

# Unit Report For RTU 1

Project: Nike 202 Chesterfield MO  
 Prepared By: Dan Dillman

01/24/2025  
 10:26AM

**Unit Parameters**

Unit Model:.....**50GECN14A2M6-3W4F0**  
 Unit Size:.....**14 (12.5 Tons)**  
 Volts-Phase-Hertz:.....**460-3-60**  
 Heating Type:.....**Electric**  
 Refrigerant:.....**R-454B**  
 Heat Control:.....**High Electric Heat**  
 Duct Cfg:.....**Vertical Supply / Vertical Return**  
 DX Options:**Two Stage Cooling, Single Circuit with Humidimizer**

**Dimensions (ft. in.) & Weight (lb.) \*\*\***

Unit Length:.....**9' 7.875"**  
 Unit Width:.....**5' 3.375"**  
 Unit Height:.....**4' 9.375"**  
**Total Operating Weight:.....1520 lb**

\*\*\* Weights and Dimensions are approximate. Weight does not include unit packaging. Approximate dimensions are provided primarily for shipping purposes. For exact dimensions and weights, refer to appropriate product data catalog.

**Lines and Filters**

Condensate Drain Line Size:.....**3/4**  
 Return Air Filter Type:.....**Throwaway**  
 Return Air Filter Quantity:.....**6**  
 Return Air Filter Size:.....**18 x 24 x 2**

**Selection includes construction throwaway filter into the base fan curve.**

**Unit Configuration**

High Electric Heat  
 Two Stage Cooling, Single Circuit with Humidimizer  
 Standard/Medium Static - EcoBlue Vane Axial Fan  
 Al/Cu - Al/Cu - Louvered Hail Guards  
 SystemVu Controller  
 ULL Enthalpy Economizer with Barometric Relief  
 Hinged Panels and Unpowered Convenience Outlet  
 Non-Fused Disconnect and Thru-The-Base Connections  
 Standard Packaging  
 Humidi-MiZer™ Adaptive Dehumidification System

**Warranty Information**

No standard warranties.  
 COMPLETE UNIT YEAR 2-5 PARTS ONLY

**NOTE: Please see Warranty Catalog 500-089 for explanation of policies and ordering methods.**

**Ordering Information**

| Part Number                        | Description                     | Quantity |
|------------------------------------|---------------------------------|----------|
| 50GECN14A2M6-3W4F0                 | Rooftop Unit                    | 1        |
| <b>Field Installed Accessories</b> |                                 |          |
| CRHUMDSN001B00                     | Outdoor or Return Air RH Sensor | 1        |

# Certified Drawing for RTU 1

Project: Nike 202 Chesterfield MO  
Prepared By: Dan Dillman

01/24/2025  
10:26AM

**NOTES:**

1. DIMENSIONS ARE IN INCHES. DIMENSIONS IN [ ] ARE IN MILLIMETERS.
2. CENTER OF GRAVITY
3. DIRECTION OF AIR FLOW

THIS DOCUMENT IS THE PROPERTY OF CARRIER CORPORATION AND IS DELIVERED UPON THE EXPRESS CONDITION THAT THE CONTENTS WILL NOT BE DISCLOSED OR USED WITHOUT CARRIER CORPORATION'S WRITTEN CONSENT.

SUBMISSION OF THESE DRAWINGS OR DOCUMENTS DOES NOT CONSTITUTE PART PERFORMANCE OR ACCEPTANCE OF CONTRACT.

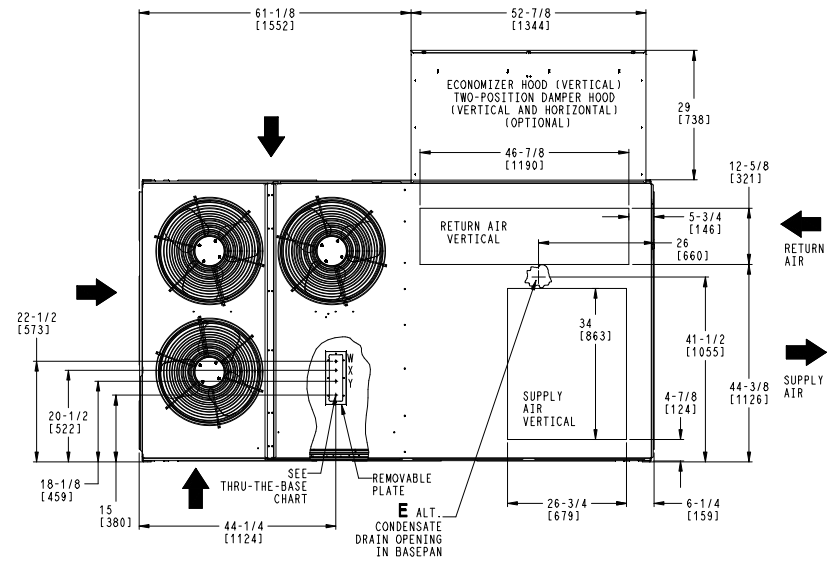
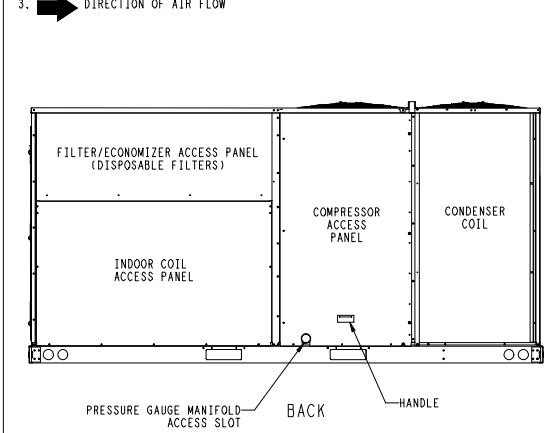

| CONNECTION SIZES |   |
|------------------|---|
| B                | 2 1/2" [64] DIA POWER SUPPLY HOLE           |
| D                | 7/8" [22] DIA FIELD CONTROL WIRING HOLE     |
| E                | 3/4"-14 NPT CONDENSATE DRAIN                |
| F                | 7/8" [22] DIA FIELD CONVENIENCE OUTLET HOLE |

| THRU-THE-BASE CHART<br>THESE HOLES REQUIRED FOR USE<br>CRBTMPWRO05A00, 006A00, 007A00 |                       |          |                         |
|---|-----------------------|----------|-------------------------|
| ACCESSORY NO.   | THREADED CONDUIT SIZE | WIRE USE | REQ'D HOLE SIZES (MAX.) |
| 005   | W 1/2"                | ACC.     | 7/8" [22.2]             |
|   | X 1/2"                | 24V      | 7/8" [22.2]             |
|   | Y 1 1/4"              | POWER    | 1 1/2" [38.1]           |
| 006   | W 1/2"                | ACC.     | 7/8" [22.2]             |
|   | X 1/2"                | 24V      | 7/8" [22.2]             |
|   | Y 1 1/2"              | POWER    | 2" [50.8]               |
| 007   | W 1/2"                | ACC.     | 7/8" [22.2]             |
|   | X 1/2"                | 24V      | 7/8" [22.2]             |
|   | Y 2"                  | POWER    | 2 1/2" [63.5]           |

FOR "THRU-THE-BASEPAN" FACTORY OPTION, FITTINGS FOR X & Y ARE PROVIDED AS SPECIFIED ON "006".

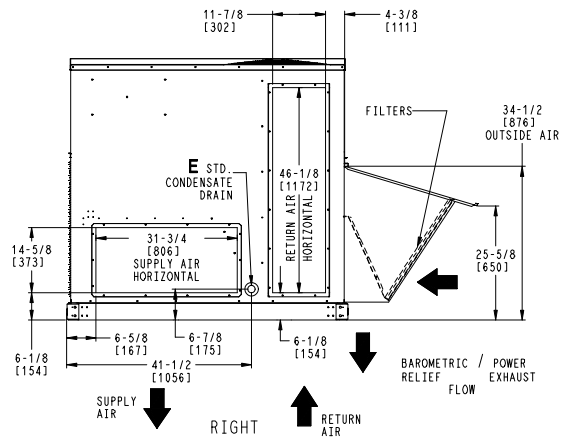
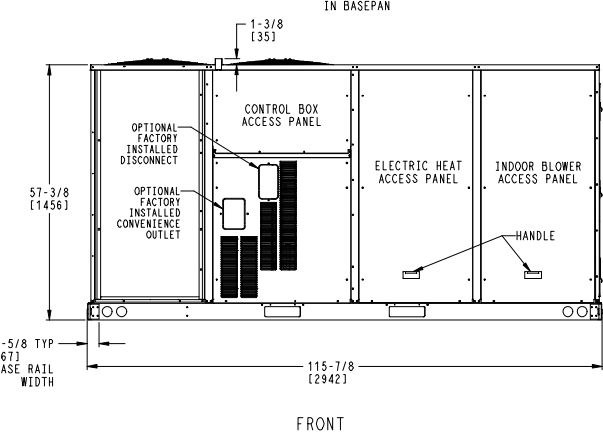
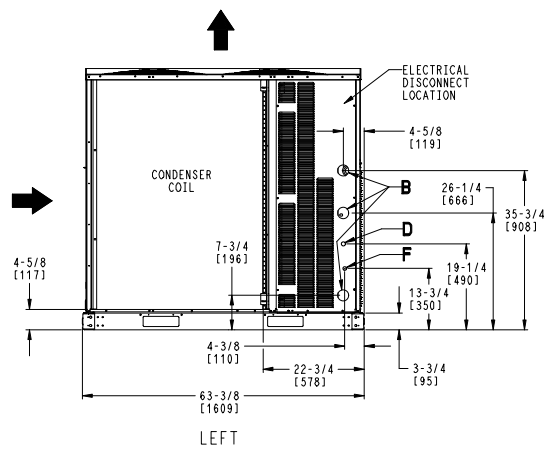

|                                     |                 |                 |                 |   |            |          |
|-------------------------------------|-----------------|-----------------|-----------------|---|------------|----------|
| ITC CLASSIFICATION<br>U.S. ECCN:NSR | SHEET<br>1 OF 2 | DATE<br>5/24/24 | SUPERCEDES<br>- | 50GE 14 SINGLE ZONE ELECTRICAL COOLING WITH ELECTRIC HEAT | 48TM009910 | REV<br>- |
|-------------------------------------|-----------------|-----------------|-----------------|---|------------|----------|

# Certified Drawing for RTU 1

Project: Nike 202 Chesterfield MO  
 Prepared By: Dan Dillman

01/24/2025  
 10:26AM

| UNIT     | STD UNIT WEIGHT |     | CORNER WEIGHT (A) |     | CORNER WEIGHT (B) |     | CORNER WEIGHT (C) |     | CORNER WEIGHT (D) |     | C.G.          |          |              |
|----------|-----------------|-----|-------------------|-----|-------------------|-----|-------------------|-----|-------------------|-----|---------------|----------|--------------|
|          | LBS.            | KG. | LBS.              | KG. | LBS.              | KG. | LBS.              | KG. | LBS.              | KG. | X             | Y        | Z            |
| 50GE-M14 | 1313            | 596 | 324               | 147 | 305               | 138 | 331               | 150 | 353               | 160 | 56 1/8 [1426] | 33 [838] | 21 1/8 [537] |

STANDARD UNIT WEIGHT IS WITHOUT ELECTRIC HEAT & WITHOUT PACKAGING.  
 FOR OPTIONS & ACCESSORIES, REFER TO THE PRODUCT DATA CATALOG.

**Carrier** THIS DOCUMENT IS THE PROPERTY OF CARRIER CORPORATION AND IS DELIVERED UPON THE EXPRESS CONDITION THAT THE CONTENTS WILL NOT BE DISCLOSED OR USED WITHOUT CARRIER CORPORATION'S WRITTEN CONSENT. SUBMISSION OF THESE DRAWINGS OR DOCUMENTS DOES NOT CONSTITUTE PART PERFORMANCE OR ACCEPTANCE OF CONTRACT.

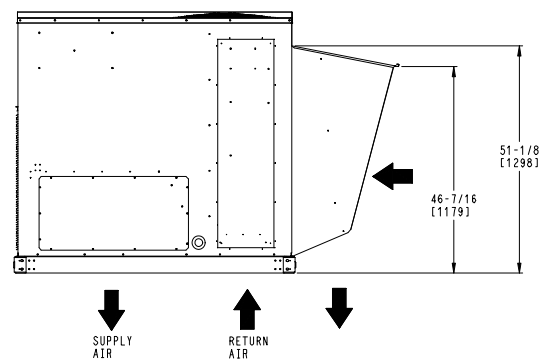
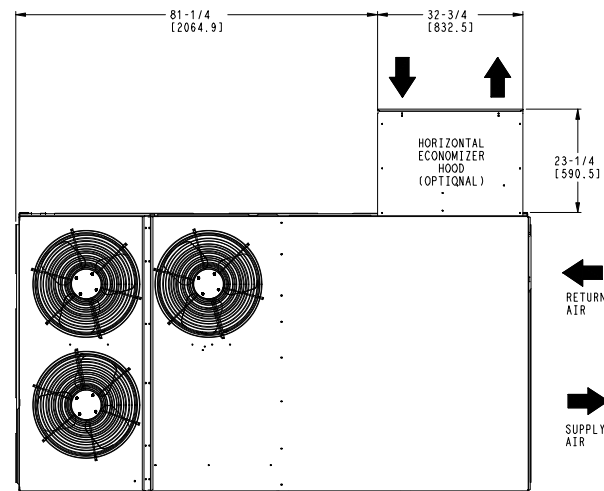
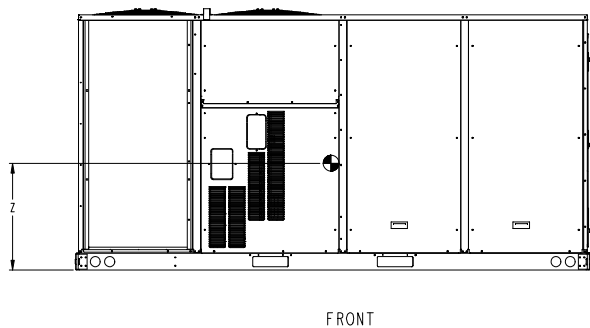
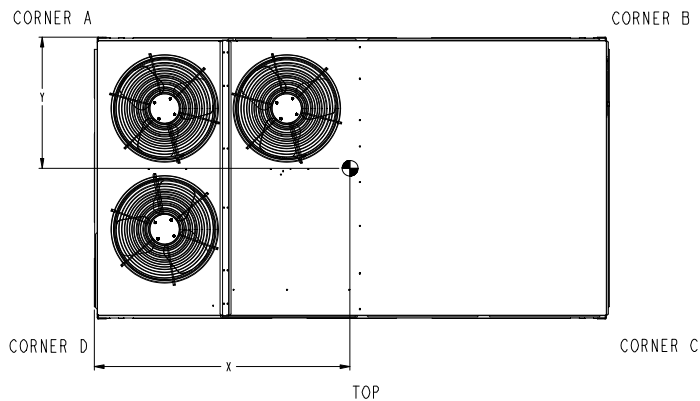

## HORIZONTAL ECONOMIZER

| ITC CLASSIFICATION | SHEET  | DATE    | SUPERCEDES | 50GE 14 SINGLE ZONE ELECTRICAL COOLING WITH ELECTRIC HEAT | 48TM009910 | REV |
|--------------------|--------|---------|------------|---|------------|-----|
| U. S. ECCN: NSR    | 2 OF 2 | 5/24/24 | -          |   |            | -   |

# Performance Summary For RTU 1

Project: Nike 202 Chesterfield MO  
 Prepared By: Dan Dillman

01/24/2025  
 10:26AM

## Part Number:50GECN14A2M6-3W4F0

Refrigerant:..... **R-454B**  
 ARI EER:..... **12.20**  
 IEER (Max Cooling at Normal Cooling Design Mode):..... **16.7**

### Base Unit Dimensions

Unit Length:..... **115.9** in  
 Unit Width:..... **63.4** in  
 Unit Height:..... **57.4** in

### Operating Weight

Base Unit Weight:..... **1313** lb  
 High Electric Heat:..... **31** lb  
 Two Stage Cooling, Single Circuit with Humidifier:..... **55** lb  
 Al/Cu - Al/Cu - Louvered Hail Guards:..... **44** lb  
 SystemVu Controller:..... **2** lb  
 ULL Enthalpy Economizer with Barometric Relief:..... **57** lb  
 Hinged Panels and Unpowered Convenience Outlet:..... **9** lb  
 Non-Fused Disconnect and Thru-The-Base Connections:..... **9** lb

Total Operating Weight:..... **1520** lb

### Unit

Unit Voltage-Phase-Hertz:..... **460-3-60**  
 Air Discharge:..... **Vertical**  
 Fan Drive Type:..... **Vane Axial**  
 Actual Airflow:..... **4800** CFM  
 Site Altitude:..... **564** ft

### Cooling Performance

Condenser Entering Air DB:..... **100.0** F  
 Evaporator Entering Air DB:..... **77.3** F  
 Evaporator Entering Air WB:..... **63.7** F  
 Evaporator Entering Air Enthalpy:..... **29.19** BTU/lb  
 Evaporator Leaving Air DB:..... **56.2** F  
 Evaporator Leaving Air WB:..... **53.9** F  
 Evaporator Leaving Air Enthalpy:..... **22.67** BTU/lb  
 Gross Cooling Capacity:..... **137.90** MBH  
 Gross Sensible Capacity:..... **107.57** MBH  
 Compressor Power Input:..... **10.43** kW  
 Coil Bypass Factor:..... **0.082**

### Part Load (SubCooling Mode)

Condenser Entering Air DB:..... **95.0** F  
 Evaporator Entering Air DB:..... **80.0** F  
 Evaporator Entering Air WB:..... **67.0** F  
 Entering Air Enthalpy:..... **31.76** BTU/lb  
 Entering Air Relative Humidity:..... **51.4** %  
 Humidi-MiZer(R) Coil Leaving Air DB:..... **63.9** F  
 Humidi-MiZer(R) Coil Leaving Air WB:..... **57.9** F  
 Humidi-MiZer(R) Coil Leaving Air Enthalpy:..... **25.20** BTU/lb  
 Leaving Air Relative Humidity:..... **70.4** %  
 Grains Per LB Removed:..... **16.7**  
 Moisture gal/hr Removed:..... **6.0**  
 Gross Sensible Heat Ratio:..... **0.588**  
 Gross Cooling Capacity:..... **138.84** MBH  
 Gross Sensible Capacity:..... **81.66** MBH  
 Compressor Power Input:..... **10.18** kW

### Dehumidification (Hot Gas Reheat Mode)

## Performance Summary For RTU 1

Project: Nike 202 Chesterfield MO  
 Prepared By: Dan Dillman

01/24/2025  
 10:26AM

|  |       |        |
|--|-------|--------|
| Condenser Entering Air DB:                 | 75.0  | F      |
| Evaporator Entering Air DB:                | 75.0  | F      |
| Evaporator Entering Air WB:                | 64.0  | F      |
| Entering Air Enthalpy:                     | 29.45 | BTU/lb |
| Entering Air Relative Humidity:            | 55.4  | %      |
| Humidi-MiZer(R) Coil Leaving Air DB:       | 71.0  | F      |
| Humidi-MiZer(R) Coil Leaving Air WB:       | 59.3  | F      |
| Humidi-MiZer(R) Coil Leaving Air Enthalpy: | 26.05 | BTU/lb |
| Leaving Air Relative Humidity:             | 50.3  | %      |
| Grains Per LB Removed:                     | 15.4  |        |
| Moisture gal/hr Removed:                   | 5.6   |        |
| Gross Sensible Heat Ratio:                 | 0.280 |        |
| Gross Cooling Capacity:                    | 71.93 | MBH    |
| Gross Sensible Capacity:                   | 20.12 | MBH    |
| Compressor Power Input:                    | 8.00  | kW     |

### Mixed Air

|                         |       |     |
|-------------------------|-------|-----|
| Outdoor Air Airflow:    | 550   | CFM |
| Outdoor Air DB:         | 100.0 | F   |
| Outdoor Air WB:         | 76.0  | F   |
| Outdoor Air Htg. Temp.: | 2.0   | F   |
| Return Air DB:          | 74.4  | F   |
| Return Air WB:          | 61.8  | F   |
| Return Air Htg. Temp.:  | 62.1  | F   |

### Heating Performance

|                            |       |     |
|----------------------------|-------|-----|
| Heating Airflow:           | 4800  | CFM |
| Entering Air Temp:         | 55.2  | F   |
| Leaving Air Temp:          | 86.0  | F   |
| Electric Heating Capacity: | 45.90 | kW  |

### Supply Fan

|   |                                     |       |
|---|-------------------------------------|-------|
| External Static Pressure:                           | 1.20                                | in wg |
| Options / Accessories Static Pressure               |                                     |       |
| Electric Heaters:                                   | 0.03                                | in wg |
| Humidi-MiZer Dehumidification System:               | 0.08                                | in wg |
| Economizer:   | 0.03                                | in wg |
| Application External Static (ESP + Unit Opts/Acc.): | 1.34                                | in wg |
| Fan RPM:  | 1633                                |       |
| Fan Power:  | 2.20                                | BHP   |
| NOTE:   | Selected IFM RPM Range: 1001 - 2200 |       |

**Selection includes construction throwaway filter into the base fan curve. This filter is not MERV Rated.**

### Electrical Data

|                                   |           |
|-----------------------------------|-----------|
| Voltage Range:                    | 414 - 506 |
| Compressor #1 RLA:                | 11.9      |
| Compressor #1 LRA:                | 103       |
| Compressor #2 RLA:                | 7.7       |
| Compressor #2 LRA:                | 69        |
| Actual Electric Heater kW:        | 45.9      |
| Electric Heater FLA:              | 60.1      |
| Indoor Fan Motor Type:            | MED       |
| Indoor Fan Motor FLA (Total):     | 3.5       |
| Power Supply MCA:                 | 65        |
| Power Supply MOCP (Fuse or HACR): | 70        |
| Disconnect Size FLA:              | 73        |
| Disconnect Size LRA:              | 185       |
| Electrical Convenience Outlet:    | None      |
| Outdoor Fan [Qty / FLA (ea)]:     | 3 / 0.8   |
| Electric Heater Part Number:      | 424A      |
| Electric Heater Number of Stages: | 2         |

**Control Panel SCCR: 5kA RMS at Rated Symmetrical Voltage**

# Performance Summary For RTU 1

Project: Nike 202 Chesterfield MO  
 Prepared By: Dan Dillman

01/24/2025  
 10:26AM

## Acoustics

Sound Power Levels, db re 10E-12 Watts

|            | Discharge | Inlet | Outdoor |
|------------|-----------|-------|---------|
| 63 Hz      | 90.3      | 84.5  | 89.3    |
| 125 Hz     | 84.1      | 78.3  | 86.0    |
| 250 Hz     | 80.1      | 73.3  | 82.9    |
| 500 Hz     | 77.3      | 69.9  | 80.7    |
| 1000 Hz    | 78.3      | 69.5  | 78.5    |
| 2000 Hz    | 74.4      | 63.4  | 73.6    |
| 4000 Hz    | 68.8      | 54.1  | 69.6    |
| 8000 Hz    | 60.5      | 47.5  | 64.5    |
| A-Weighted | 82.1      | 73.4  | 83.0    |

## Advanced Acoustics

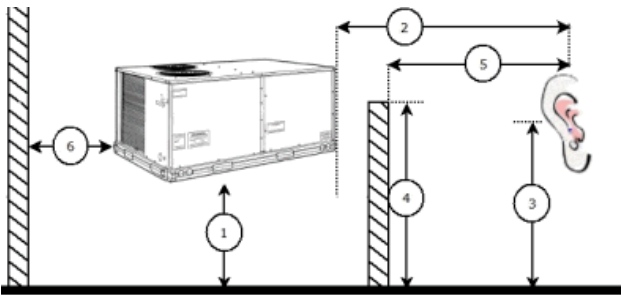

### Advanced Acoustics Parameters

- 1. Unit height above ground:..... **30.0** ft
- 2. Horizontal distance from unit to receiver:..... **50.0** ft
- 3. Receiver height above ground:..... **5.7** ft
- 4. Height of obstruction:..... **0.0** ft
- 5. Horizontal distance from obstruction to receiver:..... **0.0** ft
- 6. Horizontal distance from unit to obstruction:..... **0.0** ft

### Detailed Acoustics Information

| Octave Band Center Freq. Hz | 63   | 125  | 250  | 500  | 1k   | 2k   | 4k   | 8k   | Overall  |
|-----------------------------|------|------|------|------|------|------|------|------|----------|
| A                           | 89.3 | 86.0 | 82.9 | 80.7 | 78.5 | 73.6 | 69.6 | 64.5 | 92.2 Lw  |
| B                           | 63.1 | 69.9 | 74.3 | 77.5 | 78.5 | 74.8 | 70.6 | 63.4 | 83.2 LwA |
| C                           | 56.9 | 53.6 | 50.5 | 48.3 | 46.1 | 41.2 | 37.2 | 32.1 | 59.8 Lp  |
| D                           | 30.7 | 37.5 | 41.9 | 45.1 | 46.1 | 42.4 | 38.2 | 31.0 | 50.8 LpA |

#### Legend

- A Sound Power Levels at Unit's Acoustic Center, Lw
- B A-Weighted Sound Power Levels at Unit's Acoustic Center, LwA
- C Sound Pressure Levels at Specific Distance from Unit, Lp
- D A-Weighted Sound Pressure Levels at Specific Distance from Unit, LpA

Calculation methods used in this program are patterned after the ASHRAE Guide; other ASHRAE Publications and the AHRI Acoustical Standards. While a very significant effort has been made to insure the technical accuracy of this program, it is assumed that the user is knowledgeable in the art of system sound estimation and is aware of the tolerances involved in real world acoustical

# Performance Summary For RTU 1

Project: Nike 202 Chesterfield MO  
Prepared By: Dan Dillman

01/24/2025  
10:26AM

estimation. This program makes certain assumptions as to the dominant sound sources and sound paths which may not always be appropriate to the real system being estimated. Because of this, no assurances can be offered that this software will always generate an accurate sound prediction from user supplied input data. If in doubt about the estimation of expected sound levels in a space, an Acoustical Engineer or a person with sound prediction expertise should be consulted.

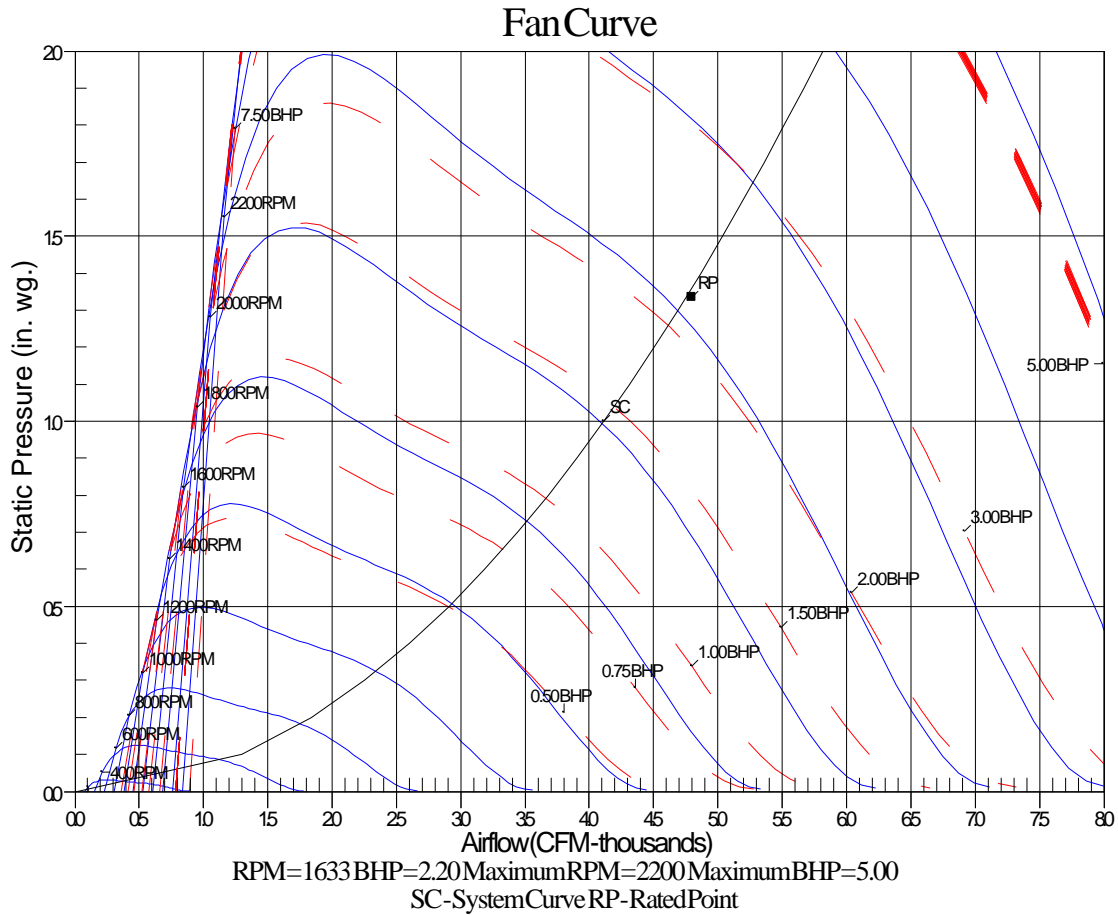

# Unit Feature Sheet for RTU 1

Project: Nike 202 Chesterfield MO  
Prepared By: Dan Dillman

01/24/2025  
10:26AM



## PURON ADVANCE™ PACKAGED ROOFTOP GAS HEATING/ELECTRIC COOLING UNITS WITH ECOBLUE TECHNOLOGY – 6, 7.5, 8.5, 10, 12.5 TONS

50GE units are single-packaged electric cooling, gas heating rooftops. All units are prewired and pre-charged with Carrier's new, low global warming potential Puron Advance™ (R-454B) refrigerant. Puron Advance represents a 75% reduction in refrigerant GWP over legacy Puron™ (R-410A) models. All units are factory tested in both heating and cooling modes and use two stage cooling capacity control



Use of the AHRI Certified™ Mark indicates a manufacturer's participation in the program. For verification of certification for individual products, go to [www.ahriindustry.org](http://www.ahriindustry.org).



### PERFORMANCE FEATURES

- Puron Advance (R-454B) refrigerant
- Two-stage cooling capacity control on all models
- IEERs up to 17.7
- New - A2L leak detection and dissipation system factory installed standard
- Leak system ensures unit and occupant safety during operation and includes an alarm relay for optional use
- Onboard recallable leak detection history for easier troubleshooting and service
- Direct Drive – EcoBlue™ Technology Indoor fan system uses Vane Axial fan design and electronically commutated motor
- New Unit Control Board with intuitive quick fan speed adjustment
- ASHRAE 90.1 and IECC code compliant
- High Efficiency 50GE RTU units exceed federal minimums and offer increased performance and energy savings
- Exclusive non-corrosive composite condensate pans in accordance with ASHRAE 62 Standard, sloping design; side or center drain
- Pre-painted exterior panels and primer-coated interior panels tested to 500 hours salt spray protection
- TXV refrigerant metering system on all models
- Fully insulated cabinet
- Standard cooling operating range up to 125°F (52°C), and down to 40°F (-4°C), except 12 size models with 0°F (-18°C) Low Ambient kits allows cooling operation down to 0°F (-18°C).
- Rated in accordance with AHRI Standards 340/360
- Designed in accordance with Underwriters' Laboratories Standard UL 60335-1 and UL 60335-2-40
- Listed by UL and CUL-Canada

### MAINTENANCE FEATURES

- Large access panels with easy grip handles
- Innovative, easy starting, no-strip screw feature on unit access panels
- Two-inch disposable return air filters
- Tool-less filter access door
- New Vane Axial evaporator-fan system has no fan belts, pulleys, blower shaft, and blower bearings with side out design.
- Unit control board facilitates simple safety circuit troubleshooting and simplified control box arrangement.

### INSTALLATION FEATURES

- Field Convertible from vertical to horizontal airflow on all models. No special kit required on 07-12 models. Supply duct kit required for 14 size model only.
- Provisions for thru-the-bottom power entry capability
- Single point gas and electric connections
- Full perimeter base rail with built-in rigging adapters and fork truck slots

### STANDARD LIMITED PARTS WARRANTY

- 5-year compressor parts
- 5-year electric heater
- 3-year SystemVu™ controller
- 1-year parts

### AVAILABLE OPTIONS:

- Patented Humidi-MiZer® adaptive dehumidification system. This option also includes Low Ambient controls
- Electric heat available as option or accessory
- Through the base connections electric available as option
- Stainless steel gas heat exchanger includes tubes, vestibule plate and collector box.
- Foil faced insulation for ease of cleaning available as an option
- HACR, disconnect. HSCCR and convenience outlet options available
- High static motor options
- Smoke detector, supply and/or return air
- Corrosion resistant options for evaporator and condenser coils
- CO2 Sensor
- Phase Monitor Protection
- 2-position damper
- Hinged access panels
- Integrated economizer system. Low and ULTRA Low Leak versions.
- Condensate overflow switch
- SystemVu Controls

## Unit Report For RTU 2,3

Project: Nike 202 Chesterfield MO  
 Prepared By: Dan Dillman

01/24/2025  
 10:26AM

### Unit Parameters

Unit Model:.....**50GECN14A2M6-3W4F0**  
 Unit Size:.....**14 (12.5 Tons)**  
 Volts-Phase-Hertz:.....**460-3-60**  
 Heating Type:.....**Electric**  
 Refrigerant:.....**R-454B**  
 Heat Control:.....**High Electric Heat**  
 Duct Cfg:.....**Vertical Supply / Vertical Return**  
 DX Options:**Two Stage Cooling, Single Circuit with Humidimizer**

### Dimensions (ft. in.) & Weight (lb.) \*\*\*

Unit Length:.....**9' 7.875"**  
 Unit Width:.....**5' 3.375"**  
 Unit Height:.....**4' 9.375"**  
**Total Operating Weight:.....1520 lb**

\*\*\* Weights and Dimensions are approximate. Weight does not include unit packaging. Approximate dimensions are provided primarily for shipping purposes. For exact dimensions and weights, refer to appropriate product data catalog.

### Lines and Filters

Condensate Drain Line Size:.....**3/4**  
 Return Air Filter Type:.....**Throwaway**  
 Return Air Filter Quantity:.....**6**  
 Return Air Filter Size:.....**18 x 24 x 2**

**Selection includes construction throwaway filter into the base fan curve.**

### Unit Configuration

High Electric Heat  
 Two Stage Cooling, Single Circuit with Humidimizer  
 Standard/Medium Static - EcoBlue Vane Axial Fan  
 Al/Cu - Al/Cu - Louvered Hail Guards  
 SystemVu Controller  
 ULL Enthalpy Economizer with Barometric Relief  
 Hinged Panels and Unpowered Convenience Outlet  
 Non-Fused Disconnect and Thru-The-Base Connections  
 Standard Packaging  
 Humidi-MiZer™ Adaptive Dehumidification System

### Warranty Information

No standard warranties.  
 COMPLETE UNIT YEAR 2-5 PARTS ONLY

**NOTE: Please see Warranty Catalog 500-089 for explanation of policies and ordering methods.**

### Ordering Information

| Part Number                        | Description                     | Quantity |
|------------------------------------|---------------------------------|----------|
| 50GECN14A2M6-3W4F0                 | Rooftop Unit                    | 1        |
| <b>Field Installed Accessories</b> |                                 |          |
| CRHUMDSN001B00                     | Outdoor or Return Air RH Sensor | 1        |

# Performance Summary For RTU 2,3

Project: Nike 202 Chesterfield MO  
Prepared By: Dan Dillman

01/24/2025  
10:26AM

## Part Number:50GECN14A2M6-3W4F0

Refrigerant:..... **R-454B**  
ARI EER:..... **12.20**  
IEER (Max Cooling at Normal Cooling Design Mode):..... **16.7**

### Base Unit Dimensions

Unit Length:..... **115.9** in  
Unit Width:..... **63.4** in  
Unit Height:..... **57.4** in

### Operating Weight

Base Unit Weight:..... **1313** lb  
High Electric Heat:..... **31** lb  
Two Stage Cooling, Single Circuit with Humidifier:..... **55** lb  
Al/Cu - Al/Cu - Louvered Hail Guards:..... **44** lb  
SystemVu Controller:..... **2** lb  
ULL Enthalpy Economizer with Barometric Relief:..... **57** lb  
Hinged Panels and Unpowered Convenience Outlet:..... **9** lb  
Non-Fused Disconnect and Thru-The-Base Connections:..... **9** lb

Total Operating Weight:..... **1520** lb

### Unit

Unit Voltage-Phase-Hertz:..... **460-3-60**  
Air Discharge:..... **Vertical**  
Fan Drive Type:..... **Vane Axial**  
Actual Airflow:..... **4000** CFM  
Site Altitude:..... **564** ft

### Cooling Performance

Condenser Entering Air DB:..... **100.0** F  
Evaporator Entering Air DB:..... **82.9** F  
Evaporator Entering Air WB:..... **67.3** F  
Evaporator Entering Air Enthalpy:..... **31.98** BTU/lb  
Evaporator Leaving Air DB:..... **57.6** F  
Evaporator Leaving Air WB:..... **55.9** F  
Evaporator Leaving Air Enthalpy:..... **23.93** BTU/lb  
Gross Cooling Capacity:..... **142.02** MBH  
Gross Sensible Capacity:..... **107.27** MBH  
Compressor Power Input:..... **10.43** kW  
Coil Bypass Factor:..... **0.050**

### Mixed Air

Outdoor Air Airflow:..... **950** CFM  
Outdoor Air DB:..... **100.0** F  
Outdoor Air WB:..... **76.0** F  
Outdoor Air Htg. Temp.:..... **2.0** F  
Return Air DB:..... **77.6** F  
Return Air WB:..... **64.2** F  
Return Air Htg. Temp.:..... **54.8** F

### Heating Performance

Heating Airflow:..... **4000** CFM  
Entering Air Temp:..... **42.3** F  
Leaving Air Temp:..... **79.3** F  
Electric Heating Capacity:..... **45.90** kW

### Supply Fan

External Static Pressure:..... **1.20** in wg  
Options / Accessories Static Pressure

## Performance Summary For RTU 2,3

Project: Nike 202 Chesterfield MO  
 Prepared By: Dan Dillman

01/24/2025  
 10:26AM

|  |  |       |
|--|--|-------|
| Electric Heaters:.....                                   | <b>0.02</b>                                | in wg |
| Humidi-MiZer Dehumidification System:.....               | <b>0.06</b>                                | in wg |
| Economizer:.....   | <b>0.02</b>                                | in wg |
| Application External Static (ESP + Unit Opts/Acc.):..... | <b>1.30</b>                                | in wg |
| Fan RPM:.....  | <b>1525</b>                                |       |
| Fan Power:.....  | <b>1.81</b>                                | BHP   |
| NOTE:.....   | <b>Selected IFM RPM Range: 1001 - 2200</b> |       |

**Selection includes construction throwaway filter into the base fan curve. This filter is not MERV Rated.**

### Electrical Data

|  |                  |
|--|------------------|
| Voltage Range:.....                    | <b>414 - 506</b> |
| Compressor #1 RLA:.....                | <b>11.9</b>      |
| Compressor #1 LRA:.....                | <b>103</b>       |
| Compressor #2 RLA:.....                | <b>7.7</b>       |
| Compressor #2 LRA:.....                | <b>69</b>        |
| Actual Electric Heater kW:.....        | <b>45.9</b>      |
| Electric Heater FLA:.....              | <b>60.1</b>      |
| Indoor Fan Motor Type:.....            | <b>MED</b>       |
| Indoor Fan Motor FLA (Total):.....     | <b>3.5</b>       |
| Power Supply MCA:.....                 | <b>65</b>        |
| Power Supply MOCP (Fuse or HACR):..... | <b>70</b>        |
| Disconnect Size FLA:.....              | <b>73</b>        |
| Disconnect Size LRA:.....              | <b>185</b>       |
| Electrical Convenience Outlet:.....    | <b>None</b>      |
| Outdoor Fan [Qty / FLA (ea)]:.....     | <b>3 / 0.8</b>   |
| Electric Heater Part Number:.....      | <b>424A</b>      |
| Electric Heater Number of Stages:..... | <b>2</b>         |

**Control Panel SCCR: 5kA RMS at Rated Symmetrical Voltage**

### Acoustics

Sound Power Levels, db re 10E-12 Watts

|            | Discharge | Inlet | Outdoor |
|------------|-----------|-------|---------|
| 63 Hz      | 91.1      | 85.0  | 89.3    |
| 125 Hz     | 84.3      | 78.7  | 86.0    |
| 250 Hz     | 79.1      | 73.5  | 82.9    |
| 500 Hz     | 75.9      | 69.0  | 80.7    |
| 1000 Hz    | 77.0      | 68.2  | 78.5    |
| 2000 Hz    | 73.0      | 62.0  | 73.6    |
| 4000 Hz    | 67.2      | 53.0  | 69.6    |
| 8000 Hz    | 59.0      | 46.9  | 64.5    |
| A-Weighted | 80.9      | 72.7  | 83.0    |

### Advanced Acoustics

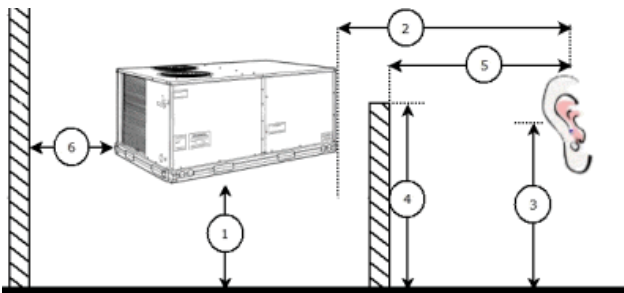

### Advanced Acoustics Parameters

## Performance Summary For RTU 2,3

Project: Nike 202 Chesterfield MO  
 Prepared By: Dan Dillman

01/24/2025  
 10:26AM

- 1. Unit height above ground:.....**30.0** ft
- 2. Horizontal distance from unit to receiver:.....**50.0** ft
- 3. Receiver height above ground:.....**5.7** ft
- 4. Height of obstruction:.....**0.0** ft
- 5. Horizontal distance from obstruction to receiver:.....**0.0** ft
- 6. Horizontal distance from unit to obstruction:.....**0.0** ft

### Detailed Acoustics Information

| Octave Band Center Freq. Hz | 63   | 125  | 250  | 500  | 1k   | 2k   | 4k   | 8k   | Overall  |
|-----------------------------|------|------|------|------|------|------|------|------|----------|
| A                           | 89.3 | 86.0 | 82.9 | 80.7 | 78.5 | 73.6 | 69.6 | 64.5 | 92.2 Lw  |
| B                           | 63.1 | 69.9 | 74.3 | 77.5 | 78.5 | 74.8 | 70.6 | 63.4 | 83.2 LwA |
| C                           | 56.9 | 53.6 | 50.5 | 48.3 | 46.1 | 41.2 | 37.2 | 32.1 | 59.8 Lp  |
| D                           | 30.7 | 37.5 | 41.9 | 45.1 | 46.1 | 42.4 | 38.2 | 31.0 | 50.8 LpA |

#### Legend

- A Sound Power Levels at Unit's Acoustic Center, Lw
- B A-Weighted Sound Power Levels at Unit's Acoustic Center, LwA
- C Sound Pressure Levels at Specific Distance from Unit, Lp
- D A-Weighted Sound Pressure Levels at Specific Distance from Unit, LpA

Calculation methods used in this program are patterned after the ASHRAE Guide; other ASHRAE Publications and the AHRI Acoustical Standards. While a very significant effort has been made to insure the technical accuracy of this program, it is assumed that the user is knowledgeable in the art of system sound estimation and is aware of the tolerances involved in real world acoustical estimation. This program makes certain assumptions as to the dominant sound sources and sound paths which may not always be appropriate to the real system being estimated. Because of this, no assurances can be offered that this software will always generate an accurate sound prediction from user supplied input data. If in doubt about the estimation of expected sound levels in a space, an Acoustical Engineer or a person with sound prediction expertise should be consulted.

# Performance Summary For RTU 2,3

Project: Nike 202 Chesterfield MO  
Prepared By: Dan Dillman

01/24/2025  
10:26AM

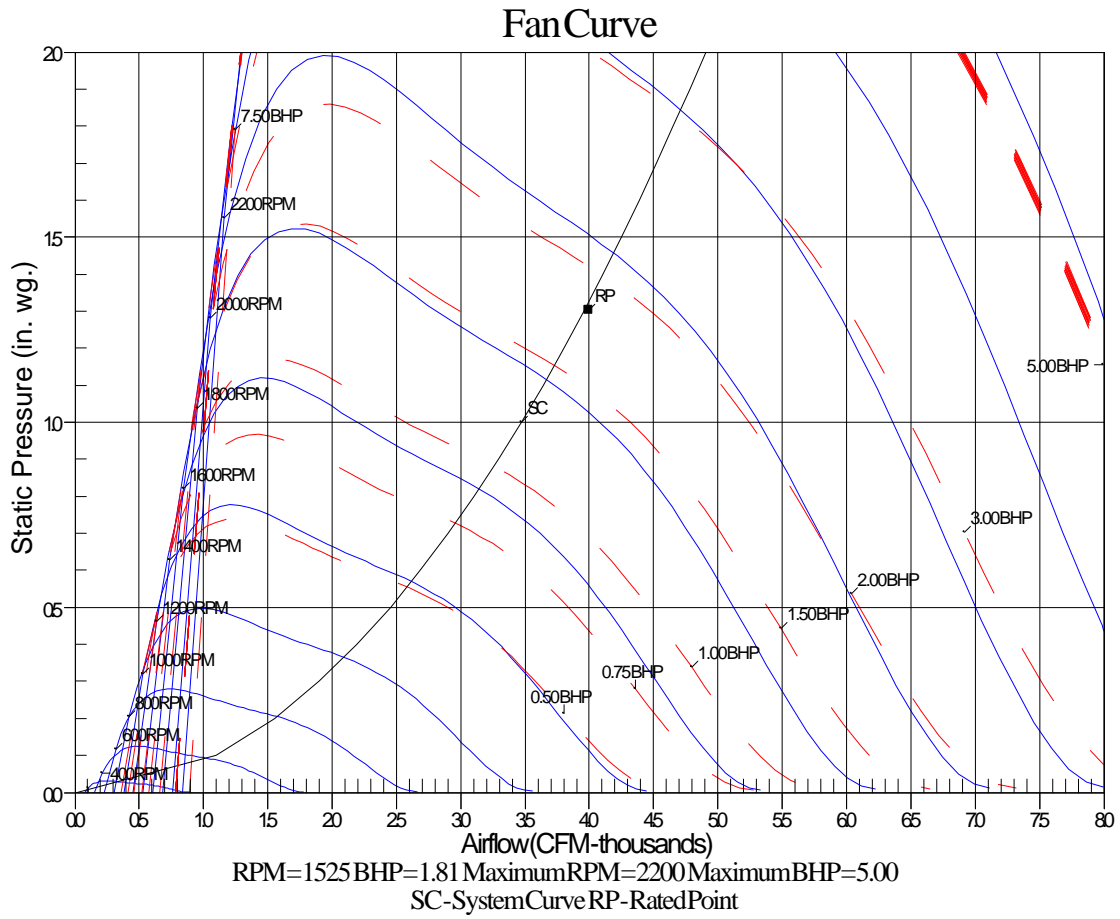

## Unit Report For RTU 4

Project: Nike 202 Chesterfield MO  
 Prepared By: Dan Dillman

01/24/2025  
 10:26AM

### Unit Parameters

Unit Model:..... **50GE-N05A2M6-3W4F0**  
 Unit Size:..... **05 (4 Tons)**  
 Volts-Phase-Hertz:..... **460-3-60**  
 Heating Type:..... **Electric**  
 Refrigerant:..... **R-454B**  
 Heat Control:..... **No Heat**  
 Duct Cfg:..... **Vertical Supply / Vertical Return**  
 DX Options: **Two Stage Cooling, Single Circuit with Humidimizer**

### Dimensions (ft. in.) & Weight (lb.) \*\*\*

Unit Length:..... **6' 2.375"**  
 Unit Width:..... **3' 10.625"**  
 Unit Height:..... **2' 9.375"**  
**Total Operating Weight:.....669 lb**

\*\*\* Weights and Dimensions are approximate. Weight does not include unit packaging. Approximate dimensions are provided primarily for shipping purposes. For exact dimensions and weights, refer to appropriate product data catalog.

### Lines and Filters

Condensate Drain Line Size:..... **3/4**  
 Return Air Filter Type:..... **Throwaway**  
 Return Air Filter Quantity:..... **2**  
 Return Air Filter Size:..... **16 x 25 x 2**

**Selection includes construction throwaway filter into the base fan curve.**

### Unit Configuration

Two Stage Cooling, Single Circuit with Humidimizer  
 Standard/Medium Static - EcoBlue Vane Axial Fan  
 Al/Cu - Al/Cu - Louvered Hail Guards  
 SystemVu Controller  
 ULL Enthalpy Economizer with Barometric Relief  
 Hinged Panels and Unpowered Convenience Outlet  
 Non-Fused Disconnect and Thru-The-Base Connections  
 Standard  
 Humidi-MiZer™ Adaptive Dehumidification System

### Warranty Information

5-Year compressor parts (STD.)  
 5-Year electric heater (STD.)  
 1-Year parts (STD.)  
**COMPLETE UNIT YEAR 2-5 PARTS ONLY**

**NOTE: Please see Warranty Catalog 500-089 for explanation of policies and ordering methods.**

### Ordering Information

| Part Number                        | Description                      | Quantity |
|------------------------------------|----------------------------------|----------|
| 50GE-N05A2M6-3W4F0                 | Rooftop Unit                     | 1        |
| <b>Field Installed Accessories</b> |                                  |          |
| CRHUMDSN001B00                     | Outdoor or Return Air RH Sensor  | 1        |
| CRHEATER337A00                     | 19.7 kW 480-3-60 Electric Heater | 1        |
| CRSINGLE037A00                     | Single Point Kit                 | 1        |

# Certified Drawing for RTU 4

Project: Nike 202 Chesterfield MO  
Prepared By: Dan Dillman

01/24/2025  
10:26AM

- NOTES:
1. DIMENSIONS ARE IN INCHES. DIMENSIONS IN [ ] ARE IN MILLIMETERS.
  2. CENTER OF GRAVITY
  3. DIRECTION OF AIR FLOW
  4. ALL VIEW DRAWN USING 3RD ANGLE

| UNIT     | J             | K            |
|----------|---------------|--------------|
| 50GE**04 | 33 3/8 [847]  | 14 7/8 [377] |
| 50GE**05 | 33 3/8 [847]  | 14 7/8 [377] |
| 50GE**06 | 41 3/8 [1051] | 18 5/8 [472] |

THIS DOCUMENT IS THE PROPERTY OF CARRIER CORPORATION AND IS DELIVERED UPON THE EXPRESS CONDITION THAT THE CONTENTS WILL NOT BE DISCLOSED OR USED WITHOUT CARRIER CORPORATION'S WRITTEN CONSENT. SUBMISSION OF THESE DRAWINGS OR DOCUMENTS DOES NOT CONSTITUTE PART PERFORMANCE OR ACCEPTANCE OF CONTRACT.

| CONNECTION SIZES |   |
|------------------|---|
| A                | 1 3/8" [35] DIA FIELD POWER SUPPLY HOLE |
| B                | 2" [51] DIA POWER SUPPLY KNOCKOUT       |
| C                | 1 3/4" [44] DIA GAUGE ACCESS PLUG       |
| D                | 7/8" [22] DIA FIELD CONTROL WIRING HOLE |
| E                | 3/4"-14 NPT CONDENSATE DRAIN            |
| G                | 2 1/2" [64] DIA POWER SUPPLY KNOCK-OUT  |

| THRU-THE-BASE CHART<br>THESE HOLES REQUIRED FOR USE<br>CRBTMPWRO08A00, 009A00 |                       |          |                         |
|---|-----------------------|----------|-------------------------|
|   | THREADED CONDUIT SIZE | WIRE USE | REQ'D HOLE SIZES (MAX.) |
| W   | 1/2"                  | 115V     | 7/8" [22.2]             |
| X   | 1/2"                  | 24V      | 7/8" [22.2]             |
| Y *   | 3/4"                  | POWER    | 1 1/8" [28.6]           |
| Z**   | (009A00) 1/2" FPT     | GAS      | 1 1/8" [28.6]           |

FOR "THRU-THE-BASEPAN" FACTORY OPTION, FITTINGS FOR ONLY X, Y, & Z ARE PROVIDED

\* SELECT EITHER 3/4" OR 1/2" FOR POWER, DEPENDING ON WIRE SIZE

\*\* (008A00) PROVIDES 3/4" FPT THRU CURB FLANGE & FITTING.

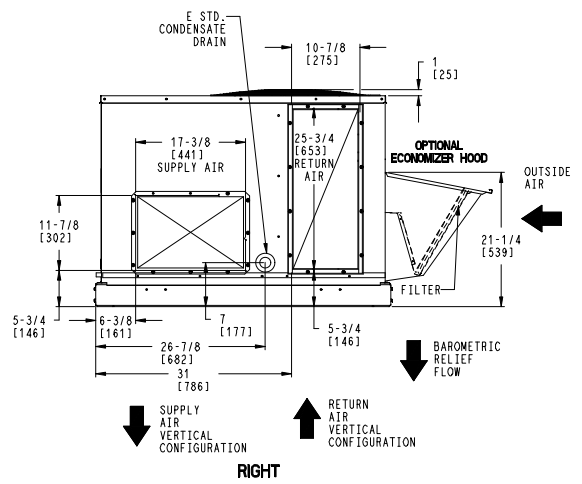
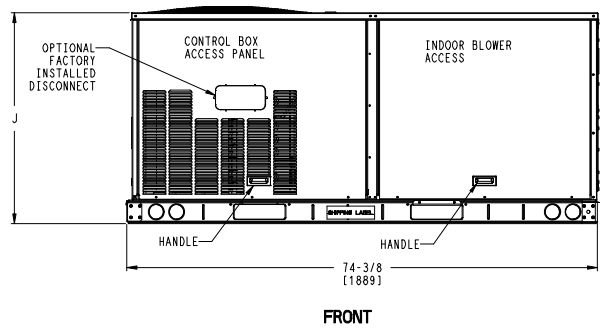
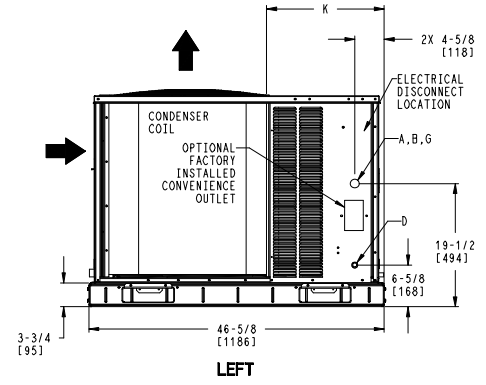
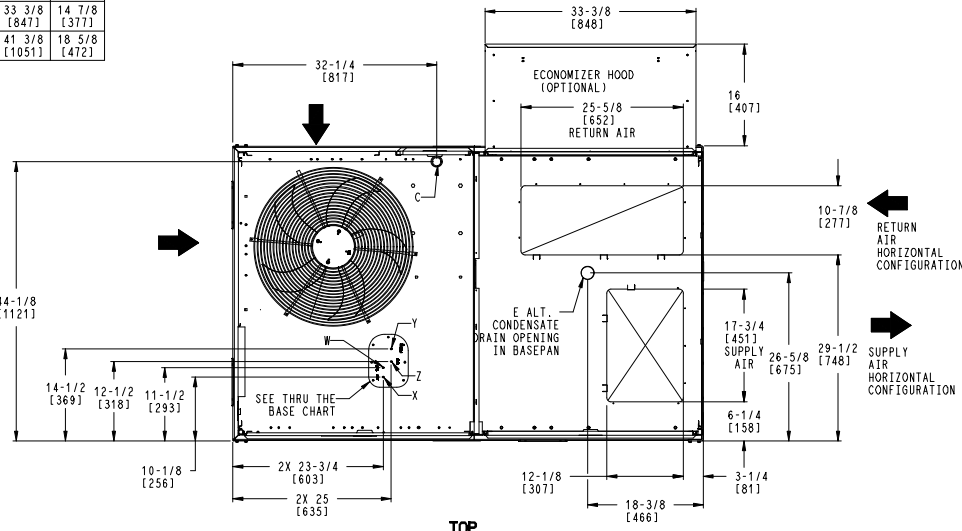

| ITC CLASSIFICATION | SHEET  | DATE    | SUPERCEDES | 50GE 04-06 SINGLE PACKAGE ELECTRICAL COOLING WITH ELECTRIC HEAT | 48TC006644 | REV |
|--------------------|--------|---------|------------|---|------------|-----|
| U.S. ECCN:NSR      | 1 OF 3 | 5/16/24 | 9/15/23    |   |            | A   |

# Certified Drawing for RTU 4

Project: Nike 202 Chesterfield MO  
 Prepared By: Dan Dillman

01/24/2025  
 10:26AM

| UNIT     | STD. UNIT WEIGHT * |     | CORNER WEIGHT (A) |     | CORNER WEIGHT (B) |     | CORNER WEIGHT (C) |     | CORNER WEIGHT (D) |     | C.G.         |              | HEIGHT       |              |
|----------|--------------------|-----|-------------------|-----|-------------------|-----|-------------------|-----|-------------------|-----|--------------|--------------|--------------|--------------|
|          | LBS.               | KG. | LBS.              | KG. | LBS.              | KG. | LBS.              | KG. | LBS.              | KG. | X            | Y            | Z            |              |
| 50GE**04 | 490                | 222 | 127               | 58  | 119               | 54  | 118               | 54  | 126               | 57  | 36           | [914]        | 23 1/4 [591] | 18 1/8 [460] |
| 50GE**05 | 510                | 231 | 140               | 64  | 128               | 58  | 116               | 53  | 127               | 58  | 35 1/2 [902] | 22 1/4 [565] | 18 3/8 [467] |              |
| 50GE**06 | 555                | 252 | 152               | 69  | 135               | 61  | 126               | 57  | 141               | 64  | 35           | [889]        | 22 1/2 [572] | 19 1/2 [495] |

\* - STANDARD UNIT WEIGHT IS WITHOUT ELECTRIC HEAT AND WITHOUT PACKAGING.  
 FOR OTHER OPTIONS AND ACCESSORIES REFER TO THE PRODUCT DATA CATALOG.

**Carrier** THIS DOCUMENT IS THE PROPERTY OF CARRIER CORPORATION AND IS DELIVERED UPON THE EXPRESS CONDITION THAT THE CONTENTS WILL NOT BE DISCLOSED OR USED WITHOUT CARRIER CORPORATION'S WRITTEN CONSENT. SUBMISSION OF THESE DRAWINGS OR DOCUMENTS DOES NOT CONSTITUTE PART PERFORMANCE OR ACCEPTANCE OF CONTRACT.

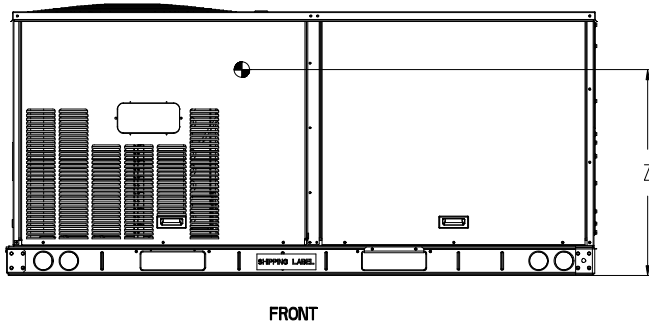
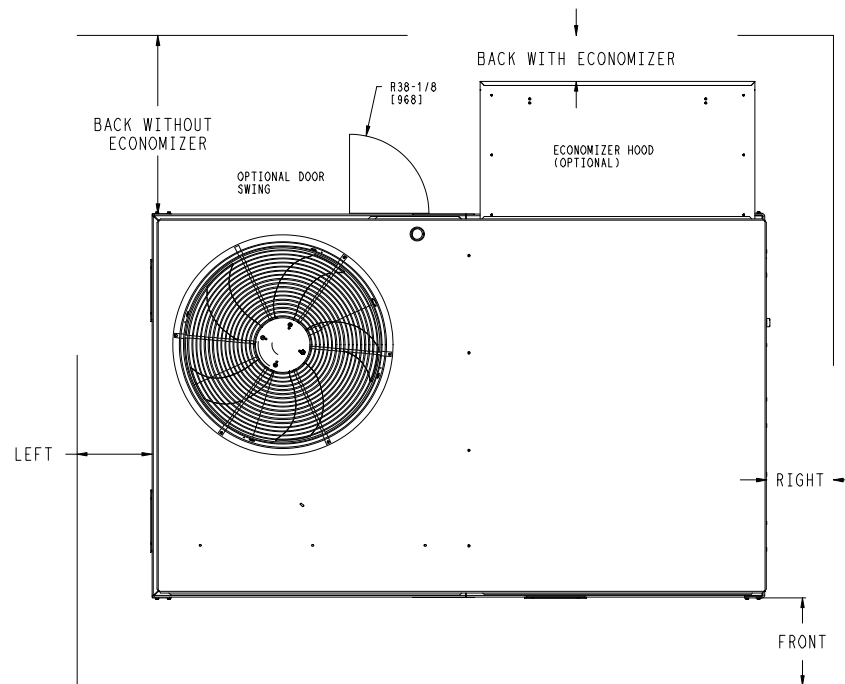
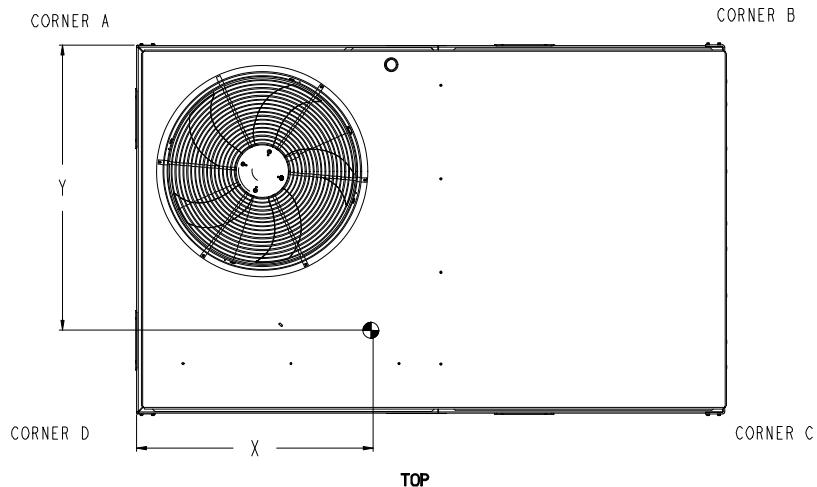

NOTE:  
 1. FOR ALL MINIMUM CLEARANCES LOCAL CODES OR JURISDICTIONS MAY PREVAIL.

| SURFACE       | CLEARANCE                       |                                    | OPERATING CLEARANCE |
|---------------|---------------------------------|------------------------------------|---------------------|
|               | SERVICE WITH CONDUCTIVE BARRIER | SERVICE WITH NONCONDUCTIVE BARRIER |                     |
| FRONT         | 48 [1219mm]                     | 36 [914mm]                         | 18 [457mm]          |
| LEFT          | 48 [1219mm]                     | 42 [1067mm]                        | 18 [457mm]          |
| BACK W/O HOOD | 48 [1219mm]                     | 42 [1067mm]                        | 18 [457mm]          |
| BACK W/HOOD   | 36 [914mm]                      | 36 [914mm]                         | 18 [457mm]          |
| RIGHT         | 36 [914mm]                      | 36 [914mm]                         | 18 [457mm]          |
| TOP           | 72 [1829mm]                     | 72 [1829mm]                        | 72 [1829mm]         |

|                                      |                 |                 |                       |   |            |          |
|--------------------------------------|-----------------|-----------------|-----------------------|---|------------|----------|
| ITC CLASSIFICATION<br>U.S. ECCN: NSR | SHEET<br>2 OF 3 | DATE<br>5/16/24 | SUPERCEDES<br>9/15/23 | 50GE 04-06 SINGLE PACKAGE ELECTRICAL COOLING WITH ELECTRIC HEAT | 48TC006644 | REV<br>A |
|--------------------------------------|-----------------|-----------------|-----------------------|---|------------|----------|

# Certified Drawing for RTU 4

Project: Nike 202 Chesterfield MO  
 Prepared By: Dan Dillman

01/24/2025  
 10:26AM

|   |   |   |
|---|---|---|
|  | THIS DOCUMENT IS THE PROPERTY OF CARRIER CORPORATION AND IS DELIVERED UPON THE EXPRESS CONDITION THAT THE CONTENTS WILL NOT BE DISCLOSED OR USED WITHOUT CARRIER CORPORATION'S WRITTEN CONSENT. | SUBMISSION OF THESE DRAWINGS OR DOCUMENTS DOES NOT CONSTITUTE PART PERFORMANCE OR ACCEPTANCE OF CONTRACT. |
|---|---|---|

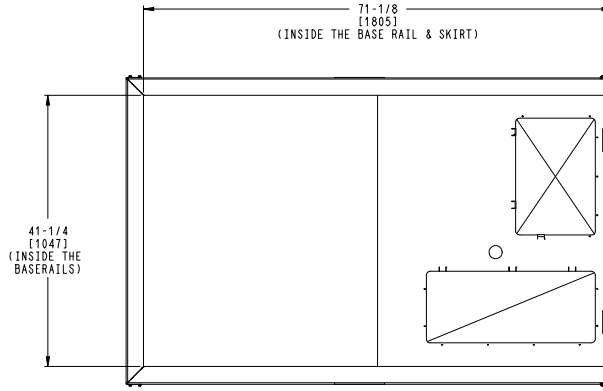
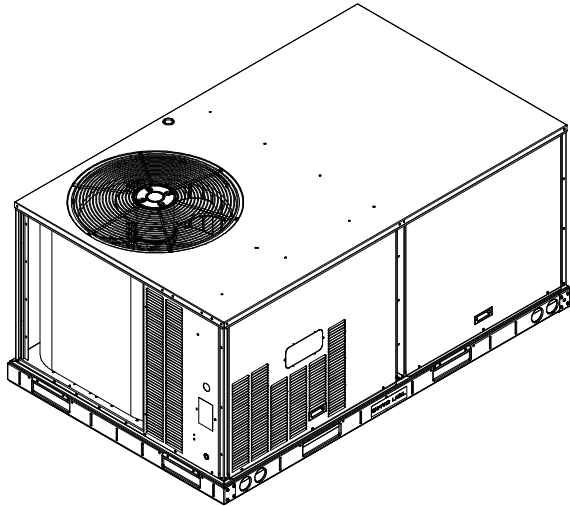

INSIDE BASERAIL DIMENSIONS  
**BOTTOM**

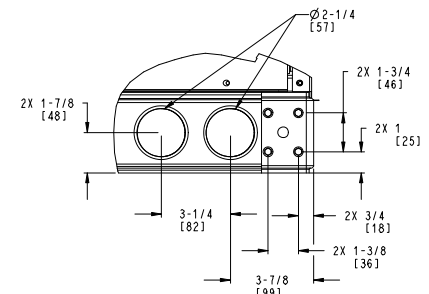

DETAIL **C**  
 TYP 4 PLCS

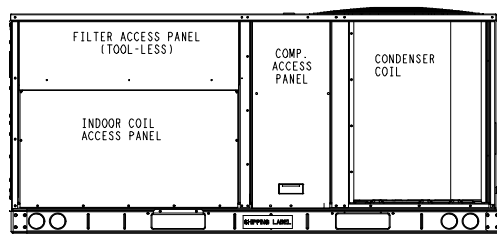

**BACK**

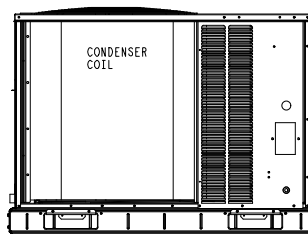

**LEFT**

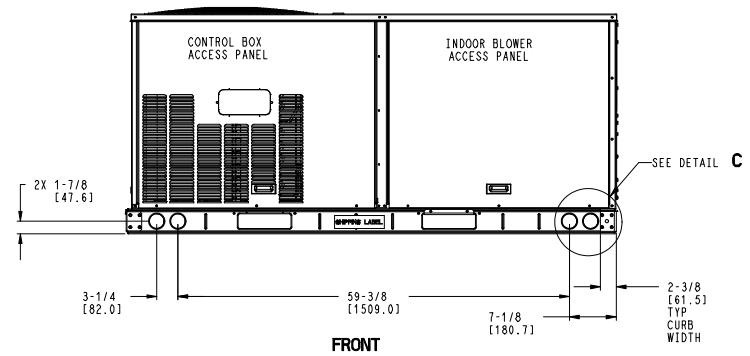

**FRONT**

|                    |        |         |            |   |            |          |
|--------------------|--------|---------|------------|---|------------|----------|
| ITC CLASSIFICATION | SHEET  | DATE    | SUPERCEDES | 50GE 04-06 SINGLE PACKAGE ELECTRICAL COOLING WITH ELECTRIC HEAT | 48TC006644 | REV<br>A |
| U.S. ECCN: NSR     | 3 OF 3 | 5/16/24 | 9/15/23    |   |            |          |

# Performance Summary For RTU 4

Project: Nike 202 Chesterfield MO  
Prepared By: Dan Dillman

01/24/2025  
10:26AM

## Part Number:50GE-N05A2M6-3W4F0

Refrigerant:..... **R-454B**  
ARI SEER:..... **17.20**  
ARI SEER2:..... **16.80**

### Base Unit Dimensions

Unit Length:..... **74.4** in  
Unit Width:..... **46.6** in  
Unit Height:..... **33.4** in

### Operating Weight

Base Unit Weight:..... **555** lb  
Two Stage Cooling, Single Circuit with Humidimizer:..... **24** lb  
Al/Cu - Al/Cu - Louvered Hail Guards:..... **13** lb  
SystemVu Controller:..... **2** lb  
ULL Enthalpy Economizer with Barometric Relief:..... **37** lb  
Hinged Panels and Unpowered Convenience Outlet:..... **9** lb  
Non-Fused Disconnect and Thru-The-Base Connections:..... **9** lb

### Accessories

19.7 kW 480-3-60 Electric Heater:..... **10** lb  
Single Point Kit:..... **10** lb

Total Operating Weight:..... **669** lb

### Unit

Unit Voltage-Phase-Hertz:..... **460-3-60**  
Air Discharge:..... **Vertical**  
Fan Drive Type:..... **Vane Axial**  
Actual Airflow:..... **1600** CFM  
Site Altitude:..... **564** ft

### Cooling Performance

Condenser Entering Air DB:..... **100.0** F  
Evaporator Entering Air DB:..... **81.7** F  
Evaporator Entering Air WB:..... **66.6** F  
Evaporator Entering Air Enthalpy:..... **31.39** BTU/lb  
Evaporator Leaving Air DB:..... **57.8** F  
Evaporator Leaving Air WB:..... **56.5** F  
Evaporator Leaving Air Enthalpy:..... **24.31** BTU/lb  
Gross Cooling Capacity:..... **49.91** MBH  
Gross Sensible Capacity:..... **40.49** MBH  
Compressor Power Input:..... **3.65** kW  
Coil Bypass Factor:..... **0.060**

### Part Load (SubCooling Mode)

Condenser Entering Air DB:..... **95.0** F  
Evaporator Entering Air DB:..... **80.0** F  
Evaporator Entering Air WB:..... **67.0** F  
Entering Air Enthalpy:..... **31.76** BTU/lb  
Entering Air Relative Humidity:..... **51.4** %  
Humidi-MiZer(R) Coil Leaving Air DB:..... **67.8** F  
Humidi-MiZer(R) Coil Leaving Air WB:..... **59.2** F  
Humidi-MiZer(R) Coil Leaving Air Enthalpy:..... **26.01** BTU/lb  
Leaving Air Relative Humidity:..... **60.9** %  
Grains Per LB Removed:..... **17.4**  
Moisture gal/hr Removed:..... **2.1**  
Gross Sensible Heat Ratio:..... **0.510**  
Gross Cooling Capacity:..... **40.62** MBH  
Gross Sensible Capacity:..... **20.73** MBH  
Compressor Power Input:..... **3.95** kW

# Performance Summary For RTU 4

Project: Nike 202 Chesterfield MO  
Prepared By: Dan Dillman

01/24/2025  
10:26AM

## Dehumidification (Hot Gas Reheat Mode)

|  |       |        |
|--|-------|--------|
| Condenser Entering Air DB:                 | 75.0  | F      |
| Evaporator Entering Air DB:                | 75.0  | F      |
| Evaporator Entering Air WB:                | 64.0  | F      |
| Entering Air Enthalpy:                     | 29.45 | BTU/lb |
| Entering Air Relative Humidity:            | 55.4  | %      |
| Humidi-MiZer(R) Coil Leaving Air DB:       | 73.5  | F      |
| Humidi-MiZer(R) Coil Leaving Air WB:       | 60.3  | F      |
| Humidi-MiZer(R) Coil Leaving Air Enthalpy: | 26.70 | BTU/lb |
| Leaving Air Relative Humidity:             | 46.4  | %      |
| Grains Per LB Removed:                     | 15.1  |        |
| Moisture gal/hr Removed:                   | 1.8   |        |
| Gross Sensible Heat Ratio:                 | 0.127 |        |
| Gross Cooling Capacity:                    | 19.40 | MBH    |
| Gross Sensible Capacity:                   | 2.46  | MBH    |
| Compressor Power Input:                    | 3.40  | kW     |

## Mixed Air

|                         |       |     |
|-------------------------|-------|-----|
| Outdoor Air Airflow:    | 315   | CFM |
| Outdoor Air DB:         | 100.0 | F   |
| Outdoor Air WB:         | 76.0  | F   |
| Outdoor Air Htg. Temp.: | 2.0   | F   |
| Return Air DB:          | 77.2  | F   |
| Return Air WB:          | 63.9  | F   |
| Return Air Htg. Temp.:  | 57.3  | F   |

## Heating Performance

|                            |       |     |
|----------------------------|-------|-----|
| Heating Airflow:           | 1600  | CFM |
| Entering Air Temp:         | 46.4  | F   |
| Leaving Air Temp:          | 86.1  | F   |
| Electric Heating Capacity: | 19.70 | kW  |

## Supply Fan

|   |                                     |       |
|---|-------------------------------------|-------|
| External Static Pressure:                           | 0.80                                | in wg |
| Options / Accessories Static Pressure               |                                     |       |
| Electric Heaters:                                   | 0.18                                | in wg |
| Humidi-MiZer Dehumidification System:               | 0.13                                | in wg |
| Economizer:   | 0.07                                | in wg |
| Application External Static (ESP + Unit Opts/Acc.): | 1.19                                | in wg |
| Fan RPM:  | 2010                                |       |
| Fan Power:  | 0.86                                | BHP   |
| NOTE:   | Selected IFM RPM Range: 1120 - 2170 |       |

Selection includes construction throwaway filter into the base fan curve. This filter is not MERV Rated.

## Electrical Data

|                                   |           |
|-----------------------------------|-----------|
| Voltage Range:                    | 414 - 506 |
| Compressor #1 RLA:                | 8.1       |
| Compressor #1 LRA:                | 62        |
| Actual Electric Heater kW:        | 19.7      |
| Electric Heater FLA:              | 25.9      |
| Indoor Fan Motor Type:            | MED       |
| Indoor Fan Motor FLA (Total):     | 1.7       |
| Power Supply MCA:                 | 35        |
| Power Supply MOCP (Fuse or HACR): | 35        |
| Disconnect Size FLA:              | 32        |
| Disconnect Size LRA:              | 66        |
| Electrical Convenience Outlet:    | None      |
| Outdoor Fan [Qty / FLA (ea)]:     | 1 / 1.4   |
| Electric Heater Part Number:      | 337A      |
| Electric Heater Number of Stages: | 2         |

Control Panel SCCR: 5kA RMS at Rated Symmetrical Voltage

# Performance Summary For RTU 4

Project: Nike 202 Chesterfield MO  
 Prepared By: Dan Dillman

01/24/2025  
 10:26AM

## Acoustics

Sound Power Levels, db re 10E-12 Watts

|            | Discharge | Inlet | Outdoor |
|------------|-----------|-------|---------|
| 63 Hz      | 94.1      | 89.4  | 85.6    |
| 125 Hz     | 85.2      | 80.2  | 84.7    |
| 250 Hz     | 79.0      | 73.0  | 80.5    |
| 500 Hz     | 73.4      | 66.4  | 76.0    |
| 1000 Hz    | 70.2      | 68.2  | 72.4    |
| 2000 Hz    | 67.9      | 59.9  | 68.0    |
| 4000 Hz    | 63.8      | 53.2  | 62.8    |
| 8000 Hz    | 60.3      | 47.1  | 59.3    |
| A-Weighted | 77.6      | 72.5  | 79.0    |

## Advanced Acoustics

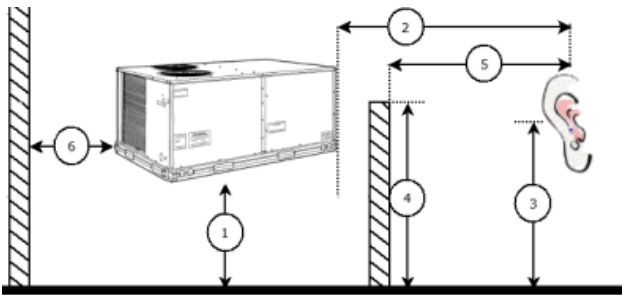

### Advanced Acoustics Parameters

- 1. Unit height above ground:..... **30.0** ft
- 2. Horizontal distance from unit to receiver:..... **50.0** ft
- 3. Receiver height above ground:..... **5.7** ft
- 4. Height of obstruction:..... **0.0** ft
- 5. Horizontal distance from obstruction to receiver:..... **0.0** ft
- 6. Horizontal distance from unit to obstruction:..... **0.0** ft

### Detailed Acoustics Information

| Octave Band Center Freq. Hz | 63   | 125  | 250  | 500  | 1k   | 2k   | 4k   | 8k   | Overall  |
|-----------------------------|------|------|------|------|------|------|------|------|----------|
| A                           | 85.6 | 84.7 | 80.5 | 76.0 | 72.4 | 68.0 | 62.8 | 59.3 | 89.2 Lw  |
| B                           | 59.4 | 68.6 | 71.9 | 72.8 | 72.4 | 69.2 | 63.8 | 58.2 | 78.5 LwA |
| C                           | 53.2 | 52.3 | 48.1 | 43.6 | 40.0 | 35.6 | 30.4 | 26.9 | 56.8 Lp  |
| D                           | 27.0 | 36.2 | 39.5 | 40.4 | 40.0 | 36.8 | 31.4 | 25.8 | 46.1 LpA |

### Legend

- A Sound Power Levels at Unit's Acoustic Center, Lw
- B A-Weighted Sound Power Levels at Unit's Acoustic Center, LwA
- C Sound Pressure Levels at Specific Distance from Unit, Lp
- D A-Weighted Sound Pressure Levels at Specific Distance from Unit, LpA

Calculation methods used in this program are patterned after the ASHRAE Guide; other ASHRAE Publications and the AHRI Acoustical Standards. While a very significant effort has been made to insure the technical accuracy of this program, it is assumed that the user is knowledgeable in the art of system sound estimation and is aware of the tolerances involved in real world acoustical

# Performance Summary For RTU 4

Project: Nike 202 Chesterfield MO  
Prepared By: Dan Dillman

01/24/2025  
10:26AM

estimation. This program makes certain assumptions as to the dominant sound sources and sound paths which may not always be appropriate to the real system being estimated. Because of this, no assurances can be offered that this software will always generate an accurate sound prediction from user supplied input data. If in doubt about the estimation of expected sound levels in a space, an Acoustical Engineer or a person with sound prediction expertise should be consulted.

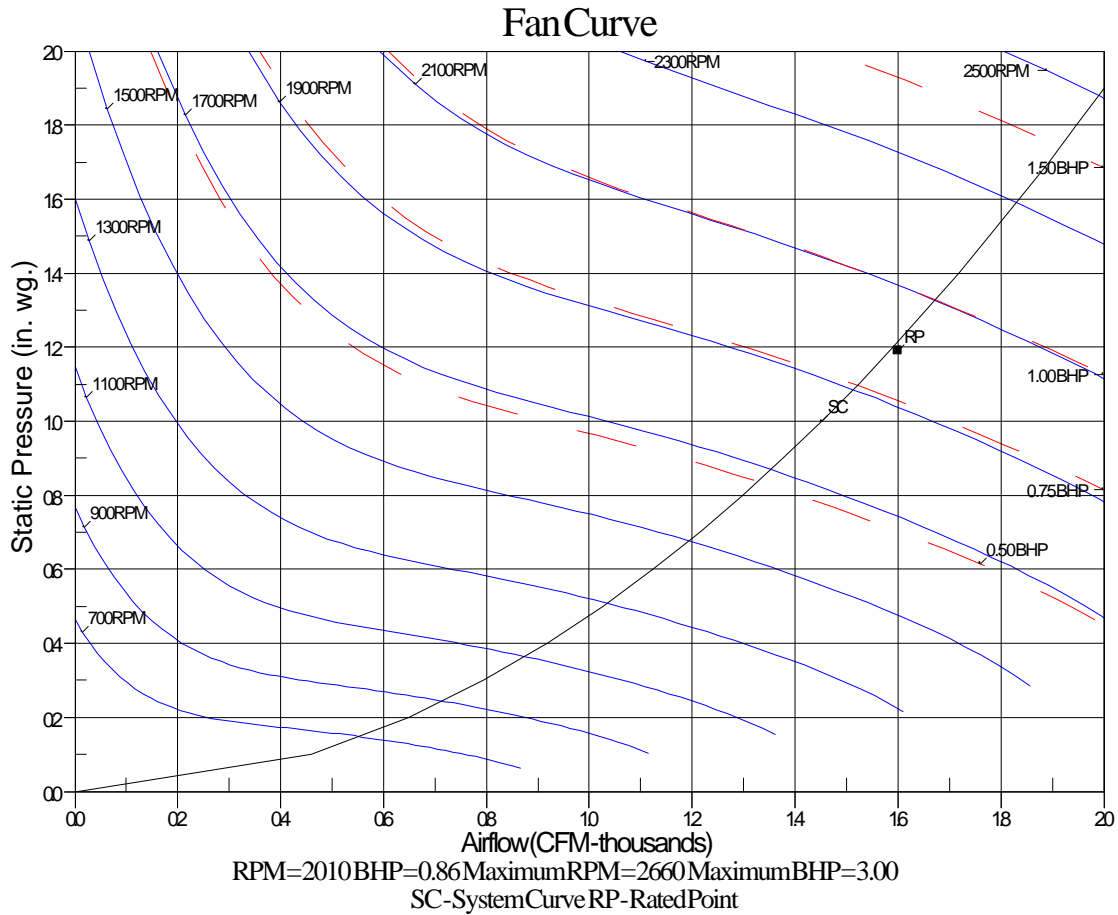

# Unit Feature Sheet for RTU 4

Project: Nike 202 Chesterfield MO  
Prepared By: Dan Dillman

01/24/2025  
10:26AM



## WeatherMaster®

### PURON ADVANCE™ PACKAGED ROOFTOP GAS HEATING/ELECTRIC COOLING UNITS 3, 4, 5 TONS – 16.8 SEER2

50GE units are single-packaged electric cooling, gas heating rooftops. All units are prewired and pre-charged with Carrier's new, low global warming potential Puron Advance™ (R-454B) refrigerant. Puron Advance represents a 75% reduction in refrigerant GWP over legacy Puron™ (R-410A) models. All units are factory tested in both heating and cooling modes. 3–5-ton models use single stage cooling capacity control. 6-ton model uses two stage cooling capacity control.



Use of the AHRI Certified TM Mark indicates a manufacturer's participation in the program. For verification of certification for individual products, go to [www.ahriindustry.org](http://www.ahriindustry.org).

Puron  
ADVANCE™

#### PERFORMANCE FEATURES

- Puron Advance (R-454B) refrigerant
- Two stage cooling capacity
- SEER2s up to 16.8
- New - A2L leak detection and dissipation system factory installed standard
- Leak system ensures unit and occupant safety during operation and includes an alarm relay for optional use
- Onboard recallable leak detection history for easier troubleshooting and service
- Direct Drive – EcoBlue™ Technology Indoor fan system uses Vane Axial fan design and electronically commutated motor
- New Unit Control Board with intuitive quick fan speed adjustment
- Sound levels as low as 76 dB
- Exclusive non-corrosive composite condensate pans in accordance with ASHRAE 62 Standard, sloping design; side or center drain
- Pre-painted exterior panels and primer-coated interior panels tested to 500 hours salt spray protection
- TXV refrigerant metering systems
- Fully insulated cabinet
- Standard cooling operating range up to 125°F (46°C), and down to 40°F (4°C). Low Ambient allows cooling operation down to -20°F (-29°C).
- Rated in accordance with AHRI Standards 210/240
- Designed in accordance with Underwriters' Laboratories Standard UL 60335-1 and UL 60335-2-40
- Listed by UL and CUL-Canada

#### MAINTENANCE FEATURES

- Large access panels with easy grip handles
- Innovative, easy starting, no-strip screw feature on unit access panels
- Two-inch disposable return air filters
- Tool-less filter access door
- New central terminal board facilitating simple safety circuit troubleshooting and simplified control box arrangement

#### INSTALLATION FEATURES

- Field Convertible from vertical to horizontal airflow on all models. No special kit required.
- Provisions for thru-the-bottom power entry capability
- Single point electric connections
- Full perimeter base rail with built-in rigging adapters and fork truck slots
- Two stage cooling thermostats required to provide great energy and comfort solutions

#### STANDARD LIMITED PARTS WARRANTY

- 5-year compressor parts
- 5-year electric heater
- 3-year SystemVu™ controller
- 1-year parts

#### AVAILABLE OPTIONS:

- Patented Humidi-MiZer® adaptive dehumidification system. This option also includes Low Ambient controls
- Through the base connections for electric available as option
- Disconnect, HACR and convenience outlet options
- Multi static indoor fan motor options
- Smoke detector, supply and/or return air
- Corrosion resistant options for evaporator and condenser coils
- CO2 Sensor
- Phase Monitor Protection
- 4" MERV-13 Filters
- Low ambient operation controls
- Factory or field installed electric heat
- Foil faced insulation
- 2-position damper (field installed only)
- Hinged access panels
- Integrated economizer system. Low and ULTRA Low Leak versions.
- Condensate overflow switch
- SystemVu Controls

## Unit Report For RTU 5

Project: Nike 202 Chesterfield MO  
 Prepared By: Dan Dillman

01/24/2025  
 10:26AM

### Unit Parameters

Unit Model:..... **50GE-N06A2M6-3W4F0**  
 Unit Size:..... **06 (5 Tons)**  
 Volts-Phase-Hertz:..... **460-3-60**  
 Heating Type:..... **Electric**  
 Refrigerant:..... **R-454B**  
 Heat Control:..... **No Heat**  
 Duct Cfg:..... **Vertical Supply / Vertical Return**  
 DX Options: **Two Stage Cooling, Single Circuit with Humidimizer**

### Dimensions (ft. in.) & Weight (lb.) \*\*\*

Unit Length:..... **6' 2.375"**  
 Unit Width:..... **3' 10.625"**  
 Unit Height:..... **3' 5.375"**  
**Total Operating Weight:.....717 lb**

\*\*\* Weights and Dimensions are approximate. Weight does not include unit packaging. Approximate dimensions are provided primarily for shipping purposes. For exact dimensions and weights, refer to appropriate product data catalog.

### Lines and Filters

Condensate Drain Line Size:..... **3/4**  
 Return Air Filter Type:..... **Throwaway**  
 Return Air Filter Quantity:..... **4**  
 Return Air Filter Size:..... **16 x 16 x 2**

**Selection includes construction throwaway filter into the base fan curve.**

### Unit Configuration

Two Stage Cooling, Single Circuit with Humidimizer  
 Standard/Medium Static - EcoBlue Vane Axial Fan  
 Al/Cu - Al/Cu - Louvered Hail Guards  
 SystemVu Controller  
 ULL Enthalpy Economizer with Barometric Relief  
 Hinged Panels and Unpowered Convenience Outlet  
 Non-Fused Disconnect and Thru-The-Base Connections  
 Standard  
 Humidi-MiZer™ Adaptive Dehumidification System

### Warranty Information

5-Year compressor parts (STD.)  
 5-Year electric heater (STD.)  
 1-Year parts (STD.)  
**COMPLETE UNIT YEAR 2-5 PARTS ONLY**

**NOTE: Please see Warranty Catalog 500-089 for explanation of policies and ordering methods.**

### Ordering Information

| Part Number                        | Description                     | Quantity |
|------------------------------------|---------------------------------|----------|
| 50GE-N06A2M6-3W4F0                 | Rooftop Unit                    | 1        |
| <b>Field Installed Accessories</b> |                                 |          |
| CRHUMDSN001B00                     | Outdoor or Return Air RH Sensor | 1        |
| CRHEATER336A00                     | Electric Heater                 | 1        |

# Certified Drawing for RTU 5

Project: Nike 202 Chesterfield MO  
Prepared By: Dan Dillman

01/24/2025  
10:26AM

- NOTES:
1. DIMENSIONS ARE IN INCHES. DIMENSIONS IN [ ] ARE IN MILLIMETERS.
  2. CENTER OF GRAVITY
  3. DIRECTION OF AIR FLOW
  4. ALL VIEW DRAWN USING 3RD ANGLE

| UNIT     | J             | K            |
|----------|---------------|--------------|
| 50GE**04 | 33 3/8 [847]  | 14 7/8 [377] |
| 50GE**05 | 33 3/8 [847]  | 14 7/8 [377] |
| 50GE**06 | 41 3/8 [1051] | 18 5/8 [472] |

THIS DOCUMENT IS THE PROPERTY OF CARRIER CORPORATION AND IS DELIVERED UPON THE EXPRESS CONDITION THAT THE CONTENTS WILL NOT BE DISCLOSED OR USED WITHOUT CARRIER CORPORATION'S WRITTEN CONSENT. SUBMISSION OF THESE DRAWINGS OR DOCUMENTS DOES NOT CONSTITUTE PART PERFORMANCE OR ACCEPTANCE OF CONTRACT.

| CONNECTION SIZES |   |
|------------------|---|
| A                | 1 3/8" [35] DIA FIELD POWER SUPPLY HOLE |
| B                | 2" [51] DIA POWER SUPPLY KNOCKOUT       |
| C                | 1 3/4" [44] DIA GAUGE ACCESS PLUG       |
| D                | 7/8" [22] DIA FIELD CONTROL WIRING HOLE |
| E                | 3/4"-14 NPT CONDENSATE DRAIN            |
| G                | 2 1/2" [64] DIA POWER SUPPLY KNOCK-OUT  |

| THRU-THE-BASE CHART<br>THESE HOLES REQUIRED FOR USE<br>CRBTMPW008A00, 009A00 |                       |          |                         |
|--|-----------------------|----------|-------------------------|
|  | THREADED CONDUIT SIZE | WIRE USE | REQ'D HOLE SIZES (MAX.) |
| W  | 1/2"                  | 115V     | 7/8" [22.2]             |
| X  | 1/2"                  | 24V      | 7/8" [22.2]             |
| Y *  | 3/4"                  | POWER    | 1 1/8" [28.6]           |
| Z**  | (009A00) 1/2" FPT     | GAS      | 1 1/8" [28.6]           |

FOR "THRU-THE-BASEPAN" FACTORY OPTION, FITTINGS FOR ONLY X, Y, & Z ARE PROVIDED

\* SELECT EITHER 3/4" OR 1/2" FOR POWER, DEPENDING ON WIRE SIZE

\*\* (008A00) PROVIDES 3/4" FPT THRU CURB FLANGE & FITTING.

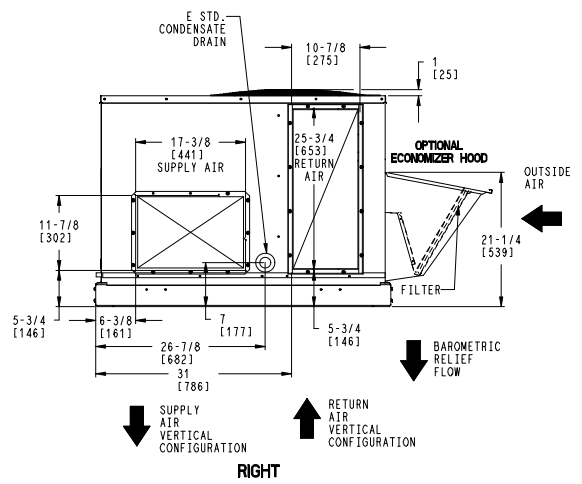
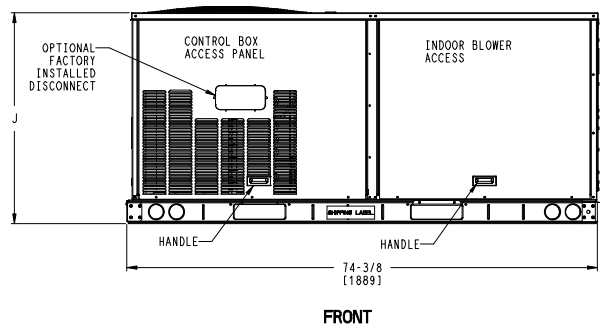
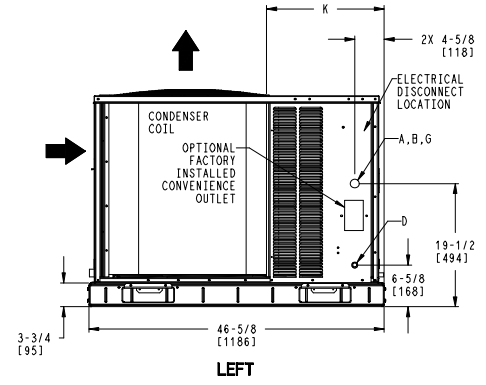
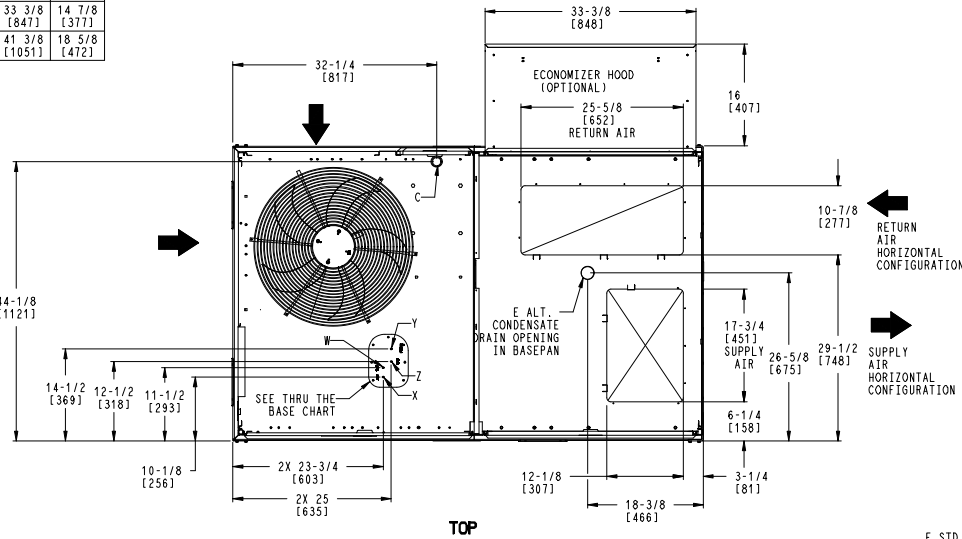

| ITC CLASSIFICATION | SHEET  | DATE    | SUPERCEDES | 50GE 04-06 SINGLE PACKAGE ELECTRICAL COOLING WITH ELECTRIC HEAT | 48TC006644 | REV |
|--------------------|--------|---------|------------|---|------------|-----|
| U.S. ECCN:NSR      | 1 OF 3 | 5/16/24 | 9/15/23    |   |            | A   |

# Certified Drawing for RTU 5

Project: Nike 202 Chesterfield MO  
Prepared By: Dan Dillman

01/24/2025  
10:26AM

| UNIT     | STD. UNIT WEIGHT * |     | CORNER WEIGHT (A) |     | CORNER WEIGHT (B) |     | CORNER WEIGHT (C) |     | CORNER WEIGHT (D) |     | C.G.         |              | HEIGHT       |              |
|----------|--------------------|-----|-------------------|-----|-------------------|-----|-------------------|-----|-------------------|-----|--------------|--------------|--------------|--------------|
|          | LBS.               | KG. | LBS.              | KG. | LBS.              | KG. | LBS.              | KG. | LBS.              | KG. | X            | Y            | Z            |              |
| 50GE**04 | 490                | 222 | 127               | 58  | 119               | 54  | 118               | 54  | 126               | 57  | 36           | [914]        | 23 1/4 [591] | 18 1/8 [460] |
| 50GE**05 | 510                | 231 | 140               | 64  | 128               | 58  | 116               | 53  | 127               | 58  | 35 1/2 [902] | 22 1/4 [565] | 18 3/8 [467] |              |
| 50GE**06 | 555                | 252 | 152               | 69  | 135               | 61  | 126               | 57  | 141               | 64  | 35           | [889]        | 22 1/2 [572] | 19 1/2 [495] |

\* - STANDARD UNIT WEIGHT IS WITHOUT ELECTRIC HEAT AND WITHOUT PACKAGING.  
FOR OTHER OPTIONS AND ACCESSORIES REFER TO THE PRODUCT DATA CATALOG.

THIS DOCUMENT IS THE PROPERTY OF CARRIER CORPORATION AND IS DELIVERED UPON THE EXPRESS CONDITION THAT THE CONTENTS WILL NOT BE DISCLOSED OR USED WITHOUT CARRIER CORPORATION'S WRITTEN CONSENT.

SUBMISSION OF THESE DRAWINGS OR DOCUMENTS DOES NOT CONSTITUTE PART PERFORMANCE OR ACCEPTANCE OF CONTRACT.

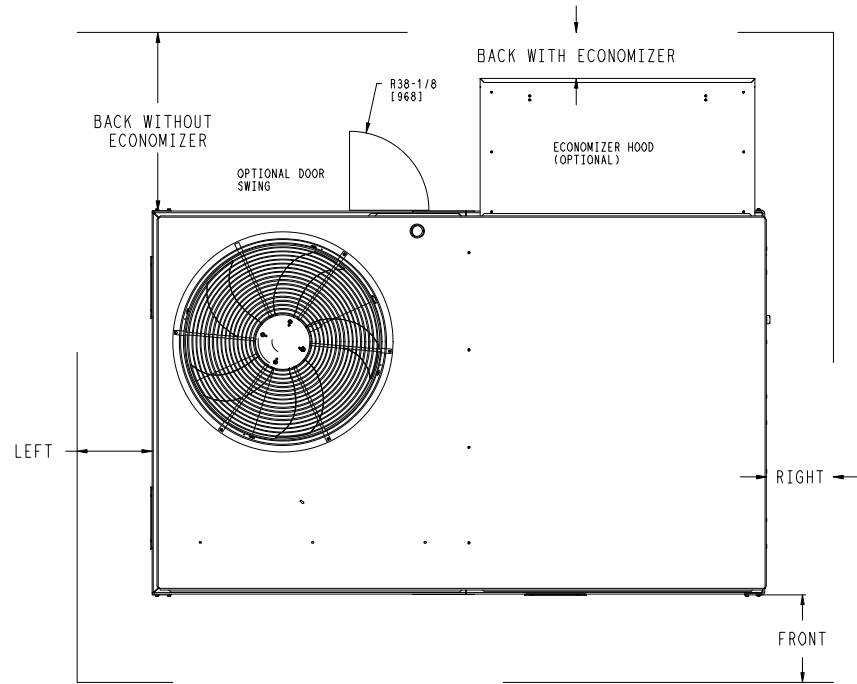
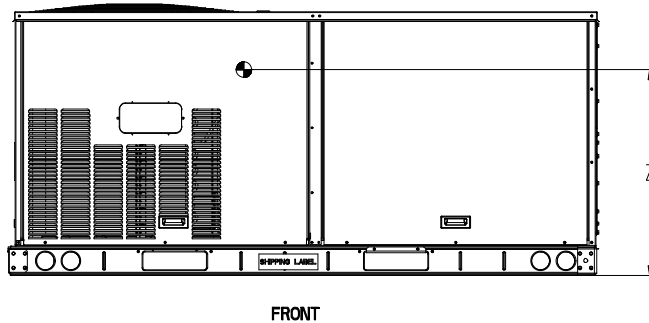
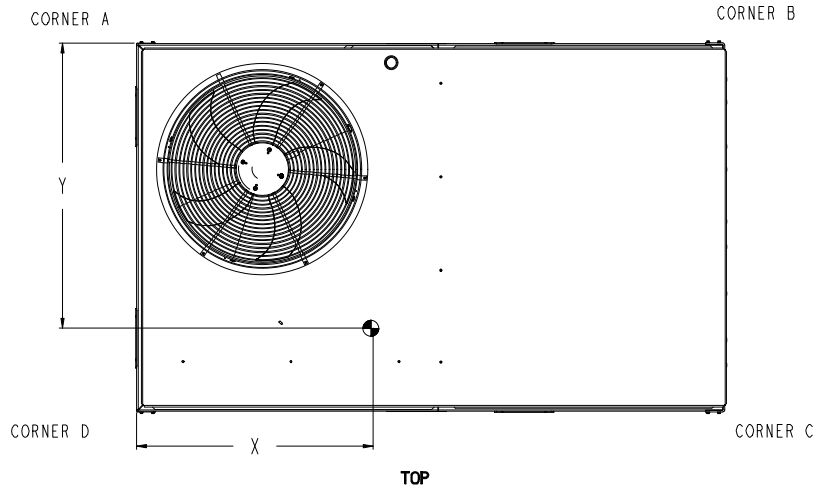

NOTE:

1. FOR ALL MINIMUM CLEARANCES LOCAL CODES OR JURISDICTIONS MAY PREVAIL.

| SURFACE       | CLEARANCE                       |                                    | OPERATING CLEARANCE |
|---------------|---------------------------------|------------------------------------|---------------------|
|               | SERVICE WITH CONDUCTIVE BARRIER | SERVICE WITH NONCONDUCTIVE BARRIER |                     |
| FRONT         | 48 [1219mm]                     | 36 [914mm]                         | 18 [457mm]          |
| LEFT          | 48 [1219mm]                     | 42 [1067mm]                        | 18 [457mm]          |
| BACK W/O HOOD | 48 [1219mm]                     | 42 [1067mm]                        | 18 [457mm]          |
| BACK W/HOOD   | 36 [914mm]                      | 36 [914mm]                         | 18 [457mm]          |
| RIGHT         | 36 [914mm]                      | 36 [914mm]                         | 18 [457mm]          |
| TOP           | 72 [1829mm]                     | 72 [1829mm]                        | 72 [1829mm]         |

|                                      |                 |                 |                       |   |            |          |
|--------------------------------------|-----------------|-----------------|-----------------------|---|------------|----------|
| ITC CLASSIFICATION<br>U.S. ECCN: NSR | SHEET<br>2 OF 3 | DATE<br>5/16/24 | SUPERCEDES<br>9/15/23 | 50GE 04-06 SINGLE PACKAGE ELECTRICAL COOLING WITH ELECTRIC HEAT | 48TC006644 | REV<br>A |
|--------------------------------------|-----------------|-----------------|-----------------------|---|------------|----------|

# Certified Drawing for RTU 5

Project: Nike 202 Chesterfield MO  
 Prepared By: Dan Dillman

01/24/2025  
 10:26AM

|   |   |   |
|---|---|---|
|  | THIS DOCUMENT IS THE PROPERTY OF CARRIER CORPORATION AND IS DELIVERED UPON THE EXPRESS CONDITION THAT THE CONTENTS WILL NOT BE DISCLOSED OR USED WITHOUT CARRIER CORPORATION'S WRITTEN CONSENT. | SUBMISSION OF THESE DRAWINGS OR DOCUMENTS DOES NOT CONSTITUTE PART PERFORMANCE OR ACCEPTANCE OF CONTRACT. |
|---|---|---|

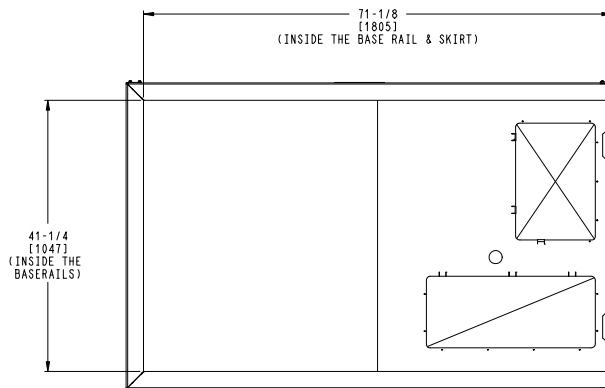
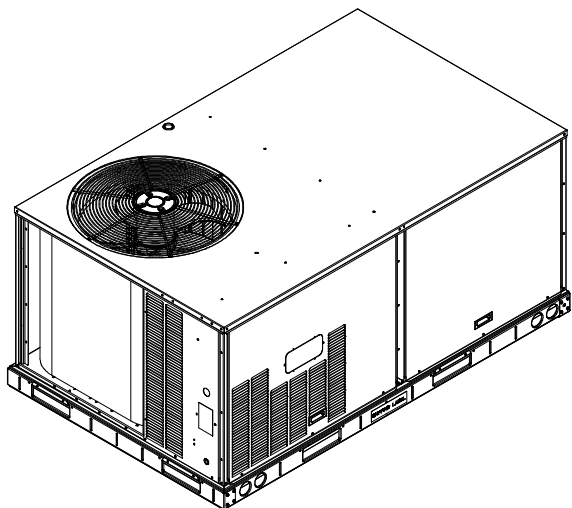

INSIDE BASERAIL DIMENSIONS  
**BOTTOM**

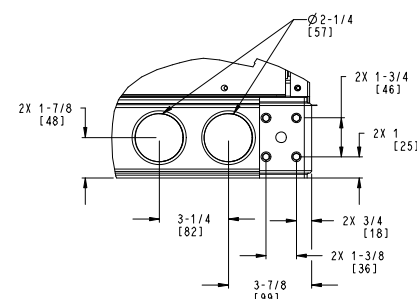

DETAIL **C**  
 TYP 4 PLCS

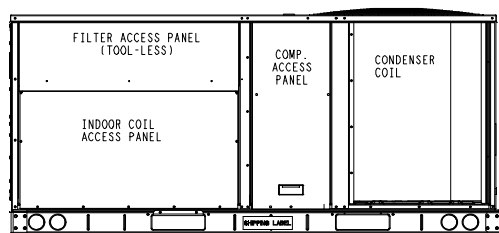

**BACK**

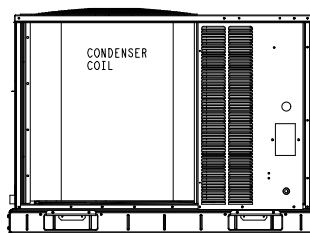

**LEFT**

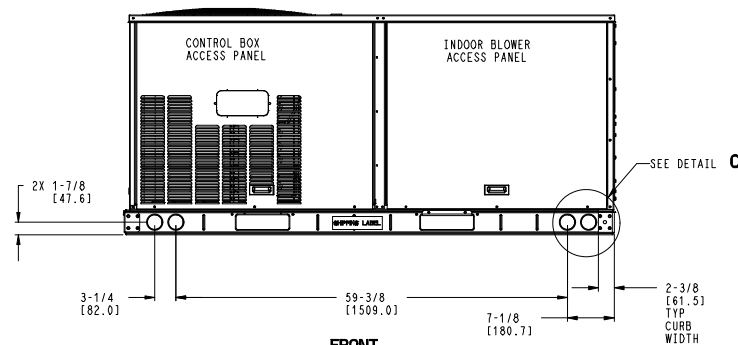

**FRONT**

|                    |        |         |            |   |            |          |
|--------------------|--------|---------|------------|---|------------|----------|
| ITC CLASSIFICATION | SHEET  | DATE    | SUPERCEDES | 50GE 04-06 SINGLE PACKAGE ELECTRICAL COOLING WITH ELECTRIC HEAT | 48TC006644 | REV<br>A |
| U.S. ECCN: NSR     | 3 OF 3 | 5/16/24 | 9/15/23    |   |            |          |

# Performance Summary For RTU 5

Project: Nike 202 Chesterfield MO  
Prepared By: Dan Dillman

01/24/2025  
10:26AM

## Part Number:50GE-N06A2M6-3W4F0

Refrigerant:..... **R-454B**  
ARI SEER:..... **17.20**  
ARI SEER2:..... **16.80**

### Base Unit Dimensions

Unit Length:..... **74.4** in  
Unit Width:..... **46.6** in  
Unit Height:..... **41.4** in

### Operating Weight

Base Unit Weight:..... **600** lb  
Two Stage Cooling, Single Circuit with Humidimizer:..... **33** lb  
Al/Cu - Al/Cu - Louvered Hail Guards:..... **17** lb  
SystemVu Controller:..... **2** lb  
ULL Enthalpy Economizer with Barometric Relief:..... **37** lb  
Hinged Panels and Unpowered Convenience Outlet:..... **9** lb  
Non-Fused Disconnect and Thru-The-Base Connections:..... **9** lb

### Accessories

Electric Heater:..... **10** lb  
  
Total Operating Weight:..... **717** lb

### Unit

Unit Voltage-Phase-Hertz:..... **460-3-60**  
Air Discharge:..... **Vertical**  
Fan Drive Type:..... **Vane Axial**  
Actual Airflow:..... **1750** CFM  
Site Altitude:..... **564** ft

### Cooling Performance

Condenser Entering Air DB:..... **100.0** F  
Evaporator Entering Air DB:..... **75.9** F  
Evaporator Entering Air WB:..... **62.6** F  
Evaporator Entering Air Enthalpy:..... **28.43** BTU/lb  
Evaporator Leaving Air DB:..... **54.0** F  
Evaporator Leaving Air WB:..... **51.8** F  
Evaporator Leaving Air Enthalpy:..... **21.47** BTU/lb  
Gross Cooling Capacity:..... **53.73** MBH  
Gross Sensible Capacity:..... **40.54** MBH  
Compressor Power Input:..... **4.06** kW  
Coil Bypass Factor:..... **0.030**

### Part Load (SubCooling Mode)

Condenser Entering Air DB:..... **95.0** F  
Evaporator Entering Air DB:..... **80.0** F  
Evaporator Entering Air WB:..... **67.0** F  
Entering Air Enthalpy:..... **31.76** BTU/lb  
Entering Air Relative Humidity:..... **51.4** %  
Humidi-MiZer(R) Coil Leaving Air DB:..... **64.0** F  
Humidi-MiZer(R) Coil Leaving Air WB:..... **57.2** F  
Humidi-MiZer(R) Coil Leaving Air Enthalpy:..... **24.72** BTU/lb  
Leaving Air Relative Humidity:..... **66.6** %  
Grains Per LB Removed:..... **19.9**  
Moisture gal/hr Removed:..... **2.6**  
Gross Sensible Heat Ratio:..... **0.544**  
Gross Cooling Capacity:..... **54.33** MBH  
Gross Sensible Capacity:..... **29.58** MBH  
Compressor Power Input:..... **5.44** kW

### Dehumidification (Hot Gas Reheat Mode)

## Performance Summary For RTU 5

Project: Nike 202 Chesterfield MO  
 Prepared By: Dan Dillman

01/24/2025  
 10:26AM

|  |        |        |
|--|--------|--------|
| Condenser Entering Air DB:                 | 75.0   | F      |
| Evaporator Entering Air DB:                | 75.0   | F      |
| Evaporator Entering Air WB:                | 64.0   | F      |
| Entering Air Enthalpy:                     | 29.45  | BTU/lb |
| Entering Air Relative Humidity:            | 55.4   | %      |
| Humidi-MiZer(R) Coil Leaving Air DB:       | 76.4   | F      |
| Humidi-MiZer(R) Coil Leaving Air WB:       | 59.7   | F      |
| Humidi-MiZer(R) Coil Leaving Air Enthalpy: | 26.32  | BTU/lb |
| Leaving Air Relative Humidity:             | 37.2   | %      |
| Grains Per LB Removed:                     | 22.0   |        |
| Moisture gal/hr Removed:                   | 2.9    |        |
| Gross Sensible Heat Ratio:                 | -0.107 |        |
| Gross Cooling Capacity:                    | 24.19  | MBH    |
| Gross Sensible Capacity:                   | -2.58  | MBH    |
| Compressor Power Input:                    | 3.04   | kW     |

### Mixed Air

|                         |       |     |
|-------------------------|-------|-----|
| Outdoor Air Airflow:    | 165   | CFM |
| Outdoor Air DB:         | 100.0 | F   |
| Outdoor Air WB:         | 76.0  | F   |
| Outdoor Air Htg. Temp.: | 2.0   | F   |
| Return Air DB:          | 73.4  | F   |
| Return Air WB:          | 61.0  | F   |
| Return Air Htg. Temp.:  | 63.9  | F   |

### Heating Performance

|                            |       |     |
|----------------------------|-------|-----|
| Heating Airflow:           | 1750  | CFM |
| Entering Air Temp:         | 58.1  | F   |
| Leaving Air Temp:          | 81.8  | F   |
| Electric Heating Capacity: | 12.90 | kW  |

### Supply Fan

|   |                                     |       |
|---|-------------------------------------|-------|
| External Static Pressure:                           | 0.80                                | in wg |
| Options / Accessories Static Pressure               |                                     |       |
| Electric Heaters:                                   | 0.20                                | in wg |
| Humidi-MiZer Dehumidification System:               | 0.10                                | in wg |
| Economizer:   | 0.09                                | in wg |
| Application External Static (ESP + Unit Opts/Acc.): | 1.19                                | in wg |
| Fan RPM:  | 2066                                |       |
| Fan Power:  | 0.93                                | BHP   |
| NOTE:   | Selected IFM RPM Range: 1228 - 2390 |       |

**Selection includes construction throwaway filter into the base fan curve. This filter is not MERV Rated.**

### Electrical Data

|                                   |           |
|-----------------------------------|-----------|
| Voltage Range:                    | 414 - 506 |
| Compressor #1 RLA:                | 6.7       |
| Compressor #1 LRA:                | 58        |
| Actual Electric Heater kW:        | 12.9      |
| Electric Heater FLA:              | 16.8      |
| Indoor Fan Motor Type:            | MED       |
| Indoor Fan Motor FLA (Total):     | 2.1       |
| Power Supply MCA:                 | 24        |
| Power Supply MOCP (Fuse or HACR): | 25        |
| Disconnect Size FLA:              | 22        |
| Disconnect Size LRA:              | 63        |
| Electrical Convenience Outlet:    | None      |
| Outdoor Fan [Qty / FLA (ea)]:     | 1 / 1.4   |
| Electric Heater Part Number:      | 336A      |
| Electric Heater Number of Stages: | 1         |

**Control Panel SCCR: 5kA RMS at Rated Symmetrical Voltage**

### Acoustics

# Performance Summary For RTU 5

Project: Nike 202 Chesterfield MO  
 Prepared By: Dan Dillman

01/24/2025  
 10:26AM

Sound Power Levels, db re 10E-12 Watts

|            | Discharge | Inlet | Outdoor |
|------------|-----------|-------|---------|
| 63 Hz      | 93.9      | 89.6  | 85.6    |
| 125 Hz     | 85.1      | 80.5  | 84.7    |
| 250 Hz     | 79.0      | 73.1  | 80.5    |
| 500 Hz     | 74.1      | 67.0  | 76.0    |
| 1000 Hz    | 70.9      | 68.7  | 72.4    |
| 2000 Hz    | 68.7      | 60.4  | 68.0    |
| 4000 Hz    | 64.4      | 53.6  | 62.8    |
| 8000 Hz    | 60.6      | 47.6  | 59.3    |
| A-Weighted | 78.0      | 72.9  | 79.0    |

### Advanced Acoustics

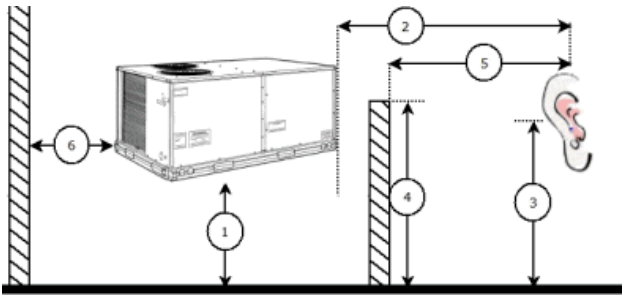

### Advanced Acoustics Parameters

- 1. Unit height above ground:.....**30.0** ft
- 2. Horizontal distance from unit to receiver:.....**50.0** ft
- 3. Receiver height above ground:.....**5.7** ft
- 4. Height of obstruction:.....**0.0** ft
- 5. Horizontal distance from obstruction to receiver:.....**0.0** ft
- 6. Horizontal distance from unit to obstruction:.....**0.0** ft

### Detailed Acoustics Information

| Octave Band Center Freq. Hz | 63   | 125  | 250  | 500  | 1k   | 2k   | 4k   | 8k   | Overall  |
|-----------------------------|------|------|------|------|------|------|------|------|----------|
| A                           | 85.6 | 84.7 | 80.5 | 76.0 | 72.4 | 68.0 | 62.8 | 59.3 | 89.2 Lw  |
| B                           | 59.4 | 68.6 | 71.9 | 72.8 | 72.4 | 69.2 | 63.8 | 58.2 | 78.5 LwA |
| C                           | 53.2 | 52.3 | 48.1 | 43.6 | 40.0 | 35.6 | 30.4 | 26.9 | 56.8 Lp  |
| D                           | 27.0 | 36.2 | 39.5 | 40.4 | 40.0 | 36.8 | 31.4 | 25.8 | 46.1 LpA |

### Legend

- A Sound Power Levels at Unit's Acoustic Center, Lw
- B A-Weighted Sound Power Levels at Unit's Acoustic Center, LwA
- C Sound Pressure Levels at Specific Distance from Unit, Lp
- D A-Weighted Sound Pressure Levels at Specific Distance from Unit, LpA

Calculation methods used in this program are patterned after the ASHRAE Guide; other ASHRAE Publications and the AHRI Acoustical Standards. While a very significant effort has been made to insure the technical accuracy of this program, it is assumed that the user is knowledgeable in the art of system sound estimation and is aware of the tolerances involved in real world acoustical estimation. This program makes certain assumptions as to the dominant sound sources and sound paths which may not always be appropriate to the real system being estimated. Because of this, no assurances can be offered that this software will always generate an accurate sound prediction from user supplied input data. If in doubt about the estimation of expected sound levels in a space, an

# Performance Summary For RTU 5

Project: Nike 202 Chesterfield MO  
Prepared By: Dan Dillman

01/24/2025  
10:26AM

Acoustical Engineer or a person with sound prediction expertise should be consulted.

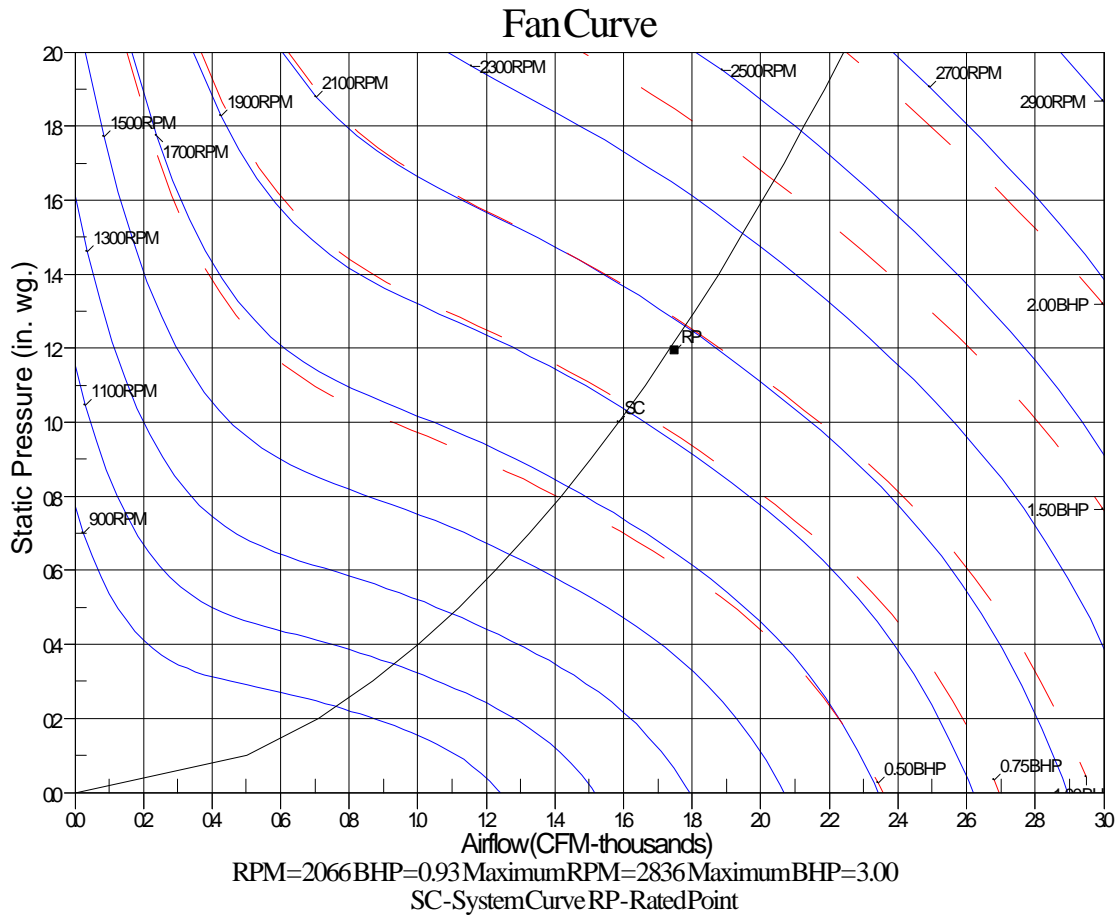

# Unit Feature Sheet for RTU 5

Project: Nike 202 Chesterfield MO  
Prepared By: Dan Dillman

01/24/2025  
10:26AM



## WeatherMaster®

### PURON ADVANCE™ PACKAGED ROOFTOP GAS HEATING/ELECTRIC COOLING UNITS 3, 4, 5 TONS – 16.8 SEER2

50GE units are single-packaged electric cooling, gas heating rooftops. All units are prewired and pre-charged with Carrier's new, low global warming potential Puron Advance™ (R-454B) refrigerant. Puron Advance represents a 75% reduction in refrigerant GWP over legacy Puron™ (R-410A) models. All units are factory tested in both heating and cooling modes. 3–5-ton models use single stage cooling capacity control. 6-ton model uses two stage cooling capacity control.



Use of the AHRI Certified TM Mark indicates a manufacturer's participation in the program. For verification of certification for individual products, go to [www.ahri.org](http://www.ahri.org).

Puron  
ADVANCE™

#### PERFORMANCE FEATURES

- Puron Advance (R-454B) refrigerant
- Two stage cooling capacity
- SEER2s up to 16.8
- New - A2L leak detection and dissipation system factory installed standard
- Leak system ensures unit and occupant safety during operation and includes an alarm relay for optional use
- Onboard recallable leak detection history for easier troubleshooting and service
- Direct Drive – EcoBlue™ Technology Indoor fan system uses Vane Axial fan design and electronically commutated motor
- New Unit Control Board with intuitive quick fan speed adjustment
- Sound levels as low as 76 dB
- Exclusive non-corrosive composite condensate pans in accordance with ASHRAE 62 Standard, sloping design; side or center drain
- Pre-painted exterior panels and primer-coated interior panels tested to 500 hours salt spray protection
- TXV refrigerant metering systems
- Fully insulated cabinet
- Standard cooling operating range up to 125°F (46°C), and down to 40°F (4°C). Low Ambient allows cooling operation down to -20°F (-29°C).
- Rated in accordance with AHRI Standards 210/240
- Designed in accordance with Underwriters' Laboratories Standard UL 60335-1 and UL 60335-2-40
- Listed by UL and CUL-Canada

#### MAINTENANCE FEATURES

- Large access panels with easy grip handles
- Innovative, easy starting, no-strip screw feature on unit access panels
- Two-inch disposable return air filters
- Tool-less filter access door
- New central terminal board facilitating simple safety circuit troubleshooting and simplified control box arrangement

#### INSTALLATION FEATURES

- Field Convertible from vertical to horizontal airflow on all models. No special kit required.
- Provisions for thru-the-bottom power entry capability
- Single point electric connections
- Full perimeter base rail with built-in rigging adapters and fork truck slots
- Two stage cooling thermostats required to provide great energy and comfort solutions

#### STANDARD LIMITED PARTS WARRANTY

- 5-year compressor parts
- 5-year electric heater
- 3-year SystemVu™ controller
- 1-year parts

#### AVAILABLE OPTIONS:

- Patented Humidi-MiZer® adaptive dehumidification system. This option also includes Low Ambient controls
- Through the base connections for electric available as option
- Disconnect, HACR and convenience outlet options
- Multi static indoor fan motor options
- Smoke detector, supply and/or return air
- Corrosion resistant options for evaporator and condenser coils
- CO2 Sensor
- Phase Monitor Protection
- 4" MERV-13 Filters
- Low ambient operation controls
- Factory or field installed electric heat
- Foil faced insulation
- 2-position damper (field installed only)
- Hinged access panels
- Integrated economizer system. Low and ULTRA Low Leak versions.
- Condensate overflow switch
- SystemVu Controls