

DUCTWORK #1 PARTS - JOB#4707156 DUCT

TAG	PART #	CFM	GPM	ZONE	COVEREDBY	SP	WEIGHT	VELOCITY	QTY	DESCRIPTION
P1	DW1490ASY	1750				-0.1348	10.62	1637.02	1	SINGLE WALL DUCT 90 DEGREE ELBOW, 14" DUCT, ASSEMBLY.
P2	DW1404C1D	1750				-0.002	2.45	1637.02	1	SINGLE WALL DUCT OFF SET COLLAR - 14" DIAMETER DUCT - 1/4" PITCH.
P3	DW1417LT	1750				-0.007	8.22	1637.02	1	SINGLE WALL DUCT 14" DIAMETER, 17" LONG, FLANGE AT BOTH ENDS. STAINLESS STEEL.
P4	DW1424AJDKIT	1750				-0.005	14.56	1637.02	1	SINGLE WALL DUCT ADJUSTABLE, 14" DIAMETER, 23.5" LONG, FLANGE AT ONE END WITH A 14" ADJUSTABLE COLLAR - STAINLESS STEEL.
P5	DW1404C1D	1750				-0.002	2.45	1637.02	1	SINGLE WALL DUCT OFF SET COLLAR - 14" DIAMETER DUCT - 1/4" PITCH.
P6 ASSEMBLED W/P8	DW14TEASY	1750		1		-0.01	15.95	1637.02	1	SINGLE WALL DUCT TEE, 14" DUCT, ASSEMBLY.
P7	DW1420ADPEC	1750				-0.092	8.99	1637.02	1	SINGLE WALL DUCT ADAPTER, 14" DUCT DIA TO 20" DUCT DIA, ECCENTRIC ASSEMBLY.
SYSTEM AT P7						-1.0688	0.00			
P8 ASSEMBLED W/P6 D=T	DW1415ADIASY						13.89		1	DUCT ACCESS DOOR - INSULATED - USED WITH 14" DUCT - GREASE DAM INCLUDED - ASSEMBLY.
P9	DW14SUBRASY						2.96		1	DUCT SUPPORT BRACKET KIT, 14" DUCT, USED FOR HANGING DUCT. 12 GA STEEL, CLEAR ZINC COATING - 2 RINGS, 4 BRACKETS, & HARDWARE BAG 2.
P10	DW1490ASY	1710				-0.1278	10.62	1599.60	1	SINGLE WALL DUCT 90 DEGREE ELBOW, 14" DUCT, ASSEMBLY.
P11	DW1445ASY	1710				-0.0968	7.22	1599.60	1	SINGLE WALL DUCT 45 DEGREE ELBOW, 14" DUCT, ASSEMBLY.
P12	DW1404C2D	1710				-0.001	2.47	1599.60	1	SINGLE WALL DUCT OFF SET COLLAR - 14" DIAMETER DUCT - 1/2" PITCH.
P13	DW1411LT	1710				-0.004	5.46	1599.60	1	SINGLE WALL DUCT 14" DIAMETER, 11" LONG, FLANGE AT BOTH ENDS. STAINLESS STEEL.
P14	DW1418AJDKIT	1710				-0.004	11.56	1599.60	1	SINGLE WALL DUCT ADJUSTABLE, 14" DIAMETER, 17.5" LONG, FLANGE AT ONE END WITH A 14" ADJUSTABLE COLLAR - STAINLESS STEEL.
P15	DW1404C2D	1710				-0.001	2.47	1599.60	1	SINGLE WALL DUCT OFF SET COLLAR - 14" DIAMETER DUCT - 1/2" PITCH.
P16 ASSEMBLED W/P19	DW14TEASY	1710		1		-0.01	15.95	1599.60	1	SINGLE WALL DUCT TEE, 14" DUCT, ASSEMBLY.
P17	DW1416ADPEC	1710				-0.008	7.50	1599.60	1	SINGLE WALL DUCT ADAPTER, 14" DUCT DIA TO 16" DUCT DIA, ECCENTRIC ASSEMBLY.
P18	DW1624ADPEC	1710				-0.075	11.20	1224.70	1	SINGLE WALL DUCT ADAPTER, 16" DUCT DIA TO 24" DUCT DIA, ECCENTRIC ASSEMBLY.
SYSTEM AT P18						-1.1296	0.00			
P19 ASSEMBLED W/P16 D=T	DW1415ADIASY						13.89		1	DUCT ACCESS DOOR - INSULATED - USED WITH 14" DUCT - GREASE DAM INCLUDED - ASSEMBLY.
P20	DW14SUBRASY						2.96		1	DUCT SUPPORT BRACKET KIT, 14" DUCT, USED FOR HANGING DUCT. 12 GA STEEL, CLEAR ZINC COATING - 2 RINGS, 4 BRACKETS, & HARDWARE BAG 2.
P21	DW1890ASY	2700				-0.1278	15.59	1527.89	1	SINGLE WALL DUCT 90 DEGREE ELBOW, 18" DUCT, ASSEMBLY.
P22	DW1804C1D	2700				-0.001	3.12	1527.89	1	SINGLE WALL DUCT OFF SET COLLAR - 18" DIAMETER DUCT - 1/4" PITCH.
P23	DW1811LT	2700				-0.002	6.99	1527.89	1	SINGLE WALL DUCT 18" DIAMETER, 11" LONG, FLANGE AT BOTH ENDS. STAINLESS STEEL.
P24	DW1845ASY	2700				-0.0933	10.24	1527.89	1	SINGLE WALL DUCT 45 DEGREE ELBOW, 18" DUCT, ASSEMBLY.
P25	DW1845ASY	2700				-0.0255	10.24	1527.89	1	SINGLE WALL DUCT 45 DEGREE ELBOW, 18" DUCT, ASSEMBLY.
P26 ASSEMBLED W/P33	DW18TEASY	2700		1		-0.006	22.75	1527.89	1	SINGLE WALL DUCT TEE, 18" DUCT, ASSEMBLY.
P27	DW1804C1D	2700				-0.001	3.12	1527.89	1	SINGLE WALL DUCT OFF SET COLLAR - 18" DIAMETER DUCT - 1/4" PITCH.
P28	DW18TEASY			1		-0.011	22.75		1	SINGLE WALL DUCT TEE, 18" DUCT, ASSEMBLY.
P29 ASSEMBLED W/P30	DW1804C2D						3.12		1	SINGLE WALL DUCT OFF SET COLLAR - 18" DIAMETER DUCT - 1/2" PITCH.
P30 ASSEMBLED W/P29	DW1819ADIASY						19.40		1	DUCT ACCESS DOOR - INSULATED - USED WITH 18" DUCT - GREASE DAM INCLUDED - ASSEMBLY.
P31	DW1817LT						10.56		1	SINGLE WALL DUCT 18" DIAMETER, 17" LONG, FLANGE AT BOTH ENDS. STAINLESS STEEL.
P32	DW18SUBRASY						3.38		1	DUCT SUPPORT BRACKET KIT, 18" DUCT, USED FOR HANGING DUCT. 12 GA STEEL, CLEAR ZINC COATING - 2 RINGS, 4 BRACKETS, & HARDWARE BAG 2.
P33 ASSEMBLED W/P26 D=T	DW1819ADIASY						19.40		1	DUCT ACCESS DOOR - INSULATED - USED WITH 18" DUCT - GREASE DAM INCLUDED - ASSEMBLY.
	3M-2000PLUS						0.80		10	DUCT - 3M FIRE BARRIER 2000 PLUS SILICONE - USED AS SEALANT TO SEAL DUCT JOINTS.
	DW14CLASY						1.06		17	DUCT *V* CLAMP WITH NEW DESIGN 14 GA BRACKETS, 14" DUCT, ASSEMBLY.
	DW16CLASY						1.18		1	DUCT *V* CLAMP WITH NEW DESIGN 14 GA BRACKETS, 16" DUCT, ASSEMBLY.
	DW18CLASY						1.30		13	DUCT *V* CLAMP WITH NEW DESIGN 14 GA BRACKETS, 18" DUCT, ASSEMBLY.
	DW20CLASY						1.41		1	DUCT *V* CLAMP WITH NEW DESIGN 14 GA BRACKETS, 20" DUCT, ASSEMBLY.
	DW24CLASY						1.65		1	DUCT *V* CLAMP WITH NEW DESIGN 14 GA BRACKETS, 24" DUCT, ASSEMBLY.
TOTAL WEIGHT							369.21			

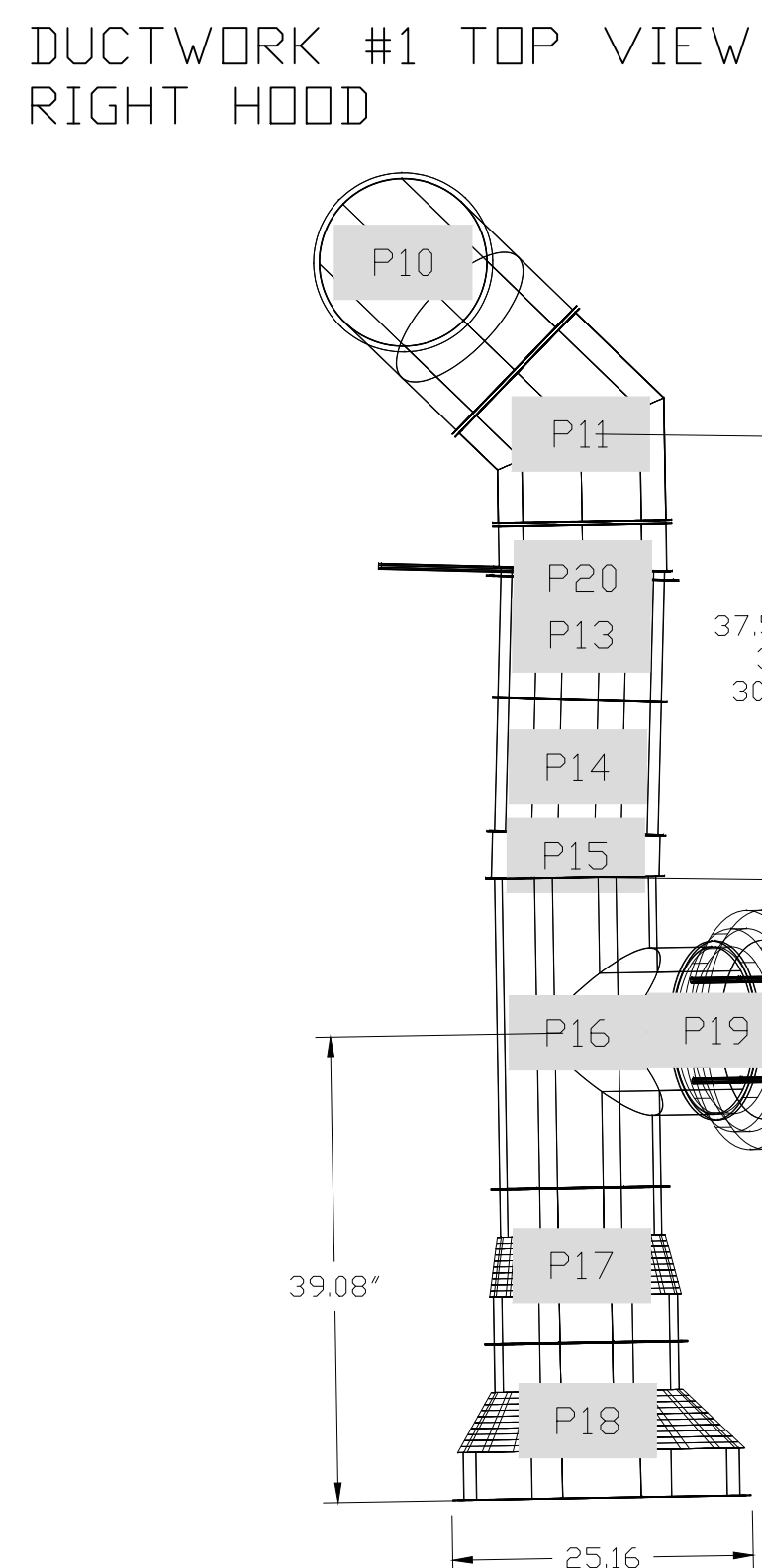
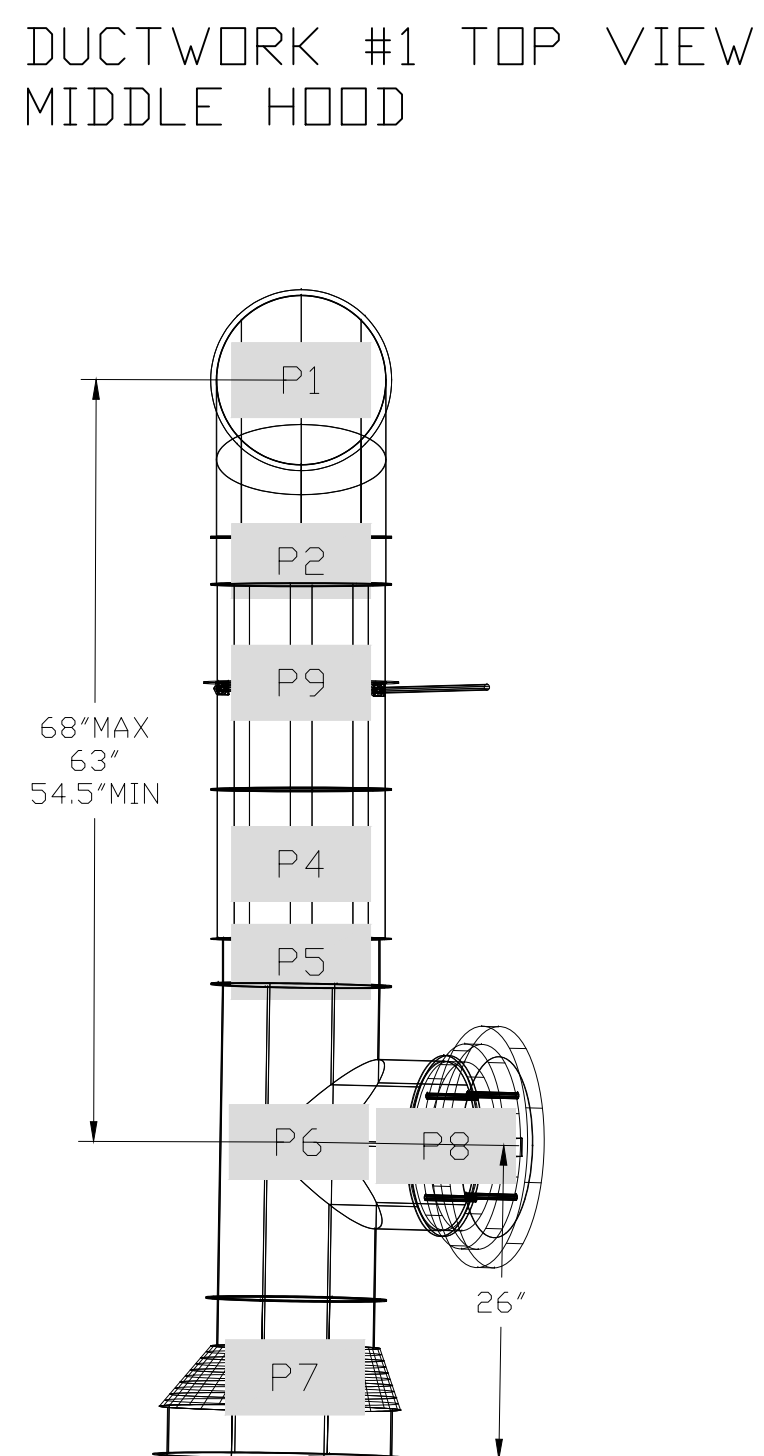
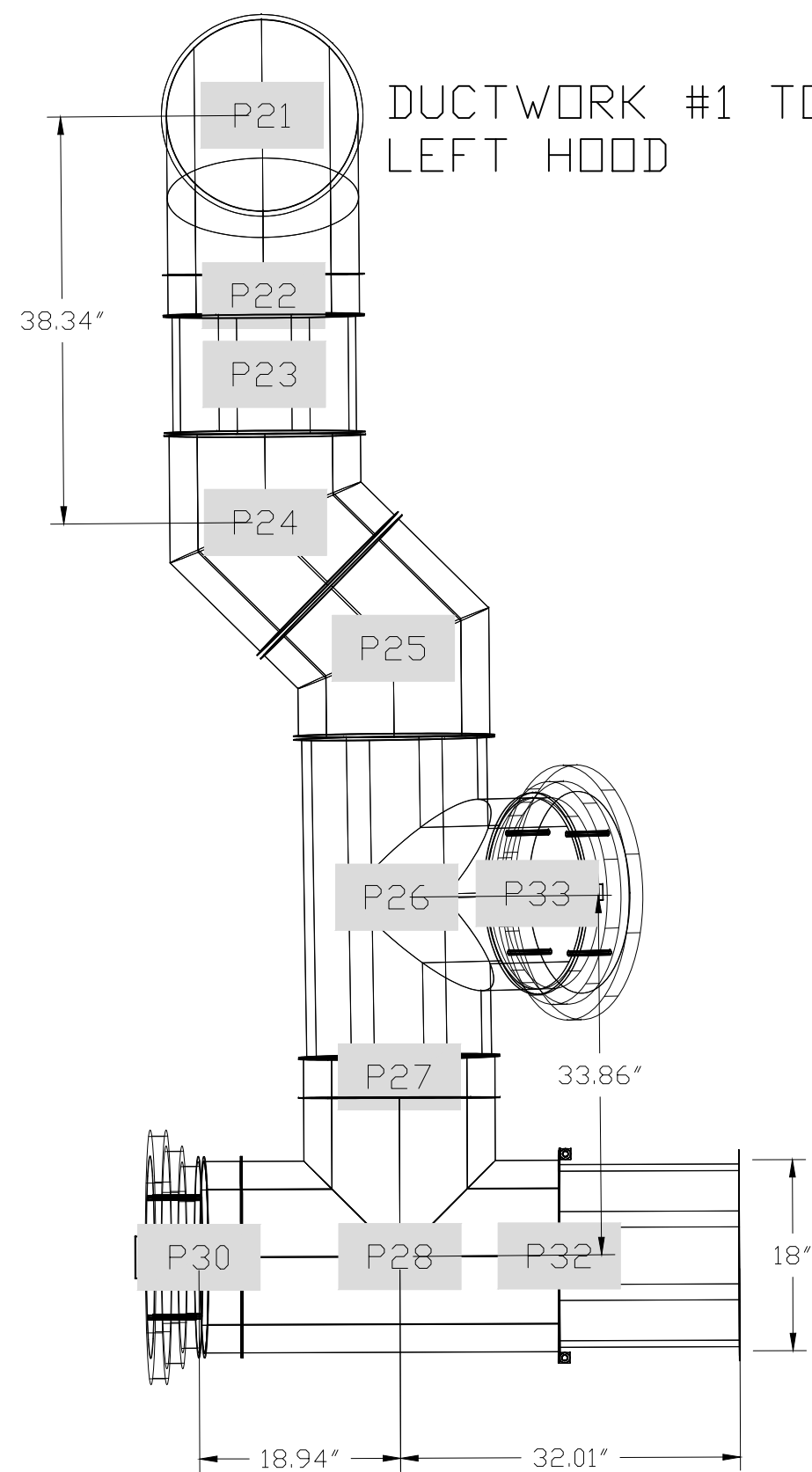
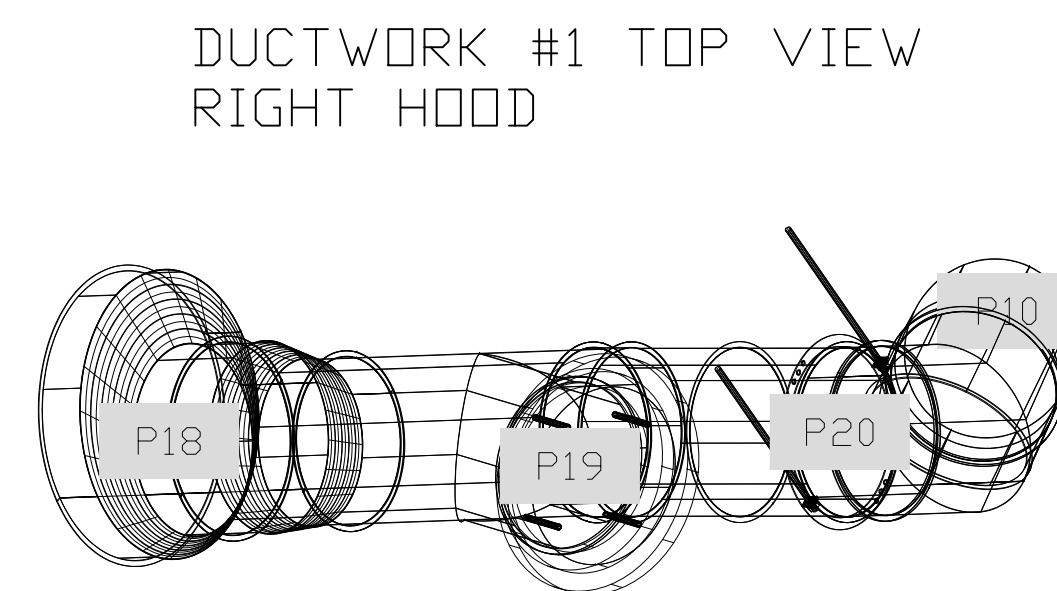
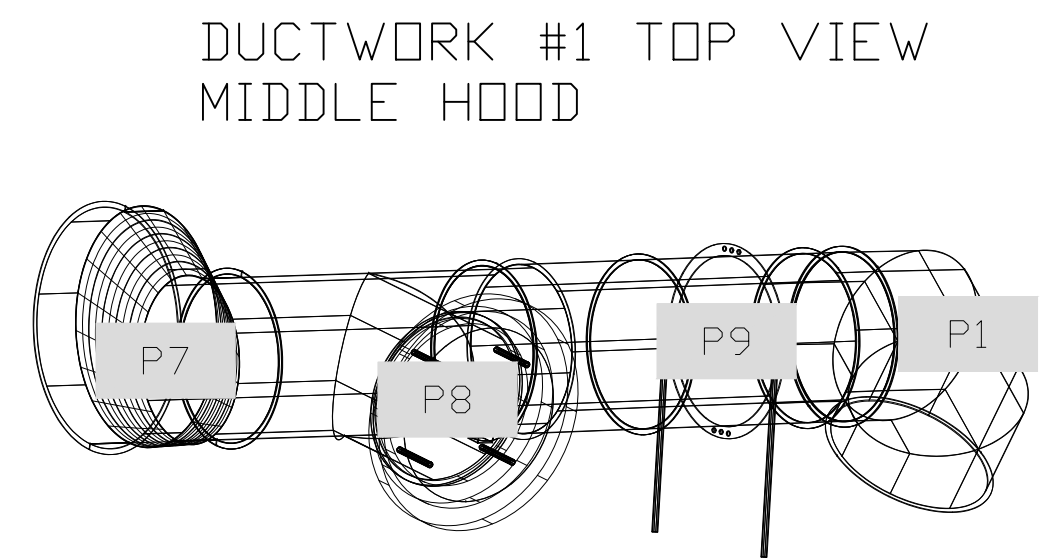
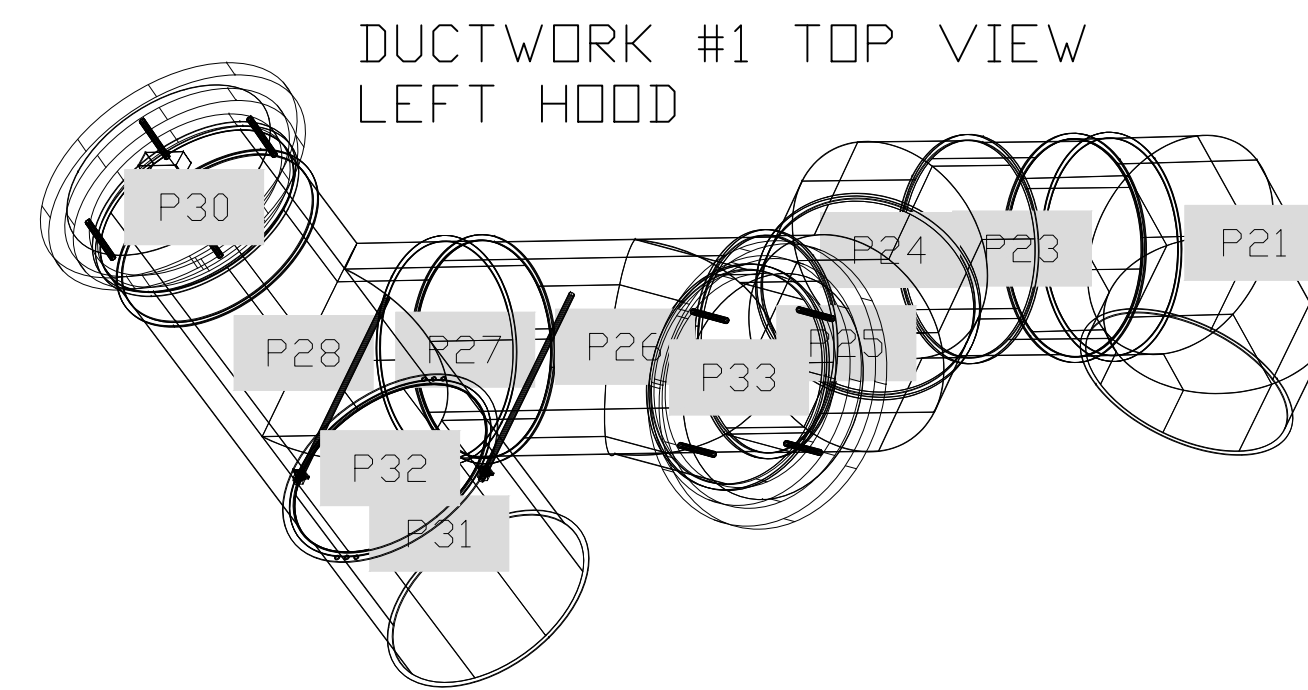

REVISIONS

DESCRIPTION	DATE



CAPTIVE
Air Solutions
www.captiveair.com
1329 East Kemper Rd., Ste. 4210, Cincinnati, OH, 45246 PHONE: (513) 860-5555 EMAIL: reg120@captiveair.com

Marquee REV 3 (Ft Wayne, IN)
123 W Columbia St,
Fort Wayne, IN, 46802

DATE: 9/15/2021
DWG.#: 4707156
DRAWN BY:
SCALE: Not To Scale
MASTER DRAWING

SHEET NO. 1