

# MECHANICAL SYMBOLS ABBREVIATIONS

(SOME SYMBOLS MAY NOT BE USED ON THE DRAWINGS)

%	PERCENT
ABS	ABSOLUTE
ACC	AIR-COOLED CHILLER
ACU	AIR CONDITIONING UNIT
AD	ACCESS DOOR
AF	AIR FOIL
AFF	ABOVE FINISHED FLOOR
AHU	AIR HANDLING UNIT
ALT	ALTITUDE
AMB	AMBIENT
AMCA	AIR MOVEMENT AND CONTROL ASSOCIATION
ANSI	AMERICAN NATIONAL STANDARDS INSTITUTE
APPROX	APPROXIMATE
ARI	AIR-CONDITIONING AND REFRIGERATION INSTITUTE
ASHRAE	AMERICAN SOCIETY OF HEATING, REFRIGERATION, AND AIR-CONDITIONING ENGINEERS
ASME	AMERICAN SOCIETY OF MECHANICAL ENGINEERS
ASTM	AMERICAN SOCIETY OF TESTING MATERIALS
AVG	AVERAGE
B	BOILER
BD	BACKDRAFT DAMPER
BG	BELOW GRADE
BEMCS	BUILDING ENERGY MANAGEMENT AND CONTROL SYSTEM
BHP	BRAKE HORSEPOWER
BI	BACKWARD INCLINED
BOD	BOTTOM OF DUCT
BOP	BOTTOM OF PIPE
BTU	BRITISH THERMAL UNIT
BTUH	BTU PER HOUR
CD	COLD DECK
CF	CUBIC FEET
CFM	CUBIC FEET PER MINUTE
CHET	CHILLED WATER EXPANSION TANK
CMPR	COMPRESSOR
COND	CONDENSER
CRAC	COMPUTER ROOM AIR CONDITIONER
CT	COOLING TOWER
CHWR	CHILLED WATER RETURN
CHWS	CHILLED WATER SUPPLY
CU IN	CUBIC INCH
dB	DECIBEL
DB	DRY BULB
DCP	DISTRIBUTED CONTROL PANEL
DEG	DEGREE
DIA	DIAMETER
DWG	DRAWING
DX	DIRECT-EXPANSION
EAT	ENTERING AIR TEMPERATURE
EDH	ELECTRIC DUCT HEATER
EF	EXHAUST FAN
EFF	EFFICIENCY
EL	ELEVATION
ENT	ENTERING
ESP	EXTERNAL STATIC PRESSURE
EXP	EXPANSION
F	FAHRENHEIT
FA	FACE AREA
FCU	FAN COIL UNIT
FD	FIRE DAMPER
FH	FUME HOOD
FLEX	FLEXIBLE
FFM	FEET PER MINUTE
FPS	FEET PER SECOND
FRP	FIBERGLASS REINFORCED PIPE
FS	FLOW SWITCH
FSD	COMBINATION FIRE-SMOKE DAMPER
FT	FEET OR FOOT
FTU	FAN TERMINAL UNIT
GA	GAUGE OR GAGE
GAL	GALLONS
GALV	GALVANIZED
GPD	GALLONS PER DAY
GPH	GALLONS PER HOUR
GPM	GALLONS PER MINUTE
GR	GRAINS
H	ENTHALPY
HD	HEAD
HD	HOT DECK
HG	HEAT GAIN OR MERCURY
HGT	HEIGHT
HP	HORSEPOWER
HPS	HIGH PRESSURE STEAM
HR	HOUR
HTHW	HIGH TEMPERATURE HEATING WATER
HVAC	HEATING/VENTILATING/AIR-CONDITIONING
HVU	HEATING AND VENTILATING UNIT
HWR	HEATING HOT WATER RETURN
HWS	HEATING HOT WATER SUPPLY
HZ	FREQUENCY
ID	INSIDE DIAMETER
IPS	INTERNATIONAL PIPE STANDARD
ips	IRON PIPE SIZE
K	THERMAL CONDUCTIVITY
KH	KITCHEN HOOD
KW	KILOWATT

LAT	LEAVING AIR TEMPERATURE
LBS	POUNDS
LF	LINEAR FEET
LG	LENGTH
LPS	LOW PRESSURE STEAM
LTHW	LOW TEMPERATURE HOT WATER
LWT	LEAVING WATER TEMPERATURE
MCA	MINIMUM CIRCUIT AMPACITY
MOCP	MAXIMUM OVERCURRENT PROTECTION
MAX	MAXIMUM
MBH	BTU PER HOUR (THOUSAND)
MIN	MINIMUM
N.C.	NORMALLY CLOSED
N.O.	NORMALLY OPEN
N/A	NOT APPLICABLE
NC	NOISE CRITERIA
NIC	NOT IN CONTRACT
NTS	NOT TO SCALE
OA	OUTSIDE AIR
OBD	OPOSED BLADE DAMPER
OD	OUTSIDE DIAMETER
PD	PUMPED DISCHARGE
PBD	PARALLEL BLADE DAMPER
PH	PHASE (ELECTRICAL)
PPM	PARTS PER MILLION
PRESS	PRESSURE
PSF	POUNDS PER SQUARE FOOT
PSI	POUNDS PER SQUARE INCH
PSIA	PSI ABSOLUTE
PSIG	PSI GAGE
R	RANKINE
R-22	REFRIGERANT (NUMBER INDICATES TYPE)
RA	RETURN AIR
RAF	RELIEF AIR FAN
RECIRC	RECIRCULATE
RH	RELATIVE HUMIDITY
RHC	REHEAT COIL
RPM	REVOLUTIONS PER MINUTE
SA	SUPPLY AIR
SC	SHADING COEFFICIENT
SCFM	CUBIC FEET PER MINUTE-STANDARD CONDITIONS
SD	SMOKE DAMPER
SEC	SECOND
SF	SQUARE FEET
SG	SPECIFIC GRAVITY
SHG	SENSIBLE HEAT GAIN
SHR	SENSIBLE HEAT RATIO
SP	STATIC PRESSURE
SPEC	SPECIFICATION
SQ	SQUARE
SSD	SUB-SOIL DRAINAGE
STD	STANDARD
SUCT	SUCTION
t	TIME
T	TEMPERATURE SENSOR
TD	TEMPERATURE DIFFERENCE
TEMP	TEMPERATURE
TOC	TOP OF CONCRETE
TOD	TOP OF DUCT
TONS	TONS OF REFRIGERATION
TOP	TOP OF PIPE
TOS	TOP OF STEEL
TSP	TOTAL STATIC PRESSURE
T-STAT	THERMOSTAT
TU	TERMINAL UNIT
TYP	TYPICAL
U	HEAT TRANSFER COEFFICIENT
UH	UNIT HEATER
UF	UNDER FLOOR
V	VOLT
VA	VOLT AMPERE
VAC	VACUUM
VAV	VARIABLE AIR VOLUME
VD	VOLUME DAMPER
VENT	VENTILATION
VERT	VERTICAL
VFD	VARIABLE FREQUENCY DRIVE
VOL	VOLUME
VP	VELOCITY PRESSURE
W	HUMIDITY RATIO OR WATT
W.C.	WATER COLUMN
W.G.	WATER GAUGE
WB	WET BULB
WT	WEIGHT
YR	YEAR

## SHEET SYMBOLS

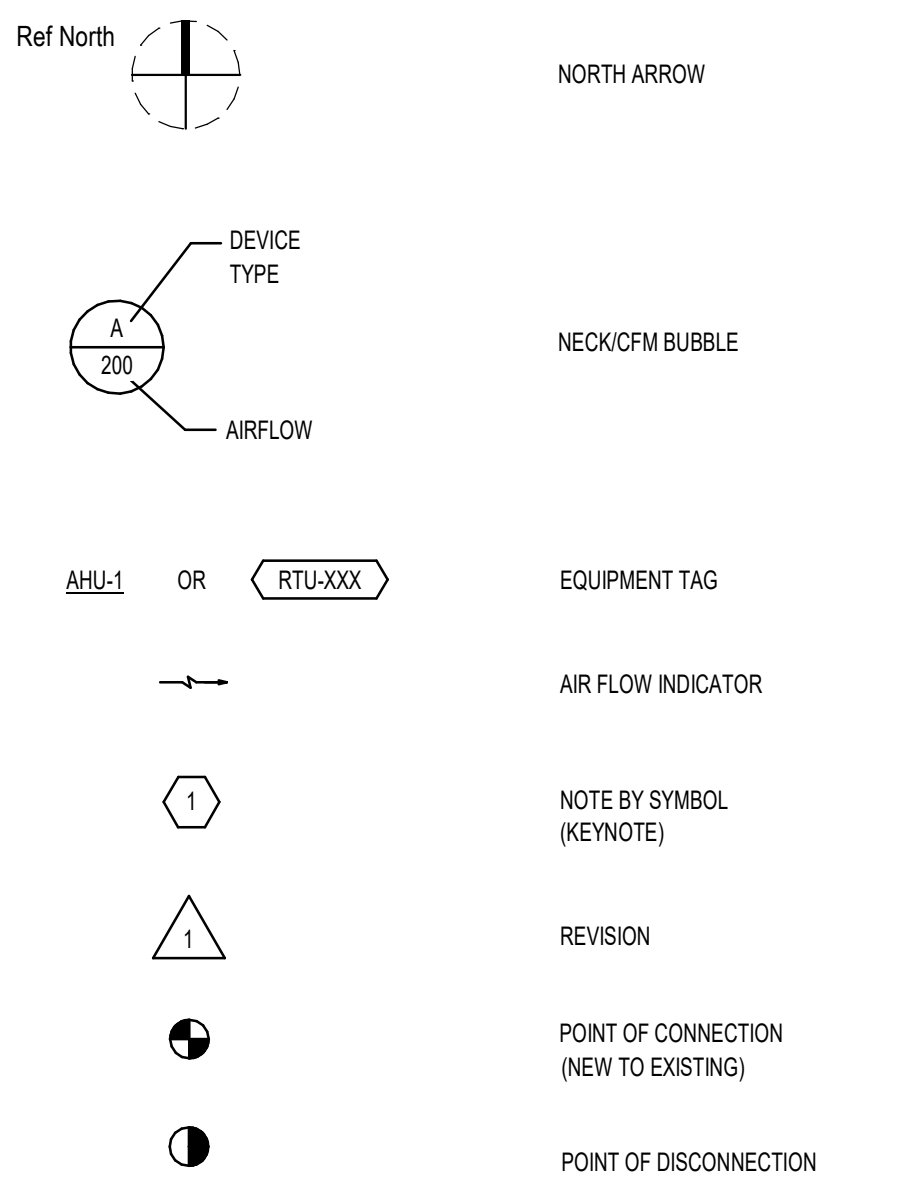
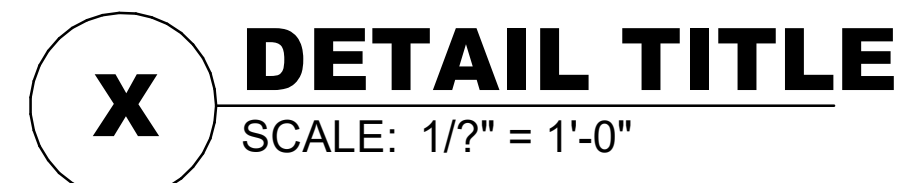

## MECHANICAL EQUIPMENT

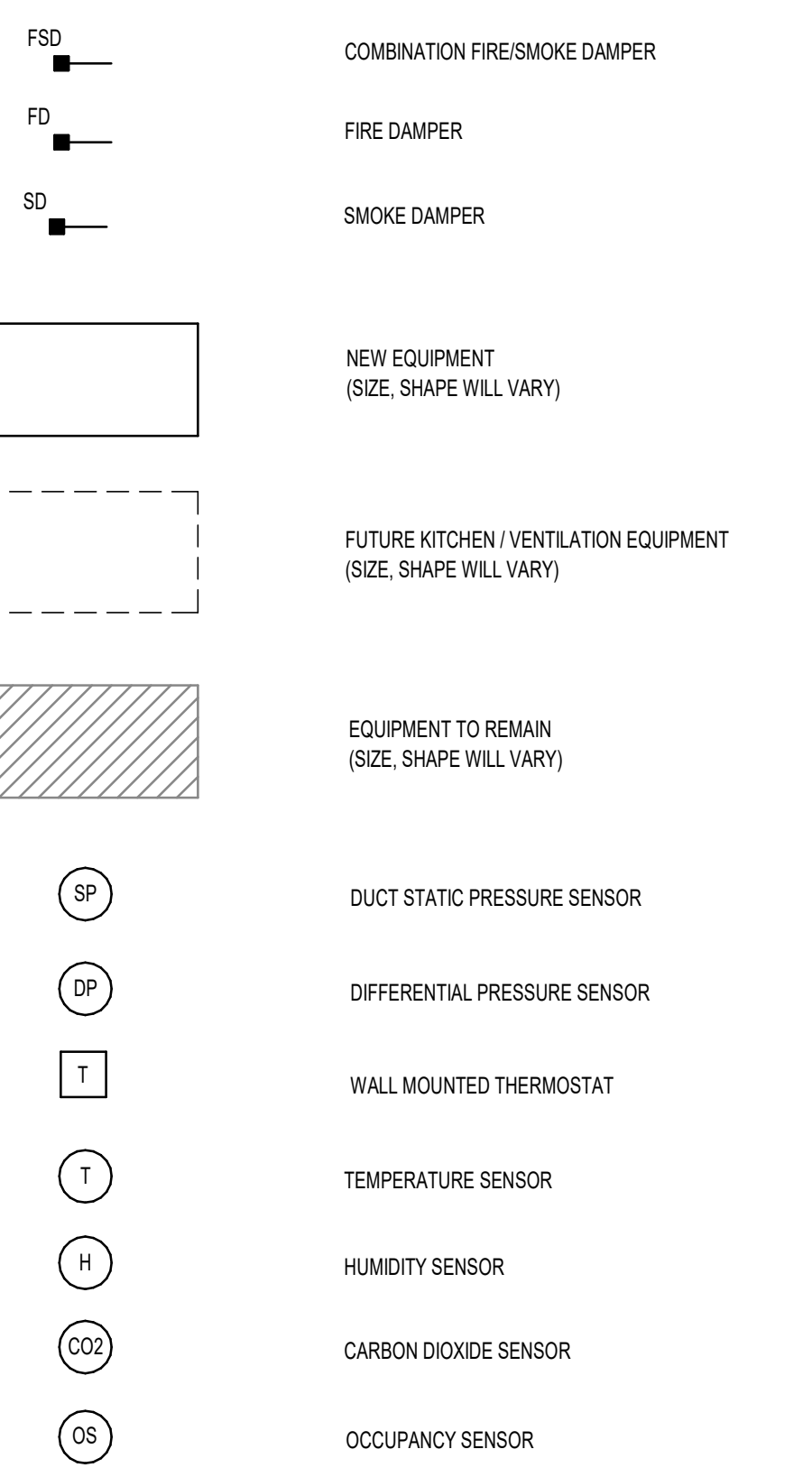

## DUCTWORK

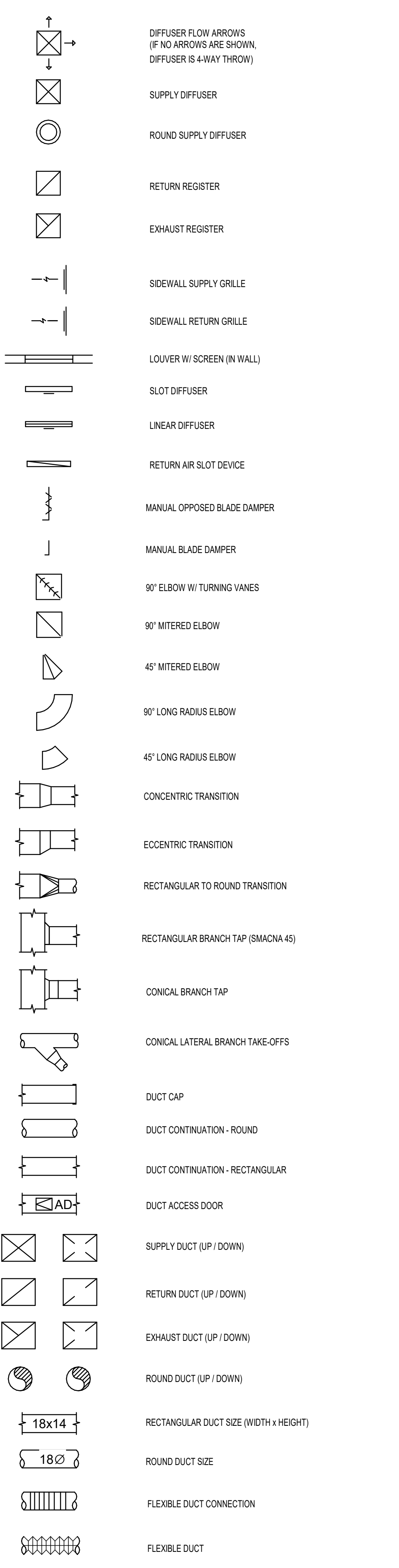

## DUCTWORK

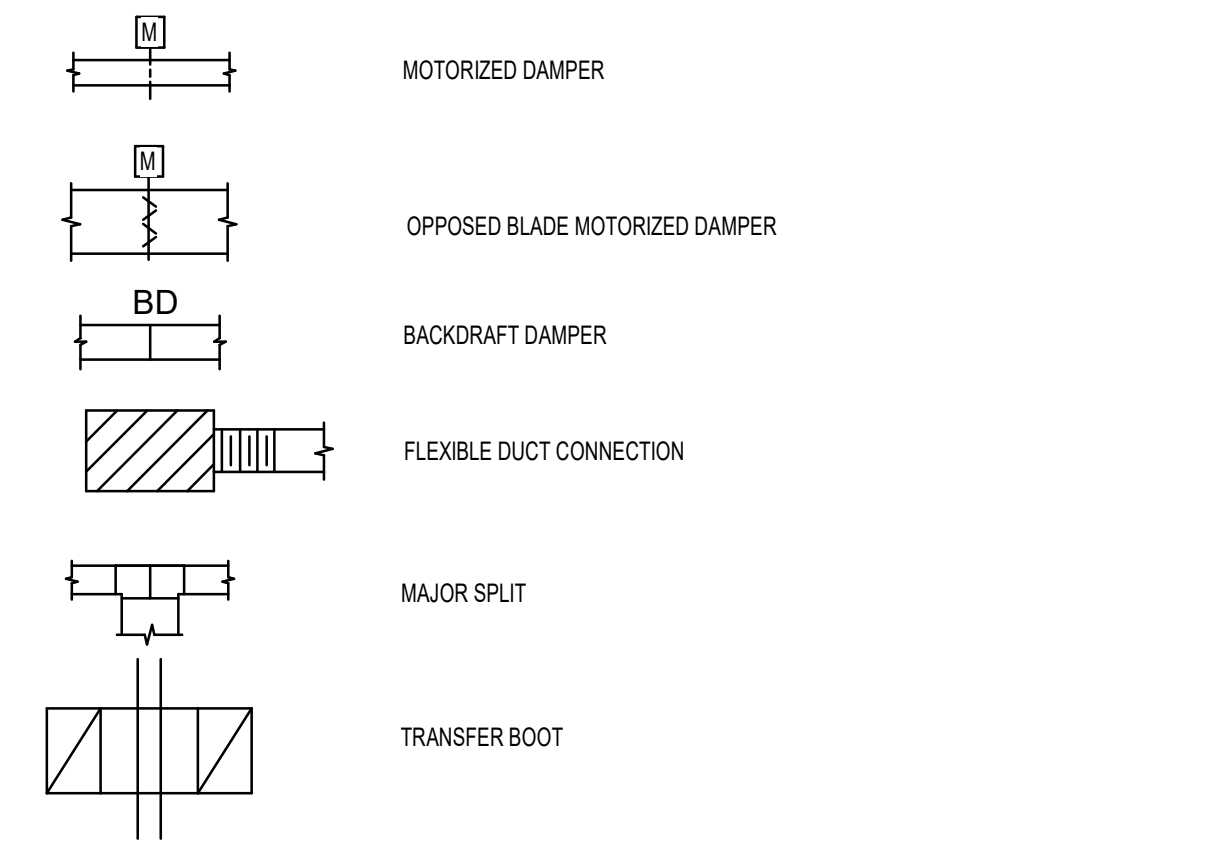

## PIPING SYMBOLS

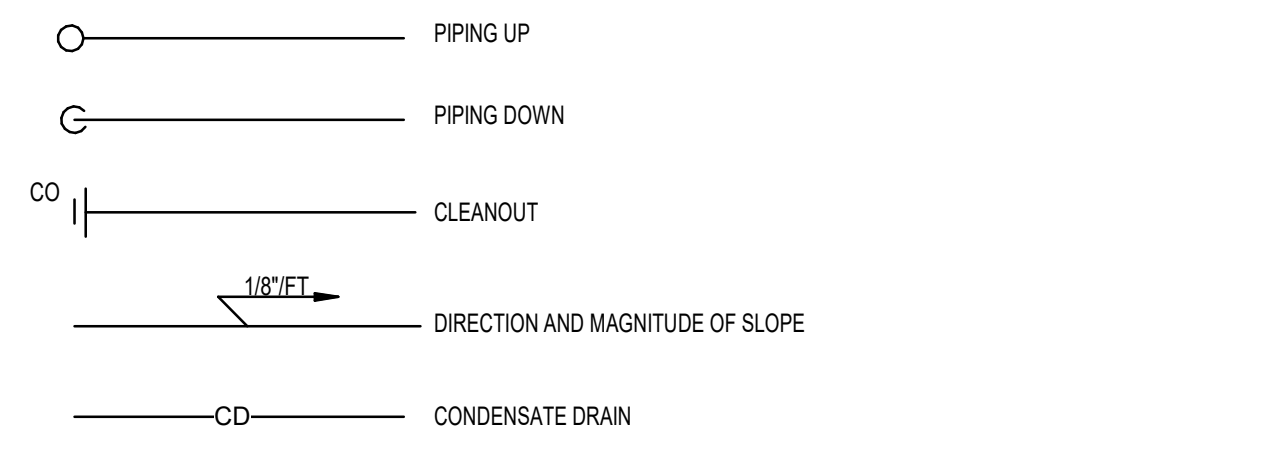

## HVAC DESIGN CRITERIA

<u>ASHRAE FUNDAMENTALS - 2021:</u>	<u>SUMMER COOLING DESIGN (0.4%):</u>
WEATHER STATION - FAIRHOPE 3 NE, AL	91.9 °F DRY BULB
ELEVATION: 95'	80.5 °F WET BULB
<u>WINTER HEATING DESIGN (99.6%):</u>	
26.2 °F DRY BULB	

## GENERAL NOTES

- PERFORM WORK IN ACCORDANCE WITH THE LATEST EDITIONS, REVISIONS, AMENDMENTS OR SUPPLEMENTS OF APPLICABLE STATUTES, ORDINANCES, CODES OR REGULATIONS OF FEDERAL, STATE AND LOCAL AUTHORITIES HAVING JURISDICTION IN EFFECT ON THE DATE BIDS ARE RECEIVED.
- PROVIDE ALL SYSTEMS AS COMPLETE WITH ALL REQUIRED ACCESSORIES FOR CODE COMPLIANCE.
- REFER TO SPECIFICATIONS FOR MATERIALS AND METHODS FOR CONSTRUCTION.
- DUCTWORK SIZES SHOWN ARE FREE AIR STREAM DIMENSIONS.
- INSTALL DUCTWORK AND PIPING TO PROVIDE THE MAXIMUM POSSIBLE CLEAR HEIGHT UNDERNEATH. (BETWEEN STRUCTURE OR CEILING AND TOP OF DUCT).
- WHERE APPROVAL CODES HAVE BEEN ESTABLISHED BY OSHA, UNDERWRITER'S LABORATORY, AMERICAN CODES, ANSI, ASME, ASA, ASHRAE, ASTM, ARI, NEL, NFPA, SMACNA, OR THE STATE FIRE INSURANCE REGULATORY BODY, FOLLOW THESE STANDARDS WHETHER OR NOT INDICATED ON THE DRAWINGS AND SPECIFICATIONS.
- PROVIDE THE ENTIRE SYSTEM AND ITS COMPONENT ITEMS OF EQUIPMENT IN OPERATING CONDITION FREE OF OBJECTIONABLE VIBRATION OR NOISE.
- COORDINATE WORK SO THAT INTERFERENCES BETWEEN PIPING, DUCTWORK, EQUIPMENT, PLUMBING WORK, ELECTRICAL WORK, AND BUILDING STRUCTURE WILL BE AVOIDED.
- FURNISH ACCESS DOORS FOR INSTALLATION IN WALLS AND CEILINGS WHERE ACCESS IS REQUIRED TO CONCEALED MECHANICAL EQUIPMENT, VALVES, DAMPERS, CONTROLS AND OTHER DEVICES.
- COORDINATE THE EXACT LOCATION OF DRAIN AND MECHANICAL EQUIPMENT LOCATIONS WITH MECHANICAL, ARCHITECTURAL, AND STRUCTURAL DRAWINGS PRIOR TO INSTALLATION.
- RECTANGULAR ELBOWS SHALL BE LONG-RADIUS ELBOWS UNLESS OTHERWISE SHOWN OR NOTED. SUPPLY AIR STANDARD NON-RADIUS 90° ELBOWS SHALL HAVE TURNING VANES.

PREPARED FOR:

**WHATABURGER**

**Architecture  
Engineering  
Environmental  
Land Surveying  
Companies**

3420 Torrington Way, Ste 210  
Charlotte, NC 28227  
(704) 565-7070  
(203) 630-2615 Fax

© 2024 BL COMPANIES, INC. THESE DRAWINGS SHALL NOT BE UTILIZED BY ANY PERSON, FIRM OR CORPORATION WITHOUT THE SPECIFIC WRITTEN PERMISSION OF BL COMPANIES.

Date	Description
------	-------------

Seal / Signature

Project Name

WHATABURGER DAPHNE, AL

Date: 10.16.2024

Project Number

2201817

Description

GENERAL NOTES, SYMBOLS AND ABBREVIATIONS

Scale

NOT TO SCALE

**M0.1**

C:\Users\panderson\Documents\2201817\_G2\_MECH\_Central\_RZ2\_OC\_panderson\GANC.rvt 12/20/2024 3:39:27 PM

### MECHANICAL KEY NOTES

- 1 24"x22" SUPPLY DUCT AND 48"x16" RETURN DUCT UP TO RTU-1. PROVIDE DUCT TRANSITIONS TO MATCH UNIT CONNECTION SIZE.
- 2 30"x12" SUPPLY DUCT AND 44"x14" RETURN DUCT UP TO RTU-2. PROVIDE DUCT TRANSITIONS TO MATCH UNIT CONNECTION SIZE.
- 3 SUPPLY AIR DUCT MOUNTED TEMPERATURE SENSOR. INSTALL ON BOTTOM OF DUCT.
- 4 CONNECT KITCHEN EXHAUST HOOD ABOVE GRILL UP TO KEF-1 WITH 16" DIA. PRE-FABRICATED UL 1978 LISTED AND LABELED GREASE DUCT (DRAVENT DIS1 OR EQUAL). PROVIDE TRANSITION ABOVE CEILING TO MATCH HOOD CONNECTION SIZE. CONNECT TO HOOD VIA MANUFACTURER'S UL METHOD FOR GREASE AND SMOKE TIGHT JOINT. INSTALL ACCORDING TO MANUFACTURER'S DIRECTIONS FOR NFPA 96 COMPLIANCE.
- 5 16" GREASE EXHAUST DUCT UP TO KEF-1 ON ROOF. RE: A2/M5.1
- 6 8"x8" EXHAUST DUCT UP TO EF-1 ON ROOF. RE: A1/M5.1
- 7 CONNECT KITCHEN EXHAUST HOOD ABOVE FRYER UP TO KEF-2 WITH 12" DIA. PRE-FABRICATED UL 1978 LISTED AND LABELED GREASE DUCT (DRAVENT DIS1 OR EQUAL). PROVIDE TRANSITION ABOVE CEILING TO MATCH HOOD CONNECTION SIZE. CONNECT TO HOOD VIA MANUFACTURER'S UL METHOD FOR GREASE AND SMOKE TIGHT JOINT. INSTALL ACCORDING TO MANUFACTURER'S DIRECTIONS FOR NFPA 96 COMPLIANCE.
- 8 12" GREASE EXHAUST DUCT UP TO KEF-2 ON ROOF. RE: A2/M5.1
- 9 1" CONDENSATE DOWN TO FLOOR. TERMINATE CONDENSATE AT FLOOR DRAIN WITH 1" AIR GAP.
- 10 FULLY INSULATED 1" COPPER CONDENSATE PIPE UP THROUGH ROOF. RE: C4/M5.1. CONDENSATE TO START HORIZONTAL RUN AS CLOSE TO STRUCTURE INSIDE BUILDING AS POSSIBLE.
- 11 THE PILOT RDM SYSTEM CONTROLLER PANEL SHALL BE MOUNTED AND INSTALLED FLUSH IN THE MANAGER'S OFFICE AT 5' AF TO CENTER. COORDINATE FINAL LOCATION OF PANEL WITH OWNER AND GC.
- 12 TEMPERATURE AND HUMIDITY SENSORS "T" AND "H" TO BE CEILING MOUNTED AND TIED INTO THE BUILDING CONTROL SYSTEM.
- 13 LISTED GREASE DUCT ACCESS DOOR ASSEMBLY (DIS1-04DL26 OR EQUAL). INSTALL ON SIDE OF DUCT.
- 14 KITCHEN FREEZER EVAPORATOR UNIT. FURNISHED BY OWNER, INSTALLED BY MC IN COORDINATION WITH GC.
- 15 KITCHEN COOLER EVAPORATOR UNIT. FURNISHED BY OWNER, INSTALLED BY MC IN COORDINATION WITH GC.
- 16 KITCHEN ICEMAKER EVAPORATOR UNIT. FURNISHED BY OWNER, INSTALLED BY MC IN COORDINATION WITH GC.
- 17 MECHANICAL CONTRACTOR TO PROVIDE EQUIPMENT SUPPORTS, REFRIGERANT LINES, AND COMPLETE EQUIPMENT INSTALLATION. COORDINATE EXACT LOCATION OF EQUIPMENT ON-SITE AND ROUTE REFRIGERANT PIPING THROUGH ROOF PENETRATION. COORDINATE PIPING AND UNIT INSTALLATION REQUIREMENTS AND STARTUP WITH KITCHEN EQUIPMENT MANUFACTURER AND GC.
- 18 REMOTE ANSUL SYSTEM MOUNTED ON WALL. CONFIRM FINAL LOCATION OF STATION WITH OWNER, ARCHITECT, AND OTHER TRADES. REFER TO DETAILS AND SPECIFICATIONS.

### MECHANICAL GENERAL NOTES

- A REFER TO M0.1 FOR GENERAL NOTES, SYMBOLS AND ABBREVIATIONS.
- B SMOKE DETECTORS SHALL BE PROVIDED AND INSTALLED BY THE RTU MANUFACTURER IN THE SUPPLY AND RETURN SIDES OF RTU. COORDINATE INSTALLATION AND CONNECTION OF SMOKE DETECTORS WITH FA CONTRACTOR, EC, AND GC. REFERENCE M6.1 FOR RTU SCHEDULE. ACTIVATION OF SMOKE DETECTORS SHALL SHUT DOWN RTU AND ACTIVATE THE AUDIBLE AND VISUAL SIGNAL PROVIDED.
- C PROVIDE NECESSARY ACCESS AND CLEARANCES AROUND ALL EQUIPMENT ACCORDING TO MANUFACTURER'S RECOMMENDATION.
- D MAINTAIN A MINIMUM DISTANCE OF 10'-0" BETWEEN ALL ROOF MOUNTED EQUIPMENT AND EDGE OF ROOF WITH THE EXCEPTION OF EQUIPMENT LOCATED BEHIND AN ARCHITECTURAL GUARD (MINIMUM 42" HIGH) OR PROVIDED WITH AN APPROVED FALL ARREST ANCHORAGE CONNECTOR DEVICE.
- E MAINTAIN A MINIMUM DISTANCE OF 10'-0" BETWEEN MECHANICAL AIR INTAKES AND ALL MECHANICAL EXHAUSTS OR PLUMBING VENTS.
- F AN APPROVED AGENCY SHALL BE HIRED BY THE OWNER AS PART OF THIS PROJECT TO PROVIDE A COMMISSIONING PLAN THAT INCLUDES THE FOLLOWING ITEMS:
- A NARRATIVE DESCRIPTION OF THE ACTIVITIES THAT WILL BE ACCOMPLISHED DURING EACH PHASE OF COMMISSIONING, INCLUDING THE PERSONNEL INTENDED TO ACCOMPLISH EACH OF THE ACTIVITIES.
  - A LISTING OF THE SPECIFIC EQUIPMENT, APPLIANCES OR SYSTEMS TO BE TESTED AND A DESCRIPTION OF THE TESTS TO BE PERFORMED.
  - FUNCTIONS TO BE TESTED INCLUDING, BUT NOT LIMITED TO, CALIBRATIONS AND ECONOMIZER CONTROLS.
  - CONDITIONS UNDER WHICH THE TEST WILL BE PERFORMED. TESTING SHALL AFFIRM WINTER AND SUMMER DESIGN CONDITIONS AND FULL OUTSIDE AIR CONDITIONS.
  - MEASURABLE CRITERIA FOR PERFORMANCE.
- G KITCHEN HOODS, ANSUL FIRE SUPPRESSION SYSTEM AND HOOD CONTROLS SHALL BE OWNER-FURNISHED AND CONTRACTOR-INSTALLED. COORDINATE WITH GC.
- H FINAL LOCATION OF ALL TEMPERATURE AND HUMIDITY SENSORS TO BE COORDINATED IN FIELD. LOCATE SENSORS SUCH THAT THEY ARE ACCESSIBLE, PROTECTED, AND IN AN AREA OF UNOBSTRUCTED AIR CIRCULATION.
- I ALL TESTS AND BALANCES TO BE PERFORMED BY A THIRD PARTY - NOT BY MEP SUBCONTRACTOR.
- J PRIOR TO BEGINNING WORK, COORDINATE COMPLETE INSTALLATION OF ALL ROOFTOP EQUIPMENT AND ACCESSORIES WITH GC AND OTHER TRADES.
- K VERIFY RTU'S ARE LEVEL AND CONDENSATE IS DRAINING PROPERLY.

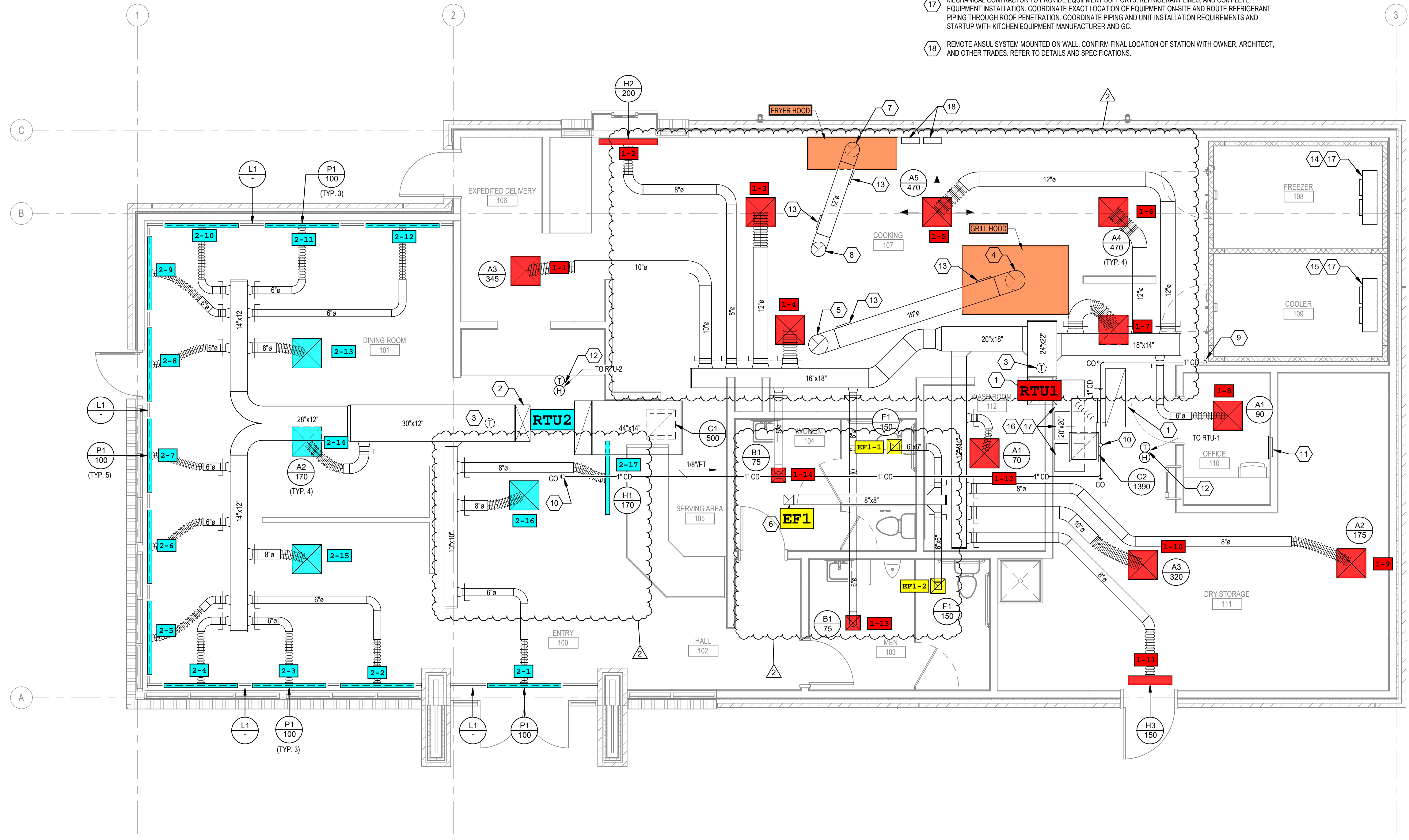

PREPARED FOR:



3420 Torrington Way, Ste 210  
 Charlotte, NC 28227  
 (704) 565-7070  
 (203) 630-2615 Fax

© 2024 BL COMPANIES, INC. THESE DRAWINGS SHALL NOT BE UTILIZED BY ANY PERSON, FIRM OR CORPORATION WITHOUT THE SPECIFIC WRITTEN PERMISSION OF BL COMPANIES.

Date	Description
10/18/2024	PROTOTYPE UPDATE
12/20/2024	OWNER COMMENTS

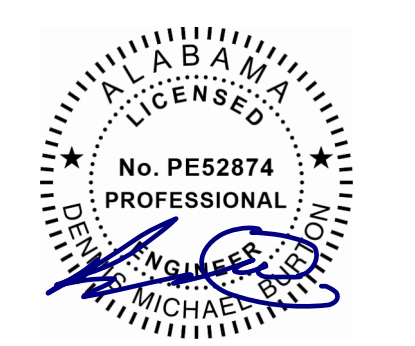

Seal / Signature

Project Name  
**WHATABURGER DAPHNE, AL**

Date: 10.16.2024

Project Number  
**2201817**

Description  
**MECHANICAL FLOOR PLAN**

Scale  
 1/4" = 1'-0" Ref North

**M1.1**

© 2024 BL Companies

**M1** MECHANICAL FLOOR PLAN - LEVEL 1  
 1/4" = 1'-0"

12/20/2024 3:39:27 PM C:\Users\janderson\Documents\201817\_OC\_MECH\_Central\_RZ2\_OC\_panderson\QANC.rvt

### MECHANICAL KEY NOTES

- 1 ROOFTOP HVAC UNIT MOUNTED ON PRE-FABRICATED CURB, RE: C3M5.1
- 2 CENTRIFUGAL UPBLAST GREASE HOOD EXHAUST FAN MOUNTED ON MANUFACTURER PROVIDED ROOF CURB, RE: A2M5.1
- 3 CENTRIFUGAL DOWNBLAST EXHAUST FAN MOUNTED ON MANUFACTURER PROVIDED ROOF CURB, RE: A1M5.1
- 4 REQUIRED UNIT CLEARANCE PER BOB MANUFACTURER. COORDINATE EXACT CLEARANCE REQUIREMENTS WITH INSTALLED EQUIPMENT.
- 5 KITCHEN FREEZER CONDENSING UNIT MOUNTED ON ROOFTOP. FURNISHED BY OWNER, INSTALLED BY MC IN COORDINATION WITH GC. PROVIDE R404A REFRIGERANT, 3/8" LIQUID LINE AND 7/8" SUCTION LINE BETWEEN INDOOR AND OUTDOOR UNIT PER EQUIPMENT MFR.
- 6 KITCHEN COOLER CONDENSING UNIT MOUNTED ON ROOFTOP. FURNISHED BY OWNER, INSTALLED BY MC IN COORDINATION WITH GC. PROVIDE R404A REFRIGERANT, 3/8" LIQUID LINE AND 5/8" SUCTION LINE BETWEEN INDOOR AND OUTDOOR UNIT PER EQUIPMENT MFR.
- 7 KITCHEN ICEMAKER CONDENSING UNIT MOUNTED ON ROOFTOP. FURNISHED BY OWNER, INSTALLED BY MC IN COORDINATION WITH GC. PROVIDE R404A REFRIGERANT, 3/8" LIQUID LINE AND 7/8" SUCTION LINE BETWEEN INDOOR AND OUTDOOR UNIT PER EQUIPMENT MFR.
- 8 MECHANICAL CONTRACTOR TO PROVIDE EQUIPMENT SUPPORTS, REFRIGERANT LINES, AND COMPLETE EQUIPMENT INSTALLATION. COORDINATE EXACT LOCATION OF EQUIPMENT ON-SITE AND ROUTE REFRIGERANT PIPING THROUGH ROOF PENETRATION. COORDINATE PIPING AND UNIT INSTALLATION REQUIREMENTS AND STARTUP WITH KITCHEN EQUIPMENT MANUFACTURER AND GC.
- 9 REFRIGERATION PIPING ROOF PENETRATION, RE: C4M5.1
- 10 ROUTE CONDENSATE LINE DOWN THROUGH ROOF, RE: A1M1.1 FOR CONTINUATION AND RE: C4M5.1 FOR DETAIL.

### MECHANICAL GENERAL NOTES

- A. REFER TO M0.1 FOR GENERAL NOTES, SYMBOLS AND ABBREVIATIONS.
- B. SMOKE DETECTORS SHALL BE PROVIDED AND INSTALLED BY THE RTU MANUFACTURER IN THE SUPPLY AND RETURN SIDES OF RTU. COORDINATE INSTALLATION AND CONNECTION OF SMOKE DETECTORS WITH FA CONTRACTOR, EC, AND GC. REFERENCE M6.1 FOR RTU SCHEDULE. ACTIVATION OF SMOKE DETECTORS SHALL SHUT DOWN RTU AND ACTIVATE THE AUDIBLE AND VISUAL SIGNAL PROVIDED.
- C. PROVIDE NECESSARY ACCESS AND CLEARANCES AROUND ALL EQUIPMENT ACCORDING TO MANUFACTURER'S RECOMMENDATION.
- D. MAINTAIN A MINIMUM DISTANCE OF 10'-0" BETWEEN ALL ROOF MOUNTED EQUIPMENT AND EDGE OF ROOF WITH THE EXCEPTION OF EQUIPMENT LOCATED BEHIND AN ARCHITECTURAL GUARD (MINIMUM 42" HIGH) OR PROVIDED WITH AN APPROVED FALL ARREST ANCHORAGE CONNECTOR DEVICE.
- E. MAINTAIN A MINIMUM DISTANCE OF 10'-0" BETWEEN MECHANICAL AIR INTAKES AND ALL MECHANICAL EXHAUSTS OR PLUMBING VENTS.
- F. AN APPROVED AGENCY SHALL BE HIRED BY THE OWNER AS PART OF THIS PROJECT TO PROVIDE A COMMISSIONING PLAN THAT INCLUDES THE FOLLOWING ITEMS:
  - A NARRATIVE DESCRIPTION OF THE ACTIVITIES THAT WILL BE ACCOMPLISHED DURING EACH PHASE OF COMMISSIONING, INCLUDING THE PERSONNEL INTENDED TO ACCOMPLISH EACH OF THE ACTIVITIES.
  - A LISTING OF THE SPECIFIC EQUIPMENT, APPLIANCES OR SYSTEMS TO BE TESTED AND A DESCRIPTION OF THE TESTS TO BE PERFORMED.
  - FUNCTIONS TO BE TESTED INCLUDING, BUT NOT LIMITED TO, CALIBRATIONS AND ECONOMIZER CONTROLS.
  - CONDITIONS UNDER WHICH THE TEST WILL BE PERFORMED. TESTING SHALL AFFIRM WINTER AND SUMMER DESIGN CONDITIONS AND FULL OUTSIDE AIR CONDITIONS.
  - MEASURABLE CRITERIA FOR PERFORMANCE.
- G. KITCHEN HOODS, ANSUL FIRE SUPPRESSION SYSTEM AND HOOD CONTROLS SHALL BE OWNER-FURNISHED AND CONTRACTOR-INSTALLED. COORDINATE WITH GC.
- H. FINAL LOCATION OF ALL TEMPERATURE AND HUMIDITY SENSORS TO BE COORDINATED IN FIELD. LOCATE SENSORS SUCH THAT THEY ARE ACCESSIBLE, PROTECTED, AND IN AN AREA OF UNOBSTRUCTED AIR CIRCULATION.
- I. ALL TESTS AND BALANCES TO BE PERFORMED BY A THIRD PARTY - NOT BY MEP SUBCONTRACTOR.
- J. PRIOR TO BEGINNING WORK, COORDINATE COMPLETE INSTALLATION OF ALL ROOFTOP EQUIPMENT AND ACCESSORIES WITH GC AND OTHER TRADES.
- K. VERIFY RTU'S ARE LEVEL AND CONDENSATE IS DRAINING PROPERLY.

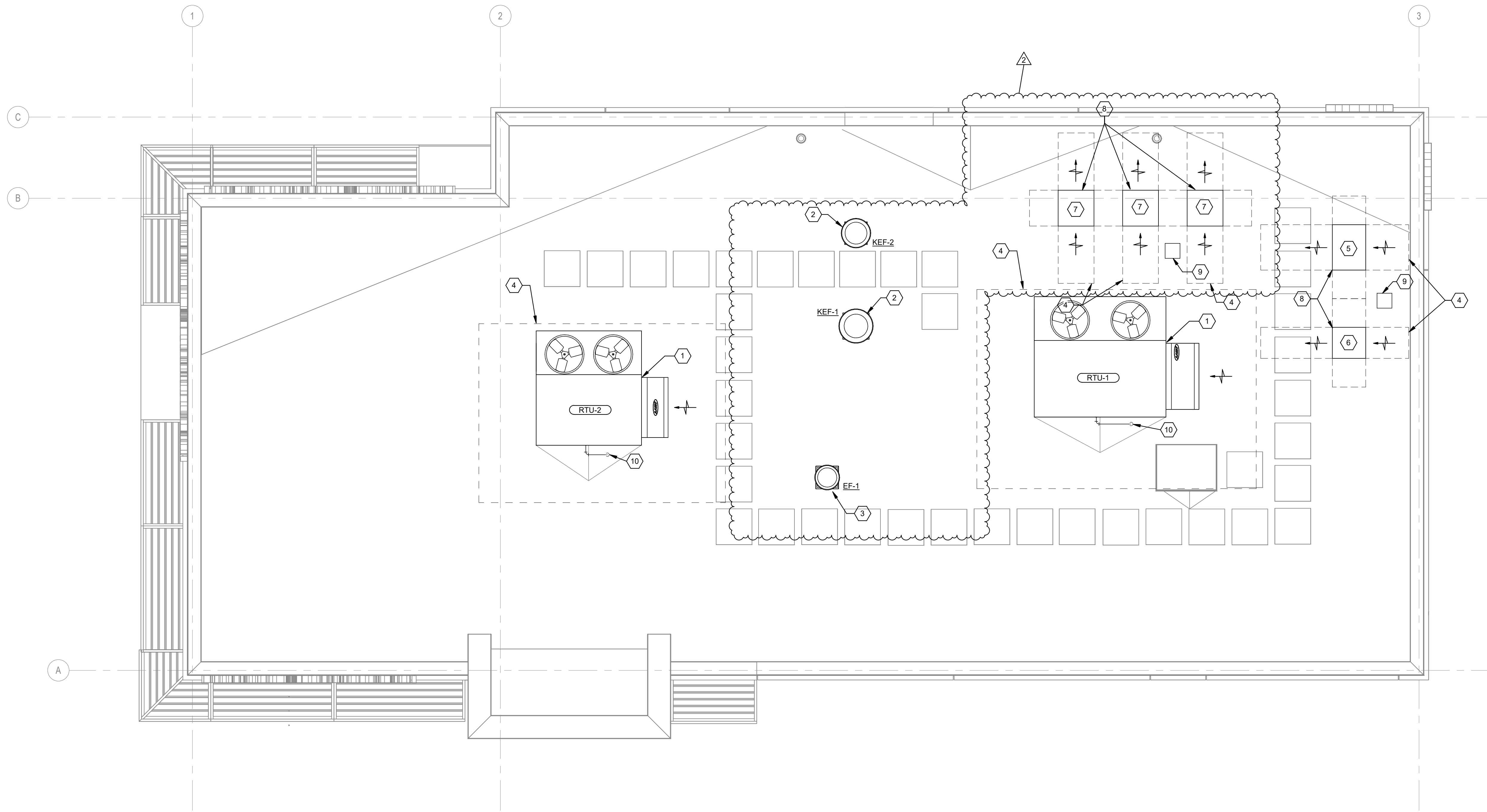

PREPARED FOR:



3420 Torrington Way, Ste 210  
Charlotte, NC 28227  
(704) 565-7070  
(203) 630-2615 Fax

© 2024 BL COMPANIES, INC. THESE DRAWINGS SHALL NOT BE UTILIZED BY ANY PERSON, FIRM OR CORPORATION WITHOUT THE SPECIFIC WRITTEN PERMISSION OF BL COMPANIES.

Date	Description
10/18/2024	PROTOTYPE UPDATE
12/20/2024	OWNER COMMENTS

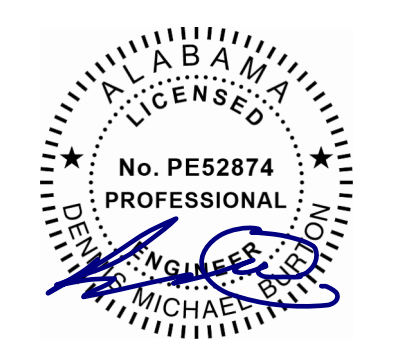

Seal / Signature

Project Name	WHATABURGER DAPHNE, AL
Date:	10.16.2024
Project Number	2201817
Description	MECHANICAL ROOF PLAN

Scale  
1/4" = 1'-0" Ref North

M2.1

© 2024 BL Companies

M1 MECHANICAL ROOF PLAN  
1/4" = 1'-0"

TONS	DRAIN SIZE
UP TO 40	1"
UP TO 90	1-1/4"
UP TO 125	1-1/2"

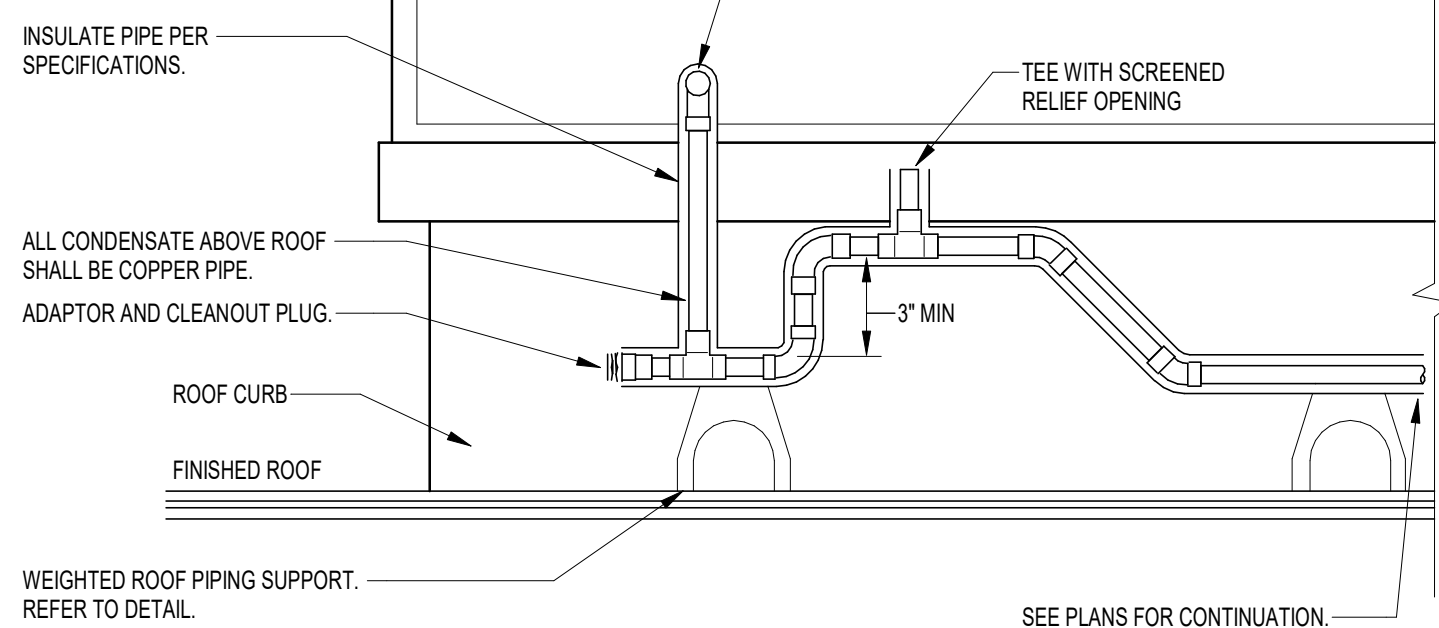

**C1 RTU CONDENSATE DRAIN DETAIL**  
N.T.S.

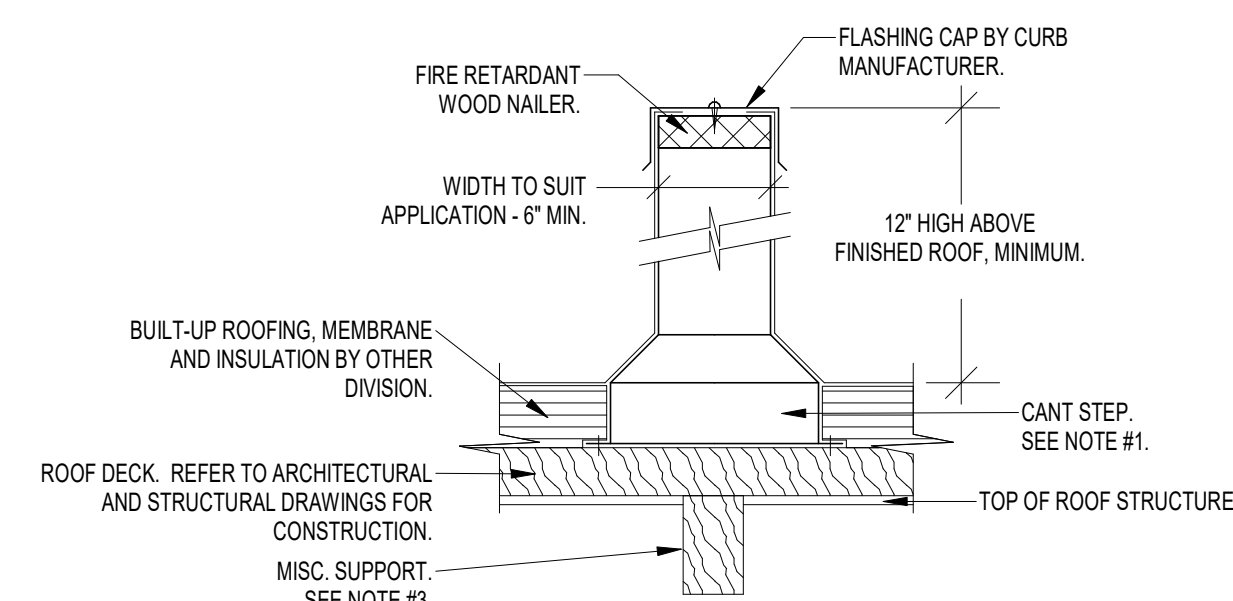

**C3 ROOFTOP HVAC UNIT DETAIL**  
N.T.S.

- NOTES:**
1. THE RAISED CANT STEP HEIGHT SHALL BE COORDINATED WITH THICKNESS OF ROOF INSULATION ON ARCHITECTURAL DRAWINGS AND WITH THE ROOFING CONTRACTOR. SECURE RAIL TO THE ROOF DECK WITH LOAD RATED, RUST RESISTANT FASTENERS.
  2. THE RAIL SHALL BE DESIGNED AND FABRICATED TO THOROUGHLY SUPPORT ITS RESPECTIVE COMPONENT. AS A MINIMUM, RAILS SHALL BE FABRICATED OF 18 GAUGE GALVANIZED STEEL WITH BUILT-IN CANT. MONOLITHIC CONSTRUCTION WITH INTEGRAL BASE PLATE AND CONTINUOUS MITERED AND WELDED CORNER SEAMS, WITH FACTORY INSTALLED FIRE RETARDANT WOOD NAILER. EACH RAIL SHALL INCLUDE A MATCHING 18 GAUGE GALVANIZED STEEL COUNTERFLASHING CAP WITH INTEGRAL DRIP EDGE. ALL CORNERS MITERED AND WELDED, AND SCREWS FOR ATTACHMENT. EQUIPMENT CURBS OVER 3 FEET LONG SHALL INCORPORATE 1/4" GAUGE INTERNAL GUSSET REINFORCING. SECURELY FASTEN TO ROOF DECK AND INSTALL IN STRICT ACCORDANCE WITH MANUFACTURER'S INSTALLATION INSTRUCTIONS. WHEN THE UNIT IS TO BE INSTALLED ON A PITCHED ROOF, COORDINATE WITH THE RAIL MANUFACTURER TO PROVIDE A PITCHED RAIL TO MATCH THE PITCH OF THE ROOF. THE EQUIPMENT/PIPING/DUCTWORK SHALL BE INSTALLED LEVEL AND PLUMB.
  3. THE MECH. CONTRACTOR SHALL COORDINATE THE ORIENTATION OF THE EQUIP. RAILS TO SPAN A MINIMUM OF TWO ROOF BEAMS/JOISTS BELOW. PROVIDE MISC. FRAMING TO CONTINUOUSLY SUPPORT THE RAILS FROM BELOW.
  4. REFER TO THE KITCHEN EQUIPMENT MANUFACTURER'S INSTALLATION INSTRUCTIONS FOR THE MOUNTING REQUIREMENTS TO DETERMINE THE FINAL LOCATION OF THE EQUIPMENT SUPPORT RAILS AND THEIR LENGTH. SECURE EQUIPMENT AS RECOMMENDED BY MANUFACTURER.

**C2 ROOFTOP CONDENSING UNIT SUPPORT RAILS**  
N.T.S.

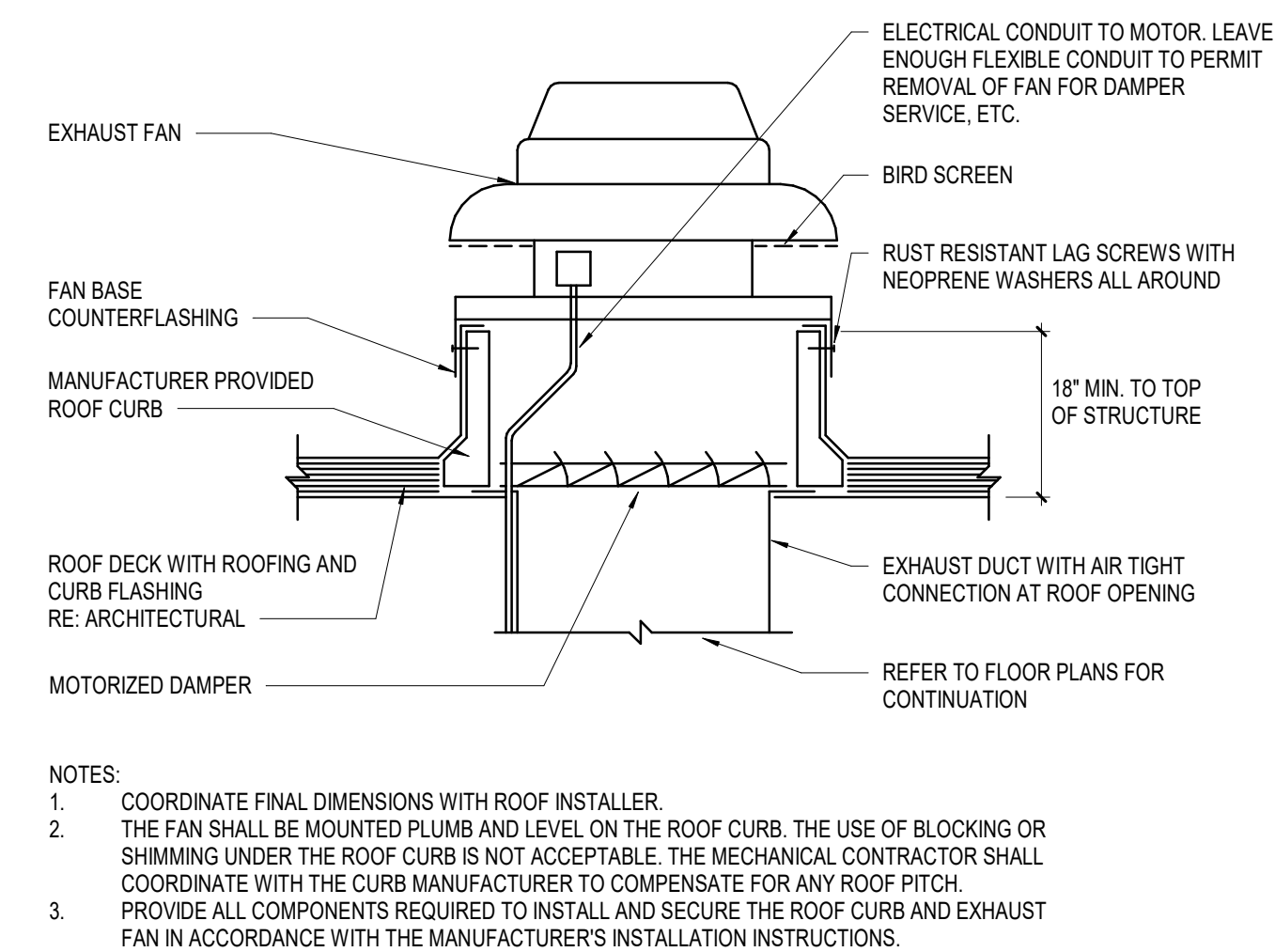

**A1 ROOF MOUNTED EXHAUST FAN AND CURB DETAIL**  
N.T.S.

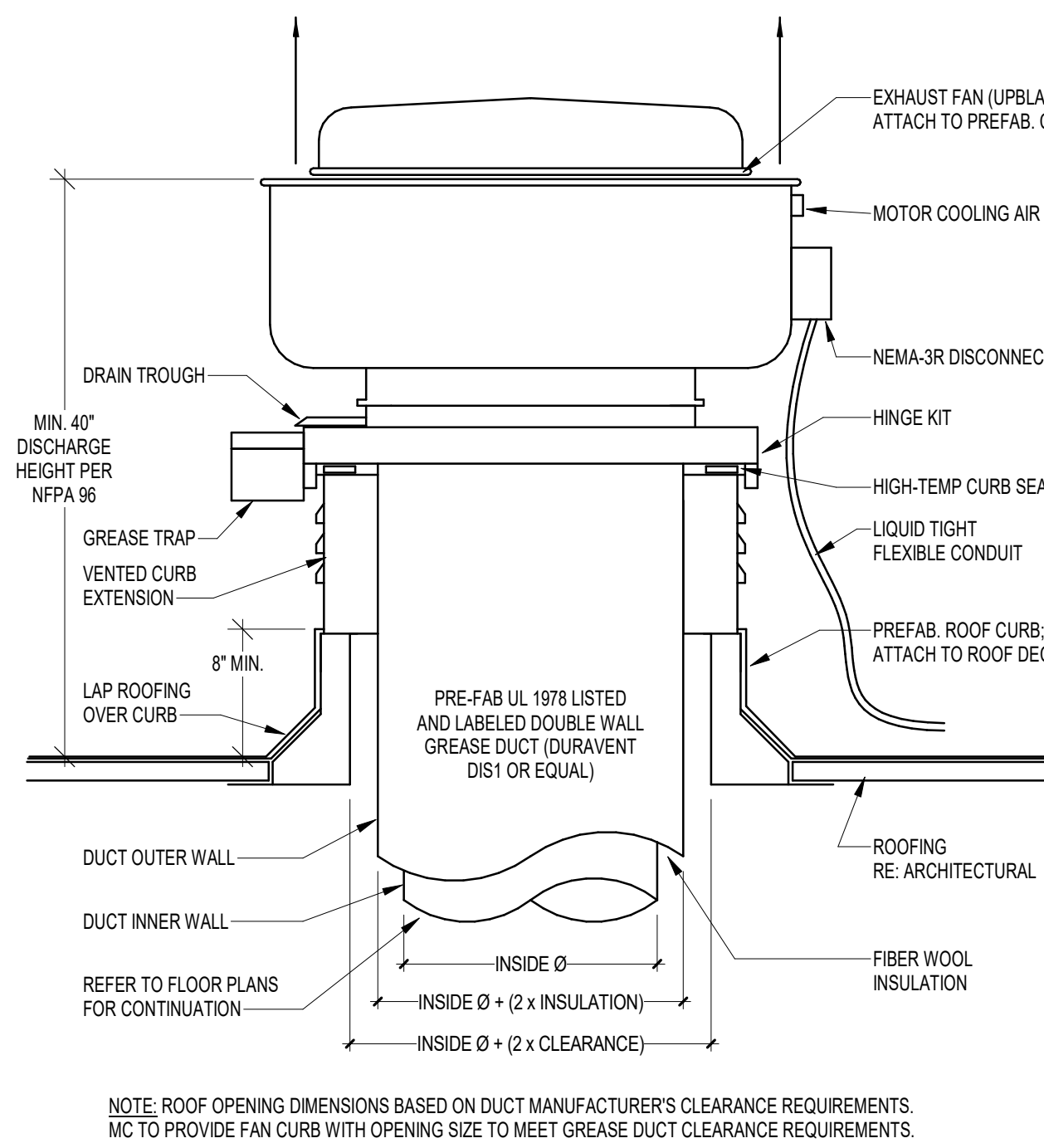

**A2 ROOFTOP GREASE EXHAUST FAN DETAIL**  
N.T.S.

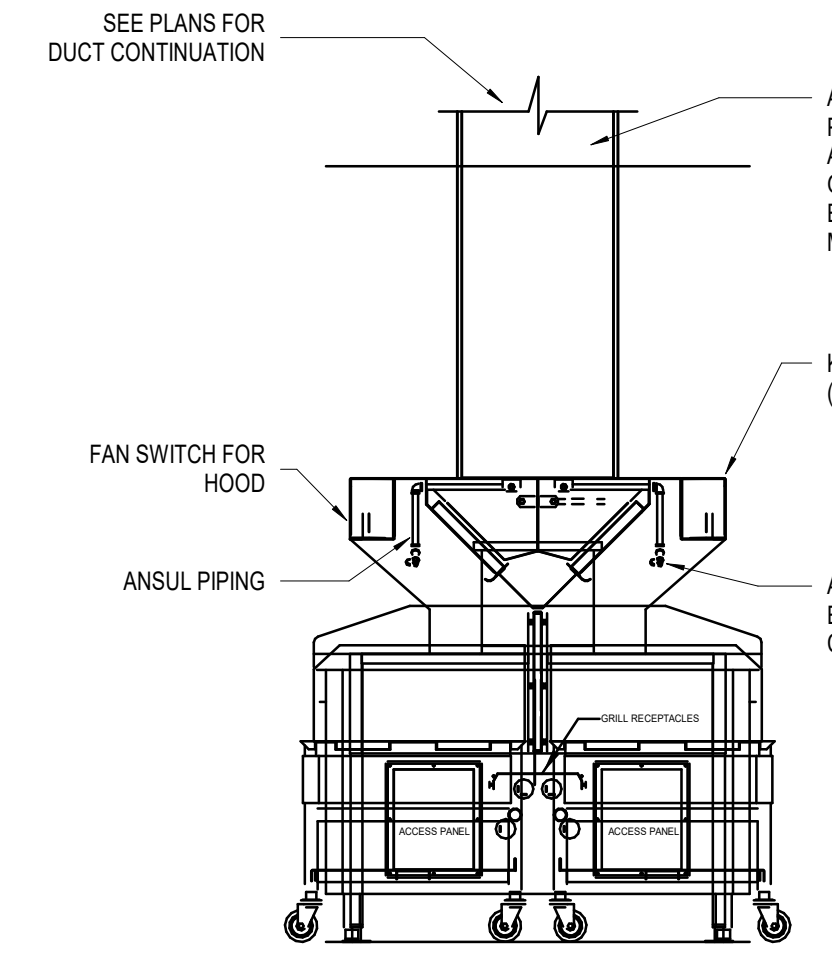

**A3 LOW PROFILE HOOD DETAIL**  
N.T.S.

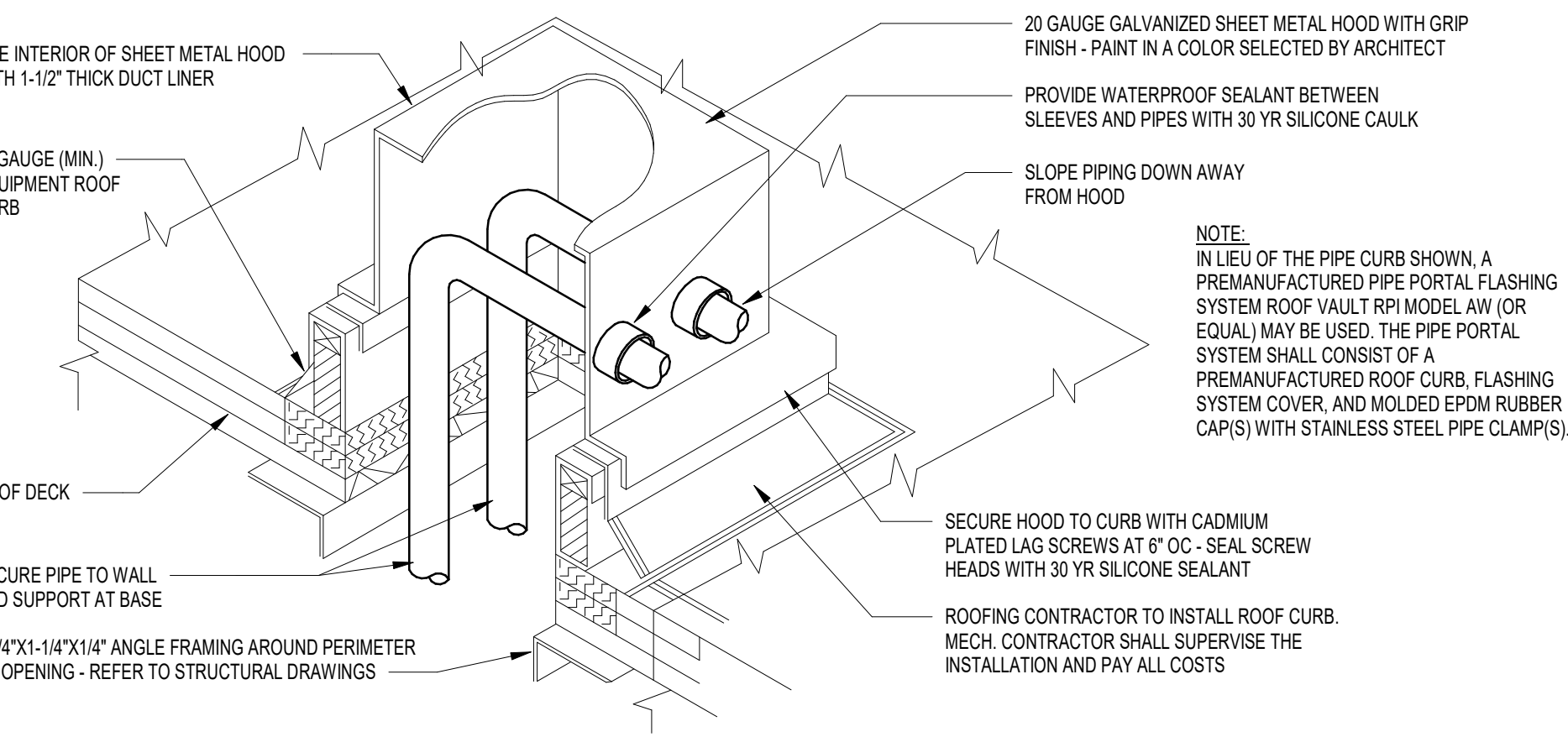

**C4 PIPING THROUGH ROOF DETAIL**  
N.T.S.

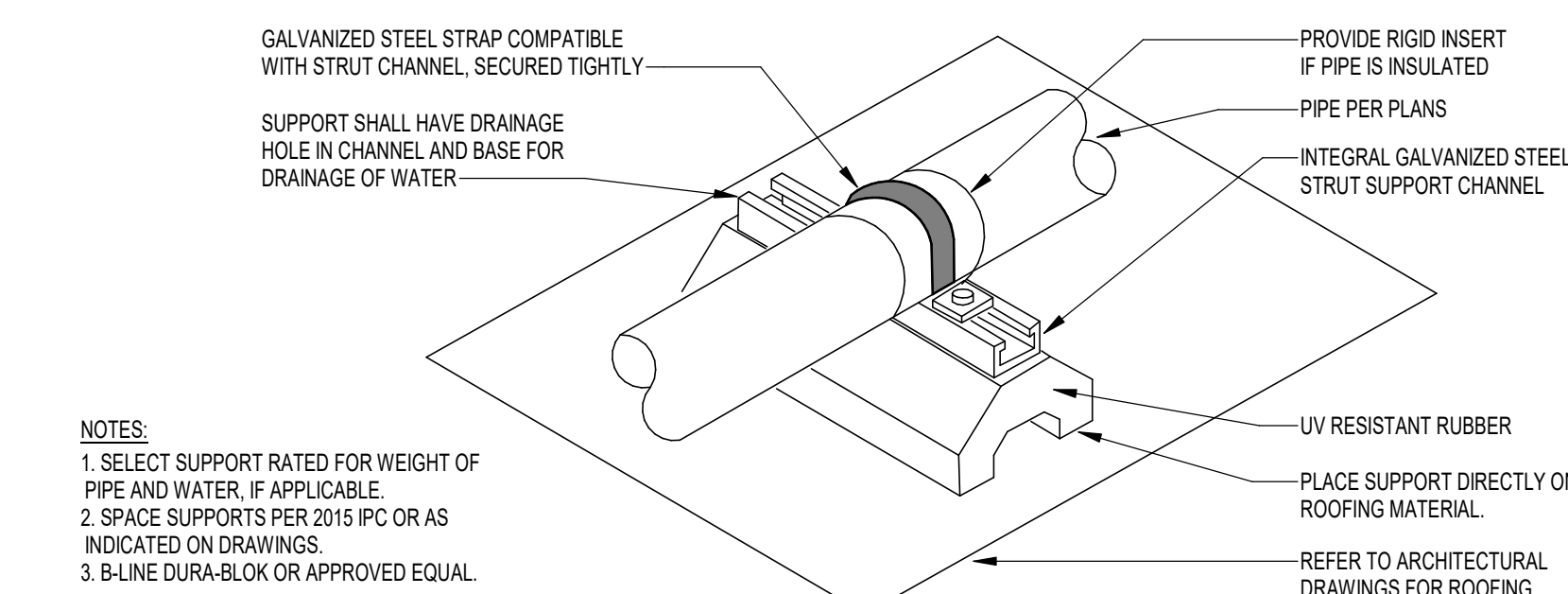

**C5 ROOFTOP PIPE SUPPORT DETAIL**  
N.T.S.

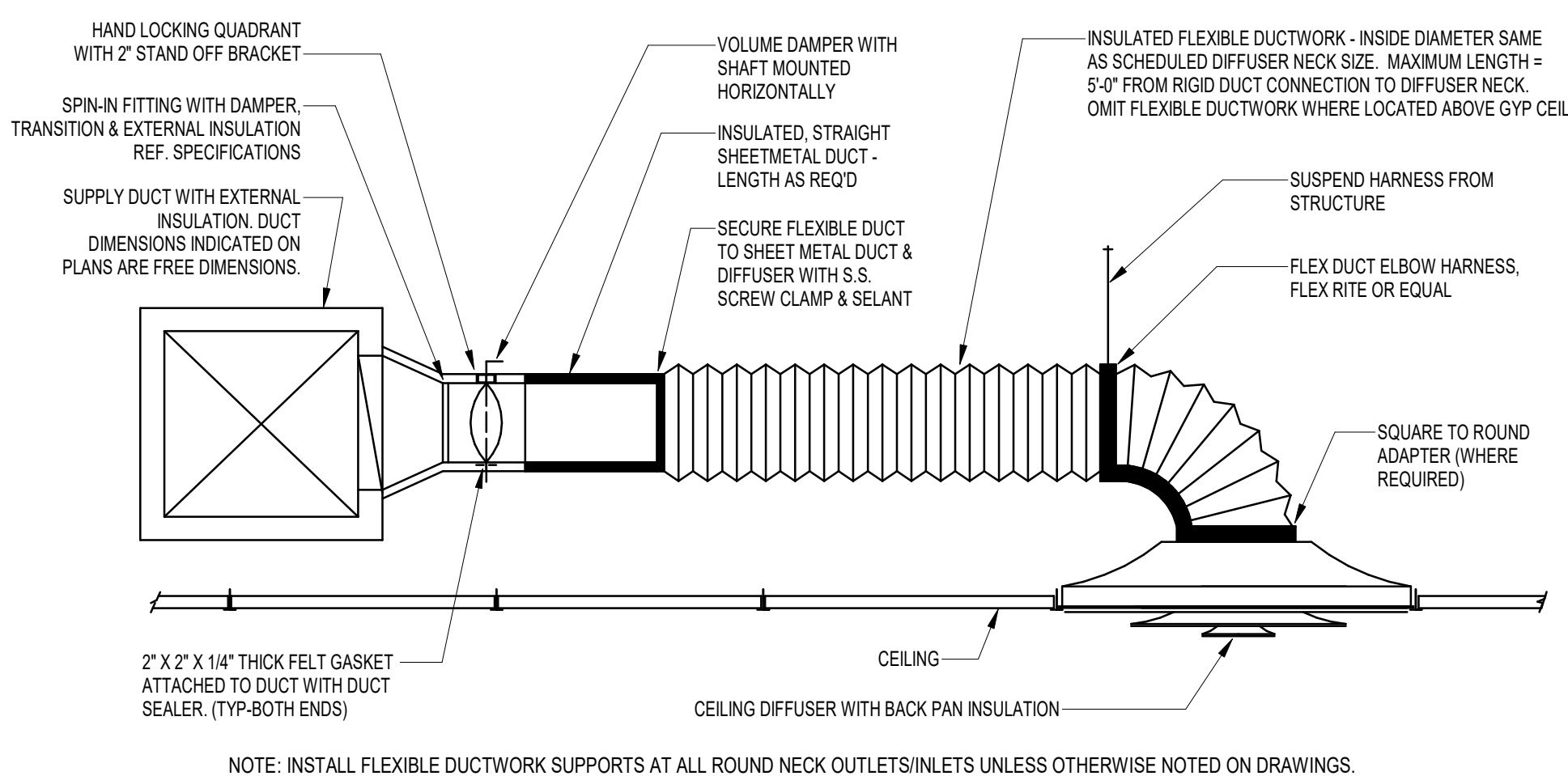

**B2 DIFFUSER CONNECTION DETAIL**  
N.T.S.

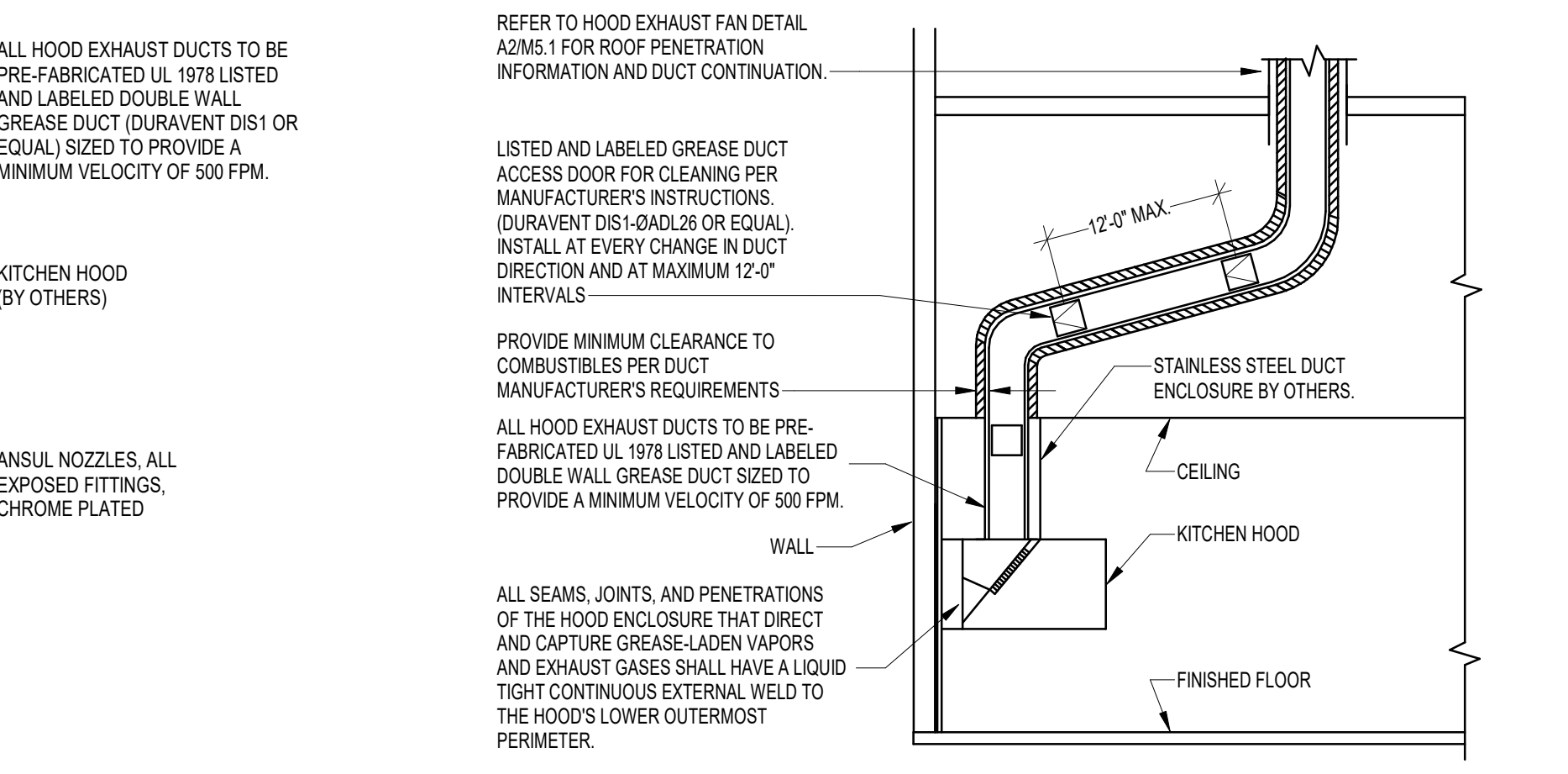

**A4 HOOD EXHAUST DUCT DETAIL**  
N.T.S.



3420 Torrington Way, Ste 210  
Charlotte, NC 28227  
(704) 565-7070  
(203) 630-2615 Fax

© 2024 BL COMPANIES, INC. THESE DRAWINGS SHALL NOT BE UTILIZED BY ANY PERSON, FIRM OR CORPORATION WITHOUT THE SPECIFIC WRITTEN PERMISSION OF BL COMPANIES.

Date	Description
10/18/2024	PROTOTYPE UPDATE



Seal / Signature

Project Name  
WHATABURGER DAPHNE, AL

Date: 10.16.2024

Project Number  
2201817

Description  
MECHANICAL DETAILS

Scale  
NOT TO SCALE

**M5.1**

ROOFTOP UNIT SCHEDULE																																
MARK	MANUFACTURER	MODEL	AREA SERVED	OA CFM	SUPPLY FAN							COOLING SECTION							HEATING SECTION							ELECTRICAL				FILTER TYPE	WEIGHT (LBS)	NOTES
					CFM	ESP (W/G)	RPM	HP	TYPE	REFRIG. TYPE	AMBIENT (°F) DB/WB	TOTAL OUTPUT (MBH)	SENS. OUTPUT (MBH)	MAT (°F) DB/WB	LAT (°F) DB/WB	EER / IEER	HOT GAS REHEAT (MBH)	TYPE	AMBIENT (°F) DB/WB	INPUT (MBH)	OUTPUT (MBH)	STAGES	GAS PRESS. MIN / MAX (W.C.)	MAT (°F) DB/WB	LAT (°F) DB/WB	VOLTS	PH	MCA	MOP			
RTU-1	AAON	RN-020-8-0-GB04-349	KITCHEN	2460	3850	0.75	867	3.0	DX	R-410A	91.980.5	250.43	120.52	85.50/74.96	55.24/54.73	12.1/17.5	71.0	NAT. GAS	26.2/25.0	270.0	218.7	3.1	3.5/10.5	42.0/40.0	94.6/82.4	208	3	99	125	2" MERV 8	2534	ALL
RTU-2	AAON	RN-013-8-0-GB04-3F9	DINING	1550	2050	0.75	1276	2.0	DX	R-410A	91.980.5	160.24	73.30	87.61/76.84	52.71/52.21	11.9/17.6	42.0	NAT. GAS	26.2/25.0	195.0	156.0	3.1	3.5/10.5	36.9/33.0	107.3/64.2	208	3	68	80	2" MERV 8	1960	ALL

- NOTES:
- PROVIDE WITH PREMIUM EFFICIENCY MOTORS IN ACCORDANCE WITH NEMA MG-1.
  - PROVIDE WITH FACTORY INSTALLED SUPPLY AND RETURN SMOKE DETECTORS TO SHUT DOWN UNIT UPON SMOKE DETECTION. COORDINATE CONNECTION TO FIRE ALARM SYSTEM WITH FA CONTRACTOR AND GC.
  - PROVIDE WITH TERMINAL STRIP FOR FIELD INSTALLED CONTROLS.
  - UNITS TO BE 2" DOUBLE WALL R-13 CONSTRUCTION WITH 2500-HOUR SALT SPRAY RESISTANT PAINT.
  - UNIT TO HAVE MODULATING HOT GAS REHEAT AND MODULATE HEAT CONTROL. MECHANICAL CONTRACTOR RESPONSIBLE FOR INSTALLING (2) FACTORY PROVIDED SUPPLY AIR TEMPERATURE SENSORS.
  - PROVIDE FACTORY INSTALLED HAIL GUARDS.
  - PROVIDE 6-ROW DX COIL AND STAINLESS STEEL DRAIN PAN.
  - PROVIDE FACTORY MOUNTED AND WIRED CONDENSATE FLOW SWITCH.
  - PROVIDE ULTRA-LOW LEAKAGE ECONOMIZER WITH BAROMETRIC RELIEF DAMPER, AND FAULT DETECTION AND DIAGNOSTIC.
  - PROVIDE STAINLESS STEEL GAS HEAT EXCHANGER WITH MODULATING CONTROL.
  - PROVIDE FACTORY POWERED GFCI CONVENIENCE OUTLET AND NON-FUSED DISCONNECT.
  - PROVIDE 14" HIGH INSULATED, SOLID BOTTOM CURB FOR PITCHED ROOF. MECHANICAL CONTRACTOR TO FIELD CUT SUPPLY AND RETURN OPENINGS AS REQUIRED.
  - AAON UNITS PROVIDED BY WHATABURGER. FACTORY STARTUP IS INCLUDED. CONTACT AARON HUMPHRIES @ 210-954-6657 OR aaron.humphries@texasairsystems.com TO COORDINATE STARTUP.

FLEX DUCT SCHEDULE	
CFM RANGE	SIZE (DIAMETER)
< 50	5
51 - 100	6
101 - 250	8
251 - 400	10
401 - 650	12
651 - 900	14
901 - 1300	16
1301 - 1800	18
1800 - 2300	20

NOTES:

- ALL FLEX DUCT SHALL BE SIZED IN ACCORDANCE WITH FLEX DUCT SCHEDULE. PROVIDE RIGID REDUCER AT NECK OF AIR DEVICE TO TRANSITION FROM FLEX DUCT SIZE TO DIFFUSER INLET CONNECTION SIZE. FLEX DUCT LENGTH NOT TO EXCEED 5 FT.

EXHAUST FAN SCHEDULE													
MARK	MANUFACTURER	MODEL	TYPE	AIRFLOW (CFM)	TSP (W/G)	RPM	BHP	HP	DRIVE TYPE	VOLTS	PH	WEIGHT (LBS.)	NOTES
EF-1	GREENHECK	G-080-VG	ROOF-MOUNTED CENTRIFUGAL DOWNBLAST	300	0.50	1680	0.07	0.10	DIRECT	120	1	44	1,2,3
KEF-1	GREENHECK	CLUE-140-VG	ROOF-MOUNTED CENTRIFUGAL UPBLAST	1994	1.00	1517	0.64	1.00	DIRECT	208	1	148	3,4,5,6
KEF-2	GREENHECK	CLUE-120-VG	ROOF-MOUNTED CENTRIFUGAL UPBLAST	1216	0.75	1415	0.25	0.50	DIRECT	208	1	115	3,4,5,6

NOTES:

- PROVIDE INSULATED 18" HIGH ROOF CURB WITH DAMPER TRAY AND MOTORIZED DAMPER WITH END SWITCHES AND SPRING RETURN ACTUATOR.
- PROVIDE ALUMINUM BIRD SCREEN.
- PROVIDE WITH INTEGRAL DISCONNECT SWITCH NEMA-3R.
- PROVIDE GREASE BOX.
- PROVIDE INSULATED AND VENTED 24" HIGH ROOF CURB AND HIGH TEMPERATURE CURB SEAL.
- PROVIDE HINGED ACCESS KIT.

AIR DEVICE SCHEDULE													
MARK	MANUFACTURER	MODEL	FACE SIZE (IN.)	NECK SIZE (IN.)	MAX NC	PATTERN	MOUNTING	SLOT LENGTH	SLOT WIDTH	SLOT QTY	SYSTEM CLASS	COMMENTS	
A1	TITUS	TMS	24x24	6	30	4-WAY	LAY-IN	-	-	-	SUPPLY AIR	1	
A2	TITUS	TMS	24x24	8	30	4-WAY	LAY-IN	-	-	-	SUPPLY AIR	1	
A3	TITUS	TMS	24x24	10	30	4-WAY	LAY-IN	-	-	-	SUPPLY AIR	1	
A4	TITUS	TMS	24x24	12	30	4-WAY	LAY-IN	-	-	-	SUPPLY AIR	1	
A5	TITUS	TMS	24x24	12	30	3-WAY	LAY-IN	-	-	-	SUPPLY AIR	1	
B1	TITUS	TMS	12x12	6	30	4-WAY	FLANGE	-	-	-	SUPPLY AIR	1,2	
C1	TITUS	350FLF1	22x22	18x18	30	-	FLANGE	-	-	-	RETURN AIR	2,5	
C2	TITUS	350FLF1	24x24	20x20	30	-	LAY-IN	-	-	-	RETURN AIR	5	
F1	TITUS	50F	18x18	6x6	30	-	FLANGE	-	-	-	EXHAUST AIR	2	
H1	TITUS	TBDI-30	60x3-12	8	30	2-WAY	FLANGE	60	3/4	2	SUPPLY AIR	3	
H2	TITUS	TBDI-80	36x7-12	8	30	2-WAY	FLANGE	36	1-1/2	3	SUPPLY AIR	3	
H3	TITUS	TBDI-80	36x7-12	8	30	2-WAY	FLANGE	36	1-1/2	3	SUPPLY AIR	3	
L1	TITUS	FL-15-JT	SEE PLANS	-	30	1-WAY	FLANGE	CONTINUOUS	1-1/2	1	SUPPLY AIR	4	
P1	TITUS	FBPI	60 X 3-1/2	6	30	-	FLANGE	60	-	-	SUPPLY AIR	3	

NOTES:

- PROVIDE MOLDED INSULATION BLANKET (R-6).
- PROVIDE PLASTER FRAME FOR MOUNTING IN GYP. CEILING.
- PROVIDE INSULATED PLENUM.
- CONTINUOUS LINEAR SLOT DIFFUSER TO BE INSTALLED IN GYP. CEILING. PROVIDE INSULATED SUPPLY AIR PLENUMS AS SCHEDULED FOR A COMPLETE SYSTEM.
- PROVIDE 1" MERV-5 FILTER.

**COMcheck Software Version 4.1.5.1**

## Mechanical Compliance Certificate

**Project Information**

Energy Code: 2015 IECC  
 Project Title: Whataburger  
 Location: Daphne, Alabama  
 Climate Zone: 2a  
 Project Type: New Construction

Construction Site: U.S. HIGHWAY 98 / LAVENDER LANE, DAPHNE, AL  
 Owner/Agent: Whataburger  
 Designer/Contractor: BL Companies, Inc., 355 Research Parkway, Meriden, CT 06450

**Additional Efficiency Package(s)**

Reduced interior lighting power. Requirements are implicitly enforced within interior lighting allowance calculations.

**Mechanical Systems List**

**Quantity System Type & Description**

1 RTU-1 (Single Zone):  
 Heating: 1 each - Central Furnace, Gas, Capacity = 270 kBtu/h  
 Proposed Efficiency = 81.00% Et, Required Efficiency: 80.00 % Et  
 Cooling: 1 each - Single Package DX Unit, Capacity = 250 kBtu/h, Air-Cooled Condenser, Air Economizer  
 Proposed Efficiency = 12.10 EER, Required Efficiency: 9.80 EER + 11.4 IEER  
 Fan System: FAN SYSTEM 1 | RTU-1 -- Compliance (Motor nameplate HP method) : Passes

Fans:  
 FAN 1 Supply, Constant Volume, 3850 CFM, 3.0 motor nameplate hp

1 RTU-2 (Single Zone):  
 Heating: 1 each - Central Furnace, Gas, Capacity = 195 kBtu/h  
 Proposed Efficiency = 80.00% Et, Required Efficiency: 80.00 % Et or 78% AFUE  
 Cooling: 1 each - Single Package DX Unit, Capacity = 160 kBtu/h, Air-Cooled Condenser, Air Economizer  
 Proposed Efficiency = 11.90 EER, Required Efficiency: 10.80 EER + 12.2 IEER  
 Fan System: FAN SYSTEM 2 | RTU-2 -- Compliance (Motor nameplate HP method) : Passes

Fans:  
 FAN 2 Supply, Constant Volume, 2050 CFM, 2.0 motor nameplate hp

1 GWH-1:  
 Gas Storage Water Heater, Capacity: 50 gallons, Input Rating: 100 kBtu/h w/ Circulation Pump  
 Proposed Efficiency: 96.00 % Et, Required Efficiency: 80.00 % Et

**Mechanical Compliance Statement**

Compliance Statement: The proposed mechanical design represented in this document is consistent with the building plans, specifications, and other calculations submitted with this permit application. The proposed mechanical systems have been designed to meet the 2015 IECC requirements in COMcheck Version 4.1.5.1, and to comply with any applicable mandatory requirements listed in the Inspection Checklist.

Philip Anderson - Project Engineer      *Philip Anderson*      12/20/2024  
 Name - Title      Signature      Date

Project Title: Whataburger      Report date: 12/20/24  
 Data file name: G:\JOBS\231812301817\DOCS\Comcheck\0-2024-10-10-Q2 2024\PROTO\2301819-Comcheck W DAPHNE, AL.cck

### AIR BALANCE AND VENTILATION CALCULATION:

TOTAL OUTSIDE AIR INTAKE = 4010 CFM  
 TOTAL GREASE HOOD EXHAUST = 3210 CFM  
 TOTAL RESTROOM EXHAUST = 300 CFM

OUTSIDE AIRFLOW - (GREASE HOOD EXHAUST AIRFLOW + RESTROOM EXHAUST AIRFLOW) = NET POSITIVE AIRFLOW

4010 CFM - (3210 + 300) = 500 CFM

BALANCE REPORT TO BE PROVIDED TO INSPECTOR, OWNER, AND ARCHITECT/ENGINEER FOR REVIEW AND APPROVAL.

**VENTILATION CALCULATION PER IMC 2021, TABLE 403.3.1.1:**

HVAC UNIT	AREA SERVED	CLASSIFICATION	OCCUPANT LOAD	REQUIRED VENTILATION	O.A./E.A. REQUIRED (CFM)	O.A./E.A. DESIGN (CFM)	REMARKS
RTU-1	EXPEDITED DELIVERY 106	KITCHENS (COOKING)	2 (73 SQFT)	7.5 CFM / PERSON 0.12 CFM / SQFT	24	220	
	COOKING 107	KITCHENS (COOKING)	15 (745 SQFT)	7.5 CFM / PERSON 0.12 CFM / SQFT	202	1629	
	OFFICE 110	OFFICE SPACES	1 (53 SQFT)	5 CFM / PERSON 0.06 CFM / SQFT	8	58	
	DRY STORAGE 111	STORAGE ROOMS	0 (458 SQFT)	0 CFM / PERSON 0.12 CFM / SQFT	55	412	
	WASH ROOM 112	KITCHENS (COOKING)	2 (83 SQFT)	7.5 CFM / PERSON 0.12 CFM / SQFT	26	45	
	MEN 103 / WOMEN 104	TOILET ROOMS	0 (216 SQFT)	0 CFM / PERSON 0 CFM / SQFT	0	96	
CALCULATED OUTSIDE AIR FOR SYSTEM TOTAL					315	2460	OA ADDED FOR KITCHEN EXHAUST MAKEUP
RTU-2	ENTRY 100 / HALL 102	CORRIDOR	0 (147 SQFT)	0 CFM / PERSON 0.06 CFM / SQFT	9	76	
	DINING ROOM 101	CAFETERIA, FAST FOOD	88 (882 SQFT)	7.5 CFM / PERSON 0.18 CFM / SQFT	819	1346	
	SERVING AREA 105	RECEPTION AREAS	3 (94 SQFT)	5 CFM / PERSON 0.06 CFM / SQFT	21	128	
CALCULATED OUTSIDE AIR FOR SYSTEM TOTAL					849	1550	OA ADDED FOR KITCHEN EXHAUST MAKEUP
EF-1	MEN 103	TOILET ROOMS (INTERMITTENT)	2 W.C.	70 CFM / W.C.	140	150	
	WOMEN 104	TOILET ROOMS (INTERMITTENT)	2 W.C.	70 CFM / W.C.	140	150	
CALCULATED EXHAUST AIR FOR SYSTEM TOTAL					280	300	
KEF-1, KEF-2	TOTAL KITCHEN AREAS	KITCHENS (COOKING)	911 SQFT	0.7 CFM / SQFT	638	3210	
	CALCULATED EXHAUST AIR FOR SYSTEM TOTAL					638	3210

PREPARED FOR:



**Whataburger**

---



**Architecture  
Engineering  
Environmental  
Land Surveying  
Companies**

3420 Torrington Way, Ste 210  
 Charlotte, NC 28227  
 (704) 565-7070  
 (203) 630-2615 Fax

© 2024 BL COMPANIES, INC. THESE DRAWINGS SHALL NOT BE UTILIZED BY ANY PERSON, FIRM OR CORPORATION WITHOUT THE SPECIFIC WRITTEN PERMISSION OF BL COMPANIES.

Date	Description
10/18/2024	PROTOTYPE UPDATE
12/20/2024	OWNER COMMENTS

Seal / Signature

Project Name  
**WHATABURGER DAPHNE, AL**

Date: 10.16.2024











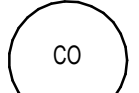



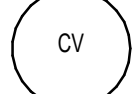

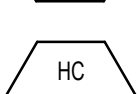

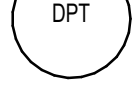

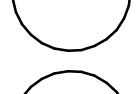
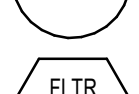
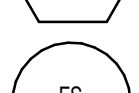
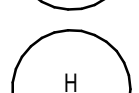

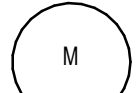

Project Number  
**2201817**

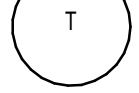
Description  
**MECHANICAL SCHEDULES**

Scale  
**NOT TO SCALE**

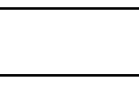
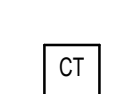
**M6.1**

# CONTROL SYMBOLS

AE	ANALYZER ELEMENT		CARBON MONOXIDE SENSOR
DDC	DIRECT DIGITAL CONTROL		HIGH STATIC PRESSURE SENSOR
BMS	BUILDING MANAGEMENT SYSTEM		DAMPER ACTUATOR
RDC	ROOFTOP UNIT DDC CONTROLLER		CONTROL VALVE
FACP	FIRE ALARM CONTROL PANEL		DX COOLING COIL
	DIFFERENTIAL PRESSURE INDICATOR		NATURAL GAS HEATING COIL
	DIFFERENTIAL PRESSURE SWITCH		HOT GAS REHEAT
	DIFFERENTIAL PRESSURE TRANSMITTER		SUPPLY AIR FAN
	ELECTRIC DUCT HEATER		
	EXHAUST FAN		
	FLOW ELEMENT		
	FILTER		
	FLOW SWITCH		
	HUMIDISTAT		
	HIGH TEMPERATURE LIMIT SWITCH		
	MOTOR		
	PRESSURE CONTROL VALVE		
	PRESSURE TRANSMITTER		
	SMOKE DETECTOR		
	TEMPERATURE SENSOR		
	TEMPERATURE CONTROL VALVE		
	LOW LIMIT THERMOSTAT (FREEZE/STAT)		
	TEMPERATURE TRANSMITTER		
	VARIABLE FREQUENCY DRIVE		
	MOTOR STARTER (PROVIDE CONTROL RELAY)		
	CURRENT TRANSDUCER		
	OCCUPANCY SENSOR		

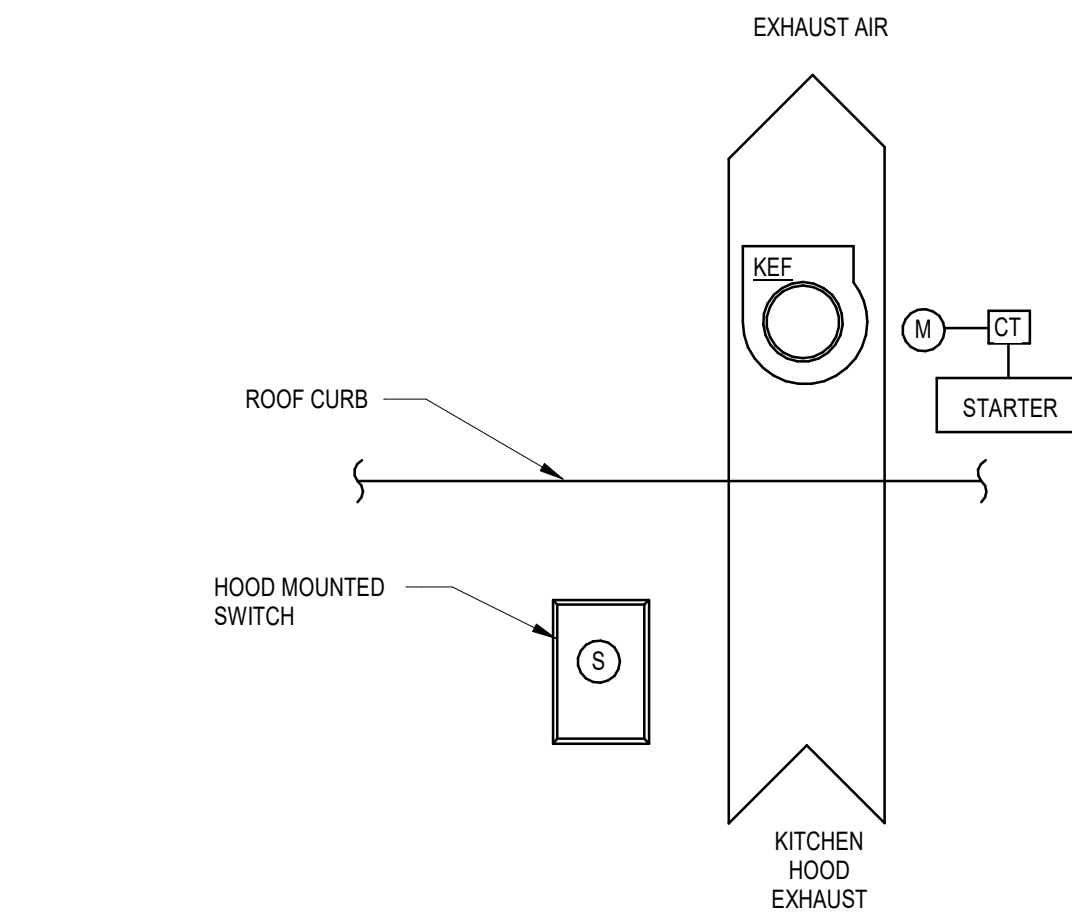

## SEQUENCE OF OPERATION

**OPERATING CONDITIONS - CONTINUOUS 24/7:**  
THE KITCHEN HOOD EXHAUST FAN SHALL RUN CONTINUOUSLY WHEN THE KITCHEN HOOD MOUNTED SWITCH IS ON.

**INTEGRATED ANSUL FIRE SUPPRESSION SYSTEM:**  
UPON ACTIVATION OF THE INTEGRATED ANSUL FIRE SUPPRESSION SYSTEM DURING NORMAL KITCHEN OPERATION, THE KITCHEN HOOD EXHAUST FAN SHALL REMAIN ENERGIZED.

**FIRE/SMOKE CONTROL:**  
UPON SENSING DUCT SMOKE, THE KITCHEN EXHAUST FAN SHALL BE CYCLED OFF. FAN STATUS SHALL BE REPORTED TO THE BAS.

**B1** KITCHEN HOOD EXHAUST FAN CONTROL DIAGRAM  
N.T.S.

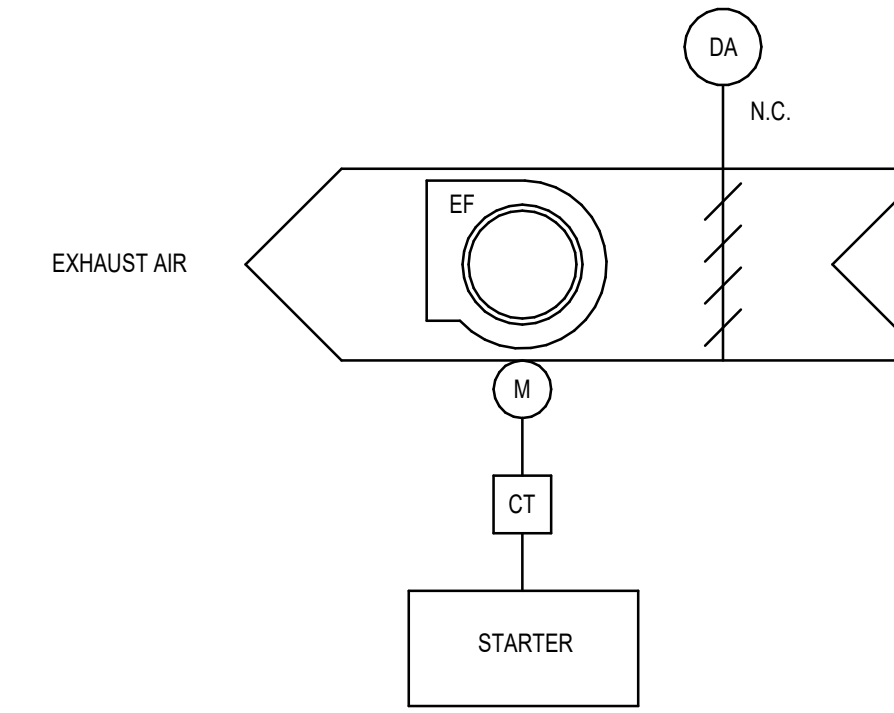

## SEQUENCE OF OPERATION

**OPERATING CONDITIONS:**  
THE GENERAL EXHAUST FAN SHALL BE INTERLOCKED WITH THE RESTROOM OCCUPANCY SENSORS. THE EXHAUST FAN SHUTOFF DAMPER SHALL BE INTERLOCKED WITH THE EXHAUST FAN TO OPEN WHEN THE FAN IS ENERGIZED AND CLOSE WHEN THE FAN IS DE-ENERGIZED.

**ALARMS:**  
ALARMS SHALL BE PROVIDED AS FOLLOWS:  
1. FAN FAILURE: FAN COMMANDED ON BUT STATUS IS OFF.  
2. FAN IN HAND: FAN COMMANDED OFF BUT STATUS IS ON.  
3. FAN BELT FAILURE: MOTOR AMPERAGE READS ZERO AS MEASURED BY CURRENT TRANSDUCER.

**B2** GENERAL EXHAUST FAN CONTROL DIAGRAM  
N.T.S.

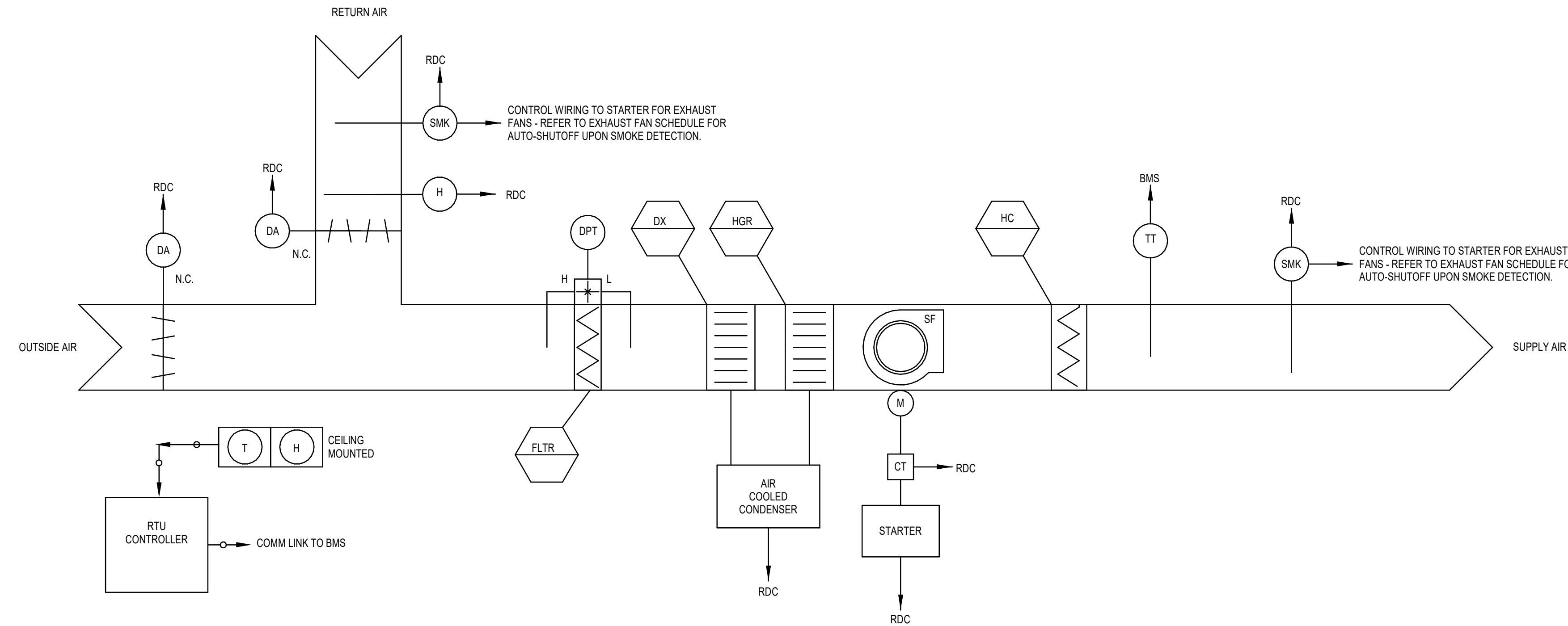

## SEQUENCE OF OPERATION

**OPERATING CONDITION - CONTINUOUS 24/7**

THE PILOT RTU CONTROLLER (RDC) SHALL PERFORM ALL CONTROL, SAFETY AND INTERLOCKS AS DESCRIBED IN THE SEQUENCE OF OPERATION. THE BMS SHALL MONITOR THE RTU DDC CONTROLLER VIA BMS PROTOCOL COMMUNICATION AND/OR COMBINATION OF DISCRETE INPUT/OUTPUT POINTS. THE BMS SHALL OPERATE THE UNIT CONTINUOUS 24/7. WHEN THE UNIT IS DE-ENERGIZED BY THE BMS, THE FAN SHALL SHUT DOWN, THE OA DAMPER SHALL CLOSE, THE REFRIGERATION SYSTEM SHALL ALSO BE DE-ENERGIZED AND THE HEATING SYSTEM LOCKED OUT OF HEATING MODE.

THE BMS SHALL BE PROGRAMMED SO THAT THE HEATING AND COOLING SYSTEMS SHALL NEVER OPERATE SIMULTANEOUSLY.

**TEMPERATURE CONTROL**

OCCUPIED MODE - THE BMS WILL MAINTAIN THE FOLLOWING SPACE TEMPERATURE SETPOINTS:

- COOLING: 75°F, 55% RH (ADJUSTABLE)
- HEATING: 70°F (ADJUSTABLE)

SETBACK MODE - THE BMS WILL MAINTAIN THE FOLLOWING SPACE TEMPERATURE SETPOINTS:

- COOLING: 85°F (ADJUSTABLE) (ADJUST TO 80°F 1-HR PRIOR TO OCCUPANCY)
- HEATING: 60°F (ADJUSTABLE) (ADJUST TO 65°F 1-HR PRIOR TO OCCUPANCY)

THERE SHALL BE A DEADBAND OF +/- 5°F ON ALL TEMPERATURE CONTROL.

**HUMIDITY CONTROL**

IF THE RELATIVE HUMIDITY OF THE RETURN AIR EXCEEDS 80% (ADJUSTABLE) AND THERE IS NO CALL FOR COOLING IN THE SPACE, THE RDC SHALL ENABLE DEHUMIDIFICATION MODE OF THE RTU BASED ON ITS OWN INTERNAL CONTROLS UTILIZING HOT GAS REHEAT.

## SEQUENCE OF OPERATION [CONTINUED]

**ECONOMIZER OPERATION**

BASED ON THE RTU INTERNAL DIFFERENTIAL ENTHALPY CONTROLS, THE RDC SHALL VARY THE OUTSIDE AIR DAMPER POSITION, BASED ON CALL FOR COOLING IN THE SPACE. THERE SHALL BE ONE FAN SPEED. THE RDC SHALL LOAD AND UNLOAD COMPRESSORS BASED ON THE UNIT INTERNAL CONTROLS TO CONDITION OR DEHUMIDIFY THE SPACE AS NEEDED.

**UNIT SHUTDOWN**

UNIT SHALL BE DE-ENERGIZED UPON DETECTION OF SMOKE IN UNIT OR BUILDING FIRE ALARM.

**ALARMS**

THE BMS SHALL MONITOR ALL SAFETIES ON THE REFRIGERATION SYSTEM AND THE HEATING SYSTEM THROUGH THE RDC COMMUNICATION PROTOCOL. ALL ABNORMAL CONDITIONS SHALL BE ALARMED AT THE BMS.

A. **FILTERS:**  
THE RDC SHALL MONITOR THE STATIC PRESSURE DROP ACROSS THE FILTER BANK AND ALARM ON HIGH STATIC PRESSURE DROP. A DIFFERENTIAL PRESSURE SWITCH ACROSS THE FILTER SHALL INITIATE FILTER ALARM WHEN THE PRESSURE DROP ACROSS THE FILTER REACHES THE SETPOINT OF 1.0 INCHES W.C. (ADJUSTABLE).

B. **FIRE/SMOKE CONTROL:**  
UPON ACTIVATION OF A DUCT SMOKE DETECTOR, THE BMS SHALL RECEIVE AN ALARM.

C. **GENERAL ALARM:**  
ANY TROUBLE ALARM OR FAULT WITHIN THE UNIT ONBOARD CONTROLS WILL GENERATE A GENERAL ALARM TO THE BMS.

**A1** PACKAGED ROOFTOP UNIT CONTROLS DIAGRAM  
N.T.S.

PREPARED FOR:



3420 Torrington Way, Ste 210  
Charlotte, NC 28227  
(704) 565-7070  
(203) 630-2615 Fax

© 2024 BL COMPANIES, INC. THESE DRAWINGS SHALL NOT BE UTILIZED BY ANY PERSON, FIRM OR CORPORATION WITHOUT THE SPECIFIC WRITTEN PERMISSION OF BL COMPANIES.

Date	Description
10/18/2024	PROTOTYPE UPDATE



Seal / Signature

Project Name  
WHATABURGER DAPHNE, AL

Date: 10.16.2024

Project Number  
2201817

Description  
MECHANICAL CONTROLS

Scale  
NOT TO SCALE

M7.1



**TOP VIEW**  
 -1105 [43 1/2]  
 -1045 [41 5/32]  
 -292 [11 1/2]  
 -1413 [55 9/16]  
 -4409 [10 5/8]

**FRONT VIEW**  
 -760 [29 29/32]  
 -2743 [108]  
 -1016 [40]  
 -2124 [83 5/8] I.D.  
 -2204 [86 25/32]

**RIGHT VIEW**  
 -689 [27 1/8]  
 -761 [29 15/16]  
 -34 [1 11/32]  
 -762 [30 1/32]  
 -915 [36]  
 -596 [23 15/32]  
 -1343 [52 7/8]  
 -152 [6]  
 -38 [1 1/2]

**ISOMETRIC BACK VIEW**  
 -616 [24 1/4]  
 -2743 [108] CEILING HEIGHT A.F.F.

**NOTES:**  
 NOTE: 275 CFM'S PER LINEAR FOOT INCLUDES BOTH SIDES MINIMUM REQD. 1994 CFM'S  
 NOTE: PER NFPA 96, INSTALL HOOD WITH BAFFLE PLATE SUCH THAT FLAMES AND COMBUSTION GASES TRAVEL A MINIMUM OF 18" FROM THE HEAT SOURCE AND NOT LESS THAN 6" FROM THE GREASE REMOVAL DEVICE. COORDINATE WITH G.C. AND HOOD MANUFACTURER'S REPRESENTATIVE TO ENSURE HOOD IS INSTALLED PER THESE REQUIREMENTS.  
 NOTE: OUTER SHELL OF HOOD IS 16 GA. 304 SS MATL. #4 FINISH

**APPROVALS / CERTIFICATIONS**  
 THIS HOOD TYPE 1 HOOD COMPLIES WITH THE FOLLOWING:  
**UL710 / ULC-5646**  
 STANDARD FOR EXHAUST HOOD AND RELATED CONTROLS FOR COMMERCIAL AND INSTITUTIONAL COOKING EQUIPMENT  
**NFPA96**  
 NATIONAL FIRE PROTECTION ASSOCIATION - STD 96  
**NSF2**  
 NATIONAL SANITATION FOUNDATION NO. 2 "FOOD SERVICE EQUIPMENT"  
**NOTE:** THE EXHAUST AIR FLOW RATES WERE ESTABLISHED UNDER CONTROLLED LABORATORY CONDITIONS. GREATER EXHAUST RATES MAY BE REQUIRED FOR COMPLETE VAPOR AND SMOKE REMOVAL IN SPECIFIC INSTALLATIONS.  
**FILTERS/GREASE REMOVAL**  
 THIS HOOD UTILIZES A COMBINATION OF FLAMEGUARD SS TYPE-S 12X16 AND/OR 12X20 ARE KASON TRAPPER S/S FILTERS 7001 SERIES 12X16 812020 MUST BE UL LISTED STAINLESS STEEL GREASE FILTERS  
 THEY MUST BE INSTALLED AT ALL TIMES DURING VENTILATION HOOD OPERATION  
 THIS UNIT REQUIRES: FILTERS (8)  
 FLAMEGUARD FILTER, S/S BAFFLE TYPE VI (8) 12X20  
 (NOTE) HOOD INCLUDES TEMPERATURE INTERLOCK SYSTEM

**REVISION HISTORY**

REV	CHANGE DESC	REV DATE	ENG
-	First Check In		

**BILL OF MATERIALS**

ITEM NO.	QTY REQD.	PART NUMBER	REV	DESCRIPTION	MATERIAL
1	1	WTB1603.5100	-	LIQUID LINE ASSEMBLY	
2	1	WTB1603.5200	-	DETECTION LINE ASSEMBLY	

**DATE:** 8/11/2022 **MATERIAL:** N/A **REV:** B **REVISION:** 20230019 FR **DATE:** 1/10/2023 **CUSTOMER:**  
**DRAWN:** G.Oviedo **WIDTH:** N/A  
**WEIGHT:** N/A **GRAIN LENGTH:** N/A **TOLERANCES:** UNLESS OTHERWISE SPECIFIED: X.XX.XXX" ±1.00 mm ±0.039" X.XX.XXX" ±0.75 mm ±0.029" **UNITS:** mm [in]  
**COMMENTS:** THESE DRAWINGS AND SPECIFICATION ARE THE PROPERTY OF H&K AND SHALL NOT BE REPRODUCED OR COPIED OR TRANSMITTED TO A THIRD PARTY WITHOUT THE WRITTEN PERMISSION OF H&K. **SIZE:** A3 **SHEET:** 2 OF 3 **TITLE:** 87" DOUBLE SIDED CLAM SHELL GRILL HOOD **ITEM NO.:** WTB1603

**metric** ALL DOCUMENTATION RELATED TO THIS UNIT IS RELEASED ON METRIC SYSTEMA (TODA LA DOCUMENTACION RELACIONADA CON ESTA UNIDAD ESTA LIBERADA EN SISTEMA METRICO)

**DOUBLE SIDE GRILL HOOD SUPPLIED WITH (1) 3.0 GAL TANK**  
**DOUBLE SIDE GRILL HOOD INCLUIDO CON (1) TANQUE DE 3.0 GAL**

**ISOMETRIC VIEW**

Labels: 1W NOZZLE DUCT, DETECTION LINE LINEA DE DETECCION, LIQUID LINE LINEA DE LIQUIDO, #2120 NOZZLE & #418569 SWIVEL ADAPTOR, #1N NOZZLE PLENUM, #1N NOZZLE ADAPTOR, #2120 NOZZLE & #418569 SWIVEL ADAPTOR

**REVISION HISTORY**

REV	CHANGE DESC	REV DATE	ENG
-	First Check In		

**BILL OF MATERIALS**

ITEM NO.	QTY REQD.	PART NUMBER	REV	DESCRIPTION	MATERIAL
1	1	WTB1603.5100	-	LIQUID LINE ASSEMBLY	
2	1	WTB1603.5200	-	DETECTION LINE ASSEMBLY	

**DATE:** 8/9/2022 **MATERIAL:** N/A **REV:** - **REVISION:** - **DATE:** 1/10/2023 **CUSTOMER:**  
**DRAWN:** G.Oviedo **WIDTH:** N/A  
**WEIGHT:** 5,25 kg **GRAIN LENGTH:** N/A **TOLERANCES:** UNLESS OTHERWISE SPECIFIED: X.XX.XXX" ±1.00 mm ±0.039" X.XX.XXX" ±0.75 mm ±0.029" **UNITS:** mm [in]  
**COMMENTS:** THESE DRAWINGS AND SPECIFICATION ARE THE PROPERTY OF H&K AND SHALL NOT BE REPRODUCED OR COPIED OR TRANSMITTED TO A THIRD PARTY WITHOUT THE WRITTEN PERMISSION OF H&K. **SIZE:** A3 **SHEET:** 1 OF 1 **TITLE:** ANSUL ASSY **ITEM NO.:** WTB1603.5000

**ANSUL BOX FRONT**

**REVISION HISTORY**

REV	CHANGE DESC	REV DATE	ENG
-	First Check In		

**BILL OF MATERIALS**

ITEM NO.	QTY REQD.	PART NUMBER	REV	DESCRIPTION	MATERIAL
1	1	A-12-013	-	3 GAL TANKSHELL W/ADAPTER #429862	Generic
2	6	A-12-022	-	FUSIBLE LINK, 165F DEG, #415739	Generic
3	2	A-12-045	-	PULLY ELBOW #423251	Generic
4	1	A-12-429853	-	R102 MECH. RELEASE ASSY #429853	Generic
5	2	E-8-64	-	CONNECTOR, 1/2 STR. R/T #TC601	Generic
6	1	A-12-006L	-	SWITCH, DUAL SNAP ACTION #423879 WITH LEADS	Generic
7	1	A-12-080	-	WIRE ROPE (50' STAINLESS STEEL)	Generic

**DATE:** 6/3/2013 **MATERIAL:** N/A **SYN:** - **REVISION:** - **DATE:** - **CUSTOMER:**  
**DRAWN:** D.Boote **WIDTH:** N/A  
**SCALE:** N/A **GRAIN LENGTH:** N/A **TOLERANCES:** UNLESS OTHERWISE SPECIFIED: X.XX.XXX" ±1.00 mm ±0.039" X.XX.XXX" ±0.75 mm ±0.029" **UNITS:** mm [in]  
**COMMENTS:** THESE DRAWINGS AND SPECIFICATION ARE THE PROPERTY OF H&K AND SHALL NOT BE REPRODUCED OR COPIED OR TRANSMITTED TO A THIRD PARTY WITHOUT THE WRITTEN PERMISSION OF H&K. **SIZE:** B **SHEET:** 1 OF 1 **TITLE:** REMOTE ANSUL SYSTEM **ITEM NO.:** A-WTB1263

**FOR REFERENCE ONLY**  
 THE HVAC CONTRACTOR SHALL FURNISH AND INSTALL A COMPLETE AUTOMATIC FIRE PROTECTION SYSTEM FOR THE RANGE HOODS APPROVED EQUAL TO ANSUL SYSTEM. COMPLETE HOOD AND ANSUL SYSTEM INFORMATION TO BE SUBMITTED BY OTHERS IN FUTURE SUBMISSION.

PREPARED FOR:



3420 Torrington Way, Ste 210  
 Charlotte, NC 28227  
 (704) 565-7070  
 (203) 630-2815 Fax

© 2024 BL COMPANIES, INC. THESE DRAWINGS SHALL NOT BE UTILIZED BY ANY PERSON, FIRM OR CORPORATION WITHOUT THE SPECIFIC WRITTEN PERMISSION OF BL COMPANIES.

Date	Description
10/18/2024	PROTOTYPE UPDATE



Seal / Signature

**Project Name**  
 WHATABURGER DAPHNE, AL

**Date:** 10.16.2024

**Project Number**  
 2201817

**Description**  
 HOOD DRAWINGS

**Scale**  
 NOT TO SCALE

**M8.2**