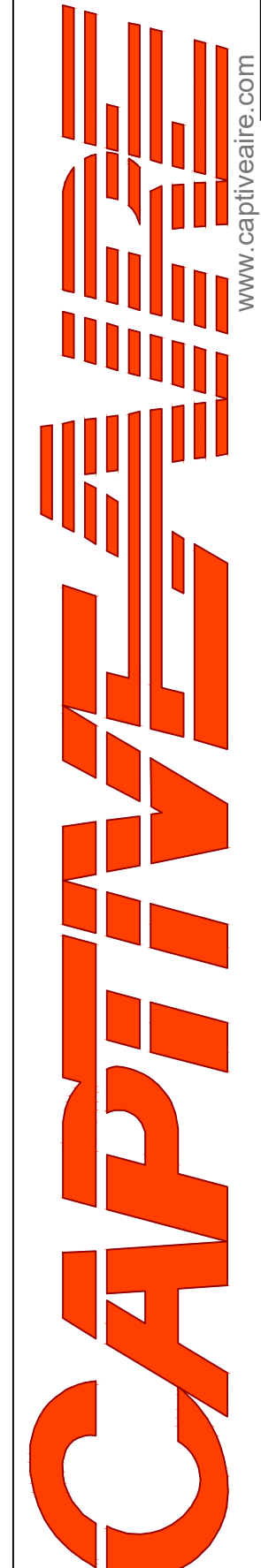

DUCTWORK #1 PARTS - JOB#5304523 DUCT RUN

REVISIONS	
DESCRIPTION	DATE

  
 Air Solutions
   
 1320 East Kemper Rd., Ste. 4210, Cincinnati, OH, 45246 PHONE: (513) 860-5555 EMAIL: reg120@captiveair.com

Chimak LLC (Riverside Chicken) REVISION

405 Scott Blvd,  
Covington, KY, 41011

DATE: 2/15/2022

DWG.#:  
5304523

DRAWN BY:

SCALE:  
Not To Scale

MASTER DRAWING

SHEET NO.  
1

TAG	PART #	CFM	GPM	ZONE	COVEREDBY	SP	WEIGHT	VELOCITY	QTY	DESCRIPTION
P1 ASSEMBLED W/P2	DW14TEASY	2266		1		-0.2258	15.95	2119.71	1	SINGLE WALL DUCT TEE, 14" DUCT, ASSEMBLY.
P2 ASSEMBLED W/P1 Q=S	DW1415ADKIT						3.72		1	DUCT ACCESS DOOR WITH HANDLE & GREASE DAM, FOR 14" DUCT USE 15" DOOR. STAINLESS STEEL.
P3	DW1430ASY	2266				-0.1563	6.28	2119.71	1	SINGLE WALL DUCT 30 DEGREE ELBOW, 14" DUCT, ASSEMBLY.
P4	DW1417LT	2266				-0.0111	8.22	2119.71	1	SINGLE WALL DUCT 14" DIAMETER, 17" LONG, FLANGE AT BOTH ENDS. STAINLESS STEEL.
P5 ASSEMBLED W/P6	DW1424AJDKIT	2266				-0.0079	14.56	2119.71	1	SINGLE WALL DUCT ADJUSTABLE, 14" DIAMETER, 23.5" LONG, FLANGE AT ONE END WITH A 14" ADJUSTABLE COLLAR - STAINLESS STEEL.
P6 ASSEMBLED W/P5	DW23514TPDBEX	2266					8.00	2119.71	1	DUCT TO CURB TRANSITION 3/4" DOWN TURN, 23.50" CURB TO 14" DUCT, 16 GA ALUMINIZED. USED ON BDU15 AND DU85. TRANSITION PLATE OD IS 23.5" DESIGNED FOR USE WITH EXHAUST FAN. NON-STANDARD PART.
SYSTEM AT P6						-1.0611	0.00			
P7	DW1417LT						8.22		1	SINGLE WALL DUCT 14" DIAMETER, 17" LONG, FLANGE AT BOTH ENDS. STAINLESS STEEL.
P8	DW1424AJDKIT						14.56		1	SINGLE WALL DUCT ADJUSTABLE, 14" DIAMETER, 23.5" LONG, FLANGE AT ONE END WITH A 14" ADJUSTABLE COLLAR - STAINLESS STEEL.
P9	DW1411LT						5.46		1	SINGLE WALL DUCT 14" DIAMETER, 11" LONG, FLANGE AT BOTH ENDS. STAINLESS STEEL.
P10	DW1418AJDKIT						11.56		1	SINGLE WALL DUCT ADJUSTABLE, 14" DIAMETER, 17.5" LONG, FLANGE AT ONE END WITH A 14" ADJUSTABLE COLLAR - STAINLESS STEEL.
	3M-2000PLUS						0.80		4	DUCT - 3M FIRE BARRIER 2000 PLUS SILICONE - USED AS SEALANT TO SEAL DUCT JOINTS.
	DW14CLASY						1.06		11	DUCT "V" CLAMP WITH NEW DESIGN 14 GA BRACKETS, 14" DUCT, ASSEMBLY.
ADDITIONAL PARTS										
brkt2	DW14SUBRASY						2.96		1	DUCT SUPPORT BRACKET KIT, 14" DUCT, USED FOR HANGING DUCT. 12 GA STEEL, CLEAR ZINC COATING. - 2 RINGS, 4 BRACKETS, & HARDWARE BAG 2.
dw1445	DW1445ASY-V						7.22		1	SINGLE WALL VENT 45 DEGREE ELBOW, 14" VENT, ASSEMBLY. STAINLESS STEEL.
TOTAL WEIGHT							121.57			

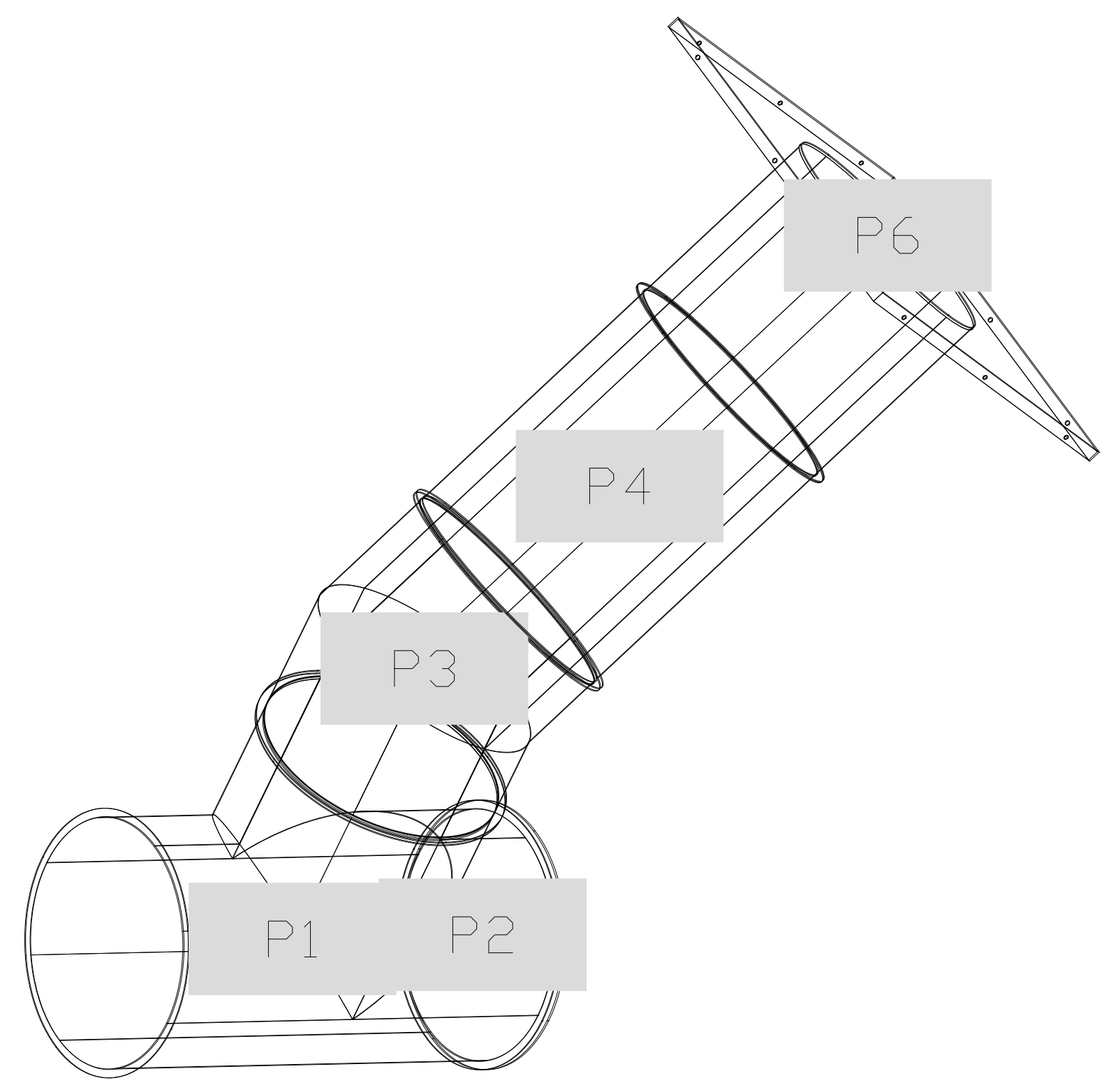
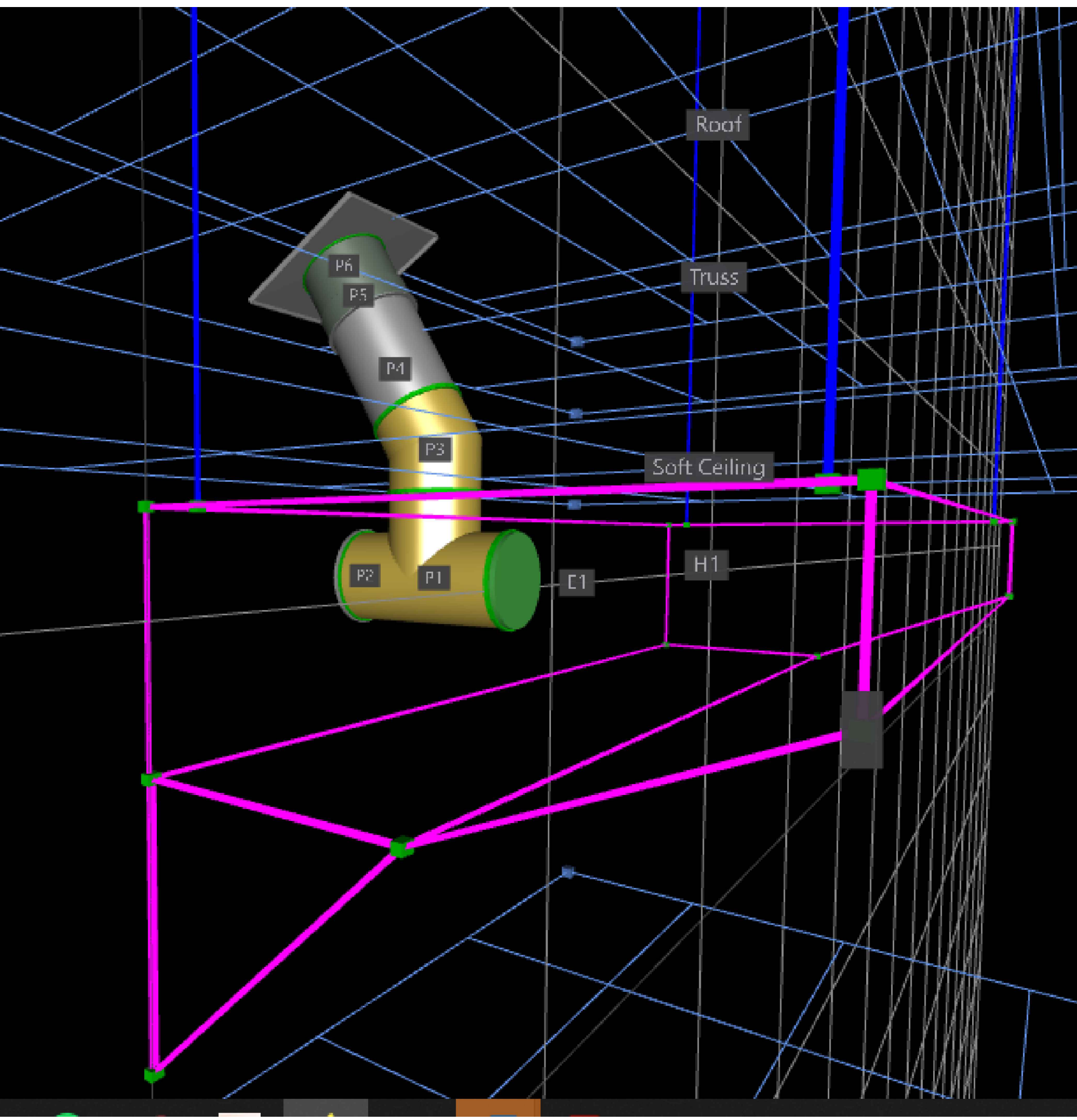

DUCTWORK #1 SIDE VIEW  
DUCT RUN

