

REVISIONS

NO. 1

CAPTIVE AIR®

CHIPPOTLE BOLLINGBROOK
BOLLINGBROOK, IL 60490

DATE: 2/27/2023

BY: [Signature]

SCALE: 1/8" = 1'-0"

DATE: 2/27/2023

BY: [Signature]

SCALE: 1/8" = 1'-0"

SHEET NO. 7

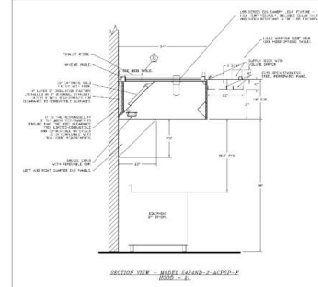

PER SYSTEM INFORMATION - OVERSIGHT

NO.	DATE	BY	CHKD	APP'D	DESCRIPTION
1	2/27/23	[Signature]	[Signature]	[Signature]	ISSUED FOR PERMIT

REVISIONS

NO. 1

CAPTIVE AIR®

CHIPPOTLE BOLLINGBROOK
BOLLINGBROOK, IL 60490

DATE: 2/27/2023

BY: [Signature]

SCALE: 1/8" = 1'-0"

DATE: 2/27/2023

BY: [Signature]

SCALE: 1/8" = 1'-0"

SHEET NO. 7

AYRES

MECHANICAL ELECTRICAL PLUMBING (MEP)

1700 West Highway 30 - Suite 700
Roseville, Minnesota 55113
(651) 638-2606 Fax (651) 638-9618
Project No. 23-0653



CHIPPOTLE BOLLINGBROOK
BOLLINGBROOK, IL 60490



CHIPPOTLE MEXICAN GRILL, INC.
800 FOX 22256
COLUMBUS, OH 43228-2266
800.828.2600
www.chipotle.com

ASBESTOS INFORMATION - OVERSIGHT

NO.	DATE	BY	CHKD	APP'D	DESCRIPTION
1	2/27/23	[Signature]	[Signature]	[Signature]	ISSUED FOR PERMIT

PER SYSTEM INFORMATION - OVERSIGHT

NO.	DATE	BY	CHKD	APP'D	DESCRIPTION
1	2/27/23	[Signature]	[Signature]	[Signature]	ISSUED FOR PERMIT

PER SYSTEM INFORMATION - OVERSIGHT

NO.	DATE	BY	CHKD	APP'D	DESCRIPTION
1	2/27/23	[Signature]	[Signature]	[Signature]	ISSUED FOR PERMIT

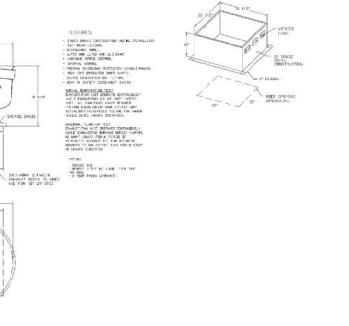

REVISIONS

NO. 1

CAPTIVE AIR®

CHIPPOTLE BOLLINGBROOK
BOLLINGBROOK, IL 60490

DATE: 2/27/2023

BY: [Signature]

SCALE: 1/8" = 1'-0"

DATE: 2/27/2023

BY: [Signature]

SCALE: 1/8" = 1'-0"

SHEET NO. 7

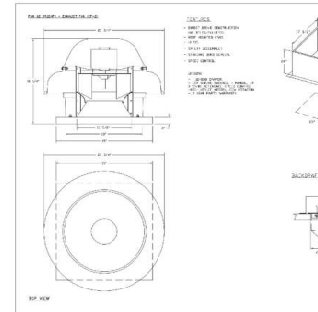

REVISIONS

NO. 1

CAPTIVE AIR®

CHIPPOTLE BOLLINGBROOK
BOLLINGBROOK, IL 60490

DATE: 2/27/2023

BY: [Signature]

SCALE: 1/8" = 1'-0"

DATE: 2/27/2023

BY: [Signature]

SCALE: 1/8" = 1'-0"

SHEET NO. 7

CHIPPOTLE

"BOLLINGBROOK R"

256 S WEBER STREET
BOLLINGBROOK, IL 60490

Issue Record:

NO.	DATE	BY	CHKD	APP'D	DESCRIPTION
1	2/27/23	[Signature]	[Signature]	[Signature]	ISSUED FOR PERMIT

Permit Set:

NO.	DATE	BY	CHKD	APP'D	DESCRIPTION
1	2/27/23	[Signature]	[Signature]	[Signature]	ISSUED FOR PERMIT

Drawn: [Signature]

Checked: [Signature]

RD: [Signature]

Project No: [Signature]

2022-2023

Comments:

HOOD DRAWINGS

M701

