



Lennox National Accounts Project Submittal

Project Name: Barnes & Noble #2934 - Fayetteville, NC
Project Number: 866673
Project Altitude: 263
Project Location:
121 GLENSFORD DR
FAYETTEVILLE, North Carolina US

Date: 4/27/2025
Quote: 582978
Roof Top Units: 5
Split Systems: 0

Customer: Barnes & Noble Inc
Engineer: Pending Engineer
National Account: Barnes & Noble Inc

Table of Contents

Tag	Qty	Model	Description
<u>RTU 2,5</u>	2	LGT150H5E	LGT150H5E-G 12.5T
<u>RTU 4</u>	1	LGT060H5E	LGT060H5E-G 5T
<u>RTU 7</u>	1	LGT036H5E	LGT036H5E-G 3T
<u>RTU 8</u>	1	LGT102H5E	LGT102H5E-G 8.5T
<u>Miscellaneous Items</u>			

Revit® Building Information Modeling (BIM) - [Click here](#)

AutoCAD® Templates - [Click here](#)



Lennox National Accounts Project Submittal

Tag: RTU 2,5
 Model: LGT150H5E - LGT150H5E-G 12.5T

UNIT OVERVIEW

Voltage	IEER EER	MCA/MOCP (amp)	Gross Cooling Ttl/Sens (MBH)	Net Cooling Ttl/Sens (MBH)	Supply Air Flow (cfm)	ESP/TSP (in.WC)	EAT DB/WB (°F)	LAT DB/WB (°F)
460V 3Ph 60Hz	15.4 10.8	29 / 35	149.6 / 110.7	138.2 / 99.3	5,000	0.50 / 1.56	80.0 / 67.0	58.8 / 57.2

COOLING

Cooling Performance		Temperatures (DB/WB °F)	
Gross Cooling (Ttl/Sens)	149.6 / 110.7 MBH	Ambient	95.0
Net Cooling (Ttl/Sens)	138.2 / 99.3 MBH	Entering	80.0 67.0
Coil Moisture Removal	36.66 lb/hr	Total Leaving – (Coil)	58.8 57.2
System Moisture Removal	36.66 lb/hr	Total Leaving – (Unit)	60.6 57.8

ARI Performance		Compressors		Refrigerant		Condensate Drain	
ARI Cooling	142.0 / 138.0 MBH	Cooling Stages	3.0	Type	R-454B	Qty	1
ARI Power	12,800 W	Compressor Qty	2	Charge	12 LBS. 6 OZ.	Size	1 in.
		Compressor RLA	18.2 amp			Pipe Thread	npt

HUMIDITROL - HOT GAS REHEAT

Humiditrol Dehumidification Performance		Temperatures (DB/WB °F)	
Gross Cooling - Stage 1(Ttl/Sens)	23.7 / 11.4 MBH	Ambient	95.0
Gross Cooling - Stage 2 (Ttl/Sens)	90.4 / 57.9 MBH	Entering	80.0 67.0
Moisture Removal - Stage 1	11.6 lb/hr	Total Leaving – (Stage 1)	77.8 65.6
Moisture Removal - Stage 2	30.7 lb/hr	Total Leaving – (Stage 2)	69.0 61.3

HEATING

Heating Performance		Temperatures (DB/WB °F)		Specifications	
Output (High/Low)	194.0 / 126.4 MBH	Total Leaving	35.9	Heat Stages	2
Input (High/Low)	240.0 / 156.0 MBH			Thermal Efficiency	81.0%
Gas Heat Rise	35.9 °F			Gas Line Size	0.75 in.
				Gas Pressure	7 in.WC

VENTILATION

Air Flow (cfm)		Supply Fan		Air Resistance (in.WC)	
Supply	5,000	Nominal Power	3.75 hp	Total	1.56
		Required Power	3.60 hp	Ext Supply	0.50
		Drive Type	ECM Direct Drive		
		Required Watts	2,681 W		
		Exh Fan Nom HP	0.33 hp		

AIR RESISTANCE - OPTIONS/ACCESSORIES (in.WC)

Wet Coil	Humiditrol	Heat	Economizer	Filters	Diffuser	Exhaust	ERW
0.20	0.08	0.43	0.29	0.06			

ELECTRICAL

Voltage	460V 3Ph / 60Hz	Compressor RLA	18.2 amp
MCA	29 amp	Condenser FLA	3.0 amp
MOCP	35 amp	Supply Fan FLA	4.3 amp
Oper Range-Nom Volt	+/- 10%	Exh Fan Mtr FLACooling FLA	1.3 amp26.8 amp
		Total	

ADDITIONAL DATA

Cabinet	101.25 in. x 60.12 in. x 46.88 in.	Total Weight	1,289 lb
Downflow Supply	20.0 in. x 28.0 in.	Base Unit Net Weight	1,120 lb
Downflow Return	24.0 in. x 27.0 in.	OAS/Econ Weight	86 lb
Filters	(4) 20.0 in. x 25.0 in. x 2.0 in.	Exhaust Weight	31 lb
Sound Rating	89 dBA	Humiditrol Weight	20 lb
		Gas Heat Weight	32 lb





Lennox National Accounts Project Submittal

Tag: RTU 2,5

Factory Installed Options

- High Performance Economizer Factory Installed
- Single Enthalpy High Performance Economizer Direct Drive
- Unit Orientation Downflow
- Supply Fan: Multi-Speed ECM Direct Drive 440V/460V/480V 3Phase
- 80Amp Non-Fused Disconnect Factory Installed
- Built-in BACnet IP and MS/TP (standard)
- Refrigerant R-454B
- Supply Motor - 3.75 Hp - DirectPlus w/MSAV
- Std Static Power Exhaust Fan Factory Installed 240K A.S. (Dual Stage)
- Hinged Access Doors Factory Installed
- 15A GFCI Factory Installed/Field Wired
- Environ Condenser Coil System Factory Installed
- Humiditrol Factory Installed
- 2" MERV8 - Filter Factory installed

Field Installed Accessories

Catalog Number	Qty	Description
17M50	2	Humidity Sensor Kit Field Installed
23V86	2	CO2 Sensors - Wall-mount, white plastic cover, no display Field Installed
Y3027	2	BE RTS2-AOS Multi Signal Accessory

Product Features

Cabinet

- Hinged Access Panels
- Durable Outdoor Enamel Paint Finish
- Totally Enclosed Outdoor Fan Motor
- PVC Coated Fan Guard
- Corrosion-Resistant Removable, Reversible Drain Pan
- Isolated Compressor Compartment

Cooling System

- Scroll Compressor
- Expansion Valves
- High Capacity Driers
- Crankcase Heater
- System can operate from 0°F to 125°F without any additional controls
- Pre-charged Refrigeration System
- Timed Off Control
- Internal Pressure Relief Valve
- Humiditrol - Hot Gas Reheat Dehumidification System

Heating System

- Redundant Automatic Gas Valve with Manual Shut-off
- Electronic Flame Sensor
- Direct Spark Ignition
- Inshot Burners
- AGA-CGA Certified
- If configured for room sensor control, additional staging may be possible. Refer to performance tables within the EHB

Control System

- Fan and Limit Controls
- Overload Protection
- Microprocessor Controls – Lennox® CORE Control System
- Auto reset high & low pressure switch with strike 3 lockout feature in Lennox® CORE Control System
- Built-in BACnet IP & MS/TP
- Phase/Voltage Detection
- Return Air Sensor Factory Installed
- Outdoor Air Sensor Factory Installed
- Factory Installed Discharge Air Sensor



Lennox National Accounts Project Submittal

Refrigerant Detection System (RDS) and mitigation response, per UL safety standard 60335-2-40

Compliance

Components are Bonded for Grounding

Factory Test Operated

All models are ASHRAE 90.1 energy efficiency compliant and meet or exceed requirements of Section 6.8

All models meet DOE 2023 energy efficiency standards

All models are compliant with and listed to UL standard 60335-2-40

Model meets California Code of Regulations, Title 24 and ASHRAE 90.1-2016 Section 6.4.3.10 requirements for staged airflow

Model meets HCAI (formerly OSHPD) OSP and Special Seismic Certification (Number: OSP-0596) and meet 2018 International Building Code (IBC), 2019

California Building Code (CBC) ASCE 7, and ICC-ES AC156

ISO 9001 Registered Manufacturing Quality System

Only refrigerants in compliance with New York State regulations can be used in the state of New York

Warranty

Limited warranty on aluminized heat exchanger of 10 years

Limited warranty on compressor of 5 years

Limited warranty on Environ Coil System of 3 years

Limited warranty on High Performance Economizer of 5 years

Limited warranty on all other components of 1 year

Limited warranty on Lennox® CORE Control System of 3 years

See Limited Warranty Certificate included with unit for details



Lennox National Accounts Project Submittal

Corner Weights (lb)						Center of Gravity (in.)					
AA		BB		CC		DD		EE		FF	
Base	Max	Base	Max	Base	Max	Base	Max	Base	Max	Base	Max
316	359	284	314	304	393	345	393	46.50	45.50	24.50	25.50

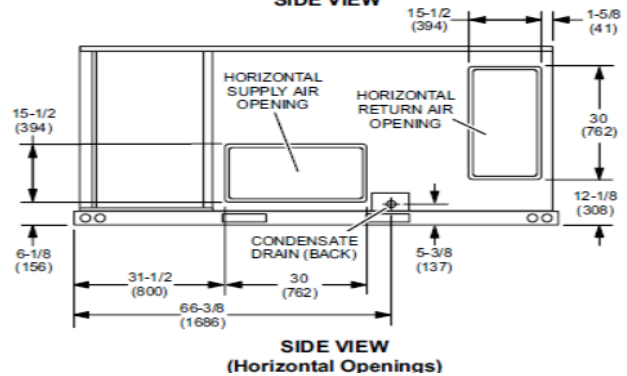
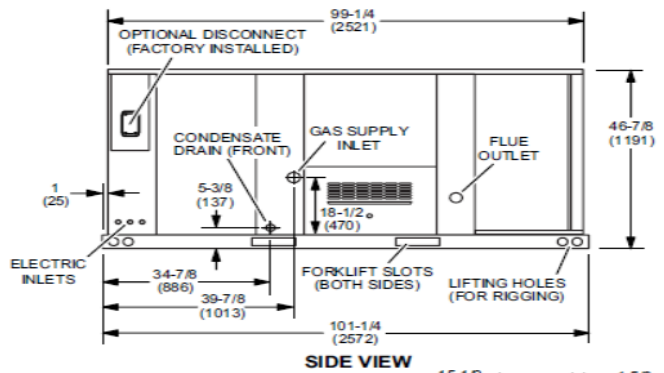
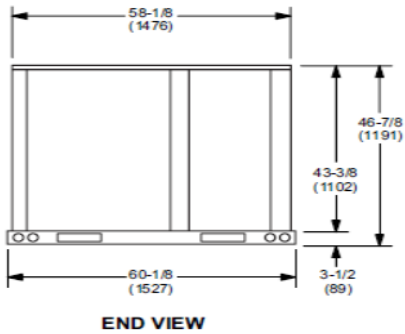
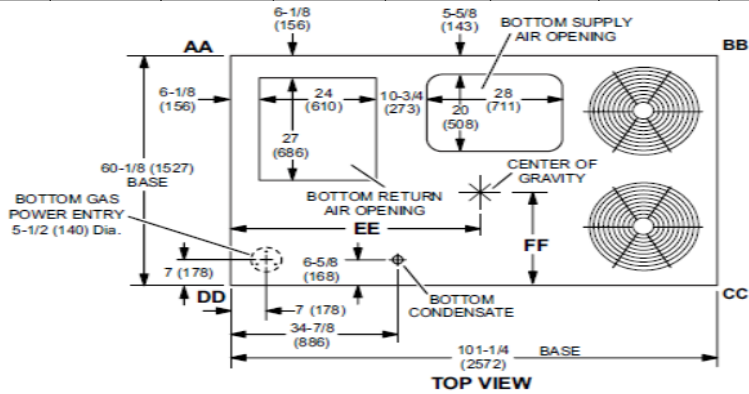

OUTDOOR AIR HOOD DETAIL

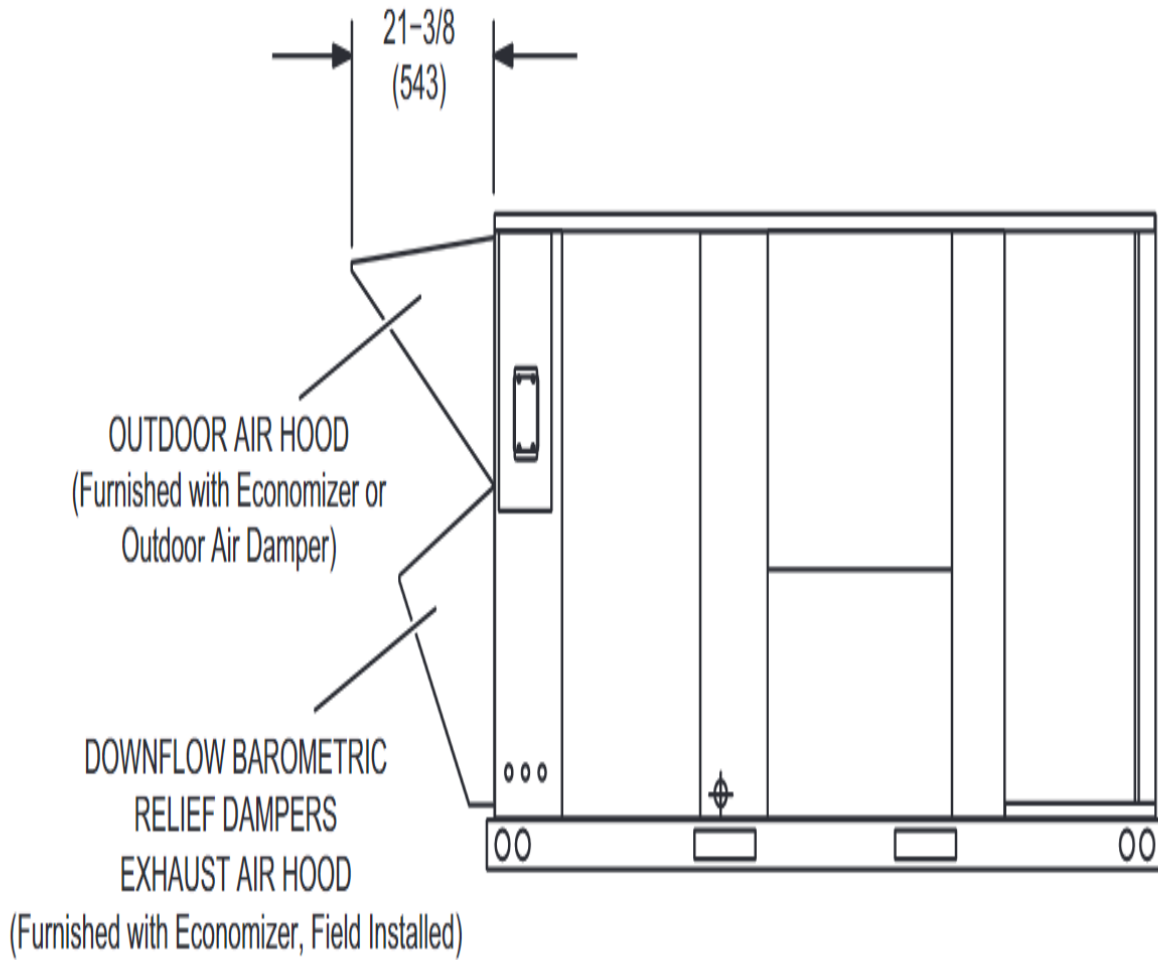



Lennox National Accounts Project Submittal

UNIT CLEARANCES

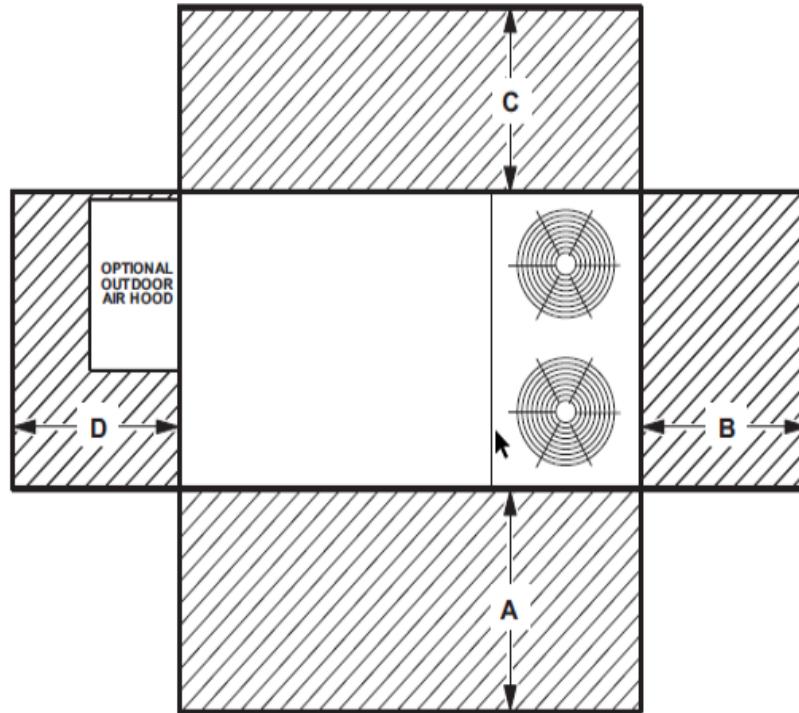

¹ Unit Clearance	A		B		C		D		Top Clearance
	in.	mm	in.	mm	in.	mm	in.	mm	
Service Clearance	60	1524	36	914	36	934	60	1524	Unobstructed
Clearance to Combustibles	36	914	1	25	1	25	1	25	
Minimum Operation Clearance	36	914	36	914	36	914	36	914	

NOTE - Entire perimeter of unit base requires support when elevated above the mounting surface.

¹ Service Clearance - Required for removal of serviceable parts.

Clearance to Combustibles - Required clearance to combustible material.

Minimum Operation Clearance - Required clearance for proper unit operation.



Lennox National Accounts Project Submittal

Tag: RTU 4
 Model: LGT060H5E - LGT060H5E-G 5T

UNIT OVERVIEW

Voltage	SEER2 EER2	MCA/MOCP (amp)	Gross Cooling Ttl/Sens (MBH)	Net Cooling Ttl/Sens (MBH)	Supply Air Flow (cfm)	ESP/TSP (in.WC)	EAT DB/WB (°F)	LAT DB/WB (°F)
460V 3Ph 60Hz	16.4 12.5	14 / 15	65.6 / 49.2	62.0 / 45.6	2,000	0.50 / 0.76	80.0 / 67.0	56.4 / 56.1

COOLING

Cooling Performance		Temperatures (DB/WB °F)	
Gross Cooling (Ttl/Sens)	65.6 / 49.2 MBH	Ambient	95.0
Net Cooling (Ttl/Sens)	62.0 / 45.6 MBH	Entering	80.0
Coil Moisture Removal	15.46 lb/hr	Total Leaving – (Coil)	56.4
System Moisture Removal	15.46 lb/hr	Total Leaving – (Unit)	58.2
			56.7

ARI Performance		Compressors		Refrigerant		Condensate Drain	
ARI Cooling	61.6 / 60.0 MBH	Cooling Stages	2.0	Type	R-454B	Qty	1
ARI Power	4,600 W	Compressor Qty	1	Charge	4 LBS. 14 OZ.	Size	1 in.
		Compressor RLA	6.5 amp			Pipe Thread	npt

HEATING

Heating Performance		Temperatures (DB/WB °F)		Specifications	
Output (High/Low)	121.0 / 92.0 MBH	Total Leaving	55.6	Heat Stages	2
Input (High/Low)	150.0 / 113.0 MBH			Thermal Efficiency NOX	81.0%
Gas Heat Rise	55.6 °F			Gas Line Size	0.5 in.
				Gas Pressure	7 in.WC

VENTILATION

Air Flow (cfm)		Supply Fan		Air Resistance (in.WC)	
Supply	2,000	Nominal Power	1.00 hp	Total	0.76
		Required Power	1.14 hp	Ext Supply	0.50
		Drive Type	ECM Direct Drive		
		Required Watts	849 W		
		Motor Torque	82		
		Exh Fan Nom HP	0.33 hp		

AIR RESISTANCE - OPTIONS/ACCESSORIES (in.WC)

Wet Coil	Humiditrol	Heat	Economizer	Filters	Diffuser	Exhaust	ERW
0.10		0.06	0.05	0.05			

ELECTRICAL

Voltage	460V 3Ph / 60Hz	Compressor RLA	6.5 amp
MCA	14 amp	Condenser FLA	1.4 amp
MOCP	15 amp	Supply Fan FLA	3.7 amp
Oper Range-Nom Volt	+/- 10%	Cooling FLA Total	11.6 amp

ADDITIONAL DATA

Cabinet	85.25 in. x 47.00 in. x 46.88 in.	Total Weight	733 lb
Downflow Supply	20.0 in. x 18.0 in.	Base Unit Net Weight	630 lb
Downflow Return	29.0 in. x 11.0 in.	OAS/Econ Weight	84 lb
Filters	(4) 20.0 in. x 20.0 in. x 2.0 in.	Gas Heat Weight	19 lb
Sound Rating	82 dBA		



Lennox National Accounts Project Submittal

Tag: RTU 4

Factory Installed Options

- High Performance Economizer Factory Installed
- Single Enthalpy High Performance Economizer
- Direct Drive
- Unit Orientation Downflow
- Supply Fan: Multi-Speed ECM Direct Drive
- 440V/460V/480V 3Phase
- 80Amp Non-Fused Disconnect Factory Installed
- Built-in BACnet IP and MS/TP (standard)
- Refrigerant R-454B
- Supply Motor - 1.0 Hp ECM - Multi-Speed Direct Drive
- Barometric Relief Damper Factory Installed
- 150K A.S. (Dual Stage)
- Low Nox Factory Installed
- Hinged Access Doors Factory Installed
- 15A GFCI Factory Installed/Field Wired
- Phase/Voltage Detection Factory Installed
- Environ Evaporator and Condenser Coil System Factory Installed
- 2" MERV8 - Filter Factory installed

Field Installed Accessories

Catalog Number	Qty	Description
Y3027	1	BE RTS2-AOS Multi Signal Accessory

Product Features

Cabinet

- Hinged Access Panels
- Durable Outdoor Enamel Paint Finish
- Totally Enclosed Outdoor Fan Motor
- PVC Coated Fan Guard
- Corrosion-Resistant Removable, Reversible Drain Pan
- Isolated Compressor Compartment

Cooling System

- Scroll Compressor
- Expansion Valves
- High Capacity Driers
- Crankcase Heater
- System can operate from 0°F to 125°F without any additional controls
- Pre-charged Refrigeration System
- Timed Off Control
- Internal Pressure Relief Valve

Heating System

- Redundant Automatic Gas Valve with Manual Shut-off
- Electronic Flame Sensor
- Direct Spark Ignition
- Inshot Burners
- AGA-CGA Certified
- If configured for room sensor control, additional staging may be possible. Refer to performance tables within the EHB

Control System

- Fan and Limit Controls
- Overload Protection
- Microprocessor Controls – Lennox® CORE Control System
- Auto reset high & low pressure switch with strike 3 lockout feature in Lennox® CORE Control System
- Built-in BACnet IP & MS/TP
- Return Air Sensor Factory Installed
- Outdoor Air Sensor Factory Installed
- Factory Installed Discharge Air Sensor
- Refrigerant Detection System (RDS) and mitigation response, per UL safety standard 60335-2-40

Compliance

- Components are Bonded for Grounding



Lennox National Accounts Project Submittal

Factory Test Operated

All models are ASHRAE 90.1 energy efficiency compliant and meet or exceed requirements of Section 6.8

All models meet DOE 2023 energy efficiency standards

All models are compliant with and listed to UL standard 60335-2-40

Model meets California Code of Regulations, Title 24 and ASHRAE 90.1-2016 Section 6.4.3.10 requirements for staged airflow

Model meets HCAI (formerly OSHPD) OSP and Special Seismic Certification (Number: OSP-0596) and meet 2018 International Building Code (IBC), 2019

California Building Code (CBC) ASCE 7, and ICC-ES AC156

ISO 9001 Registered Manufacturing Quality System

Only refrigerants in compliance with New York State regulations can be used in the state of New York

Warranty

Limited warranty on aluminized heat exchanger of 10 years

Limited warranty on compressor of 5 years

Limited warranty on Environ Coil System of 3 years

Limited warranty on High Performance Economizer of 5 years

Limited warranty on all other components of 1 year

Limited warranty on Lennox® CORE Control System of 3 years

See Limited Warranty Certificate included with unit for details



Lennox National Accounts Project Submittal

Corner Weights (lb)						Center of Gravity (in.)					
AA		BB		CC		DD		EE		FF	
Base	Max	Base	Max	Base	Max	Base	Max	Base	Max	Base	Max
131	169	161	208	220	284	179	231	38.25	39.75	19.88	19.88

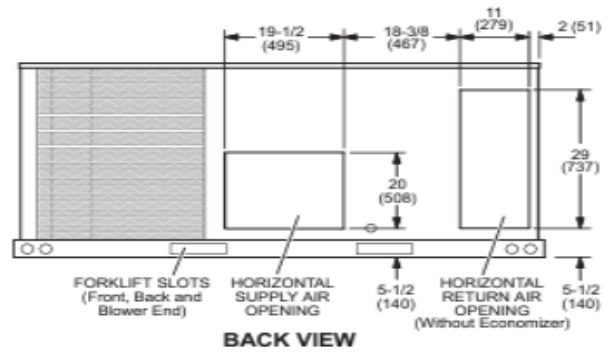
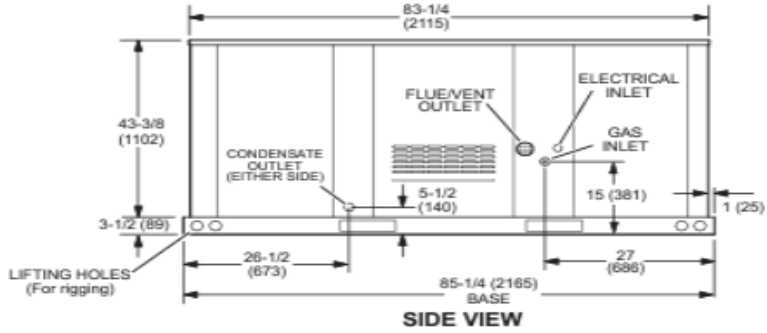
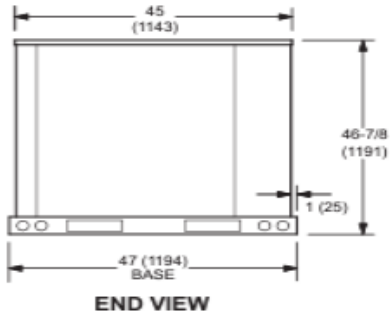
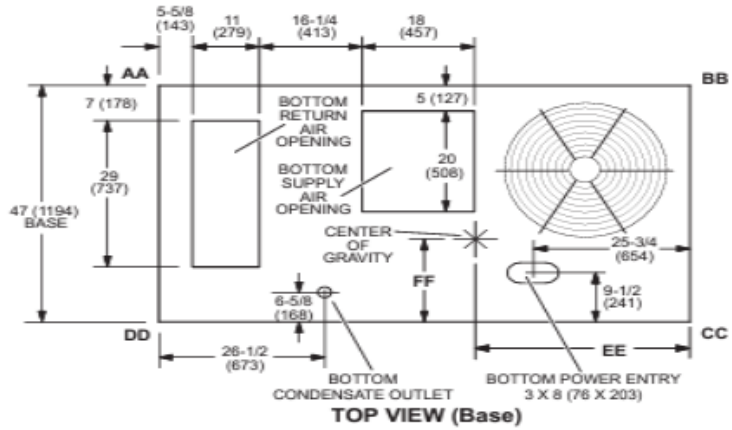



Lennox National Accounts Project Submittal

UNIT CLEARANCES

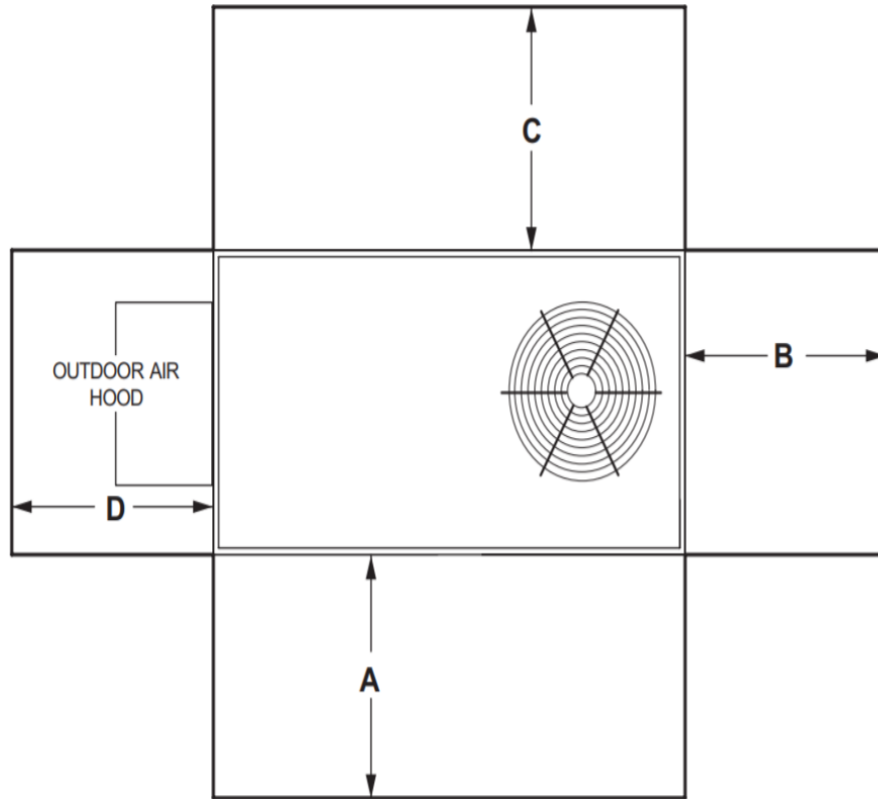

¹ Unit Clearance	A		B		C		D		Top Clearance
	in.	mm	in.	mm	in.	mm	in.	mm	
Service Clearance	48	1219	36	914	36	934	36	914	Unobstructed
Clearance to Combustibles	36	914	1	25	1	25	1	25	
Minimum Operation Clearance	36	914	36	914	36	914	36	914	

NOTE - Entire perimeter of unit base requires support when elevated above the mounting surface.

¹ **Service Clearance** - Required for removal of serviceable parts.

Clearance to Combustibles - Required clearance to combustible material.

Minimum Operation Clearance - Required clearance for proper unit operation.



Lennox National Accounts Project Submittal

Tag: RTU 7
 Model: LGT036H5E - LGT036H5E-G 3T

UNIT OVERVIEW

Voltage	SEER2 EER2	MCA/MOCP (amp)	Gross Cooling Ttl/Sens (MBH)	Net Cooling Ttl/Sens (MBH)	Supply Air Flow (cfm)	ESP/TSP (in.WC)	EAT DB/WB (°F)	LAT DB/WB (°F)
460V 3Ph 60Hz	17.5 13.5	10 / 15	37.8 / 27.6	36.5 / 26.3	1,200	0.50 / 0.62	80.0 / 67.0	58.0 / 56.6

COOLING

Cooling Performance		Temperatures (DB/WB °F)	
Gross Cooling (Ttl/Sens)	37.8 / 27.6 MBH	Ambient	95.0
Net Cooling (Ttl/Sens)	36.5 / 26.3 MBH	Entering	80.0 67.0
Coil Moisture Removal	9.62 lb/hr	Total Leaving – (Coil)	58.0 56.6
System Moisture Removal	9.62 lb/hr	Total Leaving – (Unit)	59.0 57.0

ARI Performance		Compressors		Refrigerant		Condensate Drain	
ARI Cooling	36.6 / 36.0 MBH	Cooling Stages	2.0	Type	R-454B	Qty	1
ARI Power	2,700 W	Compressor Qty	1	Charge	4 LBS. 14 OZ.	Size	1 in.
		Compressor RLA	4.6 amp			Pipe Thread	npt

HEATING

Heating Performance		Temperatures (DB/WB °F)		Specifications	
Output (High/Low)	87.0 / 66.0 MBH	Total Leaving	66.4	Heat Stages	2
Input (High/Low)	108.0 / 81.0 MBH			Thermal Efficiency NOX	81.0%
Gas Heat Rise	66.4 °F			Gas Line Size	0.5 in.
				Gas Pressure	7 in.WC

VENTILATION

Air Flow (cfm)		Supply Fan		Air Resistance (in.WC)	
Supply	1,200	Nominal Power	0.50 hp	Total	0.62
		Required Power	0.41 hp	Ext Supply	0.50
		Drive Type	ECM Direct Drive		
		Required Watts	308 W		
		Motor Torque	66		
		Exh Fan Nom HP	0.33 hp		

AIR RESISTANCE - OPTIONS/ACCESSORIES (in.WC)

Wet Coil	Humiditrol	Heat	Economizer	Filters	Diffuser	Exhaust	ERW
0.03		0.02	0.04	0.03			

ELECTRICAL

Voltage	460V 3Ph / 60Hz	Compressor RLA	4.6 amp
MCA	10 amp	Condenser FLA	1.4 amp
MOCP	15 amp	Supply Fan FLA	2.2 amp
Oper Range-Nom Volt	+/- 10%	Cooling FLA Total	8.2 amp

ADDITIONAL DATA

Cabinet	85.25 in. x 47.00 in. x 46.88 in.	Total Weight	722 lb
Downflow Supply	20.0 in. x 18.0 in.	Base Unit Net Weight	630 lb
Downflow Return	29.0 in. x 11.0 in.	OAS/Econ Weight	84 lb
Filters	(4) 20.0 in. x 20.0 in. x 2.0 in.	Gas Heat Weight	8 lb
Sound Rating	75 dBA		



Lennox National Accounts Project Submittal

Tag: RTU 7

Factory Installed Options

- High Performance Economizer Factory Installed
- Single Enthalpy High Performance Economizer
- Direct Drive
- Unit Orientation Downflow
- Supply Fan: Multi-Speed ECM Direct Drive
- 440V/460V/480V 3Phase
- 80Amp Non-Fused Disconnect Factory Installed
- Built-in BACnet IP and MS/TP (standard)
- Refrigerant R-454B
- Supply Motor - 0.50 Hp ECM - w/ MSAV
- Barometric Relief Damper Factory Installed
- 108K A.S. (Dual Stage)
- Low Nox Factory Installed
- Hinged Access Doors Factory Installed
- 15A GFCI Factory Installed/Field Wired
- Phase/Voltage Detection Factory Installed
- Environ Evaporator and Condenser Coil System Factory Installed
- 2" MERV8 - Filter Factory installed

Field Installed Accessories

Catalog Number	Qty	Description
Y3027	1	BE RTS2-AOS Multi Signal Accessory

Product Features

Cabinet

- Hinged Access Panels
- Durable Outdoor Enamel Paint Finish
- Totally Enclosed Outdoor Fan Motor
- PVC Coated Fan Guard
- Corrosion-Resistant Removable, Reversible Drain Pan
- Isolated Compressor Compartment

Cooling System

- Scroll Compressor
- Expansion Valves
- High Capacity Driers
- Crankcase Heater
- System can operate from 0°F to 125°F without any additional controls
- Pre-charged Refrigeration System
- Timed Off Control
- Internal Pressure Relief Valve

Heating System

- Redundant Automatic Gas Valve with Manual Shut-off
- Electronic Flame Sensor
- Direct Spark Ignition
- Inshot Burners
- AGA-CGA Certified
- If configured for room sensor control, additional staging may be possible. Refer to performance tables within the EHB

Control System

- Fan and Limit Controls
- Overload Protection
- Microprocessor Controls – Lennox® CORE Control System
- Auto reset high & low pressure switch with strike 3 lockout feature in Lennox® CORE Control System
- Built-in BACnet IP & MS/TP
- Return Air Sensor Factory Installed
- Outdoor Air Sensor Factory Installed
- Factory Installed Discharge Air Sensor
- Refrigerant Detection System (RDS) and mitigation response, per UL safety standard 60335-2-40

Compliance

- Components are Bonded for Grounding



Lennox National Accounts Project Submittal

Factory Test Operated

All models are ASHRAE 90.1 energy efficiency compliant and meet or exceed requirements of Section 6.8

All models meet DOE 2023 energy efficiency standards

All models are compliant with and listed to UL standard 60335-2-40

Model meets California Code of Regulations, Title 24 and ASHRAE 90.1-2016 Section 6.4.3.10 requirements for staged airflow

Model meets HCAI (formerly OSHPD) OSP and Special Seismic Certification (Number: OSP-0596) and meet 2018 International Building Code (IBC), 2019

California Building Code (CBC) ASCE 7, and ICC-ES AC156

ISO 9001 Registered Manufacturing Quality System

Only refrigerants in compliance with New York State regulations can be used in the state of New York

Warranty

Limited warranty on aluminized heat exchanger of 10 years

Limited warranty on compressor of 5 years

Limited warranty on Environ Coil System of 3 years

Limited warranty on High Performance Economizer of 5 years

Limited warranty on all other components of 1 year

Limited warranty on Lennox® CORE Control System of 3 years

See Limited Warranty Certificate included with unit for details



Lennox National Accounts Project Submittal

Corner Weights (lb)						Center of Gravity (in.)					
AA		BB		CC		DD		EE		FF	
Base	Max	Base	Max	Base	Max	Base	Max	Base	Max	Base	Max
131	168	161	207	220	283	179	230	38.25	39.75	19.88	19.88

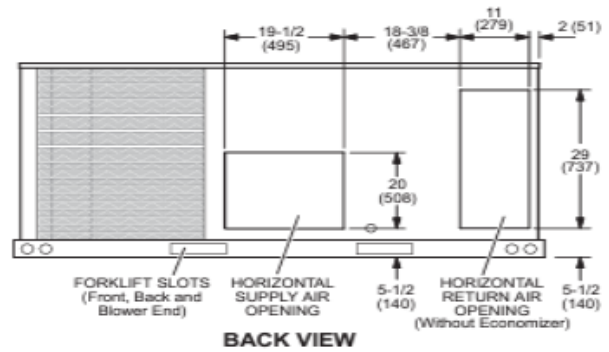
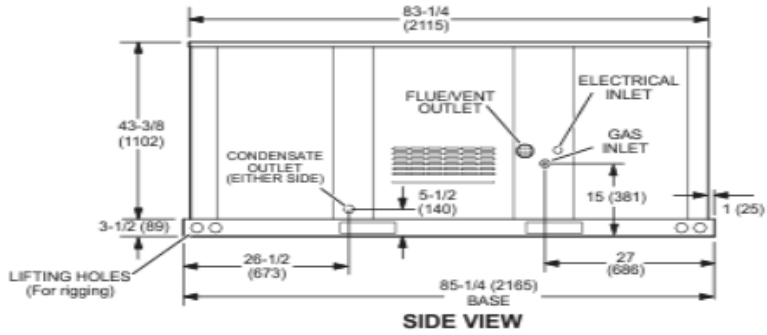
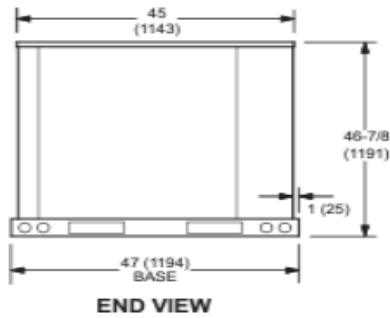
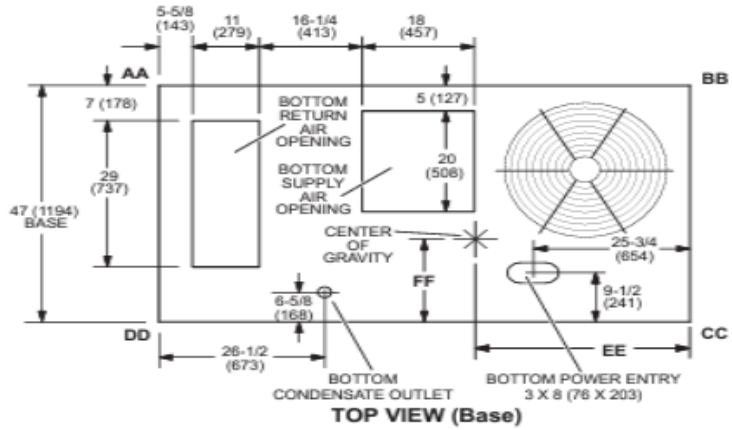



Lennox National Accounts Project Submittal

UNIT CLEARANCES

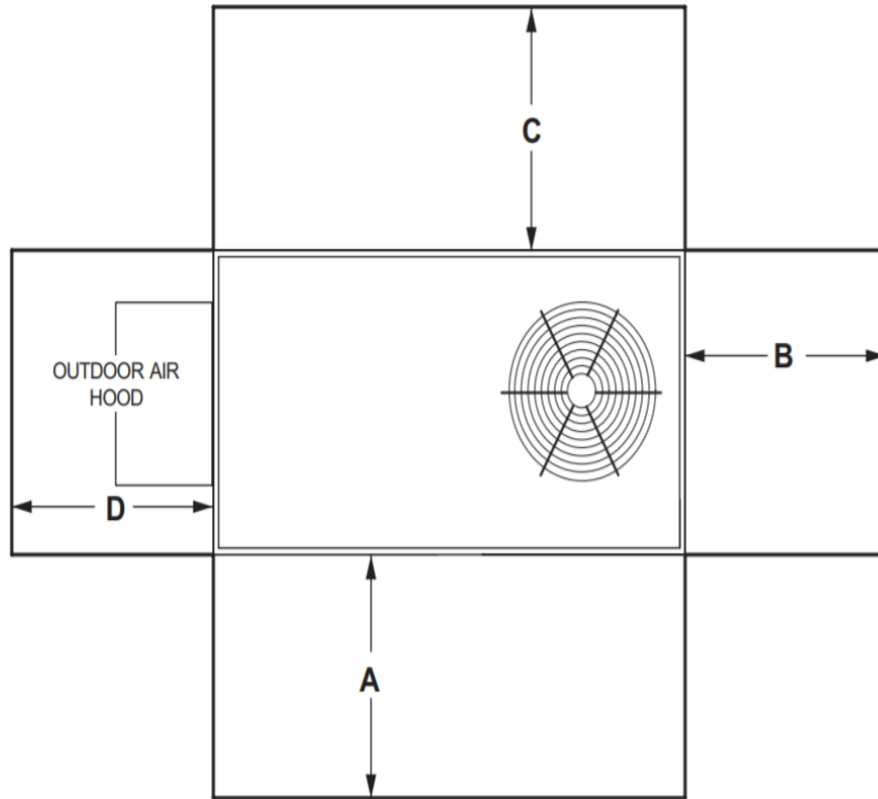

¹ Unit Clearance	A		B		C		D		Top Clearance
	in.	mm	in.	mm	in.	mm	in.	mm	
Service Clearance	48	1219	36	914	36	934	36	914	Unobstructed
Clearance to Combustibles	36	914	1	25	1	25	1	25	
Minimum Operation Clearance	36	914	36	914	36	914	36	914	

NOTE - Entire perimeter of unit base requires support when elevated above the mounting surface.

¹ **Service Clearance** - Required for removal of serviceable parts.

Clearance to Combustibles - Required clearance to combustible material.

Minimum Operation Clearance - Required clearance for proper unit operation.



Lennox National Accounts Project Submittal

Tag: RTU 8
Model: LGT102H5E - LGT102H5E-G 8.5T

UNIT OVERVIEW

Voltage	IEER EER	MCA/MOCP (amp)	Gross Cooling Ttl/Sens (MBH)	Net Cooling Ttl/Sens (MBH)	Supply Air Flow (cfm)	ESP/TSP (in.WC)	EAT DB/WB (°F)	LAT DB/WB (°F)
460V 3Ph 60Hz	16.1 12.1	22 / 25	103.1 / 78.4	98.6 / 73.8	3,400	0.50 / 0.95	80.0 / 67.0	57.9 / 57.0

COOLING

Cooling Performance		Temperatures (DB/WB °F)	
Gross Cooling (Ttl/Sens)	103.1 / 78.4 MBH	Ambient	95.0
Net Cooling (Ttl/Sens)	98.6 / 73.8 MBH	Entering	80.0 67.0
Coil Moisture Removal	23.32 lb/hr	Total Leaving – (Coil)	57.9 57.0
System Moisture Removal	23.32 lb/hr	Total Leaving – (Unit)	59.2 57.5

ARI Performance		Compressors		Refrigerant		Condensate Drain	
ARI Cooling	103.0 / 100.0 MBH	Cooling Stages	3.0	Type	R-454B	Qty	1
ARI Power	8,000 W	Compressor Qty	2	Charge	12 LBS. 2 OZ.	Size	1 in.
		Compressor RLA	12.8 amp			Pipe Thread	npt

HEATING

Heating Performance		Temperatures (DB/WB °F)		Specifications	
Output (High/Low)	194.0 / 126.4 MBH	Total Leaving	52.8	Heat Stages	2
Input (High/Low)	240.0 / 156.0 MBH			Thermal Efficiency	81.0%
Gas Heat Rise	52.8 °F			Gas Line Size	0.75 in.
				Gas Pressure	7 in.WC

VENTILATION

Air Flow (cfm)		Supply Fan		Air Resistance (in.WC)	
Supply	3,400	Nominal Power	3.75 hp	Total	0.95
		Required Power	1.42 hp	Ext Supply	0.50
		Drive Type	ECM Direct Drive		
		Required Watts	1,060 W		
		Exh Fan Nom HP	0.33 hp		

AIR RESISTANCE - OPTIONS/ACCESSORIES (in.WC)

Wet Coil	Humiditrol	Heat	Economizer	Filters	Diffuser	Exhaust	ERW
0.12		0.17	0.15	0.02			

ELECTRICAL

Voltage	460V 3Ph / 60Hz	Compressor RLA	12.8 amp
MCA	22 amp	Condenser FLA	2.6 amp
MOCP	25 amp	Supply Fan FLA	4.3 amp
Oper Range-Nom Volt	+/- 10%	Exh Fan Mtr FLACooling FLA	1.3 amp/21.0 amp
		Total	

ADDITIONAL DATA

Cabinet	101.25 in. x 60.12 in. x 46.88 in.	Total Weight	1,221 lb
Downflow Supply	20.0 in. x 28.0 in.	Base Unit Net Weight	1,095 lb
Downflow Return	24.0 in. x 27.0 in.	OAS/Econ Weight	86 lb
Filters	(4) 20.0 in. x 25.0 in. x 2.0 in.	Exhaust Weight	8 lb
Sound Rating	88 dBA	Gas Heat Weight	32 lb



Lennox National Accounts Project Submittal

Tag: RTU 8

Factory Installed Options

High Performance Economizer Factory Installed
Single Enthalpy High Performance Economizer
Direct Drive
Unit Orientation Downflow
Supply Fan: Multi-Speed ECM Direct Drive
440V/460V/480V 3Phase
80Amp Non-Fused Disconnect Factory Installed
Built-in BACnet IP and MS/TP (standard)
Refrigerant R-454B
Supply Motor - 3.75 Hp - DirectPlus w/MSAV
Barometric Relief Damper Factory Installed
240K A.S. (Dual Stage)
Return Air Adaptor Plate Factory Installed
Hinged Access Doors Factory Installed
15A GFCI Factory Installed/Field Wired
Environ Condenser Coil System Factory Installed
2" MERV8 - Filter Factory installed

Field Installed Accessories

Catalog Number	Qty	Description
23V86	1	CO2 Sensors - Wall-mount, white plastic cover, no display Field Installed
Y3027	1	BE RTS2-AOS Multi Signal Accessory

Product Features

Cabinet

Hinged Access Panels
Durable Outdoor Enamel Paint Finish
Totally Enclosed Outdoor Fan Motor
PVC Coated Fan Guard
Corrosion-Resistant Removable, Reversible Drain Pan
Isolated Compressor Compartment

Cooling System

Scroll Compressor
Expansion Valves
High Capacity Driers
Crankcase Heater
System can operate from 0°F to 125°F without any additional controls
Pre-charged Refrigeration System
Timed Off Control
Internal Pressure Relief Valve

Heating System

Redundant Automatic Gas Valve with Manual Shut-off
Electronic Flame Sensor
Direct Spark Ignition
Inshot Burners
AGA-CGA Certified
If configured for room sensor control, additional staging may be possible. Refer to performance tables within the EHB

Control System

Fan and Limit Controls
Overload Protection
Microprocessor Controls – Lennox® CORE Control System
Auto reset high & low pressure switch with strike 3 lockout feature in Lennox® CORE Control System
Built-in BACnet IP & MS/TP
Phase/Voltage Detection
Return Air Sensor Factory Installed
Outdoor Air Sensor Factory Installed
Factory Installed Discharge Air Sensor
Refrigerant Detection System (RDS) and mitigation response, per UL safety standard 60335-2-40

Compliance



Lennox National Accounts Project Submittal

Components are Bonded for Grounding
Factory Test Operated
All models are ASHRAE 90.1 energy efficiency compliant and meet or exceed requirements of Section 6.8
All models meet DOE 2023 energy efficiency standards
All models are compliant with and listed to UL standard 60335-2-40

Model meets California Code of Regulations, Title 24 and ASHRAE 90.1-2016 Section 6.4.3.10 requirements for staged airflow
Model meets HCAI (formerly OSHPD) OSP and Special Seismic Certification (Number: OSP-0596) and meet 2018 International Building Code (IBC), 2019 California Building Code (CBC) ASCE 7, and ICC-ES AC156
ISO 9001 Registered Manufacturing Quality System
Only refrigerants in compliance with New York State regulations can be used in the state of New York

Warranty

Limited warranty on aluminized heat exchanger of 10 years
Limited warranty on compressor of 5 years
Limited warranty on Environ Coil System of 3 years
Limited warranty on High Performance Economizer of 5 years
Limited warranty on all other components of 1 year
Limited warranty on Lennox® CORE Control System of 3 years
See Limited Warranty Certificate included with unit for details



Lennox National Accounts Project Submittal

Corner Weights (lb)						Center of Gravity (in.)					
AA		BB		CC		DD		EE		FF	
Base	Max	Base	Max	Base	Max	Base	Max	Base	Max	Base	Max
294	340	265	297	288	318	328	372	46.50	45.50	24.50	25.50

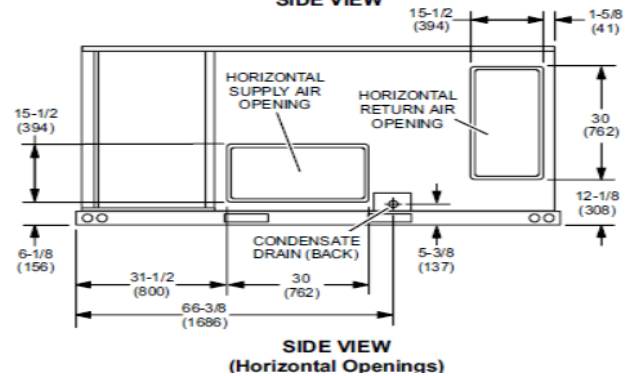
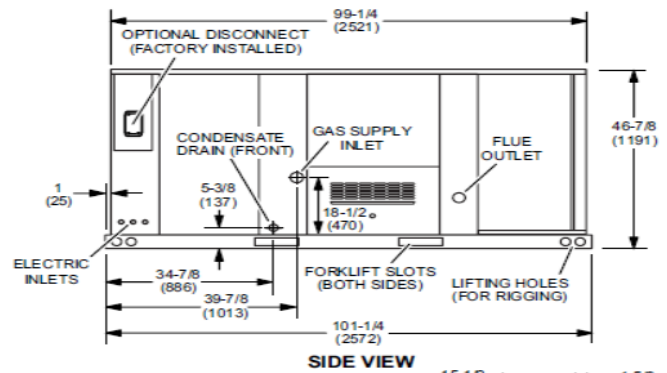
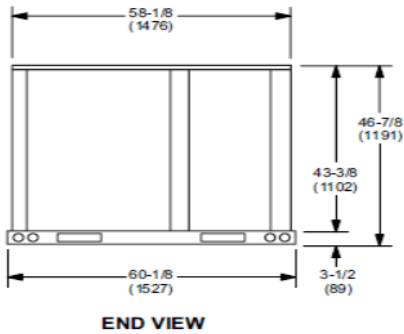
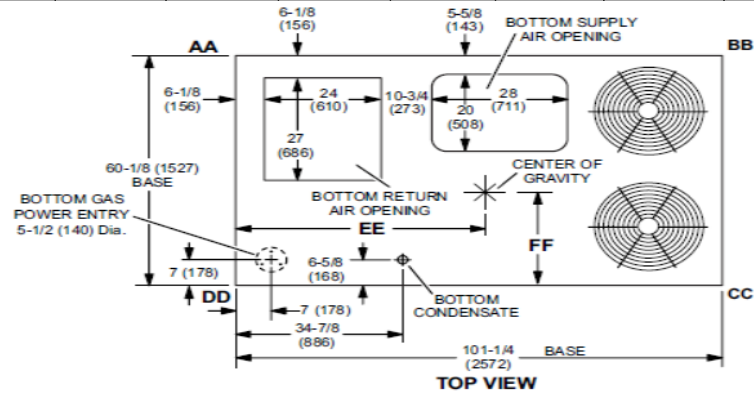

OUTDOOR AIR HOOD DETAIL

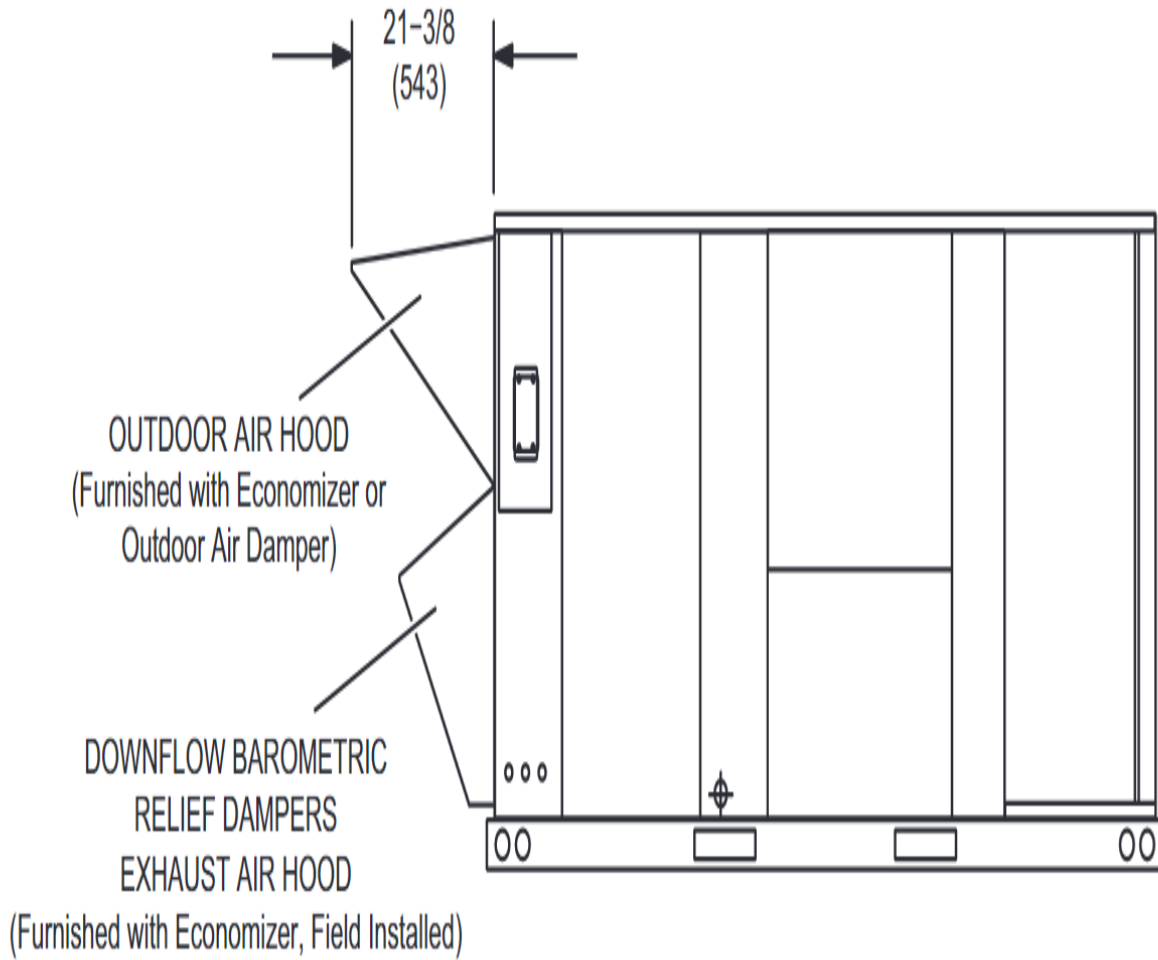



Lennox National Accounts Project Submittal

UNIT CLEARANCES

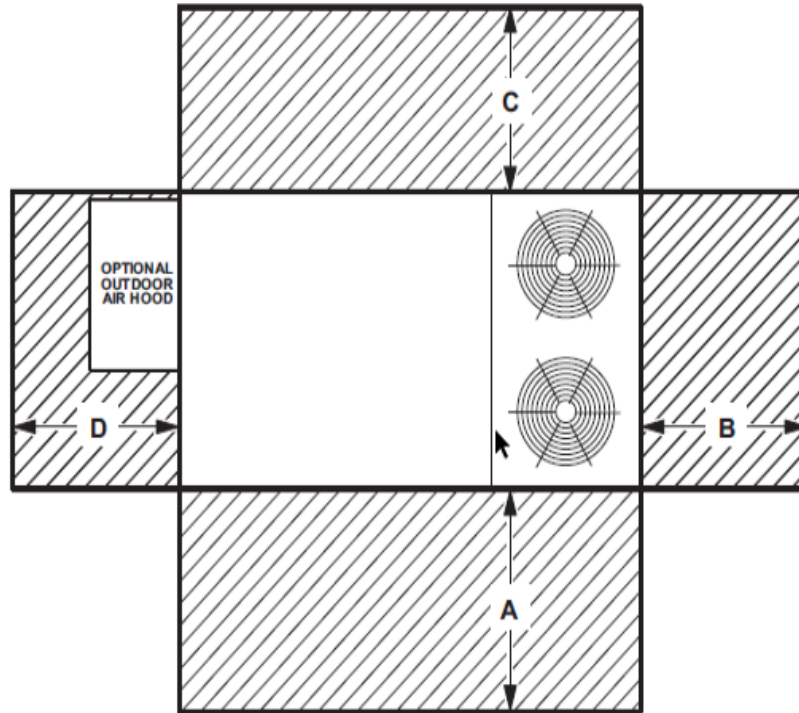

¹ Unit Clearance	A		B		C		D		Top Clearance
	in.	mm	in.	mm	in.	mm	in.	mm	
Service Clearance	60	1524	36	914	36	934	60	1524	Unobstructed
Clearance to Combustibles	36	914	1	25	1	25	1	25	
Minimum Operation Clearance	36	914	36	914	36	914	36	914	

NOTE - Entire perimeter of unit base requires support when elevated above the mounting surface.

¹ Service Clearance - Required for removal of serviceable parts.

Clearance to Combustibles - Required clearance to combustible material.

Minimum Operation Clearance - Required clearance for proper unit operation.



Lennox National Accounts Project Submittal

Tag: Miscellaneous Items

Miscellaneous Items

Tag	Catalog Number	Qty	Description
Curb Adapter RTU 4,7	COMSD	1	Curbs Plus Curb Adapter