



Feldkamp Enterprises, Inc.
 3642 Muddy Creek Rd
 Cincinnati, Ohio 45238
 P: (513) 347-4500

Project: 1338 Indian Hill New Middle School
 6845 Drake Road
 Cincinnati, Ohio 45243

Submittal #23 21 16-7.1 - AHU Coil Kits 23 21 16 - Hydronic Piping Specialties

Revision	1	Submittal Manager	Heather Wyatt (Feldkamp Enterprises, Inc.)
Status	Open	Date Created	Jun 2, 2023
Issue Date	Jun 2, 2023	Spec Section	23 21 16 - Hydronic Piping Specialties
Responsible Contractor	Kevin McGovern Associates, Inc.	Received From	Jay Fazekas (Kevin McGovern Associates, Inc.)
Received Date		Submit By	
Final Due Date	Jun 23, 2023	Lead Time	
		Cost Code	
Location		Type	Product Information
Manufacturer	Griswold		
Approvers	Heather Wyatt (Feldkamp Enterprises, Inc.), Trey Stautberg (Skanska USA Building)		
Ball in Court	Heather Wyatt (Feldkamp Enterprises, Inc.)		
Distribution	Jack Rahn (Feldkamp Enterprises, Inc.)		
Description			

Submittal Workflow

Name	Sent Date	Due Date	Returned Date	Response	Attachments
General Information Attachments					
Jay Fazekas	Jun 2, 2023	Jun 7, 2023	Jun 5, 2023	Submitted	
Heather Wyatt	Jun 5, 2023	Jun 9, 2023		Pending	
Trey Stautberg		Jun 23, 2023		Pending	

GRISWOLD CONTROLS

KEVIN MCGOVERN ASSOCIATES INC.
1711 ARLINGATE LN
COLUMBUS, OH 43228
PH: 614-481-8121 FX: -0734

DATE: JUNE 5, 2023

PROJECT: INDIAN HILLS MIDDLE SCHOOL

CONTRACTOR: FELDKAMP ENTR

ARCH / ENGR: MOTZ ENGINEERING

REPRESENTED BY: KEVIN MCGOVERN ASSOCIATES (JAY FAZEKAS, jay@kmahvac.com)

GRISWOLD COIL PACKAGE SUBMITTALS

Kevin McGovern Assoc.
 1711 Arlingate Ln
 Columbus, Ohio 43228
 (614)481-8121

GRISWOLD CONTROLS FLOW SCHEDULE

PAGE 1 OF 7				DATE		6/5/2023	
DISTRIBUTOR: KEVIN McGOVERN AND ASSOCIATES				LOCATION		COLUMBUS, OHIO	
JOB NAME INDIAN HILL MIDDLE SCHOOL				LOCATION		CINCINNATI, OHIO	
MECH ENGR: MOTZ ENGINEERING				LOCATION		CINCINNATI, OHIO	
CONTRACTOR FELDKAMP ENTR				LOCATION		CINCINNATI, OHIO	
ITEM	QTY	I.D. TAG OR LOCATION		LINE SIZE	COIL PACKAGE	FLOW (GPM)	MODEL NUMBER
1	1	VAV-1-1-1		3/4"	LA2-200	1.87	1R02B
2	1	VAV-1-1-2		3/4"	LA2-200	2.03	1R02B
3	1	VAV-1-1-3		3/4"	LA2-200	1.90	1R02B
4	1	VAV-1-1-4		3/4"	LA2-200	1.90	1R02B
5	1	VAV-1-1-5		3/4"	LA2-200	1.61	1R02B
6	1	VAV-1-1-6		3/4"	LA2-200	1.37	1R02B
7	1	VAV-1-1-7		3/4"	LA2-200	0.94	1R02B
8	1	VAV-1-1-8		3/4"	LA2-200	2.31	1R02B
9	1	VAV-1-1-9		3/4"	LA2-200	2.31	1R02B
10	1	VAV-1-1-10		3/4"	LA2-200	0.68	1R02B
11	1	VAV-1-1-11		3/4"	LA2-200	1.20	1R02B
12	1	VAV-1-1-12		3/4"	LA2-200	1.25	1R02B
13	1	VAV-1-1-13		3/4"	LA2-200	2.70	1R02B
14	1	VAV-1-1-14		3/4"	LA2-200	2.70	1R02B
15	1	VAV-1-1-15		3/4"	LA2-200	1.90	1R02B
16	1	VAV-1-1-16		3/4"	LA2-200	0.88	1R02B
17	1	VAV-1-1-17		3/4"	LA2-200	2.85	1R02B
18	1	VAV-1-1-18		3/4"	LA2-200	2.89	1R02B

Kevin McGovern Assoc.
 1711 Arlingate Ln
 Columbus, Ohio 43228
 (614)481-8121

GRISWOLD CONTROLS FLOW SCHEDULE

ITEM	QTY	I.D. TAG OR LOCATION		LINE SIZE	COIL PACKAGE	FLOW (GPM)	MODEL NUMBER
19	1	VAV-1-1-18A		3/4"	LA2-200	0.29	1R02B
20	1	VAV-1-1-19		3/4"	LA2-200	2.70	1R02B
21	1	VAV-1-1-20		3/4"	LA2-200	2.85	1R02B
22	1	VAV-1-1-21		3/4"	LA2-200	3.42	1R02B
23	1	VAV-1-1-22		3/4"	LA2-200	1.53	1R02B
24	1	VAV-1-1-23		3/4"	LA2-200	1.53	1R02B
25	1	VAV-1-1-24		3/4"	LA2-200	1.20	1R02B
26	1	VAV-1-1-25		3/4"	LA2-200	1.90	1R02B
27	1	VAV-1-1-26		3/4"	LA2-200	2.42	1R02B
28	1	VAV-1-1-27		3/4"	LA2-200	1.46	1R02B
29	1	VAV-1-1-28		3/4"	LA2-200	1.37	1R02B
30	1	VAV-1-2-1		3/4"	LA2-200	2.70	1R02B
31	1	VAV-1-2-2		3/4"	LA2-200	1..9	1R02B
32	1	VAV-1-2-3		3/4"	LA2-200	1.90	1R02B
33	1	VAV-1-2-4		3/4"	LA2-200	1.90	1R02B
34	1	VAV-1-2-5		3/4"	LA2-200	2.07	1R02B
35	1	VAV-1-2-6		3/4"	LA2-200	2.78	1R02B
36	1	VAV-1-2-7		3/4"	LA2-200	2.50	1R02B
37	1	VAV-1-2-8		3/4"	LA2-200	3.20	1R02B
38	1	VAV-1-2-9		3/4"	LA2-200	3.20	1R02B
39	1	VAV-1-2-10		3/4"	LA2-200	1.99	1R02B
40	1	VAV-1-2-11		3/4"	LA2-200	1.20	1R02B
41	1	VAV-1-2-12		3/4"	LA2-200	0.77	1R02B
42	1	VAV-1-2-13		3/4"	LA2-200	3.17	1R02B
43	1	VAV-1-2-14		3/4"	LA2-200	3.27	1R02B
44	1	VAV-1-2-15		3/4"	LA2-200	3.14	1R02B

GRISWOLD CONTROLS FLOW SCHEDULE

ITEM	QTY	I.D. TAG OR LOCATION		LINE SIZE	COIL PACKAGE	FLOW (GPM)	MODEL NUMBER
45	1	VAV-1-2-16		3/4"	LA2-200	1.90	1R02B
46	1	VAV-1-2-17		3/4"	LA2-200	2.42	1R02B
47	1	VAV-1-2-18		3/4"	LA2-200	2.42	1R02B
48	1	VAV-1-2-19		3/4"	LA2-200	2.29	1R02B
49	1	VAV-1-2-20		3/4"	LA2-200	2.77	1R02B
50	1	VAV-1-2-21		3/4"	LA2-200	2.85	1R02B
51	1	VAV-1-2-22		3/4"	LA2-200	2.59	1R02B
52	1	VAV-1-2-23		3/4"	LA2-200	2.24	1R02B
53	1	VAV-1-2-24		3/4"	LA2-200	2.24	1R02B
54	1	VAV-1-2-25		3/4"	LA2-200	2.16	1R02B
55	1	VAV-2-1-1		3/4"	LA2-200	0.94	1R02B
56	1	VAV-2-1-2		3/4"	LA2-200	1.37	1R02B
57	1	VAV-2-1-3		3/4"	LA2-200	1.55	1R02B
58	1	VAV-2-1-4		3/4"	LA2-200	2.42	1R02B
59	1	VAV-2-1-5		3/4"	LA2-200	0.94	1R02B
60	1	VAV-2-1-6		1"	LA2-200	4.98	1R12B
61	1	VAV-2-1-7		3/4"	LA2-200	1.75	1R02B
62	1	VAV-2-1-8		3/4"	LA2-200	2.72	1R02B
63	1	VAV-2-1-9		3/4"	LA2-200	1.99	1R02B
64	1	VAV-2-1-10		3/4"	LA2-200	3.01	1R02B
65	1	VAV-2-1-11		3/4"	LA2-200	0.20	1R02B
66	1	VAV-2-1-12		3/4"	LA2-200	0.53	1R02B
67	1	VAV-2-1-13		3/4"	LA2-200	0.25	1R02B
68	1	VAV-2-1-14		3/4"	LA2-200	3.56	1R02B
69	1	VAV-2-1-15		3/4"	LA2-200	0.40	1R02B
70	1	VAV-2-2-1		3/4"	LA2-200	0.40	1R02B

Kevin McGovern Assoc.
 1711 Arlingate Ln
 Columbus, Ohio 43228
 (614)481-8121

GRISWOLD CONTROLS FLOW SCHEDULE

ITEM	QTY	I.D. TAG OR LOCATION		LINE SIZE	COIL PACKAGE	FLOW (GPM)	MODEL NUMBER
71	1	VAV-2-2-2		3/4"	LA2-200	2.16	1R02B
72	1	VAV-2-2-3		3/4"	LA2-200	2.85	1R02B
73	1	VAV-2-2-4		3/4"	LA2-200	3.33	1R02B
74	1	VAV-2-2-5		3/4"	LA2-200	2.40	1R02B
75	1	VAV-2-2-6		3/4"	LA2-200	3.33	1R02B
76	1	VAV-2-2-7		3/4"	LA2-200	2.29	1R02B
77	1	VAV-2-2-8		3/4"	LA2-200	2.29	1R02B
78	1	VAV-2-2-9		3/4"	LA2-200	2.70	1R02B
79	1	VAV-2-2-10		3/4"	LA2-200	2.29	1R02B
80	1	VAV-2-2-11		3/4"	LA2-200	2.16	1R02B
81	1	VAV-2-2-12		3/4"	LA2-200	2.40	1R02B
82	1	VAV-2-2-13		3/4"	LA2-200	1.75	1R02B
83	1	VAV-2-2-14		3/4"	LA2-200	1.75	1R02B
84	1	VAV-2-2-15		3/4"	LA2-200	0.96	1R02B
85	1	VAV-2-2-16		3/4"	LA2-200	0.96	1R02B
86	1	VAV-2-2-17		3/4"	LA2-200	1.73	1R02B
87	1	VAV-3-1-1		1-1/4"	LA2-200	13.95	1R22B
88	1	VAV-3-1-2		1-1/4"	LA2-200	13.95	1R22B
89	1	VAV-3-1-3		3/4"	LA2-200	1.20	1R02B
90	1	VAV-3-1-4		3/4"	LA2-200	1.37	1R02B
91	1	VAV-3-1-5		3/4"	LA2-200	0.68	1R02B
92	1	VAV-3-1-6		3/4"	LA2-200	1.75	1R02B
93	1	VAV-3-1-7		3/4"	LA2-200	2.07	1R02B
94	1	VAV-3-1-8		3/4"	LA2-200	0.69	1R02B
95	1	VAV-3-1-9		3/4"	LA2-200	0.69	1R02B
96	1	VAV-3-1-10B		3/4"	LA2-200	1.75	1R02B

GRISWOLD CONTROLS FLOW SCHEDULE

ITEM	QTY	I.D. TAG OR LOCATION		LINE SIZE	COIL PACKAGE	FLOW (GPM)	MODEL NUMBER
97	1	VAV-3-1-10		3/4"	LA2-200	1.20	1R02B
98	1	VAV-3-1-11		3/4"	LA2-200	1.37	1R02B
99	1	VAV-3-1-12		3/4"	LA2-200	1.19	1R02B
100	1	VAV-3-1-13		1"	LA2-200	6.84	1R12B
101	1	VAV-3-1-14		1"	LA2-200	7.89	1R12B
102	1	VAV-3-1-15		3/4"	LA2-200	0.94	1R02B
102	1	VAV-4-1-1		3/4"	LA2-200	1.19	1R02B
103	1	VAV-4-1-2		3/4"	LA2-200	0.94	1R02B
104	1	VAV-4-1-3		3/4"	LA2-200	1.19	1R02B
105	1	VAV-4-1-4		3/4"	LA2-200	3.32	1R02B
106	1	VAV-4-1-5		3/4"	LA2-200	0.69	1R02B
107	1	VAV-4-1-6		3/4"	LA2-200	0.88	1R02B
108	1	VAV-4-1-7		3/4"	LA2-200	0.68	1R02B
109	1	VAV-4-1-8		3/4"	LA2-200	0.68	1R02B
110	1	VAV-4-1-9		3/4"	LA2-200	1.87	1R02B
111	1	VAV-4-1-10		3/4"	LA2-200	0.68	1R02B
112	1	VAV-4-1-11		3/4"	LA2-200	0.69	1R02B
113	1	VAV-4-1-12		3/4"	LA2-200	0.69	1R02B
114	1	VAV-4-1-13		3/4"	LA2-200	1.19	1R02B
115	1	VAV-4-1-14		3/4"	LA2-200	1.19	1R02B
116	1	VAV-4-1-15		3/4"	LA2-200	1.99	1R02B
117	1	VAV-4-1-16		3/4"	LA2-200	3.32	1R02B
118	1	VAV-4-1-17		3/4"	LA2-200	1.55	1R02B
119	1	VAV-4-1-18		3/4"	LA2-200	1.20	1R02B
120	1	VAV-4-1-19		3/4"	LA2-200	0.69	1R02B
121	1	VAV-4-1-20		3/4"	LA2-200	0.30	1R02B

GRISWOLD CONTROLS FLOW SCHEDULE

ITEM	QTY	I.D. TAG OR LOCATION		LINE SIZE	COIL PACKAGE	FLOW (GPM)	MODEL NUMBER
122	1	VAV-4-1-21		3/4"	LA2-200	3.32	1R02B
123	1	VAV-4-1-22		3/4"	LA2-200	3.32	1R02B
124	1	VAV-4-1-23		3/4"	LA2-200	3.32	1R02B
125	1	VAV-4-1-24		3/4"	LA2-200	3.32	1R02B
126	1	VAV-4-1-25		3/4"	LA2-200	3.32	1R02B
127	1	VAV-4-1-26		3/4"	LA2-200	0.68	1R02B
128	1	VAV-4-1-27		3/4"	LA2-200	1.99	1R02B
129	1	VAV-4-1-28		3/4"	LA2-200	3.02	1R02B
130	1	VAV-4-1-29		3/4"	LA2-200	0.68	1R02B
131	1	VAV-4-1-30		3/4"	LA2-200	0.69	1R02B
132	1	VAV-4-1-31		3/4"	LA2-200	0.11	1R02B
133	1	VAV-4-1-32		3/4"	LA2-200	0.11	1R02B
134	1	VAV-4-1-33		3/4"	LA2-200	0.11	1R02B
135	1	VAV-4-1-34		3/4"	LA2-200	2.16	1R02B
136	1	VAV-4-1-35		3/4"	LA2-200	2.24	1R02B
137	1	VAV-4-1-36		3/4"	LA2-200	1.99	1R02B
138	1	VAV-4-1-37		3/4"	LA2-200	0.68	1R02B
139	1	VAV-4-1-38		3/4"	LA2-200	0.30	1R02B
140	1	FPVAV-1-1		3/4"	LA2-200	0.40	1R02B
141	1	FPVAV-1-2		3/4"	LA2-200	2.60	1R02B
142	1	FPVAV-1-3		3/4"	LA2-200	2.60	1R02B
143	1	UH-1		3/4"	LA2-200	2.50	1R02B
144	1	AHU-M-1 HTG	417	4"	LM2-256 (3) COILS	174.00	3QFPY
145	1	AHU-M-1 CLG	980	6"	LM2-256 (3) COILS	488.00	3QFRY
146	1	AHU-M-2 HTG	417	4"	LM2-256 (3) COILS	135.00	3QFPY
147	1	AHU-M-2 CLG	980	6"	LM2-256 (3) COILS	357.00	3QFRY

COIL PIPING PACKAGE # LA2-200

**GRISWOLD ISOLATOR "R" COIL
PACKAGE**

JOB: INDIAN HILLS MS

CONTRACTOR: FELDKAMP MECH

AUTOMATIC FLOW CONTROL VALVE

AVAILABLE SIZES: 1/2", 3/4", 1", 1-1/4", 1-1/2", 2", 2-1/2", 3"

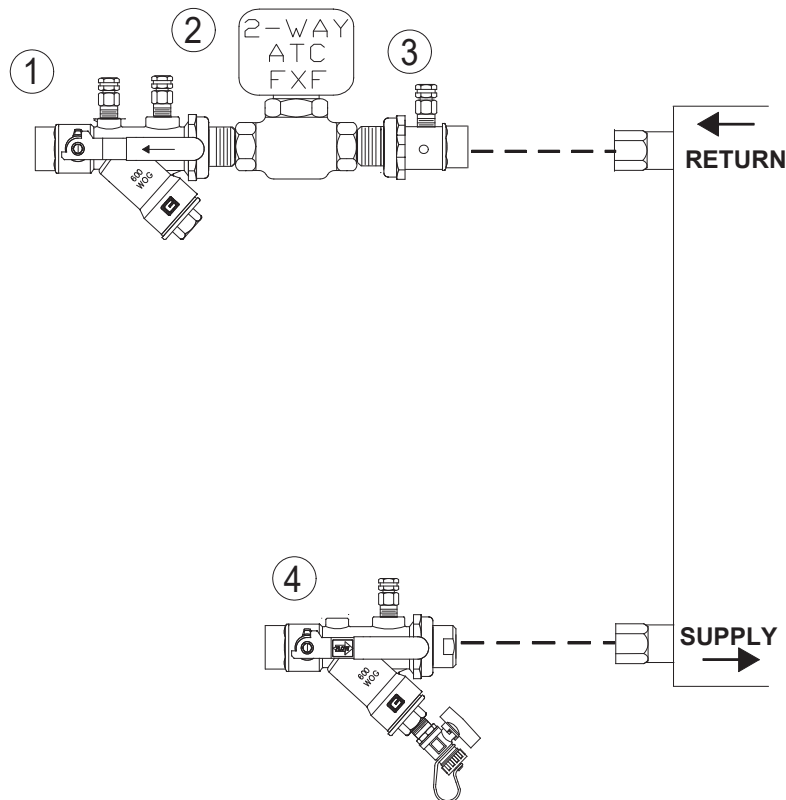

1. GRISWOLD ISOLATOR "R": Automatic flow control valve with dual P.T. plugs, shut-off, manual air vent and union
2. 2-WAY ATC VALVE: SUPPLIED BY OTHERS
3. GRISWOLD ISOLATOR U: Union with P.T. plug and manual air vent
4. GRISWOLD ISOLATOR S: Y-strainer with shut-off, P.T. plug, union, manual air vent and drain valve with hose bib

**FOR ADDITIONAL INFO: KEVIN McGOVERN ASSOCIATES
4245 DIPLOMACY DR
COLUMBUS, OHIO 43228
TEL: 1-614-481-8121
FAX: 1-614-481-0734**

**NOT FOR CONSTRUCTION
REFERENCE ONLY**

COIL PIPING PACKAGE # LM2-256

**GRISWOLD QUICKSET COIL
PACKAGE**

JOB: INDIAN HILLS MS

CONTRACTOR: FELDKAMP MECH

MANUAL FLOW CONTROL VALVE

AVAILABLE SIZES: 2-1/2", 3", 4", 6"

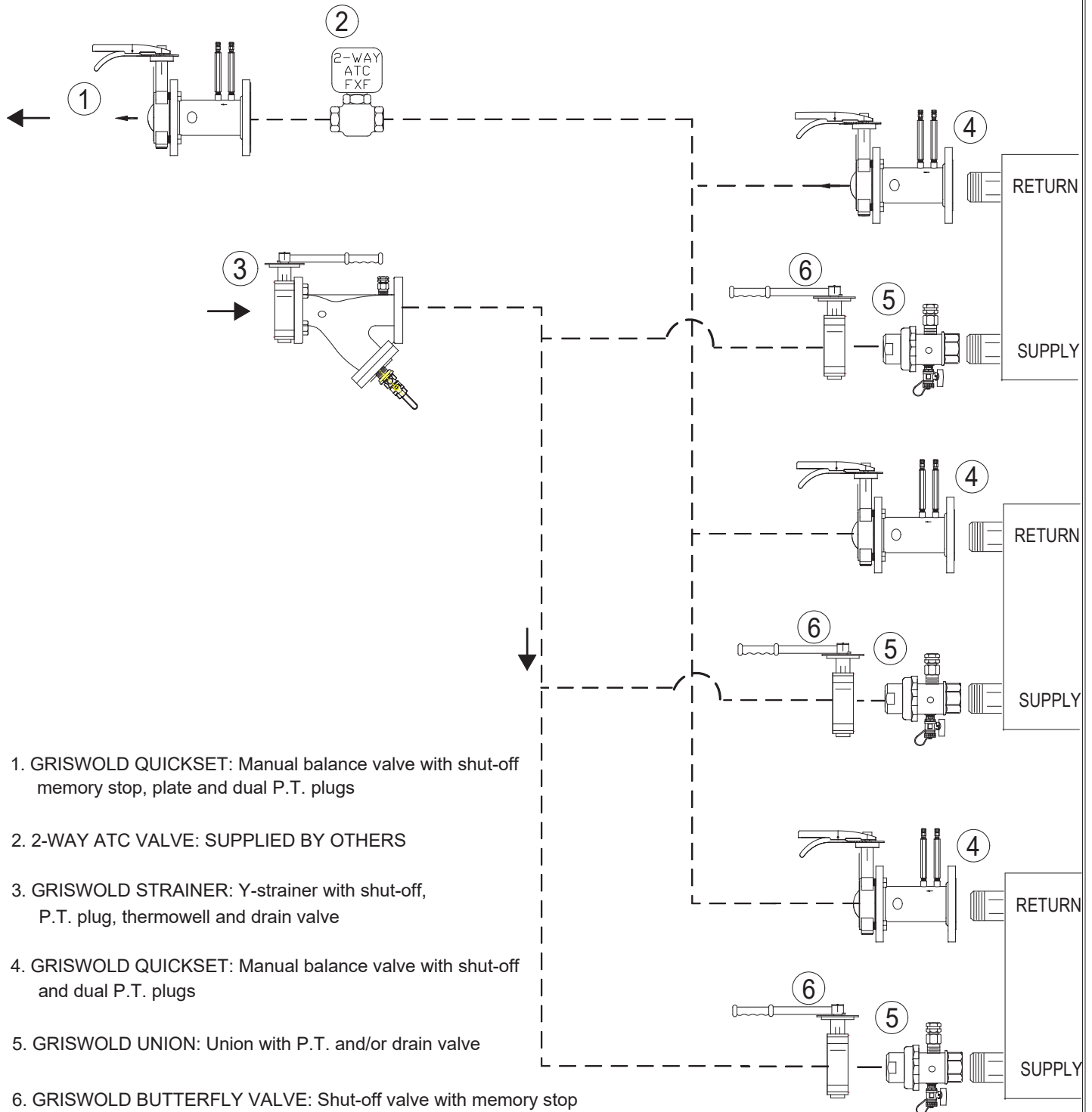

**FOR ADDITIONAL INFO: KEVIN McGOVERN ASSOCIATES
4245 DIPLOMACY DR
COLUMBUS, OHIO 43228
TEL: 1-614-481-8121
FAX: 1-614-481-0734**

**NOT FOR CONSTRUCTION
REFERENCE ONLY**

COIL PIPING PACKAGE #LM2-266

JOB: INDIAN HILLS MS

GRISWOLD QUICKSET COIL PACKAGE

CONTRACTOR:

FELDKAMP MECH

MANUAL FLOW CONTROL VALVE

AVAILABLE SIZES: 1/2", 3/4", 1", 1-1/4", 2", 2-1/2"

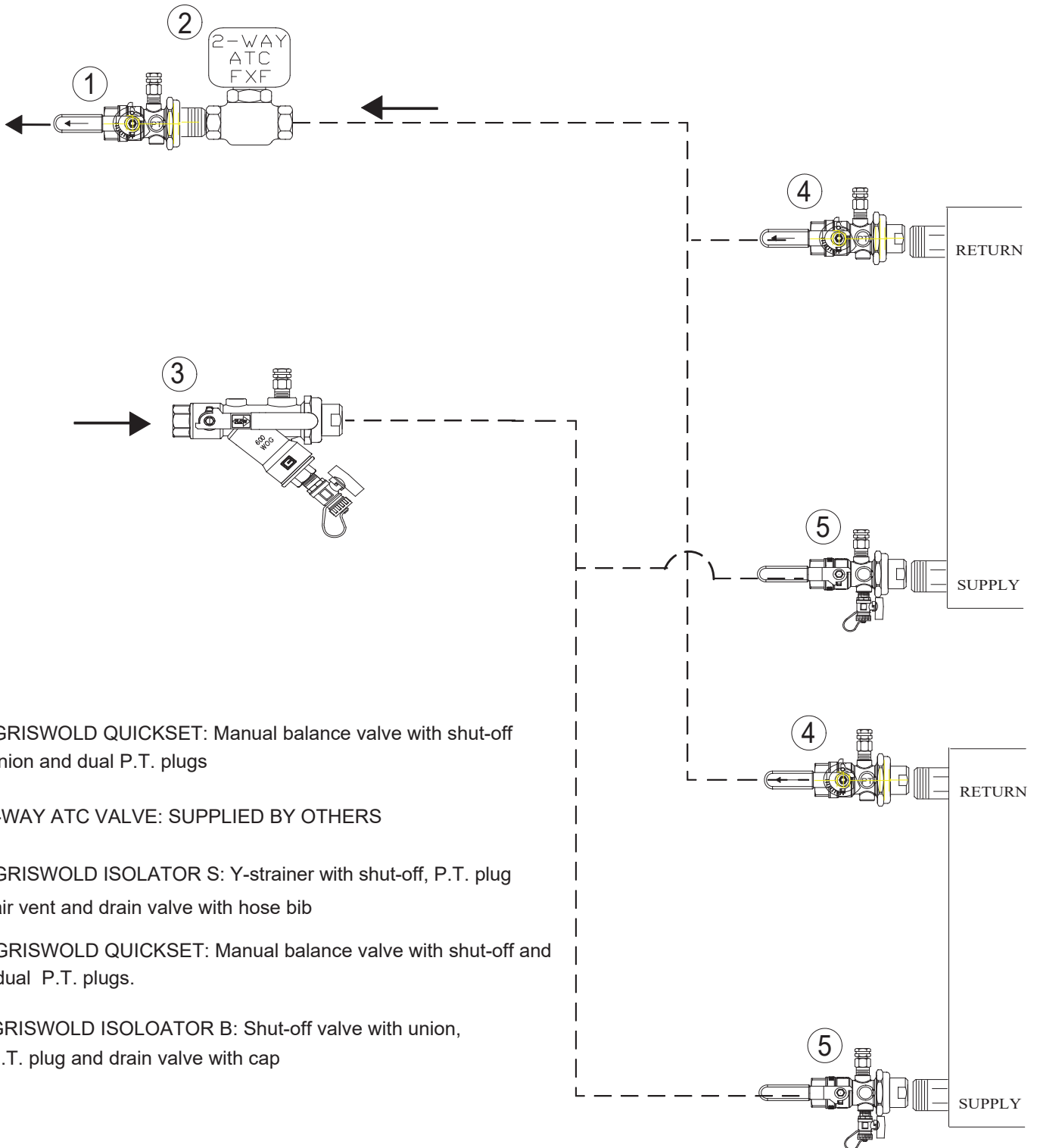

FOR ADDITIONAL INFO:

**KEVIN McGOVERN ASSOCIATES
1711 ARLINGATE LN
COLUMBUS, OHIO 43228
TEL: 1-614-481-8121
FAX: 1-614-481-0734**

**NOT FOR CONSTRUCTION
REFERENCE ONLY**

ACCESSIBLE CARTRIDGE



SPECIFICATIONS

- PSI/Temperature Rating:** 1/2"-1-1/2": 600 WOG 400 PSI / 250° F
1-1/2"L-3": 400 WOG 275 PSI / 250° F
- Cartridge:** AISI Type 304 stainless steel
AISI Type 17-7 PH stainless steel spring
- Body Material:** 1/2"-1-1/2": Forged brass ASTM B283-06
1-1/2"L-3": Cast brass
- End Connections:** Brass – NPT, Sweat or QuickPress¹
- Ball Valve Seals:** Teflon
- Union Seal:** EPDM O-Ring
- Body Tappings²:** Two Combination P/T Test Valve and Manual Air Vent (CPTA)
- Ball Valve:** Nickel-plated brass ball
Optional: Stainless Steel ball
- Field Repairable Stem:** Dual Teflon seals and EPDM O-ring

1/2" – 1-1/2" Housing

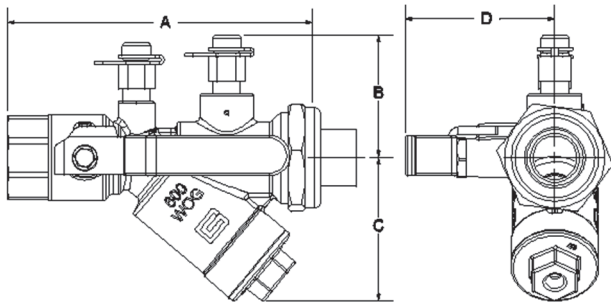

1-1/2"L – 3" Housing

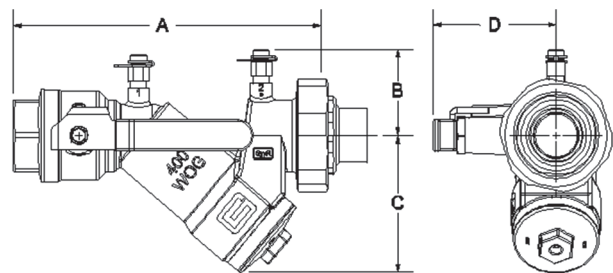

DIMENSIONS & WEIGHTS (NOMINAL)

All dimensions are for planning purposes only and may change without notice.

SIZE	A - FIXED END CONNECTION		UNION END CONNECTION ³						B	C	D ⁴	Cv ⁵	WEIGHT (LBS.)	
	FNPT	SWT	FNPT		MNPT		SWT							
1/2"	3.9	3.8												
3/4"	3.9	4.0	1/2":1.0	3/4":N/A ⁶	1/2":1.0	3/4":1.2	3/8",1/2":0.8	3/4":1.1	1.9	2.9	0.5,1.5 2.2	2.3	1.0	
1/2"L	5.3	5.5												
3/4"L	5.4	5.4	1/2",3/4":1.0	1":N/A ⁶	1/2"-3/4":1.0	1":1.4	3/8",3/4":1.0	1/2":0.7	1":1.3	2.2	3.6	1.6, 2.6, 3.2	10.9	2.3
1"	5.4	5.6										2.6,3.2		
1"L	8.0	8.2												
1-1/4"	7.6	7.7	1",1-1/4",1-1/2":1.7		1",1-1/4",1-1/2":1.7 ⁷		1",1-1/4":1.7	1-1/2":1.4	2.5	3.1	3.1, 3.7	28.5	5.0	
1-1/2"	7.5	7.9												
1-1/2"L	9.4	9.6	1-1/4", 1-1/2":1.6	2": N/A ⁶	1",1-1/4":1.8	1-1/2", 2":1.6	1-1/4",2":1.6	1-1/2":1.7	2.6	3.7	3.7, 4.3	40	8.8	
2"	9.3	9.8												
2"L	10.9	11.2	2": 2.5		2": 1.6		2": 1.6							
2-1/2"	12.1	N/A	N/A ⁸						2.9	4.0	4.0, 4.6	75	13.6	
3"	12.3	N/A	N/A ⁸											

For QuickPress connections add 3.1" (1/2", 1/2"L) 3.6" (3/4", 3/4"L), 4.1" (1") to the FNPT length (A) listed for a valve.

NOTES

- ¹ QuickPress is available on 1/2" to 1" valves. Connections are compatible with popular press tools and are rated for maximum 200 PSI.
- ² Body Tappings for accessories are a leak proof metal to metal seal and do not require pipe dope or tape. Tape or dope should not be used.
- ³ For overall length, add union end connection length to body length.
- ⁴ Space Saver handle standard on 1/2"-3/4" valves. Standard handle on 1" to 3" valves and 1-1/2" extended handle in 1/2" to 3" is compatible with 1-1/2" insulation. Largest extended handle is compatible with 2" insulation.
- ⁵ Cv's are based on housing without cartridge.
- ⁶ Tailpiece is not available for this size. Male tailpiece used with ASME B16.15 Class 125 coupling.
- ⁷ 1-1/4"-1-1/2" valves can also take 1/2"-3/4" MNPT tailpieces.
- ⁸ 2-1/2" and 3" Valves are fixed end by fixed end connection. Union connection is not available.

MODEL NUMBER SELECTION⁹

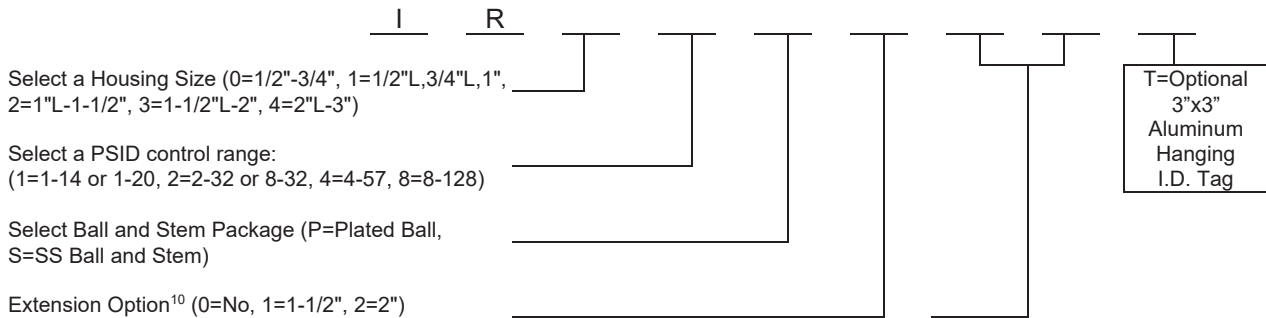

Valve	FIXED END OR UNION END ¹¹ (No Union Tailpiece=Z)			UNION END ONLY ¹¹
	Female Threaded	Female Sweat	QuickPress	Male Threaded
IR0	1/2"=E, 3/4"=F ¹²	3/8"=K ¹³ , 1/2"=L, 3/4"=M	1/2"=2, 3/4"=3	1/2"=H, 3/4"=I
IR1	1/2"=E, 3/4"=F, 1"=G ¹²	3/8"=K ¹³ , 1/2"=L, 3/4"=M, 1"=N	1/2"=2, 3/4"=3, 1"=1	1/2"=H, 3/4"=I, 1"=J
IR2	1"=G, 1-1/4"=P, 1-1/2"=Q	1"=N, 1-1/4"=K, 1-1/2"=W	N/A	1/2"=H, 3/4"=I, 1"=J, 1-1/4"=S, 1-1/2"=T
IR3	1-1/4"=P ¹³ , 1-1/2"=Q, 2"=R ¹²	1-1/4"=K ¹³ , 1-1/2"=W, 2"=Y	N/A	1-1/4"=S, 1-1/2"=T, 2"=U
IR4 ¹¹ (Union)	2"=L	2"=Y	N/A	1-1/4"=S, 1-1/2"=T, 2"=U
IR4 ¹¹ (Fixed End)	2"=L, 2-1/2"=M, 3"=N	N/A	N/A	N/A

FLOW RATES (+/-5%)

SIZE	MODEL NO.	HEAD LOSS IN FEET ¹⁴	PSID RANGE ¹⁵	GPM					
				MIN.	INCREMENT	MAX			
1/2", 3/4"	IR02	7.4	2-32	0.25, 0.33, 0.50, 0.60, 0.75, 0.85, 1.00, 1.25, 1.50, 2.00, 2.50, 3.00					
	IR04	13.4	4-57	0.50, 1.00, 1.50, 2.00, 2.50, 3.00					
1/2"L, 3/4", 1"	IR11	3.5	1-14	0.33, 0.50, 0.67, 1.00, 1.33, 1.67, 2.00, 2.33, 2.67, 3.33, 4.00, 4.67, 5.00					
	IR12	7.4	2-32	0.55, 0.75, 1.00, 1.25, 1.50, 1.75, 2.00, 2.25, 2.50, 2.75, 3.00, 3.50, 4.00, 5.00, 6.00, 7.00, 8.00					
	IR14	13.4	4-57	0.75, 1.00, 1.33, 2.00, 2.67, 3.33, 4.00, 4.67, 5.33, 6.67, 8.00, 9.33, 10.00, 11.00					
	IR18	30.0	8-128	1.10, 1.50, 2.00, 3.00, 4.00, 5.00, 6.00, 7.00, 8.00, 10.0, 12.0, 14.0, 16.0					
1"L, 1-1/4", 1-1/2"	IR21	3.5	1-14	5.33, 6.0, 6.67, 7.33, 8.0, 8.67, 9.33, 10.0, 10.67, 11.33, 12.0, 12.67, 13.33, 14.0, 14.67					
	IR22	7.4	2-32	8.0, 9.0, 10.0, 11.0, 12.0, 13.0, 14.0, 15.0, 16.0, 17.0, 18.0, 19.0, 20.0, 21.0, 22.0					
	IR24	13.4	4-57	10.67, 12.00, 13.33, 14.67, 16.00, 17.33, 18.67, 20.00, 21.33, 22.67, 24.00, 25.33, 26.67, 28.00, 29.33					
1-1/2"L - 2"	IR28	30.0	8-128	16.0, 18.0, 20.0, 22.0, 24.0, 26.0, 28.0, 30.0, 32.0, 34.0, 36.0, 38.0, 40.0, 42.0, 44.0					
	IR31	3.5	1-14	12, 14, 16, 18, 20, 22, 24, 26, 28, 30, 32, 34, 36, 38					
	IR32	7.4	2-32	18, 21, 24, 27, 30, 33, 36, 39, 42, 45, 48, 51, 54, 57					
	IR34	13.4	4-57	24, 28, 32, 36, 40, 44, 48, 52, 56, 60, 64, 68, 72, 76					
2"L, 2-1/2", 3"	IR38	30.0	8-128	36, 42, 48, 54, 60, 66, 72, 78, 84, 90, 96, 102, 108, 114					
	IR41	3.5	1-20	14.0	2.0	60	9.2	4-20	90, 110, 130
	IR42	7.4	2-32	17.5	2.5	75	18.4	8-32	110, 135, 160
	IR44	13.4	4-57	23.33	3.33	100	NONE		
	IR48	30.0	8-128	35.0	5.0	150	NONE		

NOTES

- ⁹ Model no. and flow rate are indicated on label affixed to body.
- ¹⁰ Extension Option includes handle cover and accessory extensions for either 1-1/2" or 2" Insulation.
- ¹¹ Select the Fixed End First and the Union End Second. For 2-1/2" and 3" size select a 2nd fixed end instead of a union end.
- ¹² Tailpiece is not available for this size. Male tailpiece used with ASME B16.15 Class 125 coupling.
- ¹³ Fixed end not available for this size. Union tailpiece only.
- ¹⁴ Head Loss in Feet is provided for pump head calculations. (1 PSI = 2.307 Feet of Water)
- ¹⁵ Systems with entrained air and fluid velocities less than 4FPS are susceptible to noise when using the 2-32 cartridge. If your system has entrained air and flowrates less than 2GPM please consider using the 4-57 cartridge.

SPECIFICATIONS



PSI/Temperature Rating: 600 WOG 400 PSI / 250°F
Flow Elements: Venturi: Brass
Body Material: Forged Brass ASTM B283-06
End Connections: Brass – NPT, Sweat or QuickPress¹
Ball Valve Seals: Teflon
Union Seal: EPDM O-ring
Ball Valve: Nickel-plated brass ball, full port
 Optional: Stainless steel ball
Body Tappings²: Two Combination P/T Test Valve and Manual Air Vent (CPTA)
Field Repairable Stem: Dual Teflon seals and EPDM O-ring
Handle: Memory Stop with graduated markings
Installation: Straight sections of piping upstream and downstream of the QuickSet aren't necessary for proper operation
Options: Extension Option³

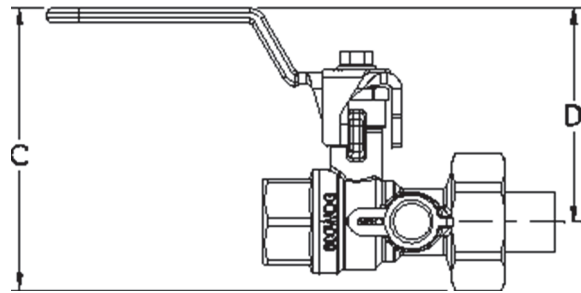
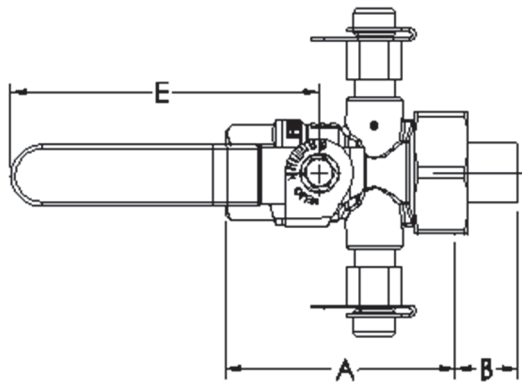

DIMENSIONS & WEIGHTS (NOMINAL)

All dimensions are for planning purposes only and may change without notice.

SIZE	A - FIXED END CONNECTION		B - UNION END CONNECTION ⁴						C	D ⁵	E	WEIGHT (LBS.)		
	FNPT	SWT	FNPT		MNPT		SWT							
1/2"	2.6	2.5	1/2":1.0	3/4":N/A ⁶	1/2":1.0	3/4":1.2	3/8",1/2":0.8		3/4":1.1	3.0	1.0, 1.5, 2.2	3.7	0.7	
3/4"	2.6	3.2					3/8",3/4":1.0							1":1.3
3/4"L	3.0	3.1	1/2",3/4":1.0	1":N/A ⁶	1/2"-3/4":1.0	1":1.4	3/8",3/4":1.0		1":1.3	3.8	2.1, 2.6, 3.2	3.7	1.0	
1"	3.2	3.4					1",1-1/4",1-1/2":1.7							1":1.7
1-1/4"	3.9	4.1	1",1-1/4",1-1/2":1.7		1",1-1/4",1-1/2":1.7		1",1-1/4":1.7		1-1/2":1.4		4.0	2.9, 3.5	5.0	1.5
1-1/2"	4.4	4.6	1",1-1/4",1-1/2":1.7		1",1-1/4",1-1/2":1.7		1",1-1/4":1.7		1-1/2":1.4					
2"	5.1	5.5	1-1/2":1.6	2": N/A ⁶	1-1/2", 2":1.6		1-1/2":1.7		2":1.6		5.3	3.5, 4.1	5.5	4.5
			1-1/2":1.6	2": N/A ⁶	1-1/2", 2":1.6		1-1/2":1.7		2":1.6		5.3	4.0, 4.6	5.5	6.9

For QuickPress connections add 3.1" (1/2", 1/2"L) 3.6" (3/4", 3/4"L), 4.1" (1") to the FNPT length (A) listed for a valve.

NOTES

- ¹ QuickPress is available on 1/2" to 1" valves. Connections are compatible with popular press tools and are rated for maximum 200 PSI.
- ² Body Tappings for accessories are a leak proof metal to metal seal and do not require pipe dope or tape. Tape or dope should not be used.
- ³ Extension Option includes handle cover and accessory extensions for either 1-1/2" or 2" insulation.
- ⁴ For overall length, add union end connection length to body length.
- ⁵ Space Saver handle standard on 1/2"-3/4"L valves. Standard handle on 1" to 2" valves and 1-1/2" extended handle in 1/2" to 2" is compatible with 1-1/2" insulation. Largest extended handle is compatible with 2" insulation.
- ⁶ Tailpiece is not available for this size. Male tailpiece used with coupling.

FLOW RATES (+/-1%⁷)

OUTLET SIZE	MODEL NO.	FLOW GPM ⁽⁸⁾ AT 4 FT/SEC	Cv ⁽⁹⁾	GPM RANGE FOR 5"-100" W.C. ΔP (SET W/100" GAUGE)	GPM RANGE FOR 5"-300" W.C. ΔP (SET W/300" GAUGE)
1/2", 3/4"	QS0	3.8	A=0.39	0.15 – 0.67	0.15 – 1.16
			B=1.1	0.3 – 1.4	0.3 – 2.4
			C=2.5	0.6 – 2.8	0.6 – 4.6
			D=4.2	1.2 – 5.4	1.2 – 9.4
3/4"L	QS1	6.7	B=0.9	0.3 – 1.4	0.3 – 2.5
			C=1.9	0.6 – 2.8	0.6 – 4.9
			D=3.9	1.3 – 5.6	1.3 – 9.7
			E=7.0	2.6 – 11.5	2.6 – 19.9
1"	QS1	10.8	C=1.8	0.6 – 2.8	0.6 – 5.0
			D=3.8	1.3 – 5.6	1.3 – 9.7
			F=7.6	2.6 – 11.5	2.6 – 19.9
			G=12.2	3.9 – 17.3	3.9 – 30.0
1-1/4"	QS2	18.7	H=10.0	3.4 – 15.0	3.4 – 26.2
			I=21.8	7.2 – 32.3	7.2 – 55.9
1-1/2"	QS2	25.4	J=22.1	7.4 – 33.0	7.4 – 57.2
2"	QS3	41.9	N=54.7	13.9 – 62.0	13.9 – 107.4
			M=65.2 ¹⁰	21.6 – 96.5	21.6 – 167.1
			P=105.2	21.6 – 96.5	21.6 – 167.1

MODEL NUMBER SELECTION

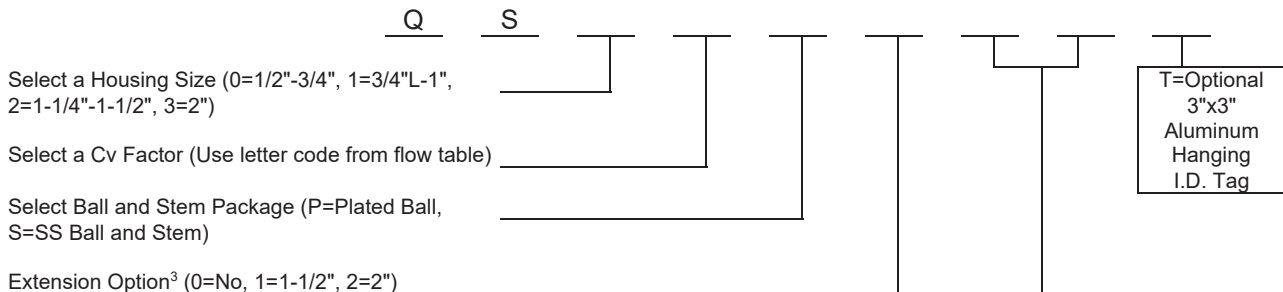

Valve	FIXED END OR UNION END ¹¹ (No Union Tailpiece=Z)			UNION END ONLY ¹¹
	Female Threaded	Female Sweat	QuickPress	Male Threaded
QS0	1/2"=E, 3/4"=F ¹²	3/8"=K ^{13/14} , 1/2"=L, 3/4"=M	1/2"=2 ¹⁴ , 3/4"=3	1/2"=H, 3/4"=I
QS1	1/2"=E ¹⁴ , 3/4"=F, 1"=G ¹²	3/8"=K ^{13/14} , 1/2"=L ^{13/14} , 3/4"=M, 1"=N	1/2"=2 ¹⁴ , 3/4"=3, 1"=1	1/2"=H ¹⁴ , 3/4"=I, 1"=J
QS2 (1-1/4")	1"=G ¹³ , 1-1/4"=P, 1-1/2"=Q	1"=N ¹³ , 1-1/4"=K, 1-1/2"=W	N/A	1/2"=H ¹⁴ , 3/4"=I ¹⁴ , 1"=J, 1-1/4"=S, 1-1/2"=T
QS2 (1-1/2")	1"=G ^{13/14} , 1-1/4"=P, 1-1/2"=Q	1"=N ^{13/14} , 1-1/4"=K, 1-1/2"=W	N/A	1"=J ¹⁴ , 1-1/4"=S, 1-1/2"=T
QS3 (2")	1-1/2"=Q ¹³ , 2"=R ¹²	1-1/2"=W ¹³ , 2"=Y	N/A	1-1/2"=T, 2"=U

Size reductions to the ATC (tailpiece side) of more than two line sizes may affect pressure signal of venturi depending on ATC configuration.

NOTES

- ⁷ Accuracy is for venturi portion of valve only. Pressure readability is dependent on accuracy of gauge and system pressure stability.
- ⁸ The generally accepted upper limit as recommended by ASHRAE to prevent pipe noise is 4 ft/sec.
- ⁹ Cv's are used to calculate the permanent pressure drop. $PSID=(Flow/Cv)^2$. Use the Flow Curve to set valve or for flow measurement.
- ¹⁰ 65.2 Cv includes an optimizer insert in the ball.
- ¹¹ Select the Fixed End First and the Union End Second.
- ¹² Tailpiece is not available for this size. Male tailpiece used with coupling.
- ¹³ Fixed end not available for this size. Union tailpiece only.
- ¹⁴ This tailpiece has Cv limitations. 3/8" tailpiece is not compatible with Cv of 4.2, 7.0, 7.6, 12.2; 1/2" tailpiece is not compatible with Cv of 12.2, 21.8, 22.1, 54.7; 3/4" tailpiece is not compatible with Cv of 21.8, 22.1, 54.7; 1" tailpiece is not compatible with Cv of 54.7 or 105.2; 1-1/4" tailpiece is not compatible with Cv of 105.2.

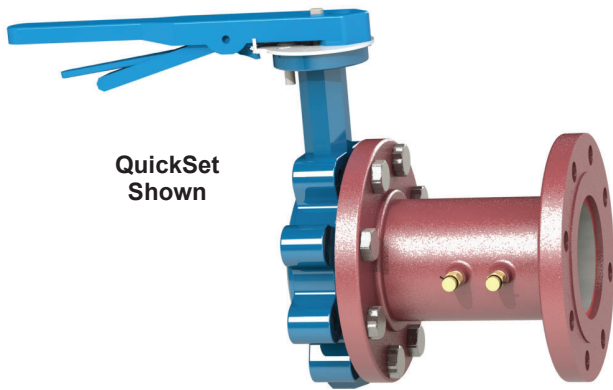

QuickSet Shown

SPECIFICATIONS:

PSI/Temperature Rating
Metering Station: 240 PSI/275° F
QuickSet: 200 PSI (14"-18": 150 PSI) /275° F
Low Loss Venturi: Carbon Steel with Piezo-Ring to average low signal pickup.
Body Material: Carbon Steel SA-53 Grade B.
Butterfly Valve¹: Bronze disk, S.S. Stem
End Connections: Steel flanges ANSI B16.5 CL 150
Body Tappings: 1/4" NPT with Brass P/T test valves
Optional Accessory Ports: Port 1: 1/4" for Air Vent
 Port 2: 3/4" for Thermowell
 Port 3: 1/2" for Drain Valve
Installation: No straight-run pipe is necessary for normal operation. Consult chart (F-4439) for exact Flow Constant and Permanent Pressure Drop calculations.

QuickSet (2-1/2"-6")

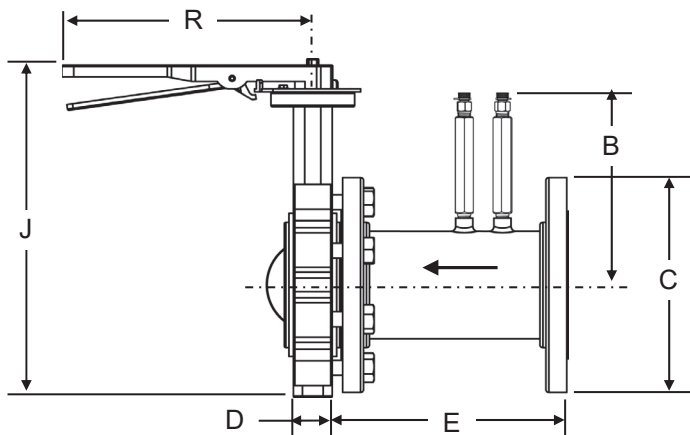

QuickSet (8"-18")

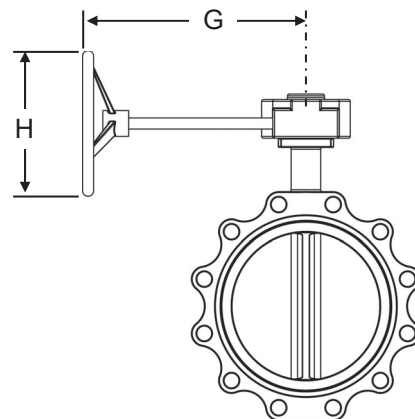

DIMENSIONS & WEIGHTS FOR QUICKSET (NOMINAL)

All dimensions are for planning purposes only and may change without notice.

LINE SIZE	B	C	D	E	G	H	J	R	WEIGHT (LBS.)	
									W/ HANDLE	W/GEAR WHEEL
2-1/2"	7.3	7.0	1.8	6.3	N/A	N/A	11.6	10.5	32	N/A
3"	7.6	7.5	1.8	6.8	N/A	N/A	12.1	10.5	35	N/A
4"	8.0	9.0	2.0	8.4	N/A	N/A	13.6	10.5	52	N/A
5"	8.6	10.0	2.1	10.3	N/A	N/A	14.6	10.5	77	N/A
6"	9.1	11.0	2.3	11.8	N/A	N/A	15.6	10.5	91	N/A
8"	10.1	13.5	2.4	15.3	N/A	12.0	18.9	N/A	N/A	170
10"	11.2	16.0	2.6	18.3	9.5	12.0	21.3	N/A	N/A	258
12"	12.2	19.0	3.0	21.8	9.5	12.0	24.6	N/A	N/A	362
14"	12.8	21.0	3.0	24.3	9.5	12.0	26.8	N/A	N/A	464
16"	13.8	23.5	4.0	27.8	15.0	16.0	30.0	N/A	N/A	630
18"	14.8	25.0	4.5	32.0	15.0	16.0	31.6	N/A	N/A	743

NOTES

¹ Butterfly valve is standard on QuickSet only.

FLOW RATES (+/-1%²)

LINE SIZE	Cv Metering Station ³	Cv QuickSet ³	Cv Metering Station with Accessory ³	Cv QuickSet with Accessory ³	GPM RANGE FOR 5-100" ⁴ W.C. ΔP (SET W/100" GAUGE)	GPM RANGE FOR 5-300" W.C. ΔP (SET W/300" GAUGE)	Turn Down Ratio
2-1/2"	171	135	169	134	19 – 87	19 – 151	7.9
3"	269	201	242	189	32 - 147	32 – 255	7.9
4"	580	417	506	387	58 – 260	58 – 451	7.8
5"	800	630	680	566	80 – 372	80 – 645	8.1
6"	1250	980	900	782	140 – 624	140 – 1075	7.7
8"	2100	1745	1800	1561	260 – 1180	260 – 2045	7.8
10"	4000	3201	3900	3149	375 – 1610	375 – 2790	7.4
12"	5700	4690	4930	4232	600 – 2790	600 – 4820	8.0
14"	7300	6225	6800	5906	775 – 3420	775 – 5940	7.7
16"	9600	8283	8900	7821	1250 – 5525	1250 – 9575	7.7
18"	14500	12057	13000	11153	1650 – 7405	1650 – 12830	7.8
20" ⁵	26400	19950	N/A	N/A	2246 – 10071	22460 – 17448	7.7

MODEL NUMBER SELECTION

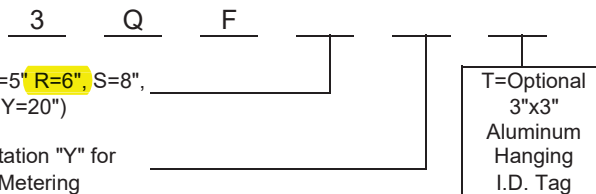

Select a Size (M=2.5", N=3", P=4", Q=5", R=6", S=8", T=10", U=12", V=14", W=16", X=18", Y=20")

Select Valve Style ("0" for Metering Station "Y" for QuickSet with Butterfly Valve, "A" for Metering Station with Accessory Port "B" for QuickSet with Accessory Port with Butterfly Valve)

NOTES

² Accuracy is for venturi portion of valve only. Pressure readability is dependent on accuracy of gauge and system pressure stability.
³ Cv's are used to calculate permanent pressure drop. PSID=(Flow/Cv)². Consult chart F-4439 Smart Phone app for flow measurement.
⁴ Not all gages/meters can accurately show a 5" signal. Readability is dependent on quality of the meter. Digital gages can read below 1".
⁵ 20" is only available as a Metering Station.

This specification © 2021 Griswold Controls

1700 Barranca Parkway, Irvine, CA 92606
 (949) 559-6000 Fax (949) 559-6088
 www.GriswoldControls.com



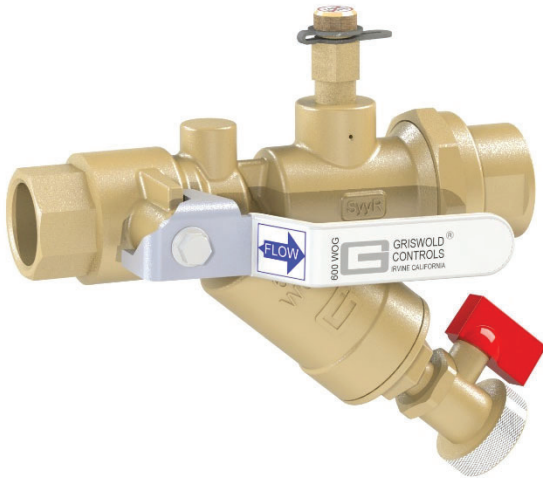

SPECIFICATIONS

- PSI/Temperature Rating:** 1/2"-1-1/2": 600 WOG 400 PSI / 250° F
1-1/2"L-3": 400 WOG 275 PSI / 250° F
- Body Material:** 1/2"-1-1/2": Forged Brass ASTM B283-06
1-1/2"L-3": Cast brass
- End Connections:** Brass – NPT, Sweat, QuickPress¹, Grooved²
- Ball Valve Seals:** Teflon
- Union Seal:** EPDM O-Ring
- Body Tappings³:** (3) Bosses for CPTAs and Drain Valve
- Ball Valve:** Nickel-plated brass ball
Optional: Stainless Steel ball
- Field Repairable Stem:** Dual Teflon seals and EPDM O-ring
- Strainer:** 20 mesh stainless steel (optional 50 mesh)
- Options:** Combination P/T Test Valve and Manual Air Vent (CPTA), Drain Valve, or 1/2" Bypass⁴, Extension Option

1/2" – 1-1/2" Housing

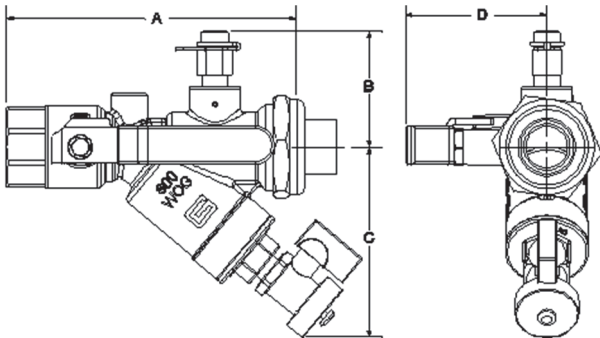

1-1/2"L - 3" Housing

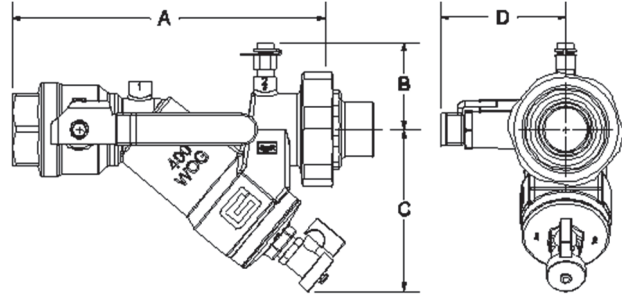

DIMENSIONS & WEIGHTS (NOMINAL)

All dimensions are for planning purposes only and may change without notice.

SIZE	A - FIXED END CONNECTION		UNION END CONNECTION ⁵						B	C	D ⁶	Cv ⁷	WEIGHT (LBS.)	
	FNPT	SWT	FNPT		MNPT		SWT							
1/2"	3.9	3.8												
3/4"	3.9	4.0	1/2":1.0	3/4":N/A ⁸	1/2":1.0	3/4":1.2	3/8",1/2":0.8	3/4":1.1	1.9	2.9	0.5,1.5,2.2	4.7	0.9	
3/4"L	5.4	5.4												
1"	5.4	5.6	1/2",3/4":1.0	1":N/A ⁸	1/2"-3/4":1.0	1":1.4	3/8",3/4":1.0	1/2":0.7	1":1.3	2.2	3.6	2.6, 3.2	9.1	2.3
1-1/4"	7.6	7.7												
1-1/2"	7.5	7.9	1",1-1/4",1-1/2":1.7		1",1-1/4",1-1/2":1.7 ⁹		1",1-1/4":1.7	1-1/2":1.4	2.5	3.1	3.1, 3.7	24.6	5.0	
1-1/2"L, 2"	9.3	9.8	1-1/4", 1-1/2":1.6	2": N/A ⁸	1",1-1/4":1.8	1-1/2", 2":1.6	1-1/4",2":1.6	1-1/2":1.7	2.6	3.7	3.7, 4.3	35	8.8	
2"L	10.9	11.2	2": 2.5		2": 1.6		2": 1.6							
2-1/2"	11.1	N/A	N/A ¹⁰						2.9	4.0	4.0, 4.6	60	12.4	
3"	11.3	N/A	N/A ¹⁰											

For QuickPress connections add 3.1" (1/2") 3.6" (3/4", 3/4"L), 4.1" (1"), to the FNPT length (A) listed for a valve.

NOTES

- ¹ QuickPress is available on 1/2" to 1" valves only. Connections are compatible with popular press tools and are rated for maximum 200 PSI.
- ² Grooved End connection is available on 2-1/2" and 3" valves only.
- ³ Body Tappings for accessories are a leak proof metal to metal seal and do not require pipe dope or tape. Tape or dope should not be used.
- ⁴ Bypass is only available on 1/2" to 1-1/2" valves.
- ⁵ For overall length, add union end connection length to body length.
- ⁶ Space Saver handle standard on 1/2"-3/4" valves. Standard handle on 1" to 3" valves and 1-1/2" extended handle in 1/2" to 3" is compatible with 1-1/2" insulation. Largest extended handle is compatible with 2" insulation.
- ⁷ Cv's are based on a clean 20 mesh stainless steel strainer. When a 50 mesh screen is used, multiply PSID by 1.3.
- ⁸ Tailpiece is not available for this size. Male tailpiece used with coupling.
- ⁹ 1-1/4"-1-1/2" valves can also take 1/2"-3/4" MNPT tailpieces.
- ¹⁰ 2-1/2" and 3" Valves are fixed end by fixed end connection. Union connection is not available.

MODEL NUMBER SELECTION¹¹

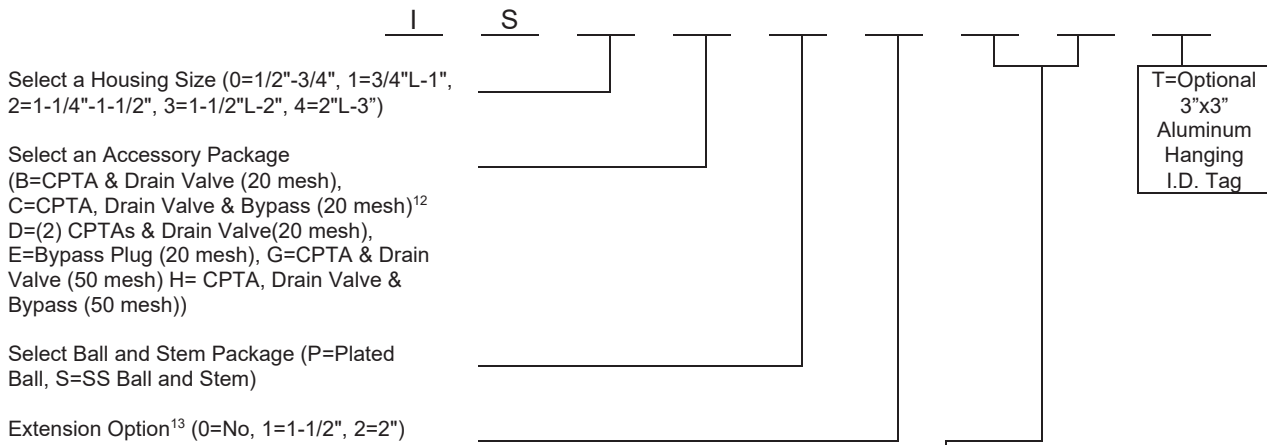

Valve	FIXED END OR UNION END ¹⁴ (No Union Tailpiece=Z)			UNION END ONLY ¹⁴
	Female Threaded	Female Sweat	QuickPress	Male Threaded
IS0	1/2"=E, 3/4"=F ¹⁵	3/8"=K ¹⁶ , 1/2"=L, 3/4"=M	1/2"=2, 3/4"=3	1/2"=H, 3/4"=I
IS1	1/2"=E ¹⁶ , 3/4"=F, 1"=G ¹⁵	3/8"=K ¹⁶ , 1/2"=L ¹⁶ , 3/4"=M, 1"=N	1/2"=2 ¹⁶ , 3/4"=3, 1"=1	1/2"=H, 3/4"=I, 1"=J
IS2	1"=G ¹⁶ , 1-1/4"=P, 1-1/2"=Q	1"=N ¹⁶ , 1-1/4"=K, 1-1/2"=W	N/A	1/2"=H, 3/4"=I, 1"=J, 1-1/4"=S, 1-1/2"=T
IS3	1-1/4"=P ¹⁶ , 1-1/2"=Q, 2"=R ¹⁵	1-1/4"=K ¹⁶ , 1-1/2"=W, 2"=Y	N/A	1-1/4"=S, 1-1/2"=T, 2"=U
IS4 ¹⁴ (Union)	2"=L	2"=Y	N/A	1-1/4"=S, 1-1/2"=T, 2"=U
IS4 ¹⁴ (Fixed End)	2"=L, 2-1/2"=M, 3"=N ¹⁷	N/A	N/A	N/A

NOTES

- ¹¹ Model no. and flow rate are indicated on label affixed to body.
- ¹² C option with bypass is only available for 1/2" to 1-1/2" size.
- ¹³ Extension Option includes handle cover and accessory extensions for either 1-1/2" or 2" insulation.
- ¹⁴ Select the Fixed End First and the Union End Second. For 2-1/2" and 3" size select a 2nd fixed end instead of a union end.
- ¹⁵ Tailpiece is not available for this size. Male tailpiece used with coupling.
- ¹⁶ Fixed end not available for this size. Union tailpiece only.
- ¹⁷ For Grooved End option use MG=2-1/2" and NG=3".



SPECIFICATIONS

PSI/Temperature Rating: 175 PSI / 200° F
Body Material: Cast Iron ASTM A126 Class B
End Connections: Flanges ANSI B16.1 Class 125
Body Tappings: Port 1: 1/4" NPT with PT; Port 2: 1/4" NPT; Port 3: 3/4" NPT; Port 4: Ball Valve to be used as drain valve
Strainer: Stainless steel 304 ASTM 167
Butterfly Valve: Cast Iron ASTM A126 Class B
 EPDM, Aluminum bronze, stainless steel stem
Assembly: Valve comes fully assembled. Mating flanges supplied by others.

DIMENSIONS & WEIGHTS (NOMINAL)

All dimensions are for planning purposes only and may change without notice.

SIZE	A LENGTH	B ³	C	D	HOLE Dia.	# OF HOLES	DRAIN SIZE	WEIGHT (LBS.)
2-1/2"	12.8	1.8	10.5	6.0	0.75	4	1"	57
3"	16.4	1.8	10.5	6.3	0.75	4	1"	86
4"	15.9	2.0	10.5	7.0	0.88	8	1-1/4"	90
5"	18.1	2.1	10.5	7.5	0.88	8	1-1/4"	150
6"	21.1	2.1	10.5	8.0	0.88	8	1-1/2"	196
8"	26.1	2.5	14.0	9.5	0.88	8	1-1/2"	245

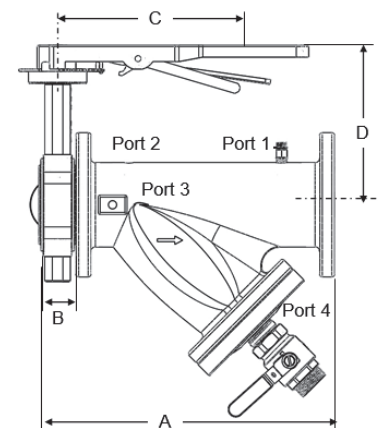

MODEL NUMBER SELECTION

3 6 5 0 B

Insert M=2-1/2", N=3", P=4", Q=5", R=6" S=8"

Add "W" for optional weldneck flanges

OPTIONS (ORDER AS SEPARATE LINE ITEMS, INSTALLED IN THE FIELD):

Pressure/Temperature Test Valve – 1/4": 6889
 Manual Air Vent – 1/4": 738-01

NOTES

³ B dimension does not include seat.

SPECIFICATIONS

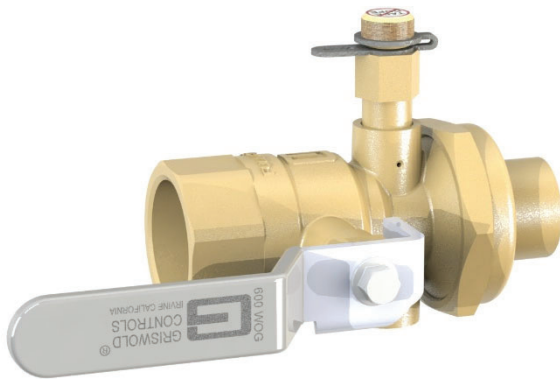

PSI/Temperature Rating: 600 WOG 400 PSI / 250°F
Body Material: Forged Brass ASTM B283-06
End Connections: Brass – NPT, Sweat or QuickPress¹
Ball Valve Seals: Teflon
Union Seal: EPDM O-ring
Body Tappings²: (2) Bosses for CPTAs and Drain Valve
Ball Valve: Nickel-plated brass ball, full port
 Optional: Stainless steel ball
Field Repairable Stem: Dual Teflon seals and EPDM O-ring
Assembly: Valve comes fully assembled.
Options: Combination P/T Test Valve and Manual Air Vent (CPTA), Drain Valve, Extension Option

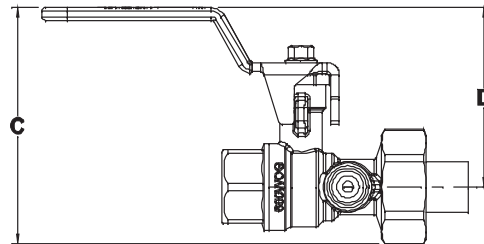
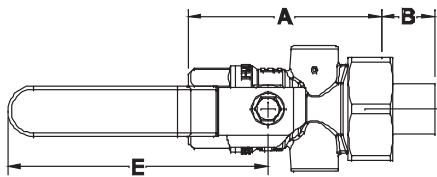

DIMENSIONS & WEIGHTS (NOMINAL)

All dimensions are for planning purposes only and may change without notice.

SIZE	A - FIXED END CONNECTION		B - UNION END CONNECTION ³						C	D ⁴	E	Cv ⁵	WEIGHT (LBS.)		
	FNPT	SWT	FNPT		MNPT		SWT								
1/2"	2.6	2.5	1/2":1.0	3/4":N/A ⁶	1/2":1.0	3/4":1.2	3/8",1/2":0.8		3/4":1.1	3.0	1.5	3.7	11	0.7	
3/4"	2.6	3.2					3/8",1/2":0.8								
3/4"L	3.0	3.1	1/2",3/4":1.0	1":N/A ⁶	1/2"-3/4":1.0	1":1.4	3/8",3/4":1.0		1":1.3	4.0	2.9	5.0	51	1.5	
1"	3.2	3.4					1/2":0.7								
1-1/4"	3.9	4.1	1",1-1/4",1-1/2":1.7		1",1-1/4",1-1/2":1.7 ⁷		1",1-1/4":1.7		1-1/2":1.4		4.3	3.1	5.0	99	3.5
1-1/2"	4.4	4.6													
2"	5.1	5.5	1-1/4",1-1/2":1.6	2": N/A ⁶	1",1-1/4":1.8	1-1/2", 2":1.6	1-1/4",2":1.6		1-1/2":1.7	5.3	4.0	5.5	260	6.9	

For QuickPress connections add 3.1" (1/2"), 3.6" (3/4", 3/4"L), 4.1" (1") to the FNPT length (A) listed for a valve.

NOTES

- ¹ QuickPress is available on 1/2" to 1" valves only. Connections are compatible with popular press tools and are rated for maximum 200 PSI.
- ² Body Tappings for accessories are a leak proof metal to metal seal and do not require pipe dope or tape. Tape or dope should not be used.
- ³ For overall length, add union end connection length to body length.
- ⁴ Space Saver handle standard on 1/2"-3/4" valves. Standard handle on 1" to 3" valves and 1-1/2" extended handle in 1/2" to 3" is compatible with 1-1/2" insulation. Largest extended handle is compatible with 2" insulation.
- ⁵ Cv's are used to calculate the pressure drop. $PSID=(Flow/Cv)^2$.
- ⁶ Tailpiece is not available for this size. Male tailpiece used with coupling.
- ⁷ 1-1/4"-1-1/2" valves can also take 1/2"-3/4" MNPT tailpieces.

MODEL NUMBER SELECTION

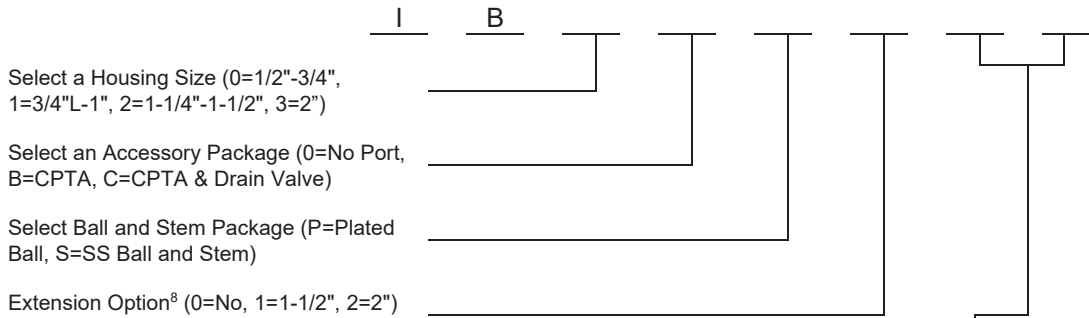

Valve	FIXED END OR UNION END ⁹ (No Union Tailpiece=Z)			UNION END ONLY ⁹
	Female Threaded	Female Sweat	QuickPress	Male Threaded
IB0	1/2"=E, 3/4"=F ⁶	3/8"=K ¹⁰ , 1/2"=L, 3/4"=M	1/2"=2, 3/4"=3	1/2"=H, 3/4"=I
IB1	1/2"=E ¹⁰ , 3/4"=F, 1"=G ⁶	3/8"=K ¹⁰ , 1/2"=L ¹⁰ , 3/4"=M, 1"=N	1/2"=2 ¹⁰ , 3/4"=3, 1"=1	1/2"=H, 3/4"=I, 1"=J
IB2	1"=G ¹⁰ , 1-1/4"=P, 1-1/2"=Q	1"=N ¹⁰ , 1-1/4"=K, 1-1/2"=W	N/A	1/2"=H, 3/4"=I, 1"=J, 1-1/4"=S, 1-1/2"=T
IB3	1-1/4"=P ¹⁰ , 1-1/2"=Q ¹⁰ , 2"=R ⁶	1-1/4"=K ¹⁰ , 1-1/2"=W ¹⁰ , 2"=Y	N/A	1-1/4"=S, 1-1/2"=T, 2"=U

NOTES

⁸ Extension Option includes handle cover and accessory extensions for either 1-1/2" or 2" insulation.

⁹ Select the Fixed End First and the Union End Second.

¹⁰ Fixed End not available for this size. Union tailpiece only.

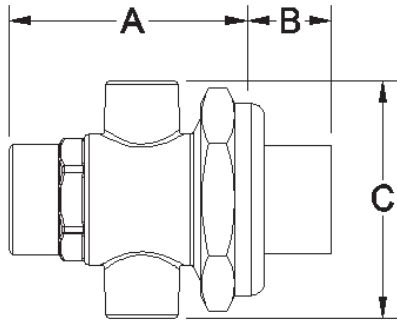

SPECIFICATIONS:

PSI / Temperature Rating: 400 PSI/250°F
Body Material: Forged Brass ASTM B283-06
End Connections: Brass – NPT, Sweat or ProPress¹
Union Seal: EPDM O-ring
Body Tappings²: Two 1/4" bosses
Options: Combination P/T Test Valve and Manual Air Vent (CPTA), Drain Valve, Insulation Option

DIMENSIONS & WEIGHTS (NOMINAL) (inches and lbs. unless otherwise noted)

SIZE	A - FIXED END CONNECTION		B - UNION END CONNECTION ³						C	WEIGHT (LBS.)	
	FNPT	SWT	FNPT		MNPT		SWT				
3/8"	N/A	1.7									
1/2"	2.0	1.9	1/2":1.0	3/4":N/A ⁴	1/2":1.0	3/4":1.2	3/8",1/2":0.8	3/4":1.1	1.2	0.3	
3/4"	1.9	1.9									
1"	2.2	2.2	1/2",3/4":1.0	1":N/A ⁴	1/2"-3/4":1.0	1":1.4	3/8",3/4":1.0	1/2":0.7	1":1.3	2.0	1.1
1-1/4"	2.6	2.6	1",1-1/4",1-1/2":1.7		1",1-1/4",1-1/2":1.7 ⁵		1",1-1/4":1.7		1-1/2":1.4	2.7	2.4
1-1/2"	2.8	2.8									
2"	2.8	2.8	1-1/4",1-1/2":1.6	2":N/A ⁴	1",1-1/4":1.8	1-1/2",2":1.6	1-1/4",2":1.6	1-1/2":1.7		3.4	3.2
2-1/2"	3.0	N/A	1-1/2":=	3":2.2	1-1/2"-2-1/2":1.5	3":2.5	2":2.0		3.7	5.1	
3"	3.2	N/A	2-1/2":1.2								5.6

For ProPress connections add 3.1" (1/2"), 3.6" (3/4"), 4.1" (1") to the FNPT length (A) listed for a valve. These are for planning purpose only, contact factory for actual measurement at time of order.

NOTES

- ¹ ProPress is available on 1/2" to 1" valves only.
- ² Body Tappings for accessories are a leak proof metal to metal seal and do not require pipe dope or tape. Tape or dope should not be used.
- ³ For overall length, add union end connection length to body length.
- ⁴ Tailpiece is not available for this size. Male tailpiece used with coupling.
- ⁵ 1-1/4"-1-1/2" valves can also take 1/2"-3/4" MNPT tailpieces.

Replaces form F-3033L

This specification © 2011 Griswold Controls

MODEL NUMBER SELECTION

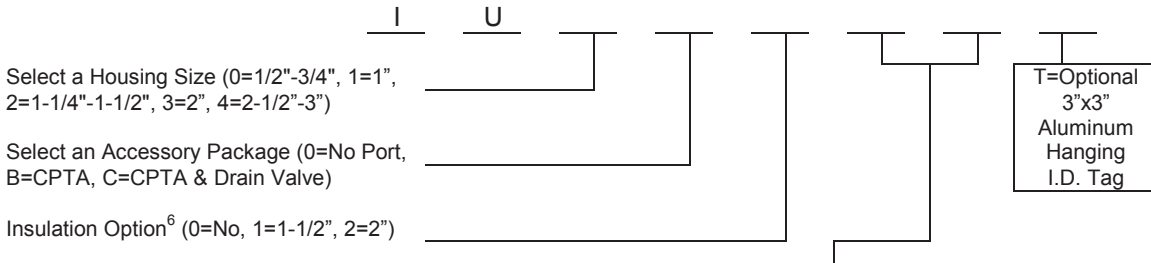

Valve	FIXED END OR UNION END ⁷ (No Union Tailpiece=Z)			UNION END ONLY ⁷
	Female Threaded	Female Sweat	ProPress ⁸	Male Threaded
IU0	1/2"=E, 3/4"=F ⁴	3/8"=K, 1/2"=L, 3/4"=M	1/2"=2, 3/4"=3	1/2"=H, 3/4"=I
IU1	1/2"=E ⁹ , 3/4"=F ⁹ , 1"=G ⁴	3/8"=K ⁹ , 1/2"=L ⁹ , 3/4"=M ⁹ , 1"=N	1/2"=2 ⁹ , 3/4"=3 ⁹ , 1"=1	1/2"=H, 3/4"=I, 1"=J
IU2	1"=G ⁹ , 1-1/4"=P, 1-1/2"=Q	1"=N ⁹ , 1-1/4"=K, 1-1/2"=W	N/A	1/2"=H, 3/4"=I, 1"=J, 1-1/4"=S, 1-1/2"=T
IU3	1-1/4"=P ⁹ , 1-1/2"=Q ⁹ , 2"=R ⁴	1-1/4"=K ⁹ , 1-1/2"=W ⁹ , 2"=Y	N/A	1-1/4"=S, 1-1/2"=T, 2"=U
IU4	1-1/2"=Q ⁹ , 2"=R ⁹ , 2-1/2"=A, 3"=B	2"=Y ⁹	N/A	1-1/2"=T, 2"=U, 2-1/2"=C, 3"=D

NOTES

- ⁶ Insulation Option includes Accessory extensions.
 - ⁷ Select the Fixed End First and the Union End Second.
 - ⁸ ProPress option is a tailpiece on the union side and/or a FNPT valve with a ProPress adapter on the fixed end side.
 - ⁹ Fixed end not available for this size. Union tailpiece only.
- Replaces form F-3033L

This specification © 2011 Griswold Controls

2803 Barranca Parkway, Irvine, CA 92606
 (949) 559-6000 Fax (949) 559-6088
 www.GriswoldControls.com



DRAIN VALVE "DV"

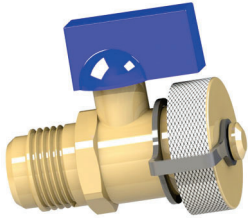

SPECIFICATIONS

- PSI / Temperature Rating:** 400 WOG (300 PSI, 250°F)
- Body and Cap Material:** Brass
- Ball Valve:** Nickel-plated brass ball
- End Connection:** Straight UNF¹
- Cap Connection:** 3/4" NPSH
- Handle Rotation:** Straight is open. Rotate clockwise to close 1/4 turn.
- Part Number:** 1/2" 9133-07, 3/4" 7342-25

COMBINATION PRESSURE/TEMPERATURE TEST VALVE AND AIRVENT CPTA² and PT Test Port Valves



SPECIFICATIONS

- PSI / Temperature Rating:** 1000 PSI / 350°F
- Body:** Brass
- Cap:** Brass with plastic retainer
- Seal:** Nordel
- End Connection:** CPTA: 1/2" Straight UNF¹, PT: 1/4" NPT
- Part Number:** CPTA Standard: 6889-07; CPTA 2-1/2" extended version: 6889-17
PT Standard: 6889; PT 3" extended version: 6889-03

NOTES

¹ Body Tappings for DV, CPTA, and MAV are a leak proof metal seal and do not require pipe dope or tape. Tape or dope should not be used.
² To vent air the CPTA must be used in the Griswold Controls valve body tapping with an integral hole. Back the CPTA out one half a turn to vent the air through the hole.

IMPORTANT NOTE REGARDING ACCESSORIES!

***Please take the time to read this instruction sheet.
Disregarding these guidelines may adversely affect your piping accessories.***

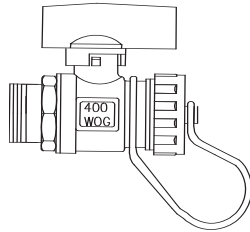

Drain Valve

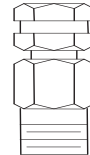

CPTA

Griswold Controls' valves may contain drain valves and/or combination P/T test valve and manual air vent (CPTA). Both types of accessory components have a straight thread and do not require any pipe dope or tape sealant. Using pipe dope or sealant may cause problems with the seal and may clog the hole in the housing that is used to vent air with the CPTA. Extensions for these components also have a straight thread.

To eliminate the air from the system the Griswold Controls combination P/T test valve and manual air vent (CPTA) can be used. To remove the air back out the CPTA half a turn from the housing to vent air using a small wrench. When you begin to see water come out the air hole in the housing, tighten the CPTA. If an extension is used the hole is in the extension piece and the CPTA can be backed out of the extension a half a turn to eliminate the air. A second wrench will be required to hold the extension in place while the CPTA is being rotated.

QuickSet

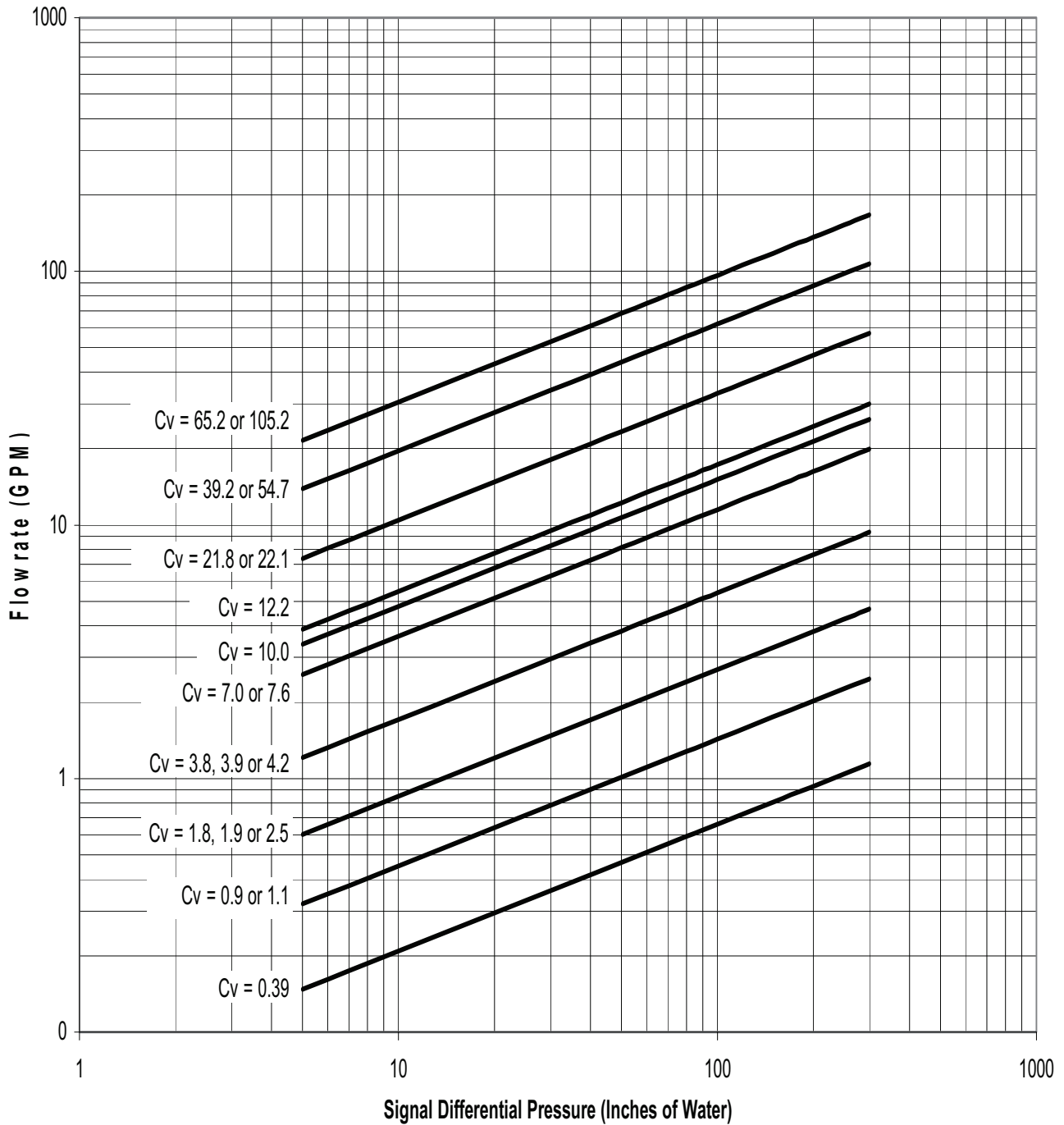

Replaces form F-4040E

This specification © 2008 Griswold Controls

2803 Barranca Parkway, Irvine, CA 92606
(949) 559-6000 Fax (949) 559-6088
www.GriswoldControls.com

4/08
F-4040F



This chart performs two functions:

- It allows you to calculate the permanent pressure drop for any size Quickset or Metering Station. This figure is useful mostly in the design process, for system calculations.
- It allows you to find the signal in inches at any given GPM within the recommended flow range. The chart gives pressure drops for Metering Station, Quickset, Extended Metering Station and Extended Quickset. Signal is given for each piping configuration: Straight Pipe Length is an installation where there is adequate straight-run piping before and after the valve. Piped at Elbow is for valves installed immediately after an elbow bend in piping. Piped at Control Valve is for valves installed immediately after a control valve.

The Pressure Drop values shown reflect the idea that it is desirable to have permanent pressure drop of less than 1 lb, requiring less pump.

Example of chart usage:

Obtain the Permanent Pressure Drop and Signal for a 3" Quickset at 68 GPM piped next to an elbow.

Flowrate GPM	2-1/2"									3"						4"						
	Permanent Pressure Drop			Signal			Permanent Pressure Drop			Signal			Permanent Pressure Drop			Signal						
	Metering Station Cv	QuickSet Cv	Metering Station Extended Cv	QuickSet Extended Cv	Straight Pipe Length Fc	Piped at Elbow Fc	Piped at Control Valve Fc	Metering Station Cv	QuickSet Cv	Metering Station Extended Cv	QuickSet Extended Cv	Straight Pipe Length Fc	Piped at Elbow Fc	Piped at Control Valve Fc	Metering Station Cv	QuickSet Cv	Metering Station Extended Cv	QuickSet Extended Cv	Straight Pipe Length Fc	Piped at Elbow Fc	Piped at Control Valve Fc	
32.0	0.04	0.06	0.04	0.06	13.5	13.5	13.5															
34.0	0.04	0.06	0.04	0.06	15.3	15.3	15.3															
36.0	0.04	0.07	0.05	0.07	17.1	17.1	17.1															
38.0	0.05	0.08	0.05	0.08	19.1	19.1	19.1															
40.0	0.05	0.09	0.06	0.09	21.1	21.1	21.1															
42.0	0.06	0.10	0.06	0.10	23.3	23.3	23.3															
44.0	0.07	0.11	0.07	0.11	25.6	25.6	25.6															
46.0	0.07	0.12	0.07	0.12	28.0	28.0	28.0															
48.0	0.08	0.13	0.08	0.13	30.4	30.4	30.4															
50.0	0.09	0.14	0.09	0.14	33.0	33.0	33.0															
52.0	0.09	0.15	0.09	0.15	35.7	35.7	35.7	0.07	0.07	0.07	0.07	12.5	12.5	11.1								
54.0	0.10	0.16	0.10	0.16	38.5	38.5	38.5	0.04	0.07	0.05	0.08	13.5	13.5	12.0								
56.0	0.11	0.17	0.11	0.17	41.4	41.4	41.4	0.04	0.08	0.05	0.09	14.5	14.5	12.9								
58.0	0.12	0.18	0.12	0.19	44.4	44.4	44.4	0.05	0.08	0.06	0.09	15.6	15.6	13.8								
60.0	0.12	0.20	0.13	0.20	47.6	47.6	47.6	0.05	0.09	0.06	0.10	16.7	16.7	14.8								
62.0	0.13	0.21	0.13	0.21	50.8	50.8	50.8	0.05	0.10	0.07	0.11	17.8	17.8	15.8								
64.0	0.14	0.22	0.14	0.23	54.1	54.1	54.1	0.06	0.10	0.07	0.11	19.0	19.0	16.8								
66.0	0.15	0.24	0.15	0.24	57.6	57.6	57.6	0.06	0.11	0.07	0.12	20.2	20.2	17.9								
68.0	0.16	0.25	0.16	0.26	61.1	61.1	61.1	0.06	0.11	0.08	0.13	21.4	21.4	19.0								
70.0	0.17	0.27	0.17	0.27	64.7	64.7	64.7	0.07	0.12	0.08	0.14	22.7	22.7	20.1								
72.0	0.18	0.28	0.18	0.29	68.5	68.5	68.5	0.07	0.13	0.09	0.15	24.0	24.0	21.3								
74.0	0.19	0.30	0.19	0.30	72.3	72.3	72.3	0.08	0.14	0.09	0.15	25.3	25.3	22.5								
76.0	0.20	0.32	0.20	0.32	76.3	76.3	76.3	0.08	0.14	0.10	0.16	26.7	26.7	23.7								
78.0	0.21	0.33	0.21	0.34	80.4	80.4	80.4	0.08	0.15	0.10	0.17	28.2	28.2	25.0								
80.0	0.22	0.35	0.22	0.36	84.6	84.6	84.6	0.09	0.16	0.11	0.18	29.6	29.6	26.3								
85	0.25	0.40	0.25	0.40	95.5	95.5	95.5	0.10	0.18	0.12	0.20	33.4	33.4	29.7								
90	0.28	0.44	0.28	0.45	107.0	107.0	107.0	0.11	0.20	0.14	0.23	37.5	37.5	33.3								
95	0.31	0.50	0.32	0.50	119.2	119.2	119.2	0.12	0.22	0.15	0.25	41.8	41.8	37.1								
100	0.34	0.55	0.35	0.56	132.1	132.1	132.1	0.14	0.25	0.17	0.28	46.3	46.3	41.1								
105	0.38	0.60	0.39	0.61	145.7	145.7	145.7	0.15	0.27	0.19	0.31	51.0	51.0	45.3								

Flowrate	3"						
	Permanent Pressure Drop				Signal		
	Metering Station	QuickSet	Metering Station Extended	QuickSet Extended	Straight Pipe Length	Piped at Elbow	Piped at Control Valve
GPM	Cv	Cv	Cv	Cv	Fc	Fc	Fc
	269	201	242	189	14.7	14.7	15.6
	PSID	PSID	PSID	PSID	INWC	INWC	INWC
32.0	0.01	0.03	0.02	0.03	4.7	4.7	4.2
34.0	0.02	0.03	0.02	0.03	5.3	5.3	4.8
36.0	0.02	0.03	0.02	0.04	6.0	6.0	5.3
38.0	0.02	0.04	0.02	0.04	6.7	6.7	5.9
40.0	0.02	0.04	0.03	0.04	7.4	7.4	6.6
42.0	0.02	0.04	0.03	0.05	8.2	8.2	7.2
44.0	0.03	0.05	0.03	0.05	9.0	9.0	8.0
46.0	0.03	0.05	0.04	0.06	9.8	9.8	8.7
48.0	0.03	0.06	0.04	0.06	10.7	10.7	9.5
50.0	0.03	0.06	0.04	0.07	11.6	11.6	10.3
52.0	0.04	0.07	0.05	0.08	12.5	12.5	11.1
54.0	0.04	0.07	0.05	0.08	13.5	13.5	12.0
56.0	0.04	0.08	0.05	0.09	14.5	14.5	12.9
58.0	0.05	0.08	0.06	0.09	15.6	15.6	13.8
60.0	0.05	0.09	0.06	0.10	16.7	16.7	14.8
62.0	0.05	0.10	0.07	0.11	17.8	17.8	15.8
64.0	0.06	0.10	0.07	0.11	19.0	19.0	16.8
66.0	0.06	0.11	0.07	0.12	20.2	20.2	17.9
68.0	0.06	0.11	0.08	0.13	21.4	21.4	19.0
70.0	0.07	0.12	0.08	0.14	22.7	22.7	20.1
72.0	0.07	0.13	0.09	0.15	24.0	24.0	21.3
74.0	0.08	0.14	0.09	0.15	25.3	25.3	22.5
76.0	0.08	0.14	0.10	0.16	26.7	26.7	23.7
78.0	0.08	0.15	0.10	0.17	28.2	28.2	25.0
80.0	0.09	0.16	0.11	0.18	29.6	29.6	26.3
85	0.10	0.18	0.12	0.20	33.4	33.4	29.7
90	0.11	0.20	0.14	0.23	37.5	37.5	33.3
95	0.12	0.22	0.15	0.25	41.8	41.8	37.1
100	0.14	0.25	0.17	0.28	46.3	46.3	41.1
105	0.15	0.27	0.19	0.31	51.0	51.0	45.3
110	0.17	0.30	0.21	0.34	56.0	56.0	49.7
115	0.18	0.33	0.23	0.37	61.2	61.2	54.3
120	0.20	0.36	0.25	0.40	66.6	66.6	59.2
125	0.22	0.39	0.27	0.44	72.3	72.3	64.2
130	0.23	0.42	0.29	0.47	78.2	78.2	69.4
135	0.25	0.45	0.31	0.51	84.3	84.3	74.9
140	0.27	0.49	0.33	0.55	90.7	90.7	80.5
145	0.29	0.52	0.36	0.59	97.3	97.3	86.4
150	0.31	0.56	0.38	0.63	104.1	104.1	92.5
155	0.33	0.59	0.41	0.67	111.2	111.2	98.7
160	0.35	0.63	0.44	0.72	118.5	118.5	105.2
165	0.38	0.67	0.46	0.76	126.0	126.0	111.9
170	0.40	0.72	0.49	0.81	133.7	133.7	118.8
175	0.42	0.76	0.52	0.86	141.7	141.7	125.8
180	0.45	0.80	0.55	0.91	149.9	149.9	133.1
185	0.47	0.85	0.58	0.96	158.4	158.4	140.6
190	0.50	0.89	0.62	1.01	167.1	167.1	148.3
200	0.55	0.99	0.68	1.12	185.1	185.1	164.4
210	0.61	1.09	0.75	1.23	204.1	204.1	181.2
220	0.67	1.20	0.83	1.35	224.0	224.0	198.9
230	0.73	1.31	0.90	1.48	244.8	244.8	217.4
240	0.80	1.43	0.98	1.61	266.6	266.6	236.7
250	0.86	1.55	1.07	1.75	289.2	289.2	256.8

Replaces form F-4439

This specification © 2012 Griswold Controls

1/12
F-4439E

2803 Barranca Parkway, Irvine, CA 92606
(949) 559-6000 Fax (949) 559-6088
www.GriswoldControls.com



Flowrate	4"						
	Permanent Pressure Drop				Signal		
	Metering Station	QuickSet	Metering Station Extended	QuickSet Extended	Straight Pipe Length	Piped at Elbow	Piped at Control Valve
GPM	Cv	Cv	Cv	Cv	Fc	Fc	Fc
	PSID	PSID	PSID	PSID	INWC	INWC	INWC
58.0	0.01	0.02	0.01	0.02	5.0	5.0	4.5
60.0	0.01	0.02	0.01	0.02	5.3	5.3	4.8
62.0	0.01	0.02	0.02	0.03	5.7	5.7	5.2
64.0	0.01	0.02	0.02	0.03	6.1	6.1	5.5
66.0	0.01	0.03	0.02	0.03	6.4	6.4	5.8
68.0	0.01	0.03	0.02	0.03	6.8	6.8	6.2
70.0	0.01	0.03	0.02	0.03	7.2	7.2	6.6
72.0	0.02	0.03	0.02	0.03	7.7	7.7	7.0
74.0	0.02	0.03	0.02	0.04	8.1	8.1	7.3
76.0	0.02	0.03	0.02	0.04	8.5	8.5	7.8
78.0	0.02	0.03	0.02	0.04	9.0	9.0	8.2
80.0	0.02	0.04	0.02	0.04	9.5	9.5	8.6
85	0.02	0.04	0.03	0.05	10.7	10.7	9.7
90	0.02	0.05	0.03	0.05	12.0	12.0	10.9
95	0.03	0.05	0.04	0.06	13.4	13.4	12.1
100	0.03	0.06	0.04	0.07	14.8	14.8	13.4
105	0.03	0.06	0.04	0.07	16.3	16.3	14.8
110	0.04	0.07	0.05	0.08	17.9	17.9	16.2
115	0.04	0.08	0.05	0.09	19.6	19.6	17.7
120	0.04	0.08	0.06	0.10	21.3	21.3	19.3
125	0.05	0.09	0.06	0.10	23.1	23.1	21.0
130	0.05	0.10	0.07	0.11	25.0	25.0	22.7
135	0.05	0.10	0.07	0.12	27.0	27.0	24.5
140	0.06	0.11	0.08	0.13	29.0	29.0	26.3
145	0.06	0.12	0.08	0.14	31.1	31.1	28.2
150	0.07	0.13	0.09	0.15	33.3	33.3	30.2
155	0.07	0.14	0.09	0.16	35.5	35.5	32.2
160	0.08	0.15	0.10	0.17	37.9	37.9	34.3
165	0.08	0.16	0.11	0.18	40.3	40.3	36.5
170	0.09	0.17	0.11	0.19	42.8	42.8	38.8
175	0.09	0.18	0.12	0.20	45.3	45.3	41.1
180	0.10	0.19	0.13	0.22	47.9	47.9	43.5
185	0.10	0.20	0.13	0.23	50.6	50.6	45.9
190	0.11	0.21	0.14	0.24	53.4	53.4	48.4
200	0.12	0.23	0.16	0.27	59.2	59.2	53.7
210	0.13	0.25	0.17	0.29	65.2	65.2	59.2
220	0.14	0.28	0.19	0.32	71.6	71.6	64.9
230	0.16	0.30	0.21	0.35	78.3	78.3	71.0
240	0.17	0.33	0.22	0.38	85.2	85.2	77.3
250	0.19	0.36	0.24	0.42	92.5	92.5	83.9
260	0.20	0.39	0.26	0.45	100.0	100.0	90.7
270	0.22	0.42	0.28	0.49	107.8	107.8	97.8
280	0.23	0.45	0.31	0.52	116.0	116.0	105.2
290	0.25	0.48	0.33	0.56	124.4	124.4	112.8
300	0.27	0.52	0.35	0.60	133.1	133.1	120.8
325	0.31	0.61	0.41	0.71	156.3	156.3	141.7
350	0.36	0.70	0.48	0.82	181.2	181.2	164.4
375	0.42	0.81	0.55	0.94	208.0	208.0	188.7
400	0.48	0.92	0.62	1.07	236.7	236.7	214.7
425	0.54	1.04	0.71	1.21	267.2	267.2	242.4
450	0.60	1.16	0.79	1.35	299.6	299.6	271.7
460	0.63	1.22	0.83	1.41	313.0	313.0	283.9

Replaces form F-4439

This specification © 2012 Griswold Controls

1/12
F-4439E

2803 Barranca Parkway, Irvine, CA 92606
(949) 559-6000 Fax (949) 559-6088
www.GriswoldControls.com



6"							
Flowrate	Permanent Pressure Drop				Signal		
	Metering Station	QuickSet	Metering Station Extended	QuickSet Extended	Straight Pipe Length	Piped at Elbow	Piped at Control Valve
	Cv	Cv	Cv	Cv	Fc	Fc	Fc
GPM	1250	980	900	782	62	64	66
	PSID	PSID	PSID	PSID	INWC	INWC	INWC
140	0.01	0.02	0.02	0.03	5.1	4.8	4.5
145	0.01	0.02	0.03	0.03	5.5	5.1	4.8
150	0.01	0.02	0.03	0.04	5.9	5.5	5.2
155	0.02	0.03	0.03	0.04	6.3	5.9	5.5
160	0.02	0.03	0.03	0.04	6.7	6.3	5.9
165	0.02	0.03	0.03	0.04	7.1	6.6	6.3
170	0.02	0.03	0.04	0.05	7.5	7.1	6.6
175	0.02	0.03	0.04	0.05	8.0	7.5	7.0
180	0.02	0.03	0.04	0.05	8.4	7.9	7.4
185	0.02	0.04	0.04	0.06	8.9	8.4	7.9
190	0.02	0.04	0.04	0.06	9.4	8.8	8.3
200	0.03	0.04	0.05	0.07	10.4	9.8	9.2
210	0.03	0.05	0.05	0.07	11.5	10.8	10.1
220	0.03	0.05	0.06	0.08	12.6	11.8	11.1
230	0.03	0.06	0.07	0.09	13.8	12.9	12.1
240	0.04	0.06	0.07	0.09	15.0	14.1	13.2
250	0.04	0.07	0.08	0.10	16.3	15.3	14.3
260	0.04	0.07	0.08	0.11	17.6	16.5	15.5
270	0.05	0.08	0.09	0.12	19.0	17.8	16.7
280	0.05	0.08	0.10	0.13	20.4	19.1	18.0
290	0.05	0.09	0.10	0.14	21.9	20.5	19.3
300	0.06	0.09	0.11	0.15	23.4	22.0	20.7
325	0.07	0.11	0.13	0.17	27.5	25.8	24.2
350	0.08	0.13	0.15	0.20	31.9	29.9	28.1
375	0.09	0.15	0.17	0.23	36.6	34.3	32.3
400	0.10	0.17	0.20	0.26	41.6	39.1	36.7
425	0.12	0.19	0.22	0.30	47.0	44.1	41.5
450	0.13	0.21	0.25	0.33	52.7	49.4	46.5
460	0.14	0.22	0.26	0.35	55.0	51.7	48.6
475	0.14	0.23	0.28	0.37	58.7	55.1	51.8
500	0.16	0.26	0.31	0.41	65.0	61.0	57.4
525	0.18	0.29	0.34	0.45	71.7	67.3	63.3
550	0.19	0.31	0.37	0.49	78.7	73.9	69.4
575	0.21	0.34	0.41	0.54	86.0	80.7	75.9
600	0.23	0.37	0.44	0.59	93.7	87.9	82.6
625	0.25	0.41	0.48	0.64	101.6	95.4	89.7
650	0.27	0.44	0.52	0.69	109.9	103.1	97.0
675	0.29	0.47	0.56	0.75	118.5	111.2	104.6
700	0.31	0.51	0.60	0.80	127.5	119.6	112.5
725	0.34	0.55	0.65	0.86	136.7	128.3	120.7
750	0.36	0.59	0.69	0.92	146.3	137.3	129.1
775	0.38	0.63	0.74	0.98	156.3	146.6	137.9
800	0.41	0.67	0.79	1.05	166.5	156.3	146.9
825	0.44	0.71	0.84	1.11	177.1	166.2	156.3
850	0.46	0.75	0.89	1.18	188.0	176.4	165.9
875	0.49	0.80	0.95	1.25	199.2	186.9	175.8
900	0.52	0.84	1.00	1.32	210.7	197.8	186.0
920	0.54	0.88	1.04	1.38	220.2	206.6	194.3
950	0.58	0.94	1.11	1.48	234.8	220.3	207.2
1000	0.64	1.04	1.23	1.64	260.1	244.1	229.6
1050	0.71	1.15	1.36	1.80	286.8	269.2	253.1
1100	0.77	1.26	1.49	1.98	314.8	295.4	277.8

Replaces form F-4439

This specification © 2012 Griswold Controls

1/12
F-4439E

2803 Barranca Parkway, Irvine, CA 92606
(949) 559-6000 Fax (949) 559-6088
www.GriswoldControls.com

