

Submittal #233423-2.0 - Product Data – Kitchen Hood Exhausters 233423 - HVAC POWER VENTILATORS

Revision	0	Submittal Manager	Matthew Crawford (Megen Construction Company)
Status	Open	Date Created	Sep 5, 2025
Issue Date	Sep 5, 2025	Spec Section	233423 - HVAC POWER VENTILATORS
Responsible Contractor	Feldkamp Enterprises, Inc	Received From	Heather Wyatt (Feldkamp Enterprises, Inc)
Received Date		Submit By	
Final Due Date	Sep 26, 2025	Lead Time	
		Cost Code	
Location		Type	Product Data
Submittal Package			
Approvers	Tanya Tedesco (Motz Engineering), Brian Trettenero (Motz Engineering), Jessica Scholl (MSA Architects), Brad Sir Louis (MSA Architects)		
Ball in Court	Tanya Tedesco (Motz Engineering), Brian Trettenero (Motz Engineering)		
Distribution	Brad Sir Louis (MSA Architects), Christopher Todd (Megen Construction Company), Jeff Williams (Megen Construction Company), Jessica Scholl (MSA Architects), Stacy Beck (Megen Construction Company)		
Description	Please see the attached submittal for kitchen exhausters that includes product data, dimensional drawings, and manufacturer information for your review and approval.		

Submittal Workflow

Name	Sent Date	Due Date	Returned Date	Response	Attachments
General Information Attachments					233423.2.10 - HVAC Power Ventilators [Kitchen Hood Exhausters].pdf
Tanya Tedesco	Sep 5, 2025	Sep 19, 2025		Pending	
Brian Trettenero	Sep 5, 2025	Sep 19, 2025		Pending	
Jessica Scholl		Sep 26, 2025		Pending	
Brad Sir Louis		Sep 26, 2025		Pending	

SHOP DRAWINGS

X Reviewed Furnish as Corrected

Rejected Revise and Resubmit

This review is only for general conformance with the design concept of the project and general compliance with the information given in the Contract Documents. Corrections or comments made on the shop drawings during this review do not relieve contractor from compliance with the requirements of the plans and specifications. Approval of a specific item shall not include approval of an assembly of which the item is a component. Contractor is responsible for: dimensions to be confirmed and correlated at the job site; information that pertains solely to the fabrication process or to the means, methods, techniques, sequences and procedures of construction; coordination of the work of all trades; and for performing all work in a safe and satisfactory manner.

Note: Errors in shop drawings or undue delays in making corrections are not an acceptable excuse for changing delivery dates from imperfect fabrication.

MOTZ CONSULTING ENGINEERS, INC.
 By: Jeff Haynay Date: 09/12/2025



Feldkamp Enterprises
 3642 Muddy Creek Rd
 Cincinnati, Ohio 45238
 P: (513) 347-4500

Project: 1351 Princeton Athletic Facility
 1100 Viking Way
 Cincinnati, Ohio 45246

Submittal #23 34 23-2.0 - Kitchen Hood Exhausters 23 34 23 - HVAC Power Ventilators

Revision	0	Submittal Manager	Heather Wyatt (Marsden Mechanical L.L.C. d/b/a/ Feldkamp Enterprises)
Status	Open	Date Created	Aug 1, 2025
Issue Date	Aug 1, 2025	Spec Section	23 34 23 - HVAC Power Ventilators
Responsible Contractor	Controlled Air, Inc.	Received From	Patrick Tepe (Controlled Air, Inc.)
Received Date		Submit By	
Final Due Date	Aug 18, 2025	Lead Time	
		Cost Code	
Location		Type	Product Information
Submittal Package			
Manufacturer	Greasemaster		
Approvers	Heather Wyatt (Marsden Mechanical L.L.C. d/b/a/ Feldkamp Enterprises), Matt Crawford (Megen Construction)		
Ball in Court	Heather Wyatt (Marsden Mechanical L.L.C. d/b/a/ Feldkamp Enterprises)		
Distribution	Brian Linblad (Marsden Mechanical L.L.C. d/b/a/ Feldkamp Enterprises), David Doremus (Marsden Mechanical L.L.C. d/b/a/ Feldkamp Enterprises), Frank Izzo (Marsden Mechanical L.L.C. d/b/a/ Feldkamp Enterprises), Jack Rahn (Marsden Mechanical L.L.C. d/b/a/ Feldkamp Enterprises), Jason Hageman (Marsden Mechanical L.L.C. d/b/a/ Feldkamp Enterprises), Jonathan Vogelpohl (Marsden Mechanical L.L.C. d/b/a/ Feldkamp Enterprises), Josh Zins (Marsden Mechanical L.L.C. d/b/a/ Feldkamp Enterprises), Kelly Jones (Marsden Mechanical L.L.C. d/b/a/ Feldkamp Enterprises), Matt Flower (Marsden Mechanical L.L.C. d/b/a/ Feldkamp Enterprises), Rob Bush (Marsden Mechanical L.L.C. d/b/a/ Feldkamp Enterprises), Shawn Heeney (Marsden Mechanical L.L.C. d/b/a/ Feldkamp Enterprises)		
Description	1.01 SECTION INCLUDES A Roof exhausters. B Roof ventilators. C Roof intake fans. D Wall exhausters. E Cabinet exhaust fans. F Ceiling exhaust fans. G Fire-rated enclosures. H Upblast roof exhausters. I Inline centrifugal fans and blowers. J Kitchen hood upblast roof exhausters. 2.01 MANUFACTURERS A Carnes, a division of Carnes Company Inc B Greenheck Fan Corporation C Loren Cook Company D PennBarry, Division of Air System Components		

Submittal Workflow

Name	Sent Date	Due Date	Returned Date	Response	Attachments
General Information Attachments					
Patrick Tepe		Aug 6, 2025	Aug 1, 2025	Submitted	
Heather Wyatt	Aug 1, 2025	Aug 4, 2025		Pending	
Matt Crawford		Aug 18, 2025		Pending	

Princeton Athletics
GreaseMaster Kitchen Equipment Submittals
Feldkamp Enterprises

Controlled Air, Inc
Patrick Tepe
12009 Tramway Dr
Cincinnati, OH 45241
513-769-6600

7/18/2025

GMDU180H (#1) KEF-1 Weight: 174 lbs./43 curb



High Speed Direct Drive Centrifugal Upblast Exhaust Fan with, disconnect switch and 18-3/4" wheel.

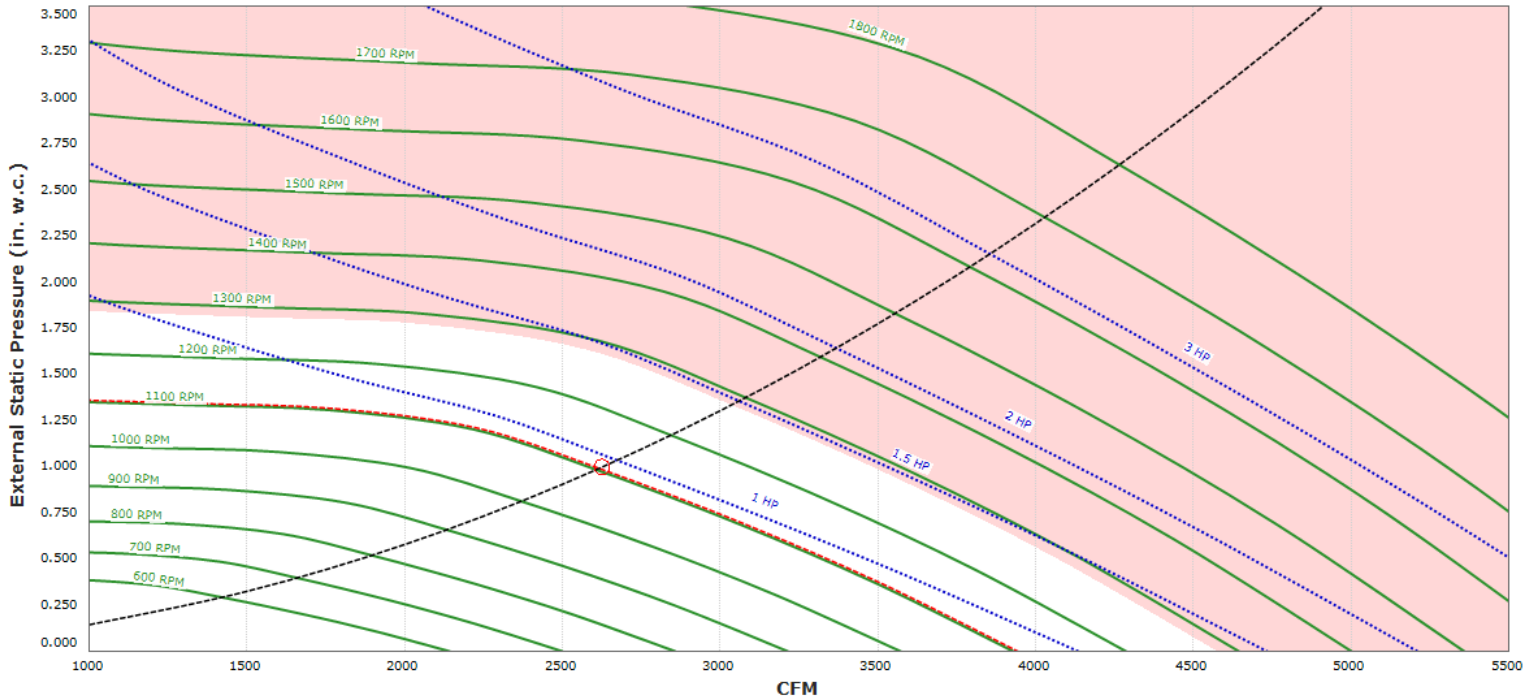

EXHAUST MOTOR

Model DTP0024 • 2.000 HP • 3 Phs • 208 V • 60Hz • 6.1 FLA • ODP, Premium (E-Plus3) Eff.

EXHAUST PERFORMANCE

Volume:	2625 CFM	RPM:	1104	TS:	5419 ft/min
Static Pressure:	1.000" w.g.	BHP:	0.943	Discharge Velocity:	606 FPM
Altitude:	720'	Ambient Temp:	120.0°F	FEI:	1.069

EXHAUST INSTALLATION INFORMATION

Unit Voltage:	3 phs 208 V 60Hz
Unit Main Input:	7.7 Amps MCA • 15 Amps MOP • 208 V • 14 AWG Wire Min.
SCCR:	10 kAmp

CONSTRUCTION FEATURES

- Housing constructed of heavy gauge aluminum
- Centrifugal backward inclined, non-overloading wheel built out of 3003-H14 aluminum
- Weatherproof safety disconnect switch
- Grease spout welded to housing
- Vibration isolators
- Adjustable pitch drive assemblies
- Adjustable motor mount
- Ball bearing motors
- Forces fresh air through motor to ensure long motor life
- Corrosion resistant fasteners
- High heat operation (300 °F)
- Rated for restaurant and general ventilation applications
- Grease classification tested
- UL705 and UL762

CURB & SUPPORTS

- ROOF CURB - 26-1/2" Sq. x 20" High.
- Hinge Kit

CONFIGURED OPTIONS

- Grease Cup for kitchen-duty centrifugal exhaust fans, Box Dimensions 17-1/8 L X 5-1/16 W X 3-3/4 H (20 Gauge) (Includes Down Spout)
- DU/DR180HFA Gasketing Kit - Thermeez Woven Ceramic Tape - 1/4" x 1" with adhesive back - Max Temp 1500°F. To be applied between fan base and grease duct. Installed under fan base 1/2" from the inside. Installed at the plant.
- VAV (Variable-Air-Volume) Wiring Package for Commercial Fans. Manual Speed Control Variable Frequency Drive Included
- Exhaust Variable Frequency Drive - 2 HP Max., 200/240 V, Single or Three Phase Input, 7.0 A Max., NEMA 1 Enclosure PART NEEDS PROGRAMMING
- VFD factory mounted and wired in unit control vestibule.
- VFD Mounting bracket for DU/DR 180 and 200.
- Insulated Heat Baffle for Exhaust Fans. Type 475FRK 1 inch thick insulation installed on the top side of the top plate and under the motor of upblast and downblast fans. Cut to fit shaft wrapper and around vibration isolators and motor cooling hole. Caulked down to top plate.

GMDU180H SOUND (1104 RPM) AT 5 FT. IN OCTAVES:

	1	2	3	4	5	6	7	8	
	74.6	81.6	82.4	72.6	67.9	65.7	59.5	53.2	
LWA:	76.8		Sones:		13.3		DBA:		65.3

Note: Sound data across operational range. Tested in accordance to AHRI Standard 270/370.

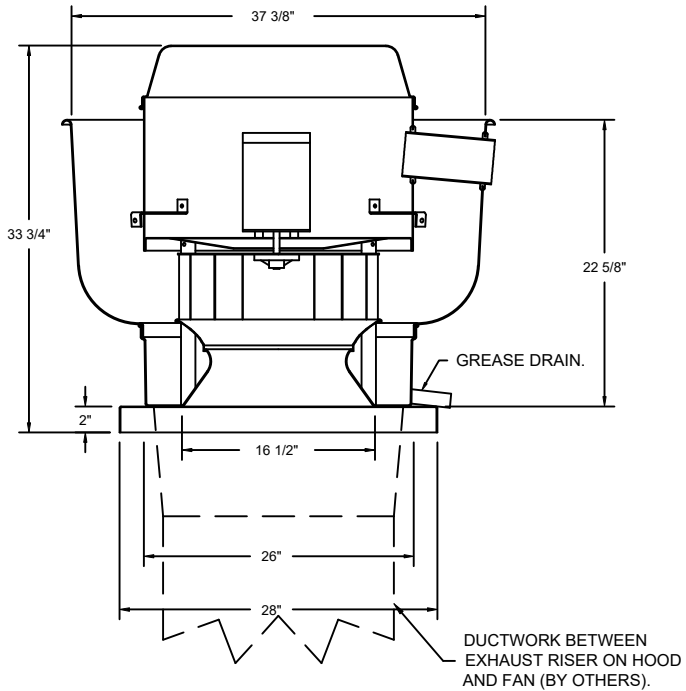

FEATURES:

- DIRECT DRIVE CONSTRUCTION (NO BELTS/PULLEYS).
- ROOF MOUNTED FANS.
- RESTAURANT MODEL.
- UL705 AND UL762 AND ULC-S645
- VARIABLE SPEED CONTROL.
- INTERNAL WIRING.
- THERMAL OVERLOAD PROTECTION (SINGLE PHASE).
- HIGH HEAT OPERATION 300°F (149°C).
- GREASE CLASSIFICATION TESTING.
- NEMA 3R SAFETY DISCONNECT SWITCH.

NORMAL TEMPERATURE TEST
 EXHAUST FAN MUST OPERATE CONTINUOUSLY WHILE EXHAUSTING AIR AT 300°F (149°C) UNTIL ALL FAN PARTS HAVE REACHED THERMAL EQUILIBRIUM, AND WITHOUT ANY DETERIORATING EFFECTS TO THE FAN WHICH WOULD CAUSE UNSAFE OPERATION.

ABNORMAL FLARE-UP TEST
 EXHAUST FAN MUST OPERATE CONTINUOUSLY WHILE EXHAUSTING BURNING GREASE VAPORS AT 600°F (316°C) FOR A PERIOD OF 15 MINUTES WITHOUT THE FAN BECOMING DAMAGED TO ANY EXTENT THAT COULD CAUSE AN UNSAFE CONDITION.

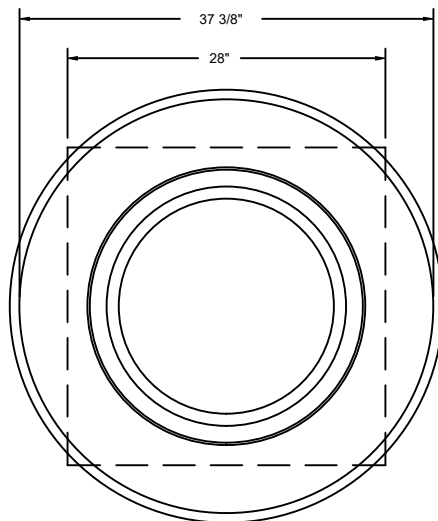
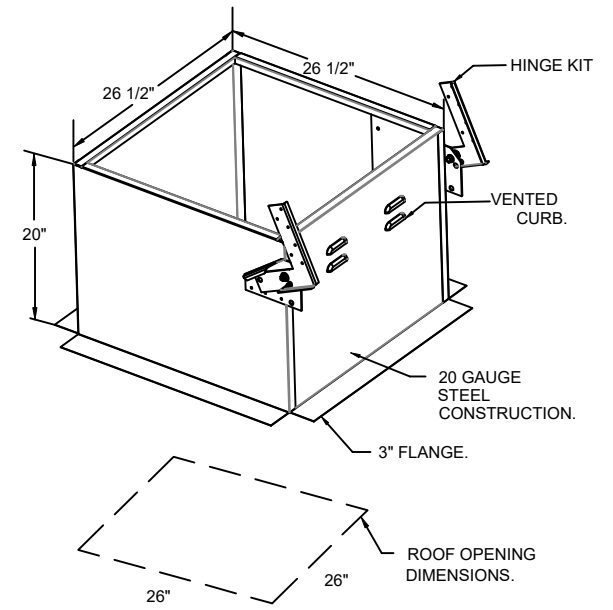

TOP VIEW

Exhaust Fan Wiring

PROJECT Princeton Athletics

DRAWING NUMBER EXH7528070-1

MODEL GMDU180H

Installed Options

1
2
3
4
5
6
7
8
9
10
11
12
13
14
15
16
17
18
19
20
21
22
23

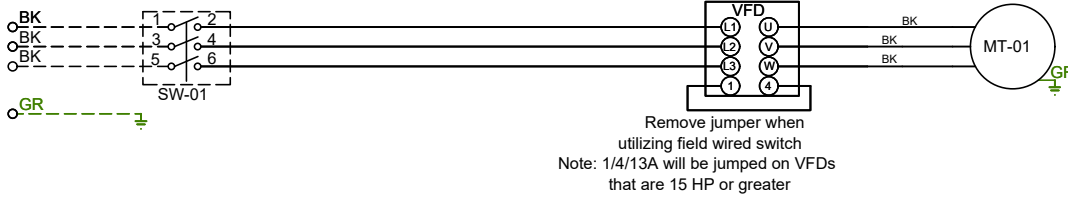

Label	Component Identification	
	Description	Location
MT-01	Fan Motor	[3]
SW-01	Main disconnect switch	[3]

MOTOR INFO
EXHAUST 2.0HP-208V-3P-6.1FLA
VFD PART: ESV152N02YXB

ELECTRICAL INFORMATION
MOTOR/CTRL MCA: 7.7A
MOTOR/CTRL MOP: 15A

NOTES
- - - - DENOTES FIELD WIRING
———— DENOTES INTERNAL WIRING

WIRE COLOR

BK - BLACK	YW - YELLOW
BL - BLUE	GR - GREEN
BR - BROWN	GY - GRAY
OR - ORANGE	PR - PURPLE
RD - RED	PK - PINK
WH - WHITE	

Installed Options
Manual Control

SMV SERIES VARIABLE FREQUENCY DRIVE

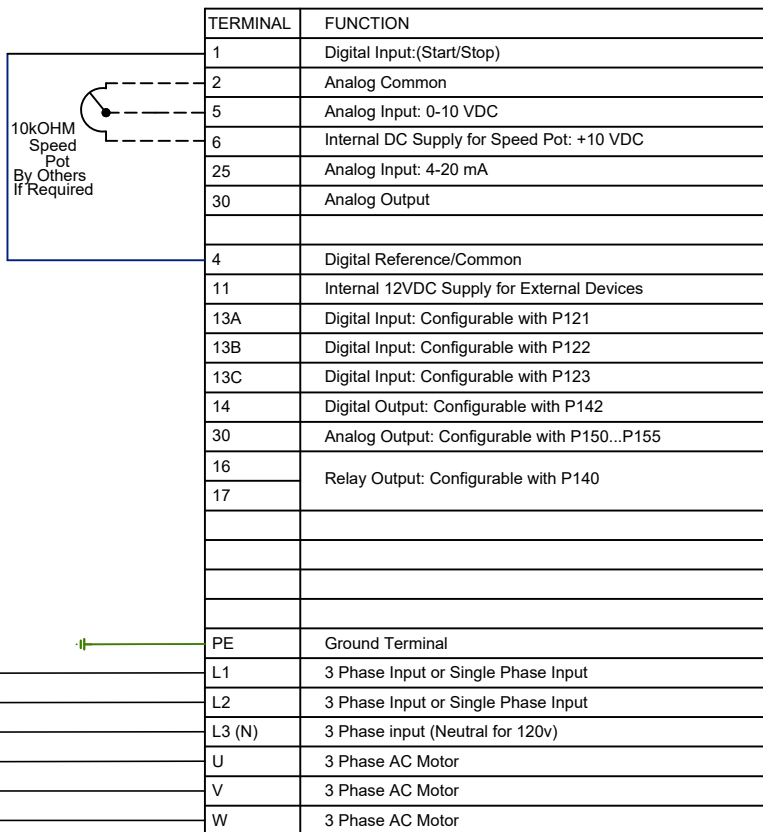

Component Identification

VARIABLE FREQUENCY DRIVE PARAMETER SETTINGS*

All external control wires to motor speed control should be 16-20 AWG shielded multiconductor cables and must not be run in the same conduit or raceway with any high power wiring. Ground Shielded Cable at the drive chassis ONLY.

PG. 11 OF THE DRIVE MANUAL DESCRIBES THE PROPER INSTALLATION PROCEDURE

PG. 19 OF THE DRIVE MANUAL DESCRIBES THE PROGRAMMING PROCEDURE OF THE DRIVE

PG. 23 OF THE DRIVE MANUAL DESCRIBES THE PARAMETER SETTINGS OF THE DRIVE

*NOTE: THE DEFAULT PASSWORD FROM THE FACTORY REQUIRED TO PROGRAM THE DRIVE IS "225".

EPM PROGRAM: VAV_MAN(USE LG_HP EPM IF >= 15HP)
 P100 (Start Source) = 01 (Terminal Strip)
 P102 = **Minimum Frequency (Hz)
 P103 = **Maximum Frequency (Hz)
 (P103 is based on max wheel RPM)
 P110 (Start Method) = 03 (Auto Re-start)
 P140 (Form A [NO] Relay) = 01 (Run)
 P144 (Relay Inversion) = 00 (None)
 P166 (Carrier Frequency) = 00 (4 kHz)
 P171 (Current Limit) = P108 - 1

Adjust manually on all drives
 P107 - 00 (If 120 or 208 VAC)
 or 01 (If 230, 480 or 575 VAC)
 P108 - Motor FLA x 100 / Drive Output Rating
 P165 (Base Voltage) = Set to Motor Voltage (Preset@230V) P165 FOR STANDARD DRIVE ONLY
 P167 (Base Frequency) = Calculated Per Fan

FOR KB PCU ONLY: P300 = 0

When Speed POT is Required the Following Parameters Must be Set:

P101 (Reference Source) = 01 (0-10 VDC)
 P160 (Speed @ 0 VDC Signal) = Min Frequency
 P161 (Speed @ 10 VDC Signal) = Max Frequency

IT MAY BE REQUIRED TO FULLY POWER DOWN THE DRIVE AND TURN BACK ON IN ORDER TO INITIATE NEW PARAMETER SETTINGS.

**Min. and Max. Frequency Settings override all other Preset speeds/Parameters.

GENERAL NOTES

***Note: Not Suitable for Corner Grounded 3 Phase Input power**

MOTOR INFO
 EXHAUST 2.0HP-208V-3P-6.1FLA
 VFD PART: ESV152N02YXB

ELECTRICAL INFORMATION
 MOTOR/CTRL MCA: 7.7A
 MOTOR/CTRL MOP: 15A

NOTES

----- DENOTES FIELD WIRING
 _____ DENOTES INTERNAL WIRING

WIRE COLOR

BK - BLACK YW - YELLOW
 BL - BLUE GR - GREEN
 BR - BROWN GY - GRAY
 OR - ORANGE PR - PURPLE
 RD - RED PK - PINK
 WH - WHITE

GMRTU1-I.200-15 (#2)
MAU-1
Weight: 937 lbs./103 curb

RTU with Indirect Fired Heat and 15" Direct Drive Plenum Fan, 1 Furnace, Electronic Full Modulation, Constant 81% Efficiency, and 6:1 Max Turndown for NG, (5:1 Max Turndown for LP). Stainless Steel Burner and Heat Exchanger.

SUPPLY MOTOR

Model DTP1/54 • 1.500 HP, 3 Phs, 208 V, 60 Hz, 4.4 FLA, ODP, Premium (E-Plus3) Eff.

SUPPLY PERFORMANCE

Supply Air:	2100 CFM	RPM:	1324
Return Air:	0 CFM	Outdoor Air:	2100 CFM
Tip Speed:	5199 ft/min	BHP:	0.8520
SP:	0.784" w.g. (0.390" Ductwork Discharge ESP + 0.394" Opt.)		
Altitude:	720 ft		

HEATING SCHEDULE

Altitude:	720 ft
Winter Outdoor Air Dry Bulb Temp:	10.0°F
Temp Rise:	65.0°F
Output BTU:	162,000 BTU/Hr
Input BTU:	200,000 BTU/Hr
Based Off:	BTUs Actual Air Density
Gas Type:	Natural

BLOWER

15 Inch Plenum Fan for size 1 RTU. Hub specified to match motor shaft.

TEMPERATURE CONTROL

CORRIDOR/GENERAL NEUTRAL VENTILATION • Discharge Temp Control • Heating and Cooling Activation Based On Intake Set Point • Manual Blower Mode • 100% Outdoor Air Freezestat • Smoke Detector Interlock • Additional HMI Ships Loose. Use with MUA.

AIRFLOW DIRECTION

- Side Discharge - Air Flow Left -> Right

CURB & SUPPORTS

- ROOF CURB - 41" Width, 71" Length, 20" Supply Height, Insulated

SUPPLY INSTALLATION INFORMATION

Gas Pressure:	7 in. w.c. - 14 in. w.c.
Insurance Requirements:	No Insurance Requirement (ANSI)
Unit Voltage:	3 phs 208 V 60Hz
Unit Main Input:	8.1 Amps MCA • 15 Amps MOP • 208 V • 14 AWG Wire Min.
SCCR:	10 kAmp

CONFIGURED OPTIONS

- Gas Pressure Gauge, 0-35", 2.5" Diameter, 1/4" Thread Size
- Gas Pressure Gauge, 0 to +10 Inches Wc., 2.5" Diameter, 1/8" Thread Size, Rear Thread
- Cooling Override
- Single Point Electrical Connection for RTU. QNTY 1 750va Transformer Used. If a Non-DCV Prewire controls this unit, the #28, #47, "MA", or "E2" Option Prewire must be selected. Do not provide supply starter in prewire.
- Unit will be shipped with construction mode ON. This is used to provide tempering for a building in construction. Activation is set to Intake, Tempering is set to Discharge, Mixing Box is set to 100% OA and HMI number is 1.
- RTU Blower Door Switch. Used to turn on DOOR INTERLOCK Schematic Layer. Does Not Include Door Switch.
- 2" Merv 8 Filters for Size 1 RTU. QTY 4, 16 x 16 x 2 Merv 8 Filters
- Overheat Stat factory set at 80°F and 10 minutes. Prevents unit from overheating the space when cooling.
- CFM monitoring for MUA units. Uses rivet nuts, 1/4" airflow tubing and push to connect fittings.
- VFD factory mounted and wired in unit control vestibule.
- RTU Fixed 100% Outdoor Air Intake.
- Discharge Firestat. Set to 240°F
- Freezestat
- Intake Firestat. Set to 135°F
- CASLink building monitoring system communications module. Requires internet & field wired ethernet connection or 3G cellular service. Includes Rev 3 Comm Module, RJ45 to modbus converter, 3 FT cat5 cable, and 1 FT of shielded twisted pair.
- Commercial Smoke Detector Interlock (Detector By Others)
- Size 1 RTU Curb Duct Hanger - Adjustable Duct Hanger Support Brackets installed for both return and discharge duct.
- Size 1 RTU No Cooling Option.
- RTU Size 1 No Return - Heat Only
- 2" Merv 13 Filters for Size 1 RTU. QTY 4, 16 x 16 x 2 Merv 13 Filters
- Option for Metal Mesh Filters in RTU1 OA Intakes
- VAV (Variable-Air-Volume) Wiring Package for Commercial Fans. Manual Speed Control Variable Frequency Drive Included
- Supply Variable Frequency Drive - 1-1/2 HP Max., 200/240 V, Single or Three Phase Input, 6.0 A Max., NEMA 1 Enclosure, with 2RJ-45 FOR MODBUS
- RTU Size 1 Side Discharge
- Remote MSTP BACnet monitoring

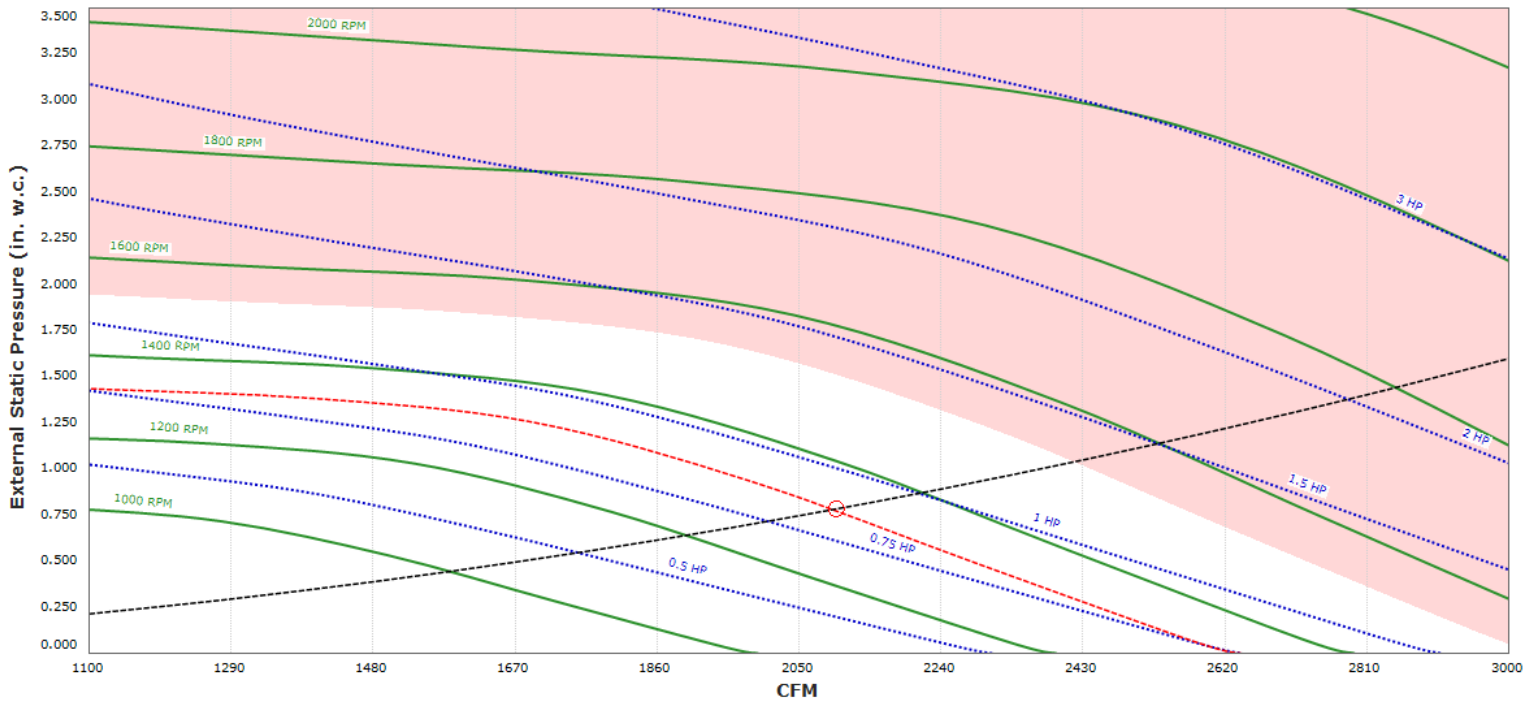

GMRTU1-I.200-15 SOUND (1324 RPM) AT 5 FT. IN OCTAVES:

	1	2	3	4	5	6	7	8	
	81.8	81.6	78.1	75.4	75.7	72.2	69.6	71.6	
LWA:	80.4		Sones:		19.5		DBA:		70.1

Note: Sound data across operational range. Tested in accordance to AHRI Standard 270/370.

NOTES:

1. ROOF OPENING MUST BE 2" SMALLER THAN CURB DIMENSIONS IN BOTH DIRECTIONS.
2. DO NOT OBSTRUCT OUTSIDE AIR INLET, OUTSIDE AIR COIL OR OUTSIDE AIR FAN.
3. FLOOR MOUNT ISOLATORS LOCATED 1" FROM END OF BASE IN EITHER DIRECTION. ACCOUNT FOR AN ADDITIONAL 5" FOR ISOLATOR HEIGHT.
4. QUANTITIES SUBJECT TO CHANGE DEPENDING ON FILTER TYPES.
5. ONLY APPLICABLE FOR INDIRECT HEAT, HOT WATER COIL, OR ELECTRIC HEAT CONFIGURATIONS.
6. DIMENSIONS HD1, HD2, GIHE1, AND GIHE2 APPLY ONLY FOR HIGH EFFICIENCY FURNACES, FD1, FD2, F11, AND F12 APPLY ONLY FOR STANDARD EFFICIENCY FURNACES.
7. EXTERIOR GAS CONNECTION PROVIDED BY FACTORY WITH QUICK SEAL AND ANTI-ROTATION BRACKET.

*NOTE: SUPPLY DUCT MUST BE INSTALLED TO MEET SMACNA STANDARDS. A MINIMUM STRAIGHT DUCT LENGTH MUST BE MAINTAINED DOWNSTREAM OF UNIT DISCHARGE AS OUTLINED IN AMCA PUBLICATION 201. WHEN USING RECTANGULAR DUCTWORK, ELBOWS MUST BE RADIUS THROAT, RADIUS BACK WITH TURNING VANES. FLEXIBLE DUCTWORK AND SQUARE THROAT/SQUARE BACK ELBOWS SHOULD NOT BE USED. ANY TRANSITION AND/OR TURNS IN THE DUCTWORK WILL CAUSE SYSTEM EFFECT. SYSTEM EFFECT WILL DRASTICALLY INCREASE STATIC PRESSURE AND REDUCE AIRFLOW. DO NOT RELY ON UNIT TO SUPPORT DUCT IN ANY WAY. FAILURE TO PROPERLY SIZE DUCTWORK MAY CAUSE SYSTEM EFFECTS AND REDUCE PERFORMANCE OF THE EQUIPMENT. SUGGESTED STRAIGHT DUCT SIZE IS 15.5" x 19.25".

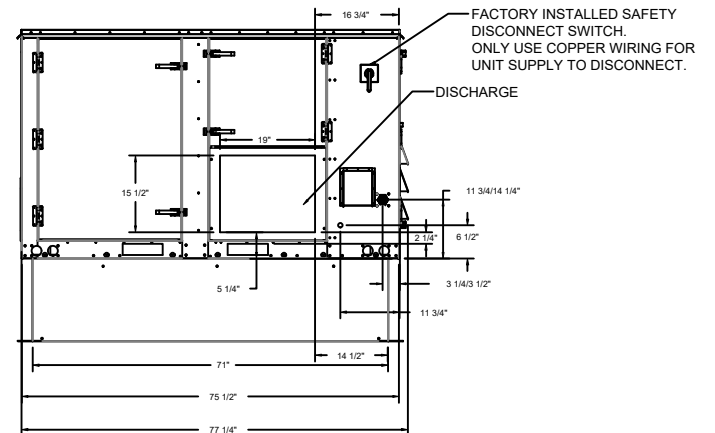
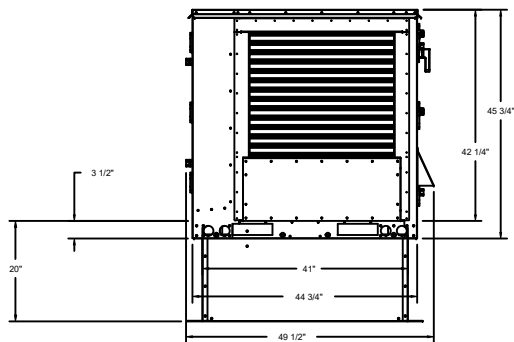
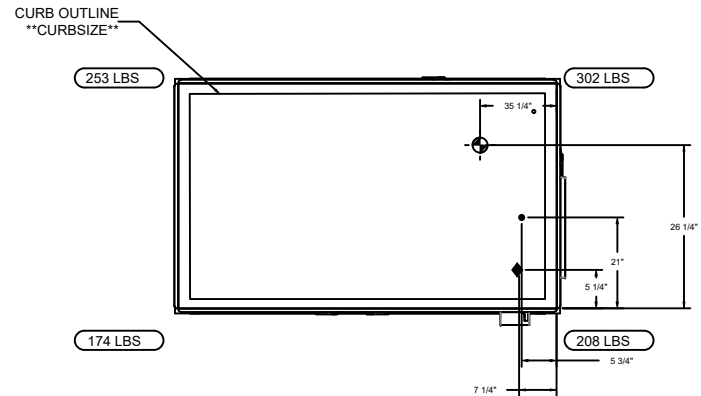
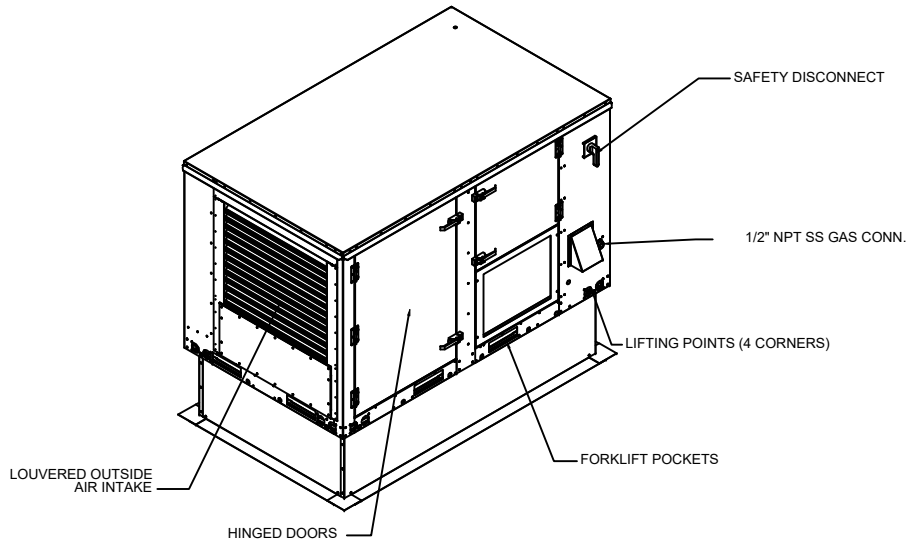

Fan #2 Curb
ROOF CURB - 41" Width, 71" Length, 20" Supply Height, Insulated

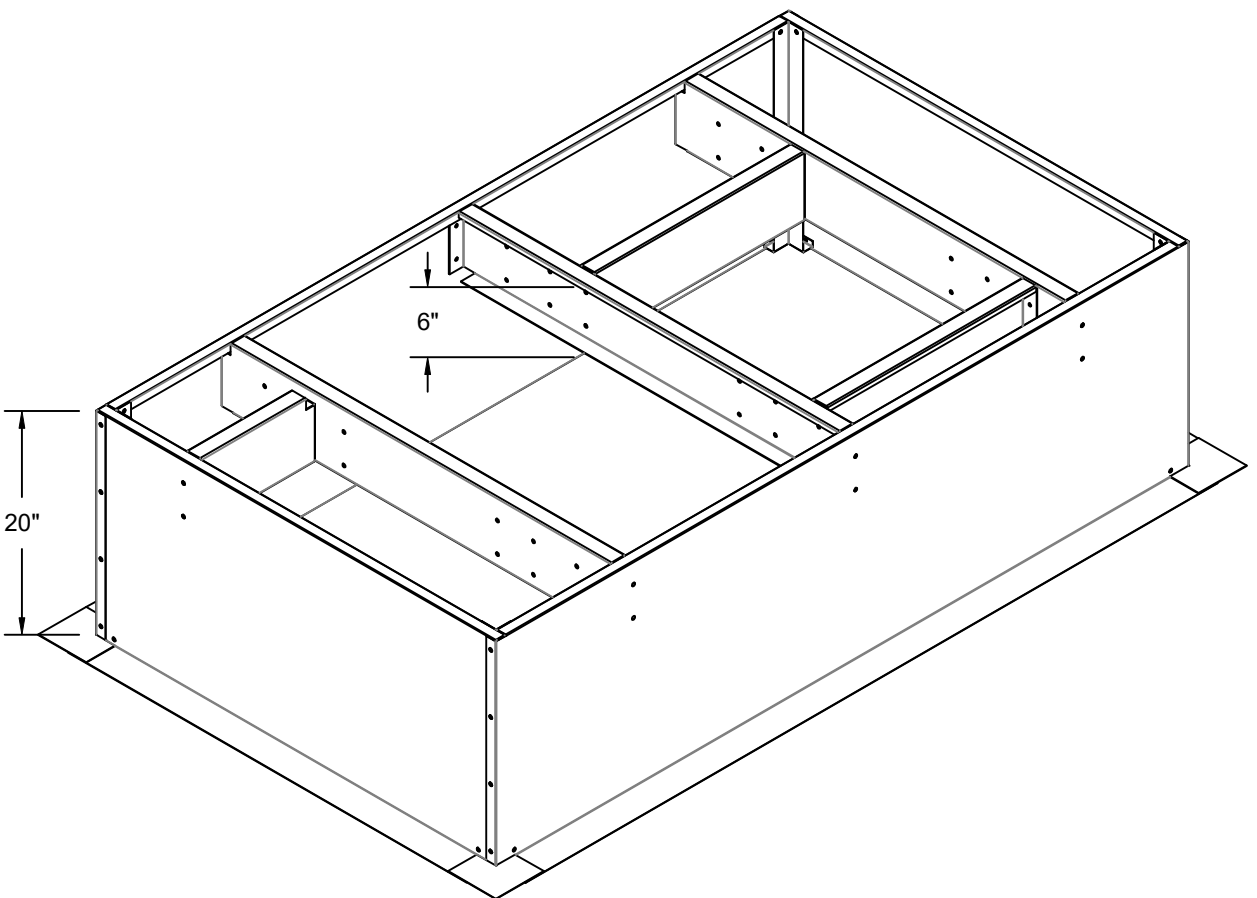
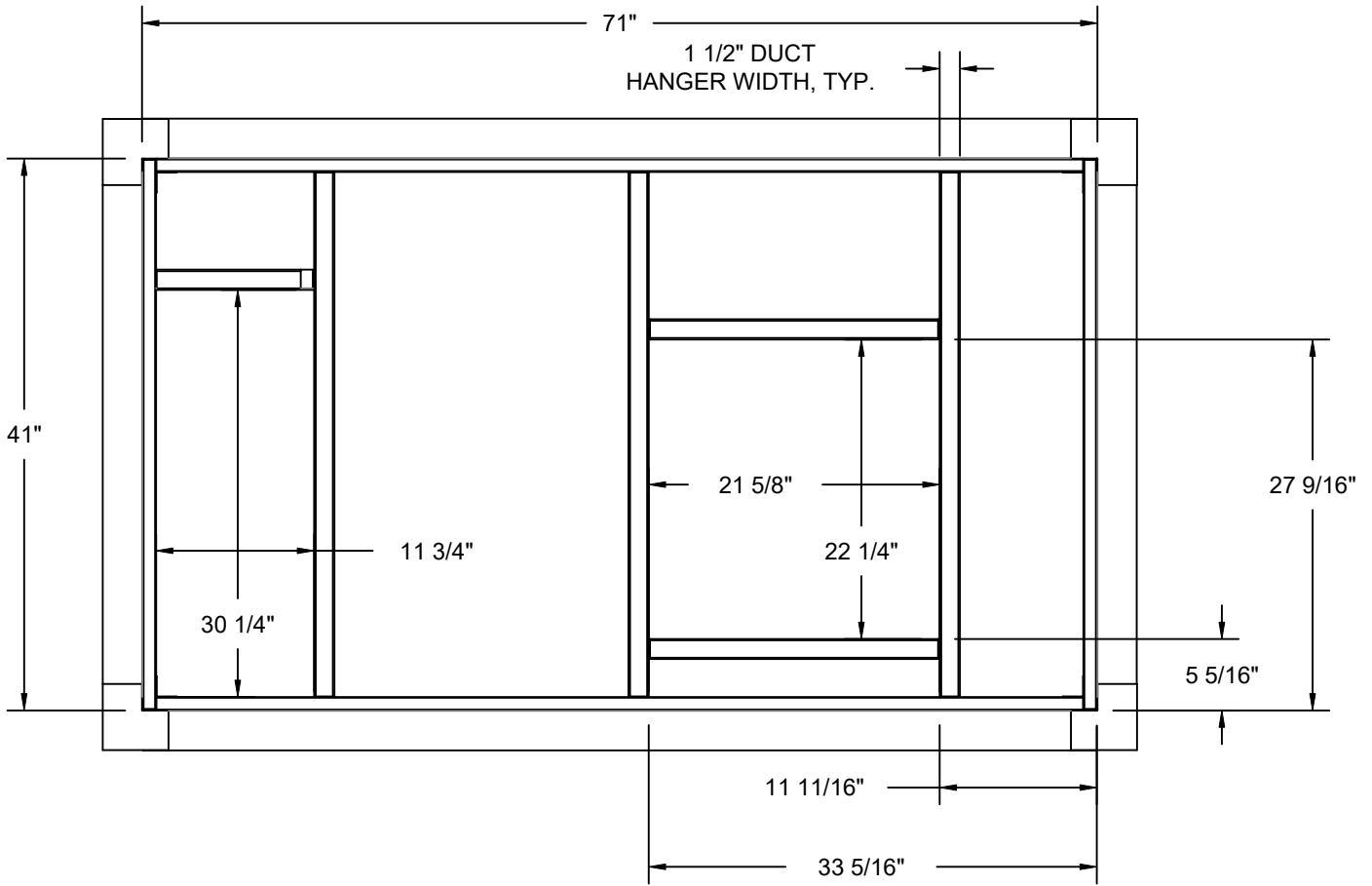

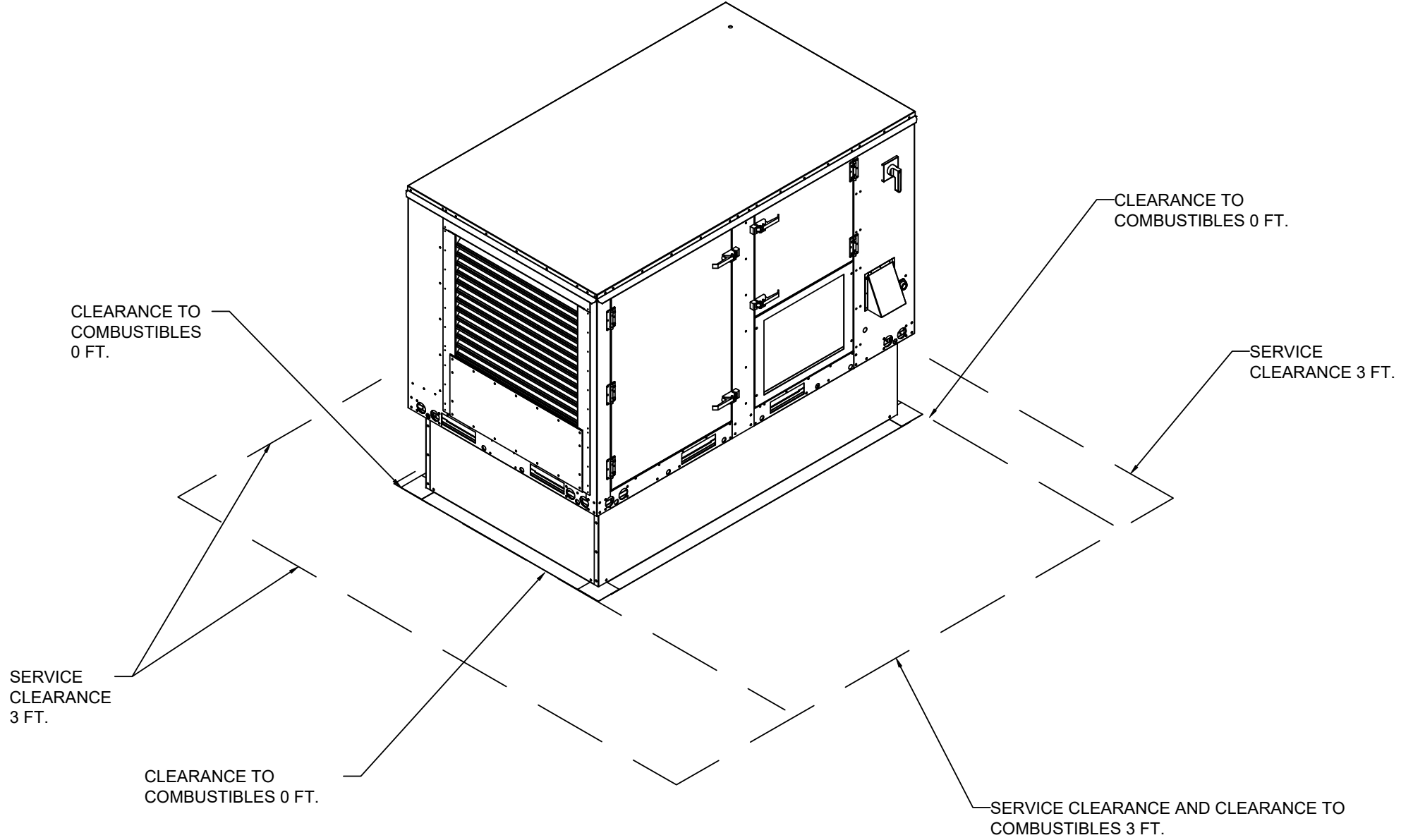

HEAT ONLY SIZE 1

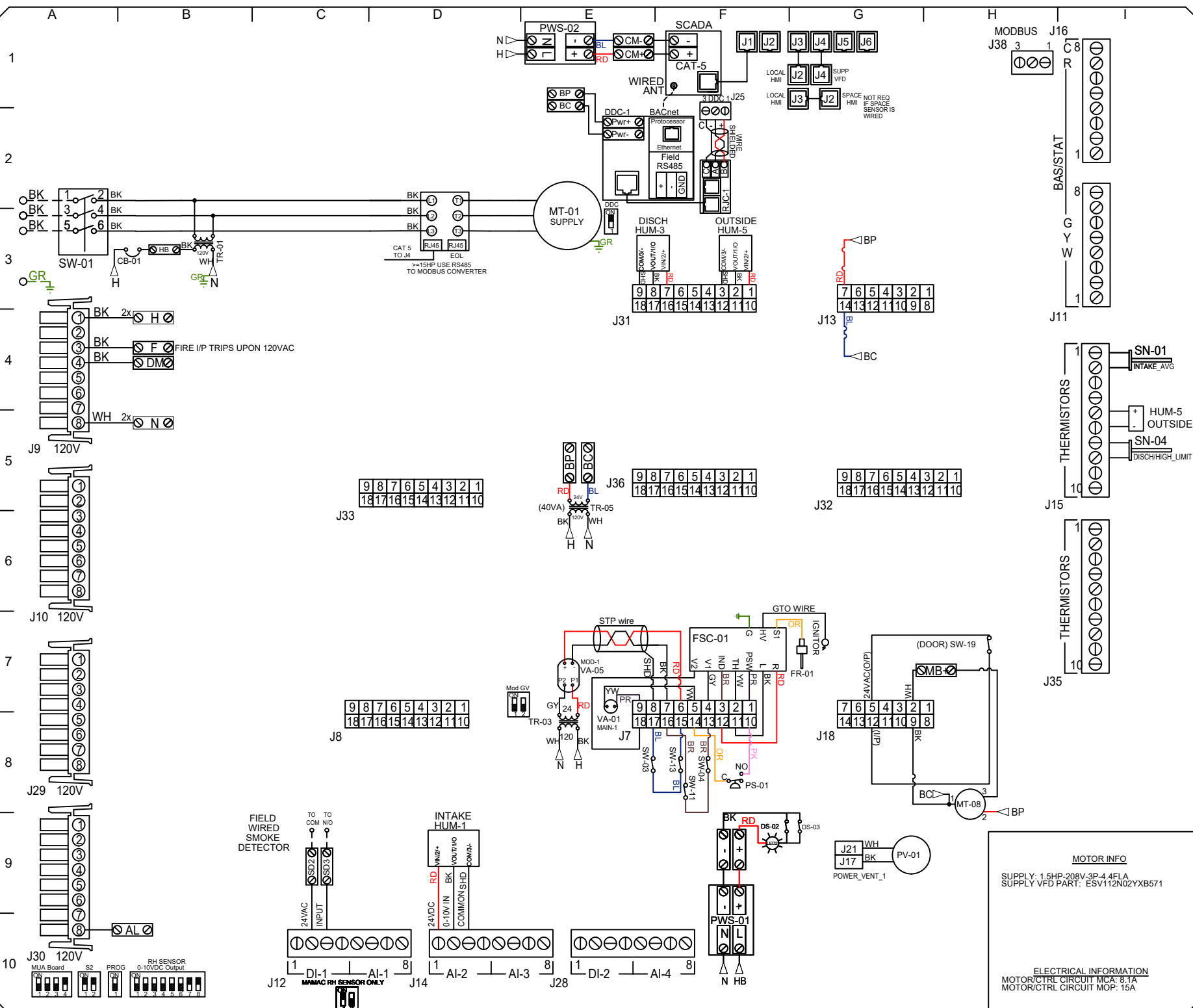

COMPONENT LIST		
LABEL	DESCRIPTION	
CB-01	CIRCUIT_BREAKER	B3
SCADA	SCADA_COMM_MODULE	F1
DS-XX	ELEC_DOOR_SWITCH	F9
FR-01	FLAME_ROD	G7
FSC-01	FLAME_SAFETY_CTLR	C7
HUM-XX	HUM/TEMP_SEN	F3/F9/E4/D9
LED-XX	CAB_LED_STRIP	F9
MT-01	SUPPLY_MOTOR	E3
LED-XX	CAB_LED_STRIP	F9
MT-08	MB_DAMPER_MTR	H8
PS-01	VENT_PROVING_1	F8
PV-XX	FURNACE_POWER_VENT	G9/H10
SD-01	SMOKE_DETECTOR	C9
SN-XX	TEMP_SENSOR	I4/I5/I6/I7
SW-01	DISCONNECT_SWITCH	A3/B8
SW-03	ROLL_OUT_1-1	F8
SW-04	FURN_HIGH_TEMP_1-1	F8
SW-11	FURN_HIGH_TEMP_1-2	F8
SW-13	ROLL_OUT_1-2	F8
SW-19	DOOR_SWITCH	H7
TR-01	CTRL_TRANSFMR	B3
TR-03	MOD_VALVE_TRFMR_1	E8
TR-05	BOARD_POWER_TRFMR	E5
VA-01	MAIN_GAS_VALVE	E7
VA-05	MOD_GAS_VALVE	E7
VFD-01	SUPPLY_FAN_VFD	D3

LEGEND	
---	FIELD WIRING
---	FACTORY WIRING
BK	BLACK
YW	YELLOW
BL	BLUE
GY	GREY
BR	BROWN
PR	PURPLE
OR	ORANGE
RD	RED
WH	WHITE
GR	GREEN
OR/BL	OR/BL STRIPE
BL/RD	BL/RD STRIPE
RD/GR	RD/GR STRIPE
WH/BL	WH/BL STRIPE

MOTOR INFO
 SUPPLY: 1.5HP-208V-3P-4 FLA
 SUPPLY VFD PART: ESV112N02YXB571

ELECTRICAL INFORMATION
 MOTOR/CTRL CIRCUIT MCA: 8.7A
 MOTOR/CTRL CIRCUIT MOP: 15A

JOB NAME Princeton Athle...	
DRAWING TITLE	
DESCRIPTION OF OPERATION MUA BOARD (DETAILS TO FOLLOW)	
JOB NO 7528070	DRAWN BY AUTO
TYPE FACTORY	DATE 5/13/2025
DWG NO HW7528070-2	

SUPPLY DRIVE PARAMETER SETTINGS

P100	(START SOURCE) = 01 (TERMINAL STRIP)
P150	(TB-30 OUTPUT) = 1
P194	PASSWORD = 225
P410	MODBUS ADDRESS = 21

ADJUST MANUALLY ON ALL DRIVES	
P103	VFD MAX FREQUENCY
P107	00 (IF 120 OR 208 VAC) OR 01 IF(230, 480 OR 575VAC)
P108	MOTOR FLA X 100 / DRIVE OUTPUT RATING
P167	REFERENCE BUILD SHEET
P171	P108 - 1

SMV 571 SERIES VFD

Terminal	Description
1	Digital Input(Start/Stop)
11	Internal DC Supply for External Devices
2	Analog Common
30	Analog Output:Configurable with P150..P155
RJ45	MODBUS COMMUNICATION
PE	Ground Terminal
L1	3 Phase Input or Single Phase Input
L2	3 Phase Input or Single Phase Input
L3 (N)	3 Phase Input (Neutral for 120v)
U	3 Phase AC Motor
V	3 Phase AC Motor
W	3 Phase AC Motor

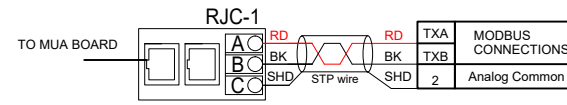

FOR SUPPLY FAN VFD's LARGER THAN 15HP USE RS485 TO MODBUS CONVERTER

*NOTE: THE DEFAULT FOR THE DRIVE IS "225".

All external control wires to motor speed control should be 16-20 AWG shielded multi-conductor cables and must not be run in the same conduit or raceway with any high power wiring. Ground Shielded Cable at the drive chassis ONLY.

PG. 11, 19, 23 OF THE DRIVE MANUAL DESCRIBES THE PROPER HANDLING OF THE VARIABLE FREQUENCY DRIVE.

IT MAY BE REQUIRED TO FULLY POWER DOWN THE DRIVE AND TURN BACK ON IN ORDER TO INITIATE NEW PARAMETER SETTINGS.

**Min. and Max. Frequency Settings override all other Preset speeds/Parameters. Do not adjust these on the VFD. Min. and Max. Frequency should be adjust on the RTU HMI.

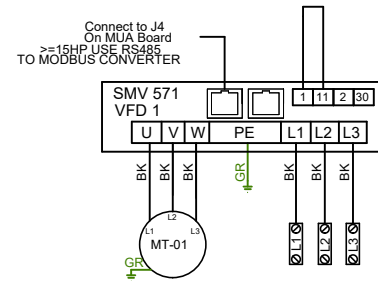

*Note: Not Suitable for Corner Grounded 3 Phase Input power

*Changing 8-30 will reset 8-01 and 8-03 if programmed after 8-01 and 8-03 are set

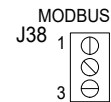

MOTOR INFO

SUPPLY: 1.5HP-208V-3P-4.FLA
SUPPLY VFD PART: ESV112N02YXB571

ELECTRICAL INFORMATION
MOTOR/CTRL CIRCUIT MCA: 8.1A
MOTOR/CTRL CIRCUIT MOP: 15A

RTU VFD SCHEMATIC

COMPONENT LIST

LABEL	DESCRIPTION
MT-01	Supply Motor
PWS-01	24VDC Power Supply
VFD-1	Supply Motor VFD

LEGEND

-----	FIELD WIRING
-----	FACTORY WIRING
BK-BLACK	YW-YELLOW
BL-BLUE	GY-GREY
BR-BROWN	PR-PURPLE
OR-ORANGE	RD-RED
WH-WHITE	GR-GREEN
OR/BL-OR/BL STRIPE	
BL/RD-BL/RD STRIPE	
RD/GR-RD/GR STRIPE	
WH/BL-WH/BL STRIPE	

JOB NAME
Princeton Athle...

DRAWING TITLE

DESCRIPTION OF OPERATION
MUA BOARD (DETAILS TO FOLLOW)

JOB NO	DRAWN BY
7528070	AUIQ
TYPE	DATE
FACTORY	5/13/2025

DWG RTU VFD 7528070-2

*Must be programmed using software

Installed Options

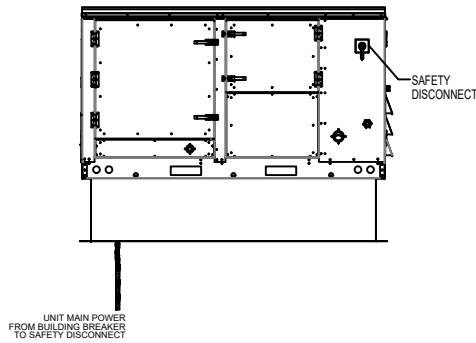

HMI SCHEDULE				
UNIT NUMBER	HMI #	HMI LOCATION	TEMP AVERAGING	MODBUS ADDRESS
FAN #2	HMI #1 - UNIT	IN UNIT	NOT AVERAGED	55
FAN #2	HMI #2 - SPACE		NOT AVERAGED	56

UNIT MAIN POWER FROM BUILDING BREAKER TO SAFETY DISCONNECT

BREAKER TO PRIMARY DISCONNECT

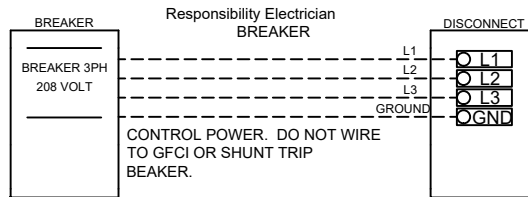

UNIT BOARD TO SMOKE DETECTOR
Responsibility Electrician

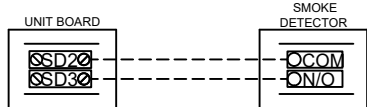

CAS BACNET TO BACNET MASTER
Responsibility Electrician

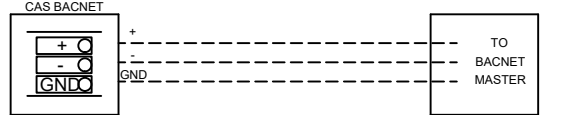

NOTES

--- Field Wiring

WIRE COLOR

- BK - BLACK
- BL - BLUE
- BR - BROWN
- OR - ORANGE
- RD - RED
- WH - WHITE
- YW - YELLOW
- GR - GREEN
- GY - GRAY
- PR - PURPLE
- PK - PINK