



SUBMITTAL

PROJECT: URGENT VET – MATTHEWS TOWNSHIP
MATTHEWS, NC

ENGINEER: NELSON
CINCINNATI, OH

CONTRACTOR: ACTION MECHANICAL CONTRACTORS
CHARLOTTE, NC

EQUIPMENT: EXHAUST FANS & HOODS BY LOREN COOK

SUPPLIER: HAHN-MASON AIR SYSTEMS, INC.
4901 DWIGHT EVANS ROAD, STE. 120
CHARLOTTE, NORTH CAROLINA 28217

SUBMITTED BY:

A handwritten signature in black ink that reads "David Petrovski". The signature is written in a cursive style and is positioned above a horizontal line.

David Petrovski

HAHN-MASON AIR SYSTEMS, INC.
P.O. BOX 31248
CHARLOTTE, NC 28231-1248

Telephone: 704-523-5000
Fax: 704-523-5171
01/18/2023 4:23 PM



COOK



MARK: EF-1

PROJECT: URGENT VET - MATTHEWS

DATE: 1/18/2023

E102, E103

GEMINI Vari-Flow®

Inline Blowers 300, 500, 700 Series

STANDARD CONSTRUCTION FEATURES:
 Forward curved galvanized steel fan wheel -
 Corrosion resistant galvanized steel fan housing -
 Acoustically insulated housing - Aluminum backdraft damper with solid aluminum hinge rod mounted in nylon bushings - Permanently lubricated variable speed electronically commutated motor with built-in electronic overload protection and disconnect plug - Interchangeable panels with removable fasteners allows the intake to be easily changed - Internal wiring box with disconnect receptacle

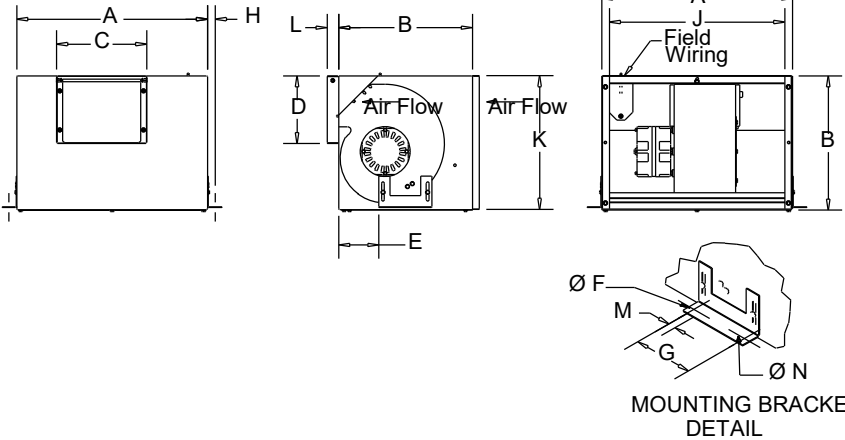

Performance

Qty	Catalog Number	Flow (CFM)	SP (inwc)	Nominal RPM	Input Watts	Speed Control
2	GNVF-340	70	.375	1447	10	EC

Altitude (ft): 768 Temperature (F): 70

Motor Information

Volts/Ph/Hz	Nameplate Amps
115/1/60	1.2



Motor is electronically/thermally protected.

Sound Data Inlet Sound Power by Octave Band

1	2	3	4	5	6	7	8	LwA	dBA	Sones
54	56	56	49	43	38	34	29	51	40	2.0

- Distance from Sound source 5 ft

Accessories:

- EXT SPD CTRL CAPABLE
- CONTROL BY OTHERS
- GEMINI ISOLATOR KIT - ISOLATORS

Dimensions (inches)

A	12-3/8	K-Inlet	10-11/16
B	10-7/8	M	1/2
C-Outlet	8	N	3/16
D-Outlet	6		
L	1		
E	3-9/16		
F	1/2		
G	4		
H	13/16		
J-Inlet	12-5/16		

NOTE: Accessories may affect dimensions shown.

Weight(lbs)***	Shipping	34	Unit	30
----------------	----------	----	------	----

***Includes fan, motor & accessories.

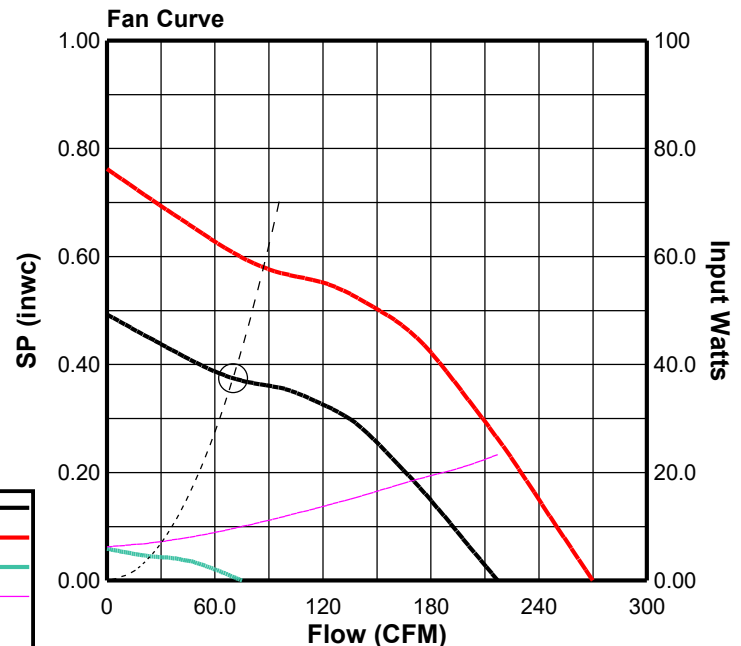

Fan Curve Legend

CFM vs SP (1447)	—
100% EC (1800)	—
Min EC (500)	—
CFM vs Watts	—
Point of Operation	○
System Curve	- - -



COOK



MARK: EF-2

PROJECT: URGENT VET - MATTHEWS

DATE: 1/18/2023

GEMINI Vari-Flow®

Inline Blowers 300, 500, 700 Series

STANDARD CONSTRUCTION FEATURES:
 Forward curved galvanized steel fan wheel -
 Corrosion resistant galvanized steel fan housing -
 Acoustically insulated housing - Aluminum backdraft damper with solid aluminum hinge rod mounted in nylon bushings - Permanently lubricated variable speed electronically commutated motor with built-in electronic overload protection and disconnect plug - Interchangeable panels with removable fasteners allows the intake to be easily changed - Internal wiring box with disconnect receptacle

E101, E104, E105, E106, E107, E108

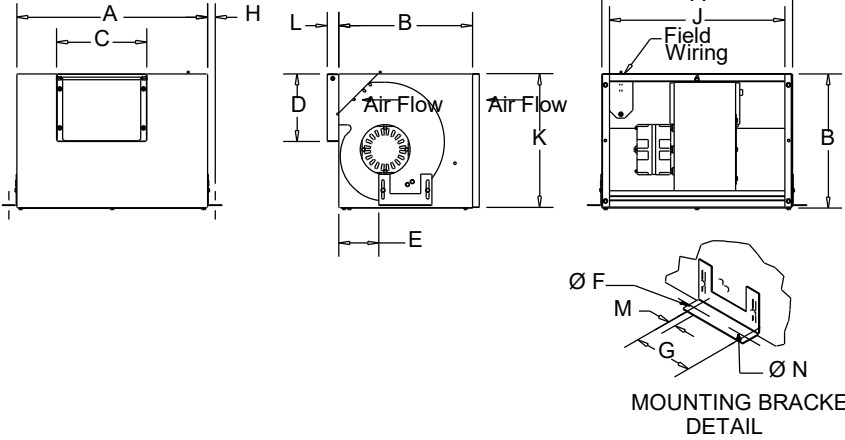

Performance

Qty	Catalog Number	Flow (CFM)	SP (inwc)	Nominal RPM	Input Watts	Speed Control
6	GNVF-340	100	.375	1486	13	EC

Altitude (ft): 768 Temperature (F): 70

Motor Information

Volts/Ph/Hz	Nameplate Amps
115/1/60	1.2



Motor is electronically/thermally protected.

Sound Data Inlet Sound Power by Octave Band

1	2	3	4	5	6	7	8	LwA	dBA	Sones
54	57	57	50	44	39	34	30	52	41	2.0

- Distance from Sound source 5 ft

Accessories:

CONTROL BY OTHERS
 EXT SPD CTRL CAPABLE
 GEMINI ISOLATOR KIT - ISOLATORS

Dimensions (inches)

A	12-3/8	K-Inlet	10-11/16
B	10-7/8	M	1/2
C-Outlet	8	N	3/16
D-Outlet	6		
L	1		
E	3-9/16		
F	1/2		
G	4		
H	13/16		
J-Inlet	12-5/16		

NOTE: Accessories may affect dimensions shown.

Weight(lbs)***	Shipping	34	Unit	30
----------------	----------	----	------	----

***Includes fan, motor & accessories.

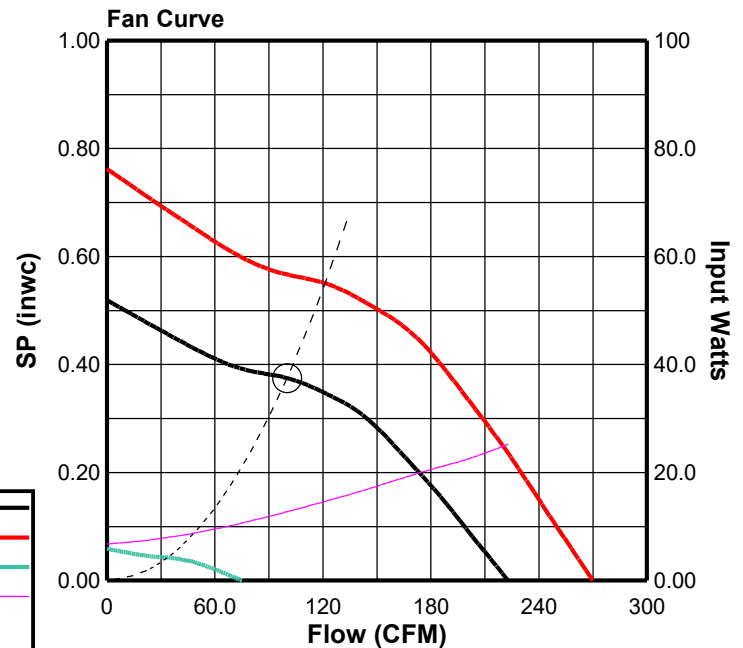

Fan Curve Legend

CFM vs SP (1486)	—
100% EC (1800)	—
Min EC (500)	—
CFM vs Watts	—
Point of Operation	○
System Curve	---



COOK



MARK: EF-3
PROJECT: URGENT VET - MATTHEWS
DATE: 1/18/2023

E109

GEMINI Vari-Flow®

Inline Blowers 300, 500, 700 Series

STANDARD CONSTRUCTION FEATURES:
 Forward curved galvanized steel fan wheel -
 Corrosion resistant galvanized steel fan housing -
 Acoustically insulated housing - Aluminum backdraft damper with solid aluminum hinge rod mounted in nylon bushings - Permanently lubricated variable speed electronically commutated motor with built-in electronic overload protection and disconnect plug - Interchangeable panels with removable fasteners allows the intake to be easily changed - Internal wiring box with disconnect receptacle

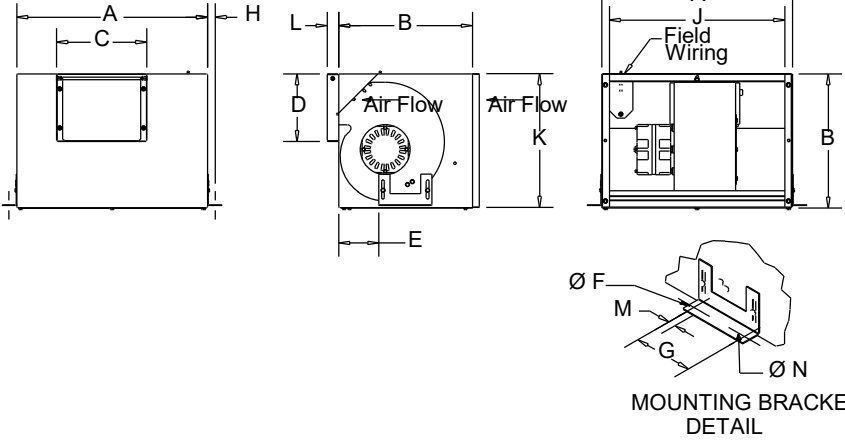

Performance

Qty	Catalog Number	Flow (CFM)	SP (inwc)	Nominal RPM	Input Watts	Speed Control
1	GNVF-340	150	.375	1617	21	EC

Altitude (ft): 768 Temperature (F): 70

Motor Information

Volts/Ph/Hz	Nameplate Amps
115/1/60	1.2



Motor is electronically/thermally protected.

Sound Data Inlet Sound Power by Octave Band

1	2	3	4	5	6	7	8	LwA	dBA	Sones
55	58	61	52	46	40	36	31	55	44	2.5

- Distance from Sound source 5 ft

Accessories:

- CONTROL BY OTHERS
- EXT SPD CTRL CAPABLE
- GEMINI ISOLATOR KIT - ISOLATORS

Dimensions (inches)

A	12-3/8
B	10-7/8
C-Outlet	8
D-Outlet	6
L	1
E	3-9/16
F	1/2
G	4
H	13/16
J-Inlet	12-5/16

K-Inlet	10-11/16
M	1/2
N	3/16

NOTE: Accessories may affect dimensions shown.

Weight(lbs)***	Shipping 34	Unit 30
-----------------------	--------------------	----------------

***Includes fan, motor & accessories.

Fan Curve Legend

CFM vs SP (1617)	—
100% EC (1800)	—
Min EC (500)	—
CFM vs Watts	—
Point of Operation	○
System Curve	- - - -

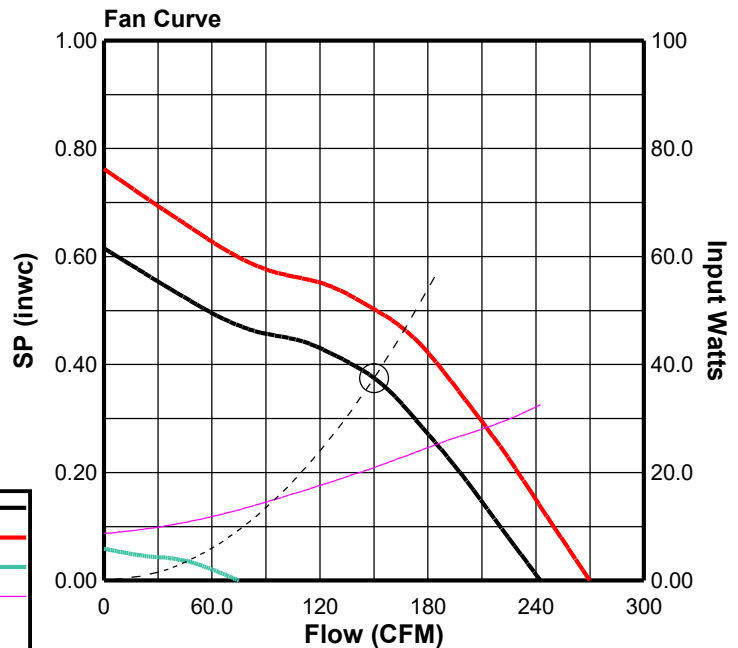



COOK



MARK: EF-4
PROJECT: URGENT VET - MATTHEWS
DATE: 1/18/2023

GEMINI Vari-Flow®

Inline Blowers 300, 500, 700 Series

STANDARD CONSTRUCTION FEATURES:
 Forward curved galvanized steel fan wheel -
 Corrosion resistant galvanized steel fan housing -
 Acoustically insulated housing - Aluminum backdraft damper with solid aluminum hinge rod mounted in nylon bushings - Permanently lubricated variable speed electronically commutated motor with built-in electronic overload protection and disconnect plug - Interchangeable panels with removable fasteners allows the intake to be easily changed - Internal wiring box with disconnect receptacle

E110

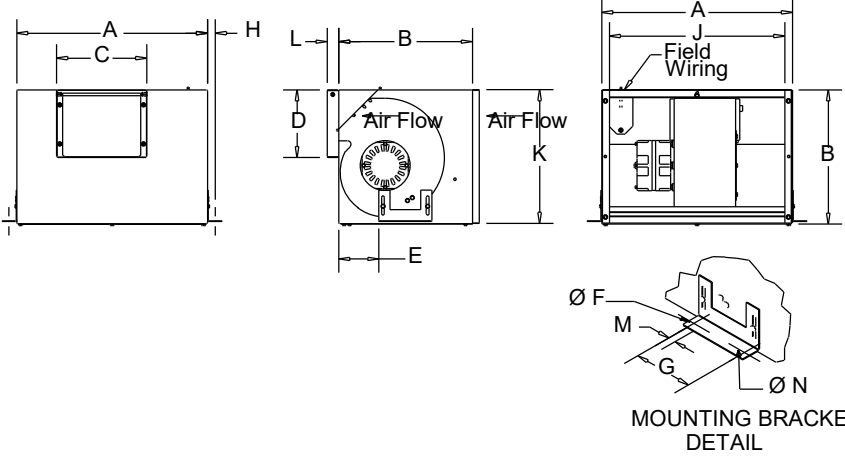

Performance

Qty	Catalog Number	Flow (CFM)	SP (inwc)	Nominal RPM	Input Watts	Speed Control
1	GNVF-340	150	.375	1617	21	EC

Altitude (ft): 768 Temperature (F): 70

Motor Information

Volts/Ph/Hz	Nameplate Amps
115/1/60	1.2



Motor is electronically/thermally protected.

Sound Data Inlet Sound Power by Octave Band

1	2	3	4	5	6	7	8	LwA	dBA	Sones
55	58	61	52	46	40	36	31	55	44	2.5

- Distance from Sound source 5 ft

Accessories:

- DISCONNECT NEMA 1
- CONTROL BY OTHERS
- EXT SPD CTRL CAPABLE
- GEMINI ISOLATOR KIT - ISOLATORS

Dimensions (inches)

A	12-3/8
B	10-7/8
C-Outlet	8
D-Outlet	6
L	1
E	3-9/16
F	1/2
G	4
H	13/16
J-Inlet	12-5/16
K-Inlet	10-11/16
M	1/2
N	3/16

NOTE: Accessories may affect dimensions shown.

Weight(lbs)***	Shipping 35	Unit 31
-----------------------	--------------------	----------------

***Includes fan, motor & accessories.

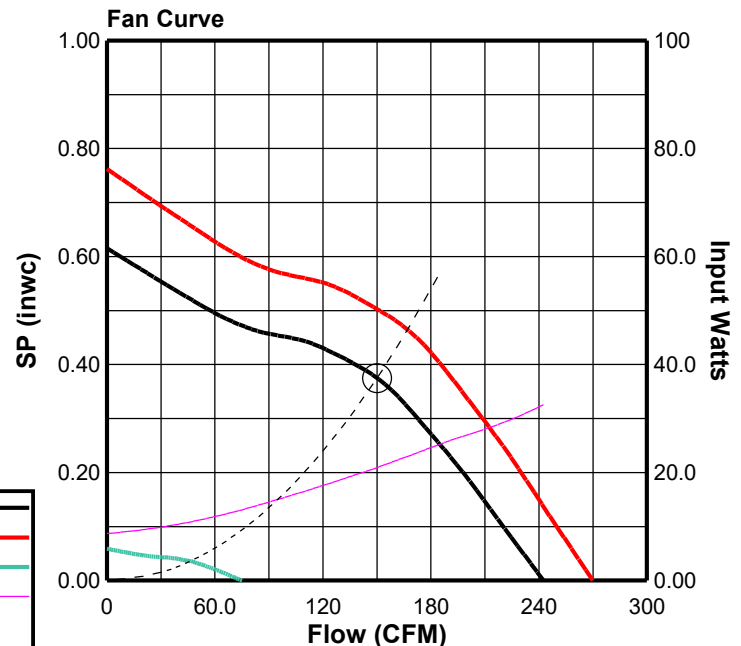

Fan Curve Legend

CFM vs SP (1617)	—
100% EC (1800)	—
Min EC (500)	—
CFM vs Watts	—
Point of Operation	○
System Curve	- - -



COOK

MARK: KEYED NOTE 4
PROJECT: URGENT VET - MATTHEWS
DATE: 1/18/2023

PR

Spun Aluminum Intake/Relief Ventilator

STANDARD CONSTRUCTION FEATURES:
All aluminum construction - Anti-backdraft flange - Five year warranty.

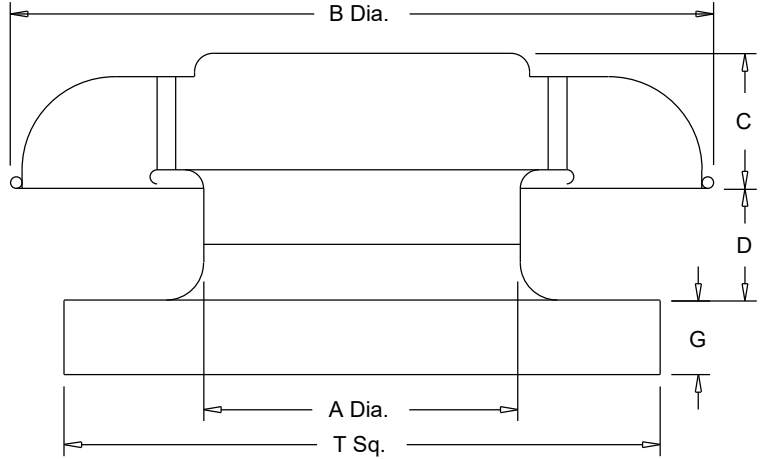

Performance

Qty	Catalog Number	Flow (CFM)	SP (inwc)
1	16 PR	778	.050

Altitude (ft): 768 Temperature (F): 70

Accessories:

ROOF CURB RCG 26 13.5H -C+T+N
BIRDSCREEN

Dimensions (inches)

A Dia.	16-1/2
B Dia.	27-3/4
C	5-1/16
D	5-1/2
G	2
T Sq.	28
Roof Open.	23-1/2

NOTE: Accessories may affect dimensions shown.

Weight(lbs)***	Shipping	68	Unit	62
-----------------------	-----------------	-----------	-------------	-----------

***Includes accessories.



Speed Control

External Signal Speed Control Electronically Commutated (EC) Motor Type P

STANDARD CONSTRUCTION FEATURES:

Integral potentiometer with slotted screw
for speed adjustment.

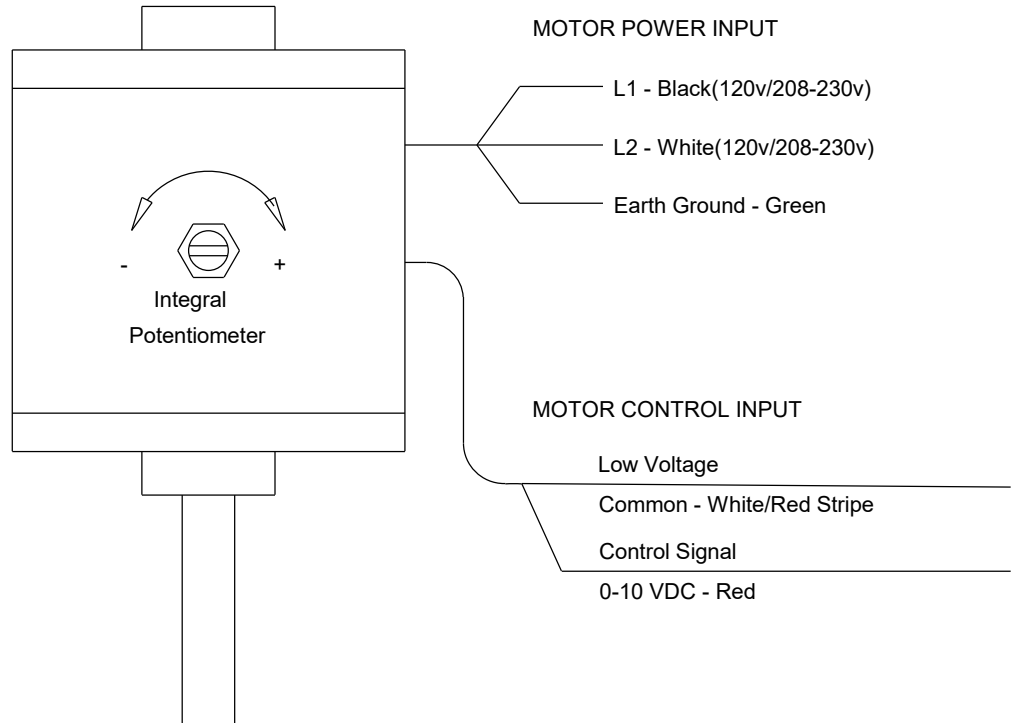

Dimensions (inches)

Mark	Qty	Description
EF-1	2	EXT SPD CTRL CAPABLE
EF-2	6	EXT SPD CTRL CAPABLE
EF-3	1	EXT SPD CTRL CAPABLE
EF-4	1	EXT SPD CTRL CAPABLE



COOK

PROJECT: URGENT VET - MATTHEWS

DATE: 1/18/2023

GEMINI

Gemini Isolator Kit
GIK
Rubber In Shear

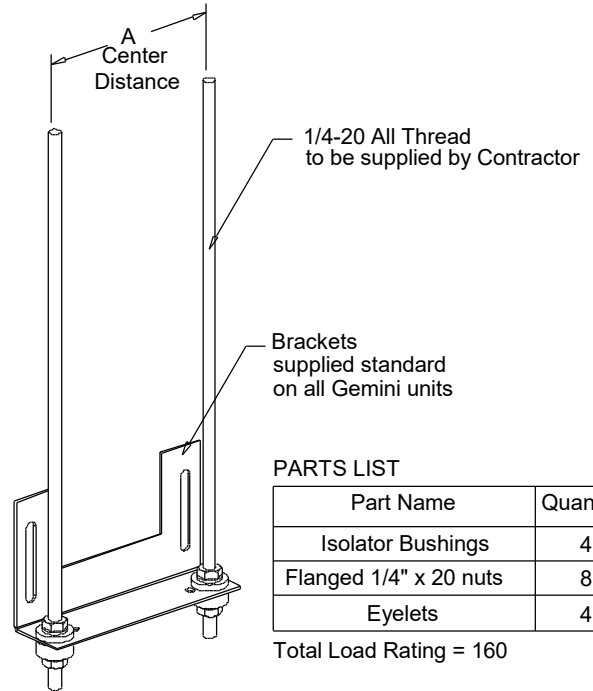

PARTS LIST

Part Name	Quantity
Isolator Bushings	4
Flanged 1/4" x 20 nuts	8
Eyelets	4

Total Load Rating = 160

Dimensions (inches)

Mark	Qty	Description	Part #	A
EF-1	2	GEMINI ISOLATO	GIK	4
EF-2	6	GEMINI ISOLATO	GIK	4
EF-3	1	GEMINI ISOLATO	GIK	4
EF-4	1	GEMINI ISOLATO	GIK	4



RCG

Galvanized Steel Roof Curb

STANDARD CONSTRUCTION FEATURES:

18 gauge galvanized steel - 1-1/2",
 3 lbs. density thermal and acoustical
 insulation - Continuously welded corners -
 Wood nailer.

Options:(As noted below*)

- 1) No wood nailer (deduct 1-1/2" for actual height).
- 2) Damper tray.
- 3) Liner.
- 4) Gasket on wood nailer.
- 5) Lorenized coating.
- 6) Enamel coating.
- 7) Burglar bars.

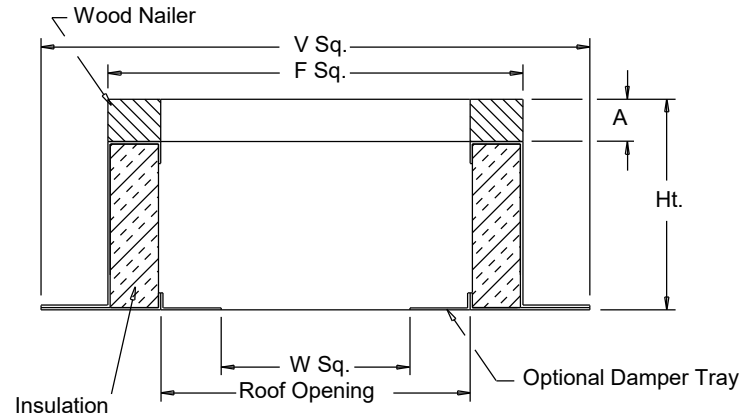

Dimensions (inches)

Mark	Qty	Description	Ht	Options*	A	F Sq.	V Sq.	W Sq.	Roof Opening
KEYED NOTE 4	1	RCG 26	13.5	2;	1-1/2	26-1/2	30-1/2	19-3/4	23-1/2