

SUBMITTAL DATA

REV # 0

PROJECT: Cincinnati State HPB Boiler Replacement
CONTRACTOR: Geiler Co.
PO / JOB # :
ENGINEER: CMTA – Cincinnati
DATE: 2/21/25

SUBMITTED BY: Eric Meyer
EMAIL: emeyer@b-g.com
PHONE: 513.489.5225
OPPORTUNITY # : 24-02160

SUBMITTED FOR:



APPROVAL

Submitted items will not be fabricated or delivered until approval is returned to Blackmore and Glunt confirming acceptance.



RECORD

Submitted items have either been ordered, are in the process of being fabricated, or have been delivered. Submitted for your records only. No action required.

Qty	Description & Tag
1	<p>Tag: P-1 PAGE 2 B&G Base Mounted Pump Series e-1510, Model 2EB, SS, 10 HP, 1800 RPM, 215T Frame, BG Choice, ODP, NEMA Premium Efficient w/SGR, Inverter Suitable, 230/460/3/60 Motor, 280 gpm, 93 ft – Includes Spare Seal</p>
1	B&G ED-3X Suction Diffuser Plus, 4" x 3" Flange
2	Metraflex MMCC-4 inch flanged stainless steel flex connector
1	<p>Tag: PB-2 PAGE 7 B&G ecocirc XL 45-375 Iron Body Circulator with 3HP ECM Type Motor with Built-In VFD, 400-460/3/60, 200 PGM, 25 FT TDH</p>
1	Metraflex LPD-4 inch flanged cast iron wye strainer
1	<p>Tag: AS-1 B&G SRS-4F Sediment Removal Separator., 4" Flange w/Air Vent and MBV-1 Blow Down Valve</p>
1	<p>Tag: ET-1 Wessels Co. NLA-1200 317 Gallon 125 PSI ASME Bladder Tank w/Air Vent</p>
1	<p>Tag: B-1 JJM Boiler Works NB-2 pH Neutralizer Kit for 2000 MBH Boiler</p>
1	<p>Tag: B-2 PAGE 17 Fulton EDR-2000 Gas Fired Condensing Boiler 2000 MBH Input Duplex SS alloy heat exchanger with PURE Technology including 15:1 Turndown, O2 Compensation, 4-28 inch W.C. CSD-1 Gas Train, Relief Valve, Low Water Cut Off, pH Neutralizer Kit 115/1/60</p>

Job/Project: Cincinnati State HPB Boiler Replacement		Representative: Blackmore and Glunt, Inc. - Cincinnati	
ESP-Systemwize: WIZE-390645F6	Created On: 02/21/2025	Phone: 513-489-5225	
Location/Tag: P-1		Email: emeyer@b-g.com	
Engineer: CMTA-Cincinnati	Submitted By: Eric Meyer	Date: 2/21/2025	
Contractor: Geiler Co.	Approved By:	Date:	

Base Mounted End Suction Pump

Series: e-1510

Model: 2EB

Features & Design

- ANSI/OSHA Coupling Guard
- Center Drop Out Spacer Coupling
- Fabricated Heavy Duty Baseplate
- Internally Self-Flushing Mechanical Seal

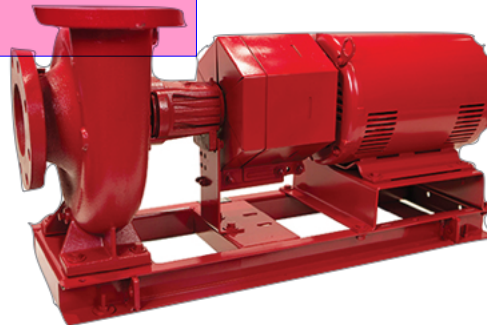

*The Bell & Gossett Series e-1510 is available in 26 sizes and a variety of configuration options that enable customization and flexibility to fit a broad range of operating conditions.

<http://bellgossett.com/pumps-circulators/end-suction-pumps/e-1510/>

Pump Selection Summary

Duty Point Flow	280.0 US gpm
Duty Point Head	93.0 ft
Control Head	27.9 ft
Duty Point Pump Efficiency	73.1 %
Part Load Efficiency Value (PLEV)	72.2 %
Impeller Diameter	10.625 in
Motor Power	10 hp
Duty Point Power	8.99 bhp
Motor Speed	1800 rpm
RPM @ Duty Point	1738 rpm
NPSHr	11 ft
Minimum Shutoff Head	120 ft
Minimum Flow at RPM	47 US gpm
Flow @ BEP	235 US gpm
Fluid Temperature	68 °F
Fluid Type	Water
Weight (approx. - consult rep for exact)	434 lbs
Pump Floor Space Calculation	5.53 ft ²

Performance Curve

Energy Efficiency Ratings:

Pump & Motor PEIcl: 0.86 ERcl: 14

Pump, Motor & Drive: PEIvl: 0.43 ERvl: 57



e-1510
2EB
1750 RPM

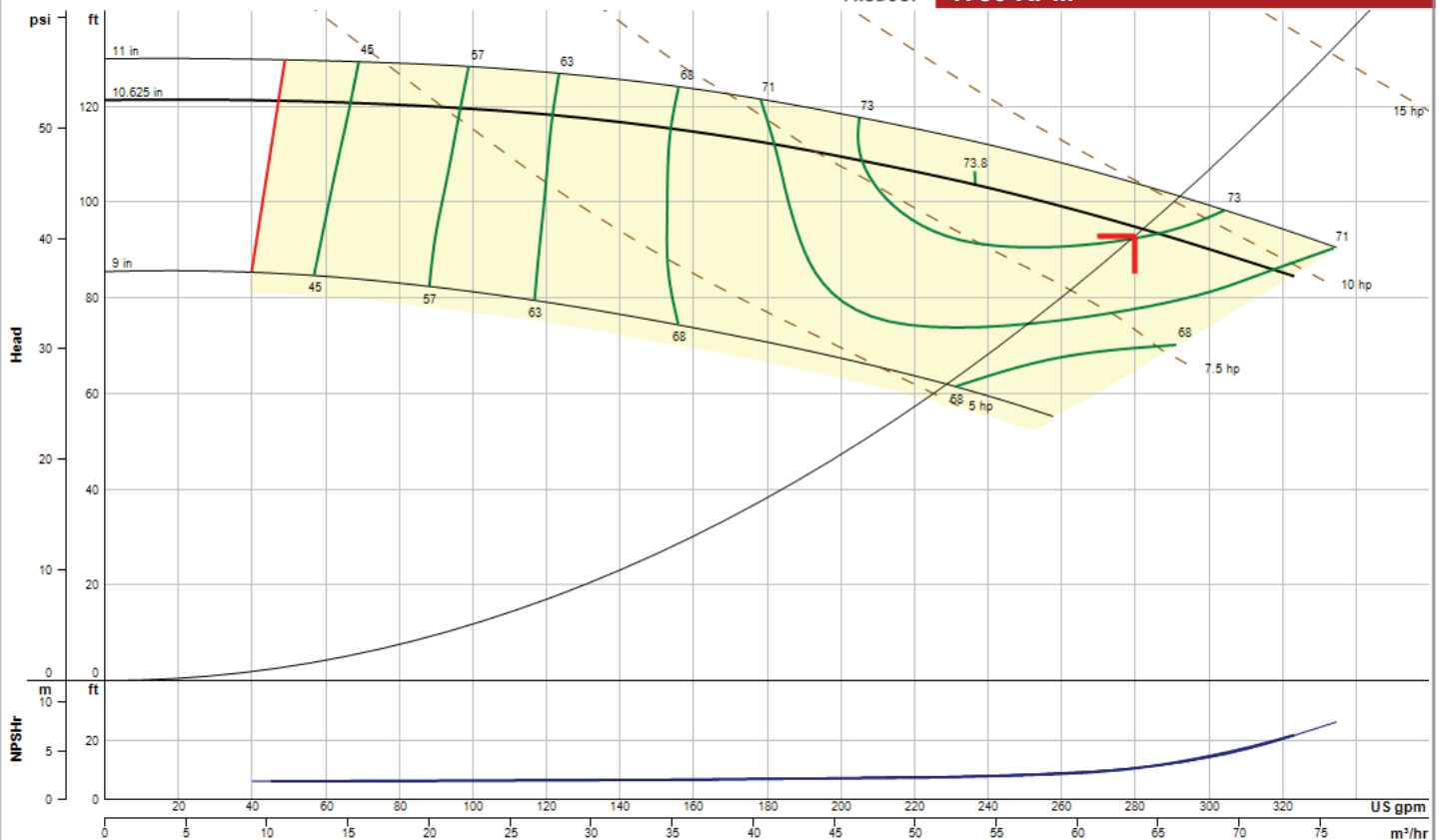

Performance curve meets 14.6 / ISO 9906 acceptance criteria

Materials Of Construction

Pump Information\Construction	
Pump Series	e1510
Pump Size	2 EB
Seal Type	Standard Seal
Seal Material	Buna/Carbon/Ceramic/SS/Bronze
Material of Construction	Stainless Steel Fitted
Impeller Diameter	10.625 inches
Sleeve Material	Stainless Steel Sleeve

Motor Details	
Motor Power	10
Motor Speed	1800
Frequency	60
Phase	3
Voltage	230/460
Frame	215T
Enclosure	ODP
Motor Manufacturer	BG Choice
Motor Status	MO
Motor Comments	NEMA Premium w/Shaft Grounding Rings

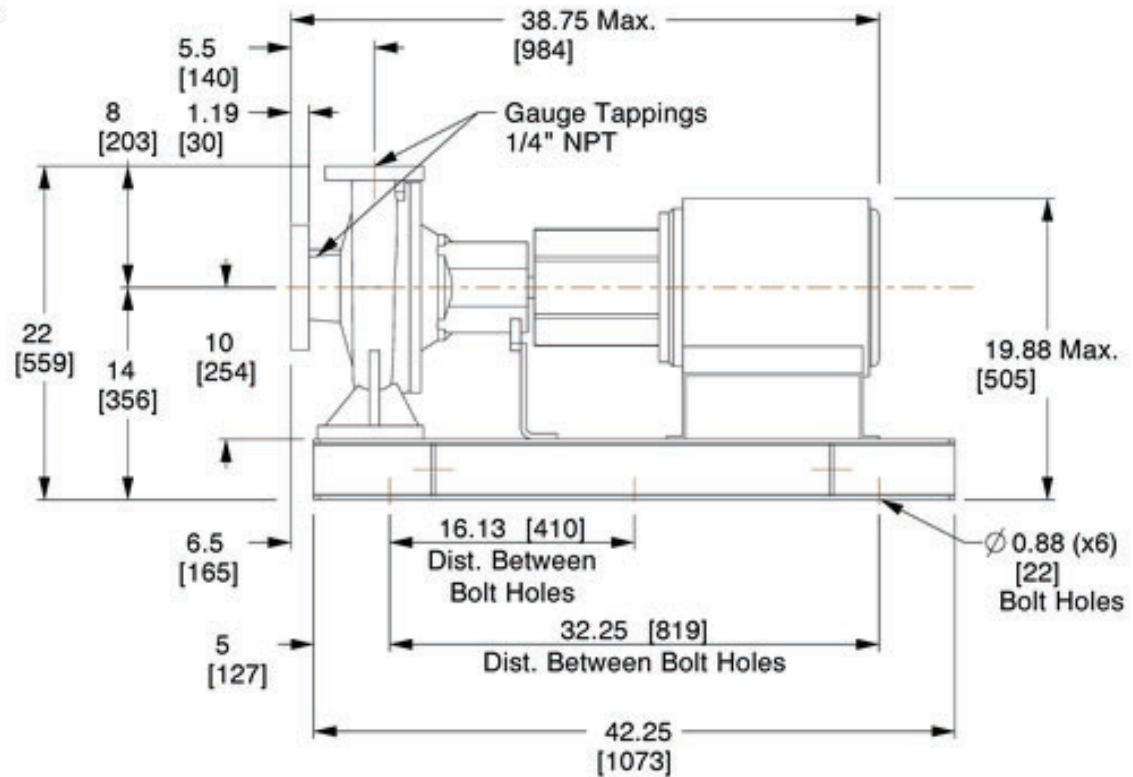
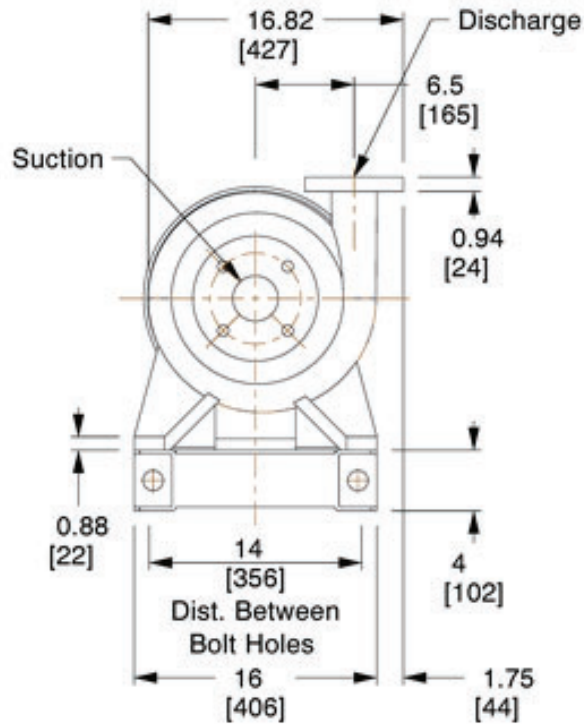
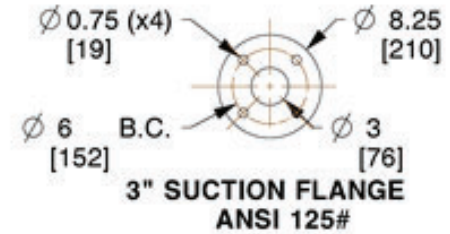
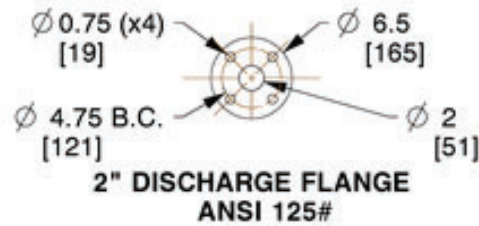
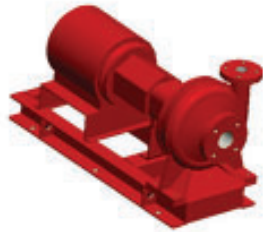

Bell & Gossett
a xylem brand

8200 N. Austin Ave.
Morton Grove, IL 60053, USA

This drawing and the information depicted therein is the property of Xylem. Copies are issued in strict confidence and shall not be reproduced or copied, or used as the basis for the manufacture or sale of products without prior written permission of Xylem.

Dimensions are subject to change
Not to be used for construction unless certified

BG-E1510-2EB-SS-215T-S

Series e-1510 Centrifugal Pumps - Base Mounted

Seal Type: Standard Seal | Motor Frame: 215T | Frame Type: S | Flange: ANSI 125#

Dimensions : IN (mm)

Scale : N.T.S.

Submittal # : B-880.30C

Standard Mechanical Configuration

Standard Mechanical Seal	SM, LG, & XL Bearing Frames	ES Bearing Frame
Temperature Range	-20 to 225°F	-20 to 225°F
Maximum Pressure	175 PSI	175 PSI
pH Limitations	7.0 - 9.0	7.0 - 9.0
Elastomer	Buna	Buna
Rotating Face	Carbon	Carbon
Stationary Face	Ceramic	Silicon Carbide
Hardware	Stainless Steel / Brass	Stainless Steel

Mechanical Seal Options	SM, LG, & XL Bearing Frames		
Temperature Range	-20 to 250°F	-10 to 225°F	-20 to 250°F
Maximum Pressure	175 PSI	175 PSI	175 PSI
pH Limitations	7.0 - 11.0	7.0 - 9.0	7.0 - 12.5.0
Elastomer	EPR (Ethylene Propylene Rubber)	FKM (Viton™ or Fluoroelastomer)	EPR (Ethylene Propylene Rubber)
Rotating Face	Carbon	Carbon	Silicon Carbide
Stationary Face	Tungsten Carbide	Ceramic	Silicon Carbide
Hardware	Stainless Steel / Brass	Stainless Steel	Stainless Steel

Mechanical Seal Options	ES Bearing Frame		
Temperature Range	-20 to 250°F	-10 to 225°F	-20 to 250°F
Maximum Pressure	175 PSI	175 PSI	175 PSI
pH Limitations	7.0 - 11.0	7.0 - 9.0	7.0 - 12.5.0
Elastomer	EPR (Ethylene Propylene Rubber)	FKM (Viton™ or Fluoroelastomer)	EPR (Ethylene Propylene Rubber)
Rotating Face	Silicon Carbide	Carbon	Silicon Carbide
Stationary Face	Tungsten Carbide	Silicon Carbide	Silicon Carbide
Hardware	Stainless Steel / Brass	Stainless Steel	Stainless Steel

Stuffing Box Configuration

Mechanical Seal	SM, LG, & XL Bearing Frames
Temperature Range	-20 to 250°F*
Maximum Pressure	175 PSI (Optional 250 PSI)
pH Limitations	7.0 - 11.0
Elastomer	EPR (Ethylene Propylene Rubber)
Rotating Face	Tungsten Carbide
Stationary Face	Carbon
Hardware	Stainless Steel

Packing Option	
Temperature Range	0 to 250°F
Maximum Pressure	175 PSI
pH Limitations	7.0 - 9.0
Material	Braided Graphite Impregnated PTFE

* For operating temperatures above 250°F a cooled flush is required and is recommended for temperatures above 225°F for optimum seal life. On closed systems cooling is accomplished by inserting a small heat exchanger in the flush line to cool the seal flushing fluid.

Flush-line Filters and Sediment Separators are available on special request.

Materials of Construction

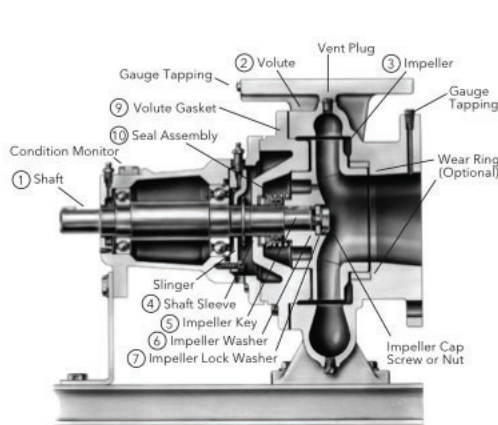

Standard Configuration

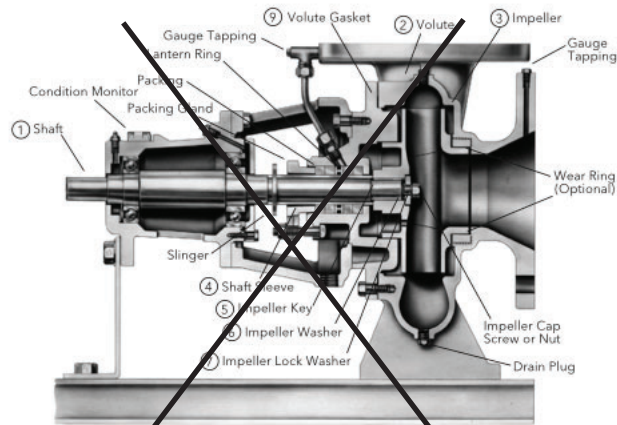

Optional - S Configuration

Description	SM, LG, & XL Bearing Frames	ES Bearing Frame
1 Shaft	ASTM 108 Grade 1144	ASTM 108 Grade 1144
2 Volute	Cast Iron ASTM A48 Class 30B	Cast Iron ASTM A48 Class 30B
3 Impeller	ASTM A743 Grade CF8 - 304 Stainless Steel	ASTM A743 Grade CF8 - 304 Stainless Steel
4 Shaft Sleeve	ASTM 312 Grade TP304 - 304 Stainless Steel	ASTM 312 Grade TP304 - 304 Stainless Steel
5 Impeller Key	#304 Stainless Steel	NA
6 Impeller Washer	Steel	NA
7 Impeller Lock Washer	#304 Stainless Steel (18-8 XL FRM)	NA
8 Impeller Cap Screw	#304 Stainless Steel	NA
8 Impeller Nut	NA	316 Stainless Steel
9 Volute Gasket	Cellulose Fiber	Cellulose Fiber
10 Seal Assembly	Reference Seal Data Tables	Reference Seal Data Tables

Pump Options

- Stainless Steel Volute Wear Ring
- Galvanized Steel Drip Pan
- Stainless Steel Shaft
- Rexnord Omega Spacer Coupling
- Falk T31 Spacer Coupling
- External Flush Line
- Stuffing Box Configuration
- Epoxy Coated Internal Cast Iron Components
- Special Impeller Balancing (ISO 1940 G2.5 or G1.0)
- Certified Performance Tests (Per HI Standard 14.6)
- 250 PSI Working Pressure

Job/Project: Cincinnati State HPB Boiler Replacement		Representative: Blackmore and Glunt, Inc. - Cincinnati	
ESP-Systemwize: WIZE-390645F6	02/21/2025	Phone:	
Location/Tag: P-1		Email:	
Engineer: CMTA-Cincinnati		Submitted By: Eric Meyer	Date: 2/21/2025
Contractor: Geiler Co.		Approved By:	Date:

Suction Diffuser Plus

Bell & Gossett Model: ED-3X

The Bell & Gossett Suction Diffuser Plus is designed for direct application to the pump suction and provides ideal flow conditions for the pump, providing NPSH requirements are met. Its integrated Flow Cone directs flow through the unit and into the pump suction while working with the full length straightening vanes to create a more uniform flow profile. The orifice cylinder has a free area equal to five times the cross section of the pump suction opening and serves as a coarse strainer to protect the pump from large sediment. Type X-For Closed Systems

<http://bellgossett.com/hydronic-plumbing-accessories/pump-accessories/suction-diffuser/>



Suction Diffuser Selection

Model	ED-3X
System Size	4.0 in
Pump Size	3.0 in
Pressure Drop @ Design Flow	0.0'
Connection Type	Flanged/Flanged
Cv	238
Fluid Type	Water
Fluid Temp	68 °F

Performance characteristics:

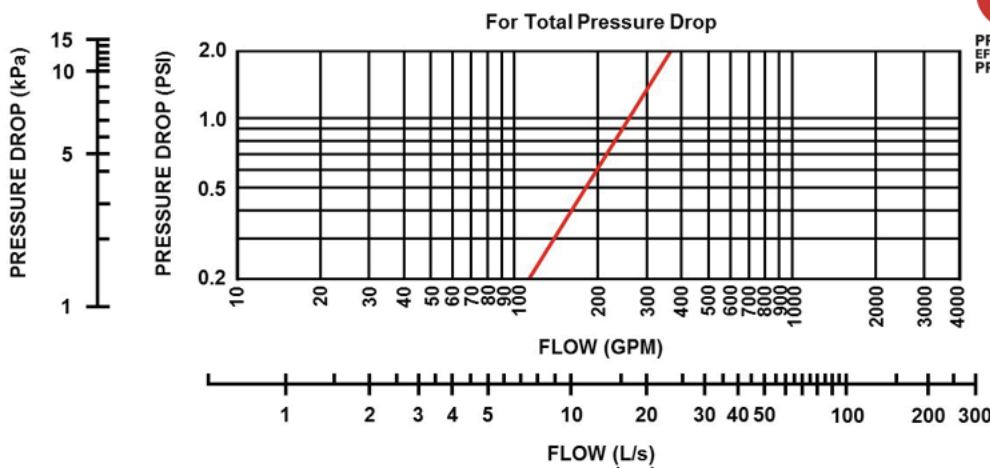

ED-3X

Materials of construction

Body	Cast Iron
Inlet Vanes	Steel
Orifice Cylinder	Steel
Start-up Strainer	16 Mesh Bronze

Operating Data

Max Working Pressure	175 psi
Max Temp	250°F

Dimensional data:

not for construction

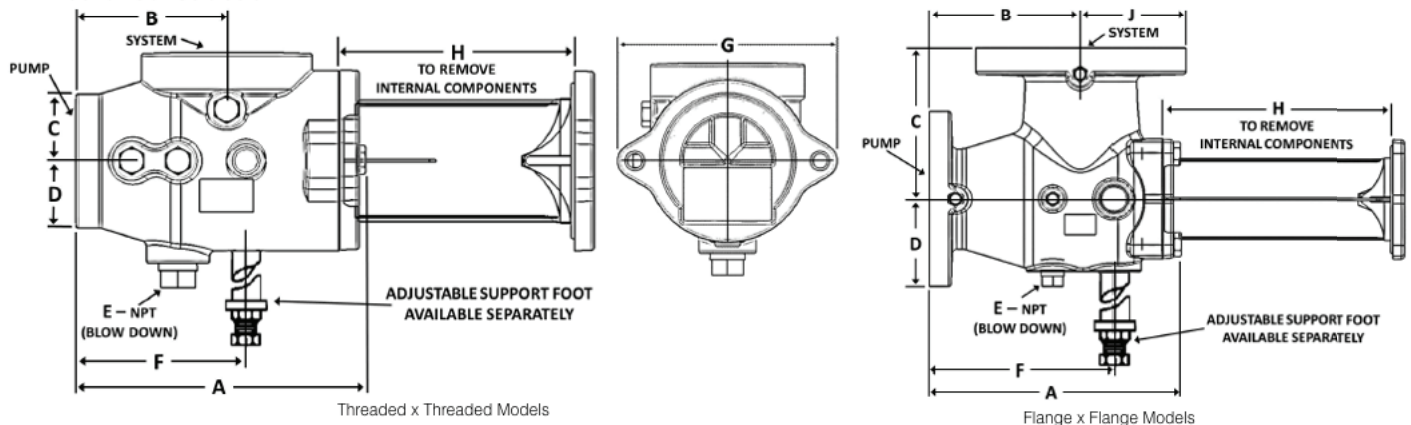

*Dimensions include orifice cylinder + 2-1/2 (64) inch clearance.

DIMENSIONS - INCHES (mm)

Model No.	System Side	Pump Side	A	B	C	D	E	F	G	H	J	Orifice Cylinder Free Area in ² (cm ²)	Approx. Shpg. Wt. Lbs. (Kg)
ED-3	4 (101.6)	F 3 (76.2)	11 (279.4)	6.50 (165)	6.50 (165)	3.75 (95)	3/4 (19)	7.93 (201)	N/A	10 (254)	4.5 (114)	37-1/2 (242)	55 (25)

Job/Project: Cincinnati State HPB Boiler Replacement	Representative: Blackmore and Glunt, Inc. - Cincinnati	
ESP-Systemwize: WIZE-390645F6	Created On: 02/21/2025	Phone: 513-489-5225
Location/Tag: PB-2	Email: emeyer@b-g.com	
Engineer: CMTA-Cincinnati	Submitted By: Eric Meyer	Date: 2/21/2025
Contractor: Geiler Co.	Approved By:	Date:

High Efficiency Large Wet Rotor Circulator with ECM Motor

Series: ecocirc® XL

Model: 45-375 3ph

The ecocirc® XL circulator is designed with a highly efficient electronically commutated permanent magnet motor (ECM/PM Technology). Cast Iron model designed for closed loop hydronic heating and cooling systems pumping water or water/glycol mix. Stainless Steel body pump designed for plumbing systems or open loop heating and cooling systems.



Selection Summary

Duty Point Flow	200.0 US gpm
Duty Point Head	25.0 ft
Control Head	0.0 ft
WTW Efficiency at Duty Point	63.6 %
WTW PLEV Efficiency	0.0 %
Motor Power	3.0
Electrical Input Power	1.99 hp
RPM @ Duty Point	2959 rpm
NPSHr	---
Minimum Shutoff Head	33.3 ft
Fluid Temperature	68 °F
Fluid Type	Water
Phase	3
Voltage	400-460
Weight (approx. - consult rep for exact)	50 lbs

Performance Curve



ecocirc XL
Ecocirc XL 45-375 3ph

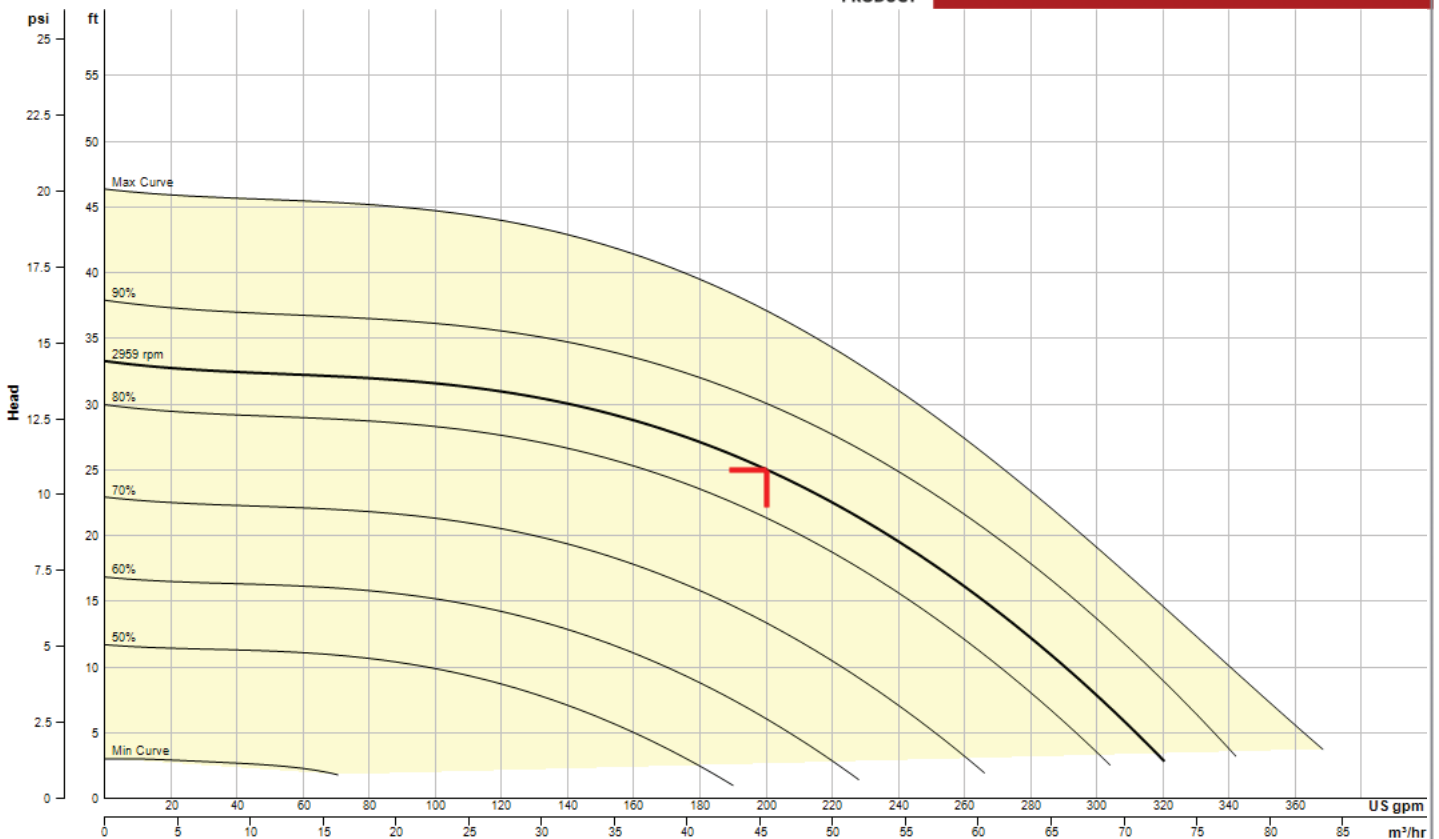

Performance curve meets 14.6 / ISO 9906 acceptance criteria

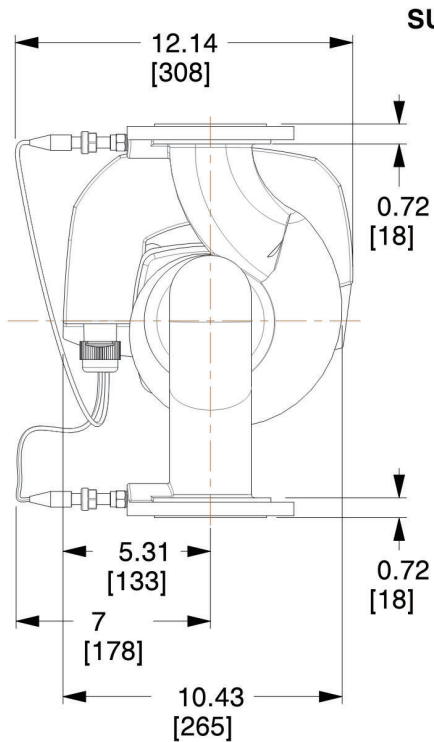
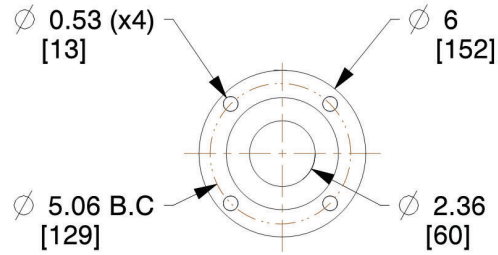

SUCTION & DISCHARGE FLANGE DETAILS

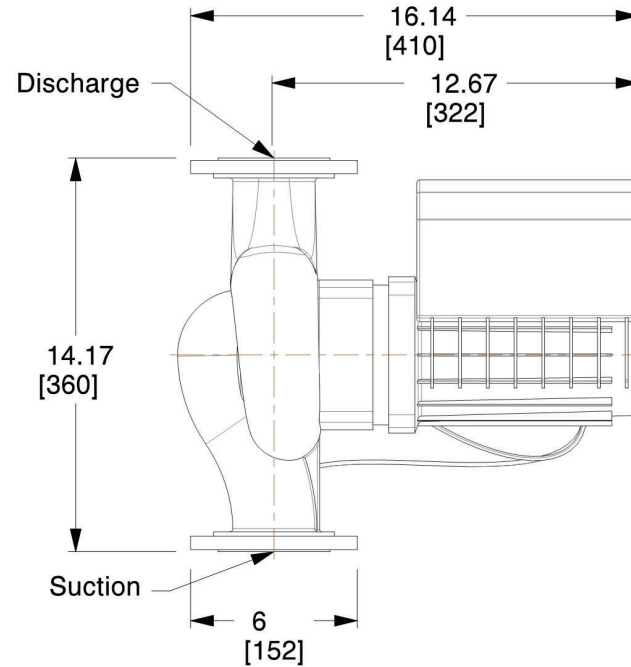

Bell & Gossett

a xylem brand

8200 N. Austin Ave.
Morton Grove, IL 60053, USA

This drawing and the information depicted therein is the property of Xylem. Copies are issued in strict confidence and shall not be reproduced or copied, or used as the basis for the manufacture or sale of products without prior written permission of Xylem.

Dimensions are subject to change
Not to be used for construction unless certified

BG-104328 ECOCIRC XL 45-375

Series ecocirc XL High Efficiency Large Wet Rotor Circulator with (ECM)

Motor Hp:3 | Voltage:400-460 | Phase:3 | Watts Range:120-2150 | Amp Range:0.6-4.0

Dimensions : IN (mm)

Scale : N.T.S.

Submittal # : A-429C

Standard Materials of Construction

Pump Body Construction:	Cast Iron or Stainless Steel
Impeller	Poly-phenylene Sulfide or Stainless Steel
Shaft	AISI 420 Stainless Steel
Rotor	Permanent Magnet
Bearing	Carbon Sleeve
Gasket/O-Ring	EPDM
All Other Wetted Parts	AISI 304 Stainless Steel
Motor Type	Electronically Commutated Motor/Permanent Magnet
Motor Insulation Class	F

Operating Data

Max Working Pressure	175 psi (12 bar)
Minimum Working Temperature	14°F (-10°C)
Maximum Working Temperature	230°F (110°C)
Ambient Temperature Range	32°F - 104°F (0°C - 40°C)



STANDARD OPERATING MODES

CONSTANT SPEED

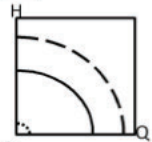

The pump maintains a constant speed at any flow rate. The desired speed is set on the interface panel of the pump.

CONSTANT PRESSURE ($\Delta p-c$)

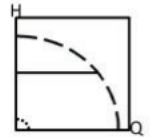

The pump maintains a constant differential pressure at any flow demand until the maximum speed is reached. The desired head of the pump can be set via user interface. Recommended for use in systems with small or constant pressure losses.

PROPORTIONAL PRESSURE ($\Delta p-v$)

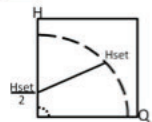

The differential pressure continuously increases or decreases based on the flow demand. The set point head can be set on the pump user interface. Use for systems with large pressure losses.

NIGHT MODE

The pump will automatically reduce speed when there is an abrupt change in fluid temperature. The change in fluid temperature is from a boiler operating in night time setback mode. The built-in temperature sensor is used. (Fixed Speed, Constant Pressure, Proportional Pressure)

TEMPERATURE DEPENDENT OPERATING MODES

SET POINT TEMPERATURE ($\Delta p-T$)

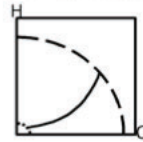

The nominal differential pressure set point is modified based on the fluid temperature. Uses the built-in temperature sensor.

SET POINT TEMPERATURE (T)

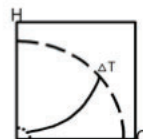

The pump maintains a constant temperature in a system, such as domestic hot water system or a single temperature heating system. Uses the built-in temperature sensor.

DIFFERENTIAL TEMPERATURE (ΔT)

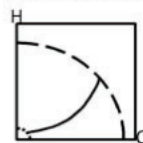

The pump maintains a constant differential temperature between the built-in and external temperature sensors.

INPUT SIGNALS

- One 0-10V (Analog): Speed Control by external controller
- One 4-20mA (Analog): Connection with an external differential pressure sensor for pressure control mode (two differential pressure sensor ranges: 0-15 and 0-30 PSIG) on single phase models.
- Two absolute pressure sensors 4-20mA (Analog) input for three phase models.
- One external temperature sensor input for Differential Temp operating mode. Sensor Type: KYT38, P/N: 104502
- One built-in temperature sensor for Set Point Temp and Differential-Temp operating mode.

REMOTE BUILDING MANAGEMENT SYSTEM CAPABILITIES

- The pump can be monitored or controlled by a signal from BMS (Building Management System). Built-in protocols are BACnet and Modbus. Direct connection to a PC is available.
- An optional wireless module can be added to create a short range wireless field for remote connection to the pump. An internet browser can be used to program the advanced settings. Module P/N: 104500

START/STOP CONNECTIONS: Connect to external dry contact relay or use with a thermostat.

OUTPUT RELAY(single phase): Normally Open Dry Contact Relay for Fault Mode indication.

OUTPUT RELAYS (three phase): Two Normally Open Dry Contact Relays for Fault Mode and Run indication.

ONBOARD USER INTERFACE

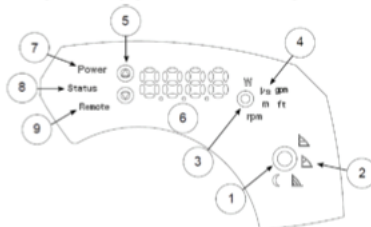

1. Control mode button
2. Control mode indicators
3. Parameter button
4. Parameter indicators
5. Setting buttons
6. Numeric display
7. Power indicator
8. Status / Fault indicator
9. Remote control indicator

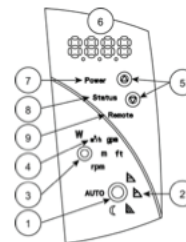

Job/Project: Cincinnati State HPB Boiler Replacement	Representative: Blackmore and Glunt, Inc. - Cincinnati		
ESP-Systemwize: WIZE-390645F6	02/21/2025	Phone:	
Location/Tag: AS-1	Email:		
Engineer: CMTA-Cincinnati	Submitted By: Eric Meyer	Date: 2/21/2025	
Contractor: Geiler Co.	Approved By:	Date:	

Sediment Removal Separators (SRS)

Bell & Gossett Model: SRS-4F

The Sediment Removal Separator is designed with tangential nozzles which create a centrifugal action within the separator that causes undissolved particles to be thrown against the inside diameter of the tank. It then falls to the bottom to be collected and either manually or automatically discharged from the tank. The centrifugal action also creates a low velocity vortex where air is separated and removed from the circulating water.



Separator Selection

Model	SRS 4F
Size	4.0 in
Recommended Max Flow	300.0 gpm
ASME Certified	true
Pressure Drop @ Design Flow	0.0'
Shipping Weight	129.0 lbs
Flooded Weight	237.0 lbs

Performance Coverage Chart:

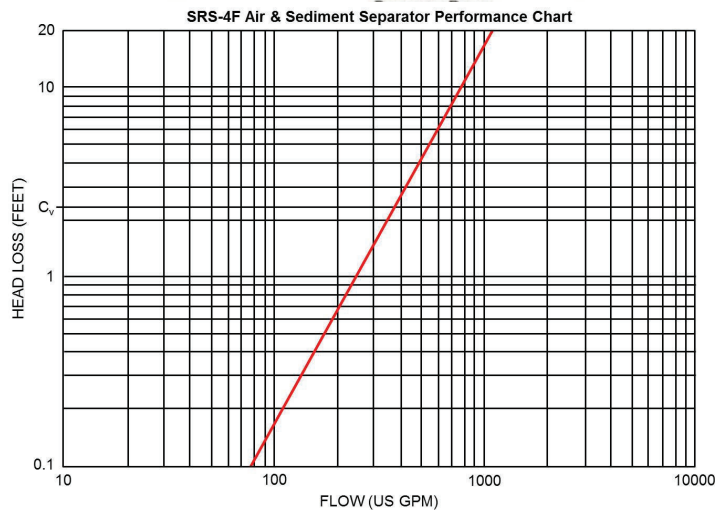

SRS 4F

Type of Separator	Centrifugal Air & Dirt Separator
-------------------	----------------------------------

Materials of Construction

Body	Carbon Steel
Air Collection Tube	304 SS

Operating Limits

Max Working Pressure	125.0 psig
Max Temperature	350.0 °F
Minimum Temperature	

Consult local rep for higher working pressures and temperatures.

Dimensional data:

1. A.S.M.E. constructed & stamped Sec. VIII Div 1 National Board Registration is required.
2. Max. allowable working pressure 125 psi (862 kPa) at 350 °F (177 °C)

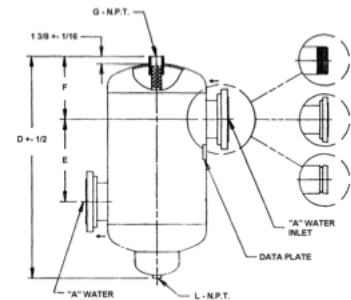
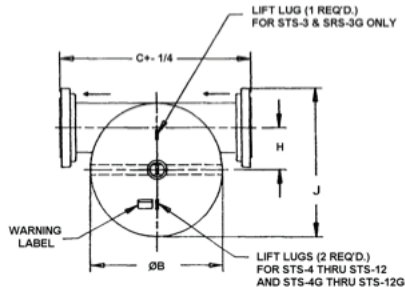

DIMENSIONS - INCHES (MM)

CAT. NO.	SIZE OF TANGENTIAL OPENINGS	B (MM)	C (MM)	D (MM)	E (MM)	F (MM)	G	H (MM)	J (MM)	L	APPROX. SHPG. WT. LBS. (Kg)
SRS 4F	4" Flanged	12-3/4 (324)	20-1/2 (521)	31-1/8 (791)	10 (254)	9-1/2 (241)	1-1/2 (38)	4-1/8 (105)	15 (381)	1 (25)	105 (48)

Dimensions are subject to change. Not to be used for construction purposes unless certified.
 SRS-3F includes welded flanges, not companion flanges.

JOB: Cincinnati State HPB Boiler Replacement

REPRESENTATIVE: Blackmore and Glunt - Cincinnati

UNIT TAG:

ORDER NO.

DATE: 2/21/2025

ENGINEER: CMTA-Cincinnati

SUBMITTED BY: Eric Meyer

DATE:

CONTRACTOR: Geiler Co.

APPROVED BY:

DATE:



Miscellaneous Accessories

DESCRIPTION

NO. 87, 67, and 7 AUTOMATIC AIR VENTS - are designed to vent the accumulation of troublesome air wherever it can be trapped. These non-ferrous automatic air vents are 4-3/4"x2-1/4", 3-3/16"x1-1/2", and 4-1/6"x2-3/16"(height and width), respectively, and are rated for a maximum operating temperature of 240°F at pressures of 150, 35, and 75 PSI, respectively. The No. 87 has a combination of 1/2" FPT / 3/4"MPT connection, whereas No's. 67 and 7 have 1/8" MPT and 1/8" FPT connections, respectively.

No. 26 VACUUM BREAKER - Designed to protect closed vessels and piping systems against collapse when the induced vacuum exceeds design conditions. When used on steam heating piping systems, the No. 26 Vacuum Breaker controls induced vacuum permitting normal return of condensate to the boiler. Adjustable range 1/4" to 20" (mercury) vacuum - 150 PSIG maximum working pressure - 240 °F maximum operating temperature (Factory set at 4" mercury).

No. 17 SR. AUTOMATIC AIR VALVE - No. 17 Sr. Valve is a deluxe, hygroscopic air valve with manual shut-off. 1/8" MNPT connection.

30 PSIG Working Pressure
225 °F Maximum Operating Temperature

No. 4V "COIN-OPERATED" AIR VENT - This vent is specially designed for the new types of radiators. A particular feature is that it projects only slightly, being almost flush with the radiator.

150 PSIG Working Pressure
250 °F Maximum Operating Temperature

NO. 107A HIGH CAPACITY AIR VENT - A rugged High Capacity Air Vent designed to purge free air from liquid systems at operating pressures up to 150 psig. The Model 107A Air Vent has a cast iron body and bonnet, with stainless steel, brass, and EPDM internal components and is suitable for a maximum operating temperature of 250°F. The Model 107A Air Vent has a 3/4" FNPT inlet and 3/8" FNPT outlet.

RV-125A READOUT VALVE AND RP-250B READOUT PROBE - The RV-125A is designed for use wherever pressure tapings are required to monitor flow or pressures. This Readout Valve is fitted with an EPT insert which incorporates a unique check valve feature designed to check flow when the Readout Valve is not being used to monitor flow. Use companion RP-250B Readout Probes with the RV-125A Readout Valve. 300 PSIG working pressure - 250°F maximum operating temperature.

DT-2 DRAIN-O-TANK® AIR CHARGER - The Drain-O-Tank Air Charger offers a sure, quick way to recharge a water-logged compression tank.

125 PSIG Working Pressure
240 °F Maximum Operating Temperature



No. 97 Air Vent - is a float type automatic air vent that is designed to vent troublesome air from hydronic heating systems. The 97 vent has forged brass body and cap with non-ferrous internals. The vent is 3-1/8"x1-7/8" with a maximum operating pressure of 150 PSI and temperature of 240°F.

150 PSIG Working Pressure
240 °F Maximum Operating Temperature



No. 98 Air Vent - is a high capacity automatic air vent that is designed to remove air in closed loop systems. The No. 98 high capacity air vent has brass body and cap with non-ferrous internals. The vent is 4-1/2"x2-1/4" with with 1/2" NPTF connection.

150 PSIG Working Pressure
250 °F Maximum Operating Temperature

SCHEDULE

MODEL NUMBER	PART NUMBER	PRODUCT	MAXIMUM WORKING PRESSURE PSIG	MAXIMUM OPERATING TEMPERATURE °F	TAGGING INFORMATION	QUANTITY
4V	113055	Air Vent	150	250		
67	113020	Automatic Air Vent	35	240		
7	113001	Automatic Air Vent	75	240		
 87	113021	Automatic Air Vent	150	240	ET-1	1
 107A	113076	High Capacity Automatic Air Vent	150	250	AS-1	1
17 Sr.	113004	Automatic Air Valve	30	225		
26	113075	Vacuum Breaker	150	250		
DT-2	113041	Drain-O-Tank	125	240		
97	113222	Automatic Air Vent	150	240		
98	113246	High Capacity Automatic Air Vent	150	250		
RV-125A	113100	Readout Valve	300	250		
RP-250B	113102	Readout Probe	300	250		

DIMENSIONS AND WEIGHTS

MODEL NUMBER	PART NUMBER	DIMENSIONS INCHES		CONNECTIONS INCHES NPT		APPROX. SHPG. WT. LBS.	
		WIDTH	HEIGHT	SIZE	TYPE	CARTON OF	TOTAL
4V	113055	5/8	5/8	1/8	M	48	2.0
67	113020	1-1/2	3-3/16	1/8	M	12	3.0
7	113001	2-3/16	4-1/16	1/8	F	12	6.0
 87	113021	2-1/4	4-3/4	3/4 1/2	M F	12	8.0
 107A	113076	4-1/2	9-5/8	3/4	F	1	10.0
17 Sr.	113004	13/16	1-1/4	1/8	M	12	2.0
26	113075	1-1/4	3	3/4	M	6	3.0
DT-2	113041	2-1/4	9-5/16	1/2	M	12	8.0
97	113222	1-7/8	3-1/8	1/8	M	10	4.0
98	113246	2-1/4	4-1/2	1/2	F	10	8.0
RV-125A	113100	1/2	1-3/32	1/8	M	50	4.0
RP-250A	113102	1/2	1-31/32	7/16	M	6	0.1

* All dimensions and weights are approximate and not to be used for construction, pre-piping or freight rating unless certified by Bell & Gossett in writing.

MATERIALS OF CONSTRUCTION

Body (all products except Model 107A High Capacity Air Vent): Brass

Body & Bonnet (Model 107A High Capacity Air Vent): Cast Iron

Internals: Nonferrous

JOB: Cincinnati State HPB Boiler Replacement

REPRESENTATIVE: Blackmore and Glunt - Cincinnati

UNIT TAG:
ENGINEER: CMTA-Cincinnati
CONTRACTOR: Geiler Co.

ORDER NO.
SUBMITTED BY: Eric Meyer
APPROVED BY:

DATE: 2/21/2025
DATE:
DATE:

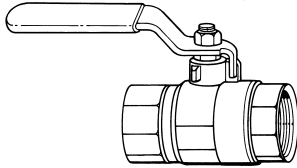

Rolairtrol/SRS Manual Blowdown Valve

The model MBV is a manual blowdown valve which can be added to the blowdown connection of any B & G Rolairtrol air separator or SRS sediment removal separator. The function of the MBV is to facilitate the manual purging of sediment from the vessel. The MBV-1 has a full port with a 1" NPTF connection. The MBV-2 has a full port with a 2" NPTM connection. The MBV-3L and MBV-3H have a full port with a 3" NPTM connection. The MBV-3L is rated for 125 psi maximum working pressure, while the MBV-3H is rated for 290 psi maximum working pressure.

TYPICAL SPECIFICATIONS

Furnish and install as shows on plans ITT Bell & Gossett Manual Blowdown Valve Model MBV-____. A manual blowdown valve used for purging sediment from a hot or chilled water shall be a ____ size with NPT male/female connections. The valve shall have a brass or bronze body, a reinforced TFE seat, and in the case of 3" models, shall include a 3" x 2" reducer made of either cast iron or forged steel. Manual blowdown valve shall be suitable for use up to ____ PSIG (____ kPa) working pressure at 250°F (121°C).

OPERATIONAL LIMITS

Maximum Working Pressure: 125 PSIG (862 kPa) or 290 PSIG (2,000 kPa)*
Maximum Operating Temperature: 250 °F (121 °C)

*125 PSIG maximum working pressure applies to model MBV-3L blowdown valve. 290 PSIG maximum working pressure applies to MBV-1, MBV-2, and MBV-3H blowdown valve.

CONSTRUCTION

Ball Valve
Body: Brass
Ball: Chrome Plated Brass
Seal: Reinforced PTFE
Packing: PTFE

Reducer Bushing

Low Pressure Reducer: Cast Iron
High Pressure Reducer: Forged Steel

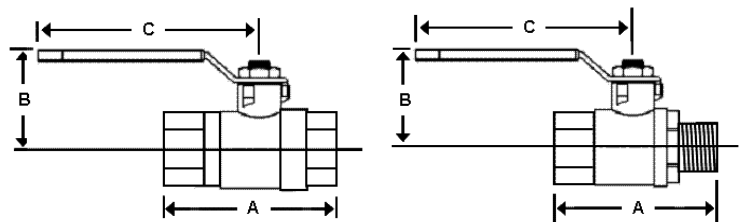

MBV-1

MBV-2

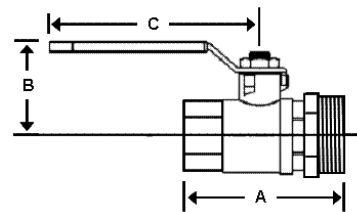

MBV-3L and MBV-3H

MOTOR FRAME	DIMENSIONS** - INCHES (mm)			Approx. Wt. lbs. (kg)
	A	B	C	
MBV-1	3.2 (81.3)	2.3 (58.4)	4.6 (116.8)	1.5 (0.7)
MBV-2	7.7 (195.3)	3.7 (93.5)	6.6 (166.9)	5.0 (2.3)
MBV-3L	8.5 (216.0)	3.7 (93.5)	6.6 (166.9)	6.5 (2.9)
MBV-3H	8.5 (216.0)	3.7 (93.5)	6.6 (166.9)	6.5 (2.9)

****Dimensions are subject to change. Not to be used for construction purposes unless certified.**

SCHEDULE

PART NUMBER	MODEL	SIZE	TAGGING	QUANTITY
5358-001-00-002	MBV-1	1"	AS-1	1
5358-002-00-001	MBV-2	2"		
5358-002-00-002	MBV-3L	3"		
5358-002-00-003	MBV-3H	3"		



SINCE 1908
wessels
 company

SUBMITTAL

NLA-SERIES
 HVAC EXPANSION TANKS

Models: NLA-1000 to NLA-15000

Submittal Sheet No. A-1011B Rev. 5 7/18/2019

Job Name	Cincinnati State HPB Boiler Replacement	Submitted By	Eric Meyer	Date	2/21/2025
Location	Cincinnati, OH	Approved By		Date	
Engineer	CMTA - Cincinnati	Order No.		Date	
Contractor	Geiler Co.	Notes			
Sales Rep.	Blackmore and Glunt, Inc. - Cincinnati				

Description:

Wessels patented NLA Tanks are ASME removable bladder type pre-charged HVAC expansion tanks. They are designed to absorb the expansion forces and control the pressure in heating/cooling systems. The system's expanded water (fully compatible with water/glycol mixtures) is contained in a full acceptance heavy-duty butyl bladder that prevents tank corrosion and waterlogging problems. All NLA expansion tanks can be installed vertically or horizontally.

Construction:

Shell: Carbon Steel
 Heads: Carbon Steel
 Exterior: Carbocoat 140 - Harvester Red
 Interior: Heavy Duty Butyl Bladder

Design Parameters:

Maximum Design Pressure: 125 PSIG*
 Temperature Range: -20°F to 240°F

*150 PSIG and up are available

Model Number	Part Number	Tank Volume (Gallons)	Tagging Information	Quantity
NLA-1000	22011000	264		
→ NLA-1200	22011200	317	ET-1	1
NLA-1400	22011400	370		
NLA-1600	22011600	422		
NLA-2000	22012000	528		
NLA-2500	22012500	660		
NLA-3000L	22013000	792		
NLA-3000S	22013001	792		
NLA-4000	22014000	1056		
NLA-5000	22015000	1320		
NLA-7500	22017500	1980		
NLA-10000	22019999	2640		
NLA-15000	22019998	3963		

Typical Specification

Furnish and install, as shown on plans, a _____ gallon _____" diameter X _____" (high) pre-charged steel HVAC expansion tank with heavy-duty butyl bladder. The tank shall have an NPT water side system connection, a 0.302"-32 charging valve connection (standard fire valve) to facilitate the on-site charging of the tank to meet system requirements, a pressure gauge, and bladder integrity monitor. The tank must be constructed in accordance with the most recent addendum of Section VIII Division 1 of the ASME Boiler and Pressure Vessel Code and rated for 125 psig.

Each tank shall be Wessels model number NLA-_____ or approved equal.

E-mail



SINCE 1908
wessels
 company

101 Tank Street Greenwood, IN 46143
 P: 317-888-9800 F: 317-865-7411
 www.westank.com



SINCE 1908
wessels
 company

SUBMITTAL

NLA-SERIES
 HVAC EXPANSION TANKS

Models: NLA-1000 to NLA-15000

Submittal Sheet No. A-1011B Rev. 5 7/18/2019

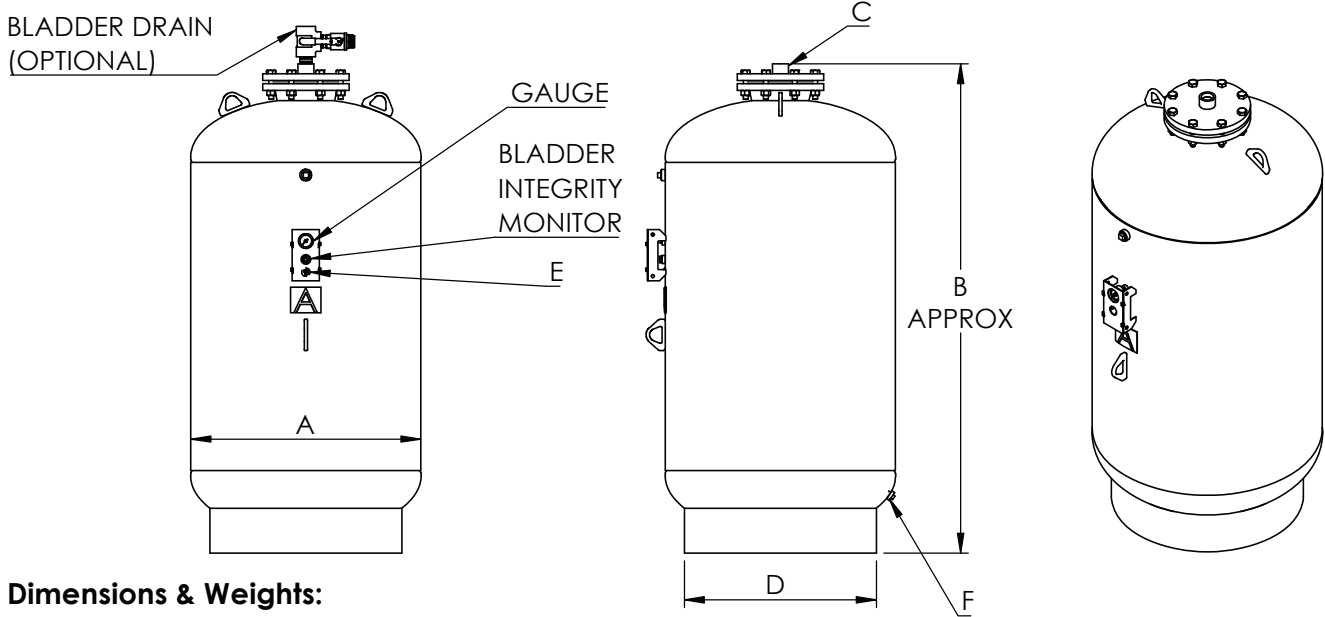

Dimensions & Weights:

Model Number	Dimensions in Inches						Approx. Shipping Weight (lbs)
	A	B	System Connection	D	Charging Valve	Plug	
			C		E	F	
NLA-1000	36	76	1 1/2 NPT	30	0.302"-32NC	3/4 NPT	552
NLA-1200		88					679
NLA-1400		100					688
NLA-1600	48	74	42	1046			
NLA-2000		86		1150			
NLA-2500		104		1444			
NLA-3000L	60	124	2 NPT	54		1658	
NLA-3000S		83				1868	
NLA-4000		105				2238	
NLA-5000	72	128	3 NPT	66		1 NPT	2617
NLA-7500		131					3768
NLA-10000		162					4628
NLA-15000		233				5925	

Notes:

- Tanks are factory pre-charged at 40 psig and field adjustable.
- California code-sight glass is available upon request.
- Mounting clips are available upon request.
- Bladder drain is available upon request.
- Tanks installed horizontally must have the system connection below the horizontal centerline of the tank.
- Plug (F) is on the air side of the tank. Do not remove.
- U.S. Patent No. 8,633,825 B2.



SINCE 1908
wessels
 company

101 Tank Street Greenwood, IN 46143
 P: 317-888-9800 F: 317-865-7411
 www.westank.com



BILL OF MATERIALS

Date: February 21, 2025
Project: Cincinnati State HPB Boiler Replacement
Engineer: CMTA – Cincinnati
Contractor: Geiler Co.
Representative: Blackmore & Glunt, Inc.
Tag: B-2

DETAILS

DOCUMENT

Gas Fired Endura Boiler – EDR-2000	
Supplemental Technical Data	Tech Data Sheet
Boiler Drawing	7-91-082000-PDS_B
Thermal Efficiency Curve	effcurve
ARHI Certified to BTS-2000	AHRI
Water Side Pressure Drop Curve	pressuredrop
Gas Train for Natural Gas Burner @ 4-28" W.C.	
Wiring Diagram for 115/1/60 Power Supply	7-53-081500_A
Header Temperature Sensor*	PT100-Header_TDS
Condensate Trap*	Condensate Trap
Condensate Neutralizer Kit*	NB-2
BACnet Communications Gateway*	
*Items Shipped Loose for Field Installation by Others	

BOILER DESCRIPTION

Fully Condensing Ultra-High Efficient Duplex Stainless Steel Firetube Heat Exchanger
ASME Section IV with H Stamp for 160 PSI Maximum Working Pressure
Factory Assembled CSD-1 Controls & Fuel Train and complies with AXA XL and FM
PURE Control with Fully Modulating Burner and Precision Flame-by-Wire Control for
Natural Gas using Direct Spark Ignition System
O₂ Compensation to continuously adjust the boiler air-fuel ratio in real time
Color Touch Screen User Interface, 7"
Integrated Lead/Lag for 2-10 Boilers
Modbus Communication Protocol
Operating and High Limit Aquastats
Low Water Cut Off Probe with Manual Reset
Low and High Gas Pressure Switches
Air and Blocked Flue Switches
Combustion Air Filter
Control Circuit Transformer
Additional Items Shipped Loose for Field Installation by Others
 Pressure Relief Valve Set At – **PLEASE ADVISE SETTING**
 Pressure/Temperature Gage
 CPVC Flue Gas Exhaust Kit

Warranty

Warranty Statement

ENDURA (EDR) SERIES:

EDR-750, EDR-1000, EDR-1500, EDR-2000

750,000 to 2,000,000 BTU/HR:

Duplex Stainless Steel Firetube Condensing Boilers



Fulton's Endura (EDR) line of condensing boilers are a durable three-pass firetube derived from a rugged pressure vessel architecture with over thirty years of proven performance. The packaged boiler features an ultra-compact footprint that fits through a standard doorway, reliable quiet operation, access panels which detach in seconds, and simplified service & maintenance. The highly-engineered robust construction is built to last with thicker, higher-strength materials, and a premium fit and finish reflecting Fulton's paramount quality. The high-turn-down combustion technology utilizes the surgical precision of independent air and gas servo motors and continuously tunes the air/fuel ratio for ideal excess O₂ levels to automatically adjust for seasonality. This maximizes condensing potential, and outperforms all conventional platforms in durability, reliability and repeatability.

STANDARD FEATURES:

- Factory Packaged and Test Fired Boiler Assembly
- Duplex Stainless Steel Firetube Heat Exchanger
- Fully Condensing Ultra-High Efficiency Operation
- Designed for Variable Primary Flow Arrangements
- Fully Modulating Burner; Up to 15:1 Turndown
- Low NOx Emissions <20 ppm
- Flame-by-Wire™ Combustion Control; ± 0.2° Precision
- Real-Time O₂ Compensation™; Feed Forward
- Variable Speed Combustion Blower
- Direct Spark Ignition System
- 160 PSIG Maximum Allowable Working Pressure
- 210°F Maximum Allowable Working Temperature
- Factory Recommended Maximum Setpoint 190°F
- Operating and High Limit Aquastats; 200°F Setting
- Low Water Cut Off Probe with Manual Reset
- 50 Micron Combustion Air Intake Filter
- Air and Blocked Flue Switches
- Ventless Gas Train
- Low and High Gas Pressure Switches
- Emergency Stop (E-Stop) Contact

PURE CONTROL™ CAPABILITIES: v1.0.0.0+

- 7-inch Color Touchscreen Display
- Integrated Lead-Lag of 2 to 10 Boilers
- Universal Data over Ethernet/IP; No Master Boiler Req.
- Modbus Communication Protocol
- Flue Gas Exhaust Temperature Monitoring
- Inlet and Outlet Water Temperature Sensors
- Combustion Air Temperature Sensor
- Outdoor Air Temperature Reset with Plant Cutoff
- Trending Data Logging
- Setback Modes via Internal Clock
- Accept 4-20mA or 0-10VDC Remote Setpoint Signal
- Two Safety Interlock Contacts for External Device(s)
- Monitoring Contacts (Status, Demand, Alarm)
- Remote Boiler Enable Contact
- Motorized Isolation Valve Control
- Variable Speed Secondary Pump Control (2 Pumps)
- Automatic Rotation of Secondary Pumps
- Variable Speed Primary Pump Control
- Domestic Hot Water Priority with DHW Pump Start/Stop
- Two-Stage Freeze Protection

PROJECT DETAILS:

Project Name	Cincinnati State HPB Boiler
Date Submitted	2/21/2025
Fulton Representative	Blackmore and Glunt, Inc.

City, State (Province)	Cincinnati, OH
Engineer of Record	CMTA - Cincinnati
Contractor	Geiler Co.

LISTINGS & COMPLIANCE:

- ASME Section IV, "H" Stamp
- ETL Listed to UL-795
- CSD-1 and CSA Controls and Fuel Train
- AXA XL Compliant; Supersedes IRI
- AHRI Certified to BTS-2000
- FM Compliant Fuel Train Components
- SCAQMD Certified; TCEQ Compliant

TRIM KIT ITEMS:

- ASME Safety Relief Valve 60, 100, 125, or 160 PSIG
- Pressure & Temperature Gauge
- Installation, Operation and Maintenance Manual

OPTIONAL ACCESSORIES: PARTS SHIP LOOSE FOR FIELD INSTALLATION

- BACnet Protonode with Remote Cloud Access 2-45-001058-30
- Lead/Lag IP Switch (8 Port, 120VAC) 2-45-315010
- Lead/Lag IP Switch (5 Port, DIN Mount, 24VDC) 2-45-315044-31
- Second (Auxiliary) Low Water Cut Off Kit 4-30-000330
- Multiple Boiler Condensate Drain Trap (12MM Max) 4-57-000440
- Individual Boiler Condensate Drain Trap (4MM Max) 4-57-005500
- pH Neutralization Kit (12MM Max) 4-50-000008
- PVC/CPVC Flue Gas Exhaust Kit for EDR-750/1000/1500 4-50-071005
- PVC/CPVC Flue Gas Exhaust Kit for EDR-2000 4-50-072005
- 2-Inch Ball Valve with 120VAC 2-Position Actuator 2-30-001382
- 4-Inch Butterfly Valve with 120VAC 2-Position Actuator 2-30-001385

- Supply Header Temperature Sensor 4-30-000510
- Outdoor Air Temperature Sensor Kit 4-30-000500
- Domestic Hot Water Temperature Sensor 4-30-315300
- Spare Combustion Air Filter for 750/1000 2-30-071039
- Spare Combustion Air Filter for 1500/2000 2-30-000739
- Outdoor Installation Kit for EDR-750/1000 4-50-001910-37
- Outdoor Installation Kit for EDR-1500/2000 4-50-001909-37
- _____
- _____
- _____
- _____

NOTE:

Information provided in this document is based on standard boiler configurations only. Alternate or custom configurations may result in deviations.

CAPACITIES: STANDARD NATURAL GAS; REFER TO ENGINEERING DATA FOR CAPACITY AT HIGH ELEVATION



Endura Model		EDR-750	EDR-1000	EDR-1500	EDR-2000
Rated Input at High Fire	BTU/hr	750,000	1,000,000	1,500,000	2,000,000
	<i>kW</i>	220	293	440	586
Minimum Input at Low Fire	BTU/hr	90,000	90,000	133,000	133,000
	<i>kW</i>	26	26	39	39
Rated Output (BTS-2000)	BTU/hr	728,250	953,000	1,402,500	1,874,000
	Boiler HP	21.8	28.5	41.9	56.0
	<i>kW</i>	213	279	411	549
Thermal Efficiency (BTS-2000)	%	97.1	95.3	93.5	93.7
Burner Turndown	-	8:1	11:1	11:1	15:1

CONNECTION SIZES:

Endura Model		EDR-750	EDR-1000	EDR-1500	EDR-2000
Boiler Supply Water Outlet	inches	2	2	4	4
	<i>mm</i>	51	51	102	102
Boiler Return Water Inlet	inches	2	2	4	4
	<i>mm</i>	51	51	102	102
Flue Gas Condensate Drain (NPT)	inches	1	1	1	1
	<i>mm</i>	25	25	25	25
Boiler Pressure Vessel Drain (NPT)	inches	1	1	3/4	3/4
	<i>mm</i>	25	25	19	19
Natural Gas Train Inlet (NPT)	inches	1	1	1-1/2	1-1/2
	<i>mm</i>	25	25	38	38
Combustion Air Inlet (ID) <i>(Adapter Required)</i>	inches	6	6	8	8
	<i>mm</i>	152	152	203	203
Minimum Flue Gas Exhaust Vent (ID) <i>(Adapter Required)</i>	inches	6	6	6	8
	<i>mm</i>	152	152	152	203
Boiler Exhaust Outlet (ID)	inches	6	6	6	8
	<i>mm</i>	152	152	152	203
Boiler Exhaust Outlet (OD)	inches	6-1/4	6-1/4	6-1/4	8-1/4
	<i>mm</i>	159	159	159	210

NOTE:

- EDR-750 and EDR-1000 water connections are NPT, the EDR-1500 and EDR-2000 are ANSI 150# FLG.

FUEL REQUIREMENTS: STANDARD NATURAL GAS AT 1,020 BTU/SCF (9,082 KCAL/M³)



Endura Model		EDR-750	EDR-1000	EDR-1500	EDR-2000
Fuel Usage at Rated Input	SCFH	735	980	1,471	1,961
	<i>m³/hr</i>	20.8	27.8	41.7	55.5
Minimum Gas Pressure (Req. at High Fire)	in W.C.	4	4	4	4
	<i>kPa</i>	1	1	1	1
Maximum Gas Pressure	in W.C.	28	28	28	28
	<i>kPa</i>	7	7	7	7

NOTE:

- Canada only: 14 in W.C. maximum gas pressure.

FUEL REQUIREMENTS: STANDARD HD5 PROPANE AT 2,500 BTU/SCF (22,260 KCAL/M³)

Endura Model		EDR-750	EDR-1000	EDR-1500	EDR-2000
Fuel Usage at Rated Input	SCFH	300	400	600	800
	<i>m³/hr</i>	8.5	11.3	17.0	22.7
Minimum Gas Pressure (Req. at High Fire)	in W.C.	7	7	7	7
	<i>kPa</i>	1.74	1.74	1.74	1.74
Maximum Gas Pressure	in W.C.	14	14	14	14
	<i>kPa</i>	3.5	3.5	3.5	3.5

NOTES:

- Endura boilers are factory tested on Natural Gas. Field conversion to Propane during commissioning is required by an authorized service technician.
- Maximum burner turndown ratio up to 4:1 when operating on Propane.
- Model EDR-1500 is not available for propane operation, a derated EDR-2000 is available for these applications with up to 3:1 burner turndown.
- Propane-fired operation is suitable for use with HD5 grade Liquid Petroleum Gases conforming to ASTM D1835-82 only.

ELECTRICAL REQUIREMENTS: APPLIES TO <20 PPM NO_x STANDARD BLOWER AND CONTROLS

Endura Model		EDR-750	EDR-1000	EDR-1500	EDR-2000
Electrical Supply	Volts	120	120	120	120
	∅	1	1	1	1
	<i>Hz</i>	60	60	60	60
Full Load Amps (FLA)	Amps	10	10	20	20
Minimum Current Ampacity (MCA)	Amps	12.5	12.5	25	25
SCCR	Amps	5,000	5,000	5,000	5,000

NOTES:

- Voltages under specification may result in increased amperage and burner de-rate.
- Provide separate power supplies for external devices. Do not power external devices through the boiler control circuits.

WATER AND FLOW REQUIREMENTS: SPECIFICATIONS APPLY TO 100% WATER SYSTEMS; SEE IOM FOR GLYCOL SYSTEMS



Endura Model		EDR-750	EDR-1000	EDR-1500	EDR-2000
Typical Flow Rate at Rated Output 20°F ΔT	GPM	73	95	140	187
	<i>LPM</i>	276	360	530	708
Typical Flow Rate at Rated Output 40°F ΔT	GPM	37	48	70	94
	<i>LPM</i>	138	180	265	354
Water Pressure Drop at Rated Output 20°F ΔT	PSI	0.5	0.7	0.8	1.5
	<i>kPa</i>	3.5	4.8	5.5	10.3
Water Pressure Drop at Rated Output 40°F ΔT	PSI	0.1	0.2	0.2	0.4
	<i>kPa</i>	0.7	1.4	1.4	2.6
Maximum ΔT Capable	°F	100	100	100	100
	°C	55.5	55.5	55.5	55.5
Minimum Flow Rate	GPM	N/A	N/A	N/A	N/A
	<i>LPM</i>				
Maximum Flow Rate	GPM	N/A	N/A	N/A	N/A
	<i>LPM</i>				

NOTES:

- No minimum flow requirement means a low or zero flow situation will not cause harm to the heat exchanger.
- The system will require proper design flow for the given conditions to heat the building and prevent nuisance high limit manual reset lockouts at the boiler.
- Flow rates will vary for glycol systems. Review Engineering Guide for details.
- Refer to the Installation, Operation, and Maintenance Manual for the water pressure drop at flow rates not listed above.

WEIGHTS AND VOLUMES:

Endura Model		EDR-750	EDR-1000	EDR-1500	EDR-2000
Dry Weight	lbs	1,430	1,430	2,260	2,360
	<i>kg</i>	649	649	1,025	1,070
Operating Weight	lbs	1,848	1,848	3,128	3,210
	<i>kg</i>	838	838	1,419	1,456
Approximate Shipping Weight	lbs	1,660	1,660	2,600	2,700
	<i>kg</i>	753	753	1,179	1,225
Pressure Vessel Water Volume	Gallons	50	50	104	102
	<i>Liters</i>	189	189	394	386

VENTING REQUIREMENTS:

Endura Model		EDR-750	EDR-1000	EDR-1500	EDR-2000
Combustion Air Intake Flow Rate	SCFM	153	203	305	407
Flue Gas Exhaust Flow Rate	SCFM	165	220	330	440
	<i>ACFM</i>	203	271	407	543
Minimum Allowable Draft Pressure	in W.C.	-0.04	-0.04	-0.04	-0.04
	<i>kPa</i>	-0.01	-0.01	-0.01	-0.01
Maximum Allowable Draft Pressure	in W.C.	+1.50	+1.50	+1.50	+1.50
	<i>kPa</i>	+0.374	+0.374	+0.374	+0.374

NOTES:

- Maximum draft pressure is the total sum of the venting system and is inclusive of both the flue gas vent and combustion air intake pressure losses.
- Refer to the Installation, Operation, and Maintenance Manual for complete venting guidelines including certifications, materials, common venting requirements.

EMISSIONS: STANDARD NATURAL GAS AT 1,020 BTU/SCF (9,082 KCAL/M³)

Endura Model		EDR-750	EDR-1000	EDR-1500	EDR-2000
NOx	ppm	< 20	< 20	< 20	< 20
CO ₂	%	8 to 10	8 to 10	8 to 10	8 to 10
CO	ppm	< 50	< 50	< 50	< 50
	<i>lbs/hr</i>	0.0268	0.0358	0.0536	0.0715
SOx	<i>g/hr</i>	12.2	16.2	24.3	32.4
	lbs/hr	0.0004	0.0006	0.0009	0.0012
Total Particulates (PM)	<i>g/hr</i>	0.2	0.3	0.4	0.54
	lbs/hr	0.0056	0.0075	0.0112	0.0149
Total Organics (TOC)	<i>g/hr</i>	2.5	3.4	5.08	6.76
	lbs/hr	0.0081	0.0108	0.0162	0.0216
Lead	<i>g/hr</i>	3.7	4.90	7.35	9.80
	lbs/hr	4 × 10⁻⁷	5 × 10⁻⁷	7 × 10⁻⁷	1.0 × 10⁻⁶
Volatile Organic Compounds (VOC)	<i>g/hr</i>	2 × 10 ⁻⁴	2 × 10 ⁻⁴	3 × 10 ⁻⁴	4 × 10 ⁻⁴
	lbs/hr	0.0040	0.0054	0.0081	0.0108
	<i>g/hr</i>	1.8	2.4	3.7	4.90

NOTES:

- NOx and CO are stated at a 3% O₂ correction.
- Emissions data is typical for standard natural gas operation.
- Emissions will vary based on site specific factors and operating parameters.
- Site specific conditions and emissions requirements will determine the appropriate CO₂ settings for each application.
- VOC, SOx, PM, TOC and Lead are achieved through calculation using the AP 42 method as published by the US EPA, and are stated at rated input.
- AP 42, Fifth Edition, Vol 1, Ch 1, Table 1.4-2 determines the emissions components that cannot be measured with a combustion analyzer.
- Jacket losses: 0.2% of output at maximum capacity, IAW ASHRAE Standard 103-2007.

MINIMUM CLEARANCES:

Endura Model		EDR-750	EDR-1000	EDR-1500	EDR-2000
Front	inches	36	36	36	36
	<i>mm</i>	914	914	914	914
Rear	inches	24	24	24	24
	<i>mm</i>	610	610	610	610
Top	inches	18	18	18	18
	<i>mm</i>	457	457	457	457
Sides	inches	1	1	1	1
	<i>mm</i>	25	25	25	25

NOTE:

- Local codes may supersede Fulton clearance requirements.

DIMENSIONS:

Refer to the 7-91 type Product Data Submittal End Assembly Drawing for dimensions.

FIELD CONNECTIONS			
ITEM	DESCRIPTION	SIZE	TYPE
A	SUPPLY WATER OUTLET	4"	150# FLG.
B	FLUE GAS EXHAUST OUTLET (I.D.)	8"	----
C	COMBUSTION AIR INLET (SEE NOTE 6)	8"	----
D	BOILER DRAIN	3/4"	N.P.T.
E	FLUE GAS CONDENSATE DRAIN	1"	N.P.T.
F	RETURN WATER INLET	4"	150# FLG.
G	SAFETY RELIEF VALVE CONNECTION (SEE NOTE 3)	1 1/4"	N.P.T.
H	NATURAL GAS INLET	1 1/2"	N.P.T.
J	ELECTRICAL CONNECTION	----	----

NOTES:

1. FRONT ACCESS DOOR REQUIRES A 34" [864mm] RADIUS SWING HINGED AT LEFT SIDE OF THE BOILER, FRONT CLEARANCE MINIMUM IS 36" [914mm], REAR CLEARANCE MINIMUM IS 24" [610mm], TOP CLEARANCE MINIMUM IS 18" [457mm] & SIDE CLEARANCE MINIMUM IS 1" [25mm].

2. THE PRESSURE VESSEL IS BUILT TO COMPLY WITH ASME SECTION IV.

3. APPROPRIATE SAFETY RELIEF VALVE IS DETERMINED BY TRIM PRESSURE & IS SUPPLIED IN THE TRIM KIT FOR FIELD INSTALLATION. INLET & OUTLET ARE NPT AND SIZES ARE AS FOLLOWS:

- 60# - 1" INLET x 1 1/4" OUTLET
- 100# - 3/4" INLET x 1" OUTLET
- 125# - 3/4" INLET x 1" OUTLET
- 160# - 3/4" INLET x 1" OUTLET

4. FOR ACCESS TO REAR INSPECTION OPENING & ASME STAMPING AREA, BACK COVER PANEL MUST BE REMOVED.

5. ALL DIMENSIONS ARE IN INCHES [MILLIMETERS] & ARE FOR REFERENCE ONLY. THIS DRAWING IS NOT FOR CONSTRUCTION PURPOSES.

6. AIR FILTER HOUSING CAN BE REMOVED AND REINSTALLED IN THE FIELD FOR LOWER CLEARANCE DURING INSTALLATION.

7. REMOVE TOP PANELS TO ACCESS LIFTING EYES.

8. CENTER OF GRAVITY IS ESTIMATED USING CAD MODEL DRY WEIGHT.

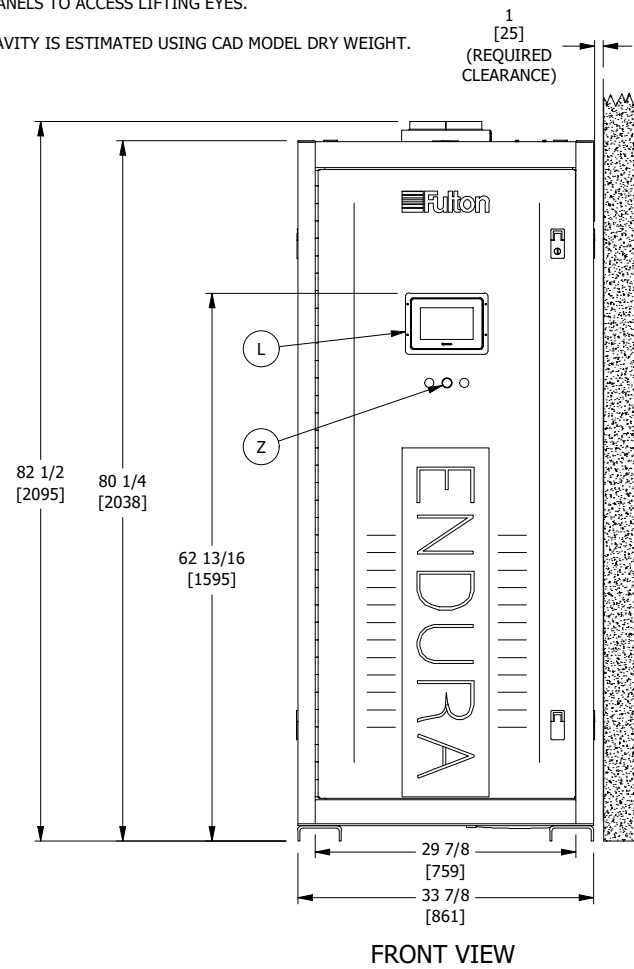

FRONT VIEW

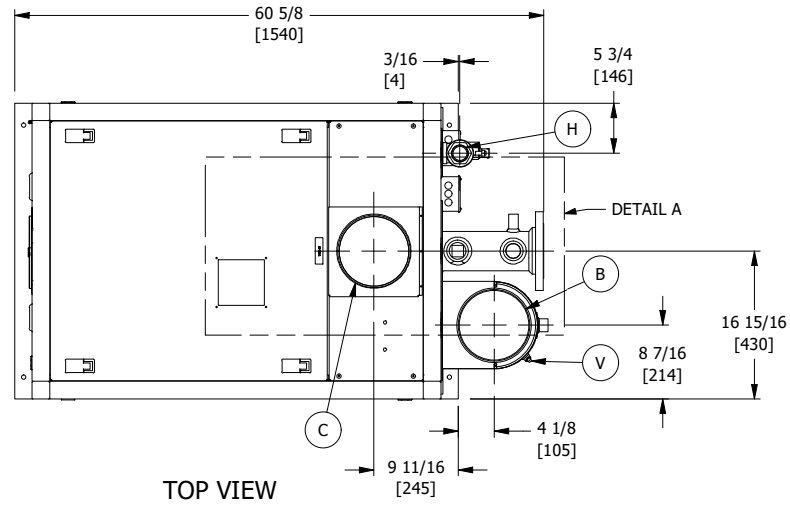

TOP VIEW

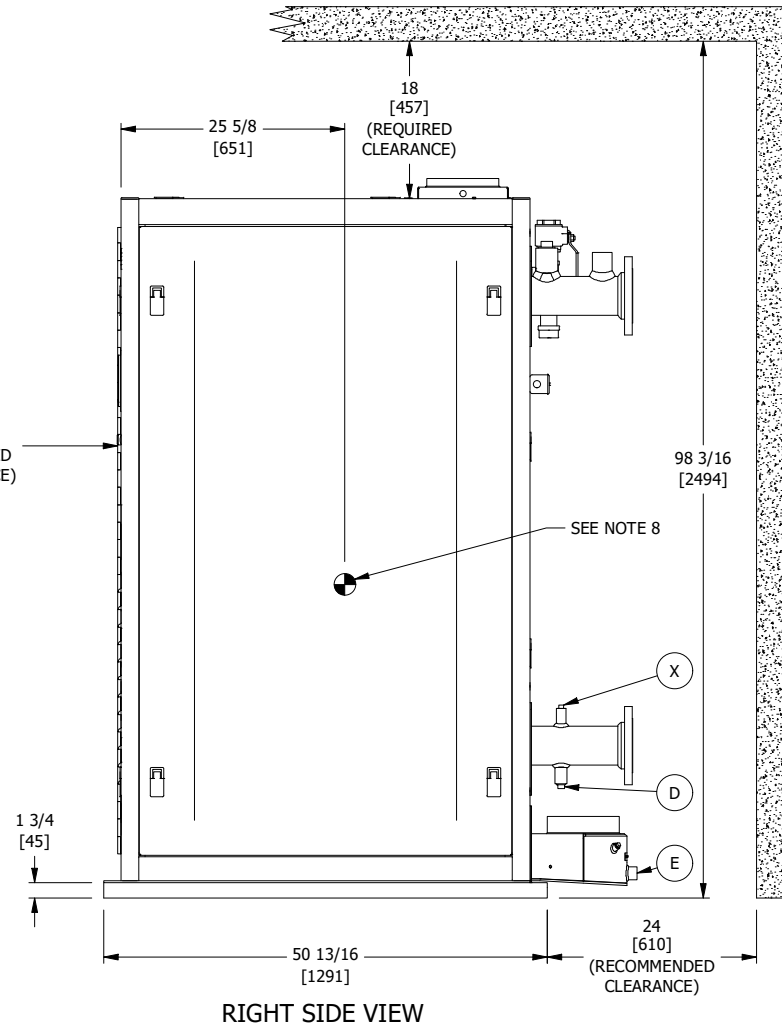

RIGHT SIDE VIEW

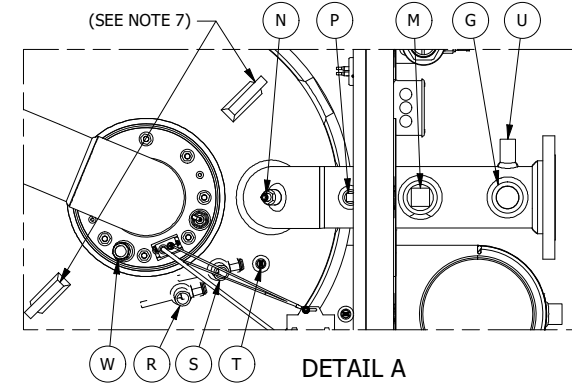

DETAIL A

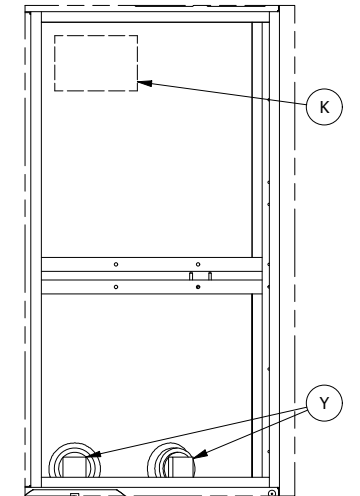

DETAIL B
(SEE NOTE 4)

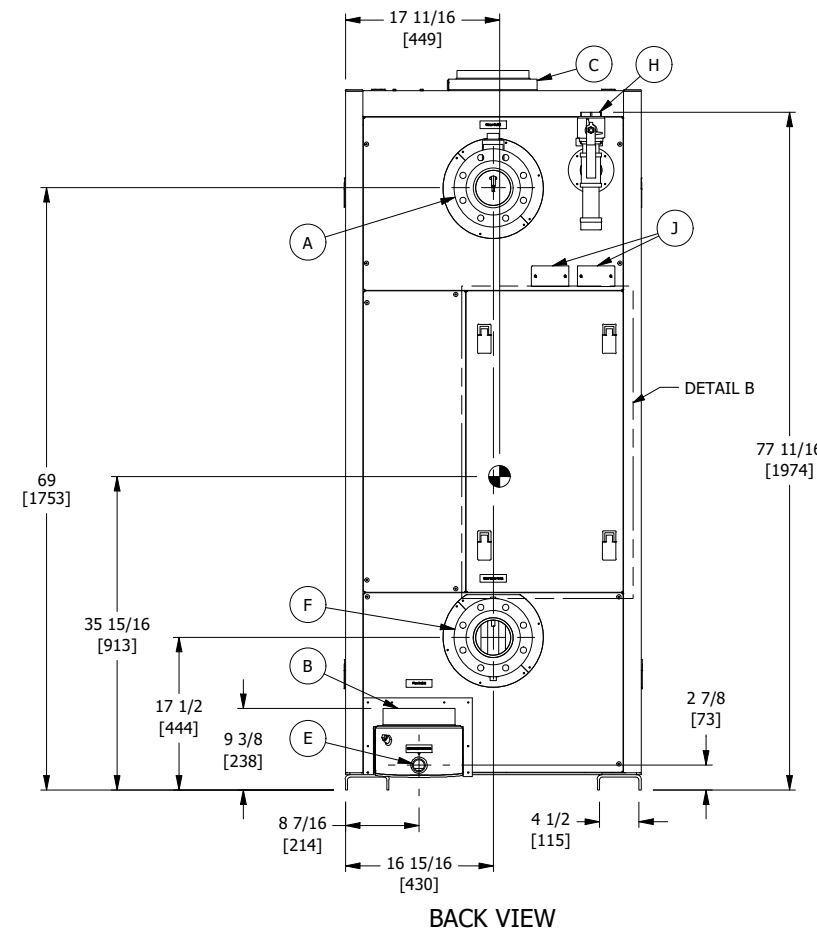

BACK VIEW

CALLOUTS			
ITEM	DESCRIPTION	SIZE	TYPE
K	ASME STAMPING AREA (SEE NOTE 4)	----	----
L	CONTROL DISPLAY	----	----
M	AUXILIARY CONNECTION	1 1/2"	N.P.T.
N	LOW WATER PROBE	1/2"	N.P.T.
P	AUXILIARY SAFETY DEVICE CONNECTION	1/2"	N.P.T.
R	HIGH LIMIT AQUASTAT	1/2"	N.P.T.
S	OPERATING AQUASTAT	1/2"	N.P.T.
T	OPERATING TEMPERATURE SENSOR	1/4"	N.P.T.
U	PRESSURE AND TEMPERATURE GAUGE CONNECTION (FIELD INSTALLED)	1/2"	N.P.T.
V	COMBUSTION ANALYSIS PORT	1/4"	N.P.T.
W	FLAME VIEW PORT	----	----
X	AUXILIARY RETURN WATER INSTRUMENTATION CONNECTION	1/2"	N.P.T.
Y	INSPECTION ACCESS (SEE NOTE 4)	2"	N.P.T.
Z	ON/OFF BUTTON	----	----

REV	REVISION DESCRIPTION	CHECKED	BOM/PLANT	MECH/ELEC	ASME	APPROVED
B	CORRECTED BALLOON FOR PRESSURE AND TEMPERATURE GAUGE CONNECTION (FIELD INSTALLED) FROM "S" TO "U" P.J.D. 4/26/2024	N/A	N/A	A.R.P. 4/29/2024	N/A	K.D.B. 4/29/2024
REVISION HISTORY						

This design and drawings are proprietary and are the exclusive property of The Fulton Companies. The corporation does not permit their use except with prior written consent.

The items shown in this drawing may be covered by one or more patents of The Fulton Companies.

DRAWN BY: T. BETTS 9/28/2020	MECHANICAL / ELECTRICAL REVIEW: A. PEDROSA 10/2/2020	JOB NUMBER:
CHECKED BY: N/A	ASME REVIEW: N/A	PROJECT NAME:
B.O.M. / PLANT REVIEW: N/A	APPROVED BY: K. BOTTORFF 10/2/2020	PROJECT MANAGER:

DESCRIPTION:
ENDURA 2000K PURE CONTROL CONDENSING HYDRONIC BOILER END ASSEMBLY

SHEET 1 OF 1

DRAWING NUMBER
7-91-082000-PDS

REVISION
B

SUBJECT:
Thermal Efficiency Curve

ENDURA (EDR) SERIES:
EDR-2000

DATE:
October 20, 2021

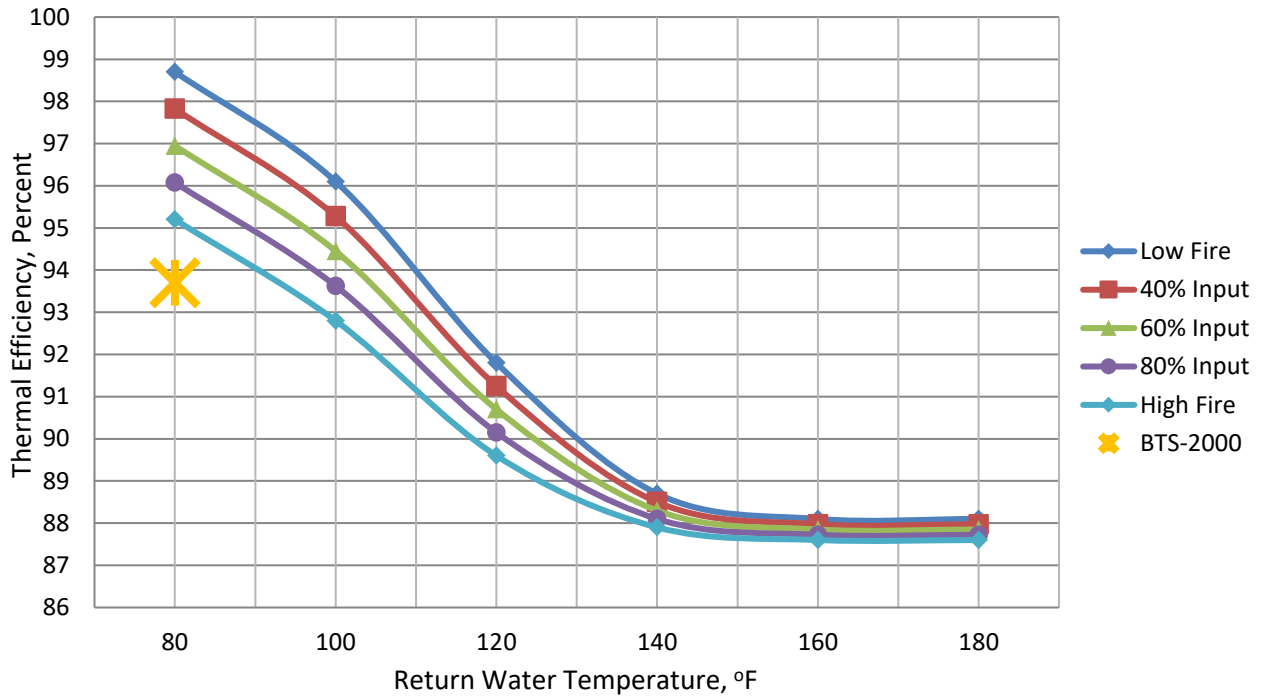

Notes:

1. Laboratory data collected by Fulton research & development.
2. Thermal efficiency curves obtained using a 20°F differential temperature and modified methodology from the BTS-2000 test procedures.
3. Field performance may vary based on site conditions, maintenance history, and combustion parameters configured by the service technician.
4. Fuel is standard natural gas.

Certificate of Product Ratings

AHRI Certified Reference Number: 6305705

Date: 2/15/2017

†Status: Active

Product: Commercial Boiler Heating Equipment

Model Number: EDR-2000

Manufacturer: FULTON HEATING SOLUTIONS

Trade/Brand name: FULTON HEATING SOLUTIONS

Series Name: Endura

Rated as follows in accordance with Department of Energy (DOE) Boiler test procedures as published in the latest edition of the Code of Federal Regulations, 10 CFR Part 431 and subject to verification of rating accuracy by AHRI-sponsored, independent, third party testing:

Combustion Efficiency:	92.7 %
Thermal Efficiency:	93.7 %

The following data is for reference only and is not certified by AHRI:

Material:	Stainless Steel
Location:	Indoor
Fuel Type:	Natural Gas
Input:	2000 MBTUH
Gross Output:	1874 MBTUH
Ignition Type:	Intermittent/Electronic Ignition
Heating Medium:	Water
Draft Type:	Forced Draft
CO2:	10.0

* Ratings followed by an asterisk (*) indicate a voluntary rerate of previously published data, unless accompanied with a WAS, which indicates an involuntary rerate.

DISCLAIMER

AHRI does not endorse the product(s) listed on this Certificate and makes no representations, warranties or guarantees as to, and assumes no responsibility for, the product(s) listed on this Certificate. AHRI expressly disclaims all liability for damages of any kind arising out of the use or performance of the product(s), or the unauthorized alteration of data listed on this Certificate. Certified ratings are valid only for models and configurations listed in the directory at www.ahridirectory.org.

TERMS AND CONDITIONS

This Certificate and its contents are proprietary products of AHRI. This Certificate shall only be used for individual, personal and confidential reference purposes. The contents of this Certificate may not, in whole or in part, be reproduced; copied; disseminated; entered into a computer database; or otherwise utilized, in any form or manner or by any means, except for the user's individual, personal and confidential reference.

CERTIFICATE VERIFICATION

The information for the model cited on this certificate can be verified at www.ahridirectory.org, click on "Verify Certificate" link and enter the AHRI Certified Reference Number and the date on which the certificate was issued, which is listed above, and the Certificate No., which is listed at bottom right.

©2014 Air-Conditioning, Heating, and Refrigeration Institute



we make life better™

CERTIFICATE NO.: 131316466090612000

SUBJECT:
Water Side Pressure Drop

ENDURA (EDR) SERIES:
EDR-750, EDR-1000, EDR-1500, EDR-2000

DATE:
October 20, 2021

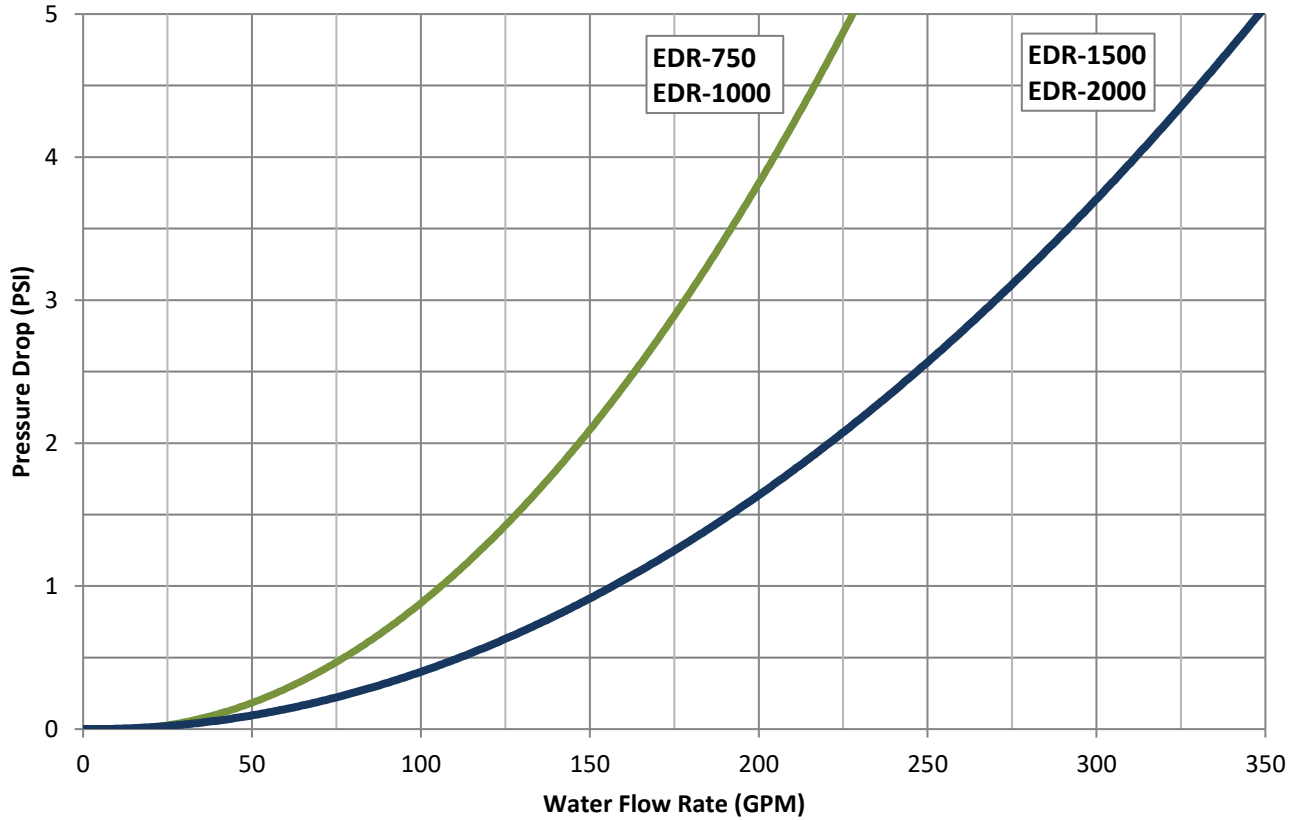

Notes:

1. Laboratory data collected by Fulton research & development.
2. Endura (EDR) series boilers do not have a minimum or maximum flow rate required to protect the heat exchanger, however, as is the case with any hydronic boiler, proper design flow will be required to properly heat the building and avoid nuisance safety device lockout conditions.
3. Always consider the major and minor losses associated with piping, fittings and valves in addition to the boiler when selecting pumps.

BOM FOR REFERENCE ONLY

ITEM	PART #	DESCRIPTION	TAGS	QTY
1	- - -	PROOF OF CLOSURE	POC	1
2	2- 20- 000023	LOW WATER CUTOFF PROBE	LWCP1 LWCP2	2
3	2- 20- 082010- 37	FLAME ROD	FR	1
4	2- 30- 000003	MAIN GAS VALVE	MV1	1
5	2- 30- 005098	COMBUSTION AIR SWITCH	AS	1
6	2- 30- 071646- 37 - PURE	BURNER MOTOR	BM	1
7	2- 40- 000251	OPERATING TEMPERATURE CONTROL	OTC	1
8	2- 40- 000294	HIGH LIMIT TEMP CONTROL	HLTC	1
9	2- 40- 000387	LOW GAS PRESSURE SWITCH	LGP	1
10	2- 40- 000390	HIGH GAS PRESSURE SWITCH	HGP	1
11	2- 40- 000421	WATER LEVEL SAFETY RELAY 120VAC	LWSR1	1
12	2- 40- 000423	11 PIN RELAY BASE	LWSRB1 LWSRB2	2
13	2- 40- 000474	SIEMENS PLUG CONNECTOR SET	FPSS	1
14	2- 40- 000476	FLAME PROGRAMMER LMV36 120VAC	FP	1
15	2- 40- 000976	15.6KVA TRANSFORMERS	IT1	1
16	2- 40- 002104	FUEL SERVO MOTOR	SM2	1
17	2- 45- 000371	1 POLE 30 AMP FUSE HOLDER CLASS CC	1- 30- CC	1
18	2- 45- 000519	30 AMP CUBEFUSE HOLDER TCFH30N	H30A	1
19	2- 45- 000802	SINGLE CIRCUIT GROUND TERMINAL BLOCK	SHLD	1
20	2- 45- 000912	RS232- RS485 MODULE CVM(OCI)	CVM(OC1)	1
21	2- 45- 001235	1 POLE SIGNAL RELAY 120VAC	CR01 CR02 CR03 CR04	4
22	2- 45- 315001	COLOR SCREEN	HMIPLC	1
23	2- 45- 315004	MODULE 2	MODULE 2	1
24	2- 45- 315004	MODULE 3	MODULE 3	1
25	2- 45- 315005	MODULE 4	MODULE 4	1
26	2- 45- 315007	PLC CPU MODULE	MODULE CPU	1
27	2- 45- 315009	N.O. LIGHTED PUSH BUTTON	PB1	1
28	2- 45- 315110	CONTACT BLOCK	CB	1
29	2- 45- 315011	24VDC SLIM LINE 1 POLE CONTROL RELAY	CR06 CR08 CR09 CR10 CR11 CR12 CR13 CR14 CR16 CR18 CR19	11
30	2- 45- 315114	LED LIGHT 120VAC	LED	1
31	2- 45- 315121	MODULE 1	MODULE 1	1
32	2- 45- 315124	ETHERNET HUB	EH	1
33	2- 45- 880400	CONTROL RELAY 24VDC	CR07 CR15	2
34	2- 45- 315901	POWER SUPPLY 120VAC - 24VDC	PS	1
35	2- 50- 315301	STAINLESS STEEL PT100 SENSOR	RTD1 RTD3	2
36	2- 50- 31502	BRASS PT100 SENSOR	RTD2 RTD4	2
37	SEE FUSE TABLE	CUBE FUSE	F1	1

- NOTES:
- (---) INDICATES FIELD WIRING AND/OR FUSED SWITCH BY OTHERS.
 - (---) INDICATES WIRE AND CONDUIT SUPPLIED BY FULTON, INSTALLED BY INSTALLER.
 - LOW WATER TEST: PRESS SCREEN BUTTON TO RESET.
 - REMOVE JUMPER BETWEEN TERMINAL BLOCKS SHOWN TO UTILIZE CONNECTION.
 - ISOLATION VALVES SUPPLIED AND WIRED BY OTHERS.
 - (---) INDICATES WIRING TERMINATED BY FINAL ASSEMBLY AND PANEL ASSEMBLY.
 - MODULES THAT REQUIRE POWER NEED INDIVIDUAL DIRECT POWER SUPPLY FROM TB3.
 - RS232 PORT NOT TERMINATED.
 - (---) INDICATES FACTORY FINAL WIRING.

Note: This drawing reflects the current standard production print and is for reference purposes. Always refer to the schematic inside the boiler cabinet for the print specific to a boiler.

THIS DRAWING SUPERSEDES DRAWING NUMBER 7- 53- 082500

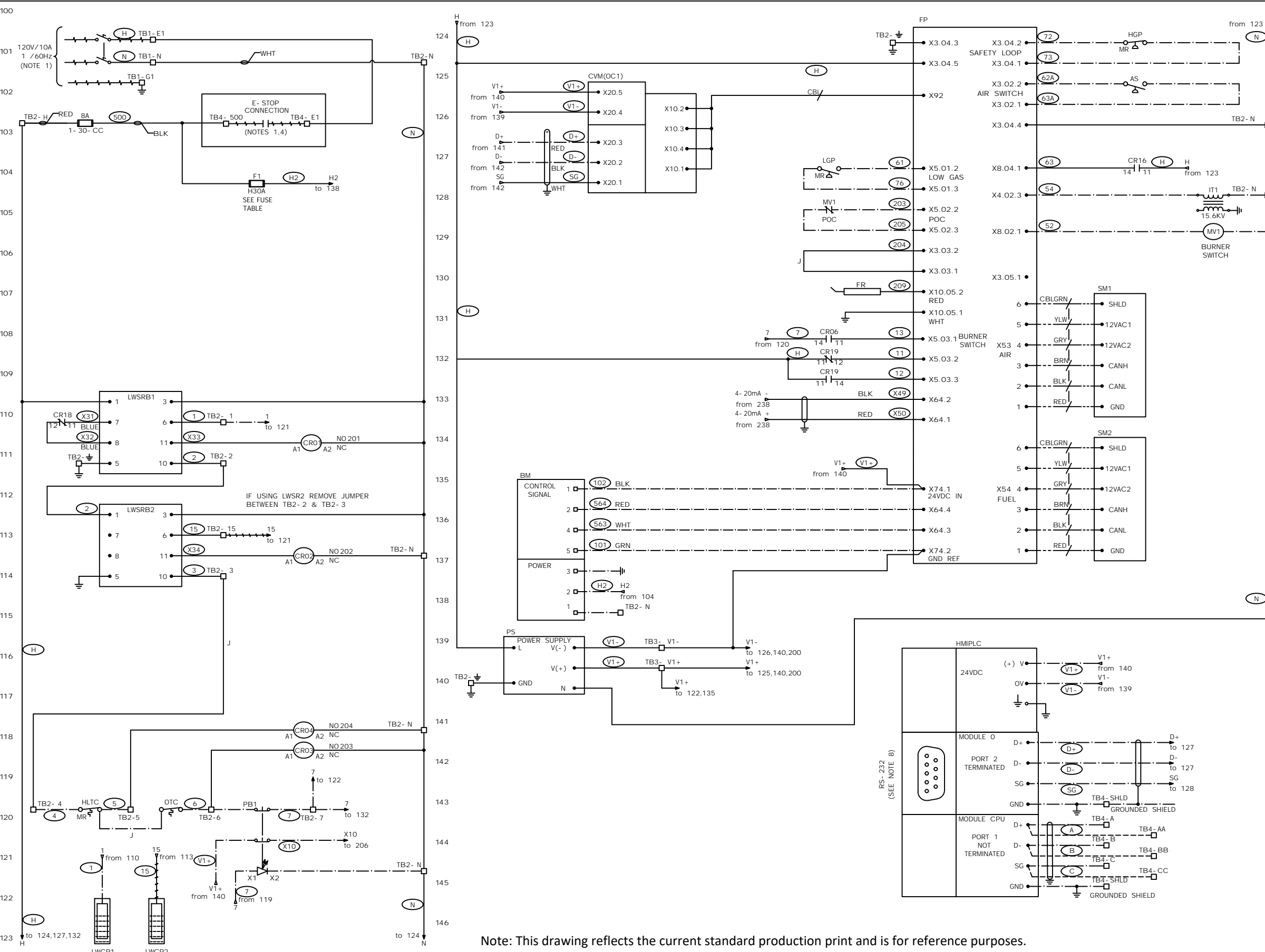

REV	REVISION DESCRIPTION	CHECKED	BOM/PLANT	MECH/ELEC	ASME	APPROVED
A	REMOVED TERMINALS P2SG, P2+, & PS- PER EC 2021-2671. AMK 5/10/21 COMBINED 7-53-081500 & 7-53-082500 INTO 7-53-081500 PER EC 2021-2671. T.B. 5/19/21	JMH 6/1/21	MEA 6/1/21	AMK 5/26/21	N/A	MEA 6/1/21

UNLESS OTHERWISE NOTED, DIMENSIONS ARE IN INCHES. TOLERANCES ON FRACTIONS & WHOLE VALUES: (1) PLACE DEC. -0.03 (2) PLACE DEC. -0.015 (3) PLACE DEC. -0.005 ANGLE SURFACE FINISH 250 MICRO-INCHES

This design and drawings are proprietary and are the exclusive property of Fulton Heating Solutions, Inc. The corporation does not permit their use except with prior written consent.

The items shown in this drawing may be covered by one or more patents of Fulton Heating Solutions, Inc.

DRAWN BY:	A. KLYMKOW	7/17/20	MECHANICAL / ELECTRICAL REVIEW:	D.H.D.	11/23/20
CHECKED BY:	M.E.A.	11/20/20	ASME REVIEW:	N/A	N/A
B.O.M. / PLANT REVIEW:	S.M.	12/4/20	APPROVED BY:	T.T.	11/25/20

JOB NUMBER: PROJECT NUMBER: PROJECT MANAGER:

DESCRIPTION: EDR 750 PURE, 1000 PURE, 1500 PURE, 2000 PURE ELECTRICAL PANELS

Fulton
Fulton Thermal Corporation

DRAWING NUMBER: 7-53-081500

REV: A

SHEET 1 OF 9

200
201
202
203
204
205
206
207
208
209
210
211
212
213
214
215
216
217
218
219
220
221
222
223

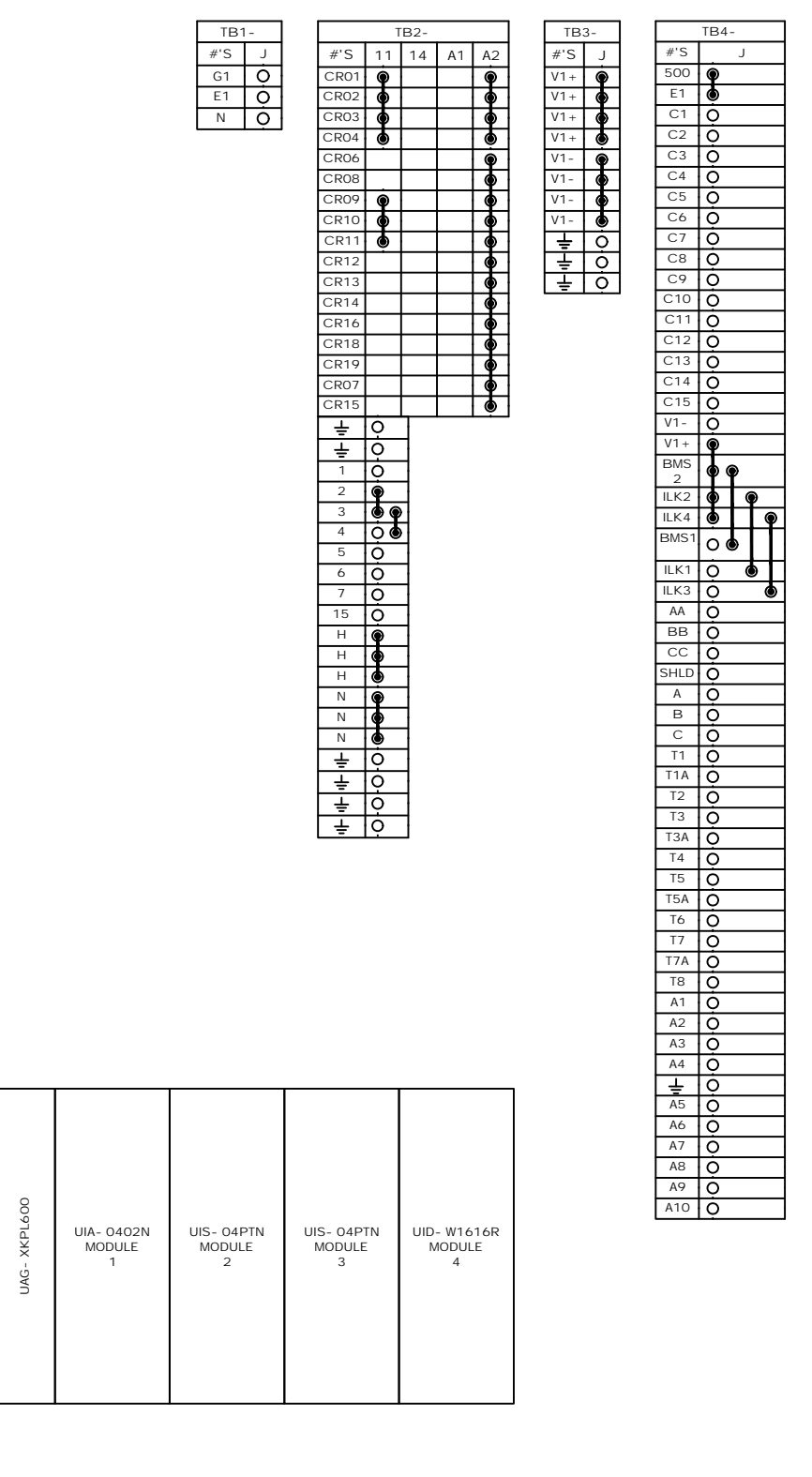
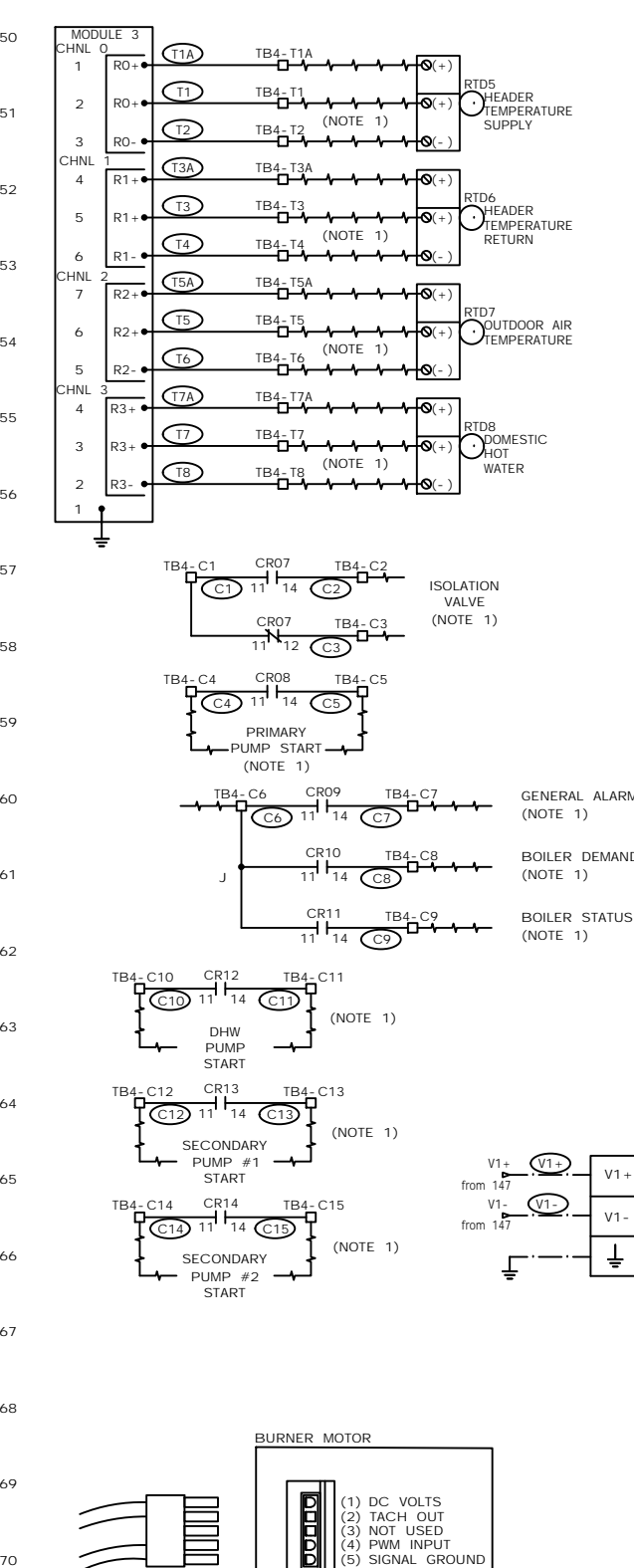
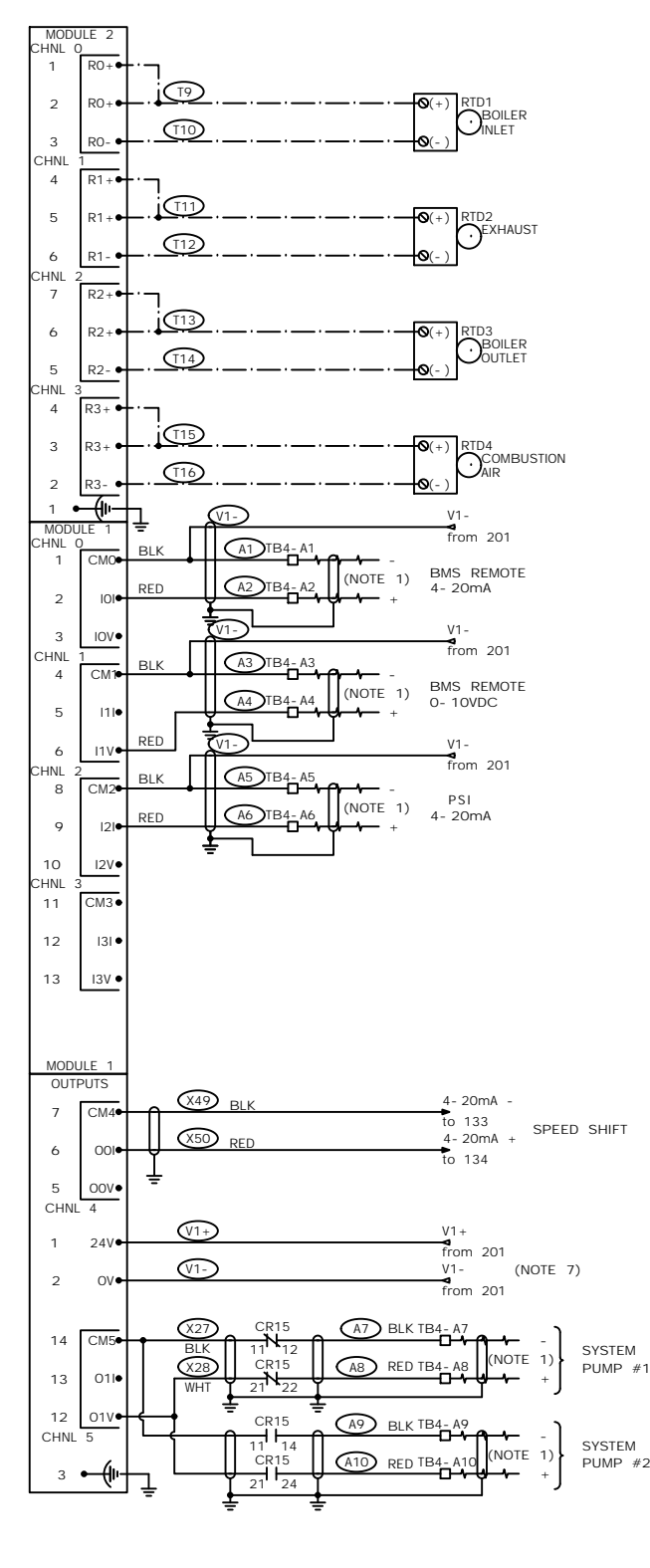
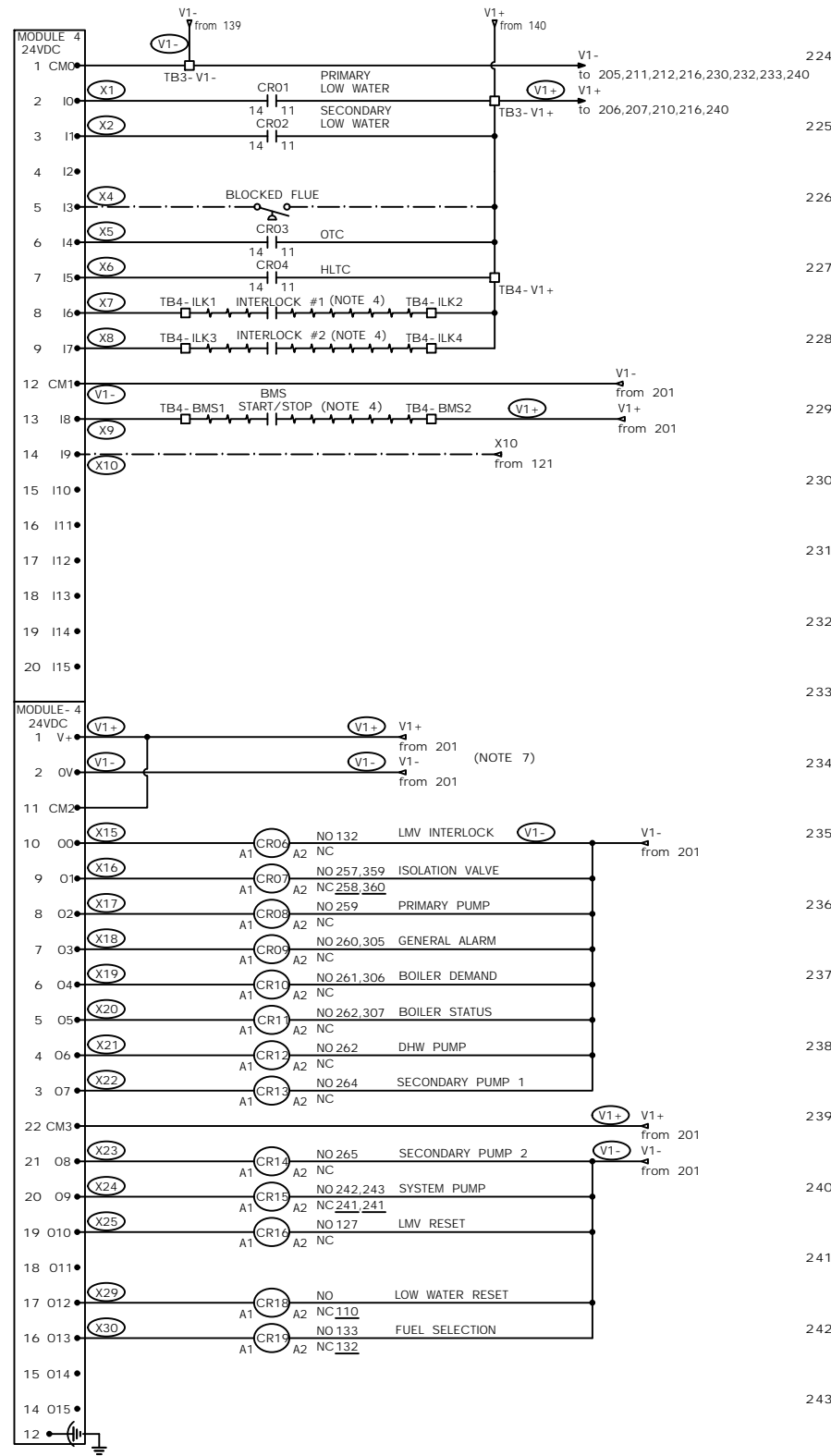

- NOTES:
- (---) INDICATES FIELD WIRING AND/OR FUSED SWITCH BY OTHERS.
 - (---) INDICATES WIRE AND CONDUIT SUPPLIED BY FULTON, INSTALLED BY INSTALLER.
 - LOW WATER TEST: PRESS SCREEN BUTTON TO RESET.
 - REMOVE JUMPER BETWEEN TERMINAL BLOCKS SHOWN TO UTILIZE CONNECTION.
 - ISOLATION VALVES SUPPLIED AND WIRED BY OTHERS.
 - (---) INDICATES WIRING TERMINATED BY FINAL ASSEMBLY AND PANEL ASSEMBLY.
 - MODULES THAT REQUIRE POWER NEED INDIVIDUAL DIRECT POWER SUPPLY FROM TB3.
 - RS232 PORT NOT TERMINATED.
 - (---) INDICATES FACTORY FINAL WIRING.

THIS DRAWING SUPERSEDES DRAWING NUMBER 7- 53- 082500

REV	REVISION DESCRIPTION	CHECKED	BOM/PLANT	MECH/ELEC	ASME	APPROVED
A	REMOVED TERMINALS P2SG, P2+, & PS- PER EC 2021-2671. AMK 5/10/21 COMBINED 7-53-081500 & 7-53-082500 INTO 7-53-081500 PER EC 2021-2671. T.B. 5/19/21	JMH 6/1/21	MEA 6/1/21	AMK 5/26/21	N/A	MEA 6/1/21

UNLESS OTHERWISE NOTED, DIMENSIONS ARE IN INCHES. FRACTIONS & 1/8 WHOLE VALUES (1) PLACE DEC. 0.03 (2) PLACE DEC. 0.015 (3) PLACE DEC. 0.005 ANGLE 0.5 DEG. SURFACE FINISH 250 MICRO-INCHES.

This design and drawings are the exclusive property of Fulton Heating Solutions, Inc. The corporation does not permit their use except with prior written consent.

The items shown in this drawing may be covered by one or more patents of Fulton Heating Solutions, Inc.

DRAWN BY:	A. KLYMKOW	7/17/20	MECHANICAL / ELECTRICAL REVIEW:	D.H.D.	11/23/20
CHECKED BY:	M.E.A.	11/20/20	ASME REVIEW:	N/A	N/A
APPROVED BY:	S.M.	12/4/20	APPROVED BY:	T.T.	11/25/20

JOB NUMBER:	
PROJECT NAME:	
PROJECT MANAGER:	

DESCRIPTION:
EDR 750 PURE, 1000 PURE, 1500 PURE, 2000 PURE ELECTRICAL PANELS

Fulton
Fulton Thermal Corporation

DRAWING NUMBER: 7-53-081500

REV: A

SHEET 2 OF 9

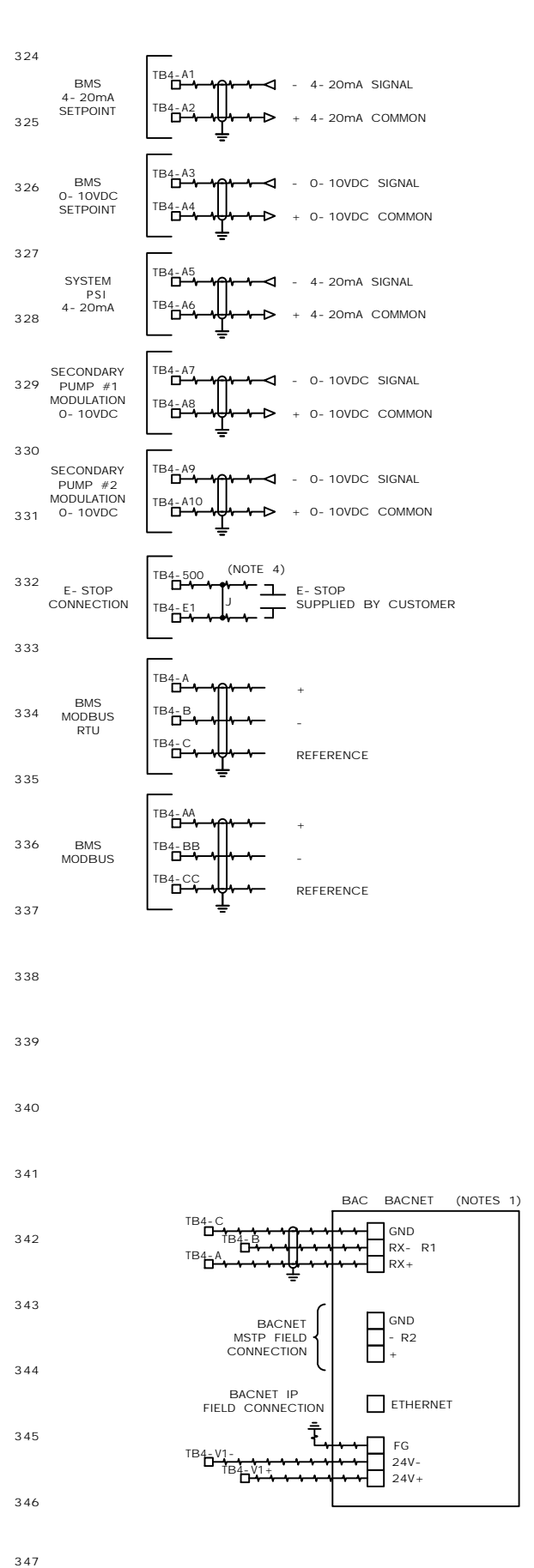
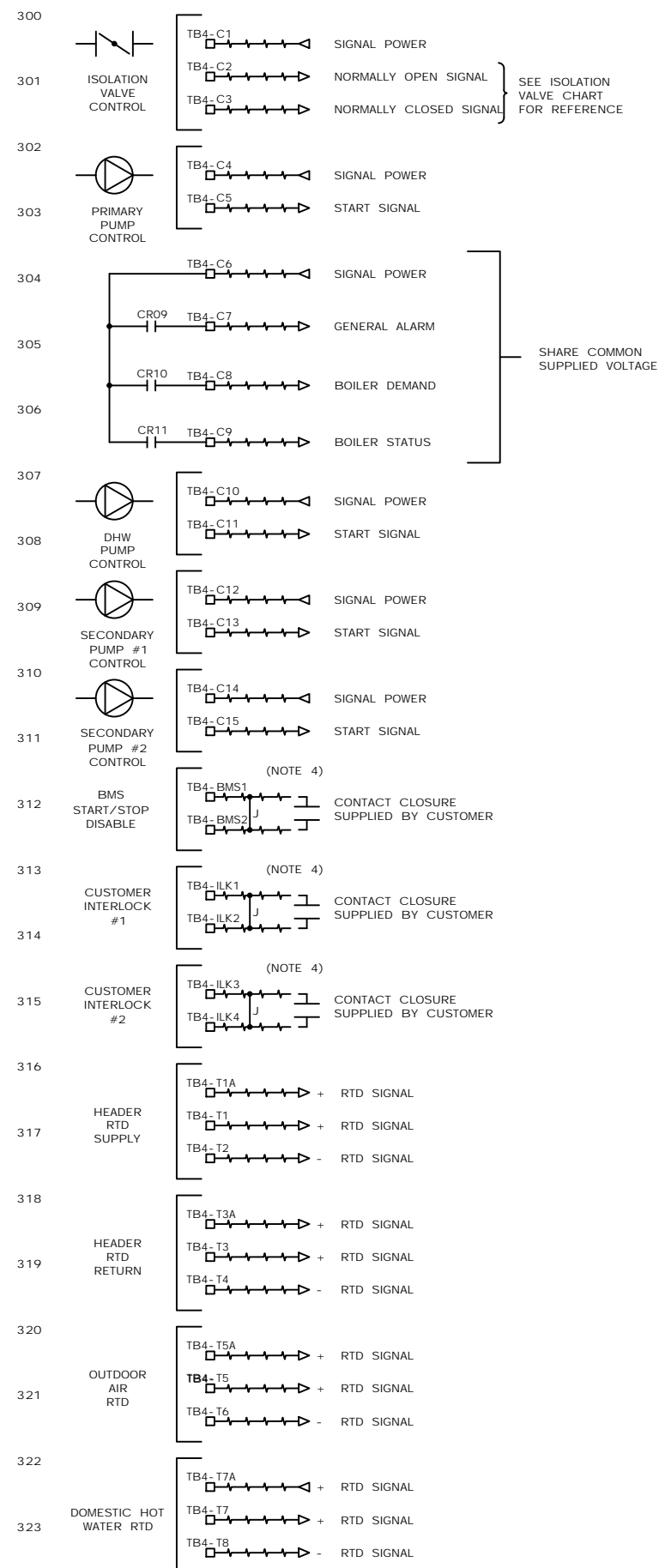

FUSE TABLE			
MODEL	F1	P/N	DESCRIPTION
750 / 1000 PURE	15A	2- 45- 000517	15 AMP CUBE FUSE TCF15
1500 / 2000 PURE	25A	2- 45- 000535	25 AMP CUBE FUSE TCF25

OPTIONAL COMPONENTS BOM FOR REFERENCE ONLY

Installation: OPTIONAL		Location: BACNET	
FULTON P/N	DESCRIPTION	TAG	QTY
2- 45- 001058	PROGRAMMED BACNET MODULE	BAC	1

Installation: OPTIONAL		Location: OUTDOOR SENSOR	
FULTON P/N	DESCRIPTION	TAG	QTY
4- 30- 000500	OUTDOOR TEMPERATURE SENSOR KIT	OTSK	1

Installation: OPTIONAL		Location: 2ND LOW WATER	
FULTON P/N	DESCRIPTION	TAG	QTY
2- 20- 000023	3" LOW WATER PROBE	LWP	1
4- 30- 000330	WATER LEVEL SAFETY RELAY KIT	LWSR2	1

Installation: OPTIONAL		Location: SUPPLY HEADER TEMP SENSOR	
FULTON P/N	DESCRIPTION	TAG	QTY
4- 30- 000510	HEADER SENSOR KIT	HS	1

Installation: OPTIONAL		Location: DHW TEMP SENSOR	
FULTON P/N	DESCRIPTION	TAG	QTY
2- 50- 315301	DOMESTIC TEMPERATURE SENSOR KIT	DTS	1

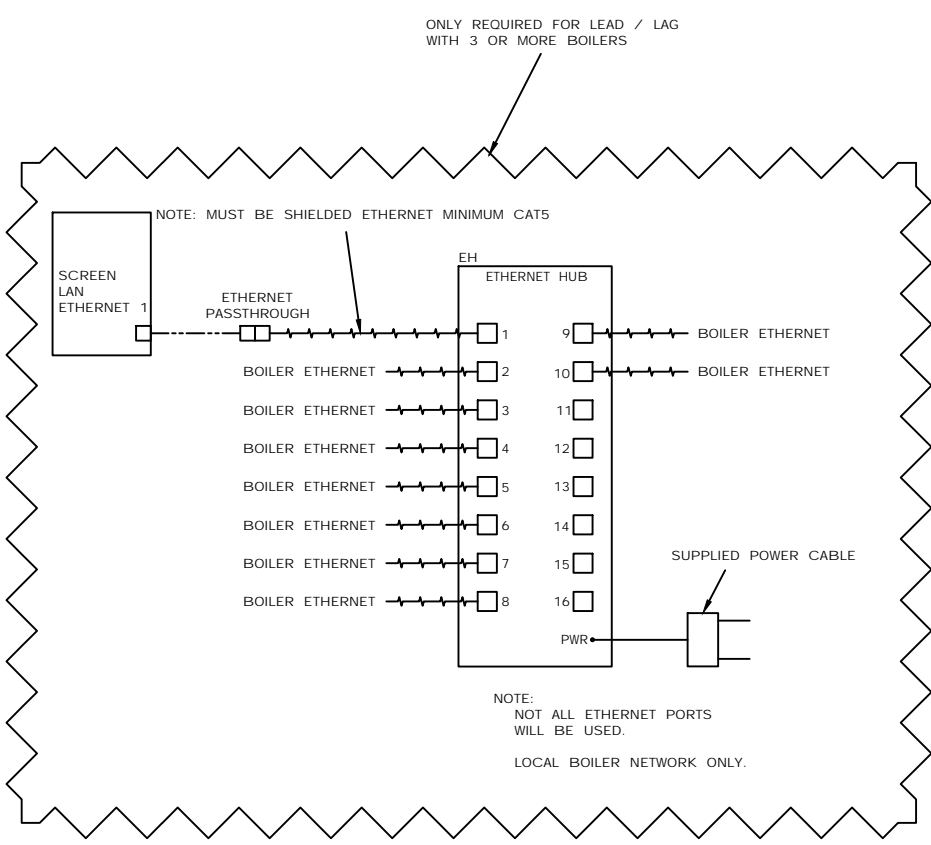
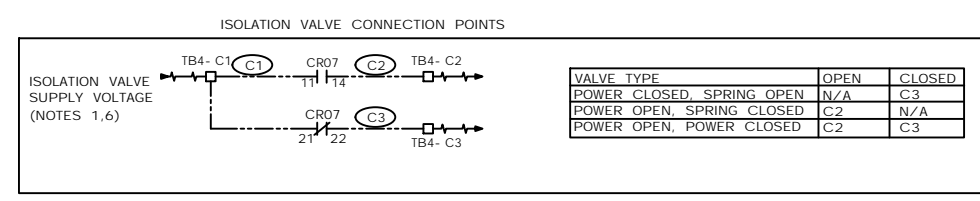

- NOTES:
- (---) INDICATES FIELD WIRING AND/OR FUSED SWITCH BY OTHERS.
 - (---) INDICATES WIRE AND CONDUIT SUPPLIED BY FULTON, INSTALLED BY INSTALLER.
 - LOW WATER TEST: PRESS SCREEN BUTTON TO RESET.
 - REMOVE JUMPER BETWEEN TERMINAL BLOCKS SHOWN TO UTILIZE CONNECTION.
 - ISOLATION VALVES SUPPLIED AND WIRED BY OTHERS.
 - (---) INDICATES WIRING TERMINATED BY FINAL ASSEMBLY AND PANEL ASSEMBLY.
 - MODULES THAT REQUIRE POWER NEED INDIVIDUAL DIRECT POWER SUPPLY FROM TB3.
 - RS232 PORT NOT TERMINATED.
 - (---) INDICATES FACTORY FINAL WIRING.

CUSTOMER CONNECTIONS

THIS DRAWING SUPERSEDES DRAWING NUMBER 7- 53- 082500

A	REMOVED TERMINALS P2SG, P2+, & PS- PER EC 2021-2671. AMK 5/10/21 COMBINED 7-53-081500 & 7-53-082500 INTO 7-53-081500 PER EC 2021-2671. T.B. 5/19/21	JMH 6/1/21	MEA 6/1/21	AMK 5/26/21	N/A	MEA 6/1/21
REV	REVISION DESCRIPTION	CHECKED	BOM/PLANT	MECH/ELEC	ASME	APPROVED
REVISION HISTORY						

UNLESS OTHERWISE NOTED: DIMENSIONS ARE IN INCHES TOLERANCES ON FRACTIONS & WHOLE VALUES (1) PLACE DEC. (2) PLACE DEC. (3) PLACE DEC. ANGLE SURFACE FINISH 250 MICRO-INCHES	This design and drawings are proprietary and are the exclusive property of Fulton Heating Solutions, Inc. The corporation does not permit their use except with prior written consent.	The items shown in this drawing may be covered by one or more patents of Fulton Heating Solutions, Inc.	DRAWN BY: A. KLYMKOW 7/17/20 CHECKED BY: M.E.A. 11/20/20 B.O.M. / PLANT REVIEW: S.M. 12/4/20	MECHANICAL / ELECTRICAL REVIEW: D.H.D. 11/23/20 ASME REVIEW: N/A APPROVED BY: T.T. 11/25/20	JOB NUMBER: PROJECT NAME: PROJECT MANAGER:
--	--	---	--	---	--

EDR 750 PURE, 1000 PURE, 1500 PURE, 2000 PURE ELECTRICAL PANELS	SHEET 3 OF 9
---	--------------

Fulton
Fulton Thermal Corporation

DRAWING NUMBER: 7-53-081500	REV: A
---------------------------------------	------------------

Supply Header Temperature Sensor Kit:

PT100 RTD with Insertion Well

FOR USE WITH:

ModSync, Endura (EDR) and Endura+ (EDR+) PURE Control

OVERVIEW

The supply header temperature sensor kit (PN 4-30-000510) is used in multiple boiler applications where the Fulton ModSync or EDR/EDR+ PURE Control™ are controlling boiler lead/lag. This kit is not for use with the Endura XE (EXE) series PURE Control.

This kit includes a 1/2" NPT insertion well, heat conducting compound, a 1/2" x 1/4" reducing bushing, and a 4" PT100 RTD.

SPECIFICATIONS

- Tolerance: Class B
- Temp. Range: -58 to 392°F (-50 to 200°C)
- Connection: 3-wire
- Lead Length: 180 inch (457 cm)

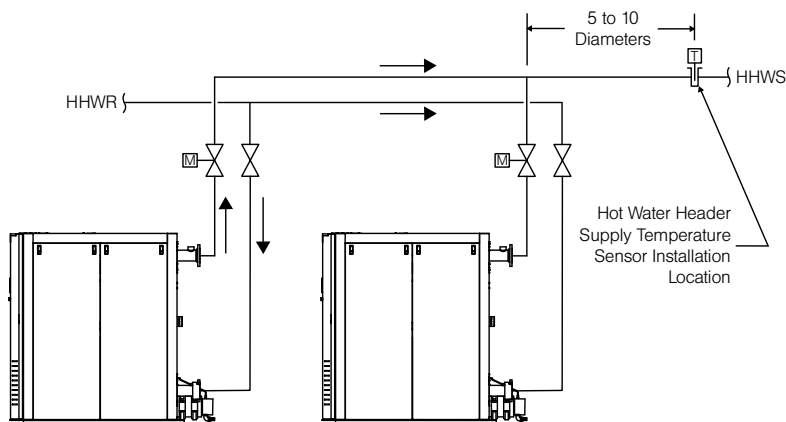

Figure 1 - Variable Primary Piping

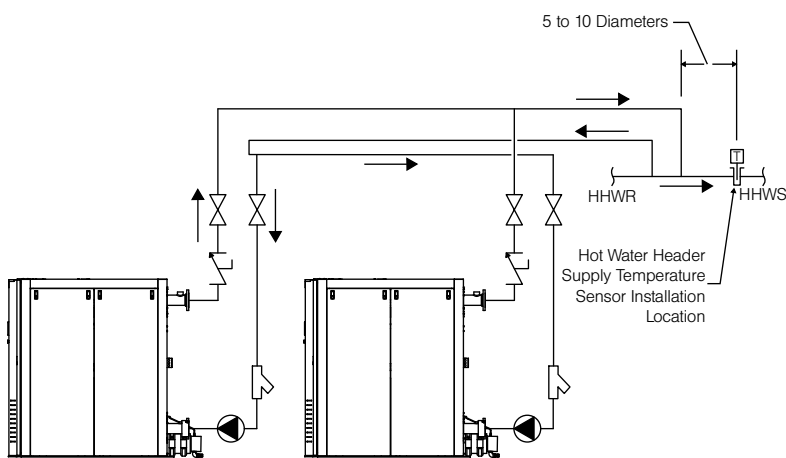

Figure 2 - Primary-Secondary Piping



INSTALLATION REQUIREMENTS

1. Install the insertion well downstream of the last boiler in the common supply header piping.
2. Ensure both the chosen location and the depth will effectively read a blended temperature.
3. For variable primary piping arrangements (Fig 1) install the sensor in the common supply header 5 to 10 pipe diameters downstream of the last boiler tie in point.
4. For primary-secondary piping arrangements (Fig 2), install the sensor in the secondary (system) supply piping, 5 to 10 piping diameters downstream of the primary manifold tie in point.
5. When extending the wire lead, use 18 to 22awg twisted 3 conductor stranded copper with insulated jacket. Ensure connections are tight with no shorts. Soldered with heat shrink tubing connections are strongly recommended.
6. Do not use wire nuts to join lead to extension.
7. Use of 3-wire connections is recommended.
8. Some applications may allow for a 2-wire connection to the control device where the red leads from the RTD are joined. A 2-wire connection may result in less accurate measurements.
9. This sensor may also be installed in the common return piping for the purpose of monitoring of return water temperature. This is in addition to the supply header sensor. Return water temperature must never be used as a process variable.

Flue Gas Condensate Trap:

For Single Boiler Installation up to 6,000,000 BTU/hr

FOR USE WITH:

Fulton Condensing Boilers

OVERVIEW

The single boiler condensate drain trap (PN 4-57-005500) will allow for the safe drainage and disposal of flue gas condensate, while preventing flue gases from escaping into the boiler room. Condensate drain traps are required for every Fulton condensing boiler installation.

The outlet of the condensate drain trap is piped to either the inlet of the pH Neutralization Kit, or to an open floor drain.

SPECIFICATIONS

- Material: Cast Aluminum
- Inlet: 3/4" NPT
- Outlet: 3/4" NPT
- Capacity: Maximum 6,000,000 BTU/hr
- Pad Height: Minimum 4" (102 mm) Required

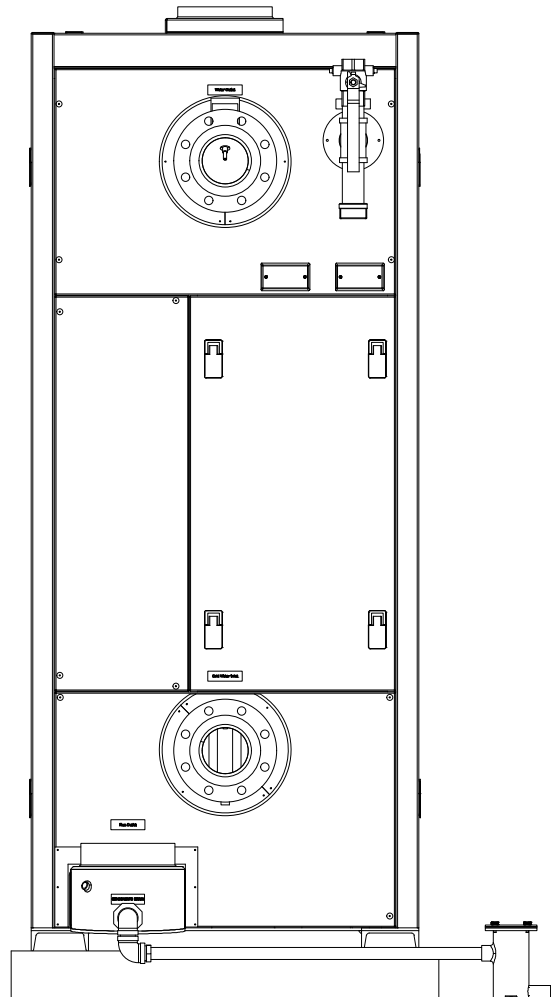

INSTALLATION REQUIREMENTS

1. Minimum 4-inch (102 mm) boiler housekeeping pad height required.
2. Install the trap at floor level, a minimum of 4-inches (102 mm) below the boiler housekeeping pad.
3. Verify inlet and outlet orientation is correct.
4. One trap is required per each boiler.
5. The piping must be pitched downward towards the condensate drain trap and the floor drain.
6. Copper, carbon steel/iron pipe, and PVC are not acceptable drain piping materials.
7. Installation and piping material requirements vary by boiler type and model, refer to the respective boiler Installation, Operation and Maintenance Manual for product specific requirements.
8. A pipe reducer (not supplied) and additional fittings may be required.
9. Not for use with Pulse combustion boilers.

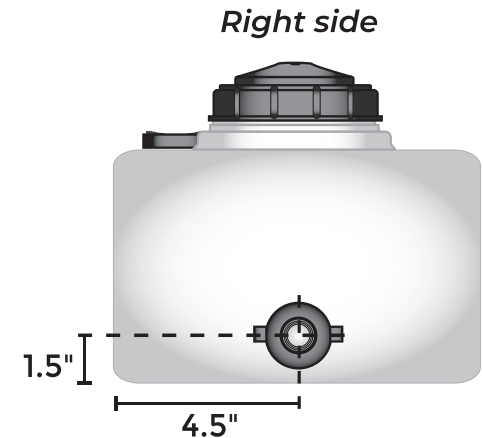
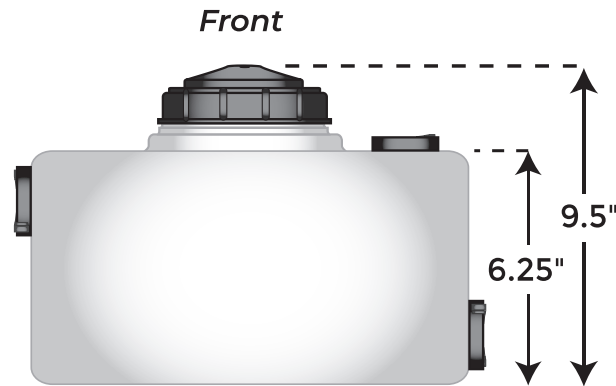
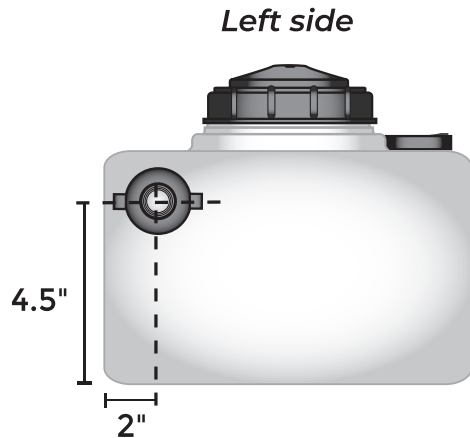
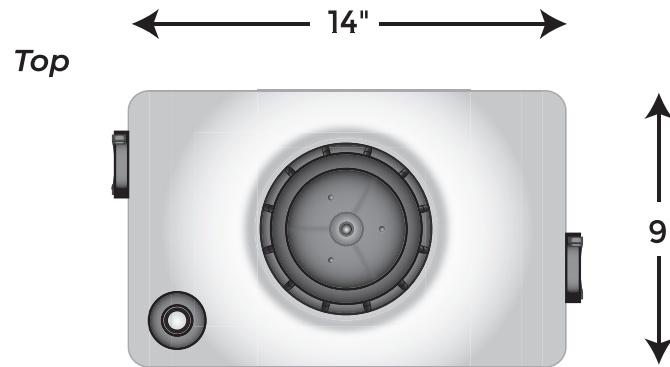

NB-2 Included Parts	
(2)	3/4" Bulkhead Fittings
(1)	1/2" Bulkhead Fittings

Part No.	MBH	GPH	Material	Pellets	Inlet/Outlet
2000	2,000	16	Poly	16 lbs.	3/4" Port

Endura (EDR) Condensing Hydronic Boilers

Provided the boiler is installed, commissioned, controlled, operated, and maintained in accordance with the Installation, Operation and Maintenance Manual, Fulton Heating Solutions ("Fulton") provides the following limited warranty:

LIFETIME THERMAL SHOCK WARRANTY

The pressure vessel is warranted for the lifetime of the boiler against defects in materials and/or workmanship that result in leakage determined by Fulton to have been caused by thermal shock (defined as abrupt, rapid heating and/or cooling). If so determined, Fulton will repair, or replace, exchange or credit, at its sole discretion, the pressure vessel, FOB factory.

TEN (10) YEAR PRESSURE VESSEL WARRANTY

The pressure vessel is warranted for ten (10) years from the date of shipment from the factory against failures determined by Fulton to be the result of defective materials, workmanship, or heat exchanger fireside flue gas condensate corrosion. If so determined, Fulton will repair, replace, exchange or credit, at its sole discretion, the pressure vessel, FOB factory. Waterside corrosion or scaling is not covered. Fireside corrosion due to contaminated combustion air or fuel is not covered. Failures outside of the ASME pressure vessel boundary are not covered.

FIVE (5) YEAR BURNER HEAD WARRANTY

The burner head is warranted for five (5) years from the date of shipment from the factory against failures determined by Fulton to be the result of defective materials or workmanship. If so determined, Fulton will repair or replace, at its sole discretion, FOB factory. This warranty does not cover damage due to wear and tear, misuse, or contaminated combustion air. This warranty does not cover other parts associated with the burner region such as gaskets, o-rings, pre-mix delivery components, and hardware.

TWO (2) YEAR PARTS WARRANTY

Other boiler parts are warranted against workmanship or material defects for two (2) years from shipment from the factory. Fulton will repair or replace, at its sole discretion, FOB factory. Defective parts must be returned to Fulton for evaluation and warranty credit consideration in accordance with the Returned Materials Authorization policy. This warranty does not cover loose ancillary equipment and accessories shipped with the boiler such as communication gateways, lead-lag sequencing control devices, regulators, pumps, or motorized isolation valves. This warranty does not cover consumables or wear items such as gaskets, o-rings, pressure relief valves, fuses, oxygen sensors, electrodes or filters.

CONDITIONS OF WARRANTY

The warranty is valid for the original installation and original owner only. The boiler must be installed, commissioned, controlled, operated, and maintained in accordance with the *Installation, Operation and Maintenance Manual*. There shall be no modifications, adjustments, or repairs to the equipment not authorized by Fulton in writing. There shall be no replacement parts used not manufactured or authorized by Fulton in writing.

Fulton shall be notified in writing as soon as any defect or failure becomes apparent. Failure to do so may limit Fulton's obligations under this warranty or render the warranty invalid in whole or in part. No agent or representative of Fulton other than the Warranty Manager or an officer of the company has authority to modify or alter the conditions of warranty. A formal Purchase Order is required prior to shipment of any replacement warranty item. This warranty does not include freight, handling or labor charges.

To the extent not prohibited by law in the state, province, jurisdiction or country of purchase, this warranty and the remedies set forth are exclusive and in lieu of all other warranties, remedies and conditions, whether oral, written, statutory, express or implied, including but not limited to, the implied warranties of merchantability and fitness for a particular purpose. In no event or under any circumstances shall Fulton be liable for any consequential, incidental, special, punitive or other indirect damages arising in any way including, but not limited to, loss of profits or business, even if Fulton has been advised of the possibility of such damages. Under no circumstances shall Fulton's liability exceed the amount paid to Fulton for the original equipment.

THIS LIMITED WARRANTY IS GOVERNED BY AND CONSTRUED UNDER THE LAWS OF THE STATE, COUNTRY, JURISDICTION, OR PROVINCE IN WHICH THE PRODUCT WAS ORIGINALLY PURCHASED. THE LIMITED WARRANTY TERMS CONTAINED IN THIS STATEMENT, EXCEPT TO THE EXTENT LAWFULLY PERMITTED, DO NOT EXCLUDE, RESTRICT, OR MODIFY BUT ARE IN ADDITION TO THE MANDATORY STATUTORY RIGHTS APPLICABLE TO THE SALE OF THIS PRODUCT TO THE PURCHASER. OUTSIDE THE UNITED STATES AND CANADA AND TO THE EXTENT SUCH WARRANTIES, TERMS AND CONDITIONS CANNOT BE DISCLAIMED AND ARE PERMITTED BY APPLICABLE LAW, FULTON LIMITS THE DURATION AND REMEDIES OF SUCH WARRANTIES AND CONDITIONS TO EIGHTEEN (18) MONTHS OF SHIPMENT FROM THE FACTORY OR TWELVE (12) MONTHS FROM STARTUP, WHICHEVER COMES FIRST. THIS LIMITED WARRANTY GIVES THE PURCHASER SPECIFIC LEGAL RIGHTS, AND THE PURCHASER MAY HAVE OTHER LEGAL RIGHTS, WHICH MAY VARY BY STATE, COUNTRY, JURISDICTION, OR PROVINCE.