

1 HVAC FLOOR PLAN
M1.0 1/4" = 1'-0"

- KEY NOTES:**
- REMOTE SMOKE DETECTOR TEST STATIONS FOR RTU-1, 2, & 3. TEST STATIONS TO BE MOUNTED ON THE MANAGERS OFFICE WALL. SECURITY CONTRACTOR SHALL WIRE RTU FACTORY MOUNTED SMOKE DETECTORS TO SECURITY/FIRE ALARM PANEL. MECHANICAL CONTRACTOR SHALL PROVIDE TEST STATION AND WIRING BETWEEN COMPONENTS AS WELL AS WIRING TO SHUT DOWN THE A/C FAN UPON ACTIVATION OF THE SMOKE DETECTOR. G.C. TO TEST THE SMOKE DETECTOR FUNCTIONS WITH THE WAWA PROJECT MANAGER.
 - WALL MOUNTED SENSOR(S) FOR EACH MECHANICAL UNIT PER ROOFTOP UNIT SCHEDULE ON SHEET M3.0. G.C. SHALL INSTALL AND WIRE TO UNIT. BAS CONTRACTOR SHALL CONNECT TO MECHANICAL UNIT ONLY.
 - COORDINATE EXACT LOCATION OF EXHAUST FAN PENETRATION WITH ARCHITECTURAL ROOF PLAN. INSTALL GALVANIZED DUCT WORK DOWN FROM FAN, INTO CEILING/JOIST SPACE, AND CONNECT TO CEILING GRILLES.
 - REFER TO TYPICAL DUCT PLENUM DETAIL ON SHEET M3.0.
 - COORDINATE DUCT WITH STRUCTURE IN THIS LOCATION. COORDINATE TAKEOFF LOCATIONS WITH ANGLED WEB MEMBERS.
 - PROVIDE SURFACE MOUNT ADAPTER FRAME TO ALLOW ACCESS TO CEILING ABOVE THROUGH DIFFUSER OPENING. SEE AIR DEVICE SCHEDULE.
 - ROUTE DUCT UNDER STRUCTURAL MEMBERS AT THIS LOCATION.
 - DUCTWORK TO RUN WITHIN JOIST SPACING. MECHANICAL CONTRACTOR TO COORDINATE MECHANICAL WORK WITH ALL TRADES PRIOR TO INSTALLATION.
 - DUCT TAKEOFF WITH DAMPER FROM BOTTOM OF MAIN DUCT.
 - TRANSFER DUCT ASSEMBLY.
 - PROVIDE SEALED 20"x20" PLENUM BOX ASSEMBLY ABOVE TRANSFER GRILLES TO ALLOW FLEX TRANSFER DUCT CONNECTIONS.
 - GRILLE OPEN TO ABOVE CEILING.
 - INSTALL EXHAUST FAN ABOVE CEILING PER DETAIL SHEET M3.0. FAN SHALL BE WIRED TO EMERGENCY SHUT-OFF SWITCH PROVIDED BY OTHERS. REFERENCE ARCHITECTURAL AND ELECTRICAL DRAWINGS.
 - MOUNT CENTER OF EXHAUST GRILLE AT 12" ABOVE FINISHED FLOOR. ROUTE DUCT SIZES AS SHOWN FROM GRILLE UP IN WALL CAVITY TO ABOVE CEILING, THEN TO EXHAUST FAN AND OUT TO EXTERIOR WALL LOUVER. COORDINATE DUCT ROUTING WITH ALL OTHER TRADES.
 - 12"x12" EXTERIOR WALL LOUVER MODEL EHH-601D AS MANUFACTURED BY GREENHECK. INSTALL PER MANUFACTURER'S RECOMMENDED INSTALLATION INSTRUCTIONS. FLORIDA PRODUCT APPROVAL #10088-1. PROVIDE WITH BIRD SCREEN, 1-1/2" FLANGE, AND ALUMINUM MULL FINISH.
 - EMERGENCY SHUT-OFF SWITCH AND WALL PLACARD INDICATING VENTILATION SYSTEM EMERGENCY SHUT-OFF PROVIDED BY OTHERS REFERENCE ELECTRICAL AND ARCHITECTURAL DRAWINGS.

SHEET GENERAL NOTE:

A. MECHANICAL CONTRACTOR SHALL ADJUST ALL LINEAR SLOT DIFFUSERS TO A GENERALLY VERTICAL FLOW. ADJUSTMENT SHALL BE MADE SO AS TO AVOID AIRFLOWS ON SENSORS, REFRIGERATION CASES, OR OPEN FOOD REFRIGERATION EQUIPMENT.

HVAC LEGEND	
SYMBOL	DESCRIPTION
	NEW RECTANGULAR OR ROUND DUCT
	FLEXIBLE DUCT
	SUPPLY AIR DUCTWORK UP THROUGH PLAN
	RETURN AIR DUCTWORK UP THROUGH PLAN
	EXHAUST AIR DUCTWORK UP THROUGH PLAN
	90° ELBOW WITH TURNING VANES
	MANUAL AIR VOLUME CONTROL DAMPER
	4 WAY SUPPLY DIFFUSER
	3 WAY SUPPLY DIFFUSER
	2 WAY OPPOSED SUPPLY DIFFUSER
	2 WAY CORNER SUPPLY DIFFUSER
	RETURN AIR DEVICE
	EXHAUST AIR DEVICE
	AIR CURTAIN
	LINEAR SLOT DIFFUSER WITH PLENUM
	COMBINATION TEMPERATURE/HUMIDITY SENSOR
	TEMPERATURE SENSOR
	CO2 SENSOR
	SWITCH
	TYPE MARK
	MECHANICAL EQUIPMENT TAG
	CONDENSATE PIPING
	ROOF MOUNTED EXHAUST FAN
	INLINE EXHAUST FAN
	PACKAGED ROOFTOP AIR CONDITIONER

2600 Malland Center Parkway
Suite #200
Maitland, FL 32751
P (407) 661-9100
F (407) 661-9101
c-p.com

CUHACI PETERSON

Copyright © All rights reserved. No part of this document may be reproduced without the prior written permission of the copyright owner. Any use or reproduction of this document without written permission from C.P. is a violation of Federal copyright laws.

CLIENT NAME
WAWA
260 WEST BALTIMORE PIKE
WAWA, PENNSYLVANIA 19063

PROJECT NAME
WAWA F85FB V2021.3
STORE #5453
US 301 & SE 32ND ST
OCALA, FL

No.	Description	Date
1	PRE-BID SET	06/27/2024
2	BID SET	07/19/2024
3	CONSTRUCTION SET	10/09/2024

PROJECT NO.
2023034
DATE
11-16-2023
DRAWN
JSP
CHECKED
ESD

M1.0

HVAC FLOOR PLAN

BUILDING LOCATION	WIND SPEED ZONE (FBC FIGURE 1609A)
OCALA, FL	130 MPH

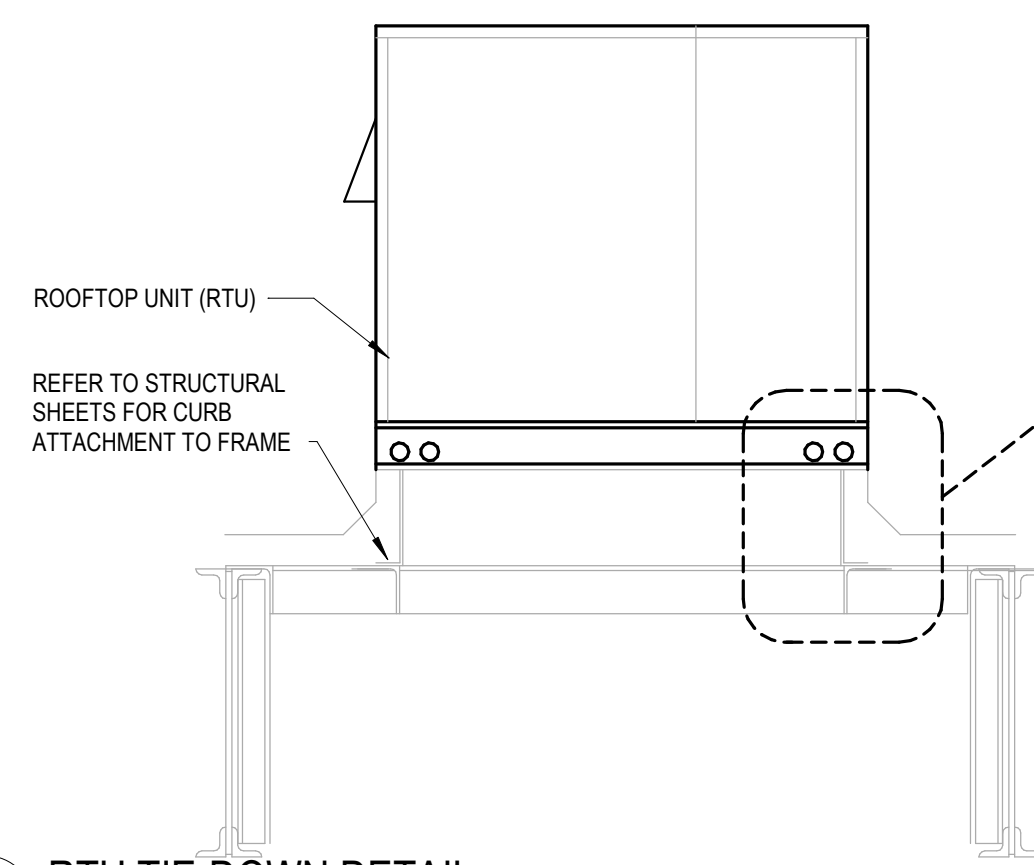

1 RTU TIE-DOWN DETAIL
M3.0 NOT TO SCALE

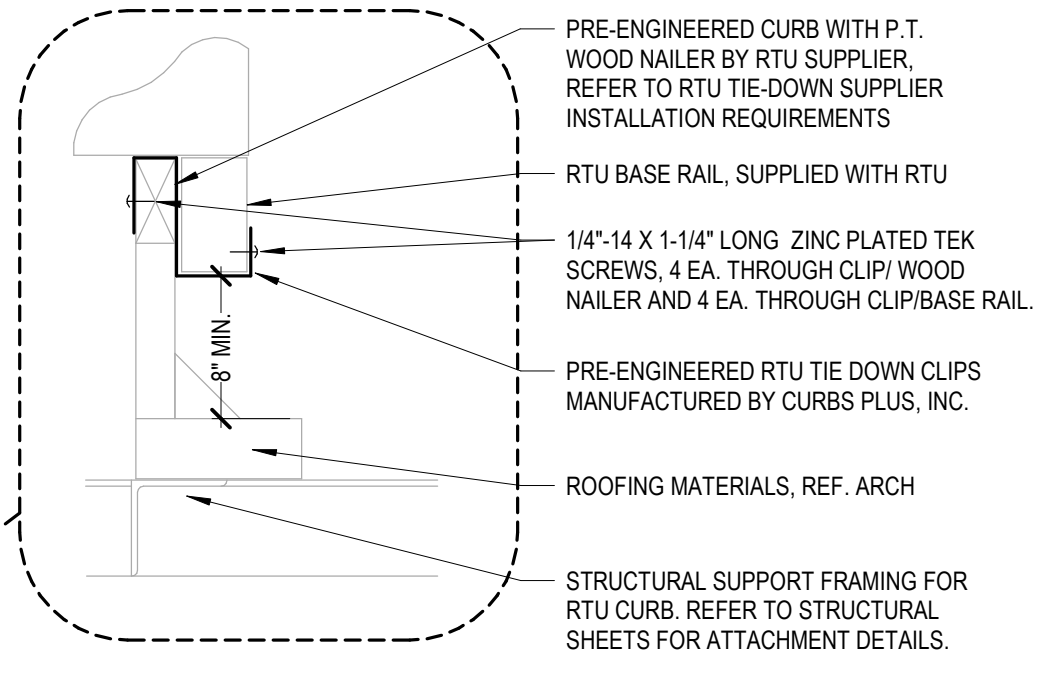

2 CEILING DIFFUSER RUNOUT DETAIL
M3.0 NOT TO SCALE

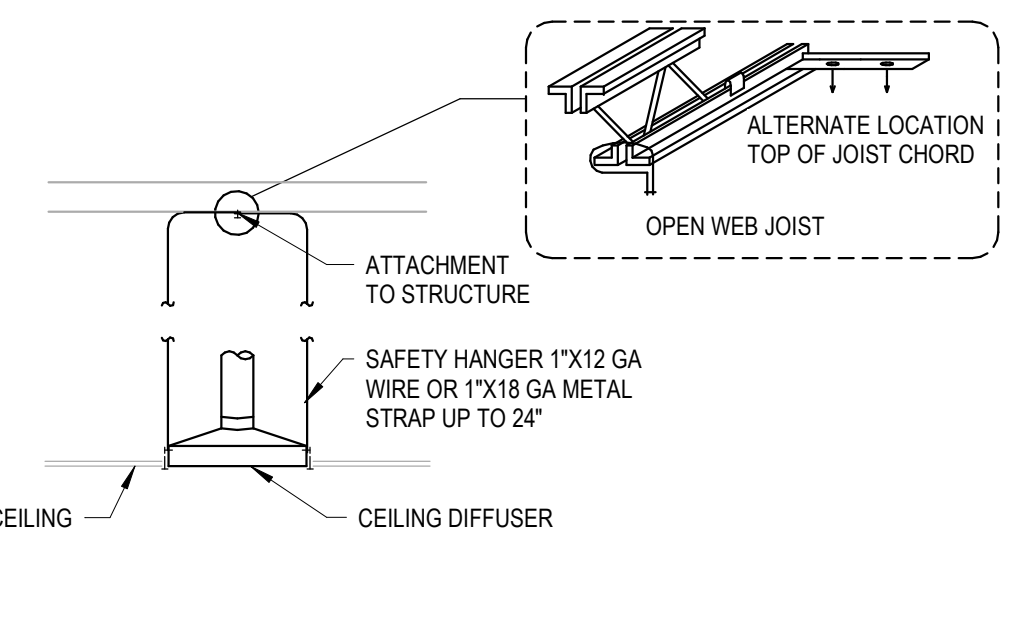

3 CEILING MOUNTED AIR DIFFUSER SUPPORT DETAIL
M3.0 NOT TO SCALE

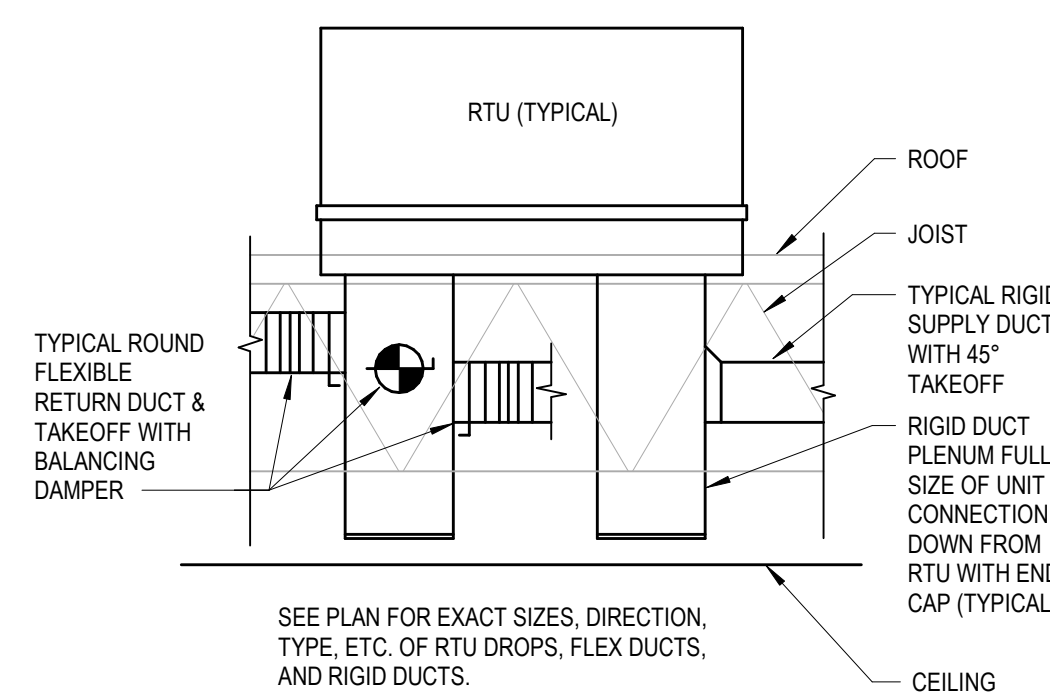

4 TYPICAL DUCT PLENUM DETAIL
M3.0 NOT TO SCALE

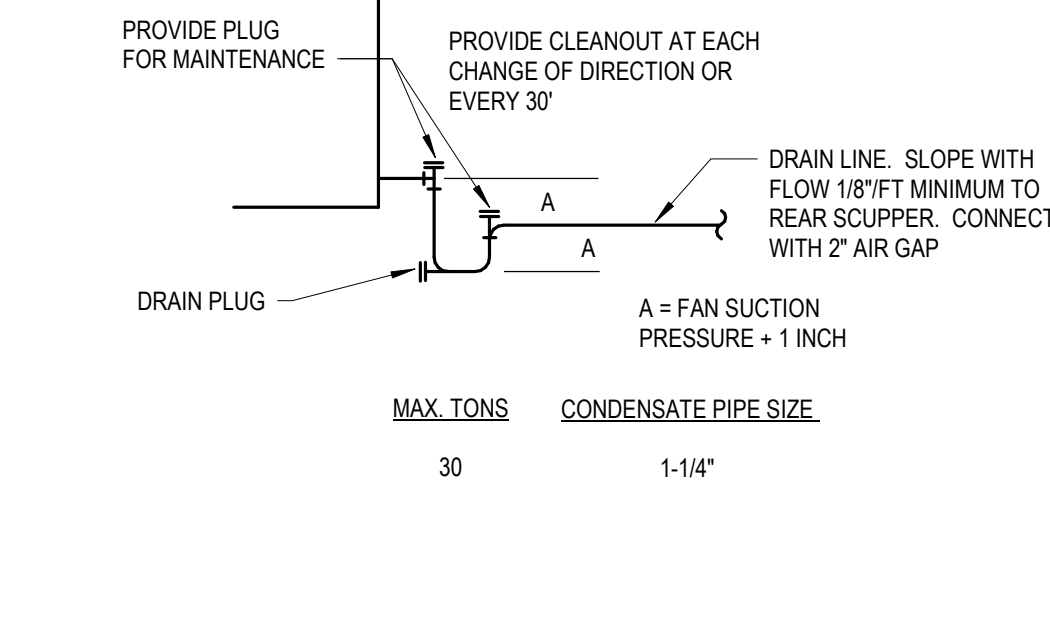

5 CONDENSATE DRAIN TRAP DETAIL
M3.0 NOT TO SCALE

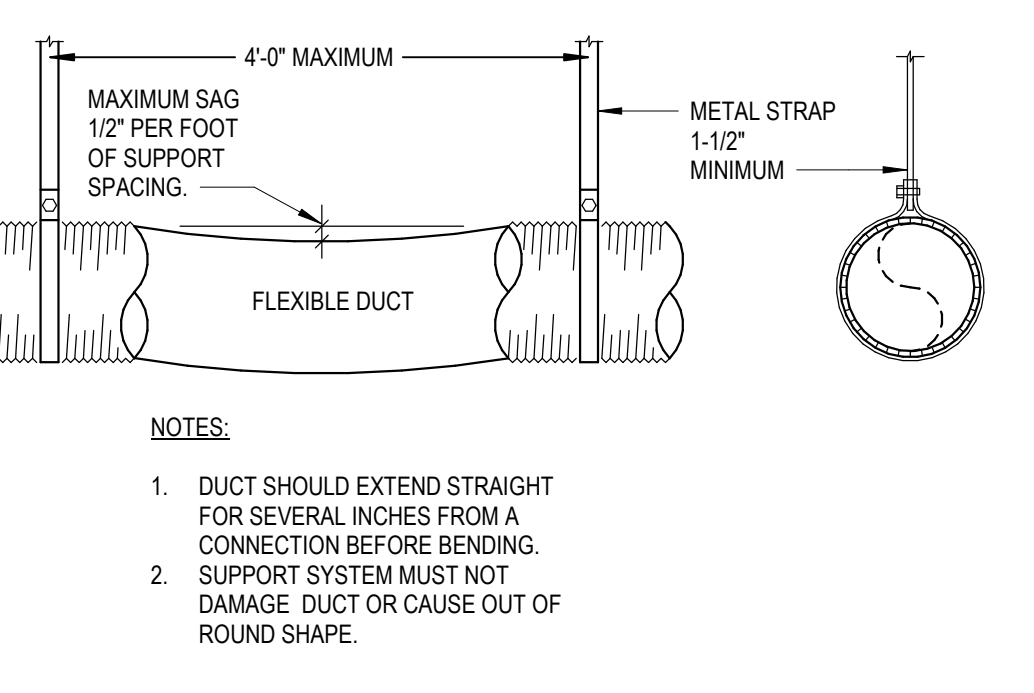

6 FLEX DUCT SUPPORT DETAIL
M3.0 NOT TO SCALE

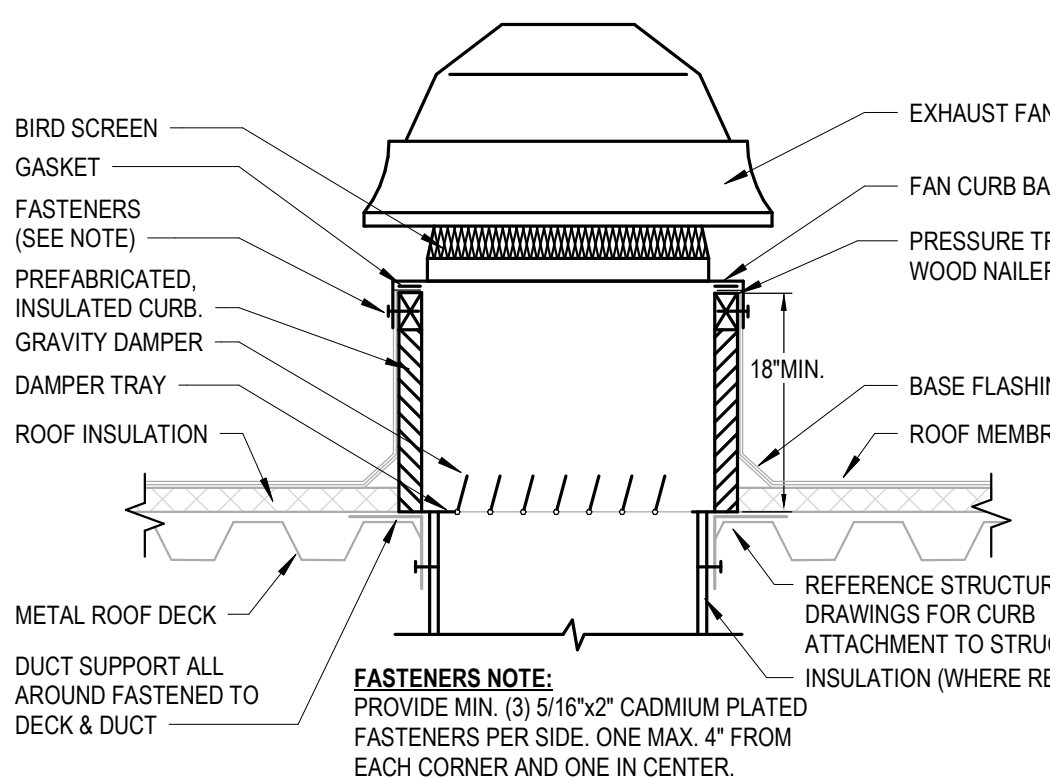

7 ROOF FAN MOUNTING DETAIL
M3.0 NOT TO SCALE

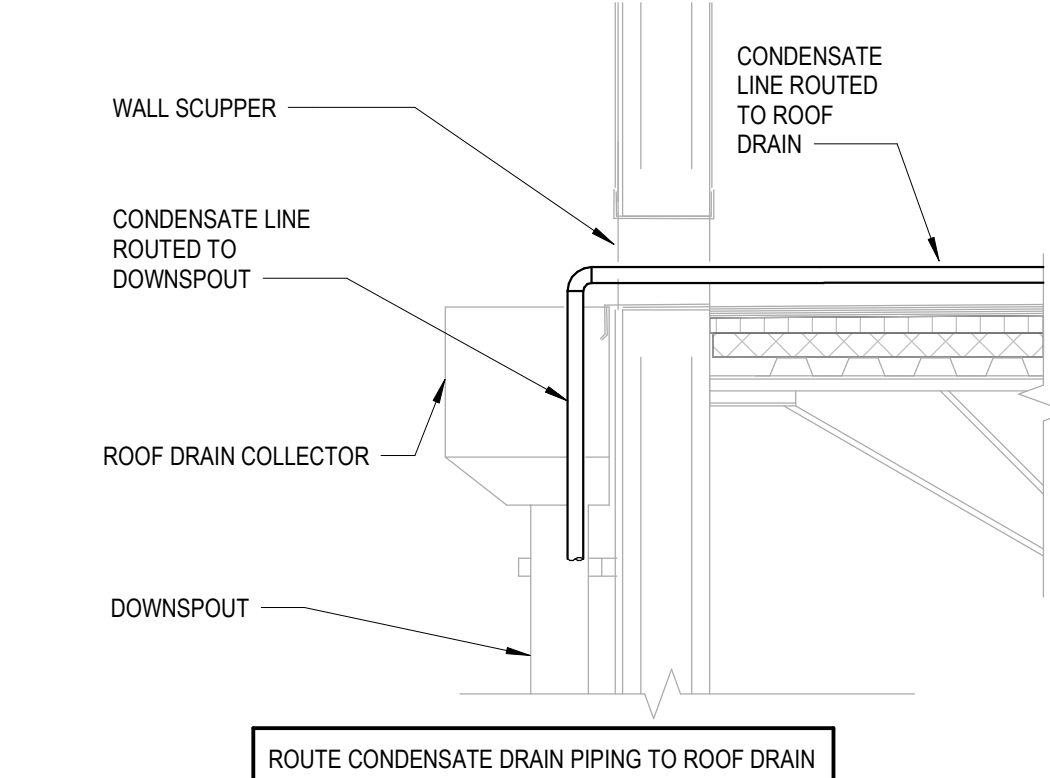

8 CONDENSATION TERMINATION DETAIL
M3.0 NOT TO SCALE

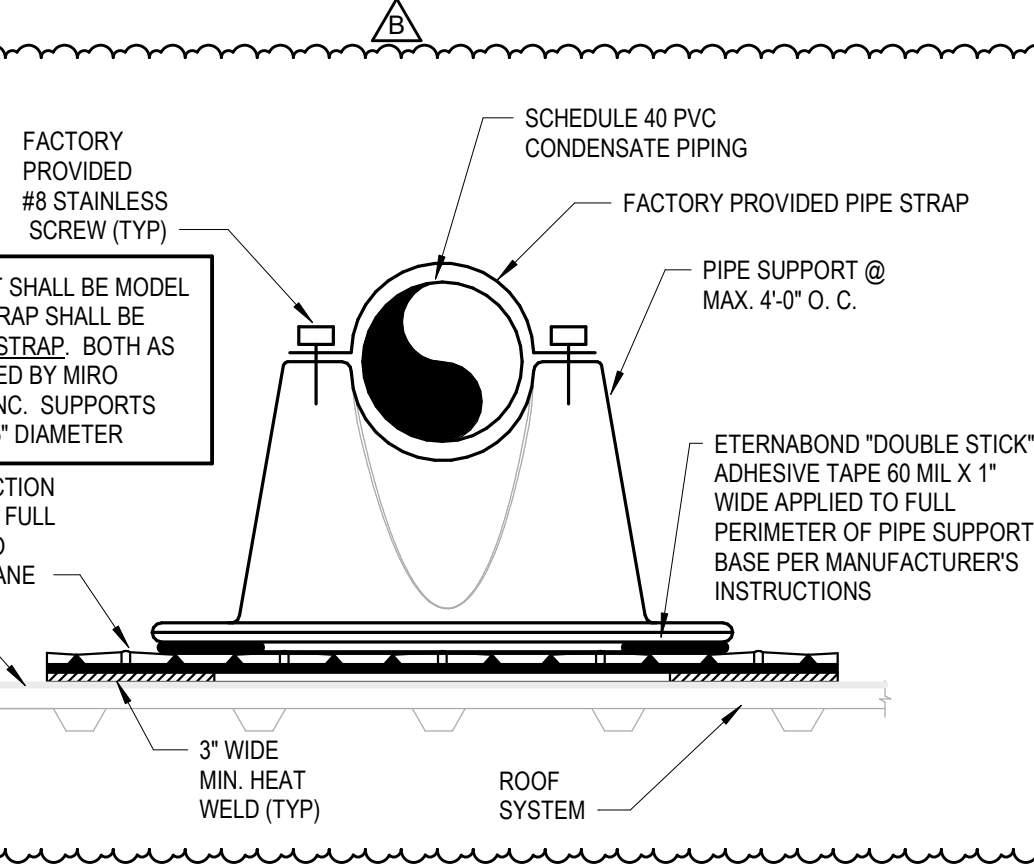

9 CONDENSATE PIPE ROOF SUPPORT DETAIL
M3.0 NOT TO SCALE

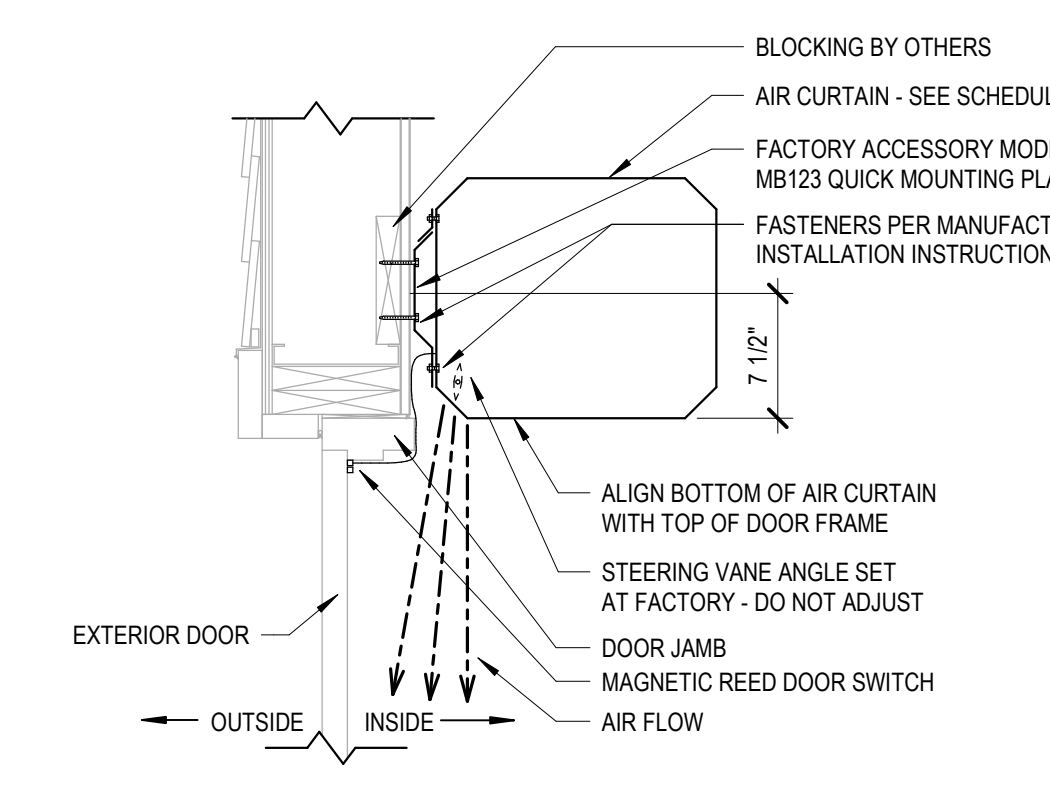

10 AIR CURTAIN INSTALLATION DETAIL
M3.0 NOT TO SCALE

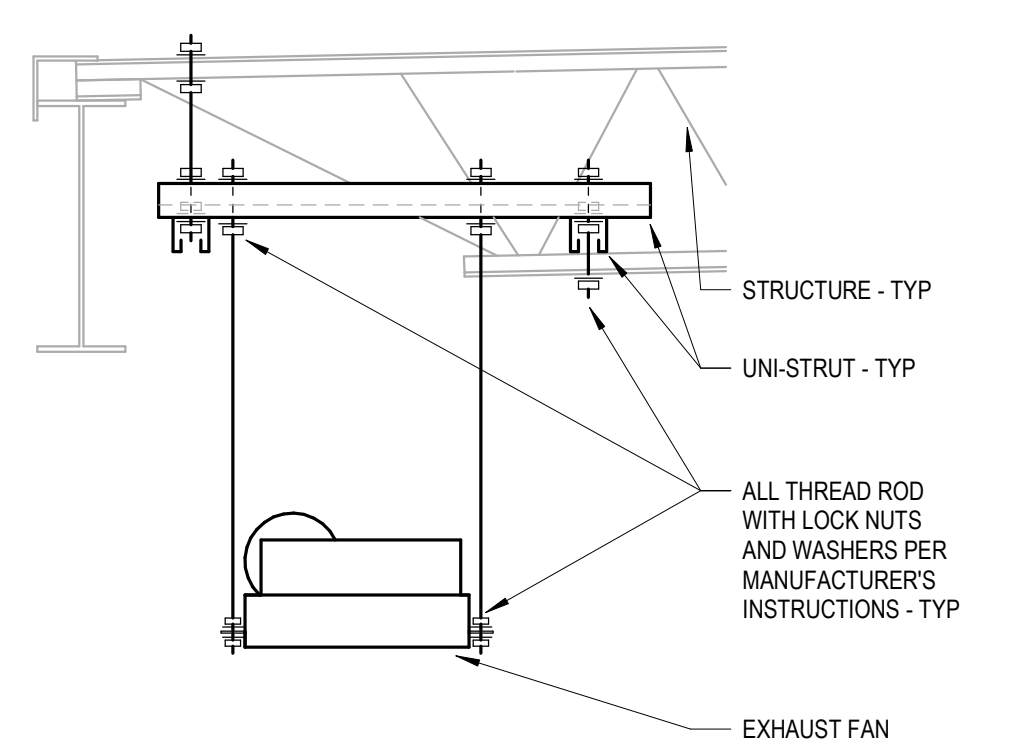

11 INLINE FAN MOUNTING DETAIL
M3.0 NOT TO SCALE

HVAC GENERAL NOTES

- ALL MECHANICAL WORK SHALL BE IN STRICT ACCORDANCE WITH THE 2020 FLORIDA BUILDING CODE - MECHANICAL, SMACNA, UL, LOCAL CODES, MANUFACTURER'S RECOMMENDATIONS, AND ALL AUTHORITIES HAVING JURISDICTION.
- CONTRACTOR TO VISIT SITE AND VERIFY ALL CLEARANCES BEFORE FABRICATION OF DUCTWORK AND PROVIDE ADDITIONAL OFFSET AND/OR CHANGES IN DUCT SIZES TO MEET FIELD CONDITIONS AND COORDINATE WITH ELECTRICAL, PLUMBING AND FIRE PROTECTION SUBCONTRACTOR BEFORE ANY CONSTRUCTION WORK.
- SUPPLY AIR, RETURN AIR, OUTSIDE AIR AND EXHAUST AIR DUCTWORK SHALL BE SHEET METAL CONSTRUCTION. DUCT SHALL BE INSTALLED SECURELY SUPPORTED, HUNG OR SUSPENDED FROM THE STRUCTURE. JOINTS SHALL BE SEALED WITH 3\"/>
- OUTSIDE AIR INTAKES (ROOFTOP UNITS, GRAVITY ROOF VENTS, LOUVERS) SHALL MAINTAIN A MINIMUM OF 10\"/>
- PROVIDE ALL MECHANICAL EQUIPMENT WITH MANUFACTURER'S RECOMMENDED SERVICE AREA CLEARANCES.
- ALL ROOFTOP UNITS SHALL BE CONSTRUCTED AND INSTALLED TO WITHSTAND LOCAL WIND LOAD DESIGN.
- SMOKE DETECTORS SHALL BE FINISHED AND INSTALLED IN RTU BY THE UNIT MANUFACTURER. WIRE TO THE KEY SWITCH BY THE MECHANICAL CONTRACTOR, AND WIRE TO THE FIRE ALARM BY THE FIRE ALARM CONTRACTOR. SMOKE DETECTORS SHALL BE INSTALLED IN ACCORDANCE WITH NFPA 72, NATIONAL FIRE ALARM CODE, NFPA 98A, STANDARD FOR INSTALLATION OF FIRE-CONDITIONING AND VENTILATING SYSTEMS, THE 2020 FLORIDA BUILDING CODE - MECHANICAL, AND THE MANUFACTURER'S INSTALLATION INSTRUCTIONS. PROVIDE A VISIBLE/AUDIBLE NOTIFICATION PANEL. MAKE SYSTEM SENSOR 58K4I ON EQUAL, COMPATIBLE WITH BUILDING FIRE ALARM SYSTEM.
- PLANS AND DIAGRAMS ARE SCHEMATIC ONLY AND SHOULD NOT BE SCALED.
- HVAC CONTRACTOR IS RESPONSIBLE FOR ANY ADDED ELECTRICAL COSTS WHICH MAY RESULT FROM SUBSTITUTED EQUIPMENT.
- PROVIDE EXTERNAL DUCT INSULATION FOR SUPPLY, RETURN AND OUTSIDE AIR DUCTWORK. DUCTWORK INSULATION SHALL BE FOIL FACED FIBERGLASS DUCT WRAP WITH A MINIMUM THERMAL RESISTANCE (R) OF 6.0. INSULATION SHALL HAVE VAPOR BARRIER. INSTALL PER MFR. REQUIREMENTS.
- COORDINATE CEILING MOUNTED DIFFUSERS, REGISTERS, AND GRILLES AND OTHER CEILING MOUNTED EQUIPMENT WITH LIGHTING FIXTURES.
- TURNING VANES SHALL BE PROVIDED IN ALL SUPPLY DUCT RECTANGULAR ELBOWS WITH ANGLES BETWEEN 15 DEGREES AND LESS THAN 90 DEGREES PER THE SMACNA HVAC DUCT CONSTRUCTION STANDARDS MANUAL.
- DUCT DIMENSIONS SHOWN ON DRAWINGS ARE CLEAR INSIDE DIMENSIONS. ALL DIMENSIONS ARE IN INCHES UNLESS OTHERWISE NOTED.
- DUCTWORK, DIFFUSERS, REGISTERS, GRILLES, AND OTHER ITEMS OF THE AIR HANDLING SYSTEM SHALL NOT BE SUPPORTED BY THE CEILING OR CEILING SUSPENSION SYSTEM.
- UNLESS OTHERWISE NOTED, INSTALL DUCTWORK AS HIGH AS POSSIBLE, TIGHT TO BOTTOM OF STRUCTURE. COORDINATE DUCT ELEVATION WITH STORM LEADERS, WATER PIPING, SANITARY DRAINS AND MAJOR ELECTRICAL CONDUITS.
- CONTRACTOR TO PROVIDE ALL SUPPLEMENTARY STEEL REQUIRED TO SUPPORT MECHANICAL EQUIPMENT & MATERIALS. INSTALLATION OF EQUIPMENT SHALL COMPLY WITH MANUFACTURER'S SPECIFICATIONS AND CLEARANCE REQUIREMENTS FOR SERVICING OF EQUIPMENT.
- VERIFY VOLTAGE WITH ELECTRICAL CONTRACTOR BEFORE ORDERING EQUIPMENT.
- PROVIDE A TRAP IN ALL CONDENSATE PIPING SERVING AIR HANDLING UNITS AND ROOFTOP UNITS. SLOPE CONDENSATE LINE 1/8\"/>
- GUARANTEE, FOR ONE YEAR AFTER DATE OF ACCEPTANCE BY THE OWNER, ALL EQUIPMENT, MATERIALS AND WORKMANSHIP TO BE FREE FROM DEFECT.
- DO NOT CUT STRUCTURAL MEMBERS WITHOUT PRIOR WRITTEN APPROVAL OF THE STRUCTURAL ENGINEER.
- FLEXIBLE AND RIGID ROUND DUCT TAKE-OFFS FOR DIFFUSERS SHALL BE THE SAME SIZE AS DIFFUSER NECK. MAXIMUM FLEXIBLE DUCT LENGTH SHALL BE 5'0\"/>
- CLASS 1, UL181 LISTED AND COMPLY WITH NFPA 98A AND NFPA 90B.
- ALL WALL MOUNTED TEMPERATURE, HUMIDITY, AND CO2 SENSORS SHALL BE INSTALLED AT AN ELEVATION OF 5'4\"/>
- TRACES FOR A NEAT APPEARANCE. FINAL LOCATION OF SENSORS SHALL BE SUBJECT TO THE APPROVAL OF THE OWNER OR THEIR REPRESENTATIVE IN THE FIELD.
- PROVIDE FLEXIBLE NEOPRENE DUCT CONNECTORS ON THE DISCHARGE AND ENTERING SIDES OF PACKAGED ROOFTOP UNITS, FANS, AND OTHER VIBRATING EQUIPMENT TO WHICH DUCTWORK IS ATTACHED.
- THE GENERAL CONTRACTOR IS RESPONSIBLE FOR ALL TRADES INSTALLATION SCHEDULES. COORDINATE WORK SCHEDULE WITH GENERAL CONTRACTOR.
- REFER TO ARCHITECTURAL DRAWINGS FOR ALL RELATED CONSTRUCTION DETAILS AS APPLICABLE TO THE HVAC SYSTEM. CHANGE AND WALL PENETRATIONS INTENDED FOR DUCTWORK AND PIPING SHALL BE VERIFIED WITH ARCHITECTURAL DRAWINGS PRIOR TO INSTALLATION.
- MECHANICAL EQUIPMENT, DUCTWORK AND PIPING IS SHOWN AT APPROXIMATE LOCATIONS. FIELD MEASURE FINAL DUCTWORK AND PIPING LOCATIONS PRIOR TO FABRICATION AND MAKE ADJUSTMENTS AS REQUIRED TO FIT THE DUCTWORK AND PIPING WITHIN THE AVAILABLE SPACE. FIELD VERIFY FINAL LOCATIONS TO INSTALL EQUIPMENT IN ACCORDANCE WITH THE MANUFACTURER'S RECOMMENDATIONS REGARDING SERVICE CLEARANCE AND PROPER AIRFLOW CLEARANCE AROUND EQUIPMENT.
- WHEN THE INTENT OF THE DRAWINGS AND SPECIFICATIONS IS NOT CLEAR, OR IS CAPABLE OF MORE THAN ONE INTERPRETATION, SUCH MATTERS WILL BE BROUGHT TO THE ATTENTION OF THE ARCHITECT/ENGINEER IN WRITING BEFORE THE SUBMISSION OF BIDS. THE CONTRACTOR SHALL THOROUGHLY ACQUAINT HIMSELF WITH THE MECHANICAL, ARCHITECTURAL, STRUCTURAL, AND ELECTRICAL PLANS BEFORE SUBMITTING HIS FINAL BID. NO ADDITIONAL COMPENSATION WILL BE ALLOWED DUE TO THE CONTRACTOR'S FAILURE TO FAMILIARIZE HIMSELF WITH THE PLANS.
- CONTRACTOR TO ALLOW SUFFICIENT TIME (APPROXIMATELY 2 WEEKS) FOR EQUIPMENT REVIEW. CONTRACTOR SHALL SUBMIT THE FOLLOWING EQUIPMENT FOR REVIEW (1 HARD COPY) PRIOR TO ORDERING AND INSTALLATION: ROOFTOP UNITS, AIR HANDLING UNITS AND AIR COOLED CONDENSERS, DIFFUSERS AND REGISTERS, EXHAUST FANS AND MAKE UP AIR FANS, DUCT INSULATION, DUCT CONSTRUCTION STANDARDS.
- AFTER THE HEATING AND AIR CONDITIONING SYSTEM INSTALLATIONS ARE COMPLETE, THE CONTRACTOR SHALL HAVE EACH SYSTEM TESTED, ADJUSTED, AND BALANCED BY AN INDEPENDENT TESTING AND BALANCING CONTRACTOR. SEE SPECIFICATIONS FOR TESTING AND BALANCING CONTRACTOR CERTIFICATIONS AND REQUIREMENTS. UPON COMPLETION OF TEST AND BALANCE OF ALL SYSTEMS, THE CONTRACTOR SHALL PREPARE THE OWNER AND ARCHITECT WITH A WRITTEN TEST AND BALANCE REPORT IN A TIMELY MANNER PER SPECIFICATIONS.

HVAC ROOFTOP UNIT SCHEDULE

MARK	AREA SERVED	SUPPLY AIR FAN DATA				ELECTRIC HEAT		UNIT POWER		WEIGHT (LBS)	COOLING CAPACITY		BASIS OF DESIGN										
		SUPPLY AIR CFM	OUTSIDE AIR (IN)	E.S.P. (IN)	HP	KW	CONTROL STAGES	VOLTAGE	PHASE		MCA	MOCP	TOTAL COOLING MBH	SENSIBLE COOLING MBH	EWB (F)	EDB (F)	AMBIENT (F)	EER	MANUFACTURER	MODEL	NOTES		
RTU-1	RETAIL	8.5	3400	500	0.5	3.75	22.5	1	208 V	3	70	70	1357	98.1	75.4	76.5	63.9	95/79	12.3	15.7	LENNOX ENLIGHT	LCT102H4E	1-20
RTU-2	FOOD SERVICE	12.5	5000	500	0.5	3.75	N/A	N/A	208 V	3	64	80	1342	146.1	136	75.2	62.5	95/79	11.0	14.6	LENNOX ENLIGHT	LCT150H4E	2-20
RTU-3	RETAIL	7.5	3000	500	0.5	3.75	22.5	1	208 V	3	70	70	1350	91.8	68.7	76.1	63.5	95/79	12.5	15.7	LENNOX ENLIGHT	LCT092H4E	2-20

- NOTES:
- PROVIDE CO2 SENSOR FOR INTERLINK WITH BUILDING AUTOMATION SYSTEM.
 - PROVIDE LENNOX HUMIDITROL HOT GAS REHEAT OPTION.
 - PROVIDE REMOTE WALL MOUNTED COMBINATION TEMPERATURE/HUMIDITY SENSOR MODEL 21W06
 - REFER TO CONTROL SYSTEM NOTES FOR CONTROL COMPONENTS REQUIREMENTS.
 - PROVIDE 5MINUTE ANTI-SHORT CYCLE TIMER.
 - PROVIDE THRU THE BASE ELECTRICAL AND SINGLE POINT CONNECTION.
 - PROVIDE WITH FACTORY 2\"/>
 - PROVIDE WITH 18\"/>
 - PROVIDE FACTORY 15 AMP GFCI SERVICE OUTLET WITH WEATHER-PROOF COVER. COORDINATE WITH ELECTRICAL CONTRACTOR TO PROVIDE FIELD WIRING TO RECEPTACLE.
 - PROVIDE WITH FACTORY INSTALLED DISCONNECT.
 - PROVIDE WITH MOTORIZED DAMPER AND OUTSIDE AIR INTAKE HOOD.
 - PROVIDE MANUFACTURER'S MOTOR AND DRIVE PACKAGE AS REQUIRED TO MEET SCHEDULED AIR CAPACITIES AND PRESSURE DROP.
 - PROVIDE FACTORY APPLIED PHENOLIC COATING FOR CORROSION PROTECTION ON CONDENSER COILS AND CONDENSATOR COIL IN 24\"/>
 - PROVIDE BUILDING AUTOMATION SYSTEM (BAS) EQUIPMENT - REFER TO BAS SYSTEM MASTER SPEC FOR SYSTEM DETAIL AND EQUIPMENT PART NUMBERS.
 - PROVIDE FACTORY INSTALLED BACNET BAS INTERFACE.
 - PROVIDE LENNOX DIRTY FILTER SWITCH.
 - PROVIDE LENNOX ICM CONTROL BOARD (STANDARD ON L-SERIES UNITS).
 - TEMPERATURE SETPOINT: 74°F COOLING, 68°F HEATING, HUMIDITY SETPOINT: 50% RELATIVE HUMIDITY.
 - PROVIDE WITH FACTORY CONDENSATE PAN WATER LEVEL MONITORING DEVICE FOR COMPLIANCE WITH FBC 2020 MECHANICAL SECTION 307.2.3.
 - PROVIDE WITH FACTORY INSTALLED SUPPLY AND RETURN SMOKE DETECTORS.

OUTSIDE AIR CALCULATION

AREA SERVED	AREA (SQFT)	PEOPLE / 1000 SQFT	# PEOPLE	CFM / PERSON	PEOPLE O.A. RECD (CFM)	CFM / SQFT	SQFT OUTSIDE AIR (CFM)	TOTAL CFM CALCULATED	CFM SUPPLIED
OFFICE	70	5	2	5	10	0.06	5	15	
ASSOCIATE	100	5	2	5	10	0.06	6	16	
DELIVERY	78	2	1	10	10	0.12	10	20	
RETAIL	1904	15	29	7.5	218	0.12	229	447	500
RTU-1								498	
FOOD SVC. 1								316	
FOOD SVC. 2								258	
BACKROOM								140	
RTU-2								207	500
STAGING								116	
WASHROOM								174	
COFFEE								242	
RETAIL								559	
RTU-3								219	300

- NOTES:
- OCCUPANCY LOAD VENTILATION RATES ARE BASED ON NET OCCUPIABLE SPACE IN ACCORDANCE WITH THE 2020 FLORIDA MECHANICAL CODE, TABLE 403.3.1.1.
 - ANTICIPATED NUMBER OF PEOPLE IS BASED ON AN OCCUPANCY LOAD FACTOR (# PEOPLE/SF) VALUE (BASED ON THE 2020 FLORIDA MECHANICAL CODE, TABLE 403.3.1.1).

HVAC EXHAUST FAN SCHEDULE

MARK	CFM	EXT. STATIC PRESSURE	FAN TYPE	DRIVE TYPE	S.O.N.	HP	FAN RPM	VOLTAGE	PHASE	BASIS OF DESIGN		
										MANUFACTURER	MODEL	
EF-1	800 CFM	0.250 in-wg	DOWNBLAST	DIRECT	0.3	1/4	863	120 V	1	GREENECK	G-100	1,2
EF-2	60 CFM	0.125 in-wg	INLINE	DIRECT	0.3	21 WATTS	584	120 V	1	GREENECK	CSP-B110	3

- NOTES:
- NO SUBSTITUTIONS PERMITTED.
 - PROVIDE WITH FACTORY DISCONNECT, FACTORY WIRED SOLID STATE SPEED CONTROLLER, 18\"/>
 - WIRE FOR CONTINUOUS OPERATION.
 - PROVIDE WITH FACTORY DISCONNECT & FACTORY WIRED SOLID STATE SPEED CONTROLLER. FAN SHALL BE WIRED TO EMERGENCY SHUTOFF SWITCH PROVIDED BY OTHERS. REFERENCE ARCHITECTURAL AND ELECTRICAL DRAWINGS.

HVAC AIR DEVICE SCHEDULE

TYPE MARK	MANUFACTURER	MODEL	SERVICE	DESCRIPTION	MOUNTING TYPE	MATERIAL	NECK SIZE	FACE SIZE	NOTES
CD-1	PRICE	AMD	SUPPLY	LOUVERED FACE DIRECTIONAL DIFFUSER	LAY-IN	ALUMINUM	18\"/>		
CD-2	PRICE	AMD	SUPPLY	LOUVERED FACE DIRECTIONAL DIFFUSER	SURFACE	ALUMINUM	18\"/>		
CD-3	PRICE	AMD	SUPPLY	LOUVERED FACE DIRECTIONAL DIFFUSER	SURFACE	ALUMINUM	8\"/>		
G-1	PRICE	630FF	RETURN/EXHAUST	LOUVERED FACE FILTER RETURN GRILLE	LAY-IN	ALUMINUM	20\"/>		
G-2	PRICE	630FF	RETURN/TRANSFER	LOUVERED FACE FILTER RETURN GRILLE	SURFACE	ALUMINUM	16\"/>		
G-3	PRICE	630FF	RETURN/EXHAUST	LOUVERED FACE FILTER RETURN GRILLE	SURFACE	ALUMINUM	8\"/>		
G-4	PRICE	82F	TRANSFER	EGG GRATE FACE RETURN GRILLE	LAY-IN	ALUMINUM	22\"/>		
G-5	PRICE	630 D	EXHAUST	LOUVERED FACE EXHAUST GRILLE	SURFACE	ALUMINUM	8\"/>		
LD-1	PRICE	TBD4	SUPPLY	48\"/>					

- NOTES:
- NO SUBSTITUTIONS PERMITTED.
 - FOR LAY-IN CEILING PROVIDE WITH 18\"/>
 - ROUND NECK SIZE SHALL BE EQUAL TO FLEX SERVING DIFFUSER.
 - PROVIDE WITH PLENUM INTERNALLY LINED WITH COATED FIBERBOARD. EXTERNALLY INSULATE PLENUM UPON INSTALLATION WITH DUCT WRAP INSULATION.
 - LOUVERED FACE DIRECTIONAL DIFFUSERS: SURFACE ALUMINUM 8\"/>
 - "DR" STYLE (1/4 TURN FASTENERS ONLY) - OMIT HINGE. FILTER TYPE RETURN GRILLES PROVIDED SOLELY FOR MAINTENANCE PURPOSES. OMIT FILTER UPON INSTALLATION.
 - PROVIDE WITH TYPE 6 BEVELLED SURFACE MOUNT FRAME AND FACTORY SCHEDULE TO ROUND NECK ADAPTER MODEL "SR".
 - PROVIDE LAY-IN STYLE FACE DIFFUSER AND ALUMINUM PLASTER FRAME MODEL APF. COORDINATE LOCATION WITH CEILING FRAMING INSTALLER.
 - PROVIDE WITH FACTORY BACK PAN INSULATION.

HVAC AIR CURTAIN SCHEDULE

MARK	AREA SERVED	BASIS OF DESIGN		NOZZLE CFM	HP	VOLTAGE	PHASE	HEIGHT	NOTES
		MANUFACTURER	MODEL						
AC-1	STAGING	POWERED AIRE	BCE-148	2155 CFM	0.5	120 V	1	7'-2"	1-4
AC-2	DELIVERY VESTIBULE	POWERED AIRE	BCE-148	2155 CFM	0.5	120 V	1	7'-2"	1-4

- NOTES:
- NO SUBSTITUTIONS PERMITTED.
 - MOUNT INSIDE BUILDING ABOVE DOOR AT 7'-2" A.F.F. MOUNTING HEIGHT IS FROM BOTTOM OF AIR CURTAIN.
 - PROVIDE ALL NECESSARY MOUNTING BRACKETS AND ACCESSORIES.
 - PROVIDE WITH MODEL SA-300 COMMERCIAL MAGNETIC REED DOOR SWITCH.
 - AIR CURTAIN CONTROLLED BY MAGNETIC REED DOOR SWITCH; FAN ON WHEN DOOR IS OPEN.

LENNOX SETUP PARAMETERS - FLORIDA STORES (R2)

- UNIT ID CONFIGURATIONS (MECHANICAL CONTRACTOR TO DEFINE / AS APPLICABLE):
- BACNET CONFIGURATION: GO TO SETTINGS-GENERAL-CONFIGURATION D1 POSITION 5 SET TO "B"
 - NETWORK CONFIGURATION: GO TO SETUP-NETWORK INTEGRATION, SET TO BACNET
 - CONTROL MODE: SET CONTROL MODE TO ROOM SENSOR; CO2, TEMP & HUMIDITY (PER UNIT, AS NEEDED).

INDIVIDUAL PARAMETER CONFIGURATIONS (MECHANICAL CONTRACTOR TO DEFINE / AS APPLICABLE):

- PARAMETER 105 DEHUMID MODE: 7 NO CONDITIONS
- PARAMETER 106 DEHUMID SETPOINT: 50. THIS IS A CENTERED SET POINT (+/-)
- PARAMETER 107 DEHUMID DEADBAND: 3 (DEFAULT) THIS IS THE ACTUAL +/- VALUE
- PARAMETER 117 CO2 DAMPER MAX OPEN %: 50
- PARAMETER 118 CO2 START OPEN PPM: 1200
- PARAMETER 119 CO2 FULL OPEN PPM: 1500
- PARAMETER 137 OCCHEAT SET POINT: 68 (BACK UP)
- PARAMETER 139 OCC COOLING SET POINT: 72 (BACK UP)
- PARAMETER 154 COOL BLOWER MODE: ON CONTINUOUS 1

CFM VALUES / MSAV FAN SPEEDS (AIR BALANCER TO DEFINE / IF APPLICABLE):

- HEAT CFM VALUE: PER THE HVAC SCHEDULE
- HIGH COOL CFM VALUE: PER THE HVAC SCHEDULE
- LOW COOL CFM VALUE: MATCH THE HIGH COOL CFM VALUE
- VENTILATION CFM VALUE: MATCH THE HIGH COOL CFM VALUE

RTU-1, 2, & 3 TEST AND BALANCE NOTES

- TEST AND BALANCE CONTRACTOR TO OBTAIN INITIAL BALANCE OF COOLING CFM FOR RTU USING FAN SNEAVE ADJUSTMENT TO WITHIN +/- 3% SCHEDULED COOLING CFM. PRODIGY CONTROLLER MAY BE USED FOR FINAL 5% TO OBTAIN SCHEDULED COOLING CFM.
- SET MINIMUM OUTSIDE AIR DAMPER POSITION FOR COOLING AND VERIFY OUTSIDE AIR CFM PER RTU SCHEDULE.
- NOT USED
- NOT USED
- USING PRODIGY CONTROLLER, VERIFY HEATING CFM EQUALS COOLING CFM.
- ALL PRODIGY CONTROLLER SETTINGS OTHER THAN THOSE MENTIONED ABOVE SHALL REMAIN AS THEIR DEFAULT VALUE AS SET FROM THE FACTORY.
- VERIFY POSITIVE BUILDING PRESSURE.

AIR BALANCE SCHEDULE

SYSTEM	CFM
RTU-1	+500
RTU-2	+500
RTU-3	+300
EF-1	-800
BUILDING POSITIVE PRESSURE	+500

RTU-1, 2, & 3 SEQUENCE OF OPERATION

- SUPPLY AIR BLOWER SPEED UNIT HAS FOLLOWING SUPPLY AIR BLOWER SPEED SETTINGS THAT PERTAIN TO THIS INSTALLATION:
- COOLING AIR BLOWER SPEED
 - HEATING AIR BLOWER SPEED
- COOLING MODE
- Y1 DEMAND: COMPRESSOR 1 OPERATES AND SUPPLY AIR BLOWER OPERATES AT COOLING SPEED.
 - Y2 DEMAND: ALL COMPRESSORS OPERATE AND SUPPLY AIR BLOWER OPERATES AT COOLING SPEED.
- DEHUMIDIFICATION MODE
- IF THE UNIT RECEIVES A CALL FOR DEHUMIDIFICATION, ECONOMIZER FREE COOLING IS LOCKED OUT (ON UNITS EQUIPPED WITH ECONOMIZER).
 - CALL FOR DEHUMIDIFICATION, NO Y1, Y2 DEMAND: 1ST STAGE COMPRESSOR OPERATES, SUPPLY AIR BLOWER OPERATES AT COOLING SPEED, AND THE REHEAT VALVE IS ENERGIZED.
 - Y1 DEMAND WITH A CALL FOR DEHUMIDIFICATION: ALL COMPRESSORS OPERATE, SUPPLY AIR BLOWER OPERATES AT COOLING SPEED AND THE REHEAT VALVE IS ENERGIZED.
 - Y2 DEMAND WITH A CALL FOR DEHUMIDIFICATION: ALL COMPRESSORS OPERATE, SUPPLY AIR BLOWER OPERATES AT COOLING SPEED, AND THE REHEAT VALVE IS DE-ENERGIZED.
- HEATING MODE (ELECTRIC HEAT)
- Y1 DEMAND: 1ST STAGE ELECTRIC HEAT IS ENERGIZED AND THE SUPPLY AIR BLOWER OPERATES AT HEATING SPEED.
 - Y2 DEMAND: 2ND STAGE ELECTRIC HEAT IS ENERGIZED AND THE SUPPLY AIR BLOWER OPERATES AT HEATING SPEED.
- MODULATING OUTDOOR AIR DAMPER
- THE MINIMUM DAMPER POSITION FOR "OCCUPIED HIGH BLOWER" IS ADJUSTED DURING UNIT SETUP TO PROVIDE MINIMUM FRESH AIR REQUIREMENTS PER RTU SCHEDULE.
- WHEN SUPPLY AIR BLOWER IS OFF, THE OUTDOOR AIR DAMPER IS CLOSED.
 - WHEN UNIT IS IN OCCUPIED MODE AND SUPPLY AIR BLOWER IS OPERATING, THE OUTDOOR AIR DAMPER IS AT MINIMUM "HIGH BLOWER" POSITION.

2600 Mainland Center Parkway
Suite #200
Maitland, FL 32751
P (407) 661-9100
F (407) 661-9101
C-p.com

CUHACI PETERSON

Copyright © 2020. All rights reserved. Specifications, conditions, field notes, notes and other documents are instruments of service prepared by Cuhaaci & Peterson, P.A. C.P. & P. shall remain the property of C.P. & P. No part of this document may be reproduced or transmitted in any form or by any means, including the copyright owner. Any use or reproduction of this document without written permission from C.P. & P. is a violation of Federal copyright laws.

CLIENT NAME
WAWA
260 WEST BALTIMORE PIKE
WAWA, PENNSYLVANIA 19063

PROJECT NAME
WAWA F88FB V2021.3
STORE #5453
US 301 & SE 52ND ST
OCALA, FL

REVISION
No. Description
11-15-2023 PRE-BID SET
07/19/2024
11-15-2023 CONSTRUCTION SET 1/009/2024

PROJECT NO. 2023034
DATE 11-15-2023
DRAWN PAK
CHECKED ESD

M3.0

HVAC SCHEDULES, NOTES AND DETAILS

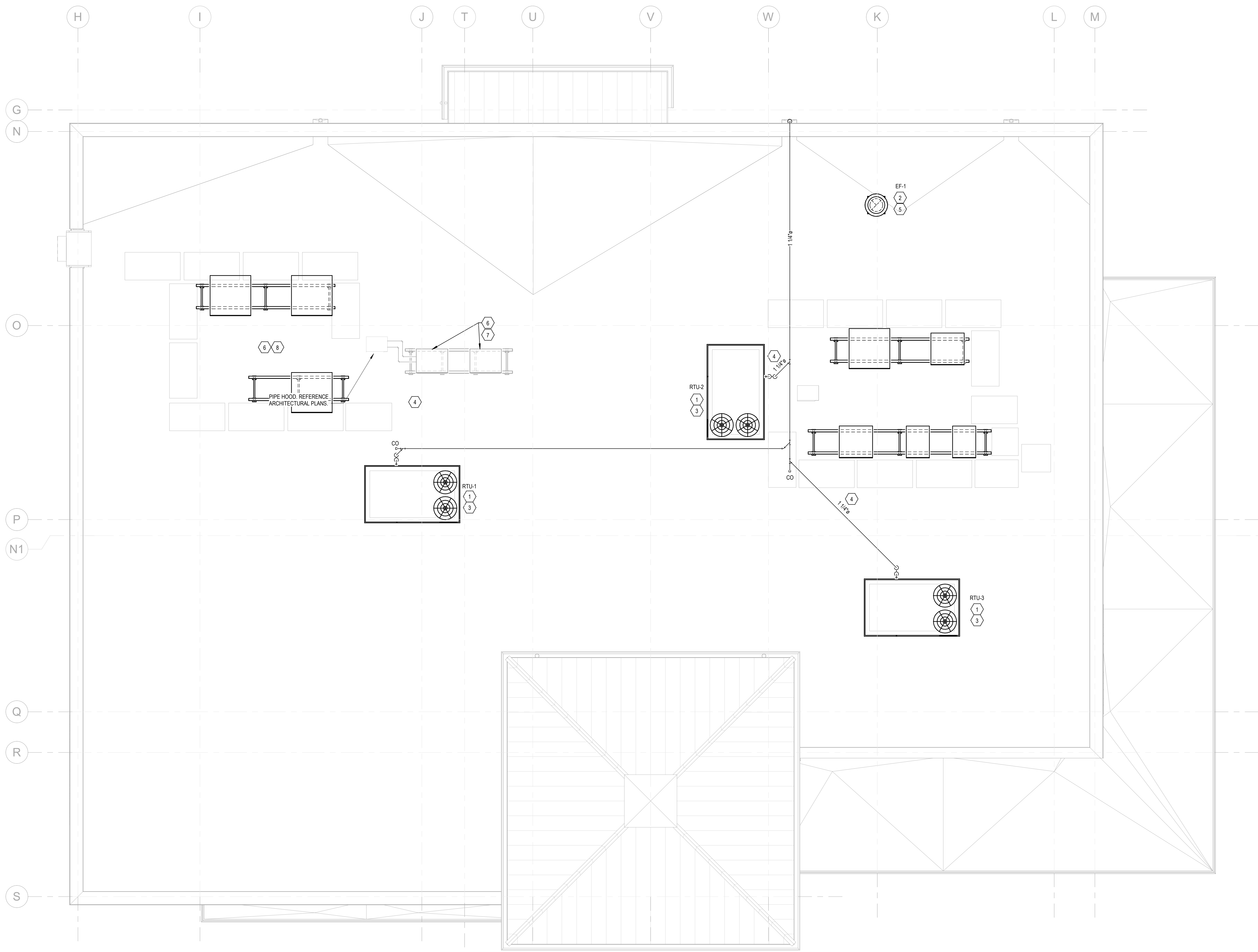

KEY NOTES:

- 1 FACTORY INSTALLED SMOKE DETECTOR IN MAIN SUPPLY AND RETURN OF EACH ROOFTOP UNIT.
- 2 INSTALL ROOF MOUNTED EXHAUST FAN PER DETAIL ON SHEET M3.0. COORDINATE EXACT LOCATION OF FAN PENETRATION WITH ARCHITECTURAL ROOF PLAN. TRANSITION GALVANIZED DUCTWORK AS NECESSARY FROM FAN INTO CEILING/JOIST SPACE. SEE SHEET M1.0 FOR CONTINUATION.
- 3 PROVIDE FLEXIBLE CONNECTIONS BETWEEN ALL DUCTWORK AND MECHANICAL UNITS.
- 4 ROUTE SCH. 40 P.V.C. CONDENSATE DRAIN PIPING ALONG ROOF. SUPPORT PIPING PER DETAIL ON SHEET M3.0.
- 5 MAINTAIN A MINIMUM 10' CLEARANCE BETWEEN OUTSIDE AIR INTAKES AND EXHAUST TERMINATIONS ON ROOF.
- 6 FOOD SERVICE REFRIGERATION EQUIPMENT PROVIDED BY OTHERS.
- 7 FOOD SERVICE REFRIGERATION EQUIPMENT MOUNTED ON PRE-ENGINEERED RACK. REFER TO "CONDENSING UNIT ROOFING SUPPORT DETAIL" ON ARCHITECTURAL SHEETS FOR FLORIDA PRODUCT APPROVAL INFORMATION.
- 8 FOR SPECIFIC WIND LOADING REQUIREMENTS NOT TO EXCEED 130 MPH, SEE STRUCTURAL DRAWINGS.

SHEET GENERAL NOTE:

CONTRACTOR RESPONSIBLE FOR USING CURBS PLUS CLIPS ON ALL RTUS. CLIPS ARE DELIVERED TO SITE AS SEPARATE PACKAGE.

1 HVAC ROOF PLAN
M2.0 1/4" = 1'-0"

2600 Maitland Center Parkway
Suite #200
Maitland, FL 32751
P (407) 661-9100
F (407) 661-9101
c-p.com
FIRM LICENSE NUMBER: 1341-000000



COPYRIGHT ©: All reports, plans, specifications, computer files, field data, notes and other documents are instruments of service prepared by CuHaci & Peterson, C.S.P.C. All instruments of service remain the property of C. & P. C. & P. shall retain all copyright, trademark and other intellectual rights, including the copyright therein. Any use or reproduction of this document without written permission from C. & P. is a violation of Federal copyright laws.

CLIENT NAME
WAWA
260 WEST BALTIMORE PIKE
WAWA, PENNSYLVANIA 19063

PROJECT NAME
WAWA F85FB V2021.3
STORE #5453
US 301 & SE 32ND ST
OCALA, FL

SHEET TITLE
HVAC ROOF PLAN

Revision Schedule	
No.	Description
A	PRELIMINARY SET
B	BID SET
C	CONSTRUCTION SET

PROJECT NO. 2023034	DATE 11-16-2023	DRAWN PAK	CHECKED ESD
------------------------	--------------------	--------------	----------------

M2.0