

SUBMITTAL REVIEW COMMENTS

PROJECT Verdad - The Grove
PROJECT NO 2150004838
DATE 1/5/2023
SUBMITTAL Duct Standards
SUBMITTAL NO 230000-4.0
REVIEWER MJW
HENDERSON NO M005

<input checked="" type="checkbox"/> Approved	Fabrication and/or installation may be undertaken. Approval does not authorize changes to the contract sum or contract time.
<input type="checkbox"/> Approved as Corrected	
<input type="checkbox"/> Revise and Resubmit	Fabrication and/or installation may not be undertaken. In resubmitting, limit corrections to items marked.
<input type="checkbox"/> Rejected	
<input type="checkbox"/> No Action Taken	Submittal either not required for this item or provided for information only. Contract requirements should be followed in all cases.

Review/approval neither extends nor alters any contractual obligations of the Engineer or Contractor. Checking of submittals is only for general conformance with the design concept of the project and general compliance with the information given in the contract documents. Any action shown is subject to the general requirements of the plans and specifications. Contractor is responsible for dimensions, quantities, and coordination between trades and for coordinating approved items and accepted alternates.

HENDERSON ENGINEERS, INC.

ACTION CODES

1	2	3	4	5	6
Approved	Approved as Corrected	Revise & Resubmit Items Noted	Rejected	Not Reviewed	For Information Only

(Action Item Codes 1, 2, 5 or 6 are not to be resubmitted.)

COMMENT #	ACTION CODE	DESCRIPTION	COMMENTS
1	1	Galvanized Ducts (Pg 5 & 6 of 63)	-Approved per mech specification.
2	1	Liner Pins (Pg 7 & 13-14 of 63)	-Approved per mech specification.
3	1	Liner Adhesive (Pg 8 & 11-12 of 63)	-Approved per mech specification.
4	1	Liner (Pg 9 & 10 of 63)	-Approved per mech specification.
5	1	Turning Vanes (Pg 15 -18 of 63)	-Approved as required.
6	1	Seams (Pg 19 of 63)	-Approved per mech specification.

COMMENT #	ACTION CODE	DESCRIPTION	COMMENTS
7	1	Flexible Duct Connector (Pg 20 & 21 of 63)	-Approved per mech specification.
8	1	Dampers (Pg 22 of 63)	-Approved per mech specification.
9	1	Duct Access Doors (Pg 23 of 63)	-Approved as required.
10	1	Low Pressure Duct, Flex & Misc Accessories (Pg 24 -27 of 63)	-Approved per mech specification.
11	1	DuroDyne Dyn-O-Ties (Pg 28 & 29 of 63)	-Approved per mech specification.
12	1	Duct Sealant (Pg 30 of 63)	-Approved per mech specification.
13	1	Metal Spin in Starting Collar (Pg 31 of 63)	-Approved as required.
14	1	Snaplock Furnace Pipe (Pg 32 - 35 of 63)	-Approved per mech specification.
15	1	Hangers, Supports & Accessories (Pg 32 - 63)	-Approved per mech specification and as required.

Note: Henderson's processing of these submittals does not relieve other members of the design and construction team from reviewing submittals for coordination, compliance and performance or reviewing submittals as outlined in the contract documents or both.



Submittal Transmittal

Aria Group Architects, Inc. | 830 North Blvd Oak Park IL 60301 United States

PROJECT: Perrys-Verdad The Grove 214735.000 DATE SENT: 1/3/2023
RETURN BY: 1/5/2023
SUBJECT: 230000-4.0_Duct Standards SUBMITTAL ID: 034
TYPE: Submittal TRANSMITTAL ID: 00154
PURPOSE: For Review VIA: Info Exchange
SPEC SECTION: 230000

FROM

NAME	COMPANY	EMAIL	PHONE
SHELLIE HALKYARD	Aria Group Architects, Inc.	shalkyard@ariainc.com	(708) 445-8400

TO

NAME	COMPANY	EMAIL	PHONE
Rhonda Charlett	Henderson Engineers, Inc.	Rhonda.Charlett@hendersonengineers.com	(913) 742-5367
Coy Macy	Henderson Engineers, Inc.	Coy.Macy@hendersonengineers.com	(913) 742-5611

REMARKS: **Please see the enclosed Duct Standards submittal for review.**
Thank you

DESCRIPTION OF CONTENTS

QTY	DATED	TITLE	NUMBER	NOTES
1	12/28/2022	230000-4-0 - Submittal Form.pdf		
1	12/28/2022	230000-4.0_ Airco Duct Standards.pdf		

COPIES:

BRIAN ZIELINSKI (Aria Group Architects, Inc.)
SHELLIE HALKYARD (Aria Group Architects, Inc.)
PAUL NAGTALON (Aria Group Architects, Inc.)



Submittal

International Contractors, Inc.
 1 Mid America Plaza, 7th Floor
 Oakbrook Terrace, Illinois 60181
 Phone: (630) 834-8043
 Fax: (630) 834-8046
 www.icibuilds.com

Project: 001223 - Verdad the Grove, Austin, TX
 2701 Perseverance Drive
 Austin, Texas 78731

230000-4.0_Duct Standards

SPEC SECTION:	230000 - HVAC	SUBMITTAL #:	230000-4
STATUS:	Open	DATE CREATED:	12/28/2022
ISSUE DATE:	12/28/2022	REVISION:	0
RESPONSIBLE CONTRACTOR:	AiRCO Mechanical	RECEIVED FROM:	Shayne Terry
RECEIVED DATE:	12/27/2022	SUBMIT BY:	12/28/2022
FINAL DUE DATE:	01/04/2023	LOCATION:	
TYPE:	Product Manual	COST CODE:	01-0011 - Project Engineer - Office
APPROVERS:	Victor Baez (International Contractors, Inc.), Shellie Halkyard (Aria Group Architects, Inc.), Paul Nagtalon (Aria Group Architects, Inc.)	CREATED BY:	Victor Baez (International Contractors, Inc.)

BALL IN COURT:
 Shellie Halkyard (**Aria Group Architects, Inc.**), Paul Nagtalon (**Aria Group Architects, Inc.**)

DISTRIBUTION:
 Brian Zielinski (**Aria Group Architects, Inc.**) , Jack Moore (**International Contractors, Inc.**) , Ricardo Bustos (**International Contractors, Inc.**) , Scott Leadbetter (**International Contractors, Inc.**) , Austin Darrell (**International Contractors, Inc.**)

DESCRIPTION:

ATTACHMENTS:

SUBMITTAL WORKFLOW

#	NAME	SUBMITTER/APPROVER	DUE DATE
1	Shayne Terry	Submitter	12/28/2022
2	Victor Baez	Approver	12/28/2022
3	Shellie Halkyard	Approver	1/4/2023
4	Paul Nagtalon	Approver	1/4/2023

INTERNATIONAL CONTRACTORS, INC.
 INTERNATIONAL CONTRACTORS REVIEW OF THIS SUBMITTAL IS FOR GENERAL CONFORMANCE WITH THE CONTRACT DOCUMENTS. SUBCONTRACTOR IS RESPONSIBLE FOR DETAILS AND ACCURACY, FOR CONFIRMING AND VERIFYING ALL DIMENSIONS AND QUANTITIES, AND ASSURING COORDINATION WITH RESPECTIVE RELATED TRADES AND WORK.
 ICI REVIEWER: VICTOR BAEZ DATE: 12/28/2022
 TIME:



Submittal

International Contractors, Inc.
 1 Mid America Plaza, 7th Floor
 Oakbrook Terrace, Illinois 60181
 Phone: (630) 834-8043
 Fax: (630) 834-8046
 www.icibuilds.com

Project: 001223 - Verdad the Grove, Austin, TX
 2701 Perseverance Drive
 Austin, Texas 78731

230000-4.0_Duct Standards

SPEC SECTION:	230000 - HVAC	SUBMITTAL #:	230000-4
STATUS:	Open	DATE CREATED:	12/28/2022
ISSUE DATE:	12/28/2022	REVISION:	0
RESPONSIBLE CONTRACTOR:	AiRCO Mechanical	RECEIVED FROM:	Shayne Terry
RECEIVED DATE:	12/27/2022	SUBMIT BY:	12/28/2022
FINAL DUE DATE:	01/04/2023	LOCATION:	
TYPE:	Product Manual	COST CODE:	01-0011 - Project Engineer - Office
APPROVERS:	Victor Baez (International Contractors, Inc.), Shellie Halkyard (Aria Group Architects, Inc.), Paul Nagtalon (Aria Group Architects, Inc.)	CREATED BY:	Victor Baez (International Contractors, Inc.)

BALL IN COURT:
 Victor Baez (International Contractors, Inc.)

DISTRIBUTION:
 Brian Zielinski (Aria Group Architects, Inc.) , Jack Moore (International Contractors, Inc.) , Ricardo Bustos (International Contractors, Inc.) , Scott Leadbetter (International Contractors, Inc.) , Austin Darrell (International Contractors, Inc.)

DESCRIPTION:

ATTACHMENTS:

SUBMITTAL WORKFLOW

#	NAME	SUBMITTER/APPROVER	DUE DATE
1	Shayne Terry	Submitter	12/28/2022
2	Victor Baez	Approver	12/28/2022
3	Shellie Halkyard	Approver	1/4/2023
4	Paul Nagtalon	Approver	1/4/2023

<u>INTERNATIONAL CONTRACTORS, INC.</u>	
INTERNATIONAL CONTRACTORS REVIEW OF THIS SUBMITTAL IS FOR GENERAL CONFORMANCE WITH THE CONTRACT DOCUMENTS. SUBCONTRACTOR IS RESPONSIBLE FOR DETAILS AND ACCURACY, FOR CONFIRMING AND VERIFYING ALL DIMENSIONS AND QUANTITIES, AND ASSURING COORDINATION WITH RESPECTIVE RELATED TRADES AND WORK.	
ICI REVIEWER: VICTOR BAEZ	DATE: 12/28/2022
	TIME:



1000 South IH-35, Round Rock, TX 78681
Phone | 512-906-3963 • Fax | 512-837-3112 • www.aircomechanical.com

Materials:

Duct Work Standards, Hangers, Flex & Misc Accessories

Spec Section Reference:

Airco Contact:

Phone:

Email:

Sub-Sections:

- 1) Medium Pressure Duct Standards w/ Project Specific Requirements
- 2) Low Pressure Duct, Flex & Misc Accessories
- 3) Hangers, Supports & Accessories



1000 South IH-35, Round Rock, TX 78681
Phone | 512-906-3963 • Fax | 512-837-3112 • www.aircomechanical.com

Sub-Section:

1) Medium Pressure Duct Standards

Spec Section Reference:

Airco Contact:

Phone:

Email:

Please Note:

All rectangular duct work is fabricated per SMACNA Standards in Airco's fabrication plant in Round Rock, Texas with a 27% average recycled content. 100% of galvanized, steel, aluminum and stainless steel is recycled through Airco's Environmental Impact Reduction Program.

Airco's mandatory policy is that 100% of all fabricated duct work is blown clean and ends are wrapped with a thick mm plastic before leaving the fabrication area.

Please see project specific requirements to follow.



CALIFORNIA STEEL INDUSTRIES, INC.

1 California Steel Way; P.O. Box 5080
Fontana, California 92335
909.350.6300

April 5, 2016

Geoff Berger
Curtis Steel Company
6504 Hurst St
Houston TX 77008

E-Mail: geoffberger@curtissteelco.com
Fax:

TO WHOM IT MAY CONCERN:

(Revised 01/05/16)

SUBJECT: LEED Compliance/Recycled Content of Steel Products Produced by California Steel Industries Inc.

California Steel Industries Inc. has no steelmaking facilities, instead it purchases steel slabs from various qualified sources within the North American domestic market and internationally. These sources are comprised of steelmakers using either the Basic Oxygen Furnace/BOF or the Electric Arc Furnace/EAF process for steelmaking. Common steelmaking practice from the BOF assumes a scrap charge of about 25 to over 30% depending on steel type and market availability of scrap at any given time. Steelmaking practice for the EAF may comprise a variety of scrap charge mixes up to 100% scrap in some instances.

Based on current and planned trends of aggregate steel slab supply from all sources, CSI projects the recycled content of the products produced to achieve at least 27%. The 27% is comprised of a nominal 25% post-consumer content and a 2% post-industrial content. Individual heats and heat lots may vary based on the circumstances noted above.

Please note that all scrap and subsequent re-cycling/melting and slab casting operations occurs well beyond 500 miles of CSI's rolling mills in Fontana, California. This is because there is no scrap/steel melting and slab casting mills in the United States west of St. Louis, Missouri. Therefore none of the western states are within 500 miles of any steel melting/scrap recycling facility capable of making sheet/plate steel. This includes all of California, Oregon, Washington, Nevada, Arizona, New Mexico, Idaho, Utah, Montana, North and South Dakota, Wyoming, and Colorado.

Should you have further questions concerning this subject, please contact your CSI's Account Representative, at your earliest convenience.

Sincerely,

CALIFORNIA STEEL INDUSTRIES, INC.

Ralph P. Hayden, Jr.
Chief Metallurgist and Manager Quality Services
Specifications

RPH:bac
2016 LEEDS-CUR-GB-RPH

SHOP STANDARDS

SHEETMETAL FABRICATION - THIS SECTION WILL DESCRIBE SHOP FABRICATION STANDARDS WHICH ARE PRODUCED BY SHEETMETAL SHOP.

GALVANIZED DUCTS

GAUGE BREAKS – RECTANGULAR DUCTWORK

AIRCO LOW PRESSURE 1/2" W.G.	5 FT. LENGTH DUCT SIZE	GAUGE	CONNECTORS TYPE
	0" TO 60"	24	0" TO 16" FLAT – S
	61" TO 84"	22	17" TO 54" 1" STD-S
	85" AND UP	20	56" TO 72" 1-1/2 STD 73" AND UP DM.
<hr/>			
1" W.G.	0" TO 48"	24	0" TO 12" FLAT –S
	49" TO 60"	22	13" TO 42" 1" STD.
	61" AND UP	20	43" TO 60" 1-1/2 STD 61" AND UP DM.
<hr/>			
2" W.G.	0" TO 30"	24	0" TO 10" FLAT –S
	31" TO 42"	22	11" TO 36" 1" STD.
	43" AND UP	20	37" TO 48" 1-1/2 STD 49" AND UP DM.
<hr/>			
3" W.G.	0" TO 26"	24	0" TO 10" FLAT –S
	27" TO 30"	22	11" TO 30" 1" STD.
	31" AND UP	20	31" TO 48" 1-1/2 STD 49" AND UP DM.
<hr/>			
4" W.G.	0" TO 22"	24	0" TO 8" FLAT-S
	21" TO 30"	22	9" TO 30" 1" STD.
	31" AND UP	20	31" TO 48" 1-1/2 STD 49" AND UP DM.
<hr/>			
6" W.G.	0" TO 12"	24	0' TO 8" FLAT-S
	13" TO 24"	22	9" TO 30" 1" STD.
	25" AND UP	20	31" TO 42" 1-1/2 STD 43" AND UP DM.

STAINLESS STEEL DUCTS

LOW PRESSURE	0" TO 30"	26	S & D
	31" TO 45"	24	
	46" TO 55"	22	
	56" AND UP	18	

BLACK IRON DUCTS

LOW PRESSURE	0" AND UP	16	WELDED
--------------	-----------	----	--------

ALUMINUM DUCTS

LOW PRESSURE	0" TO 30"	22	0" TO 18" FLAT-S
	31" TO 42"	20	19" TO 36" 1"STD.
	43" AND UP	18	37" AND UP 1-1/2 STD

Project Specific Requirements:

1) All Duct will be blown out clean after fabrication, the ends will be sealed with thick mm wrap for storage and delivery, and wrap will be maintained onsite, with loose ends and transfer ducts sealed every day during the construction process

LINER- THIS SECTION WILL DETAIL SHOP STANDARD LINERS USED IN SHEETMETAL SHOP.

AIRCO STANDARD

THICKNESS	DENSITY	MANUFACTURE	TYP. USE	PART #
1"	1-1/2#	OWENS CORNING	OUT OF TOWN OR	540010
1/2"	2#	OWENS CORNING	OPEN RETURN	540009
1-1/2"	1-1/2#	OWENS CORNING	R6 JOBS AUSTIN>40	540021

THESE PRODUCTS ARE:

- A) UL APPROVED
- B) 25/50 FLAME/SMOKE
- C) COATED EDGES

STANDARD ROLL LENGTHS- 1" 100 FT./ 1-1/2" 50 FT.
STANDARD ROLL WIDTH – 59- 1/2"

INSULATION STANDARDS

1/2"	3#	
1"	1 1/2#	R-4 Liner
1 1/2"	2 3/4#	R-6 Liner
2"	1 1/2#	R-8 Liner

LINER PINS- THIS SECTION WILL DETAIL STANDARD PIN TYPES AND APPLICATIONS.

PRODUCT APPLICATION

DURO-DYNE # FTC34	USED FOR 1" PER ATTACHED DETAIL
DURO-DYNE #CPB118	USED FOR 1-1/2" LINER
DURO-DYNE #PTC12	USED FOR 1/2" LINER
DURO-DYNE #CPB150	USED FOR 2" LINER

LINER ADHESIVE- THIS SECTION WILL DETAIL TYPE OF GLUE AND APPLICATION USED BY SHEETMETAL SHOP.

PRODUCT- FOSTERS 8500 55 GAL.

APPLICATION- SPAYED ON AND ATTACHED WITH PINS PER SMACNA DETAIL BELOW.

No. Pins	Liner Interior Width
0	8" dn
2	9"-16"
3	17"-28"
4	29"-40"
5	41"-52"
6	53"-64"
7	65"-76"
8	77"-88"
9	89"-100"

WHEN VELOCITY EXCEEDS 4000 FPM USE METAL NOSING ON EVERY LEADING EDGE. NOSING MAY BE FORMED ON DUCT OR BE CHANNEL OR ZEE ATTACHED BY SCREWS, RIVETS OR WELDS.

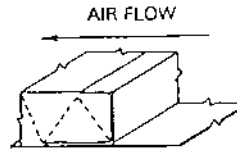

DETAIL-A

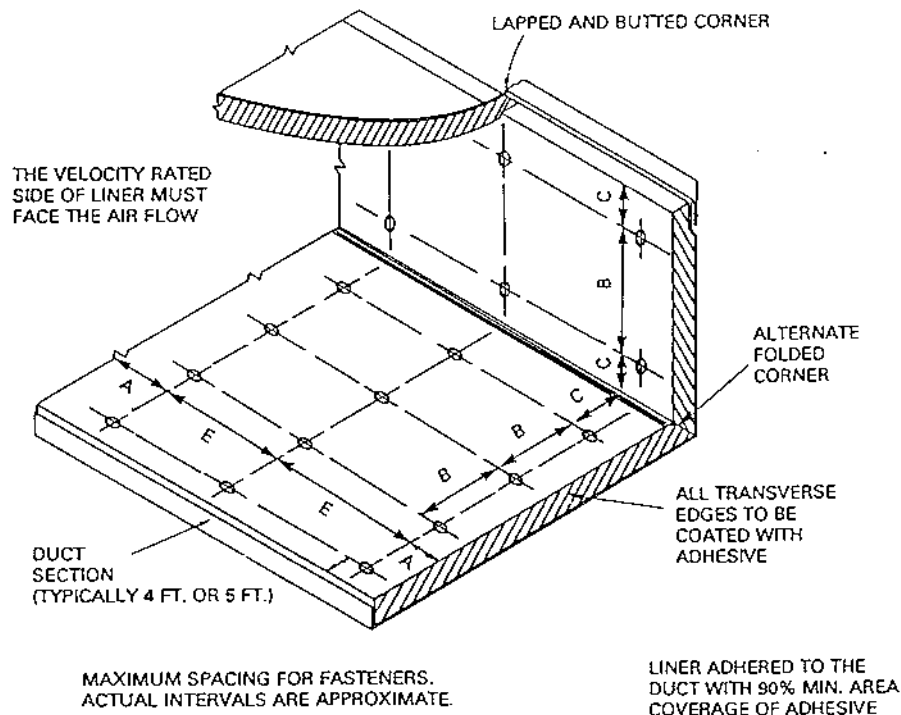

Velocity*	Dimensions			
	A	B	C	E
0-2500 FPM	3"	12"	4"	18"
2501-6000 FPM	3"	6"	4"	16"

*UNLESS A LOWER LEVEL IS SET BY MANUFACTURER OR LISTING AGENCY



AKOUSTI-LINER™

Temperature Limit: 250°F (121°C)

DESCRIPTION

Akousti-Liner insulation is a flexible duct liner providing both thermal and acoustical insulation. It is manufactured from inorganic glass fibers bonded by a thermosetting binder. The airstream surface is faced with a black mat bonded to the black glass mineral wool substrate. Akousti-Liner insulation is offered with or without edge coating to seal fibers.

APPLICATION

Manson Insulation Akousti-Liner insulation is a durable, flexible liner used extensively in flat and irregular shaped ductwork.

INSTALLATION

All duct liner shall be installed in accordance with the requirement of the NAIMA Fibrous Glass Duct Liner Standard or SMACNA HVAC Duct Construction Standard and the project specification. Liner shall be adhered with adhesive (complying with ASTM C916) and mechanical fasteners.

LIMITATION

Duct liner should be kept clean and dry during shipping, storage, installation and system operation. When condensation is permitted to occur between nested liner and galvanized steel panels, discoloration of the metal may occur.

SPECIFICATION COMPLIANCE

ASTM C1071 Type I

- Standard specification for Thermal and Acoustical Insulation (Glass, Fiber, Duct Lining Material)

NFPA 90A

- Standard for the Installation of Air-Conditioning and Ventilating Systems

NFPA 90B

- Standard for the Installation of Warm Air Heating and Air-Conditioning Systems

City of New York MEA 323-83-M

California Title 24

CAN/CGSB 51.11-92

PRODUCT FEATURES

Sustainability

- Over 50% post-consumer recycled glass
- Greenguard GOLD certified for superior indoor air quality performance
- EUCEB
- No added formaldehyde

Surface Burning Characteristics

- UL/ULC Listed
- Does not exceed 25 Flame Spread, 50 Smoke Developed when tested in accordance with ASTM E 84, CAN/ULC S102-M88, NFPA 255 and UL 723

Air Flow Characteristics (ASTM C1071)

- Air velocity rating 6,000 ft/min (30.5 m/s)

Water Vapor Absorption (ASTM C1104)

- Less than 3% by weight

Corrosiveness (ASTM C665)

- Will not accelerate corrosion

Bacteria Resistance (ASTM G22)

- Does not breed or promote growth

Fungi Resistance (ASTM C1338, ASTM G21)

- Airstream surface is coated with an EPA-registered anti-microbial agent; does not breed or promote growth

Hot Surface Performance (ASTM C411)

- Operating temperature limit: Max. 250°F (120°C)

DecaBDE Free

- Does not contain polybrominated diphenyl ethers (PBDE) such as: Penta – BDE, Octa – BDE or Deca – BDE

ACOUSTICAL PERFORMANCE
ASTM C423, TYPE A MOUNTING

DENSITY	THICKNESS	FREQUENCY						
		125	250	500	1000	2000	4000	NRC
2.0 PCF (32 kg/m ³)	½" (13 mm)	0.09	0.14	0.40	0.60	0.73	0.82	0.45
	1" (25 mm)	0.25	0.35	0.69	0.89	0.96	1.01	0.70
1.5 PCF (24 kg/m ³)	1" (25 mm)	0.18	0.36	0.59	0.86	0.95	0.90	0.70
	1½" (38 mm)	0.35	0.51	0.83	0.93	0.97	0.96	0.80
	2" (51 mm)	0.34	0.64	0.96	1.03	1.00	1.03	0.90

THERMAL PERFORMANCE
ASTM C177 - 75°F (24°C) MEAN TEMPERATURE

DENSITY	THICKNESS	C-VALUE		R-VALUE	
		BTU/ FT ² .HR.°F	W/M ² .°C	FT ² .HR.°F/ BTU	M ² .°C/W
2.0 PCF (32 kg/m ³)	½" (13 mm)	0.48	2.73	2.1	0.37
	1" (25 mm)	0.24	1.36	4.2	0.74
1.5 PCF (24 kg/m ³)	1" (25 mm)	0.24	1.42	4.2	0.74
	1½" (38 mm)	0.17	0.97	6.0	1.06
	2" (51 mm)	0.13	0.74	8.0	1.41

GLASS MINERAL WOOL AND MOLD

Glass mineral wool insulation will not sustain mold growth. However, mold can grow on almost any material when it becomes wet and contaminated. Carefully inspect any insulation that has been exposed to water. If it shows any sign of mold, it must be discarded. If the material is wet but shows no evidence of mold, it should be dried rapidly and thoroughly. If it shows signs of facing degradation from wetting, it should be replaced. Air handling insulation used in the air stream must be discarded if exposed to water.

NOTES

The chemical and physical properties of Manson Insulation Akousti-Liner insulation represent average values determined in accordance with accepted test methods. The data is subject to normal manufacturing and testing variations. The data is supplied as a technical service and is subject to change without notice. References to numerical flame spread ratings are not intended to reflect hazards presented by these or any other materials under actual fire conditions.

Check with your Manson Insulation Territory Manager to assure information is current.

FRICITION LOSS (INCHES OF WATER PER 100')

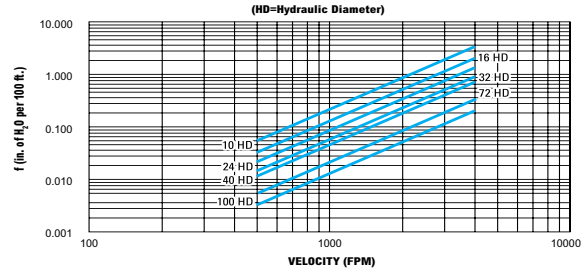

FPM	HYDRAULIC DIAMETER						
VELOCITY	10"	16"	24"	32"	40"	72"	100"
500	0.054	0.030	0.018	0.012	0.009	0.005	0.003
600	0.077	0.042	0.025	0.018	0.013	0.007	0.004
700	0.104	0.057	0.034	0.024	0.018	0.009	0.006
800	0.134	0.074	0.044	0.031	0.023	0.011	0.008
900	0.169	0.093	0.056	0.039	0.029	0.014	0.010
1000	0.207	0.114	0.068	0.048	0.036	0.018	0.012
2000	0.806	0.443	0.266	0.186	0.141	0.069	0.046
3000	1.797	0.988	0.594	0.415	0.315	0.153	0.103
4000	3.179	1.748	1.050	0.734	0.557	0.271	0.181
5000	4.952	2.724	1.636	1.143	0.867	0.422	0.283

MECHANICAL FASTENER LOCATION

	VELOCITY/FPM (METERS/SECOND)	0-255 (0-12.7)	2501-5000 (12.7-25.4)
A	From corners of duct	4" (102 mm)	4" (102 mm)
B	From transverse of duct	3" (76 mm)	3" (76 mm)
C	Across width of duct, on centers (min. 1/side)	12" (305 mm)	6" (152 mm)
D	Across length of duct, on centers (min. 1/side)	18" (457 mm)	16" (406 mm)

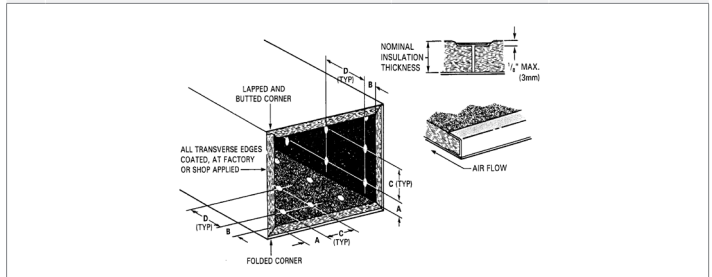



85-00

Product Data Sheet

PROPERTIES

COLOR:

White (Wet), Translucent (Dry)

APPLICATION CONSISTENCY:

Smooth, Excellent Spray and Extrusion

AVERAGE WEIGHT / U.S. GALLON (ASTM D 1875):

8.8 lbs. (1.05 kg/l)

AVERAGE NON-VOLATILE (ASTM D 1644):

38% by volume (40% by weight)

COVERAGE RANGE:

400-500 ft²/gal (9.2-12.3 m²/l)

DRYING TIME (75°F (24°) 50% RH):

Set to Touch: 15 minutes

Dry Through: 3 hours

BONDING TIME:

0-10 minutes

SERVICE TEMPERATURE LIMITS (FSTM 70):

-20°F to 200°F (-29°C to 93°C)

TIME TO FIBER TEAR:

30-60 minutes, 1" Duct Liner

BOND STRENGTH TO GALVANIZED STEEL:

40°F (4°C) 20 Hours 2.5±0.5 pli

WET FLAMMABILITY (ASTM D 3278):

No flash to boiling, >200°F (93°C)

SURFACE BURNING CHARACTERISTICS (ASTM E 84):

Flame Spread: 5

Smoke Developed: 0

Coverage Rate: 400 ft²/gal (9.8 m²/l)

Applied to 1/4 inch (6.4mm) inorganic reinforced cement board. The flame spread may vary at different product thicknesses and/or when applied over other surfaces.

™ Trademark of H.B. Fuller Construction Products Inc.

Visit us on the web at www.fosterproducts.com

FOSTER LINE-FAS™ ADHESIVE



FOSTER LINE-FAS ADHESIVE is an economical pure polymer water-base duct liner adhesive with excellent fire resistance, tack development, and bond strength.

LINE-FAS ADHESIVE is intended for high volume spray and coil line operations. It runs smoothly on spray head, extrusion, or roll coater equipment. Its fine atomization makes it ideal for manual spray applications as well.

LINE-FAS ADHESIVE is solvent free and features an exceptionally mild odor with very low VOC level. It has a mild/negligible odor when wet and no odor when dry.

LINE-FAS ADHESIVE meets ASTM C-916 Type II (ASC-A-7001, Type II) adhesive requirements. It is intended for bonding fiberglass and mineral wool duct liner insulation to galvanized steel.

LINE-FAS ADHESIVE meets NFPA 90A and 90B 25/50 requirements.

LINE-FAS ADHESIVE meets requirements for LEED IEQ 4.1 Low-Emitting Materials, Adhesives and Sealants. VOC: 5 g/l, less water and exempt solvents.

LINE-FAS ADHESIVE is produced under the classification and follow-up service of Underwriter's Laboratories, Inc.

ASTM-C-916 PERFORMANCE

7.1 Bond Strength @ R.T. 3.0±1.0 pli

7.2 Bond Strength @ 95% RH 2.5±0.5 pli

7.3 Bond Strength @ 158°F 2.5±0.5 pli

7.4 Bond Retention, 90 day, 158°F-Pass, 100% Bond Fiber Failure

LIMITATIONS

Store and apply between 40°F (4°C) and 100°F (38°), protect from freezing until dry.

Not suggested for sealing vapor barrier jackets.

Overhead applications may require mechanical fasteners.

H. B. Fuller Construction Products Inc.

1105 South Frontenac Street • Aurora, IL 60504 • 800-832-9002 • fax 800-952-2368

APPLICATION GUIDE FOR FOSTER LINE-FAS™ ADHESIVE 85-00

MATERIAL PREPARATION

DO NOT THIN. Apply only to clean, dry, oil free surfaces. Keep container closed when not in use. Before using for the first time, existing systems must be completely cleaned and free of the old adhesive and solvents. Corrosion resistant pumps and fittings are suggested.

APPLICATION

Apply LINE-FAS Adhesive to the metal surface uniformly at 400-500 ft²/gal (9.8-12.3 m²/l). While still wet, press the insulation into place, making sure that complete contact is made with applied adhesive.

SPRAY

The following equipment combinations are suggested:

	MODEL SPRAYGUN	FLUID NOZZLE	AIR CAP	FLUID PRESSURE	ATOMIZATION PRESSURE
Binks	2001SS	68SS	68PB	25psi	60psi
DeVilbiss	JGA-510	E	777	25psi	60psi

Airless, Electric, 30:1 or equivalent. Tip .019 - .025. Average viscosity range: 3,000 to 5,000 cps. All adhesive systems should have a fluid filter, of at least a 50-mesh size, at the pump, inline, or at the gun.

ROLLCOATERS, COIL LINES, AND DUCT LINER MACHINES

Use clean equipment suitable for water-base adhesives. Adjust equipment to apply the smallest amount of adhesive that will produce satisfactory bonds. On rollcoaters, protect the adhesive from exposure to the air as much as possible. Cover the trough and roller with plastic sheeting when not in use. In dry conditions, occasionally mist the surface of the adhesive with clean water to prevent skinning.

CLEAN-UP

To clean up, use hot soapy water if still wet. When dry, use xylene (flammable) or chlorinated solvent (non-flammable).

	ADHESIVES	
	SURFACE BURNING CHARACTERISTICS	
Applied to Inorganic Reinforced Cement Board		
Flame Spread:		5
Smoke Developed:		0
Tested as applied at a coverage rate of 400 ft ² /gal		
312U		

CUSTOMER SERVICE: 800-832-9002

IMPORTANT: H.B. Fuller Construction Products Inc. warrants that each of its products will be manufactured in accordance with the specifications in effect on the date of manufacture. WE MAKE NO OTHER WARRANTIES AND EXPRESSLY DISCLAIM ANY WARRANTIES OF MERCHANTABILITY OR FITNESS FOR A PARTICULAR PURPOSE. If a product fails to meet this limited warranty, purchaser's sole and exclusive remedy is replacement of the product or, at our option, refund of the purchase price. OUR ACCEPTANCE OF ANY ORDERS FOR THE PRODUCT IS EXPRESSLY CONDITIONAL UPON PURCHASER'S ASSENT TO THE TERMS ON THE APPLICABLE INVOICE.

ADEQUATE TESTS: The information contained herein we believe is correct to the best of our knowledge and tests. The recommendations and suggestions herein are made without guarantee or representation as to results. We recommend that adequate tests be performed by you to determine if this product meets all of your requirements. The warranted shelf life of our products is six months from date of shipment to the original purchaser.

For professional use only. Keep out of reach of children.
Consult Material Safety Data Sheet and container label for further information.

SUBMITTAL RECORD _____
 JOB _____
 LOCATION _____
 SUBMITTED TO _____
 SUBMITTAL PREPARED BY _____
 APPROVED BY _____
 DATE _____



Submittal Form DDIF Insulation Fastener

- WELDED FASTENERS -

DESCRIPTION: When liner is placed inside air conditioning or heating duct work, the movement of air could cause the insulation to delaminate. To prevent this, SMACNA Specifications call for the use of fasteners in addition to adhesive to secure the liner.

The fasteners may be of three types:

A. ADHESIVE: This fastener is bonded to the ductwork with an appropriate adhesive and allowed to set up. After sufficient drying time the liner is impaled on the pin and a washer added to retain the liner.

B. MECHANICAL: This type of fastener mechanically attaches itself to the duct work. The most popular style is a hardened nail with an attached washer. This fastener is impact driven through the liner and forms a positive mechanical grip with the metal.

C. WELD: This fastener forms a permanent bond to the duct work by becoming part of it as in any weld. Two styles are currently in use. The first fastener is a mechanical fastener which is driven through the liner and welded to the duct work underneath. The second fastener is a pin which is welded to the duct work prior to the insulation. The liner is then impaled (much like the adhesive fastener) over the pin and secured by a washer.

SPECIFICATIONS

All Duro Dyne Insulation Fasteners are designed to meet SMACNA HVAC Duct Construction Standard for Mechanical Fasteners.

All steel used in Duro Dyne Insulation Fasteners meets ASTM-A591.

All dimensions used in pin length are from bottom of head or base of fastener.

ALL PINS AND WASHERS ARE ZINC PLATED CRS UNLESS OTHERWISE STATED.

- MECHANICAL FASTENERS -

TBG Tripod Bangers®

Pin: .136" Diameter
 Washer: Diameter - 1.0"
 Thickness: - .015"



Item#	Bulk#	Code/Bulk Code	Approx. Length		Use
			Before Setting	After Setting	
26129	26133	TBG12/TBGB12	.475	.375	1/2" insulation
26130	26134	TBG100/TBGB100	.625	.525	1" 1-2# density
26181	26183	TBG118/TBGB118	1.250	1.150	1" 1 1/2# density

BGT Bangers®

Pin: .136" Diameter
 Washer: Diameter - 1.0"
 Thickness: - .015"



Item#	Bulk#	Code/Bulk Code	Approx. Length		Use
			Before Setting	After Setting	
26033	26095	BGT12/BGB12	.475	.375	1/2" insulation
26044	26096	BGT100/BGB100	.625	.525	1" 1-2# density

- SPOTTER PINS -

PN Pins

Pin Diameter: 14 Gauge Galvanized



Item#	Bulk#	Code/Bulk Code	Approx Pin Length		Use
			Before Setting	After Setting	
26001	26005	PN34/PNB34	.75		1/2" insulation
26002	26006	PN114/PNB114	1.25		1" insulation
26003	26007	PN200/PNB200	2.0		1 1/2" - 2" insulation
26004	26008	PN250/PNB250	2.5		2" - 3" insulation

LN Pins

Pin Diameter: 16 Gauge Galvanized



Item#	Bulk#	Code/Bulk Code	Approx Pin Length		Use
			Before Setting	After Setting	
26149	26153	LN34/LNB34	.75		1/2" insulation
26148	26154	LN150/LNB150	1.5		1" insulation
26147	26155	LN250/LNB250	2.5		1 1/2" - 2" insulation
26150	n/a	LN350/n/a	3.5		2" - 3" insulation
26151	n/a	LN450/n/a	4.5		3" - 4" insulation
26152	n/a	LN550/n/a	5.5		4" - 5" insulation

SSP Gold Seal Pins

Pin: .130 Diameter
 Washer: Diameter - 1.0"
 Thickness: - .015" - .017"
 Washer Adhesive: Petaflex Pressure Sensitive Adhesive



Item#	Bulk#	Code/Bulk Code	Nominal Length		Use
			After Setting	Before Setting	
26197	26297	SSP12/SSPB12	.365		1/2" insulation
26194	26294	SSP34/SSPB34	.531		1" 1-2# density
26195	26295	SSP100/SSPB100	.781		1" 2-3# density
26199	26293	SSP1F/SSPB1F	.905		1" Foam Insulation
26188	26299	SSP118/SSPB118	1.000		2-3# density
26189	26300	SSP150/SSPB150	1.365		1 1/2" insulation
26196	26296	SSP200/SSPB200	1.78		2" insulation
26190	26191	SSP218/SSPB218			2" HD insulation
26303	n/a	SSP300/n/a			3" insulation
26304	n/a	SSP400/n/a			4" insulation

CP Rib Pins®

Pin: .15" Diameter
 Washer: Diameter - 1.0"
 Thickness: - .015" - .017"



Item#	Bulk#	Code/Bulk Code	Nominal Length		Use
			After Setting	Before Setting	
26023	26028	CP12/CPB12	.365		1/2" insulation
26024	26029	CP34/CPB34	.531		1" 1-2# density
26025	26030	CP100/CPB100	.781		1" 2-3# density
26032	26035	CP118/CPB118	1.000		1" 3# + density
26026	26031	CP150/CPB150	1.365		1 1/2" insulation
26027	26038	CP200/CPB200	1.781		2" insulation

FTC Econo-Point Pins

Pin: .130" Diameter
 Washer: Diameter - 1.0"
 Thickness: - .015" - .017"



Item#	Code	Nominal Length		Use
		After Setting	Before Setting	
26072	FTC12	.365		1/2" insulation
26073	FTC34	.531		1" 1-2# density
26074	FTC100	.781		1" 2-3# density
26131	FTC118	1.000		1" 3# density
26226	FTC150	1.365		1 1/2" insulation
26227	FTC200	1.781		2" insulation

BDEP Aerodynamic Target® Washer Weld Pins

Pin: .130" Diameter
 Washer: Diameter - 1.0"
 Thickness: - .015" - .017"



Item#	Bulk#	Code/Bulk Code	Nominal Length		Use
			After Setting	Before Setting	
22235	26220	TTAP12/BDEP12	.365		1/2" insulation
26236	26221	TTAP34/BDEP34	.531		1" 1-2# density
26237	26222	TTAP100/BDEP100	.781		1" 2-3# density
26238	26217	TTAP118/BDEP118	1.000		1" 3# density
26239	26218	TTAP150/BDEP150	1.365		1 1/2" insulation
26240	26219	TTAP200/BDEP200	1.781		2" insulation
26241	26216	TTAP218/BDEP218	2.00		2" HD insulation

CTC Sloped® Washer Weld Pins

Pin: .130" Diameter
 Washer: Diameter - 1.0"
 Thickness: - .015" - .017"



Item#	Code	Nominal Length		Use
		After Setting	Before Setting	
26228	CTC12	.365		1/2" insulation
26229	CTC34	.531		1" 1-2# density
26230	CTC100	.781		1" 2-3# density
26231	CTC118	1.000		1" 3# density
26232	CTC150	1.365		1 1/2" insulation
26233	CTC200	1.781		2" insulation

- ADHESIVE FASTENERS -

SAH

Self Adhesive Hangers with Washer

Pin: min. 12 Gauge Zinc Plated

Base dimension: 2" x 2" galvanized 28 Gauge steel

Adhesive: Polyethylene foam impregnated with rubber based adhesive.



Item#	Bulk#	Code/Bulk Code	Approx Length	Use
26067	26036	SAH34/SAHB34	.75	1/2" insulation
26068	26037	SAH114/SAHB114	1.25	1" insulation
26069	26040	SAH134/SAHB134	1.75	1 1/2" - 1 1/2# density
26070	26041	SAH200/SAHB200	2.00	1 1/2" - 2# + density
26071	26047	SAH250/SAHB250	2.5	2" insulation
n/a	26126	n/a/SAHB350	3.5	3" insulation
n/a	26127	n/a/SAHB450	4.5	4" insulation

STIK-TAC™

Self Adhesive Hangers with Washer

Pin: min. 12 Gauge Zinc Chromate

Base dimension: 1 3/8" x 1 3/8" galvanized 28 Gauge steel

Adhesive: Polyethylene foam impregnated with rubber based adhesive.

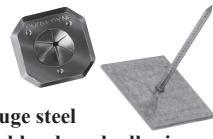

Item#	Code	Approx Length	Use
26192	STK134B	1.75	1 1/2" - 1 1/2# density
26193	STK250B	2.5	2" insulation

FLIP-STIX®

Self Adhesive Hangers with Washer

Galvanized - 24 Gauge

Aluminum - .032 nominal Type 5052-H34

Stainless Steel - 24 Gauge Type 301

Adhesive: Polyethylene foam impregnated with rubber base adhesive.



Item#	Code	Approx Length	Use
26055	FSG-250 Galvanized	2.5	1/2" to 2" insulation
26056	FSA-250 Aluminum	2.5	1/2" to 2" insulation
26057	FSS-250 Stainless Steel	2.5	1/2" to 2" insulation
26061	FSG-E Galvanized Extension	5.752	1/2" to 5" insulation
26054	FSA-E Aluminum Extension	5.75	2 1/2" to 5" insulation
26063	FSS-E Stainless Steel Extension	5.75	2 1/2" to 5" insulation

PBH

Perforated Base Adhesive Hangers with Washer

Pin: min. 12 Gauge Zinc Plated

Base dimension: 2" x 2" 28 Gauge Galvanized.

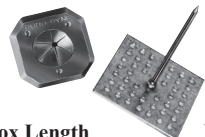

Item#	Bulk#	Code/Bulk Code	Approx Length	Use
26075	26097	PBH34/PBHB34	.75	1/2" insulation
26076	26098	PBH114/PBHB114	1.25	1" insulation
26077	26099	PBH134/PBHB134	1.75	1 1/2" - 1 1/2# density
26078	26100	PBH200/PBHB200	2.00	1 1/2" - 2# + density
26079	26101	PBH250/PBHB250	2.5	2" insulation
n/a	26128	n/a/PBHB350	3.5	3" insulation
n/a	26112	n/a/PBHB450	4.5	4" insulation



- WASHERS FOR SPOTTER PINS -

Item#	Bulk#	Code/Bulk Code	Area
26017	26019	PC1/PCBI - for use w/PN (30 gauge galvanized)	1 1/4" x 1 1/4"
26145	26146	LC1/LCBI - for use w/LN (30 gauge galvanized)	1 1/4" x 1 1/4"
26115	26093	LPC-1/LPC-IB - for use w/SAH, PBH & Stick-Tac	1 1/4" x 1 1/4"
26051	n/a	FSW-A for use w/Flipstix (aluminum)	1 1/4" x 1 1/4"
26050	n/a	FSW-G for use w/Flipstix (galvanized)	1 1/4" x 1 1/4"
26052	n/a	FSW-S for use w/Flipstix (stainless)	1 1/4" x 1 1/4"

- DUCT LINER INSTALLATION -

METAL NOSING MUST BE USED WHEREVER LINER IS PRECEDED BY UNLINED METAL; OTHERWISE WHEN VELOCITY EXCEEDS 4000 FPM (20.3 MPS) USE METAL NOSING ON EVERY LEADING EDGE. NOSING MAY BE FORMED ON DUCT OR BE CHANNEL OR ZEE ATTACHED BY SCREWS, RIVETS OR WELDS.

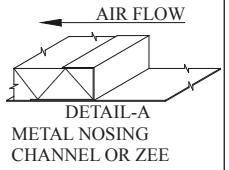

INTERIOR WIDTH OF 8" (200 mm) AND LESS DOES NOT REQUIRE PINS

LAPPED AND BUTTED CORNER.

PLACE PINS 3" (76 mm) ALONG EACH SIDE OF A BUTTED LONGITUDINAL LINER SEAM THAT IS AWAY FROM A CORNER

THE VELOCITY RATED SIDE OF LINER MUST FACE THE AIR FLOW.

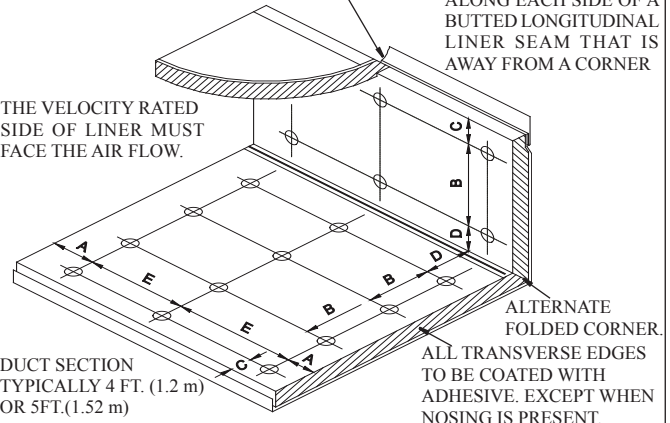

DUCT SECTION TYPICALLY 4 FT. (1.2 m) OR 5 FT. (1.52 m)

ALTERNATE FOLDED CORNER. ALL TRANSVERSE EDGES TO BE COATED WITH ADHESIVE. EXCEPT WHEN NOSING IS PRESENT.

MAXIMUM SPACING FOR FASTENERS. ACTUAL INTERVALS ARE APPROXIMATE

LINER ADHERED TO THE DUCT WITH 90% MIN. AREA COVERAGE OF ADHESIVE

"A" PIN ROW MAY BE OMITTED WHEN METAL NOSING IS USED. "E" THEN STARTS FROM THE NOSING.

Velocity*	Dimensions				
	A	B	C	D	E
0-2500 FPM (0-12.7 MPS)	3" (76.2)	12" (305)	4" (102)	6" (152)	18" (457)
2501-6000 FPM (12.7-30.5 MPS)	3" (76.2)	6" (152)	4" (102)	6" (152)	16" (406)

*UNLESS A LOWER LEVEL IS SET BY MANUFACTURER OR LISTING AGENCY

- LINER FASTENERS -

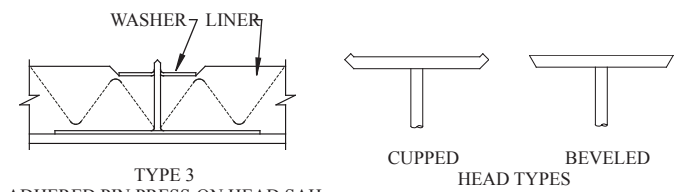
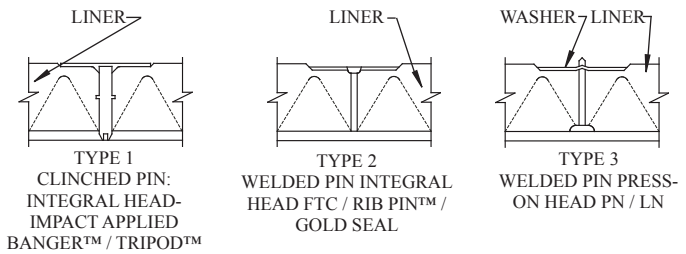

INSTALLED PINS AND WASHERS SHALL NOT COMPRESS LINER MORE THAN THE CORRECT LENGTH SPECIFIED FOR THE LINER THICKNESS USED.

SUGGESTED SPECIFICATIONS

All duct liner shall be secured to the duct work in accordance with SMACNA HVAC Duct Construction Standards. Fasteners shall be _____ (mechanical, adhesive, weld) type Fastener Code _____ as manufactured by Duro Dyne Corporation, Bay Shore, N.Y. Washers, when necessary, shall be Code _____ as manufactured by Duro Dyne Corporation, Bay Shore, N.Y.

Duro Dyne East Division, Bay Shore, NY
 Duro Dyne Midwest Division, Fairfield, OH
 Duro Dyne West Division, Fontana, CA
 Duro Dyne Canada, Lachine, Quebec, Canada

631-249-9000 Fax: 631-249-8346
 513-870-6000 Fax: 513-870-6005
 562-926-1774 Fax: 562-926-5778
 514-422-9760 Fax: 514-636-0328

www.durodyne.com E-mail: durodyne@durodyne.com



©2015 Duro Dyne Corporation
 Printed in USA 7/13/15
 B0026402

TURNING VANES- THIS SECTION WILL DETAIL TYPES OF TURNING VANES FABRICATED BY SHEETMETAL SHOP.

AIRCO DOUBLE

DOUBLE VANE SCHEDULE

	RAD.	SPACE	GA.
* SMALL-----	2"	2-1/8"	26
* LARGE-----	4-1/2"	3-1/4"	24

*INSTALL EVERY OTHER VANE

SMACNA DOUBLE

DOUBLE VANE SCHEDULE

	RAD.	SPACE	GA.
SMALL-----	2"	2-1/2"	26
LARGE-----	4-1/2"	3-1/2"	18

NOTE: USE SMALL VANES ON DUCTS UP TO 18" WIDE AND USE LARGE VANES ON DUCTS LARGER THAN 19" WIDE.

PRODUCTS	PART #
VANES	SMALL 360001
	LARGE 360003
RAIL	SMALL 360002
	LARGE 360004

SUBMITTAL RECORD

JOB _____
 LOCATION _____
 SUBMITTED TO _____
 SUBMITTAL PREPARED BY _____
 APPROVED BY _____
 DATE _____



**Submittal Form
 VANE AND RAIL**

DESCRIPTION

Hollow Turning Vane and Vane Rail are designed to redirect the air through elbows and tees in the ductwork without significant loss of air pressure. Assembled Vane & Rail minimizes turbulence in the ductwork.

FEATURES

- Hollow Turning Vane and Vane Rail are designed to redirect the air through elbows and tees in the ductwork without significant loss of air pressure. Assembled Vane & Rail minimizes turbulence in the ductwork.
- Duro Rail has self aligning tabs for easy vane installation.
- 2in. Turning Vane are manufactured from 26-gauge galvanized steel.
- 4in. Turning Vane are manufactured from 24-gauge galvanized steel.
- 2in. and 4in. Vane Rail are manufactured from 24 or 22-gauge galvanized steel.
- All Rail described on this page is a Duro Dyne version of Runner Type 1 as described in Smacna (see drawing below).

2" Vane & Rail



4" Vane & Rail



Hollow Turning Vane

Item #	Code	Description	Packaging	Weight (lbs.)	Master Skid Qty.
13203	HTV2-2610	26ga. 2in. Turning Vane 10ft.	5-10ft. pcs./Bundle	24	7200ft.
13220	HTV2-10AL	Alum. 2in. Turning Vane 10ft.	5-10ft. pcs./Bundle	13	7200ft.
13224	HTV2-10SS	Stainless 2in. Turning Vane 10ft.	5-10ft. pcs./Bundle	26	7200ft.
13207	HTV4-2410	24ga. 4in. Turning Vane 10ft.	5-10ft. pcs./Bundle	55	2500ft.
13222	HTV4-10AL	Alum. 4in. Turning Vane 10ft.	5-10ft. pcs./Bundle	33	2500ft.
13226	HTV4-10SS	Stainless 4in. Turning Vane 10ft.	5-10ft. pcs./Bundle	58	2500ft.

Vane Rail

Item #	Code	Description	Packaging	Weight (lbs.)	Master Skid Qty.
13300	DHVR2-	2in. Vane Rail 10ft.	10-10ft. pcs./Bundle	46	4000ft.
13221	HVR2-10AL	Alum. 2in. Vane Rail 10ft.	10-10ft. pcs./Bundle	18	6000ft.
13225	HVR2-10SS	Stainless 2in. Vane Rail 10ft.	10-10ft. pcs./Bundle	30	6000ft.
13302	DHVR4-	4in. Vane Rail 10ft.	10-10ft. pcs./Bundle	71	2000ft.
13223	HVR4-10AL	Alum. 4in. Vane Rail 10ft.	10-10ft. pcs./Bundle	36	2000ft.
13227	HVR4-10SS	Stainless 4in. Vane Rail 10ft.	10-10ft. pcs./Bundle	59	2000ft.

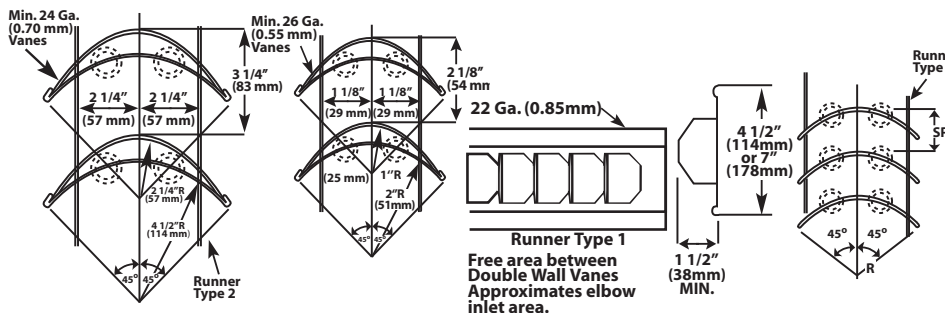

Single Vane Schedule			
	R	SP	GA
Small	2"	1 1/2"	24
	(51mm)	(38mm)	(0.70mm)
Large	4 1/2"	3 1/4"	22
	(114mm)	(83mm)	(0.85mm)

See notes on fig.2-4. Other runners may be used as appropriate. Other vane sizes, spacings or configurations are acceptable on designer approval.

As Described on page 2.5, Figure 2-3 of the SMACNA HVAC Duct Construction Standards, 2nd Ed., 1995.



Duro Dyne East Division, Bay Shore, NY
 Duro Dyne Midwest Division, Fairfield, OH
 Duro Dyne West Division, Fontana, CA
 Duro Dyne Canada, Lachine, Quebec, Canada

631-249-9000 Fax: 631-249-8346
 513-870-6000 Fax: 513-870-6005
 562-926-1774 Fax: 562-926-5778
 514-422-9760 Fax: 514-636-0328

www.durodyne.com E-mail: durodyne@durodyne.com



©2013 Duro Dyne Corporation
 Printed in USA 6/13
 BO050003

Vane Rail

Duro Dyne Vane Rail, made up of 24 gauge galvanized steel, is precision-stamped and slotted assuring uniform spacing of vanes, and the fastest, easiest, most economical construction of vane assemblies. Duro Dyne Vane Rail is specially embossed adding strength and sturdiness to the finished section, eliminating rattling. Vane Rail can be used to make quality turning vanes for any size elbow including change of size elbows.

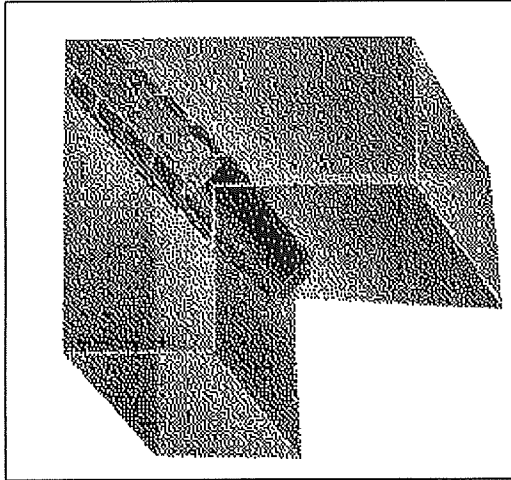

system, therefore air turning vane assemblies are used to guide air evenly around such turns. With today's high labor costs, it is expensive for shops to produce their own air turning assemblies. That is why Duro Dyne Vane Rail is a major contribution to sheet metal shops that require efficient, yet inexpensive air turning assemblies. With Duro Vane Rail, which is a pre-fab side rail, layout time is eliminated. Vanes can be sheared

Air travelling throughout a duct is slowed up when it reaches a right turn angle. This "slow-up" is detrimental to the efficiency of the duct

from scrap metal without tab cutting, and quickly assembled to rails with only one blow of a ball peen hammer.

Specifications and Ordering

Item#	Code:	Description:
4002	VR-2	Vane Rail - 100 ft. Continuous Coils
4003	JVR-2	Junior Vane Rail - Two 100 ft. Continous Coils (Easily Dispensed Together or Singularly)

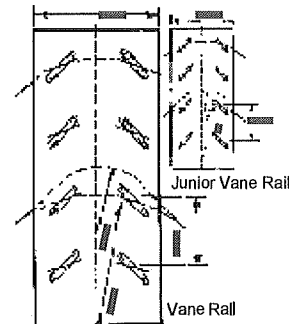

Fabricating Air Turning Vanes

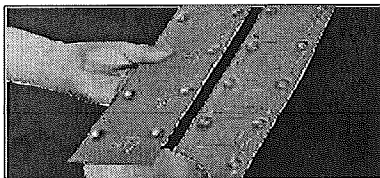

Shear and form vanes as indicated. Position vanes in Vane Rail slot. Slots force vanes to take correct curve.

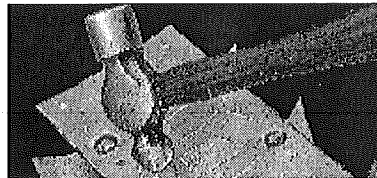

Secure the protruding vane with ball peen hammer.

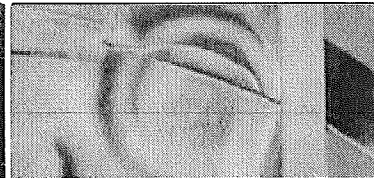

Extra deep depression in Vane Rail allow for superior gripping action. Vane assembly is then fastened in elbow.

Duro Dyne National Corp., 81 Spence St., Bay Shore, NY 11706
 Duro Dyne East Corp., 81 Spence St. Bay Shore, NY 11706
 Duro Dyne West Corp., 15005 Marquardt Ave. Santa Fe Springs, CA 90670
 Duro Dyne Midwest Corp., 3825 Symmes Rd., Fairfield, OH 45011
 Duro Dyne Canada Inc., Lachine, Quebec H8T1B3
 Duro Dyne International Division, Bay Shore, NY 11706

Phone: 631-249-9000
 Phone: 631-249-9000
 Phone: 562-926-1774
 Phone: 513-870-6000
 Phone: 514-422-9760
 Phone: 631-249-9000

Fax: 631-249-8346
 Fax: 631-249-8346
 Fax: 562-926-5778
 Fax: 513-870-6005
 Fax: 514-636-0328
 Fax: 631-249-8346

© 2003 Duro Dyne Corp.
 Printed in USA 9/2003
 BB010400

Sheet Metal Connectors Inc. Product Specifications

HOME

PRODUCTS

INFO

PROFILE

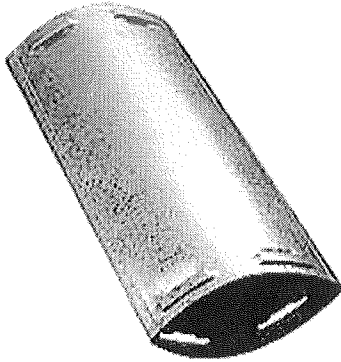

Single-Wall Turning Vanes

Made of .029 (+ or -.003) G-60 or better galvanized steel. Each is packaged in 10-foot lengths, ten pieces per bundle. Turning vanes have a 4" -4 1/2" radius.

Typical radius for single-wall turning vane.

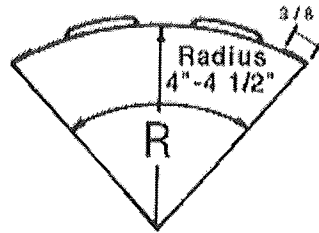

U.S. Pat. No 4,911,205

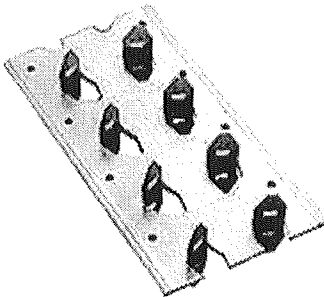

EZ - RAIL II

Snap Lock Side Rail

Made of .029 (+or-.003) G-60 or better galvanized steel. Each is packaged in 10-foot lengths, ten pieces per carton. Rail measure 6.75" wide, and the optimum spacing between vanes is 3.25" center to center.

Extra long tabs and self locking buttons add strength while permanently fastening vane and rail together. The aerodynamic quality of single-wall turning vanes eliminates excessive pressure loss. (In agreement with SMACNA-sponsored research.)

Successfully tested at up to ~2500fpm airflow velocity. (Research by ETL Testing Laboratories, Inc. available upon request.)

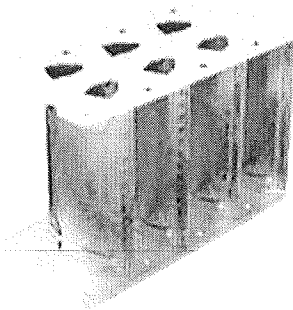

Sheet Metal Connectors Inc.
5850 Main Street N.E.
Minneapolis, MN 55432
PHONE 1-800-328-1966
FAX 1-763-572-1100
EMAIL sales@smcduct.com



FABRICATION ABBREVIATIONS

PRODUCT- DURO/DYNE #CGN150

150 FOOT ROLL

PART # 360010

TYPE	ABBREVIATION	STREAK
OUT		
STANDARD "S" AND DRIVE	SD	1/2"
DUCTBOARD	DB	0"
HEM	HM	1/2"
INSIDE FLANGE	INF	1"
OUTSIDE FLANGE	OSF	1"
OUTSIDE TAP	OST	2-3/4"
INSIDE TAP	ISF	2"
DUCTBOARD TAP	DBT	4"
DUCTMATE	DM	0
RAW	RR	0

SEAMS- THIS SECTION WILL DETAIL FABRICATION STANDARDS USED BY AIRCO FOR DIFFERENT TYPES OF SEAMS.

<u>TYPE</u>		<u>STRETCH OUT</u>
SNAP LOCK		1-3/8" / 1/2"
PITTSBURGH	SMALL	1" / 1/4"
	LARGE	1-3/8" / 1/2"

SUBMITTAL RECORD

JOB _____
 LOCATION _____
 SUBMITTED TO _____
 SUBMITTAL PREPARED BY _____
 APPROVED BY _____
 DATE _____



Submittal Form
DDFDC
Flexible Duct Connector

DESCRIPTION

All air duct installations for heating, cooling or ventilation are attached to mechanical equipment containing a fan or blower. Vibrations, noises and rattles resulting from operation of the fan or blower are transmitted into the metal ducts which carry the noises throughout the system.

In order to isolate the vibration and noises to the source, an air-tight flexible joint, consisting of a fabric which is attached to sheet metal on both side, must be inserted between the equipment and the ductwork. This vibration isolator is called a "Flexible Duct Connector".

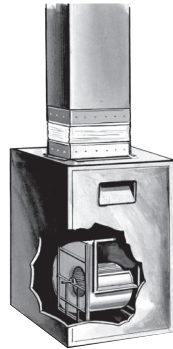

RELATED NFPA 90A & 90B STANDARDS

2-3.2.2 Vibration isolation connectors in duct systems shall be made of an approved flame-retardant fabric or shall consist of sleeve joints with packing of approved material, each having a maximum flame spread index of 25 and a maximum smoke developed index of 50. Exception: Approved flame-retardant fabric having a maximum length of 10 in. (25.4 cm) in the direction of airflow-NFPA No. 90A 1999

2-1.1.1 Exception No. 3: Vibration isolation connectors in duct systems shall be made of approved flame-retardant fabric or shall consist of sleeve joints with packing of approved noncombustible material. The fabric shall not exceed 10 in. (254 mm) in length in direction of airflow-NFPA No. 90B 1999

FABRIC COMPARISONS	Excelon ⁵	Neoprene	Durolon	Insulflex*	Thermafab [®]	Teflon	Glasseal
UL Classified File #	R4462	R4462	R4462	n/a	R4462	n/a	R4462
Continuous Temp. Range	-40°F. to 180°F.	-40°F. to 200°F.	-40°F. to 250°F.	-40°F. to 180°F.	-65°F. to 500°F.	-150°F. to 500°F.	-40°F. - 180°F.
Color	Black	Black	White	Black	Grey	Grey Outside/ Beige Inside	Grey & Black
Weight Per Square Yard	22	30	26	28 (composite weight)	17	16.5	16
Abrasion Resistance ¹	15,000 cycles	600 cycles	500 cycles	500 cycles	125 cycles	1,000 cycles	1,400 cycles
Leakage Resistance ²	350	595	250	125	400	650	120
Tear Strength ³	100/100	12/12	12/12	8/11	50/40	50/30	8/9
Tensile Strength ⁴	240/220	500/450	225/300	70/70	200/150	400/300	90/90
Base Fabric	Woven Nylon/ Polyester Blend	Woven Fiberglass	Woven Fiberglass	Polyester	Woven Fiberglass	Fiberglass/ Satin Weave	Woven Fiberglass
Coating	Vinyl	Neoprene	Hypalon	Vinyl	Silicon Rubber	Teflon	Vinyl
Features	High Tear Strength High Abrasion Resistance	General Purpose	Excellent Ozone and Weathering Resistance Best Overall Acid Resistance Recommended for rooftop applications Unaffected by mildew	Low Smoke Emission Insulated 3-4-3 Configuration	Very Low Smoke Emission High Temperature Resistant	High Temperature Resistant High Corrosion Resistance Excellent Chemical Resistance	Resistant to Acids & Chemical Fumes Resistant to Grease & Alkalies Unaffected By Mildew
Codes							
Metal-Fab 3x3x3 Grip Loc	MBX333 (#10159) MSPX333 (#10263)	MFN333 (#10003)	MFD333 (#10002)	IDC343 (#10173) *Gauge: 28 +Guard Loc	MFT333 (#10005)	MCT333 (#10278)	MGL333 (#10004)
Super Metal-Fab 3x6x3 Grip Loc	MB6X363 (#10160) MSP6X363 (#10265)	MF6N363 (#10012)	MF6D363 (#10011)	Not Available	MF6T363 (#10013)	Not Available	MF6G363 (#10016)
TDC/TDF 4x4x4 Grip Loc	MBX444 (#10210) MSPX444 (#10264) MBX464 (#10214)	MFN444 (#10211) MFN464 (#10246)	MFD444 (#10237) MFD464 (#10245)	Not Available	Not Available	MCT444 (#10279)	Not Available

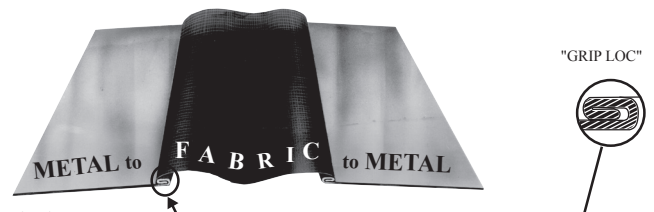

All Metal-Fab, Super Metal-Fab and TDC/TDF Flexible Duct Connectors are manufactured with 24 gauge galvanized steel. Other materials are available upon request. Stainless Steel configurations utilize 304 or 316 grade material.

Notes:

1. Abrasion resistance as per Federal Test Standard 191 Method #5306 using CS 17 wheel with 250 Gram load.
2. Leakage resistance as per Federal Test Standard 191 Method #5512. Results in P.S.I. (To convert inches of water multiply P.S.I. x 27.176.)
3. Tear strength in tongue pounds as per Federal Test Standard 191 Method #5134.1 (warp/fill).
4. Tensile strength in grab pounds as per Federal Test Standard 191 Method #5100 (warp/fill).
5. Standard Excelon is not LA city approved. Use Excelon-LA when LA city approval is necessary. (See Specification Form Excelon-LA - 203)

All Duro Dyne Flexible Duct Connector Products are suitable for pressures of -10 to +15 wg. Duro Dyne's standard 'single fold' metal to fabric grip has been tested by an independent testing laboratory to withstand a negative pressure of -10" WC and a positive pressure of +17.25" WC with no tearing or visible separation.

SUGGESTED SPECIFICATION

Vibration Isolating Flexible Duct Connector For Heating, Cooling & Exhaust Supplies & Returns.

At the inlet and discharge of all air handling equipment(unless otherwise noted) furnish and install vibration isolators. Vibration isolators shall be a coated woven fabric named _____ and shall be "Underwriters Laboratories Classified".

Vibration isolators shall have a tear strength of not less than _____, and a continuous temperature range of _____. Vibration isolators shall be preassembled metal to exposed fabric to metal. Fabric and metal shall be joined by means of a double lock seam.

Vibration isolators shall be code _____ (called Flexible Duct Connectors) as manufactured by Duro Dyne Corporation, Bay Shore, N.Y.

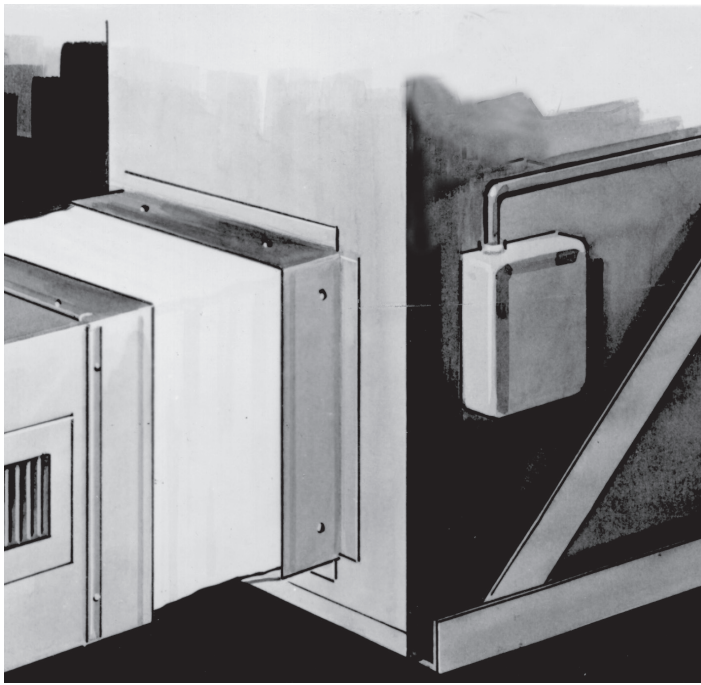

DURO DYNE[®]

Specifications

All Listed Duro Dyne Flexible Duct Connector Fabrics are designed to meet the following specifications:

1. MIL-C-20696B Para. 4.4.3. (Oil Resistance).
2. MIL-C-20696B Para. 4.4.4. (Hydro Carbon Resistance).
3. NFPA 90A Installation of Air Conditioning and Ventilating Systems Para. 4.3.2.2 2012 Edition.
4. NFPA 90B Warm air heating and air conditioning systems. Para. 4.1.1.1.3.1 2012 Edition. (*See note 1 below)
5. NFPA701 Tests for Flame Propagation of Fabrics and film.
6. California State Fire Marshal Approved.
7. Los Angeles City Approved. (*See note 2 below)
8. Denver City Approved.

All Duro Dyne Flexible Duct Connectors utilize galvanized steel meeting ASTM-A-525 G 60 or better.

Duro Dyne Flexible Duct Connectors are also available with 300 series stainless steel or 3003 aluminum upon request.

*Note 1 - Standard Excelcon does not currently meet NFPA 90B 2012 but does meet all previous editions. Use Excelcon-LA if NFPA 90B 2012 approval is necessary.

**Note 2 - Standard Excelcon is not LA city approved. Use Excelcon-LA when LA city approval is necessary. (See Submittal Form for Excelcon-LA)

CHEMICAL RESISTANCE

(X = Extremely Resistant)

(NR = Not Recommended)

(O = No Data Available)

Chemical	Excelcon							Chemical	Excelcon						
	Neoprene	Durolon	Insulflex	Thermafab	Teflon	Glassteel	Neoprene		Durolon	Insulflex	Thermafab	Teflon	Glassteel		
Acetic Acid	NR	X	X	NR	NR	X	NR	Hydrofluoric Acid (100%)	NR	X	X	NR	NR	X	NR
Aluminum Chloride	X	X	X	X	X	X	X	Hydrogen Peroxide	X	NR	X	X	X	X	X
Aluminum Sulfate	X	X	X	X	X	X	X	Hydrogen Sulfide	X	X	X	X	O	X	X
Ammonia (Anhyd)	X	X	X	X	X	X	X	Lactic Acid	NR	X	X	NR	O	X	NR
Ammonium Hydroxide	X	X	X	X	X	X	X	Linseed Oil	NR	X	X	NR	X	O	NR
Ammonium Sulfate	X	X	X	X	X	X	X	Magnesium Chloride	NR	X	X	NR	NR	X	NR
Barium Sulfide	X	X	X	X	O	X	X	Maleic Acid	X	NR	X	X	X	O	X
Black Sulfate Liquor	X	X	X	X	NR	X	X	Methyl Alcohol	NR	X	X	NR	NR	X	NR
Boric Acid	X	X	X	X	X	X	X	Methyl Cellosolve	NR	X	X	NR	NR	O	NR
Butyl Alcohol	NR	X	X	NR	NR	X	NR	Mineral Oil	X	X	X	X	NR	X	X
Cadmium Plating Solution	X	NR	NR	NR	O	O	X	Naptha	NR	NR	NR	NR	X	X	NR
Calcium Chloride	X	X	X	X	X	X	X	Nickel Chloride	X	X	X	X	O	X	X
Calcium Hypochlorite	X	NR	X	X	O	X	X	Nickel Sulfate	X	X	X	X	X	X	X
Chlorine Water	X	NR	NR	X	NR	O	X	Nitric Acid (40%)	X	NR	X	X	NR	X	X
Chromic Acid	X	NR	X	X	O	X	X	Oleic Acid	X	NR	NR	X	NR	X	X
Chromium Plating Solution	X	O	O	NR	O	O	X	Oleum	NR	NR	X	NR	O	X	NR
Citric Acid	X	X	X	X	X	X	X	Oxalic Acid	X	X	X	X	X	X	X
Copper Chloride	X	X	X	X	O	X	X	Phosphoric Acid (85%)	NR	X	X	NR	X	X	NR
Copper Sulfate	X	X	X	X	O	X	X	Pickling Solution	X	NR	X	X	O	O	X
Cottonseed Oil	X	X	X	X	X	O	X	Potassium Chloride	X	X	X	X	O	O	X
Diacetone Alcohol	NR	X	X	NR	O	O	NR	Potassium Cyanide	X	X	X	X	O	X	X
Disodium Phosphate	X	NR	NR	X	O	O	X	Potassium Dichromate	X	X	X	X	O	X	X
Ethyl Alcohol	NR	X	X	NR	NR	X	NR	Potassium Hydroxide (40%)	X	X	X	NR	X	X	X
Ethylene Glycol	NR	X	X	NR	X	X	NR	Potassium Sulfate	X	X	X	X	O	X	X
Ferric Chloride	X	X	X	X	X	X	X	Propyl Alcohol	NR	X	X	NR	NR	O	NR
Ferric Sulfate	X	X	X	X	X	X	X	Sodium Chloride	X	X	X	X	X	X	X
Fluoroboric Acid	X	X	X	NR	O	O	X	Sodium Hydroxide (40%)	NR	X	X	NR	X	X	NR
Formaldehyde (40%)	X	X	X	X	O	X	X	Sodium Hypochlorite	NR	NR	X	NR	NR	X	NR
Formic Acid	X	X	X	X	O	X	X	Steam	NR	X	NR	NR	O	X	NR
Glucose	X	X	X	X	X	X	X	Sulfur Dioxide (Liquid)	NR	X	X	NR	X	X	NR
Glycerine	NR	X	X	NR	X	X	NR	Sulfuric Acid (50%)	X	NR	X	NR	NR	X	X
Heptane	NR	X	X	NR	O	X	NR	Sulfuric Acid (over 50%)	NR	NR	X	NR	NR	X	NR
Hexane	NR	X	X	NR	O	X	NR	Tannic Acid	X	X	X	X	O	X	X
Hydrobromic Acid (40%)	NR	X	X	NR	O	X	NR	Vinegar	X	X	X	X	X	X	X
Hydrochloric Acid (conc)	NR	X	X	NR	NR	X	NR								

Duro Dyne East Division, Bay Shore, NY
 Duro Dyne Midwest Division, Fairfield, OH
 Duro Dyne West Division, Fontana, CA
 Duro Dyne Canada, Lachine, Quebec, Canada

631-249-9000 Fax: 631-249-8346
 513-870-6000 Fax: 513-870-6005
 562-926-1774 Fax: 562-926-5778
 514-422-9760 Fax: 514-636-0328

www.durodyne.com E-mail: durodyne@durodyne.com



©2015 Duro Dyne Corporation
 Printed in USA 10/15
 BO010403

DAMPERS- THIS SECTION WILL DETAIL FABRICATION STANDARDS FOR DAMPERS USED BY AIRCO.

SHOP FABRICATED DAMPER WILL ONLY BE MANUFACTURED UP TO 12" DEEP WITH 3/8" QUADRANT AND ROD. SEE DETAIL.

DURO DYNE

OPEN END BEARING

SP138

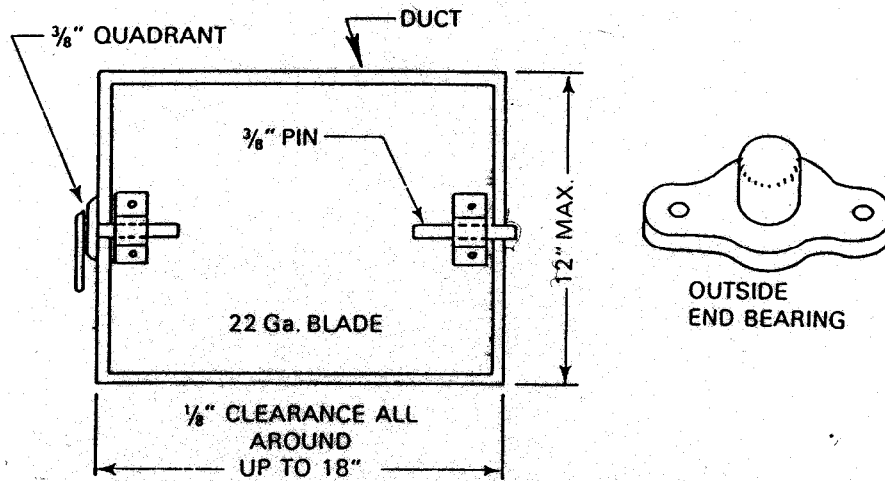

SMACNA STANDARD DUCT ACCESS DOORS SQUARE AND RECTANGULAR • INSULATED MODELS: 08SCL AND 08SH

MODEL DESCRIPTION:

These economical quality access doors meet SMACNA requirements and provide quick, simple installation wherever duct access is required. Available in 20 sizes to meet all access requirements. Camlock operation for positive seal and easy opening.

CONSTRUCTION DETAILS:

1. Die-formed 22 ga. (0.86) galvanized steel flanged frame for strength.
2. Die-formed double skin 22 ga. (0.86) galvanized door panel for extra strength.
3. 1" (25) insulation.
4. Notched knock-over tabs.
5. Plated steel camlock fasteners.
6. Positive seal polyethylene gasket.
7. Safety retaining chain standard on removable door Model 08SCL.
8. Continuous piano-type hinge standard on Model 08SH.
9. Removable door Model 08SCL is furnished with four camlocks on sizes over 14" (356) in width or height. Hinged door Model 08SH is furnished with two camlocks on sizes over 14" (356) in height.
10. Meet SMACNA construction specifications for systems up to 2" w.g. (500 Pa).

OPTIONS:

- F10 for 1" (25) fiberglass duct.
- F15 for 1 1/2" (32) fiberglass duct.
- HP High Pressure. Adds second gasket on underside of frame for frame to duct seal.

Manufactured by members of S.M.W.I.A.

NOMINAL SIZE		QUANTITY PER CARTON
6 x 6 (152 x 152)	*	10
8 x 8 (203 x 203)	*	10
10 x 8 (254 x 203)		10
10 x 10 (254 x 254)	*	10
12 x 10 (305 x 254)		10
12 x 12 (305 x 305)	*	10
14 x 10 (356 x 254)		10
14 x 12 (356 x 305)		10
14 x 14 (356 x 356)	*	10
16 x 12 (406 x 305)		5
16 x 14 (406 x 356)		5
16 x 16 (406 x 406)	*	5
18 x 12 (457 x 305)		5
18 x 14 (457 x 356)		5
18 x 16 (457 x 406)		5
18 x 18 (457 x 457)		5
20 x 16 (508 x 406)		5
20 x 20 (508 x 508)		5
24 x 18 (610 x 457)		5
24 x 24 (610 x 610)		5

* STOCK SIZES

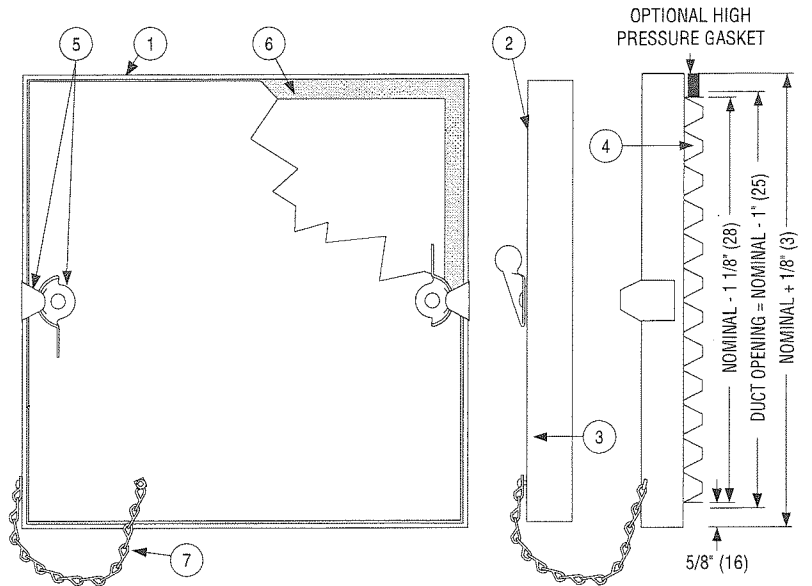

MODEL 08SCL REMOVABLE DOOR (PAIRED CAMLOCKS)

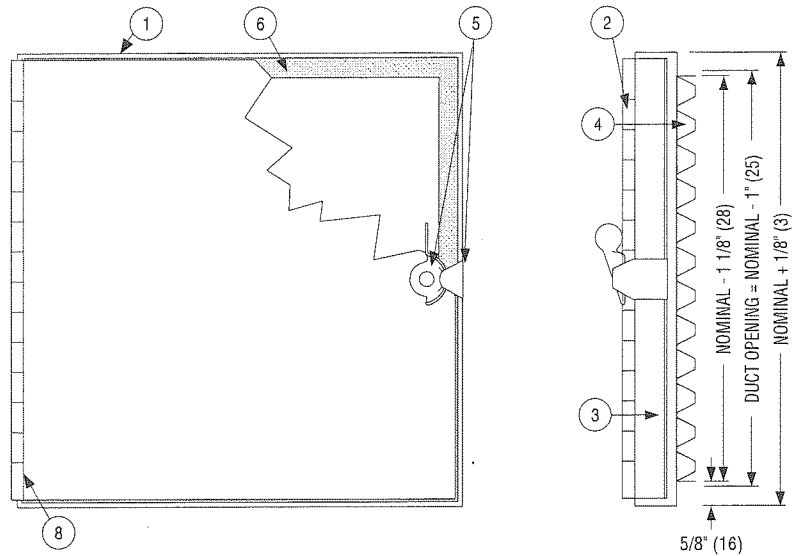

MODEL 08SH HINGED DOOR (WITH CAMLOCK CLOSURE)

FIBERGLASS DUCT OPTION

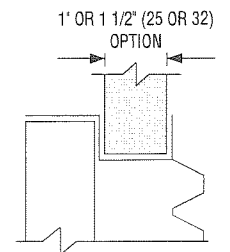

Dimensions are in inches (mm).

SCHEDULE TYPE:					
PROJECT:					
ENGINEER:	DATE	B SERIES	SUPERSEDES	DRAWING NO.	
CONTRACTOR:	29 - 2 - 00R	0800	7 - 12 - 98	0800-1S	



1000 South IH-35, Round Rock, TX 78681
Phone | 512-906-3963 • Fax | 512-837-3112 • www.aircomechanical.com

Sub-Section:

2) Low Pressure Duct, Flex & Misc Accessories

Spec Section Reference:

Airco Contact:

Phone:

Email:

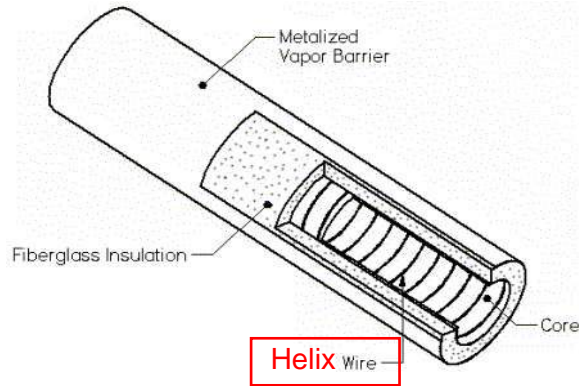

VAPOR BARRIER

- The Quietflex Rip Stop Gold Jacket Flex Duct has a metalized polyester-vapor barrier with a special "rip stop" scrim reinforcement.
- Vapor Transmission: at or below 0.05 perms

FIBERGLASS

- R6 and R8 certified by ETL and the Air Diffusion Council using ASTM C-518 at installed thickness of insulation
- Made of formaldehyde free materials

CORE

- Antimicrobial inner core constructed with two layers of film that encapsulate a galvanized wire helix
- Rated positive pressure is 10" W.C. and negative pressure is 1/2" W.C. per the **UL 181** standard
- Rated maximum air velocity is 6000 FPM

SURFACE BURNING CHARACTERISTICS

- Flame spread: Less than 25
- Smoke developed: Less than 50

OPERATING TEMPERATURE RANGE

- -20 deg F to 180 deg F - Continuous
- -20 deg F to 200 deg F - Intermittent

CONFIGURATIONS

- Diameters available: (R 6.0): 3"-10", 12", 14", 16", 18", 20" and 22"
- Diameters available: (R 8.0): 3"-10", 12", 14", 16", 18" and 20"
- Lengths available: 25 ft

APPROVALS

- ETL Listed/Approved to **UL 181** Standard
- NFPA standards **90A and 90B**
- HUD/FHA standards 515.2.1 Paragraph B
- Meets most federal, state and local codes and standards

Made in the USA

Job Name		Submitter:		Date:	
Location					Class 1 Insulated Flexible Air Duct Metalized Polyester vapor barrier/ AMGflex QFSD-010-01
Contractor					
Engineer					
Architect					



Mobile Home

The Quietflex Mobile Home Flex Duct has an extra heavy-duty, UV-Inhibited, polyethylene-vapor barrier and complies with HUD standards for outdoor use with mobile homes.

SERIES	R-VALUE	DIAMETER									
		6"	7"	8"	9"	10"	12"	14"	16"	18"	
51	4.2	•	•	•	•	•	•	•	•	•	
71	6.0	•	•	•	•	•	•	•	•	•	



Uninsulated Air Connector

SERIES	DIAMETER															
	3"	4"	5"	6"	7"	8"	9"	10"	12"	14"	15"	16"	17"	18"	19"	20"
06	•	•	•	•	•	•	•	•	•	•	•	•	•	•	•	•

Installation Notes:

- Not to be installed in lengths greater than 14'.
- Not to be used to vent appliances for cooling, heating, and clothes drying unless approved and recommended by appliance manufacturer.

Performance Data (Applies to all products)

- Rated Positive Pressure 10" W.C. per UL 181
- Rated Negative Pressure 1/2" W.C. per UL 181
- Velocity 6,000 FPM
- Temperature Range -20°F to 200°F (Intermittent) / -20°F to 180°F (Continuous)
- Flame Spread/Smoke Developed Less than 25/Less than 50

10-YEAR LIMITED PARTS WARRANTY. VISIT WWW.QUIETFLEX.COM FOR COMPLETE WARRANTY DETAILS.

LIMITED WARRANTY | LIMITATION OF LIABILITY | DISCLAIMER OF UNSTATED WARRANTIES

The flexible air duct is warranted by Quietflex Manufacturing Company, L.P., for ten (10) years against defects in material and workmanship. This warranty is for exchange of duct only and does not include installation.

WARRANTY EXCLUSIONS

Warranty is excluded if flexible air duct is used in the following installations / applications:

1. Where duct is exposed to direct or indirect light.
2. Where duct is used on the high - pressure side of variable air - volume (VAV) systems.

LIMITATION OF LIABILITY

Quietflex's liability for damages, whether in contract, in tort, under warranty, in negligence or otherwise, shall not exceed the return of the amount of the purchase price paid for the Quietflex products. Quietflex shall not be liable for special, indirect or consequential damages. Specification and performance data listed herein are subject to change without notice.

DISCLAIMER OF UNSTATED WARRANTIES

This warranty is the only warranty of Quietflex products. All other warranties, expressed or implied, including, but not limited to, warranties of merchantability and fitness for a particular purpose are expressly disclaimed. Quietflex is a registered trademark of Quietflex Manufacturing Company, L.P.



Quietflex Manufacturing Company, L.P.
4518 Brittmoore Road
Houston, Texas 77041
Phone 713.849.2163
Fax 713.849.0753
Toll Free 877.694.3669



QUALITY MANAGEMENT SYSTEM
CERTIFIED BY DNV
ISO 9001:2000
Houston Facility



SUBMITTAL RECORD _____
 JOB _____
 LOCATION _____
 SUBMITTED TO _____
 SUBMITTAL PREPARED BY _____
 APPROVED BY _____
 DATE _____



Submittal Form DN, UVDN Dyn-O-Ties

DESCRIPTION

Whenever your job calls for securing round flexible duct to outlets, pipes or fittings, you can do the job better, faster, and at a lower cost using DYN-O-TIES™, flexible duct ties. DYN-O-TIES, when properly installed, provide a secure connection of flexible duct listed by Underwriters Laboratories Inc., class 1.

Duro Dyne also offers two sizes of UV DYN-O-TIES that are made to resist Ultraviolet rays and adverse weather conditions when used in outdoor applications.

STORAGE

To ensure superior performance, nylon cable tie products should be stored in a sealed polyethylene bag at room temperature in at least 50% humidity (recommended 80% RH). Limit the exposure of unused cable ties to extreme heat and cold. Should cable ties be exposed to extreme temperatures and/or extreme relative humidity, store at room temperature and at least 50% humidity (recommended 80% RH) for at least 24 hrs in a sealed bag prior to further use.

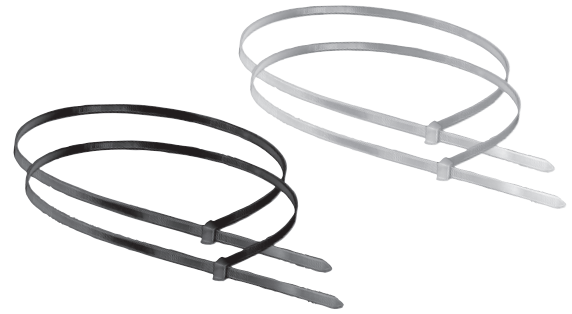

NYLON
6/6 V2 – available in five sizes
Self-extinguishing
Fungus inert
Normal service temp. range: – 40° F to 185° F
Test Results*: Nylon -175 lbs-

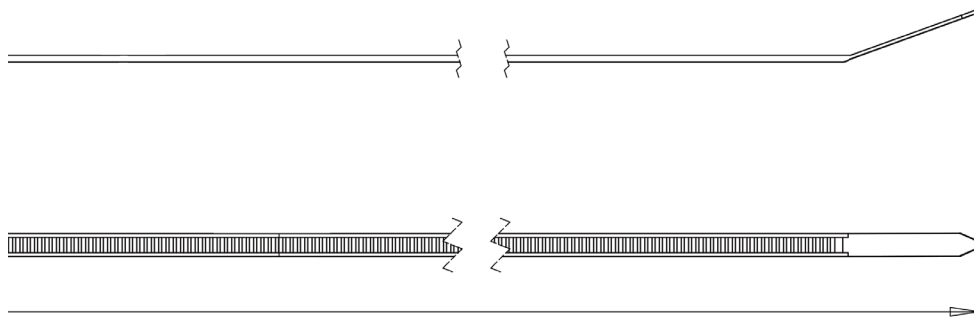

Non-Metallic
 Mechanical
 Fastener

181B-C 13ER
 MH19757

For use with UL nonmetallic
 airducts and air connectors

*Note: Ties are tested to CSA C22.2NO.18.5-02 / UL 1565. Test Method: Tie is secured at both ends forming a loop. A weight is suspended from the bottom of loop to determine tensile strength of DYN-O-TIE strap.

ITEM #	CODE	DESCRIPTION	COLOR	LENGTH	MAX. DIA.	PACKAGING	PKG./CTN
8251	DN24	Nylon - USA Made	Natural	24"	6"	25	20
8322	DN36	Nylon - USA Made	Natural	36"	11"	50	10
8312	DNC36	Nylon - USA Made	Natural	36"	11"	100	5
8323	DN48	Nylon - USA Made	Natural	48"	14"	50	10
8262	DNX60	Nylon - USA Made	Natural	60"	18"	50	10
7002	UVDN48	UV Resistant Nylon - Imported	Black	48"	14"	50	10
7003	UVDN36	UV Resistant Nylon - Imported	Black	36"	11"	50	10
8311	DN36	Nylon - USA Made	Natural	36"	11"	25	20
8305	DN48	Nylon - USA Made	Natural	48"	14"	25	20
7004	DN36N	Nylon - Imported	Natural	36"	11"	50	10
7005	DN48N	Nylon - Imported	Natural	48"	14"	50	10

Duro Dyne East Division, Bay Shore, NY 631-249-9000 Fax: 631-249-8346
 Duro Dyne Midwest Division, Fairfield, OH 513-870-6000 Fax: 513-870-6005
 Duro Dyne West Division, Fontana, CA 562-926-1774 Fax: 562-926-5778
 Duro Dyne Canada, Lachine, Quebec, Canada 514-422-9760 Fax: 514-636-0328
 www.durodyne.com E-mail: durodyne@durodyne.com



©2016 Duro Dyne Corporation
 Printed in USA 1/16
 BO008410

Dyn-O-Ties®

Whenever your job calls for securing round flexible duct to outlets, pipes or fittings, you can do the job better, faster, and at a lower cost using **DYN-O-TIES™**, flexible duct ties.

No tapes, no screws, no clamps. Position the flexible duct and slip a **DYN-O-TIE** around the flexible duct over the joint. Draw the **DYN-O-TIE** tight with our ratchet action hand tool. A push with the thumb completes the job by clipping off the excess nylon tab for the neatest and most secure connection you could want.

For those jobs requiring steel connections, Duro Dyne has designed a new stainless steel **DYN-O-TIE**. The same basic installation process applies when using the **DIT-1SS** installation tool.

DYN-O-TIES, when properly installed, provide secure, self-extinguishing joints when connecting certain types of flexible duct listed by Underwriters Laboratories Inc., class 1.

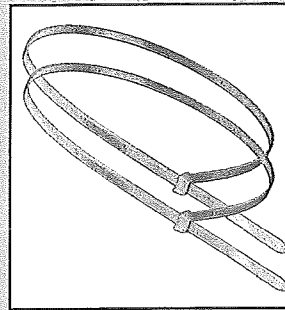

Nylon: Nylon 6/6 V2 – available in four sizes. Self-extinguishing. Fungus inert. Normal service temperature range: – 40° F to 185° F.

Test Results*: Nylon-275 lbs.

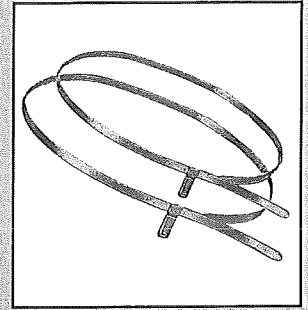

Stainless Steel: 430 stainless steel .020" x .3125 x 34" long.

Test Results*: Stainless Steel – 500 lbs.

***Test Method:** Tie is secured at both ends forming a loop. A weight is suspended from the bottom of loop to determine tensile strength of **DYN-O-TIE** strap.

Mini Dyn-O-Ties®

Made of molded natural color 6/6 nylon, these ties are perfect for bundling wires. The ties are designed to meet ASTM D638 for tensile strength and ASTM D789 for melting point. Not for use with DIT-2.

Item#	Model	Type	Length	Max. Dia.	Pkg.	Pkg./Ctn
8251	DN-22	Nylon	22	6"	25	20
8252	DNC-22	Nylon	22	6"	100	5
8253	DNF-22	Nylon	22	6"	500	1
8307	DN-33	Nylon	33	9"	25	20
8308	DNC-33	Nylon	33	9"	100	5
8309	DNF-33	Nylon	45	9"	500	1
8269	DT-34	Stainless	33	9"	25	20
8264	DN-45	Nylon	45	14"	25	20
8262	DNX-60	Nylon	60	18"	25	20

All materials shipped in master cartons of 500 pieces.

Item#	8378	8383
Model	DNC-8.5	DNC-14.5
Overall Length inches	8.5	14.5
Width inches	.130	.187
Bundle Diameter inches	1/16 - 2	1/16 - 3
Minimum Loop Tensile	40	50
Tensile Strength	11.2	11.2
Melting Point	491° F	491° F
UL Flammability	94V-2	94V-2

Packed 5 - 100 packs to a carton.

Dyn-O-Tie® Gun INSTALLATION TOOL

The DIT-2 gun is light weight and commonly used to install most makes of nylon duct ties.

The DIT-1SS gun with a specially designed nose piece is designed to install Duro Dyne type DT-34 stainless steel duct ties.

Item#	Model	Description
8229	DIT-2	For use w/nylon
8263	DIT-1SS	For use w/stainless

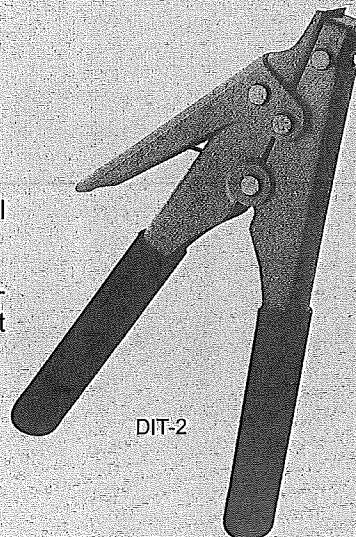

DIT-2

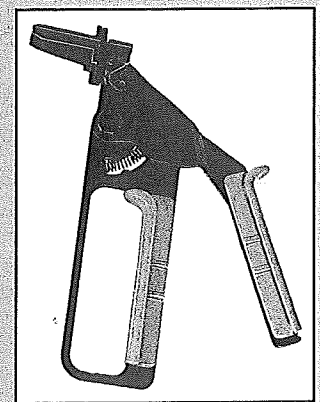

DIT-1SS

DP**1030****WATER BASED DUCT SEALANT****A fiber reinforced, water based, premium quality, UL Listed 181A-M / B-M, high velocity duct sealant for commercial and residential supply and return air duct use.****Recommended Uses:**

DP 1030 is recommended for sealing joints, seams, and duct wall penetrations on metal air duct.

DP 1030 is recommended for sealing connections on flexible duct or fiberglass duct board.

DP 1030 is recommended up to 15 inches water column pressure.

Features and Benefits:

- **LEED** Qualified
- UL Listed
- Excellent Workability
- Crack and Peel Resistant
- Mold and Mildew Resistant
- Excellent Dry Adhesion
- Indoor and Outdoor Usage
- Minimal Shrinkage
- Sag Resistant
- Excellent Water and U.V. Resistance
- Meets FDA, USDA, and EPA Standards
- Meets Requirements of NFPA 90A & 90B, ASTM E-84, and UL-723
- Paintable with latex or epoxy paints after cured

Directions For Use:**Uses:** DP 1030 may be used to seal joints on metal, flexible, and fiberglass duct board supply and return air duct.**Surface Preparation:** Surfaces should be clean, dry and free of dirt, oil and any foreign matter.**For sheet metal duct:** DP 1030 should be applied to all connections according to SMACNA standards. Brush, caulk, pump, or trowel DP 1030 on all duct seams. Apply to TDC/TDF and applied flange corners. Apply to all penetrations in the duct wall including sheet metal screw heads and tie rods. When caulking DP 1030, sealant should be brushed into seams.**For round and oval spiral duct:** Apply DP 1030 to the male section of the fitting or to the inside slip duct coupling. Secure with sheet metal screws per manufacturers requirements. Apply a 2-inch band of DP 1030 around outside of joint, covering all screws.**For rigid fiberglass air duct:** Assemble sections according to the manufacturers recommendations. Apply a 3-inch by 20 mil band of DP 1030 to the joint. Embed a fiberglass scrim (5 mil, 20 x 10 plain weave, 1.75 oz per sq. yd.) in the sealant and apply another 20 mil coat of DP 1030 over the scrim.**For flexible duct:** Install flexible duct per manufacturers instructions using drawbands or mechanical fastener. Apply DP 1030 at a rate of 80-90 sq. ft. per gallon (20-40 mils) between the end of the duct and the collar in a 2-inch band. Use DP 1030 to seal all connections of collar to metal duct or rigid fiberglass ductboard.**Pressure Testing:** Allow at least 48 hours before pressure testing. Since temperature and humidity conditions may vary, longer cure times may be required for specific installations.**Technical Data:****Color:** Gray or White**Base:** Water**Chemical Family:** Synthetic Latex**Solids Content:** 66 ± 2%**Viscosity:** Approx. 300,000 - 400,000 cps**Application Temperature:** 40°F - 110°F**Storage Temperature:** 40°F - 110°F**Freeze/Thaw Stability:** Do not allow to freeze**Service Temperature:** -25°F - 200°F**Flammability:** Non-flammable wet or dry**Flash Point:** No flash to boiling**Shelf Life:** 2 Years (unopened containers)**Cure Time:** 24-72 hours depending on temperature, humidity, and application**Coverage:** Dependent on application thickness, 80-90 sq. ft. at 20-40 wet mils**Clean Up:** Use warm water and soap**Packaging:** 1/12 gallon tubes, 1 gallon pails, 2 gallon pails, 5 gallon pails, 54 gallon drums**Pressure Classes:** Meets all SMACNA pressure classes**Seal Classes:** Meets all SMACNA seal classes**VOC:** <7 g/l

ASTM E-84 SURFACE BURNING CHARACTERISTICS

DP 1030 Duct Sealant applied to inorganic reinforced cement board

Flame Spread: 0 Smoke Developed: 0

Test applied in two 2" wide strips 8" on center (coverage 16% of the

exposed test sample area) at a spread rate of 250 sq. ft. per gal.

Flash point of finished sealant, closed cup. No flash to boiling.

UNDERWRITERS LABORATORIES INC.

LISTED ADHESIVES

16UK

UL 181 A-M

For use with UL Listed rigid fiberglass air ducts or connectors

UL 181 B-M

For use with UL Listed flexible air ducts or connectors

11609 Martens River Circle
Fountain Valley, CA 92708

Toll Free 800.641.0808

Phone 714.432.0600

Fax 714.432.0660

www.designpoly.com

DO NOT APPLY WHEN RAIN OR FREEZING TEMPERATURES WILL OCCUR WITHIN 36 HOURS. DO NOT THIN.

Revised 2-26-10



M&M Manufacturing Company

www.mmmfg.com

FORT WORTH (MkIV)
(817)-336-2311

FORT WORTH (Adolph)
(817)-334-0034

DALLAS
(972)-485-1504

HOUSTON
(713)-690-0585

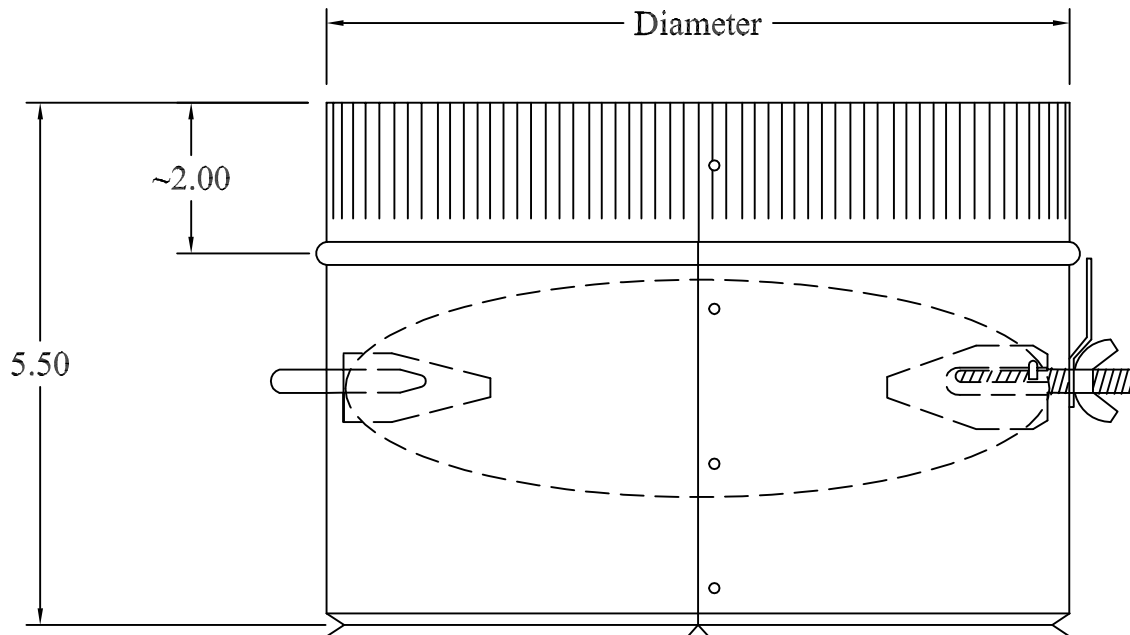
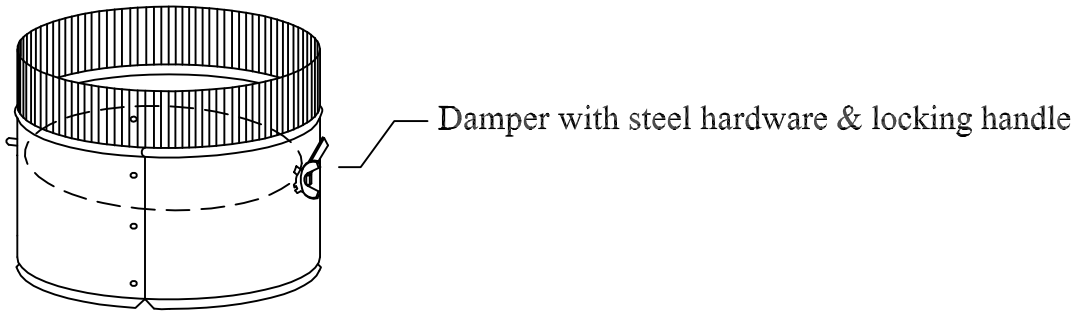

PART #: 504MSD(Size) **DESCRIPTION:** Metal Spin In Starting Collar

NOTES: Material: 4" - 14" = 28 ga.; 16" - 18" = 26 ga.; 20" = 24 ga.

ASTM-A653 CS B galvanized steel

4" W.C. Positive Pressure Commercial SMACNA Gauge

Order as #504MSD(diameter in inches)



100 Royal Way
 Temple, GA 30179
 Phone (800) 520-6593

SPECIFICATION DATA SHEET

Date: 7/1/2014

MODEL No. 101
Snaplock Furnace Pipe

DIMENSIONAL DATA

SIZES AVAILABLE: 3" THROUGH 24" DIAMETER

FABRICATION DATA

Material:

ASTM-A653 CS Type B Galvanized Steel,
 G-30 Coating LFQ Chemical Treatment
 *26GA G-90 Coating LFQ Chemical Treatment Available to meet SMACNA

<u>Diameter</u>	<u>Length Available</u>	<u>Gauges Available</u>
3"	2', 5'	30, 28, 26
4"	2', 4', 5'	30, 28, 26, 24
5"	2', 4', 5', 10'	30, 28, 26, 24
6"	2', 4', 5', 10'	30, 28, 26, 24
7"	2', 4', 5', 10'	30, 28, 26, 24
8"	2', 4', 5', 10'	30, 28, 26, 24
9"	2', 4', 5'	30, 28, 26, 24
10"	2', 4', 5'	30, 28, 26, 24
12"	2', 4', 5'	30, 28, 26, 24
14"	2', 3', 4', 5'	28, 26, 24
16"	2', 3', 4', 5'	28, 26, 24
18"	2', 3', 4', 5'	26, 24
20"	2', 3', 4', 5'	26, 24
22"	2', 3', 4', 5'	26, 24
24"	2', 3', 4'	24

FEATURES

Male and Female Locks are roll formed using a Modified Reeves Design. Pipe has 3/8" stiffener beads Rolled every 12" for added rigidity.
 2" Water Gauge +/-

OPTIONS

Aluminum: 4-14"-Fabricated from 3003-H14 in 26GA
 Stainless Steel: 4-14"-Fabricated from T304 2B in 26GA
 Both Stainless and Aluminum are sold in 4' pieces.
 24GA Matte Black available

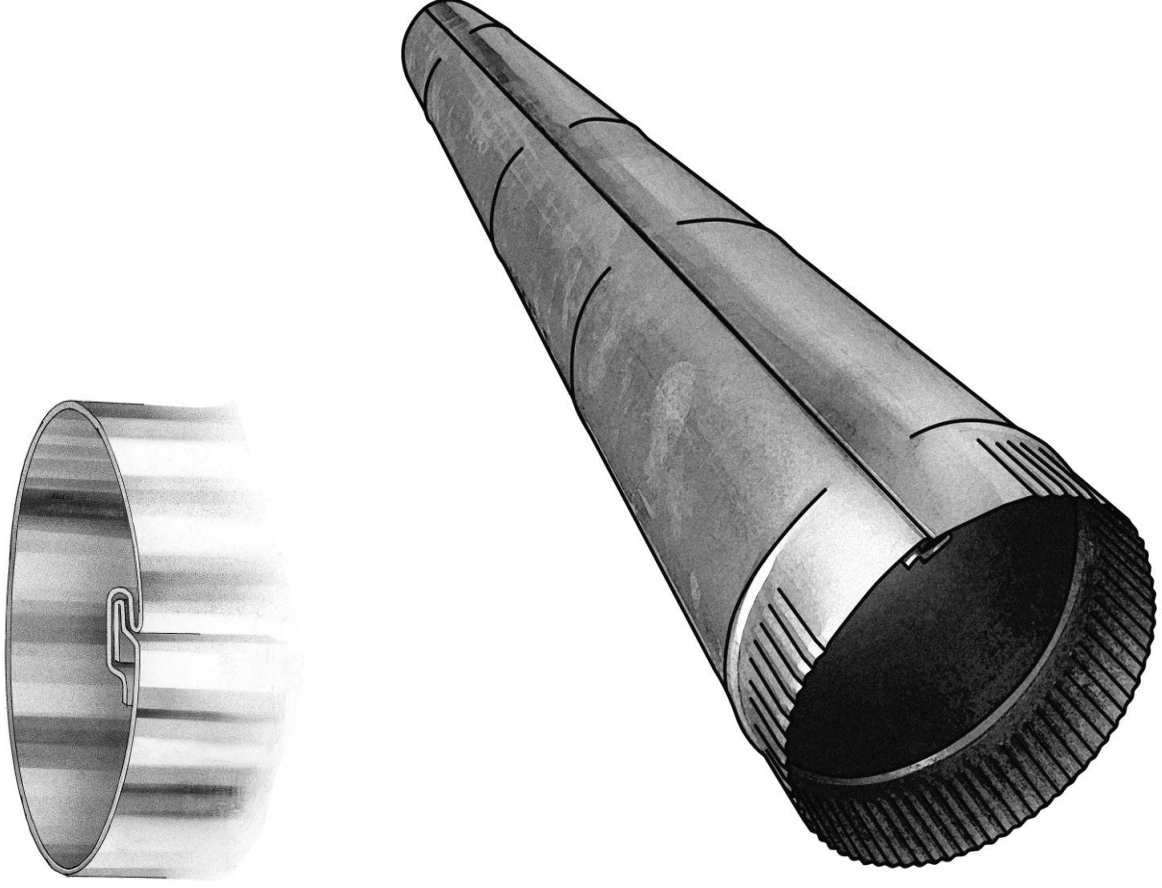

Superior Quality, Superior Service, Superior Value.. that's the Royal Advantage



M&M Manufacturing Company

www.mmmfg.com

FORT WORTH (Mark IV Pkwy)
(817)-336-2311

FORT WORTH (Adolph)
(817)-334-0034

DALLAS
(972)-485-1504

HOUSTON
(713)-690-0585

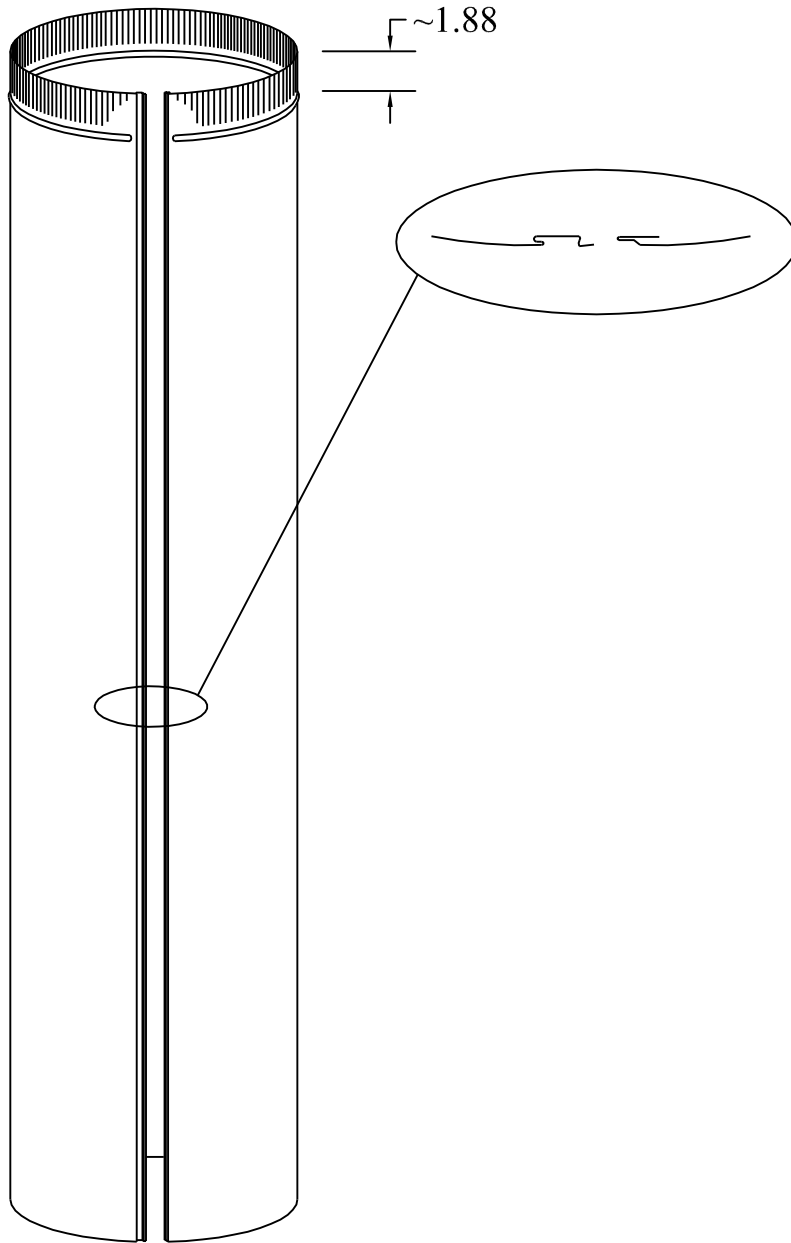

30 GAUGE MATERIAL		
SIZE	LENGTH	PART #
3"	24"	10001302403
3"	36"	10001303603
3'	60"	10001306003
4"	24"	10001302404
4"	36"	10001303604
4"	60"	10001306004
5"	36"	10001303605
5"	60"	10001306005
6"	36"	10001303606
6"	60"	10001306006
7"	36"	10001303607
7"	60"	10001306007
8"	36"	10001303608
8"	60"	10001306008
9"	36"	10001303609
9"	60"	10001306009
10"	36"	10001303610
10"	60"	10001306010
12"	36"	10001303612
12"	60"	10001306012

28 GAUGE MATERIAL		
SIZE	LENGTH	PART #
3"	48"	10001284803
4"	60"	10001286004
4"	48"	10001284804
5"	60"	10001286005
5"	48"	10001284805
6"	60"	10001286006
6"	48"	10001284806
7"	60"	10001286007
7"	48"	10001284807
8"	60"	10001286008
8"	48"	10001284808
9"	60"	10001286009
9"	48"	10001284809
10"	60"	10001286010
10"	48"	10001284810
12"	60"	10001286012
12"	48"	10001284812
14"	36"	10001283614
14"	48"	10001284814
14"	60"	10001286014
16"	36"	10001283616
18"	36"	10001283618

PART NUMBERS CONTINUE ON NEXT PAGE

DESCRIPTION: Round snaplock pipe

NOTES: ASTM-B209 Aluminum

ASTM-A653 CS B galvanized steel

Rating = $\frac{1}{2}$" water column



M&M Manufacturing Company

www.mmmfg.com

FORT WORTH (Mark IV Pkwy)
(817)-336-2311

FORT WORTH (Adolph)
(817)-334-0034

DALLAS
(972)-485-1504

HOUSTON
(713)-690-0585

26 GAUGE MATERIAL		
SIZE	LENGTH	PART #
16"	36"	10002263616
18"	36"	10002263618
20"	36"	10002263620
22"	36"	10002263622
24"	36"	10002263624
04"	48"	10002264804
05"	48"	10002264805
06"	48"	10002264806
08"	48"	10002264808
10"	48"	10002264810
12"	46"	10002264612
14"	48"	10002264814
04"	60"	10002266004
05"	60"	10002266005
06"	60"	10002266006
07"	60"	10002266007
08"	60"	10002266008
09"	60"	10002266009
10"	60"	10002266010
12"	60"	10002266012
14"	60"	10002266014
16"	60"	10002266016
18"	60"	10002266018
03"	36"	10005263603
04"	36"	10005263604
10"	36"	10005263610
05"	48"	10005264805
06"	48"	10005264806
07"	48"	10005264807
08"	48"	10005264808
09"	48"	10005264809
10"	48"	10005264810
12"	48"	10005264812
14"	48"	10005264814
16"	48"	10005264816
18"	48"	10005264818
04"	60"	10005266004
05"	60"	10005266005
06"	60"	10005266006
07"	60"	10005266007
08"	60"	10005266008
09"	60"	10005266009
10"	60"	10005266010
12"	60"	10005266012
03"	36"	10006263603
04"	36"	10006263604
10"	36"	10006263610
05"	48"	10006264805
06"	48"	10006264806
07"	48"	10006264807
08"	48"	10006264808
09"	48"	10006264809
10"	48"	10006264810
12"	48"	10006264812
14"	48"	10006264814
16"	48"	10006264816
18"	48"	10006264818
04"	60"	10006266004
05"	60"	10006266005
06"	60"	10006266006
07"	60"	10006266007
08"	60"	10006266008
09"	60"	10006266009
10"	60"	10006266010
12"	60"	10006266012
04"	48"	10004264804
06"	48"	10004264806
07"	48"	10004264807
08"	48"	10004264808
09"	48"	10004264809
10"	48"	10004264810
12"	48"	10004264812

24 GAUGE MATERIAL		
SIZE	LENGTH	PART #
16"	36"	10002243616
18"	36"	10002243618
20"	36"	10002243620
22"	36"	10002243622
24"	36"	10002243624
14"	48"	10002244814
05"	60"	10002246005
06"	60"	10002246006
07"	60"	10002246007
08"	60"	10002246008
09"	60"	10002246009
10"	60"	10002246010
12"	60"	10002246012
14"	60"	10002246014
16"	60"	10002246016
20"	60"	10002246020
22"	60"	10002246022
24"	60"	10002246024
05"	48"	10004244805
06"	48"	10004244806
07"	48"	10004244807
08"	48"	10004244808
09"	48"	10004244809
10"	46"	10004244610
12"	48"	10004244812
14"	48"	10004244814
16"	48"	10004244816
18"	48"	10004244818
20"	48"	10004244820
22"	48"	10004244822
24"	48"	10004244824
06"	60"	10004246006
07"	60"	10004246007
08"	60"	10004246008
09"	60"	10004246009
10"	60"	10004246010
12"	60"	10004246012
14"	60"	10004246014
07"	48"	10005244807
08"	48"	10005244808
12"	48"	10005244812
06"	60"	10005246006
08"	60"	10005246008
10"	60"	10005246010
12"	60"	10005246012
14"	60"	10005246014
07"	48"	10006244807
08"	48"	10006244808
12"	48"	10006244812
06"	60"	10006246006
08"	60"	10006246008
10"	60"	10006246010
12"	60"	10006246012
14"	60"	10006246014

0.025" ALUM MATERIAL		
SIZE	LENGTH	PART #
06"	48"	10007084806
04"	48"	10007084804
05"	48"	10007084805
06"	48"	10007084806
07"	48"	10007084807
08"	48"	10007084808
09"	48"	10007084809
10"	48"	10007084810
12"	48"	10007084812
14"	48"	10007084814
04"	60"	10007066004
05"	60"	10007066005
06"	60"	10007066006
07"	60"	10007066007
08"	60"	10007066008
09"	60"	10007066009
10"	60"	10007066010
12"	60"	10007066012
14"	60"	10007066014
09"	48"	10008084809
14"	48"	10008084814
12"	60"	10008086012

0.02" ALUM MATERIAL		
SIZE	LENGTH	PART #
03"	60"	10007076003
04"	60"	10007076004
05"	60"	10007076005
06"	60"	10007076006
07"	60"	10007076007
08"	60"	10007076008
09"	60"	10007076009
10"	48"	10007074810
10"	60"	10007076010

DESCRIPTION: Round snaplock pipe

NOTES: ASTM-B209 Aluminum
ASTM-A653 CS B galvanized steel
Rating = $\frac{1}{2}$" water column



M&M Manufacturing Company

www.mmmfg.com

FORT WORTH (MkIV)
(817)-336-2311

FORT WORTH (Adolph)
(817)-334-0034

DALLAS
(972)-485-1504

HOUSTON
(713)-690-0585

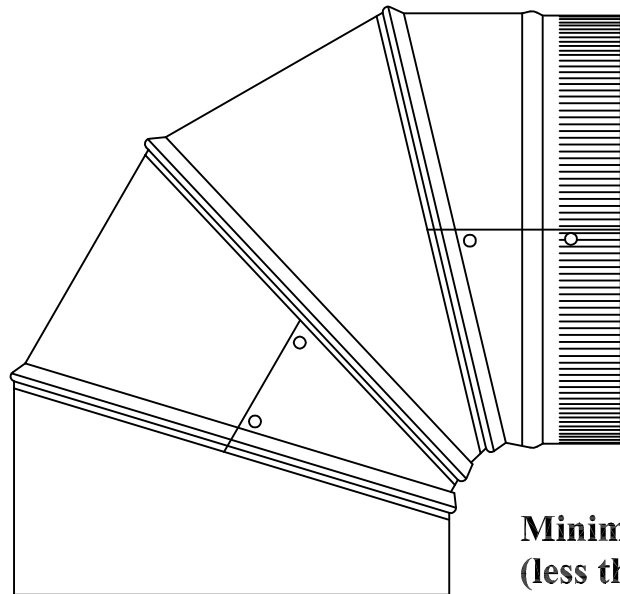
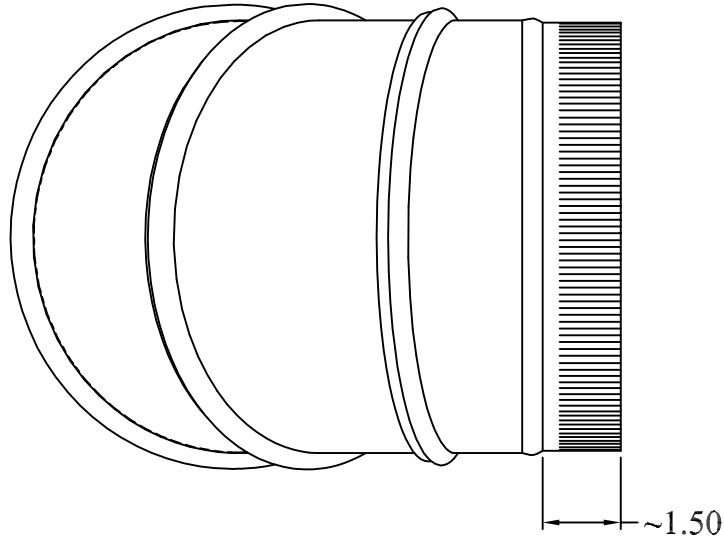

**Minimum radius
(less than 1x CL)**

PART #: 130(Size) **DESCRIPTION:** Round adjustable 90o elbow / 2" W.C. positive pressure

NOTES: Material: 3" - 10" = 28 ga.

ASTM-A653 CS B galvanized steel

Commercial SMACNA gauge

4 gore, adjustable from 90o to straight

Order as Pt# 130(Diameter in inches)

12" and larger standard elbows meet Commercial SMACNA requirements

Order 12" and larger as Pt# 125(Diameter in inches)



1000 South IH-35, Round Rock, TX 78681
Phone | 512-906-3963 • Fax | 512-837-3112 • www.aircomechanical.com

Sub-Section:

3) Hangers, Supports & Accessories

Spec Section Reference:

Airco Contact:

Phone:

Email:

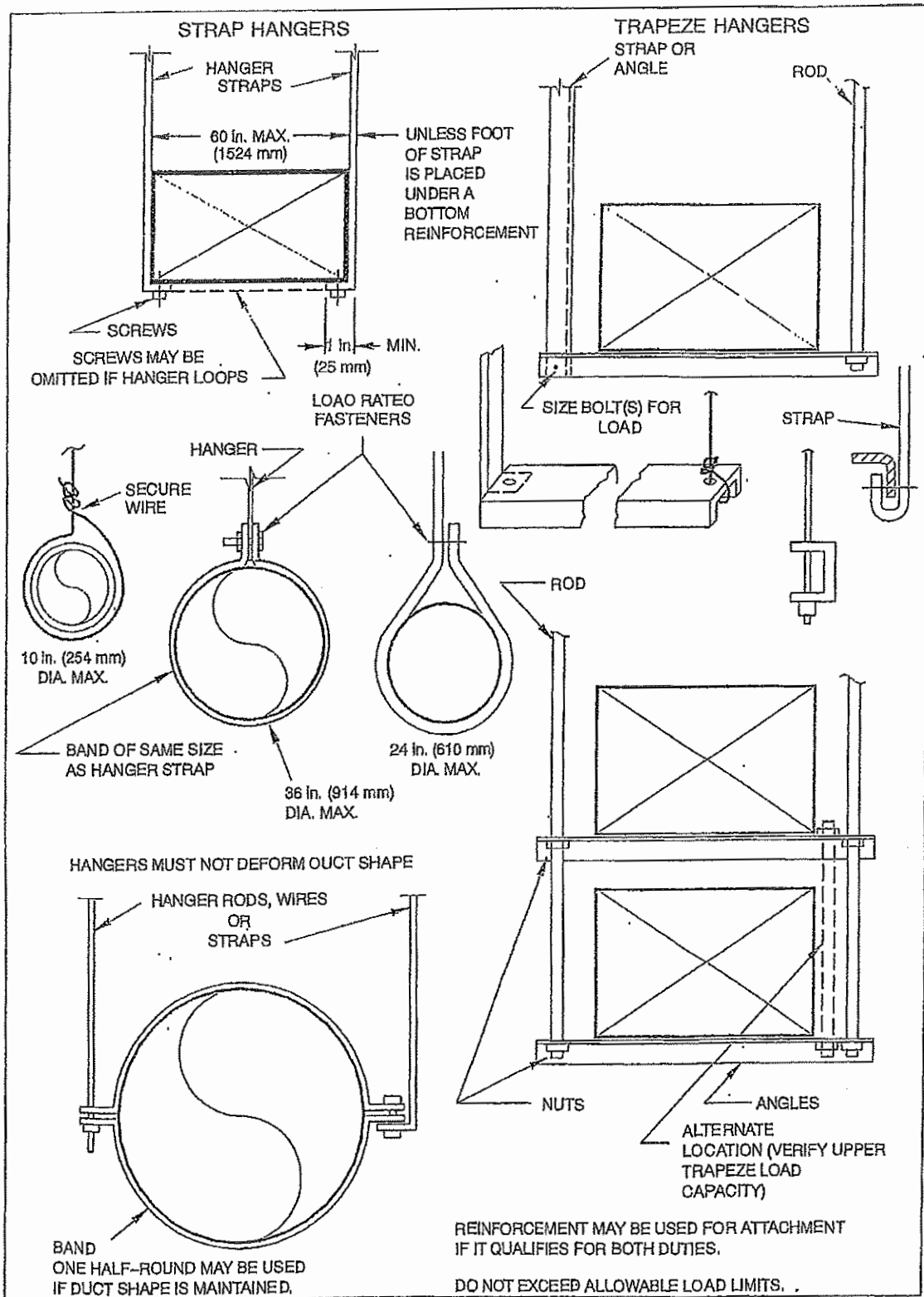

FIGURE 5-5 LOWER HANGER ATTACHMENTS

Maximum Half of Duct Perimeter	Pair at 10 ft Spacing		Pair at 8 ft Spacing		Pair at 5 ft Spacing		Pair at 4 ft Spacing	
	Strap	Wire/Rod	Strap	Wire/Rod	Strap	Wire/Rod	Strap	Wire/Rod
P/2 = 30"	1" x 22 ga	10 ga (.135")	1" x 22 ga	10 ga (.135")	1" x 22 ga	12 ga (.106")	1" x 22 ga	12 ga (.106")
P/2 = 72"	1" x 18 ga	3/8"	1" x 20 ga	1/4"	1" x 22 ga	1/4"	1" x 22 ga	1/4"
P/2 = 96"	1" x 16 ga	3/8"	1" x 18 ga	3/8"	1" x 20 ga	3/8"	1" x 22 ga	1/4"
P/2 = 120"	1 1/2" x 16 ga	1/2"	1" x 16 ga	3/8"	1" x 18 ga	3/8"	1" x 20 ga	1/4"
P/2 = 168"	1 1/2" x 16 ga	1/2"	1 1/2" x 16 ga	1/2"	1" x 16 ga	3/8"	1" x 18 ga	3/8"
P/2 = 192"	Not Given	1/2"	1 1/2" x 16 ga	1/2"	1" x 16 ga	3/8"	1" x 16 ga	3/8"
P/2 = 193" up	Special Analysis Required							
When Straps are Lap Joined Use These Minimum Fasteners:				Single Hanger Maximum Allowable Load				
				Strap			Wire or Rod (Dia.)	
1" x 18, 20, 22 ga -two #10 or one 1/4" bolt 1" x 16 ga -two 1/4" dia. 1 1/2" x 16 ga -two 3/8" dia. Place fasteners in series, not side by side.				1" x 22 ga - 260 lbs. 1" x 20 ga - 320 lbs. 1" x 18 ga - 420 lbs. 1" x 16 ga - 700 lbs. 1 1/2" x 16 ga - 1100 lbs.			0.106" - 80 lbs. 0.135" - 120 lbs. 0.162" - 160 lbs. 1/4" - 270 lbs. 3/8" - 680 lbs. 1/2" - 1250 lbs. 5/8" - 2000 lbs. 3/4" - 3000 lbs.	

Table 5-1 Rectangular Duct Hangers Minimum Size

NOTES:

- Dimensions other than gage are in inches.
- Tables allow for duct weight, 1 lb./sf insulation weight and normal reinforcement and trapeze weight, but no external loads!
- For custom design of hangers, designers may consult SMACNA's *Rectangular Industrial Duct Construction Standards*, the *AISI Cold Formed Steel Design Manual* and the *AISC Steel Construction Manual*.
- Straps are galvanized steel; other materials are uncoated steel.
- Allowable loads for P/2 assume that ducts are 16 ga maximum, except that when maximum duct dimension (w) is over 60 in. then P/2 maximum is 1.25 w.
- For upper attachments see Figs. 5-2, 5-3 and 5-4.
- For lower attachments see Fig. 5-5.
- For trapeze sizes see Table 5-3 and Fig. 5-6.
- 12, 10, or 8 ga wire is steel of black annealed, bright basic, or galvanized type.
- Cable hanging systems with adjustable mechanical device.



Dia.	Maximum Spacing	Wire Dia.	Rod	Strap
10 in. dn 250 mm dn	12 ft 3.7 m	One 12 ga One 2.75 mm	¼ in. 6.4 mm	1 in. × 22 ga 25.4 × 0.85 mm
11-18 in. 460 mm	12 ft 3.7 m	Two 12 ga or One 8 ga One 4.27 mm	¼ in. 6.4 mm	1 in. × 22 ga 25.4 × 0.85 mm
19-24 in. 610 mm	12 ft 3.7 m	Two 10 ga Two 3.51 mm	¼ in. 6.4 mm	1 in. × 22 ga 25.4 × 0.85 mm
25-36 in. 900 mm	12 ft 3.7 m	Two 8 ga Two 2.7 mm	⅜ in. 9.5 mm	1 in. × 20 ga 25.4 × 1.00 mm
37-50 in. 1270 mm	12 ft 3.7 m	—————→	Two ⅝ in. Two 9.5 mm	Two 1 in. × 20 ga (2) 25.4 × 1.00 mm
51-60 in. 1520 mm	12 ft 3.7 m	—————→	Two ⅝ in. Two 9.5 mm	Two 1 in. × 18 ga (2) 25.4 × 1.31 mm
61-84 in. 2130 mm	12 ft 3.7 m	—————→	Two ⅝ in. Two 9.5 mm	Two 1 in. × 16 ga (2) 25.4 × 1.61 mm
85-96 in. 2400 mm	12 ft 3.7 m	—————→	Two ½ in. Two 12 mm	Two 1½ in. × 16 ga (2) 38 × 1.61 mm

Table 5-2 Minimum Hanger Sizes for Round Duct

NOTES:

- Straps are galvanized steel; rods are uncoated or galvanized steel; wire is black annealed, bright basic or galvanized steel. All are alternatives.
- See Figure 5-5 for lower supports.
- See Figs. 5-2, 5-3 and 5-4 for upper attachments.
- Table allows for conventional wall thickness, and joint systems plus one lb./sf (4.89 Kg/m²) insulation weight. If heavier ducts are to be installed, adjust hanger sizes to be within their load limits; see allowable loads with Table 5-1. Hanger spacing may be adjusted by special analysis.
- Designers: For industrial grade supports, including saddles, single point trapeze loads, longer spans and flanged joint loads, see SMACNA's *Round Industrial Duct Construction Standards*.
- See Figs. 3-9 and 3-10 for flexible duct supports.

HANGER STANDARDS

0 - 30"	22 GA Strap	8' Spacing
30" - 72"	22 GA Strap	5' Spacing
72" - 120"	3/8" All Thread Rod & Unistrut	8' Spacing
121 - up	1/2" All Thread Rod & Unistrut	8' Spacing



Trapeze	Angles											Channels					
	A	B	C	D	E	F	G	H	I	J	K	L	M	N	O	P	
Length, in.	1" x 1" x 16 ga	1" x 1" x 16 ga	1-1/2" x 1-1/2" x 16 ga	1-1/2" x 1-1/2" x 16 ga	1-1/2" x 1-1/2" x 3/16"	1-1/2" x 1-1/2" x 1/4"	2" x 2" x 1/8"	2" x 2" x 3/16"	2" x 2" x 1/4"	2-1/2" x 2-1/2" x 3/16"	2-1/2" x 2-1/2" x 1/4"	3" x 3" x 1/4"	4" x 4" x 1/4"	3" x 4.1 lb/ft	3" x 6.0 lb/ft	4" x 5.4 lb/ft	
18	80	150	180	350	510	650	650	940	1230	1500	1960	-	-	-	-	-	
24	75	150	180	350	510	650	650	940	1230	1500	1960	-	-	-	-	-	
30	70	150	180	350	510	650	650	940	1230	1500	1960	-	-	-	-	-	
36	60	150	160	340	500	620	620	920	1200	1480	1940	-	-	-	-	-	
42	40	110	140	320	480	610	610	900	1190	1470	1930	-	-	-	-	-	
48	-	80	110	290	450	580	580	870	1160	1440	1900	-	-	-	-	-	
54	-	-	-	250	400	540	540	840	1120	1400	1860	-	-	-	-	-	
60	-	-	-	190	350	490	490	780	1060	1340	1800	-	-	-	-	-	
66	-	-	-	100	270	400	400	700	980	1260	1720	-	-	-	-	-	
72	-	-	-	-	190	320	320	620	900	1180	1640	-	-	-	-	-	
78	-	-	-	-	-	210	210	500	790	1070	1530	-	-	-	-	-	
84	-	-	-	-	-	-	-	380	660	940	1400	2310	4680	4650	5980	9080	
96	-	-	-	-	-	-	-	-	320	600	1060	1970	4340	3870	4950	8740	
108	-	-	-	-	-	-	-	-	-	-	-	2510	7240	5760	7780	15650	
120	-	-	-	-	-	-	-	-	-	-	-	1220	5950	4120	5930	13200	
132	-	-	-	-	-	-	-	-	-	-	-	-	4350	2540	3920	10820	
144	-	-	-	-	-	-	-	-	-	-	-	-	2420	-	2000	8330	
Section Properties	I _x	0.012	0.022	0.041	0.078	0.110	0.139	0.190	0.348	0.547	0.703	1.240	3.040	1.660	2.070	3.850	
	Z	0.016	0.031	0.037	0.072	0.104	0.13	0.190	0.247	0.303	0.394	0.577	1.050	1.100	1.380	1.930	
	A	0.120	0.234	0.180	0.359	0.527	0.688	0.484	0.715	0.938	0.902	1.190	1.440	1.940	1.210	1.760	1.590
	lb/ft	0.440	0.800	0.660	1.230	1.800	2.340	1.650	2.440	3.190	3.070	4.100	4.900	6.600	4.100	6.000	5.400

Table 5-3 Allowable Loads in Pounds for Trapeze Bars

NOTES:

- It is assumed that steel with a yield strength of 30,000 psi or greater is used.
- Loads above assume that a hanger rod is 6 in. max distance from the duct side for lengths of 96 in. or less, and 3 in. for greater lengths.
- Framing Struts, see Table 5-4 and other steel shapes having equal or greater (I_x and Z) properties may be used in place of listed shapes. I_x is in in.⁴, Z is in in.³, and A is in in.².
- See Fig. 5-6 for load calculation method and Table 5-1 for rod and strap load limits.

FRAMING CHANNEL (STRUT) MAY BE USED AS AN ALTERNATIVE TO THE TRAPEZE ANGLES SHOWN IN TABLE 5-3 AS FOLLOWS:

Channel (Strut)			Section Modulus (Z)	Moment of Inertia (I)	Trapeze
H	W	GA	in. ³	in. ⁴	Table 5-3
1 in.	1 5/8 in.	12	0.0923	0.0533	A, B, C
1 3/8 in.	1 5/8 in.	12	0.1559	0.1209	D, E
1 5/8 in.	1 5/8 in.	12	0.2042	0.1850	F, G
2 7/16 in.	1 5/8 in.	12	0.3927	0.5203	H, I
3 1/4 in.	1 5/8 in.	12	0.5772	0.9379	J, K

Channel (Strut)			Section Modulus (Z)	Moment of Inertia (I)	Trapeze
H (mm)	W (mm)	MM	mm ³	mm ⁴	Table 5-3M
25.4	41.3	2.45	1500	22,200	A, B, C
34.9	41.3	2.45	2600	50,300	D, E
41.3	41.3	2.45	3300	77,000	F, G
61.9	41.3	2.45	6400	216,000	H, I
82.6	41.3	2.45	10,300	454,000	J, K

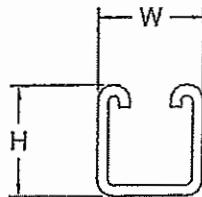

Table 5-4 Channel (Strut) Used as Trapeze

SAMMY X-PRESS® Installs into Metal Deck, Purlin, or Tubular Steel

SAMMY X-PRESS® - Vertical Application



Application

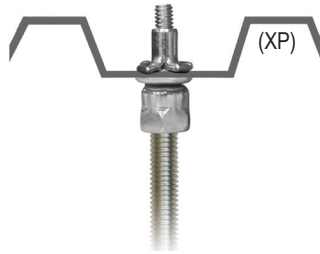

Product Features

- The **Sammy X-Press** expands to provide direct vertical attachment in:
 - light gauge steel deck or purlin (22 ga. - 1/8").
- Installs in seconds with Sammy X-Press It® Tool, saving time & installation costs.
- Use in applications where access to the back of the installed fastener is prohibited, i.e. metal roof deck, tubular steel, or vapor barrier fabric.
- Less jobsite material needed.
- No retaining nut required.
- Provides design flexibility.
- Made in the U.S.A.



Approvals	Rod Size	Part Number	Model	Description	Ultimate Pullout (lbs)	UL Test Load (lbs)	UL Min Thick	FM Test Load (lbs)	FM Min Thick	Max Thick	Box Qty	Case Qty	Application
VERTICAL MOUNT													
UL	1/4"	8181922	XP 200	Sammy X-Press 200	1146 (22 ga)	185 (Luminaire) 250 (Luminaire)	.027" .056"			.125"	25	125	Metal Deck
UL FM	3/8"	8150922	XP 20	Sammy X-Press 20	1146 (22 ga)	850 (2 1/2" Pipe) 185 (Luminaire) 250 (Luminaire) 283 (Conduit & Cable)	.027" .027" .056" .029"	940 (2" Pipe) 1475 (4" Pipe)	.029" .104"	.125"	25	125	Metal Deck
UL FM	3/8"	8153922	XP 35	Sammy X-Press 35	1783 (16 ga)	1500 (4" Pipe) 185 (Luminaire) 250 (Luminaire) 416 (Conduit & Cable)	.060" .029" .056" .059"	940 (2" Pipe) 1475 (4" Pipe)	.029" .104"	.125"	25	125	Purlin
UL	3/8"	8150922	XP 20	Sammy X-Press 20	1146 (22 ga)	850 (2 1/2" Pipe)		Pre-Pour Structural Concrete @ 3000 psi			25	125	Metal Deck (Pre-Pour) Metal Deck (Post-Pour)
								Post-Pour Range II LWC ≤ 35 PCF (lbs/ft³)					

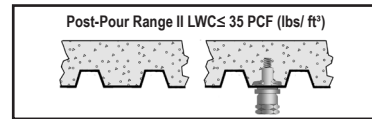
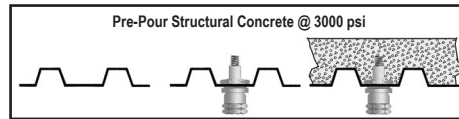
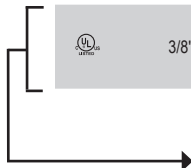

SIDEWINDER X-PRESS™ - Horizontal Application



Application



Product Features

- The **Sidewinder X-Press** expands to provide horizontal attachment in:
 - 16 ga - 3/16" steel - purlin, tubular steel.
- Installs in seconds with Sammy X-Press It® Tool, saving time & installation costs.
- Use in applications where access to the back of the installed fastener is prohibited; i.e. metal roof deck, tubular steel, or vapor barrier fabric.
- Less jobsite material needed.
- No retaining nut required.
- Provides design flexibility.
- Made in the U.S.A.



Approvals	Rod Size	Part Number	Model	Description	Ultimate Pullout (lbs)	UL Test Load (lbs)	UL Min Thick	FM Test Load (lbs)	Max Thick	Box Qty	Case Qty	Application	
HORIZONTAL MOUNT													
UL	3/8"	8293957	SWXP 35	Sidewinder X-Press 35	1798 (16 ga)	1250 (3 1/2" Pipe) 80 (Luminaire) 416 (Conduit & Cable)	.059"			.125"	25	125	Purlin



SAMMYS® FOR STEEL

SAMMYS® FOR STEEL - Vertical Application



Application

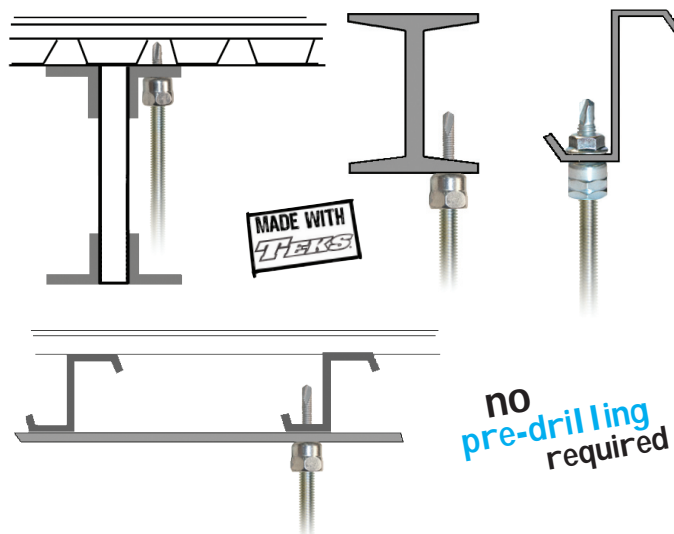

Product Features

- Made with Teks® self-drilling fasteners - no pre-drilling required.
- Installs into steel range from 20 gauge - 1/2" thicknesses.
- Saves time from traditional methods.
- Reduces installation costs.
- Quick to install using the Sammys Nut Driver with an 18V cordless drill/driver.
- A standard screwgun with a depth sensitive nosepiece should be used to install Teks. For optimal fastener performance, the screwgun should be a minimum of 6 amps and have an RPM range of 0-2500.
- Made in the U.S.A.

Watch a video demonstration at www.itwbuildex.com



#14 Black Nut Driver Part # 8113910



#14 SW Red Nut Driver Part # 8114910

Approvals	Rod Size	Part Number	Model	Screw Descriptions	Ultimate Pullout (lbs)	UL Test Load (lbs)	FM Test Load (lbs)	Min Thick	Max Thick	Box Qty	Case Qty
VERTICAL MOUNT											
	1/4"	8024957	DSTR 100 *	1/4-20 x 1" TEKS 3	1510 (20 ga.)			.036"-20 ga	3/16"	25	125
	1/4"	8025957	DST 100	1/4-14 x 1" TEKS 3	446 (20 ga.)			.036"-20 ga	3/16"	25	125
	1/4"	8026957	DST 150	1/4-14 x 1-1/2" TEKS 3	970 (16 ga.)			.036"-20 ga	3/16"	25	125
	1/4"	8027957	DST 200	1/4-14 x 2" TEKS 3	446 (20 ga.)			.036"-20 ga	3/16"	25	125
	1/4"	8030957	TEK 500	12-24 x 1-1/2" TEKS 5	3125 (3/16")			.188"-3/16"	1/2"	25	125
	3/8"	8038957	DSTR 1 *	1/4-20 x 1" TEKS 3	1510 (20 ga.)	1500	1475	.036"-20 ga	3/16"	25	125
	3/8"	8037957	DSTR 1-1/2 *	12-24 x 1-1/2" TEKS 5	1510 (3/16")	1500	1475	.060"-16 ga.	1/2"	25	125
	3/8"	8039957	DSTR 516 *	5/16-18 x 1-1/4" TEKS 3	2200 (20 ga.)	1500	1475	.036"-20 ga	3/16"	25	125
	3/8"	8040957	DST 10	1/4-14 x 1" TEKS 3	446 (20 ga.) 970 (16 ga.)			.036"-20 ga	3/16"	25	125
	3/8"	8077925	DST 10-SS	1/4-14 x 1" TEKS 3	446 (20 ga.) 970 (16 ga.)			.036"-20 ga	3/16"	25	125
	3/8"	8041957	DST 15	1/4-14 x 1-1/2" TEKS 3	446 (20 ga.) 970 (16 ga.)			.036"-20 ga	3/16"	25	125
	3/8"	8078925	DST 15-SS	1/4-14 x 1-1/2" TEKS 3	446 (20 ga.) 970 (16 ga.)			.036"-20 ga	3/16"	25	125
	3/8"	8042957	DST 20	1/4-14 x 2" TEKS 3	446 (20 ga.) 970 (16 ga.)			.036"-20 ga	3/16"	25	125
	3/8"	8043957	DST 25	1/4-14 x 2-1/2" TEKS 3	446 (20 ga.) 970 (16 ga.)			.036"-20 ga	3/16"	25	125
	3/8"	8044957	DST 30	1/4-14 x 3" TEKS 3	446 (20 ga.) 970 (16 ga.)			.036"-20 ga	3/16"	25	125
	3/8"	8045957	DST 516	5/16-18 x 1-1/4" TEKS 3	1500 (3/16")	1500	1475	.125"-1/8"	3/16"	25	125
	3/8"	8046957	TEK 50	12-24 x 1-1/2" TEKS 5	3125 (3/16")	1500	1475	.250"-1/4"	1/2"	25	125
	1/2"	8031925	DST 2.0	1/4-14 x 2" TEKS 3	446 (20 ga.) 970 (16 ga.)			.188"-3/16"	1/4"	25	125
	1/2"	8033925	DSTR 1.0 *	1/4-20 x 1" TEKS 3	1510 (20 ga.)			.036"-20 ga	3/16"	25	125
	1/2"	8034925	DSTR 5.16 *	5/16-18 x 1-1/4" TEKS 3	2220 (20 ga.)			.036"-20 ga	3/16"	25	125
	1/2"	8035925	DST 5.16	5/16-18 x 1-1/4" TEKS 3	1500 (3/16")			.125"-1/8"	3/16"	25	125
	1/2"	8036925	TEK 5.0	12-24 x 1-1/2" TEKS 5	3125 (3/16")			.188"-3/16"	1/2"	25	125

*Includes retaining nut



SPECIAL NUT DRIVER SYSTEM: The nut drivers were designed with a unique spin-off feature which provides a fast and safe installation each time. When the face of the driver comes into contact with the material you are installing into, continue drilling until nut driver spins free. Installation is then complete. Warranty requires the use of the appropriate nut driver for installations.

Model #300 Domestic Beam Clamp

Model #300 I Import Beam Clamp Universal/Reversible (Double Rod Hole)

SIZE RANGE: #300 -- 3/8" thru 7/8" rod sizes
#300I -- 3/8" rod size only

MATERIAL: Malleable iron casting with a hardened cup point set screw and locknut

ALTERNATE MATERIAL OR FINISH: EG, HDG

APPROVED BY: Factory Mutual

LISTED BY: Underwriters Laboratories Inc. to U. S. and Canadian safety standards

CONFORMS WITH: Federal Specification WW-H-171 (Type 23), Manufacturers Standardization Society ANSI/MSS-SP-58 (Type 19 & 23); install in accordance with ANSI/MSS-SP-69.

SERVICE: Structural attachment (with *infinite adjustment*) to *top* or *bottom* of metal beams, purlins, channel or angle iron to support hanger rod.

ORDERING: Specify size, model number and name

NOTE: Set screw must be tightened onto the sloped side of the I-Beam, channel or angle iron flange and torqued to 60 inch pounds.

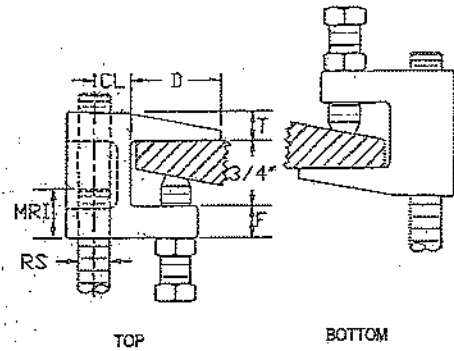

May be mounted in either position



RS	Max. pipe size	CL	D	MRI	F	T	Max. recom. load lbs.	
							Top	Bottom
3/8"	4"	7/16"	1-1/8"	1/2"	3/8"	3/8"	500	250
1/2"	8"	9/16"	1-1/16"	11/16"	1/2"	1/2"	950	760
5/8"	8"	9/16"	1-1/16"	11/16"	1/2"	1/2"	950	760
3/4"	8"	9/16"	1-1/8"	13/16"	5/8"	3/8"	950	760
7/8"	8"	9/16"	1-1/8"	13/16"	5/8"	3/8"	950	760

For corresponding Retainer strap see page 36

Model # 200C Retainer Strap

SIZE RANGE: 3/8" thru 7/8" rod sizes (RS); 4-1/2", 6", 8", 10" and 14" lengths (L)

MATERIAL: Pre-galvanized carbon steel

ALTERNATE MATERIAL OR FINISH: HDG

SERVICE: To be utilized when a retainer strap is specified with Model #200 C Clamp.

ORDERING: Specify rod size, length (L) (order 2" longer than beam flange width), model number and name.

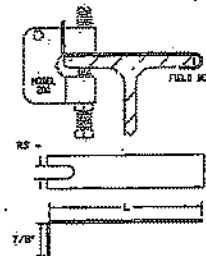

Fig. 292: Right-Hand Thread
Fig. 292L: Left-Hand Thread

Universal Forged Steel (UFS) Beam Clamp With Weldless Eye Nut

Material: Forged steel

Finish: Plain or Galvanized

Service: For suspension of heavy loads from beams with flange widths to 15' and flange thickness to 1.031.

Approvals: Complies with Federal Specification A-A-1192A (Type 28 without links; Type 29 with links) WW-H-171-E (Type 28 without links; Type 29 with links) and MSS-SP-69 (Type 28 without links; Type 29 with links).

Installation: Fit jaws over edges of lower beam flange and tighten nuts on tie rod to lock clamp in place.

Features:

- Weldless eye nut provides for horizontal pipe movement without binding.
- Weldless eye nut is furnished tapped to any specified rod size up to the maximum rod size.
- Tie rod assures a tight non-slip fit to the beam.

Ordering: Specify clamp size, figure number, name, rod size and finish.

Note: The application of a load to a structural beam by means of a beam clamp produces a transverse stress, perpendicular to the axis of the beam, in the flange to which the load is applied.

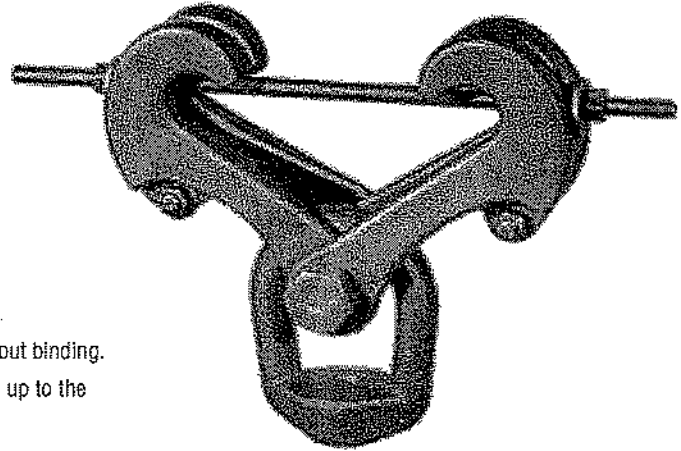
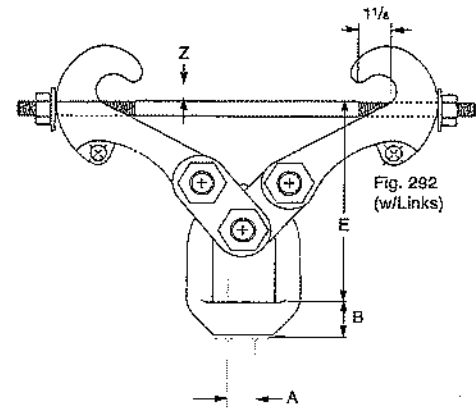

Fig. 292, Fig. 292L: Loads (lbs) • Weight (lbs) • Dimensions (in)

Clamp Size No.	Max Rod Size A	Max Load ■	Weight	Z Max †	B	Jaw and Eye Nut Size ▲
1	3/4	3,230	3.9	0.60	1 1/4	292 - 1 / 1
2	1		9.2		1 1/16	292 - 2 / 2
3 •			13.0		1 1/2	292 - 3 / 2
4			21.7			
5 •		33.9	1.031	2 1/8	292 - 3 / 3	
6	11,500	28.9		4 9/16	292 - 3 / 4	
7 •		35.8				
8		2		36.8		

▲ For reference only, order by clamp size.
 • Furnished with links.
 ■ Note: Load capacity based on rod sizes shown. For load capacity of other rod sizes see page PH-207
 † For actual "Z" dimensions see table on page PH-209



Clamp Size No.	Width of Beam Flange (in)												
	Rod Take Out - E (in)												
	3	4	5	6	7	8	9	10	11	12	13	14	15
1	4 1/2	4 5/16	4 1/16	3 5/8	2 7/8	-	-	-	-	-	-	-	-
2	-	4 3/4	4 7/16	4 1/16	3 3/8	-	-	-	-	-	-	-	-
3 •	-	-	-	-	5 15/16	6	5 5/16	5	-	-	-	-	-
4	-	6 13/16	6 5/8	6 3/8	5 7/8	5 7/8	5 3/8	4 13/16	-	-	-	-	-
5 •	-	-	-	-	-	-	-	-	8 1/8	7 3/4	7 1/8	6 5/8	6 1/16
6	-	7 3/16	7	6 3/4	6 1/4	6 5/16	5 13/16	5 3/16	-	-	-	-	-
7 •	-	-	-	-	-	-	-	-	8 1/2	8 1/8	7 1/2	7	6 7/16
8	-	8 5/8	8 1/16	8 3/16	7 3/4	7 3/4	7 1/4	6 5/8	-	-	-	-	-

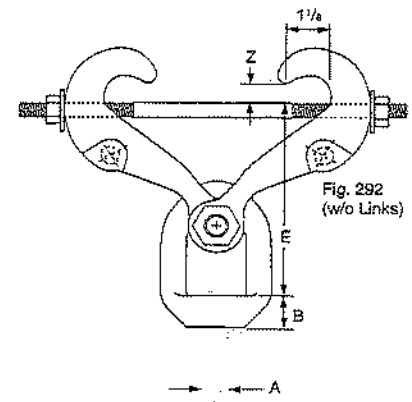

Beam Clamps

Hardware

ATR

All Threaded Rod

- Available in 36" (91.4 cm), 72" (182.9 cm), 120" (304.8 cm), 144" (365.7 cm) lengths
- Safety Factor of 5 on recommended load
- Standard finish: Zinc-Plated, Stainless Steel Type 304

Part No. & Size	Threads Per Inch	Recommended Load		Wt./C Ft. (3048.0 cm)	
		Lbs.	kN	Lbs.	kg
ATR 1/4"	20	240	(1.07)	12	(5.44)
ATR 5/16"	18	400	(1.78)	19	(8.62)
ATR 3/8"	16	730	(3.24)	29	(13.15)
ATR 1/2"	13	1350	(6.00)	53	(24.04)
ATR 5/8"	11	2160	(9.60)	89	(40.37)
ATR 3/4"	10	3230	(14.37)	123	(55.79)
ATR 7/8"	9	4480	(19.93)	170	(77.11)
ATR 1"	8	5900	(26.24)	225	(102.06)

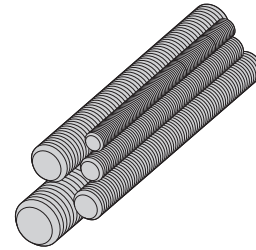

B655 Rod Coupling B656 Reducer Rod Coupling

- Load rating for each coupler meets All Threaded Rod value
- Standard finish: Zinc-Plated, Stainless Steel Type 304

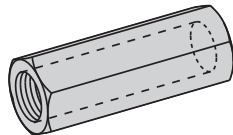

Part No.	Size	Recommended Load		Length		Wt./C	
		Lbs.	kN	In.	mm	Lbs.	kg
B655-1/4	1/4"-20	240	(1.07)	7/8"	(22.2)	1.9	(.86)
B655-5/16	5/16"-18	380	(1.69)	7/8"	(22.2)	1.8	(.81)
B655-3/8	3/8"-16	730	(3.24)	1 1/8"	(28.6)	3.6	(1.63)
B655-1/2	1/2"-13	1350	(6.00)	1 3/4"	(44.4)	11.3	(5.12)
B655-5/8	5/8"-11	1810	(8.05)	2 1/8"	(54.0)	17.6	(7.98)
B655-3/4	3/4"-10	2710	(12.05)	2 1/4"	(57.1)	28.1	(12.74)
B655-7/8	7/8"-9	3770	(16.77)	2 1/2"	(63.5)	57.2	(25.94)
B655-1	1"-8	4960	(22.06)	2 3/4"	(69.8)	73.7	(33.43)

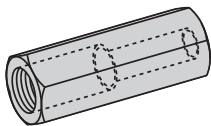

Part No.	Size	Recommended Load		Length		Wt./C	
		Lbs.	kN	In.	mm	Lbs.	kg
B656-3/8 x 1/4	3/8"-16 & 1/4"-20	240	(1.07)	1"	(25.4)	3.7	(1.68)
B656-1/2 x 3/8	1/2"-13 & 3/8"-16	730	(3.24)	1 1/4"	(31.7)	6.6	(2.99)
B656-5/8 x 1/2	5/8"-11 & 1/2"-13	1350	(6.00)	1 1/4"	(31.7)	11.6	(5.26)
B656-3/4 x 5/8	3/4"-10 & 5/8"-11	1810	(8.05)	1 1/2"	(38.1)	20.6	(9.34)
B656-7/8 x 3/4	7/8"-9 & 3/4"-10	2710	(12.05)	1 3/4"	(44.4)	39.4	(17.87)

BHR Series Hot Rods for Trapeze Hangers

- 12" length of threaded rod completely assembled with rod coupling, locking hex nuts, square washer, and channel nut.
- Standard finish: Zinc-Plated

Part No.	Rod Size	Recommended Load		Wt./C	
		Lbs.	kN	Lbs.	kg
BHR1225ZN	1/4"-20	240	(1.07)	41	(18.6)
BHR1238ZN	3/8"-16	730	(3.24)	63	(28.6)
BHR1250ZN	1/2"-13	1350	(6.00)	98	(44.4)
BHR1262ZN	5/8"-11	1500	(6.67)	148	(67.1)

Note: Based on use with 12 ga. channel.

(BHR1225, BHR1238, and BHR1250 use combo nut washers instead of square washers and channel nuts)



SC228 Hanger Rod Stiffener

- For $\frac{3}{8}$ " thru $\frac{5}{8}$ " ATR
- Strut ordered separately
- Standard finish: ZN
- Wt./C 21 Lbs. (9.5 kg)

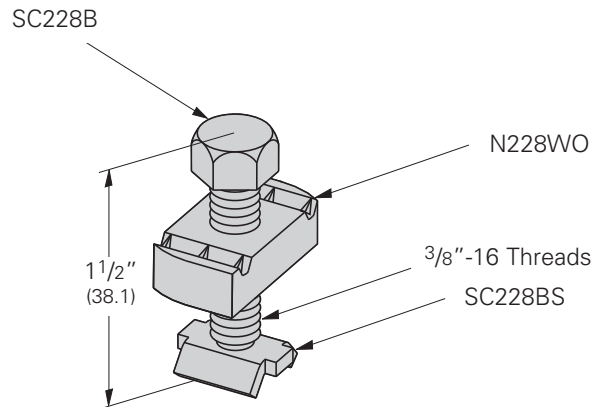
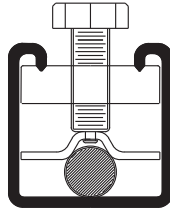

Fig. 98 Rod Stiffener

- For $\frac{3}{8}$ " thru $\frac{7}{8}$ " ATR
- Use with 12 ga. strut only, ordered separately
- Secures channel to hanger rod for vertical seismic bracing
- Standard finish: ZN
- Wt./C 11 Lbs. (5.0 kg)

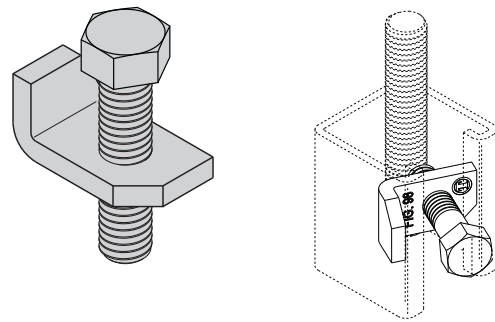
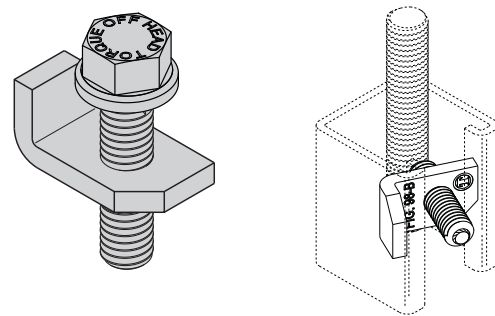

Fig. 98B Rod Stiffener with Break-Off Bolt Head

- For $\frac{3}{8}$ " thru $\frac{7}{8}$ " ATR
- Use with 12 ga. strut only, ordered separately
- Secures channel to hanger rod for vertical seismic bracing
- Uses a snap-off bolt head
- Standard finish: ZN
- Wt./C 13 Lbs. (5.9 kg)



SC-UB Hanger Rod Stiffener

- For $\frac{3}{4}$ " thru $\frac{7}{8}$ " ATR
- Strut ordered separately
- Includes: (1) B3188-1 $\frac{1}{2}$ WO U-Bolt
(2) $\frac{3}{8}$ "-16 Hex Nuts
(1) 2-Hole Plate
- Standard finish: ZN
- Wt./C 50 Lbs. (22.7 kg)

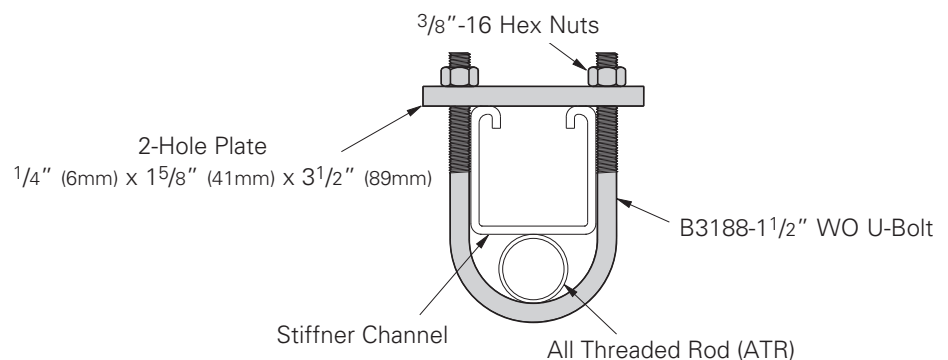

Reference page 45 for general fitting and standard finish specifications.

CHANNEL

H-132

1 5/8" X 1 5/8"
12 Gauge Channel
wt./100 ft. - 194#

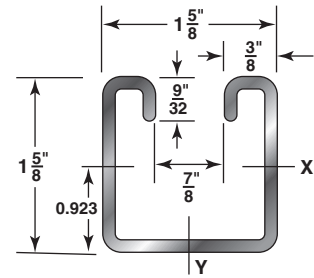
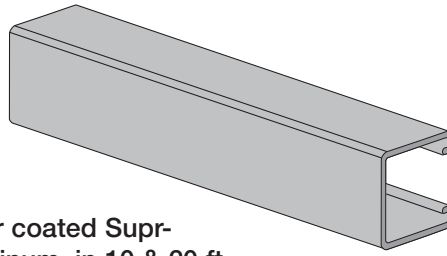

Stocked in pre-galvanized, plain, powder coated Supr-Green, zinc trivalent, PVC coated & aluminum, in 10 & 20 ft. lengths. Note: Also available in Stainless Steel 304 & 316 Alloys. Other materials, finishes & lengths are available upon request.

SECTION PROPERTIES

Catalog No.	Wt./Ft. Lbs.	Area of Section Sq. In.	X-X Axis			Y-Y Axis		
			I in ⁴	S in ³	r in.	I in ⁴	S in ³	r in.
H-132	1.94	0.552	0.188	0.208	0.584	0.236	0.290	0.654

I = Moment of Inertia S = Section Modulus r = Radius of Gyration

Span or Unbraced Height (In)	Static Beam Load (X-X Axis)							Column Loading Data			
	Max Allowable Uniform Load (Lbs)	Deflection at Uniform Load (In)	Uniform Load at Deflection				Max. Allowable Load at Slot Face (Lbs)	Max. Column Load Applied at C.G.			
			Span/180 Deflection (Lbs)	Span/240 Deflection (Lbs)	Span/360 Deflection (Lbs)	Weight of Channel (Lbs)		k=.65 (Lbs)	k=.80 (Lbs)	k=1.0 (Lbs)	k=1.2 (Lbs)
12	3,480	0.01	3,480	3,480	3,480	1.9	3,850	12,240	11,940	11,480	10,960
18	2,320	0.03	2,320	2,320	2,320	2.9	3,710	11,540	10,960	10,130	9,290
24	1,740	0.06	1,740	1,740	1,740	3.9	3,530	10,690	9,850	8,740	7,710
30	1,390	0.09	1,390	1,390	1,310	4.9	3,330	9,780	8,740	7,470	6,380
36	1,160	0.13	1,160	1,160	910	5.8	3,120	8,880	7,710	6,380	5,310
42	990	0.17	990	990	670	6.8	2,910	8,020	6,800	5,470	4,430
48	870	0.23	870	770	510	7.8	2,710	7,240	6,000	4,690	3,810
60	700	0.35	660	490	330	9.7	2,340	5,910	4,690	3,630	2,960
72	580	0.51	460	340	230	11.6	2,040	4,840	3,810	2,960	2,400
84	500	0.69	340	250	170	13.6	1,800	4,040	3,200	2,480	1,980
96	430	0.90	260	190	130	15.5	1,600	3,480	2,750	2,110	1,670
108	390	1.14	200	150	100	17.5	1,440	3,050	2,400	1,820	**
120	350	1.41	160	120	80	19.4	1,290	2,700	2,110	**	**
144	290	2.03	110	90	60	23.3	1,060	2,180	1,670	**	**
168	250	2.77	80	60	40	27.2	**	1,790	**	**	**
180	230	3.18	70	50	40	29.1	**	**	**	**	**
192	220	3.61	60	50	NR	31.0	**	**	**	**	**
216	190	4.57	50	40	NR	34.9	**	**	**	**	**
240	170	5.65	40	NR	NR	38.8	**	**	**	**	**

Bearing Load may limit load

NR = Not Recommended

** Not recommended - KL/r exceeds 200

Notes

- The beam capacities shown above include the weight of the strut beam. The beam weight must be subtracted from these capacities to arrive at the net beam capacity.
- Allowable beam loads are based on a uniformly loaded, simply supported beam. For capacities of a beam loaded at midspan at a single point, multiply the beam capacity by 50% and deflection by 80%.

3. The above chart shows beam capacities for strut without holes. For strut with holes, multiply by the following:

OS by 88%, OS3 by 90%,
 RS (1/16 holes) by 88%, RS-MOD (1/4 holes) by 85%,
 RS3 (1/16 holes) by 88%, RS-MOD2 (1/16 holes) by 88%,
 KO by 82%.

4. Refer to page 52 for reduction factors for unbraced lengths

H-132-OS

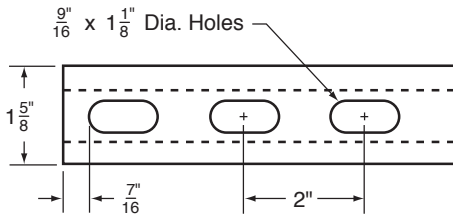
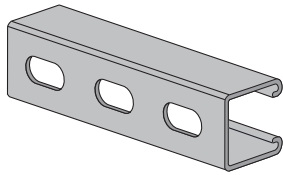

Wt./100 Ft.: 189

H-132-RS3

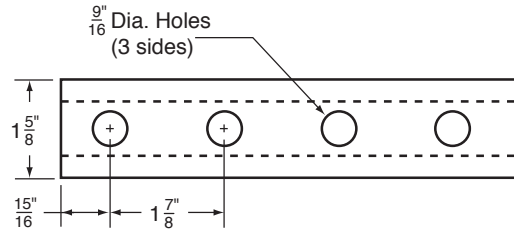
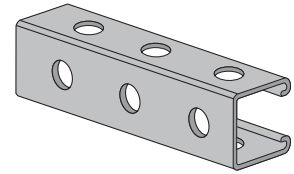

Wt./100 Ft.: 179

H-132-RS

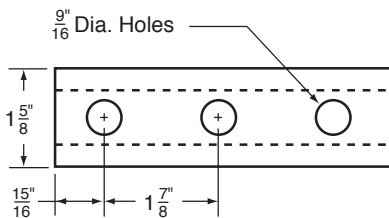
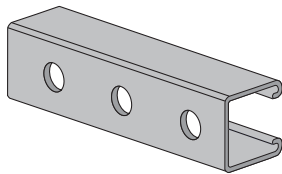

Wt./100 Ft.: 189

H-132-RS-MOD2

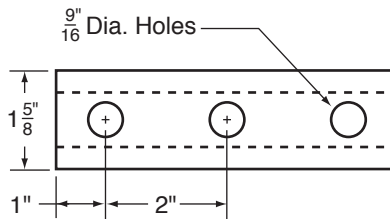
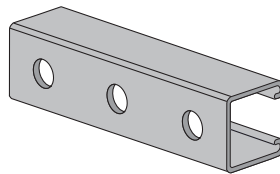

Wt./100 Ft.: 194

H-132-RS-MOD

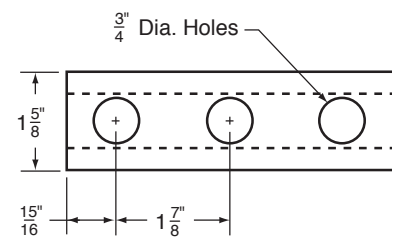
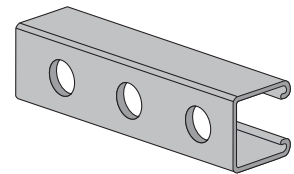

Wt./100 Ft.: 187

H-132-OS3

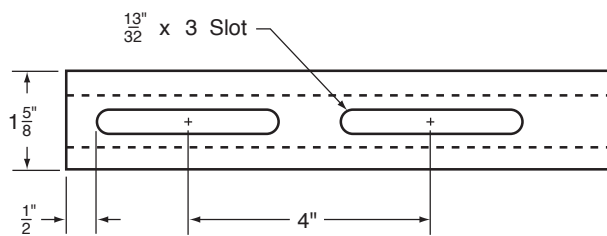
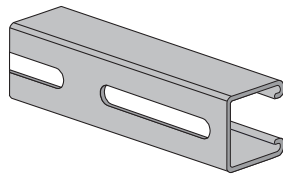

Wt./100 Ft.: 179

H-132-KO

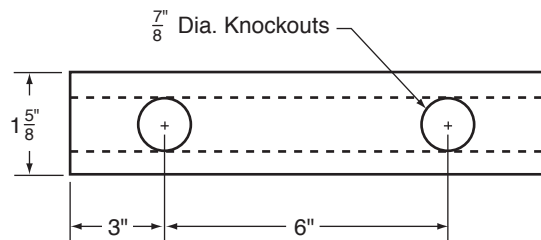
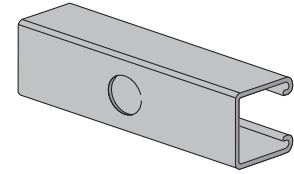

Wt./100 Ft.: 194

THREADED FASTENERS

All-Thread Rod

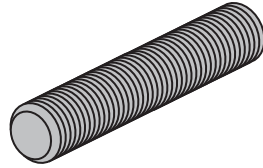

Diameter	Thd.	Wt./100 Ft.
1/4"	20	12
3/8"	16	30
1/2"	13	54
5/8"	11	85
3/4"	10	125

FINISH: Electro-Galvanized/Plain

LENGTH: 6', 10' & 12'

Rod Couplers

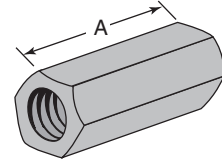

Hole Size	Thd.	"A" Length	Wt./100 Pcs.
1/4"	20	7/8"	2
3/8"	16	1 3/4"	11
1/2"	13	1 3/4"	11
5/8"	11	2 1/8"	16
3/4"	10	2 1/4"	28

FINISH: Electro-Galvanized/Plain

SN

Stud Nut with RS Spring

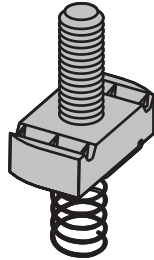

Part No.	Size	Std. Pkg.	Wt./100 Pcs.
SN	1/4" x 1"	100	8.1
SN	1/4" x 1 1/4"	100	8.3
SN	1/4" x 1 1/2"	100	8.6
SN	1/4" x 2"	100	9.1
SN	3/8" x 1"	100	13.0
SN	3/8" x 1 1/4"	100	14.0
SN	3/8" x 1 1/2"	100	14.0
SN	3/8" x 2"	100	15.0
SN	1/2" x 1"	100	15.0
SN	1/2" x 1 1/4"	100	16.0
SN	1/2" x 1 1/2"	100	17.0
SN	1/2" x 2"	100	19.0

Page Notes:

All items UNC
Coarse Thread

N-8771

Double Nut

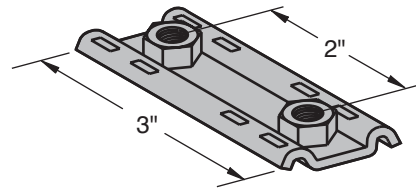

Cat. No.	Size	Thread	Wt./100 Pcs.
N-8771	3/8"	16	175

FINISH: Electro-Galvanized

GRIP LOCK NUTS & HARDWARE

THREADED FASTENERS

Hardware

Lock Washers

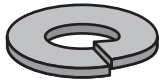

Size	Wt./100 Pcs.
1/4"	0.3
3/8"	0.7
1/2"	1.5

FINISH: Electro-Galvanized

Flat Washers

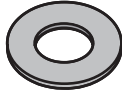

Size	Wt./100 Pcs.
1/4"	0.7
3/8"	1.5
1/2"	3.5

FINISH: Electro-Galvanized

Hex Nuts

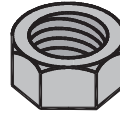

Size	Wt./100 Pcs.
1/4"	0.6
5/16"	1.2
3/8"	1.6
1/2"	4.8

FINISH: Electro-Galvanized

Square Nuts

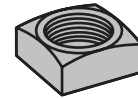

Size	Wt./100 Pcs.
1/4"	0.9
5/16"	1.6
3/8"	2.7
1/2"	5.8

FINISH: Electro-Galvanized

Flat Head Machine Screws

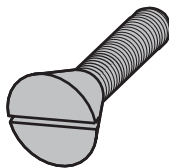

Diameter	Length	Wt./100 Pcs.
1/4"	1/2"	1.2
5/16"	1"	2.6
3/8"	2"	6.5
3/8"	2 1/4"	7.1
3/8"	2 1/2"	7.7

FINISH: Electro-Galvanized

Round Head Machine Screws

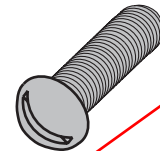

Diameter	Length	Wt./100 Pcs.	Diameter	Length	Wt./100 Pcs.
1/4"	3/4"	1.2	5/16"	1 1/2"	3.6
1/4"	1"	1.5	3/8"	1"	4.1
1/4"	1 1/4"	1.8	3/8"	1 1/4"	4.7
5/16"	1"	2.6	3/8"	1 1/2"	5.3
5/16"	1 1/4"	3.0	3/8"	2 1/2"	7.7

FINISH: Electro-Galvanized

Hex Head Cap Screws

Diameter	Length	Wt./100 Pcs.	Diameter	Length	Wt./100 Pcs.
1/4"	1/2"	1.0	3/8"	2 1/4"	8.5
1/4"	3/4"	1.3	1/2"	1"	9.1
1/4"	1"	1.7	1/2"	1 1/4"	10.0
3/8"	3/4"	4.0	1/2"	1 1/2"	11.6
3/8"	1"	4.5	1/2"	1 3/4"	13.2
3/8"	1 1/4"	5.3	1/2"	2"	14.7
3/8"	1 1/2"	6.1	1/2"	2 1/4"	16.0
3/8"	2"	7.6	1/2"	2 1/2"	17.5

FINISH: Electro-Galvanized

For use with H-Grip Lock Nuts to secure fittings to channels.

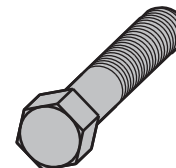

Page Notes:
All items UNC
Coarse Thread

THREADED ROD LOAD RATINGS

Threaded Rod Load Rating			
Nominal Rod Diameter, In.	Root Area Thread, In.	Maximum Safe Load, Lbs Rod Temperatures	
		650°F	750°F
3/8"	0.068	610	540
1/2"	0.128	1,130	1,010
5/8"	0.202	1,810	1,610
3/4"	0.302	2,710	2,420
7/8"	0.419	3,770	3,360
1"	0.552	4,960	4,420
1-1/8"	0.693	6,230	5,560
1-1/4"	0.889	8,000	7,140
1-1/2"	1.293	11,630	10,370
1-3/4"	1.744	15,700	14,000
2"	2.300	20,700	18,460

Rod Size as Determined by Pipe Size	
Pipe Size	Rod Size
3/4" to 2" Inclusive	3/8"
2-1/2" to 3-1/2"	1/2"
4" and 5"	5/8"
6"	3/4"
8" to 12" Inclusive	7/8"

WATER FILLED PIPE WEIGHTS

WATER FILLED PIPE WEIGHTS FOR PIPE HANGERS LOCATED ON 6 FT CENTERS AT 1/4 SPAN FROM EACH END									
SIZE	2"	2-1/2"	3"	4"	5"	6"	8"	10"	12"
SCH 40 PIPE WEIGHT PER FT (LBS)	3.65	5.79	7.57	10.78	14.60	18.95	28.52	40.44	53.47
WATER WEIGHT PER FT (LBS)	1.45	2.07	3.20	5.51	8.67	12.52	21.67	34.16	48.49
TOTAL WEIGHT PER FT (LBS)	5.10	7.86	10.77	16.29	23.27	31.47	50.20	74.60	101.96
PIPE HANGER CENTERS (FT)	6	6	6	6	6	6	6	6	6
TOTAL WEIGHT PER 6 FT CENTER - ONE PIPE (LBS)	31	47	65	98	140	189	301	448	612
TOTAL WEIGHT PER 6 FT CENTER - TWO PIPES (LBS)	61	94	129	196	279	378	602	895	1,223
RECOMMENDED 3 FT SPAN PIPE HANGER TOP BEAM	H-132	H-132	H-132	H-132	H-132	H-132	H-122	H-112	H-112
RECOMMENDED 4 FT SPAN PIPE HANGER TOP BEAM	H-132	H-132	H-132	H-132	H-132	H-122	H-112	H-112	H-122A
RECOMMENDED 5 FT SPAN PIPE HANGER TOP BEAM	H-132	H-132	H-132	H-132	H-122	H-122	H-112	H-122A	H-122A
RECOMMENDED 6 FT SPAN PIPE HANGER TOP BEAM	H-132	H-132	H-132	H-132	H-122	H-122	H-112	H-122A	H-112A

WATER FILLED PIPE WEIGHTS FOR PIPE HANGERS LOCATED ON 8 FT CENTERS AT 1/4 SPAN FROM EACH END									
SIZE	2"	2-1/2"	3"	4"	5"	6"	8"	10"	12"
SCH 40 PIPE WEIGHT PER FT (LBS)	3.65	5.79	7.57	10.78	14.60	18.95	28.52	40.44	53.47
WATER WEIGHT PER FT (LBS)	1.45	2.07	3.20	5.51	8.67	12.52	21.67	34.16	48.49
TOTAL WEIGHT PER FT (LBS)	5.10	7.86	10.77	16.29	23.27	31.47	50.20	74.60	101.96
PIPE HANGER CENTERS (FT)	8	8	8	8	8	8	8	8	8
TOTAL WEIGHT PER 8 FT CENTER - ONE PIPE (LBS)	41	63	86	130	186	252	402	597	816
TOTAL WEIGHT PER 8 FT CENTER - TWO PIPES (LBS)	82	126	172	261	372	504	803	1,194	1,631
RECOMMENDED 3 FT SPAN PIPE HANGER TOP BEAM	H-132	H-132	H-132	H-132	H-132	H-122	H-112	H-112	H-122A
RECOMMENDED 4 FT SPAN PIPE HANGER TOP BEAM	H-132	H-132	H-132	H-132	H-132	H-122	H-112	H-112	H-122A
RECOMMENDED 5 FT SPAN PIPE HANGER TOP BEAM	H-132	H-132	H-132	H-122	H-122	H-112	H-122A	H-122A	H-112A
RECOMMENDED 6 FT SPAN PIPE HANGER TOP BEAM	H-132	H-132	H-132	H-122	H-122	H-112	H-122A	H-112A	H-112A

MAXIMUM SPACING BETWEEN SUPPORTS

Nominal Tube Size, In.	1/2"	3/4"	1"	1 1/2"	2	2 1/2"	3	3 1/2"	4
Maximum Span, Ft.	5	6	6	8	9	10	10	11	12

Nominal Pipe Size, In.	Maximum Span, Ft.	1/2"	3/4"	1"	1 1/2"	2	2 1/2"	3	3 1/2"	4	5	6	8	10	12	14	16	18	20	24
		Water	5	6	7	9	10	11	12	13	14	14	16	17	19	22	23	25	27	28
Air & Steam	-	-	9	11	13	14	15	16	17	17	19	21	24	28	30	32	35	37	39	42

CADDY® SLICK NUT

- Provides fast universal attachment of threaded rod and hardware to standard strut profiles



Material:
Finish: CADDY® ARMOUR

Part Number	Description	F1	F2	F3
SLICK250	1/4" Hole, Threaded	400 lb	100 lb	250 lb
SLICK375	3/8" Hole, Threaded	600 lb	100 lb	250 lb
SLICK500	1/2" Hole, Threaded	600 lb	100 lb	250 lb

Indicated loads are independent of the threaded stud or rod.
Indicated loads are applicable on 14 GA and 12 GA (2 mm and 2.5 mm) strut channels only.

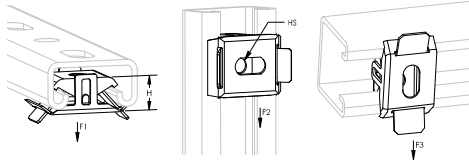

CADDY® ERISTRUT

Strut Nut with Spring, Channel Type A



Material: Steel
Finish: Electrogalvanized

Part Number	Description	Torque
SPRA0025EG	EG, 1/4" Rod	6 ft lb
SPRA0037EG	EG, 3/8" Rod	19 ft lb
SPRA0050EG	EG, 1/2" Rod	50 ft lb
SPRA0062EG	EG, 5/8" Rod	50 ft lb

Part Number	Pull-Out Strength	
	Channel Thickness	
	12 GA	14 GA
SPRA0025EG	450 lb	450 lb
SPRA0037EG	1,100 lb	1,000 lb
SPRA0050EG	2,000 lb	1,400 lb
SPRA0062EG	2,000 lb	1,400 lb

Strut Nut with Spring, Channel Type C



Material: Steel
Finish: Electrogalvanized

Part Number	Description	Torque
SPRC0025EG	EG, 1/4" Rod	6 ft lb
SPRC0037EG	EG, 3/8" Rod	19 ft lb

Part Number	Pull-Out Strength	
	Channel Thickness	
	12 GA	14 GA
SPRC0025EG	450 lb	450 lb
SPRC0037EG	1,100 lb	1,000 lb

Strut Nut with Top Spring



Material: Steel
Finish: Electrogalvanized

Part Number	Description	Torque
TSNT0025EG	EG, 1/4" Rod	6 ft lb
TSNT0037EG	EG, 3/8" Rod	19 ft lb
TSNT0050EG	EG, 1/2" Rod	50 ft lb

Part Number	Channel Type	Pull-Out Strength	
		Channel Thickness	
		12 GA	14 GA
TSNT0025EG	A, C	450 lb	450 lb
	D, E	450 lb	-
TSNT0037EG	A, C	1,100 lb	1,000 lb
	D, E	1,100 lb	-
TSNT0050EG	A	2,000 lb	1,400 lb
	D, E	1,500 lb	-



CADDY® ERISTRUT

Strut Nut without Spring



Part Number	Description	Torque
Material: Stainless Steel 316		
NUT003756	S316, 3/8" Rod	19 ft lb
NUT005056	S316, 1/2" Rod	50 ft lb
Material: Steel — Finish: Electrogalvanized		
NUT0025EG	EG, 1/4" Rod	6 ft lb
NUT0037EG	EG, 3/8" Rod	19 ft lb
NUT0050EG	EG, 1/2" Rod	50 ft lb
NUT0062EG	EG, 5/8" Rod	50 ft lb
NUT0075EG	EG, 3/4" Rod	50 ft lb

Part Number	Channel Type	Pull-Out Strength	
		Channel Thickness	
		12 GA	14 GA
NUT0025xx	A, C	450 lb	450 lb
	D, E	450 lb	-
NUT0037xx	A, C	1,100 lb	1,000 lb
	D, E	1,100 lb	-
NUT0050xx	A	2,000 lb	1,400 lb
	D, E	1,500 lb	-
NUT0062xx	A	2,000 lb	1,400 lb
	D, E	1,500 lb	-
NUT0075xx	A	2,000 lb	1,400 lb
	D, E	1,500 lb	-

Strut to Strut Connector



- Consists of two half castings, nut and bolt
- Allows for bolting two strut channels back to back through the slots

Material: Steel
Finish: Electrogalvanized

Part Number	Description	F
STS	Strut to Strut Connector	1,000 lb

Minimum of 2 required. Maximum spacing 1 foot (300mm).

Clip-On Strut Nut

- Easily snaps into strut using a screwdriver



Material: Spring Steel
Finish: CADDY® ARMOUR



Part Number	Description	F1	F2
MFA4I	1/4" Hole, Threaded	100 lb	40 lb
MFA625	1/4" Hole, w/Screw, 5/8" Screw Length	100 lb	40 lb

Strut Cantilever Arm Type A, Slotted

- Slotted channel
- Welded on flat mounting plate



Material: Steel
Finish: Electrogalvanized

Part Number	Description
KA25H0150EG	EG, 6" x 1 5/8" x 1 5/8" x 0.098"
KA25H0300EG	EG, 11 7/8" x 1 5/8" x 1 5/8" x 0.098"
KA25H0450EG	EG, 17 3/4" x 1 5/8" x 1 5/8" x 0.098"
KA25H0600EG	EG, 23 5/8" x 1 5/8" x 1 5/8" x 0.098"



Square Channel Washer



Material: Steel
Finish: Electrogalvanized

Part Number	Description
F130000EG	EG, 5/16" Rod, 3/8" Hole
F140000EG	EG, 3/8" Rod, 7/16" Hole
F150000EG	EG, 1/2" Rod, 9/16" Hole
F160000EG	EG, 5/8" Rod, 1 1/16" Hole
F170000EG	EG, 3/4" Rod, 13/16" Hole
F180000EG	EG, 7/8" Rod, 15/16" Hole

Two Hole Flat Bracket



Material: Steel
Finish: Electrogalvanized

Part Number	Description
F090000EG	EG, 3 1/2"
F220000EG	EG, 3 1/4"

Three Hole Flat Bracket

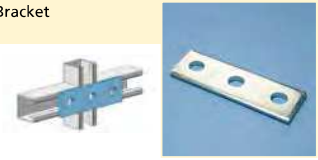

Material: Steel
Finish: Electrogalvanized

Part Number	Description
F200000EG	EG, 5 3/8"

Three Hole Flat Corner Bracket



Material: Steel
Finish: Electrogalvanized

Part Number	Description
F360000EG	EG, 3 1/2" x 3 1/2"



Four Hole Flat Bracket



Material: Steel
Finish: Electrogalvanized

Part Number	Description
F230000EG	EG, 7 1/4"

Four Hole Flat Corner Bracket



Material: Steel
Finish: Electrogalvanized

Part Number	Description
F370000EG	3 1/2" x 5 3/8"

Four Hole Flat Tee Plate



Material: Steel
Finish: Electrogalvanized

Part Number	Description
F250000EG	EG, 5 3/8" x 3 1/2"

1-1 Hole Angle Bracket



Part Number	Description
Material: Stainless Steel 304	
L11000S4	S304, 2" x 1 7/8"
Material: Steel — Finish: Electrogalvanized	
L10000EG	EG, 2 1/4" x 1 5/8"
L11000EG	EG, 2" x 1 7/8"

1-1 Hole Unequal Long Angle Bracket



Material: Steel
Finish: Electrogalvanized

Part Number	Description
L120300EG	3" x 1 7/8"

2-2 Hole Corner Angle Bracket



Material: Steel
Finish: Electrogalvanized

Part Number	Description
L220000EG	EG, 4 1/8" x 3 1/2"

3-3-1 Hole Corner Gusset



Material: Steel
Finish: Electrogalvanized

Part Number	Description
L23U0000EG	4 1/8" x 4 1/8"



1-2 Hole Corner Short Angle Bracket



Material: Steel
Finish: Electrogalvanized

Part Number	Description
L190000EG	EG, 3 7/8" x 1 7/8"
L200000EG	EG, 4 1/8" x 1 5/8"

1-2 Hole Corner Angle Bracket

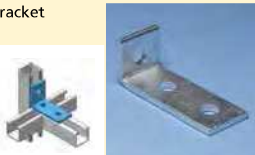

Material: Steel
Finish: Electrogalvanized

Part Number	Description
L180000EG	EG, 3 1/2" x 2 1/2"



1-1 Hole Open Corner Angle Bracket



Material: Steel
Finish: Electrogalvanized

Part Number	Description
L460450EG	EG, 3 5/32" x 2 1/4"

1-1 Hole Closed Corner Angle Bracket

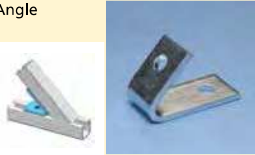

Material: Steel
Finish: Electrogalvanized

Part Number	Description
L470450EG	EG, 45° Angle, 3 1/2" x 2 1/2"

2 Hole 45° Angle Brace



Material: Steel
Finish: Electrogalvanized

Part Number	Description
L441200EG	EG, 12" x 10 1/2"
L441600EG	EG, 16" x 13 5/16"

Six Hole Corner Connector, 3-Way



Material: Steel
Finish: Electrogalvanized

Part Number	Description
W190000EG	1 5/8" x 5 7/16" x 2"

Eight Hole Double Corner Connector, 3-Way



Material: Steel
Finish: Electrogalvanized

Part Number	Description
W170000EG	EG, 1 5/8" x 5 1/2" x 4"

45° Post Base for Strut Type A

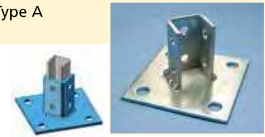

- Post base to create metal frames for attachment to CADDY® ERISTRUT or CADDY® PYRAMID

Material: Steel
Finish: Electrogalvanized

Part Number	Description
P110000EG	EG, 6" x 6" x 3 1/2"

45° Post Base for Strut Type AA



- Post base to create metal frames for attachment to CADDY® ERISTRUT or CADDY® PYRAMID

Material: Steel
Finish: Electrogalvanized

Part Number	Description
P130000EG	EG, 6" x 3 1/2"

Strut Beam Clamp with U-Bolt



- Square U-bolt type beam clamp
- Complete with U-bolt and nuts
- Requires installation in pairs

Material: Steel
Finish: Electrogalvanized

Part Number	Description	F ↓
BC17A000EG	EG, A, C Strut	1,200 lb
BC17D000EG	EG, AA, D, E Strut	1,200 lb

Static Load is based on one pair of Strut Beam Clamps.



Nine Hole Corner Connector, 3-Way



Material: Steel
Finish: Electrogalvanized

Part Number	Description
W200000EG	EG, 3 1/2" x 5 7/16" x 3 3/4"

Four Hole External Coupler



Material: Steel
Finish: Electrogalvanized

Part Number	Description
U24A0000EG	EG, A Strut

Rectangular Post Base Plate



Material: Steel
Finish: Hot-Dip Galvanized

Part Number	Description
ZGA512	3.94" x 6.3" x 3.15"

Strut Beam Clamp with Bolt, Window Shape



- Complete with bolt
- Requires installation in pairs

Material: Steel
Finish: Electrogalvanized

Part Number	Description	F ↓
BC16A000EG	EG, A, CC Strut	740 lb

Strut Beam Clip



- Beam Clip for clamping the open side of strut to a beam
- Suitable for all strut channels
- Requires installation in pairs
- Structural attachment to beams to support CADDY® ERISTRUT

Material: Steel
Finish: Electrogalvanized

Part Number	Description	F ↓
BC200000EG	EG, 1/2" Flange, 9/16" Hole	460 lb

Indicated loads are based on installation with 1/2" (M12) hardware and strut channel type A.

Strut Beam Clamp with Bolt



- Beam clip for mounting on open side of strut
- Bolt included
- Requires installation in pairs

Material: Steel
Finish: Electrogalvanized

Part Number	Description	F ↓
BC210000EG	1" Flange, 9/16" Hole	460 lb

Internal Strut Beam Clamp with Bolt

- U-shaped clip for clamping the back of strut channel to a beam
- Hex bolt included
- Requires installation in pairs



Material: Steel
Finish: Electrogalvanized

Part Number	Description	F
BC180037EG	EG, 3/8" Screw	660 lb
BC180050EG	EG, 1/2" Screw	660 lb

Static Load is based on one pair of Strut Beam Clamps.
Include strut channel thickness when calculating flange thickness.

Strut and Rod Beam Clamp

- Multifunctional beam clamp suitable for strut channel or threaded rod
- Bolt included
- Requires installation in pairs



Material: Steel
Finish: Electrogalvanized



Part Number	Description	F
STCB6	EG, 3/8" Rod, 2" Max Flange	400 lb



BC23 Internal Strut Beam Clamp

- Kit of two inserts for A type channel
- Complete with pointed head hex bolts for easy installation



Material: Steel
Finish: Electrogalvanized

Part Number	Description	F
BC23A000EG	A Strut	800 lb

INC8 Internal Strut Beam Clamp

- Mounts strut within vertical beams



Material: Spring Steel
Finish: CADDY® ARMOUR

Part Number	Description	F	pc
INC8T5	A Strut	100 lb	100 pc

Strut Trapeze Attachment Plate

- Creates fast install trapeze brackets
- Includes hex bolt and strut nut



Material: Steel
Finish: Electrogalvanized

Part Number	Description
J5SP375	3/8" Rod

Strut Trapeze Attachment Kit

- Kit includes 2 strut trapeze attachment plates and 4 SN series nuts
- Creates fast install trapeze brackets



Material: Steel
Finish: Electrogalvanized

Part Number	Description	F
J5SPK	3/8" Rod	220 lb

Static Load is based on one pair of strut trapeze attachment plates.

Strut Trolley, One Axle

- Fits in A channel or higher



Material: Steel
Finish: Electrogalvanized

Part Number	Description
ROL10000EG	Strut Trolley, One Axle



Strut Trolley, Two Axles

- Fits in A channel or higher



Material: Steel
Finish: Electrogalvanized

Part Number	Description
ROL11000EG	Strut Trolley, Two Axles

SAA Slotted Framing Angle, Equal Leg

- Cold formed, slotted



Material: Steel
Finish: Electrogalvanized

Part Number	Description
SAA1400EG	10'

SAD Slotted Framing Angle, Unequal Leg

- Cold formed, slotted



Material: Steel
Finish: Electrogalvanized

Part Number	Description
SAD1400EG	10'

Structural Attachments – Wall/Ceiling

365 Steel Wall or Ceiling Plate

- Structural attachment to support hanger rod from a ceiling or a wall



Material: Steel

Part Number	Description	F
Finish: Copper Electroplated		
3650037CP	CP, 3/8" Rod	100 lb
Finish: Electrogalvanized		
3650037EG	EG, 3/8" Rod	100 lb
Finish: Plain		
3650037PL	3/8" Rod	100 lb

Follow fastener manufacturer's recommended shear and pull-out strength when fastening to the structure. Fastener not included.

365M Malleable Iron Wall or Ceiling Plate

- Structural attachment to support hanger rod from a ceiling or a wall



Material: Cast Iron

Part Number	Description	F
Finish: Copper Electroplated		
365M0037CP	CP, 3/8" Rod	180 lb
365M0050CP	CP, 1/2" Rod	180 lb
Finish: Electrogalvanized		
365M0037EG	EG, 3/8" Rod	180 lb
365M0050EG	EG, 1/2" Rod	180 lb
Finish: Plain		
365M0037PL	3/8" Rod	180 lb
365M0050PL	1/2" Rod	180 lb

Follow fastener manufacturer's recommended shear and pull-out strength when fastening to the structure. Fastener not included.



174

Ph: 1-800-25-CADDY
www.erico.com

Structural Attachments – Wall/Ceiling

348 Light Duty Welded Wall Bracket

- Wall attachment to suspend 2" or smaller static piping



Material: Steel
Finish: Plain

Part Number	Description	F
3480100PL	1/2" Rod, 9"	750 lb
3480200PL	1/2" Rod, 13"	750 lb
3480300PL	1/2" Rod, 19"	750 lb

Follow fastener manufacturer's recommended shear and pull-out strength when fastening to the structure. Fastener not included.

352 Standard Duty Welded Wall Bracket

- Wall attachment to support or suspend static piping
- Conforms with Federal Specification WW-H-171 (Type 32), Manufacturers Standardization Society ANSI/MSS-SP-58 (Type 32)



Material: Steel
Finish: Plain

Part Number	Description	F
3520100PL	18"	1,500 lb
3520200PL	24"	1,500 lb
3520300PL	30"	1,500 lb

Follow fastener manufacturer's recommended shear and pull-out strength when fastening to the structure. Fastener not included.
Install in accordance with applicable code.



176

Ph: 1-800-25-CADDY
www.erico.com

Structural Attachments – Wall/Ceiling

Angle Bracket

- Permits wire or chain drops from concrete or wood



Material: Steel
Finish: Pregalvanized



Part Number	Description	F
AB	PG, 1/4" Hole 1, 1/4" Hole 2	160 lb
AB375	PG, 1/4" Hole 1, 3/8" Hole 2	160 lb

Pin Driven Angle Bracket

- Longer leg angle bracket for tool clearance
- Designed to fit a variety of pin drivers
- Improved for easier installation with pin drivers
- Preassembly options available for rod, wire, strap and cable applications



Structural Attachments – Wall/Ceiling

Material: Steel
Finish: Pregalvanized



Part Number	Description	F
AFAB3	3/16" Hole	160 lb
AFAB4	1/4" Hole	350 lb
AFAB6	3/8" Hole	350 lb

Load limits apply to CADDY® Fasteners only.
Pin must be evaluated separately.

Structural Attachments – Wall/Ceiling

353 Heavy Duty Welded Wall Bracket

- Wall attachment to support or suspend static piping
- Conforms with Federal Specification WW-H-171 (Type 33), Manufacturers Standardization Society ANSI/MSS-SP-58 (Type 33)



Material: Steel
Finish: Plain

Part Number	Description	F
3530100PL	18"	3,000 lb
3530200PL	24"	3,000 lb
3530300PL	30"	3,000 lb
3530400PL	36"	3,000 lb

Follow fastener manufacturer's recommended shear and pull-out strength when fastening to the structure. Fastener not included.
Install in accordance with applicable code.

Triangular Wall Bracket, Four/Three Hole

- Triangular shaped welded bracket manufactured from hot rolled steel
- Perforated on two sides
- Suitable for installation in two directions



Structural Attachments – Wall/Ceiling

Material: Steel
Finish: Hot-Dip Galvanized

Part Number	Description	F1	F2
SCT02	9.45" x 12.4"	899 lb	1,798 lb

Structural Attachments – Wall/Ceiling

Triangular Wall Bracket, Four/Two Hole

- Triangular shaped welded bracket manufactured from hot rolled steel
- Perforated on two sides
- Suitable for installation in two directions



Material: Steel
Finish: Hot-Dip Galvanized

Part Number	Description	F1	F2
SCT03	13.78" x 21.65"	899 lb	1,798 lb

Structural Attachments – Wall/Ceiling



178

Ph: 1-800-25-CADDY
www.erico.com

Structural Attachments – Beam

BC09 Retainer Strap for BC13/14 Series

- Retainer strap for BC13/BC14 beam clamps



Structural Attachments – Beam

Material: Steel
Finish: ElectroGalvanized

Part Number	Description
BC090900EG	9"
BC091200EG	12"
BC091500EG	15"

360 Adjustable Center-Load Beam Clamp

- Beam clamp without extension piece
- Use with Series 26 Beam Clamp Extension Piece, Series 35 Heavy Duty Eye Nut or Series 40 Eye Rod (not included)



Material: Steel

Part Number	Description
Finish: ElectroGalvanized	
3600000EG	EG
Finish: Plain	
3600000PL	Plain

Install in accordance with applicable code.

Structural Attachments – Beam

360 Adjustable Center-Load Beam Clamp Kit

- Includes Series 26 Beam Clamp Extension Piece



Material: Steel
Finish: Plain

Part Number	Description	F
3600037PL	3/8" Rod, 2" Max Pipe	610 lb
3600050PL	1/2" Rod, 3 1/2" Max Pipe	1,130 lb
3600062PL	5/8" Rod, 5" Max Pipe	1,365 lb
3600075PL	3/4" Rod, 6" Max Pipe	1,365 lb
3600087PL	7/8" Rod, 12" Max Pipe	1,365 lb

Reduced hanger spacing is required when supporting 10" and 12" pipe. Install in accordance with applicable code.

363 Adjustable Center-Load Beam Clamp with J-Bolt

- Adjustable beam clamp
- Conforms with Federal Specification WW-H-171 (Type 54), Manufacturers Standardization Society ANSI/MSS-SP-58 (Type 27)



Material: Steel
Finish: Plain

Part Number	Description	F
3630037PL	3/8" Rod	300 lb
3630050PL	1/2" Rod	700 lb
3630062PL	5/8" Rod	1,000 lb
3630075PL	3/4" Rod	1,000 lb



156

Ph: 1-800-25-CADDY
www.erico.com

Structural Attachments – Beam

SBC Stamped Beam Clamp, Top Mount

- Allows structural attachment to metal beams, bar joist, channel, or angle iron in top mount position only unless used on a parallel flange
- Lightweight, one-piece stamped body provides superior strength and eliminates deficiencies associated with castings
- Spins onto threaded rod and allows for easy adjustment
- Conforms with Federal Specification WW-H-171 (Type 23), Manufacturers Standardization Society ANSI/MSS-SP-58 (Type 19)



Material: Steel
Finish: Pregalvanized



Part Number	Description	F
SBC037	3/8" Rod, 3/4" Max Flange	500 lb

Set screw must be tightened and torqued onto the sloped side of the I-beam, channel, or angle iron flange. Recognizing that torque wrenches are generally not used or available on many job sites, the setscrew should be tightened so it contacts the I-beam and then an additional 1/4 to 1/2 turn added.

300 Universal Beam Clamp

- Conforms with Federal Specification WW-H-171 (Type 23), Manufacturers Standardization Society ANSI/MSS-SP-58 (Type 19 and 23)



Material: Steel



Part Number	Description	F1	F2	Certifications
Finish: ElectroGalvanized				
3000037EG	EG, 3/8" Rod, 13/16" Max Flange	500 lb	250 lb	100 pc --
3000050EG	EG, 1/2" Rod, 13/16" Max Flange	950 lb	760 lb	50 pc --
3000062EG	EG, 5/8" Rod, 13/16" Max Flange	950 lb	760 lb	50 pc cULus
3000075EG	EG, 3/4" Rod, 13/16" Max Flange	950 lb	760 lb	50 pc cULus
3000087EG	EG, 7/8" Rod, 13/16" Max Flange	950 lb	760 lb	50 pc cULus
Finish: Plain				
3000037PL	3/8" Rod, 13/16" Max Flange	500 lb	250 lb	100 pc --
3000050PL	1/2" Rod, 13/16" Max Flange	950 lb	760 lb	50 pc --
3000062PL	5/8" Rod, 13/16" Max Flange	950 lb	760 lb	50 pc cULus
3000075PL	3/4" Rod, 13/16" Max Flange	950 lb	760 lb	50 pc cULus
3000087PL	7/8" Rod, 13/16" Max Flange	950 lb	760 lb	50 pc cULus

Set screw must be tightened and torqued onto the sloped side of the I-beam. Recognizing that torque wrenches are generally not used or available on many job sites, the setscrew should be tightened so it contacts the I-beam and then an additional 1/4 to 1/2 turn added.



Structural Attachments – Beam

310 Universal Beam Clamp, Thick Flange

- Universal beam clamp for thick beams
- Conforms with Federal Specification WW-H-171 (Type 23), Manufacturers Standardization Society ANSI/MSS-SP-58 (Type 19 and 23)



Structural Attachments – Beam

Material: Steel

Part Number	Description	F1	F2	
Finish: Electrogalvanized				
3100037EG	EG, 3/8" Rod, 1 1/4" Max Flange	500 lb	250 lb	50 pc
3100050EG	EG, 1/2" Rod, 1 1/4" Max Flange	950 lb	760 lb	50 pc
Finish: Plain				
3100037PL	3/8" Rod, 1 1/4" Max Flange	500 lb	250 lb	50 pc
3100050PL	1/2" Rod, 1 1/4" Max Flange	950 lb	760 lb	50 pc

Setscrew must be tightened and torqued onto the sloped side of the I-beam. Recognizing that torque wrenches are generally not used or available on many job sites, the setscrew should be tightened so it contacts the I-beam and then an additional 1/4 to 1/2 turn added.

BC26 Universal Beam Clamp with Tapped Hole

- One thru-hole for easier installation of threaded rod
- Conforms with Federal Specification WW-H-171 (Type 23), Manufacturers Standardization Society ANSI/MSS-SP-58 (Type 19 and 23)



Material: Steel

Finish: Electrogalvanized

Part Number	Description	F1	F2
BC260025EG	1/4" Rod, 1/4" Hole, Threaded	100 lb	250 lb

Setscrew must be tightened and torqued onto the sloped side of the I-beam. Recognizing that torque wrenches are generally not used or available on many job sites, the setscrew should be tightened so it contacts the I-beam and then an additional 1/4 to 1/2 turn added.

Ph: 1-800-25-CADDY
www.erico.com

147

ERICO

Structural Attachments – Beam

305 Stainless Steel Beam Clamp, Top Mount

- Pressed steel beam clamp
- Structural attachment to top flange of metal beams, purlins, channel, or angle iron
- Conforms with Federal Specification WW-H-171 (Type 23), Manufacturers Standardization Society ANSI/MSS-SP-58 (Type 19)



Material: Stainless Steel 304

Part Number	Description	F
305003754	3/8" Rod, 5/8" Max Flange	500 lb
305005054	1/2" Rod, 5/8" Max Flange	1,130 lb

Set screw must be tightened and torqued onto the sloped side of the I-beam, channel, or angle iron flange. Recognizing that torque wrenches are generally not used or available on many job sites, the setscrew should be tightened so it contacts the I-beam and then an additional 1/4 to 1/2 turn added.

BC Beam Clamp

- Easy installation to beam flanges



Material: Spring Steel
Finish: CADDY[®] ARMOUR

Part Number	Description	F	
BC	1/4" Rod, 7/16" Hole, 1/2" Max Flange	100 lb	100 pc

Setscrew must be tightened and torqued onto the sloped side of the I-beam.



148

Ph: 1-800-25-CADDY
www.erico.com

CADDY[®] ROD LOCK

CADDY[®] ROD LOCK Beam Clamp

- Prefabricated assemblies easily lift and lock into place, helping to save time and money
- Easy "push-to-install" design allows installers to simply push the threaded rod through the mounting hole, instantly holding it in position
- Lock nut can be finger tightened, locking the rod in place
- Works with slightly damaged threads and minor burrs on the threaded rod
- Conforms with Federal Specification WW-H-171 (Type 23), Manufacturers Standardization Society ANSI/MSS-SP-58 (Type 19 and 23)



Patent No.: 8,132,767
8,434,725

Material: Cast Iron

Finish: Electrogalvanized

Part Number	Description	F1*	F2*
CRLB37EG	3/8" Rod, 1/8"-3/8" Flange	250 lb	500 lb

*Static Load 1 represents 1/8" to 3/16" (3 mm to 5 mm) flange thickness. Static Load 2 represents 1/4" to 3/8" (6 mm to 10 mm) flange thickness. For use on plain and electro zinc plated hardware only. Recognizing that torque wrenches are generally not used or available on many job sites, the setscrew should be tightened so it contacts the I-beam and then an additional 1/2 turn added.

CADDY[®] ROD LOCK Beam Clamp, Thick Flange

- Prefabricated assemblies easily lift and lock into place, helping to save time and money
- Easy "push-to-install" design allows installers to simply push the threaded rod through the mounting hole, instantly holding it in position
- Lock nut can be finger tightened, locking the rod in place
- Works with slightly damaged threads and minor burrs on the threaded rod
- Conforms with Federal Specification WW-H-171 (Type 23), Manufacturers Standardization Society ANSI/MSS-SP-58 (Type 19 and 23)



Patent No.: 8,132,767
8,434,725

Material: Cast Iron

Finish: Electrogalvanized

Part Number	Description	F
CRLB50EG	1/2" Rod, 3/8"-3/4" Flange	1,100 lb

FM[®] Approved for top mount applications only. For use on plain and electro zinc plated hardware only. Recognizing that torque wrenches are generally not used or available on many job sites, the setscrew should be tightened so it contacts the I-beam and then an additional 1/2 turn added.



138

Ph: 1-800-25-CADDY
www.erico.com

CADDY[®] ROD LOCK

CADDY[®] ROD LOCK Anchor Screw

- For use with concrete and solid brick
- Prefabricated assemblies easily lift and lock into place, helping to save time and money
- Works with slightly damaged threads and minor burrs on the threaded rod



Patent No.: 8,132,767
8,434,725

Material: Steel

Finish: Electrogalvanized

Part Number	Description	F
CRLA37EG	3/8" Rod, 2 7/8" x 1 1/4" x 7/8"	660 lb

For use on plain and electro zinc plated hardware only. Tested in 3000 psi (20.67 MPa) concrete.

CADDY[®] ROD LOCK Plywood Form Preset Anchor

- Eliminate overhead drilling into building structure – CADDY[®] ROD LOCK Preset Anchors are cast in place
- Nails hold the anchor in place during the pour and easily break off with a strike of a hammer once the plywood forms are removed
- Easy "push-to-install" design allows installers to simply push the threaded rod through the mounting hole, instantly holding it in position
- Works with slightly damaged threads and minor burrs on the threaded rod
- Prefabricated assemblies easily lift and lock into place, helping to save time and money
- Plastic flange acts as insert locator when the forms are removed
- Suitable for use in seismic zones



Patent No.: 8,132,767
8,434,725
Patent Pending

Material: Steel

Finish: Electrogalvanized

Part Number	Description	F
CRLW37EG	3/8" Rod	1,407 lb
CRLW50EG	1/2" Rod	1,605 lb

Ph: 1-800-25-CADDY
www.erico.com

139

ERICO

CADDY[®] ROD LOCK

CADDY® ROD LOCK

CADDY® ROD LOCK Nut

- Easy "push-to-install" design allows installers to simply push the threaded rod through the mounting hole, instantly holding it in position
- Fast installation onto long threaded rods – push the nut in place instead of threading it up the rod
- Excellent alignment and easy fine adjustment by spinning the nut
- Extremely useful in tight spaces where wrenches are difficult to use



Patent No.: 8,132,767
8,434,725
Patent Pending

Material: Steel
Finish: Electrogalvanized

Part Number	Description	F
CRLN37EG	3/8" Rod	1,350 lb

SN Series Nut

- Allows side mounting of nut to threaded rod
- Reduces the need for threading compared to standard nuts and washers
- Ideal for retrofit projects, such as trapeze installations
- Works with slightly damaged threads and minor burrs on the threaded rod
- Reduces installation time up to 50%



Material: Steel
Finish: Electrogalvanized

Part Number	Description	F
SN25	1/4" Rod	500 lb
SN37	3/8" Rod	1,350 lb
SN50	1/2" Rod	2,250 lb

For use on plain and electro zinc plated hardware only.

CADDY® ROD LOCK

CADDY® ROD LOCK Top-Mount Duct Bracket

- Allows duct to be mounted tight against the ceiling to maximize overhead space and reduce the amount of threaded rod required
- Multiple horizontal mounting slots accommodate insulated duct in tight spaces
- Works with studs in addition to threaded rods for a more aesthetic installation
- Slotted holes in bracket allow for horizontal adjustment of the bracket relative to the duct
- Easy "push-to-install" design allows installers to simply push the threaded rod through the mounting hole, instantly holding it in position
- Ready to use out of the box and eliminates the need for cutting and preparing sections of strut, angle iron, or strap
- Integrated adjustment nut enables fine tuning the system height up or down
- Lock nut can be finger tightened, locking the rod in place
- Ideal for modular assembly – allows attachment of brackets to sections of duct while safely on the ground
- Extremely useful in tight spaces where wrenches are difficult to use



Patent No.: 8,132,767
8,434,725
Patent Pending

Includes self-tapping sheet metal screws to attach bracket to duct

Material: Steel
Finish: Electrogalvanized

Part Number	Description	F
CRLD37TEG	3/8" Rod	650 lb



CADDY® ROD LOCK



140

Ph: 1-800-25-CADDY
www.erico.com

CADDY® ROD LOCK

CADDY® ROD LOCK Bottom-Mount Duct Bracket

- Ideal for modular assembly – allows attachment of brackets to sections of duct while safely on the ground
- Slotted holes in bracket allow for horizontal adjustment of the bracket relative to the duct
- Easy "push-to-install" design allows installers to simply push the threaded rod through the mounting hole, instantly holding it in position
- Ready to use out of the box and eliminates the need for cutting and preparing sections of strut, angle iron, or strap
- Integrated adjustment nut enables fine tuning the system height up or down
- Lock nut can be finger tightened, locking the rod in place
- Extremely useful in tight spaces where wrenches are difficult to use



Patent No.: 8,132,767
8,434,725
Patent Pending

Includes self-tapping sheet metal screws to attach bracket to duct

Material: Steel
Finish: Electrogalvanized

Part Number	Description	F
CRLD37BEG	3/8" Rod	650 lb



CADDY® ROD LOCK Bottom-Mount Duct Bracket, Narrow

- Ideal for modular assembly – allows attachment of brackets to sections of duct while safely on the ground
- Non-slotted bracket allows for attachment after the final horizontal position of the duct is achieved
- Easy "push-to-install" design allows installers to simply push the threaded rod through the mounting hole, instantly holding it in position
- Ready to use out of the box and eliminates the need for cutting and preparing sections of strut, angle iron, or strap
- Integrated adjustment nut enables fine tuning the system height up or down
- Lock nut can be finger tightened, locking the rod in place
- Extremely useful in tight spaces where wrenches are difficult to use



Patent No.: 8,132,767
8,434,725
Patent Pending

Includes self-tapping sheet metal screws to attach bracket to duct

Material: Steel
Finish: Electrogalvanized

Part Number	Description	F
CRLD37BNEG	3/8" Rod	1,400 lb



Ph: 1-800-25-CADDY
www.erico.com

141

ERICO

CADDY® ROD LOCK

CADDY® ROD LOCK



142

Ph: 1-800-25-CADDY
www.erico.com

CADDY® ROD LOCK

CADDY® ROD LOCK L-Bracket

- Easy "push-to-install" design allows installers to simply push the threaded rod through the mounting hole, instantly holding it in position
- Prefabricated assemblies easily lift and lock into place, helping to save time and money
- Multiple attachment holes support the use of either self-drilling screws or bolts, offering installation options for concrete, wood, and steel structures
- Lock nut can be finger tightened, locking the rod in place
- Integrated adjustment nut enables fine tuning the system height up or down
- Extremely useful in tight spaces where wrenches are difficult to use
- Conforms with Federal Specification WW-H-171 (Type 23), Manufacturers Standardization Society ANSI/MSS-SP-58 (Type 19 and 23)



Patent No.: 8,132,767
8,434,725
Patent Pending

Material: Steel
Finish: Electrogalvanized

Part Number	Description	F
CRLL37EG	3/8" Rod	700 lb



Follow fastener manufacturer's recommended shear and pull-out strength when fastening to the structure. Fastener not included.
Install in accordance with applicable code.

CADDY® ROD LOCK Channel Nut

- Provides fast universal attachment of threaded rod and hardware to standard strut profiles
- Can be used to prefabricate assemblies which can be quickly pushed onto previously installed threaded rods
- Works with slightly damaged threads and minor burrs on the threaded rod



Patent No.: 8,132,767
8,434,725

Material: Cast Iron
Finish: Electrogalvanized

Part Number	Description	F
CRLS37EG	3/8" Rod	750 lb

For use on plain and electro zinc plated hardware only.

Ph: 1-800-25-CADDY
www.erico.com

143

ERICO

CADDY® ROD LOCK

CADDY® ROD LOCK Strut, Perforated



Patent No.: 8,132,767
8,434,725
Patent Pending

- CADDY® ROD LOCK technology allows for the quick creation, installation, and adjustment of multi-level trapeze assemblies
- Ready to use out of the box and eliminates the need for cutting and preparing sections of strut
- Easy "push-to-install" design allows installers to simply push the threaded rod through the mounting hole, instantly holding it in position
- Integrated adjustment nut enables fine tuning the system height up or down
- Lock nut can be finger tightened, locking the rod in place
- Works with all accessories that fit standard A or C type strut channels

Material: Steel
Finish: Pregalvanized, Electrogalvanized

Part Number	Description	
Strut Type: A		
CRLP237L14	A Strut, 3/8" Rod, 16"	2,668 lb
CRLP237L18	A Strut, 3/8" Rod, 20"	2,075 lb
CRLP237L22	A Strut, 3/8" Rod, 24"	1,698 lb
CRLP237L26	A Strut, 3/8" Rod, 28"	1,437 lb
CRLP237L38	A Strut, 3/8" Rod, 40"	983 lb
CRLP237L50	A Strut, 3/8" Rod, 52"	642 lb
Strut Type: C		
CRLP137L14	C Strut, 3/8" Rod, 16"	789 lb
CRLP137L18	C Strut, 3/8" Rod, 20"	613 lb
CRLP137L22	C Strut, 3/8" Rod, 24"	494 lb
CRLP137L26	C Strut, 3/8" Rod, 28"	354 lb
CRLP137L38	C Strut, 3/8" Rod, 40"	166 lb

Static loads are assumed to be uniformly distributed and include a hole factor of 0.92. The load applied to CADDY ROD LOCK Strut should include a factor of safety appropriate for the application in which the strut is being used. CADDY ROD LOCK Strut must be installed with the open side of the channel facing up. For in-door applications only.



50#/Cpc

Allowable Load = 800#
when used with
FS-7025-1/2"
or Larger

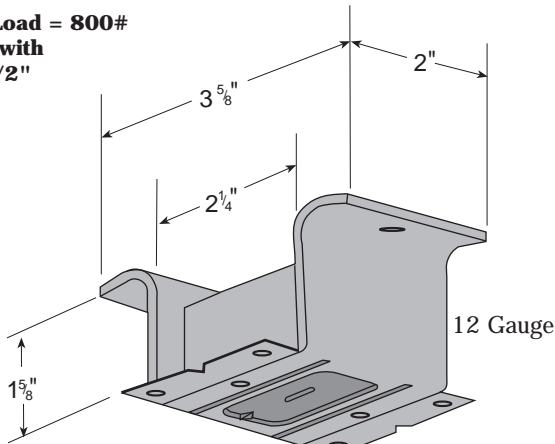

FS-7000
SPOT CONCRETE INSERT

Cat. No.	Tapped Size	#/Cpc
FS-7025-1/4"	1/4" -20	11#
FS-7025-3/8"	3/8" -16	15#
FS-7025-1/2"	1/2" -13	19#
FS-7025-5/8"	5/8" -11	18#
FS-7025-3/4"	3/4" -10	17#
FS-7025-7/8"	7/8" -9	15#

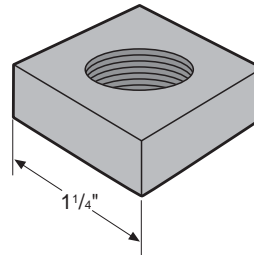

FS-7025 Series
INSERT SQUARE NUT

P/N	Allowable Load
FS-7350	800#
FS-7351	1000#
FS-7352	1200#
FS-7353	2000#
FS-7354/70	2000#/FT

FS-7370 Series

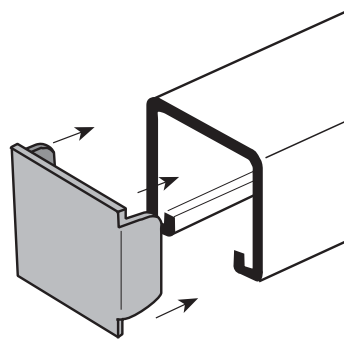
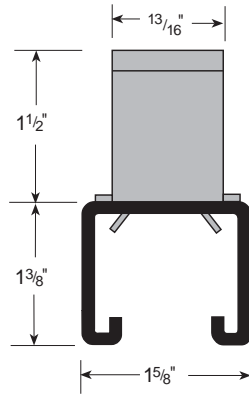

FS-5933

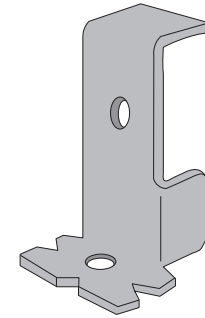

FS-5953

Cat. No.	Insert Length	End Cap Furnished	Weight Cpcs
FS-7350	4"	FS-5953	100#
FS-7351	6"	FS-5953	130#
FS-7352	8"	FS-5953	160#
FS-7353	12"	FS-5953	220#
FS-7354	16"	FS-5933	250#
FS-7355	20"	FS-5933	310#
FS-7356	24"	FS-5933	370#
FS-7357	32"	FS-5933	490#
FS-7357A	36"	FS-5933	550#
FS-7358	40"	FS-5933	610#
FS-7359	4'	FS-5933	730#
FS-7360	5'	FS-5933	910#
FS-7361	6'	FS-5933	1090#
FS-7362	7'	FS-5933	1270#
FS-7363	8'	FS-5933	1450#
FS-7364	9'	FS-5933	1630#
FS-7365	10'	FS-5933	1810#
FS-7366	12'	FS-5933	2170#
FS-7367	14'	FS-5933	2530#
FS-7368	16'	FS-5933	2890#
FS-7369	18'	FS-5933	3250#
FS-7370	20'	FS-5933	3610#

1-5/8" x 1-3/8" x 12 ga

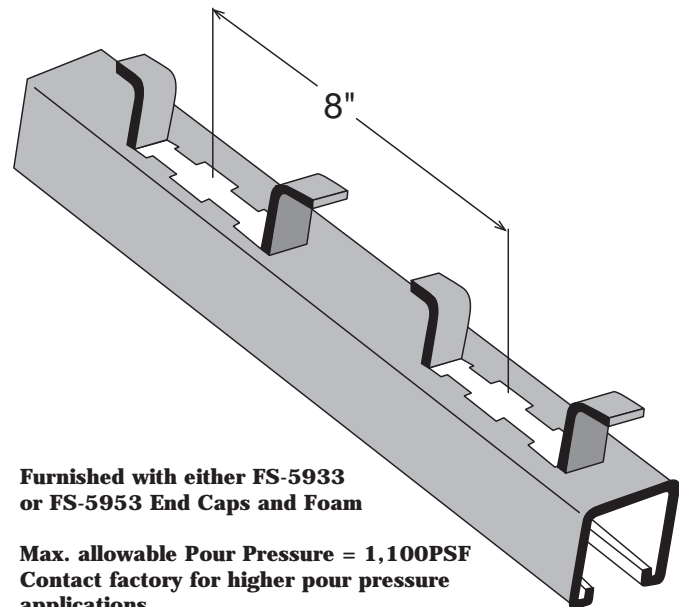

Furnished with either FS-5933
or FS-5953 End Caps and Foam

Max. allowable Pour Pressure = 1,100PSF
Contact factory for higher pour pressure
applications.

FS-7370 Series