

### Unit Overview

Unit Function	Tonnage	EER @ AHRI	IEER @ AHRI	System Power	Elevation
Natural Gas Heat	60 ton Air cooled	10.4 EER	16.5 EER	79.05 kW	0.00 ft
<b>Installed Weight</b>					
10672.1 lb					

### Unit Features

Capacity/Efficiency Option	eFlex- Variable Speed Compressor
Filters	High-Efficiency Throwaway Filters
Agency Approval	cULus



### Unit Electrical

Voltage/Phase/Frequency	200/60/3
Unit Mounted Power Connection / SCCR Rating	Unit disconnect switch (nonfused)
Unit Mounted Power Connection	Factory-Power 15A GFI convenience outlet

Condenser Fans FLA	24.60 A
Supply Fan FLA	82.20 A
Supply Fan Motor Count	1
Other FLA	5.00 A

Compressor 1 RLA	51.90 A
Compressor 1 Count	1.00 Each
Compressor 2 RLA	56.90 A
Compressor 2 Count	1.00 Each
Compressor 3 RLA	89.90 A
Compressor 3 Count	1.00 Each

#### Circuit 1

MCA	MOP	DSS	RDE
332.98 A	400.00 A	357.00 A	400.00 A

### Condensing Section

Capacity/Efficiency Option	eFlex- Variable Speed Compressor	Ambient Control	Standard ambient control
Refrigerant Type	R-410A refrigerant	Design Ambient Dry Bulb	95.00 F
Refrigerant Charge Circuit 1	42.0 lb	Outdoor Fan Type	Prop
Refrigerant Charge Circuit 2	42.5 lb	Outdoor Fan Drive	Direct

### Heating Section

Function	Natural Gas Heat	Heating EAT	56.00 F
Heat Capacity	2 Stage Low Gas Heat	Heating LAT	72.39 F
Input Heating Capacity	500.00 MBh	Heating DeltaT	16.39 F
Output Heating Capacity	400.00 MBh		
Output Heating Capacity w/ Fan	400.00 MBh		



### Cooling Coil (DX) Section

Evaporator Type		Cooling Performance	
Evaporator Type	Cu-Al	Leaving Coil Dry Bulb	54.19 F
Evaporator Face Area	43.00 sq ft	Leaving Coil Wet Bulb	53.15 F
Evaporator Face Velocity	523 ft/min	Leaving Unit Dry Bulb	56.94 F
<b>Inputs</b>		Leaving Unit Wet Bulb	54.27 F
		Gross Total Capacity	725.94 MBh
Design Airflow	22500 cfm	Gross Sensible Capacity	601.54 MBh
Entering Dry Bulb	78.00 F	Gross Latent Capacity	124.40 MBh
Entering Wet Bulb	64.00 F	Net Total Capacity	657.47 MBh
		Net Sensible Capacity	533.06 MBh
		Net Sensible Heat Ratio (%)	81.08 %

### Modulating Hot Gas Reheat (HGRH) & Hot Gas Bypass

Refrigeration Option	Mod HGRH without hot gas bypass	Reheat Mode Leaving Unit Temp	64.00 F
Entering DX Dry Bulb (in HGRH)	76.00 F	Leaving Unit Dew Point in HGRH	56.03 F
Entering DX Wet Bulb (in HGRH)	68.00 F	Reheat Mode Moisture Removal	39.51 gph
Ambient DB (in HGRH)	76.00 F	Reheat Mode Sensible Capacity	347.12 MBh
Ambient WB (in HGRH)	68.00 F	Reheat Mode Latent Capacity	354.69 MBh

### Supply Fan

Supply Fan Type		Performance	
Supply Fan Type	FC	Design Airflow	22500 cfm
Supply Fan Count	2.00 Each	Supply Duct Static Pressure	1.000 in H2O
Supply Fan Motor HP	30 hp FC	Total Supply Static Pressure	3.217 in H2O
Supply Motor Count	1	Total Supply BHP	25.03 bhp
Supply Fan Motor Drive	900 rpm	Operating Speed (RPM)	862 rpm
System Control	VAV (Single Zone) - w/ VFD w/o Bypass	Supply Fan Efficiency	45.50 %
Isolator Option	2.00" [51mm] Spring isolators	Supply Fan Motor Heat	68.48 MBh

### Outside Air & Relief Sections

Outside Air Section		Relief Section	
Outside Air Option	0-100% Economizer	Fan Type	Barometric
Outside Air Control	Econ Control w/comparative enthalpy	Return Duct Static Pressure	0.500 in H2O
		Fan Option	Barometric relief
		Isolator Option	2.00" [51mm] Spring isolators

### Acoustics

	63	125	250	500	1K	2K	4K	8K
Ducted Discharge (Supply)	93 dB	91 dB	87 dB	86 dB	82 dB	77 dB	71 dB	66 dB
Ducted Inlet (Return)	89 dB	80 dB	75 dB	72 dB	68 dB	64 dB	60 dB	54 dB
Outdoor Noise	101 dB	94 dB	91 dB	90 dB	88 dB	83 dB	81 dB	78 dB

Acoustic Notes	
Outdoor includes all compressors and condenser fans running with any Exhaust or Return fans running at full exhaust	Outdoor Noise data conform to AHRI 270/370
	Octave Band Sound Power in dB re 1 pW
Supply and Return data taken in accordance with AHRI Standard 260-2012	



### Weights

<b>Total Installed Weight</b>	10672.1 lb	<b>Installed Point Load Weight 1</b>	715.8 lb
<b>Center of Gravity - X</b>	18.09 ft	<b>Installed Point Load Weight 2</b>	705.3 lb
<b>Center of Gravity - Y</b>	4.81 ft	<b>Installed Point Load Weight 3</b>	904.6 lb
<b>Installed Point Load X1 Location</b>	4.000 in	<b>Installed Point Load Weight 4</b>	894.1 lb
<b>Installed Point Load X2 Location</b>	101.000 in	<b>Installed Point Load Weight 5</b>	1072.1 lb
<b>Installed Point Load X3 Location</b>	187.000 in	<b>Installed Point Load Weight 6</b>	1061.6 lb
<b>Installed Point Load X4 Location</b>	274.000 in	<b>Installed Point Load Weight 7</b>	1241.5 lb
<b>Installed Point Load X5 Location</b>	370.000 in	<b>Installed Point Load Weight 8</b>	1230.9 lb
<b>Installed Point Load Y1 Location</b>	4.000 in	<b>Installed Point Load Weight 9</b>	1428.4 lb
<b>Installed Point Load Y2 Location</b>	112.000 in	<b>Installed Point Load Weight 10</b>	1417.9 lb

### Controls & Service Options

Controls		Service	
<b>Communication Protocol</b>	BACnet communication interface module	<b>Cabinet Options</b>	IRU w/ galv - w/ access doors
		<b>Service Options</b>	Grease lines

### Accessories/Misc.

<b>Refrigeration Option</b>	Mod HGRH without hot gas bypass
-----------------------------	---------------------------------

### AHRI Certification

Packaged Rooftop units cooling, heating capacities and efficiencies are rated within the scope of the Air-Conditioning, Heating & Refrigeration Institute (AHRI) Certification Program and display the AHRI Certified® mark as a visual confirmation of conformance to the certification sections of AHRI Standard 340-360 (I-P) and ANSI Z21.47 and 10 CFR Part 431 pertaining to Commercial Warm Air Furnaces. Certified units may be found in the AHRI directory at [www.ahridirectory.org](http://www.ahridirectory.org)

- NOTES:
1. VERIFY WEIGHT, CONNECTION, AND ALL DIMENSION WITH INSTALLER DOCUMENTS BEFORE INSTALLATION.
  2. LOW AMBIENT DAMPER ONLY COMES WITH SELECTED UNIT.
  3. OVERALL UNIT WIDTH INCREASES 5/8" BEYOND LIFTING LUG WITH ULTRA LOW LEAK POWER EXHAUST DAMPERS.
  4. RETURN AIR OPENING CONFIGURATION FOR USES WITH NO AIR OPTION, BAROMETRIC RELIEF, AND EXHAUST FAN.
  5. IF FIELD CONVERTING SUPPLY & RETURN OPENING(S) TO HORIZONTAL OR VERTICAL AIRFLOW, FACTORY MUST VERIFY IF UNIT OPTIONS WILL ALLOW IT. FACTORY INSTALLATION IS ALWAYS RECOMMENDED.

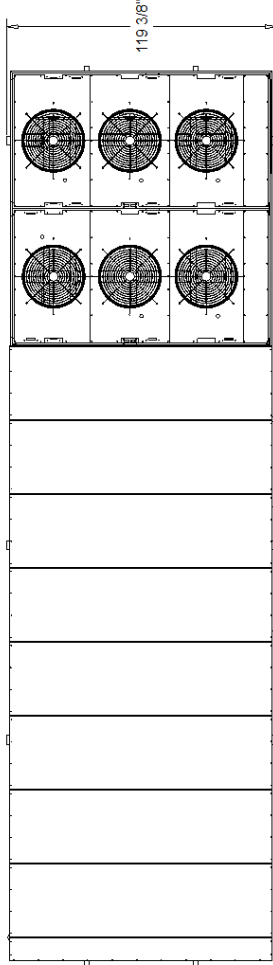

60/70/75 TON PLAN VIEW

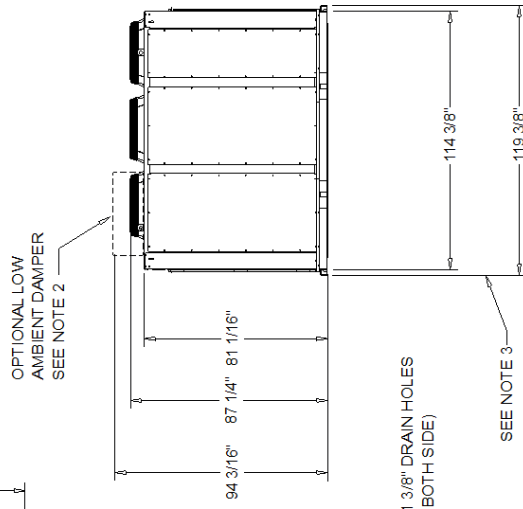

OPTIONAL LOW AMBIENT DAMPER SEE NOTE 2

SEE NOTE 3

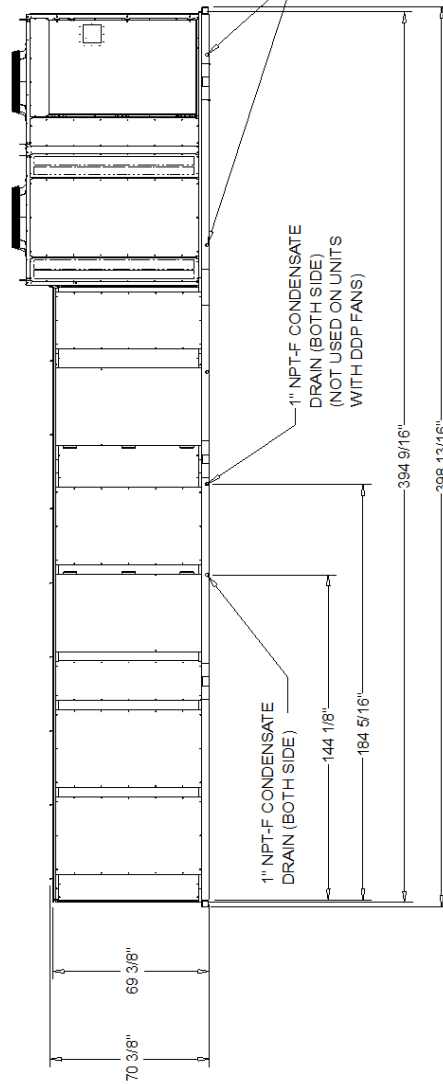

1" NPT-F CONDENSATE DRAIN (BOTH SIDE)

1" NPT-F CONDENSATE DRAIN (BOTH SIDE) (NOT USED ON UNITS WITH DDP FANS)

1 3/8" DRAIN HOLES (BOTH SIDE)

60/70/75 TON LEFT SIDE VIEW

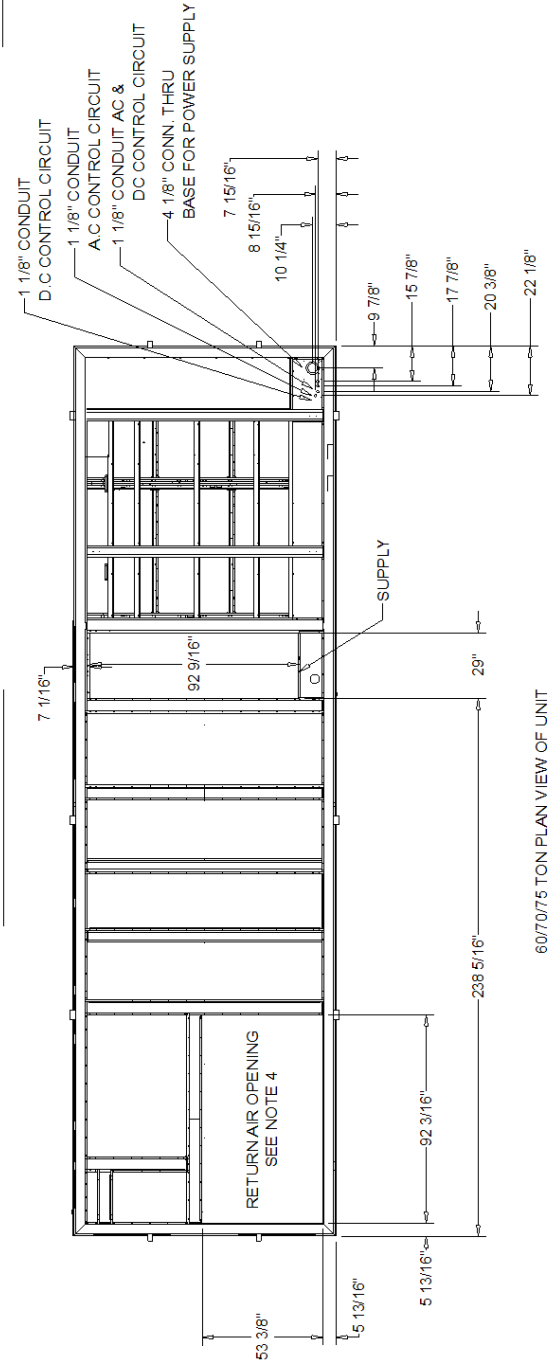

RETURN AIR OPENING SEE NOTE 4

SUPPLY

60/70/75 TON FRONT VIEW

60/70/75 TON PLAN VIEW OF UNIT

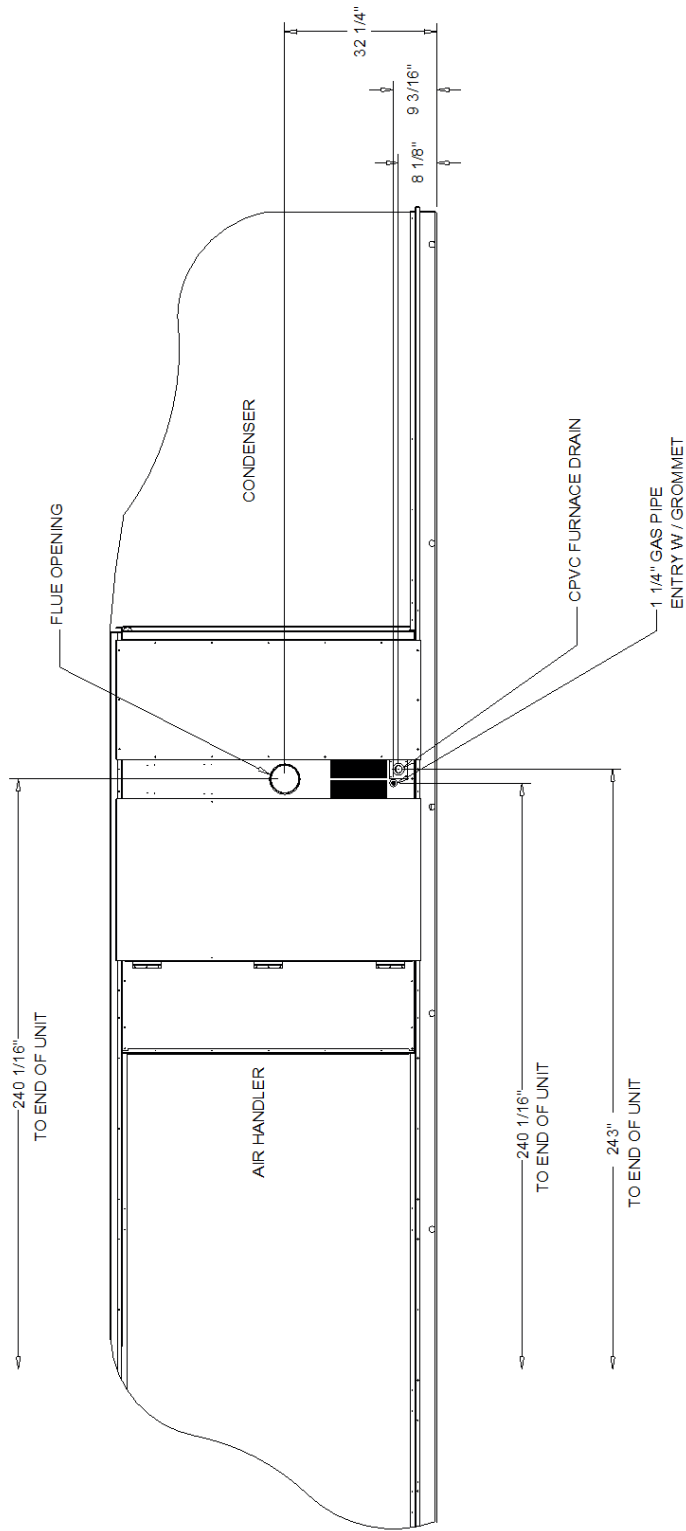

60 - 75 500MBH TON GAS HEAT  
 LEFT SIDE OF UNIT

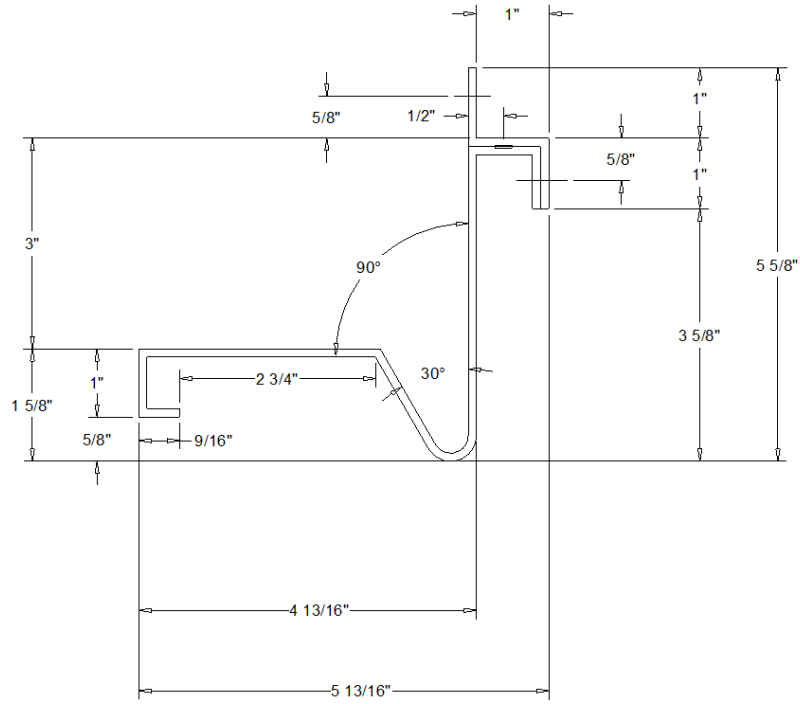

TYPICAL PEDESTAL AND BASE  
 DIMENSION DRAWING

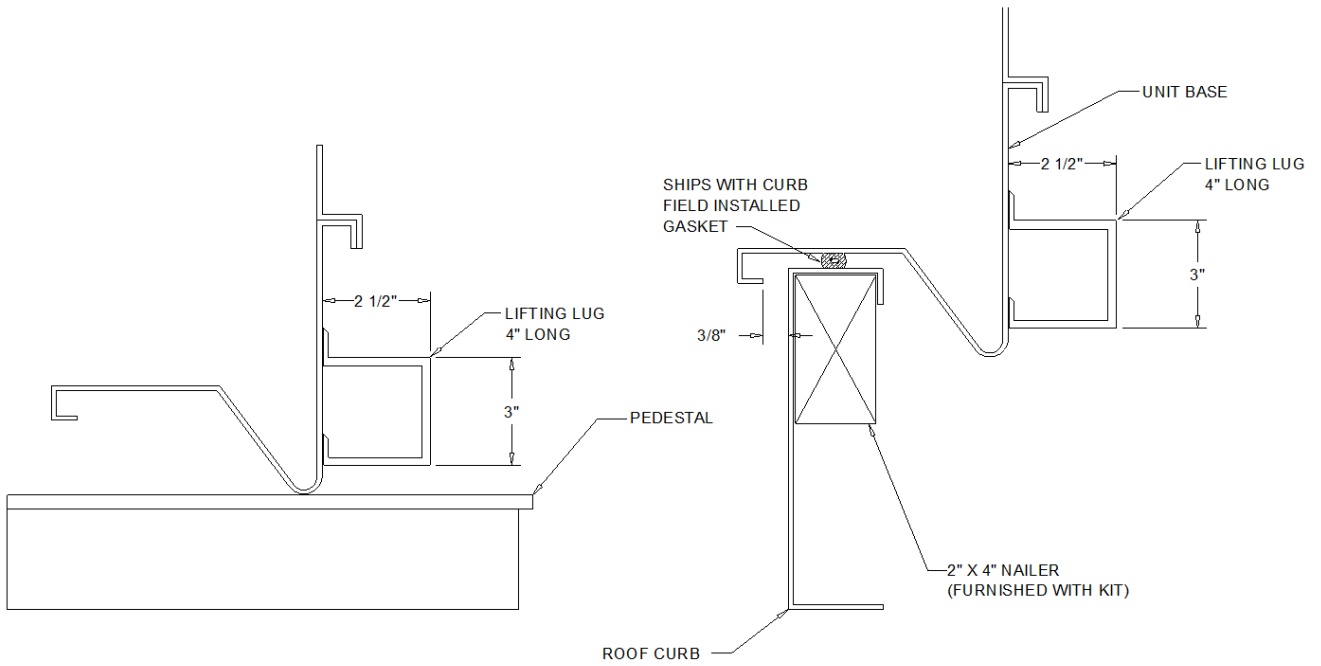

TYPICAL PEDESTAL AND BASE PAN DETAIL  
 DETAIL

TYPICAL ROOF CURB AND BASE PAN DETAIL  
 DETAIL



### ELECTRICAL / GENERAL DATA

<b>TONS</b> Model (Tonnage): SFHFL60 (60Ton) Unit Operating Voltage Range: 180-220 Unit Primary Voltage: 200 Unit Hertz: 60 Unit Phase: 3  EER: 10.4 EER IEER: 16.5 EER	<b>GAS HEATING - PERFORMANCE</b> Heating Input: 500 Heating Output: 400 Capacity Steps: 2  <b>HEATING - GENERAL DATA</b> Gas inlet pressure: (in w. c.) 1 1/4" Gas Pipe Connection Size: 7" wc - 14" wc
<b>COMPRESSOR</b> Compressor 1 Count: 1.00 Each Compressor 1 RLA: 51.90 A Compressor 2 Count: 1.00 Each Compressor 2 RLA: 56.90 A Compressor 3 Count: 1.00 Each Compressor 3 RLA: 89.90 A	<b>ELECTRIC HEATER</b> Electric Heater Kw: Electric Heater Full Load Amps:
<b>SUPPLY FAN MOTOR</b> Number of Fans: 2.00 Each Number of Motors: 1 Total Horsepower: Supply Fan Hp: 30 hp FC Supply Fan Motor Full Load Amps: 82.20 A Supply Fan Efficiency: 45.50 %	<b>EXHAUST / RETURN FAN MOTOR SECTION</b> Number: Value not available Horsepower (Each): Barometric relief Exhaust/Return Fan Motor FLA: Value not available
<b>CONDENSER FAN MOTOR</b> Number: 6 Horsepower (each): 1.0 Condenser Fan Motor Full Load Amps (Total): 24.6	<b>FILTERS - TYPE</b> Type: Fumished: YES Number: 35 Recommended Size: 16" x20" x2"
<b>EVAPORATIVE CONDENSER (7)</b> Pump Horsepower: N/A Pump Full Load Amps: N/A Sump Heater Full Load Amps: N/A Sump Heater kW: N/A	<b>PREFILTERS</b> Fumished: Number: Recommended Size:
<b>REFRIGERANT TYPE (6)</b> Charge Type: R-410A Factory Charge (Circuit #1): 42.0 lb Factory Charge (Circuit #2): 42.5 lb	<b>FINAL FILTERS - TYPE</b> Type: Fumished: Number: Recommended Size:  <b>PREFILTERS</b> Fumished: Number: Recommended Size:

Notes:

- LOAD 1=Current of the largest motor (compressor or fan motor); LOAD 2=Sum of the currents of all remaining motors; LOAD 3 =Current of electric heaters  
 LOAD 4 =Control Power Transformer (20-40 and 24-48 ton units add 3 FL amps for wire sizing formula, 50-75 and 59 - 89 ton units add 6 FL amps)
- For Electric Heat MCA, MOP, RDE values, calculate for both cooling and heating modes. (When determining LOADS, the compressors do not operate when the unit is in heating mode) (On 70-89 ton single source units, heating Load 4 = 12 amps on 200,230 volt units and 9 amps on 460,575 volt units)
- If selected Max Over Cur is less than the Min Clr Amp, then select the lowest maximum fuse size which is equal to or larger than the Min Cir Amp, provided the selected fuse size does not exceed 800 amps.
- If the selected Recommended Dual Element fuse size is greater than the selected Max Over Cur Protection value, then select the Recommended Dual Element fuse size value to equal the Max Over Protection value.
- Compressor KW at AHRI rating conditions of 80/67 -95
- Refrigerant charge is an approx. value. For a more precise value, see unit nameplate and service instructions.
- Sump Heater is an optional feature.
- Total Horsepower is the combined Horsepower for the Supply Fan Motors.

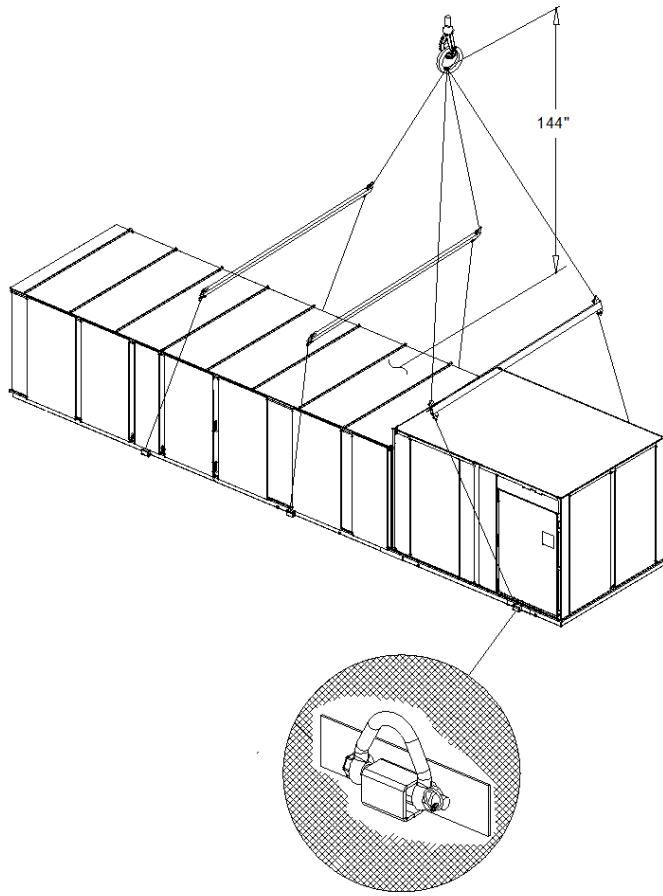

**Note:**  
 When 2 or more units are to be placed side by side, the distance between the units should be increased to 150% of the recommended single unit clearance. The units should also be staggered to reduce span deflection & assure proper diffusion of exhaust air.

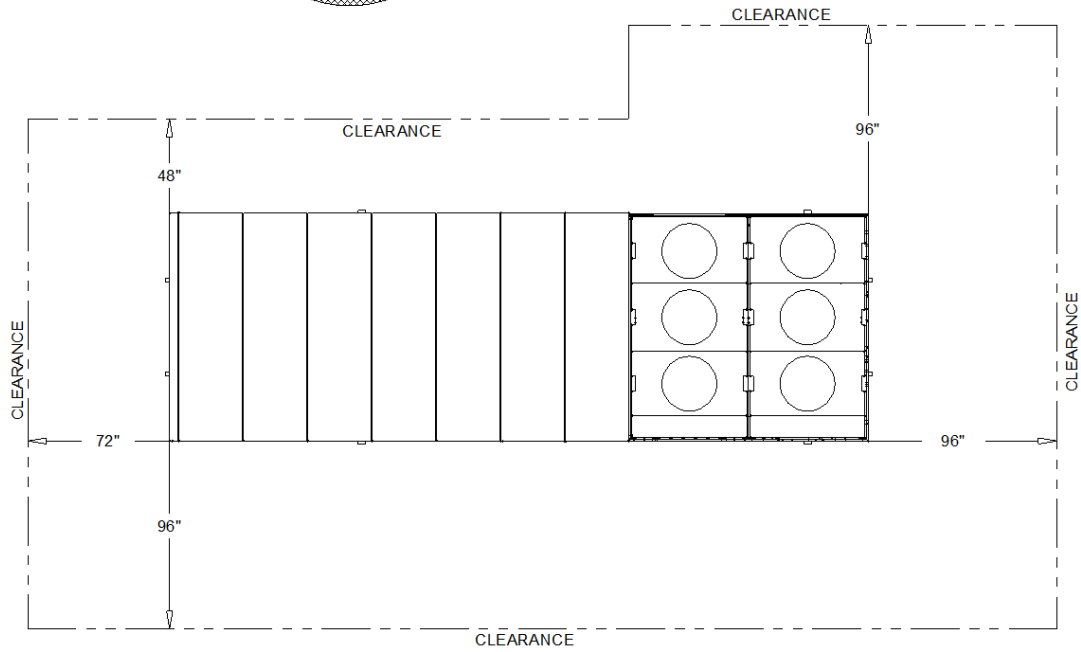

**RIGGING AND CLEARANCE**  
 AIR COOLED DRAWING

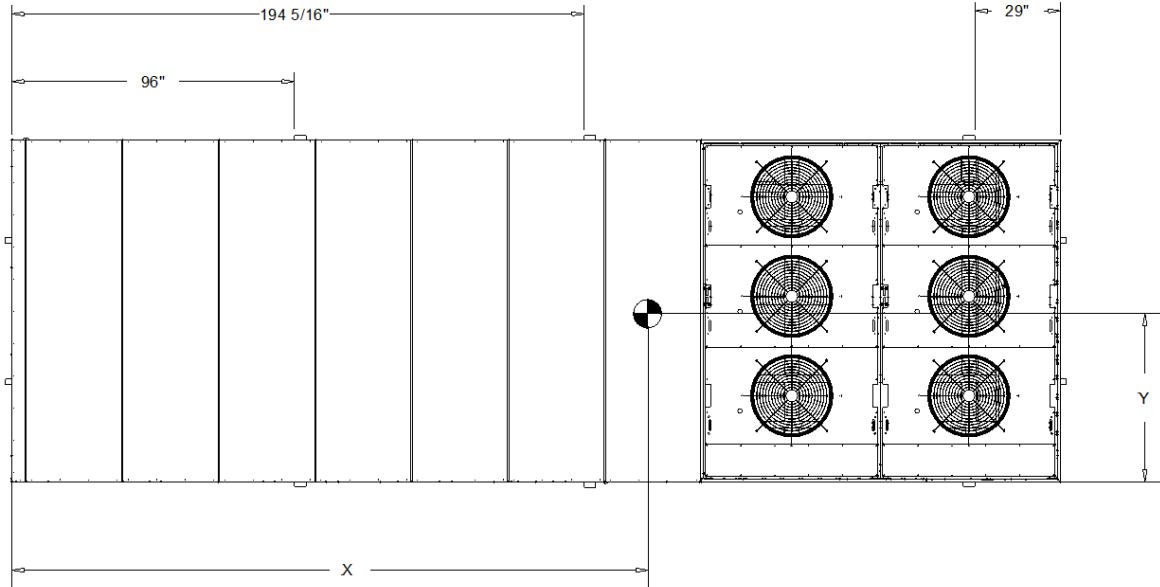

Center of Gravity X:	18.09 ft	Point load X location 1:	4.000 in
Center of Gravity Y:	4.81 ft	Point load X location 2:	101.000 in
Point Load 1:	715.8 lb	Point load X location 3:	187.000 in
Point Load 2:	705.3 lb	Point load X location 4:	274.000 in
Point Load 3:	904.6 lb	Point load X location 5:	370.000 in
Point Load 4:	894.1 lb	Point load X location 6:	N/A
Point Load 5:	1,072.1 lb	Point load X location 7:	N/A
Point Load 6:	1,061.6 lb	Point load X location 8:	N/A
Point Load 7:	1,241.5 lb	Point load X location 9:	N/A
Point Load 8:	1,230.9 lb	Point load X location 10:	N/A
Point Load 9:	1,428.4 lb	Point load Y location 1:	4.000 in
Point Load 10:	1,417.9 lb	Point load Y location 2:	112.000 in
Total Weight:	10,672.1 lb		

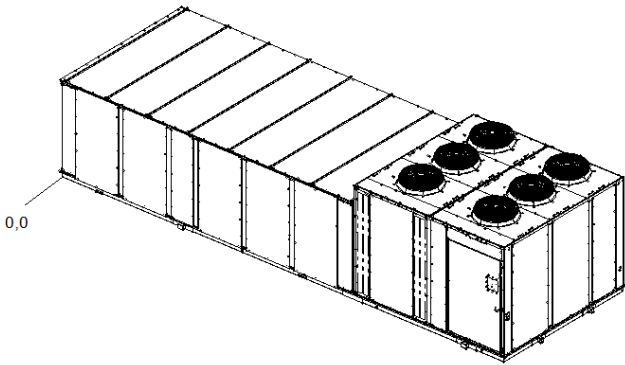

- Notes:
1. The actual weight is stamped on the unit nameplate.
  2. The weight shown represents the typical unit operating weight for the configuration selected. Estimated at +/- 10% of the nameplate weight.
  3. Design Special weights are not displayed. Any weight added through COD (Custom Order Design) will not be accounted in the +/- 10% estimate.
  4. When 2 or more units are to be placed side by side, the distance between the units should be increased to 150% of the recommended single unit clearance. The units should also be staggered to reduce span deflection & assure proper diffusion of exhaust air.

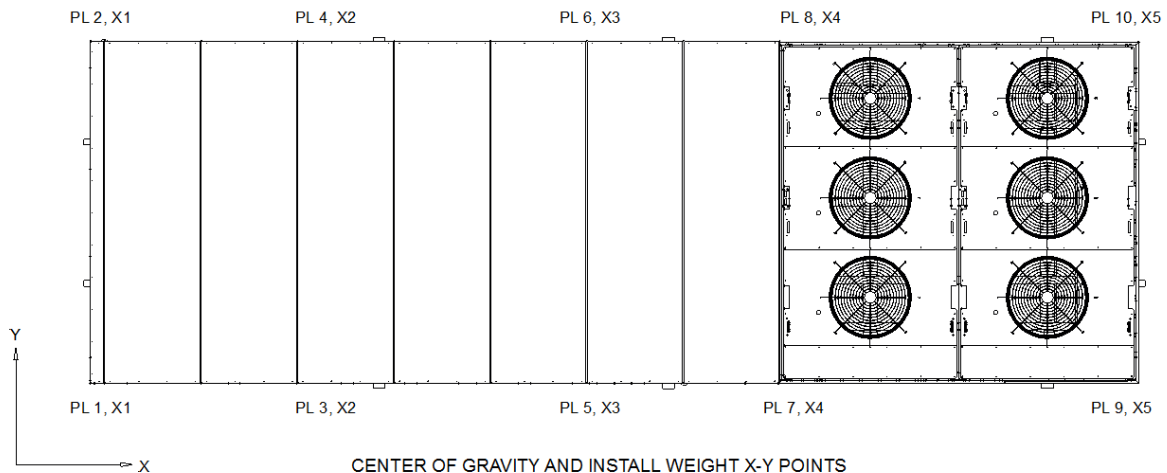

CENTER OF GRAVITY AND INSTALL WEIGHT X-Y POINTS  
 AIR COOLED DRAWING

**⚠ WARNING**

**HAZARDOUS VOLTAGE!**

DISCONNECT ALL ELECTRIC POWER INCLUDING REMOTE DISCONNECTS AND FOLLOW LOCK OUT AND TAG PROCEDURES BEFORE SERVICING. INSURE THAT ALL MOTOR CAPACITORS HAVE DISCHARGED STORED VOLTAGE. UNITS WITH VARIABLE SPEED DRIVE, REFER TO DRIVE INSTRUCTIONS FOR CAPACITOR DISCHARGE.

FAILURE TO DO THE ABOVE BEFORE SERVICING COULD RESULT IN DEATH OR SERIOUS INJURY.

**⚠ AVERTISSEMENT**

**TENSION DANGEREUSE!**

COUPER TOUTES LES TENSIONS ET OUVRIER LES SECTIONNEURS A DISTANCE, PUIS SUIVRE LES PROCEDURES DE VERROUILLAGE ET DES ETIQUETTES AVANT TOUTE INTERVENTION. VERIFIER QUE TOUTS LES CONDENSATEURS DES MOTEURS SONT DECHARGES. DANS LE CAS D'UNITES COMPORTANT DES ENTRAINEMENTS A VITESSE VARIABLE, SE REPORTER AUX INSTRUCTIONS DE L'ENTRAINEMENT POUR DECHARGER LES CONDENSATEURS.

NE PAS RESPECTER CES MESURES DE PRECAUTION PEUT ENTRAINDER DES BLESSURES GRAVES POUVANT ETRE MORTELLES.

**⚠ ADVERTENCIA**

**¡VOLTAJE PELIGROSO!**

DESCONECTE TODA LA ENERGIA ELECTRICA, INCLUSO LAS DESCONEXIONES REMOTAS Y SIGA LOS PROCEDIMIENTOS DE CIERRE Y ETIQUETADO ANTES DE PROCEDER AL SERVICIO. ASEGURESE DE QUE TODOS LOS CAPACITORES DEL MOTOR HAYAN DESCARGADO EL VOLTAJE ALMACENADO. PARA LAS UNIDADES CON EJE DE DIRECCION DE VELOCIDAD VARIABLE, CONSULTE LAS INSTRUCCIONES PARA LA DESCARGA DEL CONDENSADOR.

EL NO REALIZAR LO ANTERIORMENTE INDICADO, PODRIA OCASIONAR LA MUERTE O SERIAS LESIONES PERSONALES.

**CAUTION**

USE COPPER CONDUCTORS ONLY!

UNIT TERMINALS ARE NOT DESIGNED TO ACCEPT OTHER TYPES OF CONDUCTORS.

FAILURE TO DO SO MAY CAUSE DAMAGE TO THE EQUIPMENT.

**ATTENTION**

N'UTILISER QUE DES CONDUCTEURS EN CUIVRE!

LES BORNES DE L'UNITE NE SONT PAS CONCUES POUR RECEVOIR D'AUTRES TYPES DE CONDUCTEURS.

L'UTILISATION DE TOUT AUTRE CONDUCTEUR PEUT ENDOMMAGER L'EQUIPEMENT.

**PRECAUCION**

UTILICE UNICAMENTE CONDUCTORES DE COBRE!

LAS TERMINALES DE LA UNIDAD NO ESTAN DISENADAS PARA ACEPTAR OTROS TIPOS DE CONDUCTORES.

SI NO LO HACE, PUEDE OCASIONAR DANO AL EQUIPO.

**IMPORTANT!**

DO NOT ENERGIZE UNIT UNTIL CHECK-OUT AND START-UP PROCEDURE HAS BEEN COMPLETED.

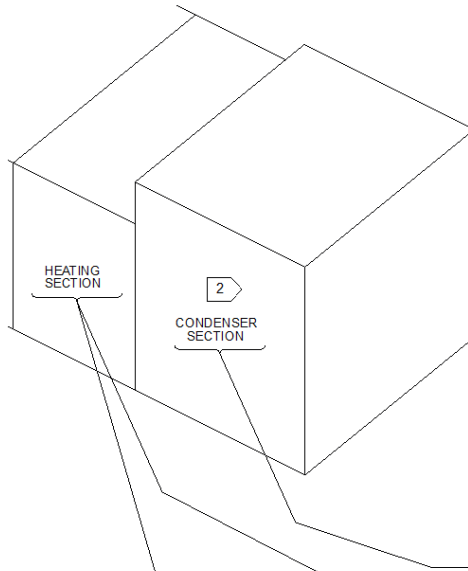

DEVICE PREFIX LOCATION CODE	
AREA	LOCATION
1	INSIDE UNIT CONTROL BOX
2	CONDENSER SECTION
3	AIR HANDLER SECTION
4	HEATING SECTION
5	EXTERNAL FIELD MOUNTED DEVICE

Note:  
All wiring and components shown dashed to be supplied and installed by the customer in accordance with local electrical codes.

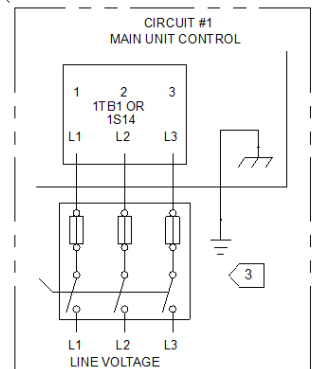
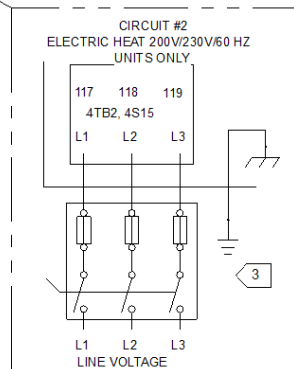
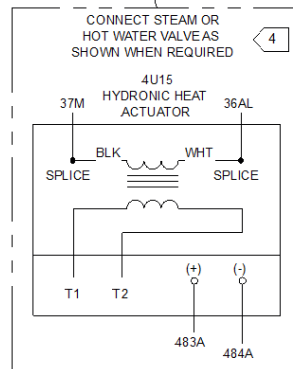

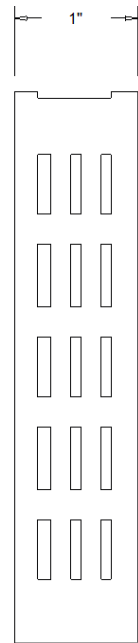
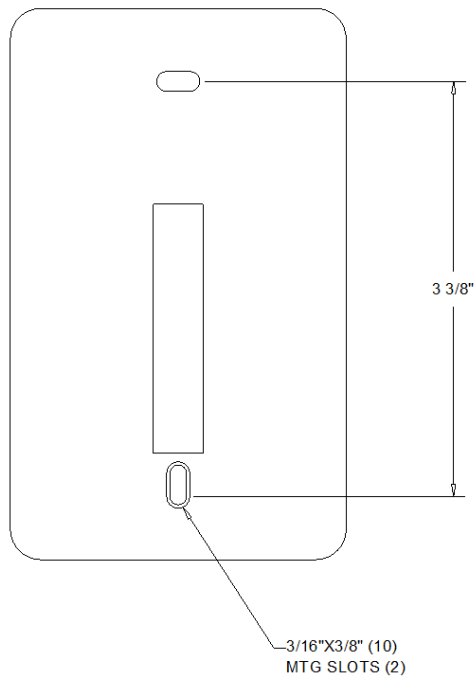
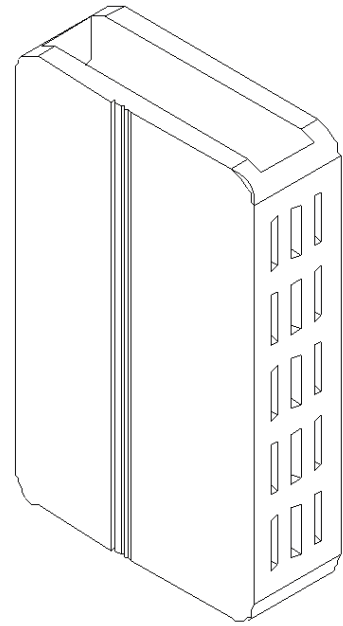
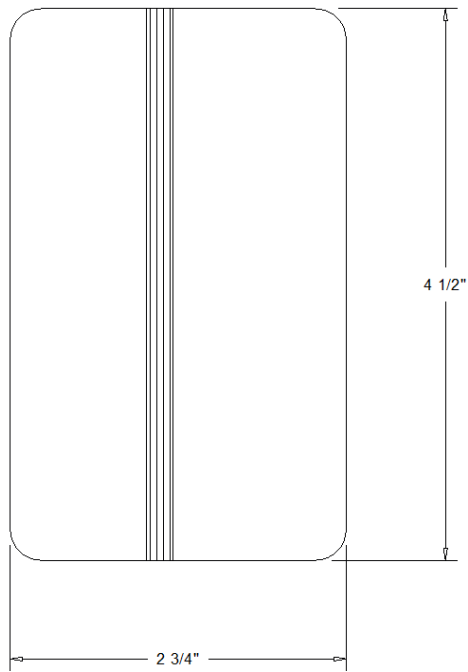

BAYSENS036 - HUMIDITY WALL MOUNTED SENSOR

## General - R410A

Units shall be specifically designed for outdoor rooftop installation on a roof curb and be completely factory assembled and tested, piped, internally wired, fully charged with R-410A compressor oil and shipped in one piece. Units shall be available for direct expansion cooling only, or direct expansion cooling with natural gas, electric, hot water or steam heating. Filters, outside air system, exhaust air system, optional non-fused disconnect switches and all operating and safety controls shall be furnished factory installed. All units shall be cULus approved and factory run tested. Cooling capacity shall be rated in accordance with AHRI Standard 360. All units shall have decals and tags to aid in service and indicate caution areas. Electrical diagrams shall be printed on long life water resistant material and shall ship attached to control panel doors.

## Casing

Exterior panels shall be zinc coated galvanized steel, phosphatized and painted with a slate grey air-dry finish durable enough to withstand a minimum of 672 hours consecutive salt spray application in accordance with standard ASTM B117. Screws shall be coated with zinc-plus-zinc chromate. Heavy gauge steel hinged access panels with tiebacks to secure door in open position shall provide access to filters and heating sections. Refrigeration components, supply air fan and compressor shall be accessible through removable panels as standard. Unit control panel, filter section, and gas heating section shall be accessible through hinged access panels as standard. Optional Double Wall Construction hinged access doors shall provide access to filters, return/exhaust air, heating and supply fan section. All access doors and panels shall have neoprene gaskets. Interior surfaces or exterior casing members shall have 1/2" fiberglass insulation. Unit base shall be watertight with heavy gauge formed load bearing members, formed recess and curb overhang. Unit lifting lugs shall accept chains or cables for rigging. Lifting lugs shall also serve as unit tiedown points.

## IntelliPak Replacement Unit (IRU)

The IntelliPak replacement solution shall include a condenser base pan, strengthening of the condenser section with welded reinforcement of condenser base rail, as well as welded integral supports to the condenser base. This additional strength shall allow the reuse of the existing pedestal as well as any Trane full perimeter curb and reduce installation risk and labor. Also optional with stainless steel.

## Hinged Access Doors

Hinged access doors shall provide easy access to supply fan, filters, exhaust/return fan, and heating section. These access doors shall feature double wall construction with dual density insulation sandwiched between heavy gauge galvanized steel panels for strength and durability.

## Air-Cooled Condenser Coil - R410A

Condenser coils shall have all Aluminum Microchannel coils. All coils shall be leak tested at the factory to ensure pressure integrity. The condenser coil is pressure tested to 650psig Subcooling circuit(s) shall be provided as standard.

## Condenser Fans and Motors

All condenser fans shall be vertical discharge, direct drive fans, statically balanced, with aluminum blades and zinc plated steel hubs. Condenser fan motors shall be three-phase motors with permanently lubricated ball bearings, built-in current and thermal overload protection and weathertight slingers over motor bearings.

## Evaporator Coil - R410A

Internally enhanced copper tubing of 3/8" or 1/2" O.D. shall be mechanically bonded to heavy duty aluminum fins of configured design. All coils shall be equipped with thermal expansion valves and factory pressure and leak tested.

## Compressors - R410A

The Trane Scroll compressor shall be industrial grade, direct drive 3600 RPM maximum speed scroll type. The motor shall be suction gas-cooled hermetic design. Compressor shall have centrifugal oil pump with dirt separator, oil sight glass, and oil charging valve. Compressor shall also be provided with thermostatic motor winding temperature control to protect against excessive motor temperatures resulting from over-/under-voltage or loss of charge, high and low pressure cutouts, and reset relay.

## Variable Speed Compressors

The Trane eFlex variable speed compressor shall be capable of speed modulation from 1500 rpm to a maximum of 6000 rpm. This allows variable speed units to modulate capacities to 15% of full load or below. The compressor motor shall be a permanent magnet type for all but 575V units. Each compressor shall have a crankcase heater installed and properly sized to minimize the amount of liquid refrigerant present in the oil sump during off cycles. Each variable speed compressor is matched with a specially designed variable frequency drive which modulates the speed of the compressor motor and provides several compressor protection functions.

## Modulating Hot Gas Reheat

A unit with the hot gas reheat option shall consist of the following refrigerant components on one circuit: a hot gas reheat coil, a cooling modulating valve, a reheat modulating valve, a reheat check valve, a reheat pump out solenoid, and additional interconnected tubing.

## Phase Monitor

Shall protect 3-phase equipment from phase loss, phase reversal, and low voltage. Any fault condition shall produce a Failure Indicator LED, and send the unit into an emergency stop condition. cULus approved. (Standard on 20-75T units)

## Gas-fired heating option, Staged

All gas-fired units shall be completely assembled and have a wired gas fired heating system integral within unit. Units shall be cULus or CSA approved specifically for outdoor applications downstream from refrigerant cooling coils. All gas piping shall be threaded connection with a pipe cap provided. Gas supply connection shall be provided through the side or bottom of unit. All units shall be fire tested prior to shipment. Heat Exchanger shall be tubular two pass design with stainless steel primary and secondary surfaces. Free floating design shall eliminate expansion and contraction stresses and noises. Gasketed cleanout plate shall be provided for cleaning of tubes/turbulators. Heat exchanger shall be factory pressure and leak tested. Burner shall be a stainless steel industrial type with an air proving switch to prevent burner operation if the burner is open for maintenance or inspection. Ceramic cone shall be provided to shape the flame to prevent impingement on sides of heat exchanger drum. Burner assembly shall house ignition and monitoring electrode. Combustion Blower shall be centrifugal type fan to provide air required for combustion. Fan motor shall have built-in thermal overload protection. Gas Safety Controls shall include electronic flame safety controls to require proving of combustion air prior to ignition sequence which shall include a 60 second pre-purge cycle. Direct spark ignition shall be provided on 235 and 350 MBh heat exchangers and pilot ignition shall be provided on 500 and 850 MBh heat exchanger units. Sixty second delay shall be provided between first and second stage gas valve operation on two-stage heaters. Continuous electronic flame supervision shall be provided as standard.

## Supply Fan

Supply fan motors shall be either open drip-proof or enclosed fan cooled. All supply fans shall be dynamically balanced in factory. Supply fan shall be test run in unit and shall reach rated rpm. All 60 Hz supply fan motors meet the Energy Independence Security Act of 2007 (EISA). All 50 Hz supply fan motors meet the U.S. Energy Policy Act of 1992 (EPACT).

## Forward Curved Supply Fan

Supply fans shall have two double-inlet, forward-curved fans mounted on a common shaft with fixed sheave drive. Fans shall be factory-tested to reach rated rpm before the fan shaft passes through first critical speed. Fan shaft shall be mounted on two grease lubricated ball bearings designed for 200,000 hours average life. Optional extended grease lines shall allow greasing of bearings from unit filter section. Fan motor and fan assembly shall be mounted on common base to allow consistent belt tension with no relative motion between fan and motor shafts. Entire assembly shall be completely isolated from unit and fan board by double deflection rubber-in-shear isolators, or by optional 2" deflection spring isolation.



### **Single Zone Variable Air Volume**

Single zone VAV option shall be provided with all necessary controls to operate a rooftop unit based on maintaining two temperature setpoints; the discharge air and zone. Option shall include factory-installed variable frequency drive (VFD) to provide supply fan motor speed modulation. During One Zone VAV cooling, the unit will maintain zone cooling setpoint by modulating the supply fan speed more or less to meet zone load demand, and the unit will maintain discharge temperature to the discharge cooling setpoint by modulating economizer if available and staging dx cooling.

## Variable Frequency Drive

Unit shall include factory-installed and tested variable frequency drive[s] (VFD) to provide motor speed modulation. The VFD shall receive a 0-10VDC speed signal from the unit controller. The drive will respond to the signal by accelerating or decelerating to maintain the controlling set point (duct static, space pressure, etc). VFD shall also include the following features:

1. Designed, constructed, and tested in accordance with NEMA ICS, NFPA, and IEC standards and housed in a plastic IP20 enclosure.
2. DC link reactors on both the positive and negative rails of the DC bus equal to 3% impedance to minimize power line harmonics.
3. Full rated output current continuously - 110% of rated current for 60 seconds and 160% of rated current for up to 0.5 second while starting.
4. Isolation between the Drive's power circuitry and control circuitry to ensure operator safety and to protect connected electronic control equipment from damage caused by voltage spikes, current surges, and ground loop currents.
5. Audible noise reduction through automatic adjustment of the carrier frequency and frequency avoidance.
6. Rated at 40C with a standard operating range of -10 to 50C (14 to 124F) ambient temperatures and 0 to 95% relative humidity
7. Self-diagnostics and motor protections such as: cULus listed overload, phase loss, and internal thermal overload.
8. Off/Stop and Auto/Start selector switches to start and stop the AC Drive and determine the speed reference.
  - a. On units with bypass, an AC Drive/Off/Bypass hand selector switch shall be provided in the unit control box
  - b. In DRIVE mode speed reference shall be provided by a 0-10 VDC analog input
9. A keypad interface which shall be programmable by language and feature multiple lines for easy reading.
10. Controlled and/or accessible points such as AC Drive Start/Stop, speed reference, and fault diagnostics.
11. Meter points such as motor power in HP, motor power in kW, motor kW-hr, motor current, motor voltage, hours run, DC link voltage, thermal load on motor, Thermal load on AC Drive and Heatsink temperature.
12. Troubleshooting features such as:
  - a. AC Drive memory storage of the last 10 faults and related operational data
  - b. Four simultaneous displays: frequency or speed, run time, output amps and output power
  - c. Keypad which shall display: Reference Signal Value, Output Frequency in Hz or percent, Output Amps, Motor HP, Motor kW, kW
13. Coated circuit boards for protection against corrosive environments
14. Field readable BACnet points to allow for communication of status, setpoints and diagnostics to the BAS.

## Extended Grease Lines

Lines shall be provided to allow greasing of supply and exhaust/return fan bearings through the filter access door.



### **Two-inch Spring Isolators**

Supply and Exhaust/Return fan (if applicable) assemblies shall be isolated with two-inch nominal deflection to reduce transmission of vibrations

### **Barometric relief**

Gravity dampers shall open to relieve positive pressure in the return air section of the rooftop. Barometric relief dampers shall relieve building over pressurization, when that over pressurization is great enough to overcome the return duct pressure drops.

### **0-100 percent modulating economizer**

Operated through the primary temperature controls to automatically utilize OA for "free" cooling. Automatically modulated return and OA dampers shall maintain proper temperature in the conditioned space. Economizer shall be equipped with an automatic lockout when the outdoor high ambient temperature is too high for proper cooling. Minimum position control shall be standard and adjustable at the Human Interface Panel or with a remote potentiometer or through the building management system. A spring return motor shall ensure closure of OA dampers during unit shutdown or power interruption. Mechanical cooling shall be available to aid the economizer mode at any ambient. Low leak economizer dampers shall be standard with a leakage rate of 2.5 percent of nominal airflow (400 CFM/ton) at 1" wg. static pressure.

### **Economizer Control with Comparative Enthalpy**

Two enthalpy sensors shall be provided to compare total heat content of the indoor air and outdoor air to determine the most efficient air source when economizing.

### **High efficiency throwaway, MERV 8**

Shall be two-inch high efficiency MERV 8 media filters with average dust spot efficiency of 25-35 percent and an average arrestance in excess of 90 percent when tested in accordance with ASHRAE 52-76.

## Unit Controller

DDC microprocessor controls shall be provided to control all unit functions. The control system shall be suitable to control CV or VAV applications. The controls shall be factory-installed and mounted in the main control panel. All factory-installed controls shall be fully commissioned (run tested) at the factory. The unit shall have a Human Interface Panel with a 16 key keypad, a 2 line X 40 character clear English display as standard to provide the operator with full adjustment and display of control data functions. The unit controls shall be used as a stand-alone controller, or as part of a building management system involving multiple units.

1

The unit shall be equipped with a complete microprocessor control system. This system shall consist of temperature and pressure (thermistor and transducer) sensors, printed circuit boards (modules), and a unit mounted Human Interface Panel. Modules (boards) shall be individually replaceable for ease of service. All microprocessors, boards and sensors shall be factory mounted, wired and tested. The microprocessor boards shall be stand-alone DDC controls not dependent on communications with an on-site PC or a Building Management Network. The microprocessors shall be equipped with on-board diagnostics, indicating that all hardware, software and interconnecting wiring are in proper operating condition. The modules (boards) shall be protected to prevent RFI and voltage transients from affecting the board's circuits. All field wiring shall be terminated at separate, clearly marked terminal strip. Direct field wiring to the I/O boards is not acceptable. The microprocessor's memory shall be non-volatile EEPROM type requiring no battery or capacitive backup, while maintaining all data.

2

Zone sensors shall be available in several combinations with selectable features depending on sensor.

3

The Human Interface Panel's keypad display character format shall be 40 characters x 2 lines. The character font shall be 5 x 7 dot matrix plus cursor. The display shall be Supertwist Liquid Crystal Display (LCD) with blue characters on a ray/green background which provides high visibility and ease of interface. The display format shall be in clear English. Two or three digit coded displays are not acceptable.

4

The keypad shall be equipped with 16 individual touch-sensitive membrane key switches. The switches shall be divided into four separate sections and be password protected from change by unauthorized personnel. The six main menus shall be STATUS, SETPOINTS, DIAGNOSTICS, SETUP, CONFIGURATION and SERVICE MODE.

## BACnet Communication Interface Module

Option shall provide control and monitoring of the rooftop by Tracer SC or a 3rd party building management system utilizing BACnet protocol.

## Unit Interrupt Rating (Standard Short Circuit Current Rating-SCCR)

A 5,000 Amp rating shall be applied to the unit enclosure using a non-fused circuit breaker for disconnect switch purposes. Fan motors, compressors, and electric heat circuits shall be provided with protective devices that will provide the unit rated level of fault protection. The unit shall be marked with approved cULus markings and will adhere to cULus regulations.

## Factory Powered GFI Convenience Outlet

A15A, 115V Ground Fault Interrupter convenience outlet shall be factory installed. It shall be wired and powered from a factory mounted transformer. Unit-mounted, non-fused disconnect with external handle shall be furnished with factory powered outlet

## Non-Fused Disconnect Switch with External Handle

External handle SHALL enable the operator to disconnect unit power with the control box door closed for safety.

## Wall Mounted Humidity Sensor

Shall monitor the humidity levels in the space for 1) Humidification and/or 2) Hot Gas Reheat Dehumidification.



**Equipment manufactured by Trane that includes required start-up and sold in North America will not be warranted by Trane unless Trane or its authorized independent Trane commercial sales office performs the startup on the equipment.**

**Certified AHRI Performance**

Packaged Rooftop units cooling, heating capacities and efficiencies are rated within the scope of the Air-Conditioning, Heating & Refrigeration Institute (AHRI) Certification Program and display the AHRI Certified® mark as a visual confirmation of conformance to the certification sections of AHRI Standard 340-360 (I-P) and ANSI Z21.47 and 10 CFR Part 431 pertaining to Commercial Warm Air Furnaces. The applications in this catalog specifically excluded from the AHRI certification program are:

- Ventilation modes
- Heat Recovery.
- Units larger than nominal 63 tons in Cooling
- Evaporative Condensers

# Fan Details

Unit Size

Operating Brake Power

25.03 bhp

Operating Airflow 22,500 cfm

Altitude

0.00 ft

Operating Static Pressure 3.217 in H2O

Design Temp.

78.00 F

Operating RPM 862 rpm

S04

