

HVAC Symbols

	Condensate Drain	EF	Exhaust Fan
	Rectangular or square ductwork: first number indicates dimension of side shown, second number indicates side not shown.	EF	Exhaust Fan with Light
	Duct Exhaust Elbow-Turned up 90°-Rectangular	FD	Fire Damper
	Duct Exhaust Elbow-Turned down 90°-Rectangular	SD	Smoke Damper
	Duct Return Elbow-Turned up 90°-Rectangular	F/SD	Fire/Smoke Damper
	Duct Return Elbow-Turned down 90°-Rectangular	CRD	Ceiling Radiation Damper
	Duct Supply Elbow-Turned up 90°-Rectangular	CR/SD	Ceiling Radiation/Smoke Damper
	Duct Supply Elbow-Turned down 90°-Rectangular	VD	Volume Damper
	Direction of Flow		Pipe Turned Down
	Change of Elevation Rise (R), Drop (D)		Pipe Turned Up
	Smoke Detector		Pipe Capped
	Heat Detector		Humidistat
	Mount top of thermostat at 47" AFF		CO2 Sensor
	Ball Valve		Connect to Existing
	Diaphragm Valve	MOD	Motor Operated Damper
	Gate, Angle Valve		Butterfly Valve
	Globe Angle Valve		Gate Valve
	Three Way Valve		Globe Valve
	Check, Spring Valve		Plug Valve
	Quick-Opening Valve		Check, Swing Gate Valve
	Safety or Relief Valve		Pressure-Reducing Regulator Valve
	Square-Head Cock Valve		Quick-Closing Valve
	Air Vent, Manual		Solenoid Valve
	Pipe Guide		Air Vent, Automatic
	Anchor, Main		Air Separator
	Expansion Joint		Anchor, Intermediate
	Flexible Connector		Ball Joint
	Flowmeter, Venturi		Expansion Loop
	Heat Exchanger, Liquid		Flowmeter, Orifice Plate with Flanges
	Pressure Gage and Cock		Flow Switch
	Pump (Indicate Use)		Pitch of Pipe, Rise (R) drop (D)
	Strainer		Pressure Switch
	Strainer, Duplex		Pump Suction Diffuser
	Thermometer Well, Only		Strainer, Blow Off
	Time Clock		Thermometer

Abbreviations

ACC Air cooled condenser	ACC Access door	AD Above finished floor	AFR Above finished roof	AHU Air handling unit	ARCH Architectural	AS Air separator	AVG Average	BDD Balancing	BFC Backdraft Damper	BFP Below finished ceiling	BPH Backflow preventer	B.S. Built in	BHP Broke horse power	BLDG Building	BOD Bottom of duct	CHWR Chilled water coil	CD Ceiling diffuser	CFM Cubic feet per minute	CHWS Chilled water supply	CHWR Chilled water return	CLG Ceiling	CO2 Carbon Dioxide Detector	COND Condensing unit	CONTR Contractor	CONST Constant	CONV Convactor	CX Connect to existing	DCW Domestic cold water	DH Dehumidifier	DHW Domestic hot water return	DHWR Domestic hot water return	DIA or Ø Diameter	DN Down	DWG Drawing	DX Direct expansion	DXC Refrigerant coil	EAG Exhaust air grille	EAR Exhaust air register	EAT Entering air temperature	EBB Electric baseboard heater	EC Electrical contractor	EDC Electric duct coil	EF Exhaust fan	ELECT Electrical	ERV Energy recovery ventilator	EUH Electric unit heater	EWH Electric wall heater	EWC Electric water cooler	(E) Existing	FC Forward curved	F Furnace	FT Feet	FTHD Feet of head	FLEX Flexible	FSC Fan speed control	GA Gauge	GALV Galvanized	GC General contractor	GPM Gallons per minute	GEN General	HC Hot water coil	HCWR Heat/chilled water return	HCWS Heat/chilled water supply	HG Hot gas	HP Heat pump	HTG Heating	HTR Heater	HVAC Heating, ventilating and air conditioning	HV Heating and ventilating	HORIZ Horizontal	HP Horse power	HPWR Heat pump water return	HPWS Heat pump water supply	HW Hot water	HWR Hot water return	HWS Hot water supply	IE Invert elevation	IN Inches	IRTH Infrared tube	LAT Leaving air temperature	LBD Linear bar diffuser	LBS/LB Pounds or pound	MA Mixed air	MAX Maximum	MBH 1000 British thermal units per hour	MECH Mechanical	MC Mechanical contractor	MFR Manufacturer	MH Manhole	MIN Minimum	MOD Motor Operated Damper	MTG Mounting	MUA Make-up air	MUW Make-up water	NA Not applicable	NTS Not to scale	OA Outside air	OAI Outside air intake	OED Open end duct	PC Plumbing contractor	PD Pressure drop	PLUM Plumbing	PRESS Pressure	PROP Propeller	PTAC Packaged terminal air-conditioner	RA Return air	RAG Return air grille	RAR Return air register	RCH Radiant Ceiling Heater	REG Register	REQ'D Required	RL Refrigerant liquid	RLX Relocate existing	RM Room	RPM Revolutions per minute	RS Refrigerant suction	RTU Roof top unit	RX Remove existing	SA Supply air	SAN Sanitary	SAR Supply air register	SF Supply fan	SFR Supply floor register	SC Soffit grille	SHTMTL Sheet metal	STD Standard	STM Storm	STRUCT Structural	SP Static pressure	SPD Sump pump discharge	SPLD Splitter damper	SOFT Square feet	SS Stainless steel	SUCT Suction	SYS System	TCP Temperature control panel	TEMP Temperature	AT Temperature difference	TG Transfer grille	THERM Thermometer	THRD Threaded	TSP Total static pressure	TYP Typical	UH Unit heater	UL Underwriters laboratory	UNO Unless Noted Otherwise	V Vent	VEST Vestibule	W/ With	WP Working point	WSHP Water source heat pump
-----------------------------	--------------------	----------------------------	----------------------------	--------------------------	-----------------------	---------------------	----------------	------------------	-------------------------	-------------------------------	---------------------------	------------------	--------------------------	------------------	-----------------------	----------------------------	------------------------	------------------------------	------------------------------	------------------------------	----------------	--------------------------------	-------------------------	---------------------	-------------------	-------------------	---------------------------	----------------------------	--------------------	----------------------------------	-----------------------------------	----------------------	------------	----------------	------------------------	-------------------------	---------------------------	-----------------------------	---------------------------------	----------------------------------	-----------------------------	---------------------------	-------------------	---------------------	-----------------------------------	-----------------------------	-----------------------------	------------------------------	-----------------	----------------------	--------------	------------	----------------------	------------------	--------------------------	-------------	--------------------	--------------------------	---------------------------	----------------	----------------------	-----------------------------------	-----------------------------------	---------------	-----------------	----------------	---------------	---	-------------------------------	---------------------	-------------------	--------------------------------	--------------------------------	-----------------	-------------------------	-------------------------	------------------------	--------------	-----------------------	--------------------------------	----------------------------	---------------------------	-----------------	----------------	--	--------------------	-----------------------------	---------------------	---------------	----------------	------------------------------	-----------------	--------------------	----------------------	----------------------	---------------------	-------------------	---------------------------	----------------------	---------------------------	---------------------	------------------	-------------------	-------------------	---	------------------	--------------------------	----------------------------	-------------------------------	-----------------	-------------------	--------------------------	--------------------------	------------	-------------------------------	---------------------------	----------------------	-----------------------	------------------	-----------------	----------------------------	------------------	------------------------------	---------------------	-----------------------	-----------------	--------------	----------------------	-----------------------	----------------------------	-------------------------	---------------------	-----------------------	-----------------	---------------	----------------------------------	---------------------	------------------------------	-----------------------	----------------------	------------------	------------------------------	----------------	-------------------	-------------------------------	-------------------------------	-----------	-------------------	------------	---------------------	--------------------------------

Schedules of through penetration firestop systems

Concrete Floors				Concrete or Block Walls			
Type of penetrant	(HR)	UL-Classified system	Type of penetrant	(HR)	UL-Classified system	Type of penetrant	(HR)
Circular blank openings	3	C-AJ-0055	Circular blank openings	3	C-AJ-0055		
Single metal pipes or conduit	3	C-AJ-1226	Single metal pipes or conduit	3	C-AJ-1226		
Single non-metallic pipe or conduit (I.E. PVC, CPVC, ABS, FRP, ENT)	3	C-AJ-2342	Single non-metallic pipe or conduit (I.E. PVC, CPVC, ABS, FRP, ENT)	3	C-AJ-2342		
Single or bundled cables	3	C-AJ-3095	Single or bundled cables	3	C-AJ-3095		
Single insulated pipes	2	C-AJ-5090	Single insulated pipes	2	C-AJ-5090		
Electrical busway	3	C-AJ-6006	Electrical busway	3	C-AJ-6006		
Non-insulated mechanical ductwork without dampers	3	C-AJ-7046, C-AJ-7084	Non-insulated mechanical ductwork without dampers	2	W-J-7021, W-J-7022		
Insulated mechanical ductwork without dampers	N/A	N/A	Insulated mechanical ductwork without dampers	2	W-J-7029		
Mixed penetrants	2	C-AJ-8255	Mixed penetrants	2	C-AJ-8255		
Wood Floor-Ceiling				Gypsum Wallboard Assemblies			
Type of penetrant	(HR)	UL-Classified system	Type of penetrant	(HR)	UL-Classified system	Type of penetrant	(HR)
Metal pipes or conduit	2	F-C-1009	Metal pipes or conduit	2	W-L-1058, W-L-1164		
Non-metallic pipe or conduit	2	F-C-2232, F-C-2030	Non-metallic pipe or conduit	2	W-L-2078		
Single or bundled cables	2	F-C-3012	Single or bundled cables	2	W-L-3065		
Insulated pipes	2	F-C-5004	Insulated pipes	2	W-L-5028, W-L-5047		
Non-insulated mechanical ductwork without dampers	1	F-C-7013	Non-insulated mechanical ductwork without dampers	2	W-L-7017, W-L-7042, W-L-7155		
Insulated mechanical ductwork without dampers	N/A	N/A	Insulated mechanical ductwork without dampers	2	W-L-7153, W-L-7156		
Mixed penetrants	1	F-C-8026	Mixed penetrants	4	W-L-8069		

See Division 7 specifications for other approved manufacturers.
UL's Online Certifications Directory: www.ul.com/database

Notes:

- Jobsite conditions of each through-penetration firestop system must meet all details of the UL-Classified system selected.
- If jobsite conditions do not match any UL-Classified systems in the schedules above, contact one of the approved manufacturers for alternative systems or engineer judgment drawings.
- Where more than one applicable UL-Classified system is listed in the schedules, choose the UL System which is most economical for each through-penetration firestop system.
- Coordinate work with other trades to assure that penetration opening sizes are appropriate for penetrant locations, and vice versa.
- For 3-hour rated gypsum walls, contact one of the approved manufacturers for a UL-classified system or engineer judgment drawing.

HVAC General Notes

- Permits: Provide work in accordance with current version of applicable national, state, and local codes as determined by the Authorities Having Jurisdiction (AHJs). Applicable codes shall include ANSI A117.1 (latest edition), UFAS (Uniform Federal Accessibility Standards), FHAG (Fair Housing Accessibility Guidelines), and codes listed on cover and interpretations. Contractor shall be responsible for obtaining and paying for permits and inspections. Contractor shall be familiar with applicable codes and local AHJ interpretations before bid and construction.
- Definitions: Furnish means to purchase, arrange for delivery to site, and to take delivery at the site. Install means to place in position for use. Provide means to furnish and install. "HC" means handicap accessible per current ADA, UFAS and ANSI Type A requirements. "SI" means sensory impaired per ADA, UFAS and ANSI requirements.
- Contract Documents: All work shall be performed according to the Contract Documents. The Contract Documents include Architectural, Civil, Structural, Fire Protection, Plumbing, Mechanical, and Electrical design drawings, Specifications, and Addenda, Architect's Supplemental Instructions, Bulletins, Change Orders, and other instruction transmitted to modify the original documents. All of these documents are integral to the project. Refer to the specifications for general requirements, product quality, construction, finish, and for additional installation instructions. Refer to the architectural drawings for accessibility compliance requirements. Before bidding, review and understand the requirements with the Engineer and General Contractor, and again during the pre-construction conference prior to performing the work. Conflicts within or between the Contract Documents and referenced codes shall use the most stringent interpretation until clarified. Clarifications shall be requested in writing and shall be resolved prior to proceeding with installation. Scope changes shall be approved by the Owner, Architect, Engineer, and the General Contractor, prior to proceeding with installation. All costs due to performing work prior to conflict resolution shall be borne by the contractor.
- Coordination: The drawings are diagrammatic, schematic and shown for bidding and general reference. Drawings are not intended to define exact installation details and shall not be scaled. Prior to bid, confirm scope of work with Engineer. Before ordering equipment or supplies, coordinate scope requirements with suppliers and submit product data to Engineer for review. Prior to construction, attend truss coordination/pre-installation conference to coordinate structure requirements and before installing work verify existing conditions match previous coordination. Coordinate exact dimensions and sequencing with all other trades including but not limited to site, utilities, and framing subcontractor. All additional costs resulting from lack of coordination shall be borne by the contractor.
- Penetrations: Penetrations through structure shall be coordinated with structural elements, including studs, joists and trusses, before ordering materials or structure construction. Membrane and through penetrations of fire/smoke rated construction shall be protected with a product listed and labeled to maintain the rating of system penetrated. Penetrations through walls, slabs, masonry, etc. shall do so through sleeves. All gaps outside and shall be caulked or be tightly packed in order to maintain proper protection against fire, smoke, heat loss, moisture, air infiltration, sound transmission, etc.
- Contractor Deviations: Deviations from the design shall be approved by the Architect and Engineer before ordering supplies or starting work. Alternate products and/or system layouts must be approved in writing prior to bid in order to be accepted. If submitted products are not specified, they are substitutions and shall be submitted for consideration under substitution procedures. Contractor shall be responsible for design and performance of proposed substitutions, even if accepted by owner and added to construction documents. All costs associated with dimensional, performance, or other deviations from basis of design including but not limited to, engineering, permitting, and other affected trades, shall be borne by the contractor.
- Incidentals: Provide materials, labor, and incidental work (including protection of existing, surface preparation, hangars, and other appurtenances) to provide complete working HVAC systems for the project. Offsets, fittings, accessories, and miscellaneous hardware are not shown, but shall be included at no additional cost in order to complete the system.
- Warranty: To obtain final project certificates of occupancy upon completion of the work scope, contractor shall warrant that the work has been completed in compliance with established codes and regulations. Certificate shall be given to owner at project completion.
- Coordinate radiation/fire dampers with structural assembly/structural shop drawings before ordering. Verify damper outside dimensions fit inside the dimensional clearances of the structural assembly and advise if changes are needed. Verify damper is listed for the application - horizontal or vertical, and concrete, wood, or truss. Verify the UL listing of the damper includes UL listing for the rated assembly and verify the UL listing of rated assembly includes the damper manufacturer and model number. Install all dampers according to manufacturer's instructions.
- Condensate Drains: Trap for condensate drain shall be 1" deeper than the total possible static pressure that the air handling unit can develop. Trap outlet shall be lower than inlet by 1" more than total static pressure.
- Piping in exterior walls shall be run inside of building insulation. Provide metal jacket up 8" O" A.F.F. on all exposed insulated piping. Trapeze hangers may be used when grouping pipes.
- Air Ducts: Duct leakage shall be less than 4.0 CFM at 25 pascals/100 SF of conditioned floor area. Ducts shall run within thermal envelope. Air distribution within walls shall be fully ducted-no exposed studs, drywall, or sheathing. Ducts run outside thermal envelope shall have R-8 insulation minimum.
- Refrigerant: Provide Non-HCFC HVAC refrigerant, charge per manufacturer requirements. Forward test and refrigerant data to builder and green rater when complete.
- Ceiling Access Panels: Provide one 36" x 36" ceiling access panel for each item of equipment located above a drywall ceiling. Provide one 24" x 24" ceiling access panel for each valve (including but not limited to balance and control valves, or damper (including but not limited to balance, fire, smoke and/or combination fire/smoke dampers). Coordinate access panel locations and show recommended locations on coordination drawings along with equipment, valves, dampers, structure, lights, and ceiling air devices.
- Machine rooms and flexible connectors shall not exceed 5'-0" in length. 10 inches WG positive and 1.0 WG negative. R-value 4.2 within thermal envelope, R-value 8.0 outside thermal envelope. See specifications for additional requirements.
- Hoistway exterior surfaces shall be insulated by the GC to code minimum (R-20 walls and R-38 roof) and provide door seals and vestibule at unconditioned levels. When building is fully conditioned to remain between 70 and 75 degrees F, calculations show that stack effect will provide adequate ventilation to keep the hoistway equipment within design parameters.
- Machine Room Less (MRL) elevators shall be selected by the GC to safely operate between 41 and 104 degrees F (5-40 degrees C). A 15HP or smaller motor generates 73 BTU requiring 160 Cuft of airflow per minute of operation. Each closed elevator door allows 650 cfm of infiltration (3.5' x 7' door with .2" crack at .3" WC pressure) according to ASHRAE Fundamentals Handbook. A draft pressure of .1" WC/floor is created naturally through stack effect. Piston effect produces an additional .03" WG pressure above and below the car creating additional infiltration during operation. For MRL elevators with motors larger than 15HP, provide an inline exhaust fan ducted from hoistway with minimum 150 cfm, power wiring, motor operated damper, and thermostat with remote sensing probe set for 90 degrees F. When not in use, elevator doors shall open to allow unrestricted airflow into the hoistway when not in operation. At substantial completion, the GC shall place a permanent placard showing acceptable temperature and humidity range.
- Materials exposed within plenums shall be noncombustible or have a flame spread index of 25 or less and a smoke-developed index of 50 or less.

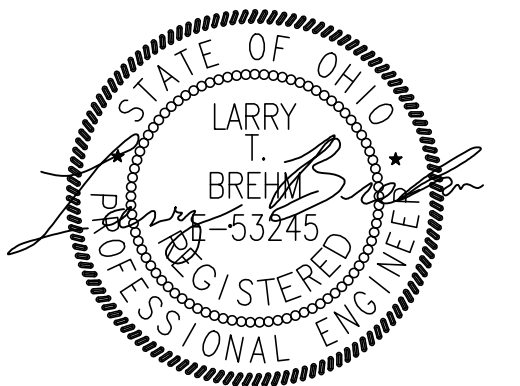

BENNETT POINT
 BLDG 1 - 600 E 12TH STREET
 BLDG 2 - 528 E 12TH STREET
 CINCINNATI, OHIO

© 2021 BY:
 BERARDI + PARTNERS, INC.
 ARCHITECTS AND ENGINEERS
 ALL RIGHTS RESERVED

THE ARRANGEMENTS DEPICTED HEREIN ARE THE SOLE PROPERTY OF BERARDI + PARTNERS, INC. ARCHITECTS AND ENGINEERS AND MAY NOT BE REPRODUCED WITHOUT ITS WRITTEN PERMISSION.

- NOTE:
- ALL BIDDERS SHALL VISIT THE SITE AND BECOME FAMILIAR WITH THE EXISTING CONDITIONS AND REQUIREMENTS OF THE PROJECT AND SHALL NOTIFY THE ARCHITECT OF ANY ERRORS AND OMISSIONS SUBSEQUENTLY DISCOVERED IN THE CONTRACT DOCUMENTS.
 - THE CONTRACT DOCUMENTS ARE CONSIDERED TO BE THE ENTIRETY OF THE CONTRACT DOCUMENTS. THE INFORMATION IN THESE DOCUMENTS IS DEPENDENT UPON AND COMPLEMENTARY TO EACH OTHER. SEPARATION OF THE CONTRACT DOCUMENTS SHALL NOT BE PERMITTED. IF THE CONTRACTOR CHOOSES TO SEPARATE THE DOCUMENTS, THEY DO SO AT THEIR OWN RISK AND EXPENSE.
 - ADDITIONAL SEE GENERAL INFORMATION ON "A0" SHEETS.
 - THE CLIENT ACKNOWLEDGES THE CONSULTANTS (ARCHITECT, ENGINEER, AND SPECIFICATION WRITER) SHALL NOT BE RESPONSIBLE FOR THE SEPARATION OF THE CONTRACT DOCUMENTS INCLUDING ALL DOCUMENTS ON ELECTRONIC MEDIA AS INSTRUMENTS OF THE CONSULTANTS (ARCHITECT) PROFESSIONAL SERVICE. THE CLIENT SHALL NOT REUSE OR MAKE OR PERMIT TO BE MADE ANY MODIFICATION TO THE DRAWINGS AND SPECIFICATIONS WITHOUT THE PRIOR WRITTEN AUTHORIZATION OF THE CONSULTANT (ARCHITECT). THE CLIENT AGREES TO WAIVE ANY CLAIM AGAINST THE CONSULTANT (ARCHITECT) ARISING FROM ANY UNAUTHORIZED REUSE OR MODIFICATION OF THE DRAWINGS AND SPECIFICATIONS.
 - ARCHITECT CANNOT WARRANT THE ACCURACY OF DATA CONTAINED HEREIN ANY USE OR REUSE OF ORIGINAL OR ALTERED DESIGN MATERIALS BY THE USER OR OTHER PARTIES WITHOUT THE REVIEW AND WRITTEN APPROVAL OF THE ARCHITECT SHALL BE AT THE SOLE RISK OF THE USER. FURTHERMORE, USER AGREES TO DEFEND, INDEMNIFY, AND HOLD ARCHITECT HARMLESS FROM ALL CLAIMS, DAMAGES, LOSSES, EXPENSES AND ATTORNEY'S FEES ARISING OUT OF THE MODIFICATION OR REUSE OF THESE MATERIALS.
 - THESE DRAWINGS AS PART OF THE CONTRACT DOCUMENTS ARE DIAGRAMMATIC AND ARE NOT INTENDED TO DEFINE EXACT QUANTITIES. LOCATIONS OR CODED REQUIREMENTS. THE DRAWINGS SHALL NOT BE SCALED EXACT. STATE AND LOCAL CODE REQUIREMENTS AND OTHER APPLICABLE CODE REQUIREMENTS SHALL BE VERIFIED BY AND ARE THE SOLE RESPONSIBILITY OF THE CONTRACTOR. ANY INFORMATION WHICH DIRECTLY CONFLICTS WITH ANY OF THESE CODES OR ANY DISCREPANCIES FOUND IN THE CONTRACT DOCUMENTS SHALL BE BROUGHT TO THE ATTENTION OF THE PROJECT ARCHITECT.

PERMIT SET

PROJECT DATE: 11.17.2020
 PROJECT #: 19187

#	Description	Date
---	-------------	------

MECHANICAL NOTES, SYMBOLS AND ABBREVIATIONS

M.001

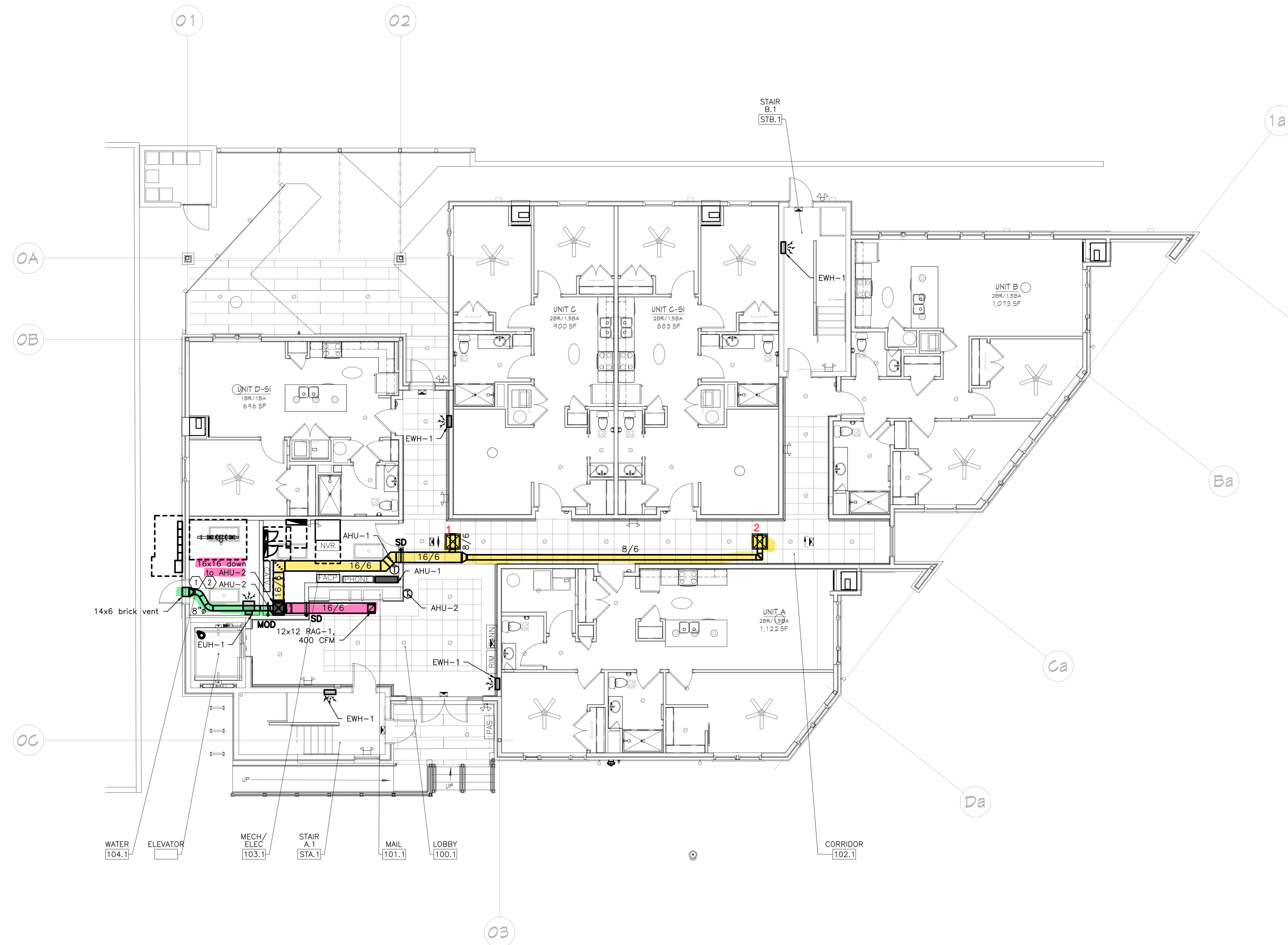

BENNETT POINT

BLDG 1 - 600 E 12TH STREET
BLDG 2 - 528 E 12TH STREET
CINCINNATI, OHIO

© 2021 BY:
BERARDI + PARTNERS, INC.
ARCHITECTS AND ENGINEERS
ALL RIGHTS RESERVED

THE ARRANGEMENTS DEPICTED HEREIN ARE THE SOLE PROPERTY OF BERARDI + PARTNERS, INC. ARCHITECTS AND ENGINEERS, AND MAY NOT BE REPRODUCED WITHOUT ITS WRITTEN PERMISSION.

- NOTE:
1. ALL BIDDERS SHALL VISIT THE SITE AND BECOME FAMILIAR W/ THE EXISTING CONDITIONS AND REQUIREMENTS OF THE PROJECT AND SHALL NOTIFY THE ARCHITECT OF ANY ERRORS AND OMISSIONS SUBSEQUENTLY DISCOVERED IN THE CONTRACT DOCUMENTS.
 2. THE CONTRACT DOCUMENTS ARE COMPRISED OF THE DRAWINGS AND THE PROJECT MANUAL. IN SEPARATION OF THE CONTRACT DOCUMENTS, THEIR ENTIRETY, THE INFORMATION IN THESE DOCUMENTS IS DEPENDENT UPON AND COMPLEMENTARY OF EACH OTHER.
 3. SEPARATION OF THE CONTRACT DOCUMENTS SHALL NOT BE PERMITTED, IF THE CONTRACTOR CHOOSES TO SEPARATE THE DOCUMENTS, THEY DO SO AT THEIR OWN RISK AND EXPENSE.
 4. ADDITIONALLY SEE GENERAL INFORMATION ON "A0" SHEETS.
 5. THE CLIENT ACKNOWLEDGES THE CONSULTANTS (ARCHITECT) PROFESSIONAL SERVICE. THE CLIENT SHALL NOT REUSE OR MAKE OR PERMIT TO BE MADE ANY MODIFICATION TO THE DRAWINGS AND SPECIFICATIONS WITHOUT THE PRIOR WRITTEN AUTHORIZATION OF THE CONSULTANT (ARCHITECT). THE CLIENT AGREES TO WAIVE ANY CLAIM AGAINST THE CONSULTANT (ARCHITECT) ARISING FROM ANY UNAUTHORIZED TRANSFER, REUSE OR MODIFICATION OF THE DRAWINGS AND SPECIFICATIONS.
 6. ARCHITECT CANNOT WARRANT THE ACCURACY OF DATA CONTAINED HEREIN. ANY USE OR REUSE OF ORIGINAL OR ALTERED CAD DESIGN MATERIALS BY THE USER OR OTHER PARTIES WITHOUT THE REVIEW AND WRITTEN APPROVAL OF THE ARCHITECT SHALL BE AT THE SOLE RISK OF THE USER. FURTHERMORE, USER AGREES TO DEFEND, INDEMNIFY, AND HOLD ARCHITECT HARMLESS FROM ALL CLAIMS, INJURIES, DAMAGES, LOSSES, EXPENSES AND ATTORNEY'S FEES ARISING OUT OF THE MODIFICATION OR REUSE OF THESE MATERIALS.
 7. THESE DRAWINGS AS PART OF THE CONTRACT DOCUMENTS ARE DIAGNOSTIC AND ARE NOT INTENDED TO DEFINE EXACT QUANTITIES. LOCATIONS OR CODED REQUIREMENTS. THE DRAWINGS SHALL NOT BE SCALED EXACT. STATE AND LOCAL CODE REQUIREMENTS AND OTHER APPLICABLE CODE REQUIREMENTS SHALL BE VERIFIED BY AND ARE THE SOLE RESPONSIBILITY OF THE CONTRACTOR. ANY INFORMATION WHICH DIRECTLY CONFLICTS WITH ANY OF THESE CODES OR ANY DISCREPANCIES FOUND IN THE CONTRACT DOCUMENTS SHALL BE BROUGHT TO THE ATTENTION OF THE PROJECT ARCHITECT.

PERMIT SET

PROJECT DATE: 11.17.2020
PROJECT #: 19187

#	Description	Date
1	90% Drawing Set	11.17.2020

Coded Notes

1. Dashed line represents required clearance/access to equipment.
2. Route condensate drain indirectly to nearest floor/hub drain with 2" air gap.
3. Ductwork routed within dropped ceiling/soffit.
4. Flush mounted louvered shutter.
5. 4" routed from dryer vent box to flush mounted louvered shutter.
6. Thermostat mounted 47" AFF at top. Provide clear locking Lexan cover. All covers keyed alike.

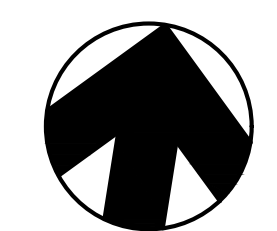

north BUILDING 1 - FIRST FLOOR PLAN
1/8"=1'-0"

MECHANICAL
BUILDING 1 FIRST
FLOOR PLAN

M.101.1

BENNETT POINT

BLDG 1 - 600 E 12TH STREET
BLDG 2 - 528 E 12TH STREET
CINCINNATI, OHIO

© 2021 BY:
BERARDI + PARTNERS, INC.
ARCHITECTS AND ENGINEERS
ALL RIGHTS RESERVED

THE ARRANGEMENTS DEPICTED HEREIN ARE THE SOLE PROPERTY OF BERARDI + PARTNERS, INC. ARCHITECTS AND ENGINEERS, AND MAY NOT BE REPRODUCED WITHOUT ITS WRITTEN PERMISSION.

- NOTE:
1. ALL BIDDERS SHALL VISIT THE SITE AND BECOME FAMILIAR WITH THE EXISTING CONDITIONS AND REQUIREMENTS OF THE PROJECT AND SHALL NOTIFY THE ARCHITECT OF ANY ERRORS AND OMISSIONS SUBSEQUENTLY DISCOVERED IN THE CONTRACT DOCUMENTS.
 2. THE CONTRACT DOCUMENTS ARE COMPRISED OF THE DRAWINGS AND THE PROJECT MANUAL. IN SEPARATION OF THE CONTRACT DOCUMENTS SHALL NOT BE PERMITTED, IF THE CONTRACTOR CHOOSES TO SEPARATE THE DOCUMENTS, THEY DO SO AT THEIR OWN RISK AND EXPENSE.
 3. ADDITIONALLY SEE GENERAL INFORMATION ON "A0" SHEETS.
 4. THE CLIENT ACKNOWLEDGES THE CONSULTANTS (ARCHITECT) DRAWINGS AND SPECIFICATION INCLUDING ALL DOCUMENTS ON ELECTRONIC MEDIA AS INSTRUMENTS OF THE CONSULTANTS (ARCHITECT) PROFESSIONAL SERVICE. THE CLIENT SHALL NOT REUSE OR MAKE OR PERMIT TO BE MADE ANY MODIFICATION TO THE DRAWINGS AND SPECIFICATIONS WITHOUT THE PRIOR WRITTEN AUTHORIZATION OF THE CONSULTANT (ARCHITECT). THE CLIENT AGREES TO WAIVE ANY CLAIM AGAINST THE CONSULTANT (ARCHITECT) ARISING FROM ANY UNAUTHORIZED TRANSFER, REUSE OR MODIFICATION OF THE DRAWINGS AND SPECIFICATIONS.
 5. ARCHITECT CANNOT WARRANT THE ACCURACY OF DATA CONTAINED HEREIN. ANY USE OR REUSE OF ORIGINAL OR ALTERED CAD DESIGN MATERIALS BY THE USER OR OTHER PARTIES WITHOUT THE REVIEW AND WRITTEN APPROVAL OF THE ARCHITECT SHALL BE AT THE SOLE RISK OF THE USER. FURTHERMORE, USER AGREES TO DEFEND, INDEMNIFY, AND HOLD ARCHITECT HARMLESS FROM ALL CLAIMS, INJURIES, DAMAGES, LOSSES, EXPENSES AND ATTORNEY'S FEES ARISING OUT OF THE MODIFICATION OR REUSE OF THESE MATERIALS.
 6. THESE DRAWINGS AS PART OF THE CONTRACT DOCUMENTS ARE DIAGNOSTIC AND ARE NOT INTENDED TO DEFINE EXACT QUANTITIES. LOCATIONS OR CODED REQUIREMENTS. THE DRAWINGS SHALL NOT BE SCALED EXACT. STATE AND LOCAL CODE REQUIREMENTS AND OTHER APPLICABLE CODE REQUIREMENTS SHALL BE VERIFIED BY AND ARE THE SOLE RESPONSIBILITY OF THE CONTRACTOR. ANY INFORMATION WHICH DIRECTLY CONFLICTS WITH ANY OF THESE CODES OR ANY DISCREPANCIES FOUND IN THE CONTRACT DOCUMENTS SHALL BE BROUGHT TO THE ATTENTION OF THE PROJECT ARCHITECT.

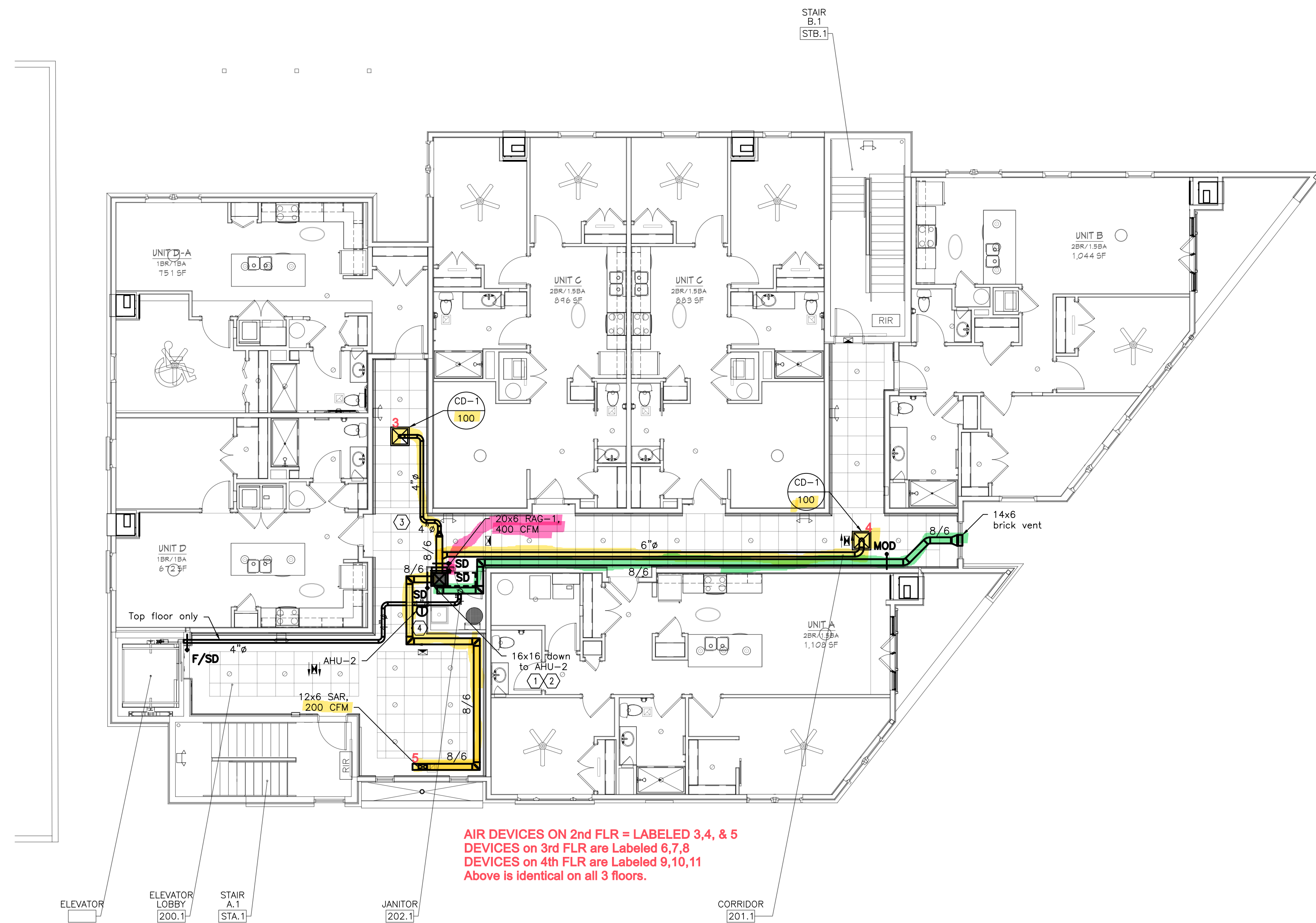

AIR DEVICES ON 2nd FLR = LABELED 3, 4, & 5
DEVICES on 3rd FLR are Labeled 6, 7, 8
DEVICES on 4th FLR are Labeled 9, 10, 11
Above is identical on all 3 floors.

PERMIT SET

PROJECT DATE: 11.17.2020
PROJECT #: 19187

#	Description	Date
---	-------------	------

Coded Notes

1. Dashed line represents required clearance/access to equipment.
2. Route condensate drain indirectly to nearest floor/hub drain with 2" air gap.
3. Ductwork routed within dropped ceiling/soffit.
4. Thermostat mounted 47" AFF at top. Provide clear locking Lexan cover. All covers keyed alike.

MECHANICAL
BUILDING 1 SECOND-
FOURTH FLOOR PLAN

M.102.1

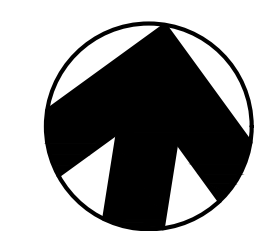

north BUILDING 1 - SECOND - FOURTH FLOOR PLAN
1/8"=1'-0"

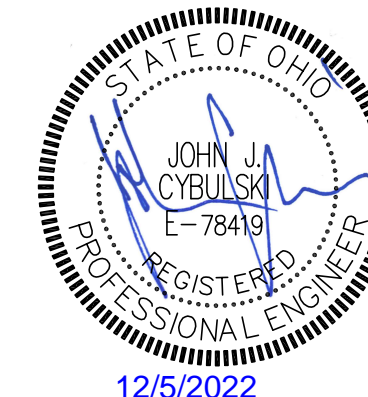

**BENNETT
POINT**

BLDG 1 - 600 E 12TH STREET
BLDG 2 - 528 E 12TH STREET
CINCINNATI, OHIO

© 2021 BY:
BERARDI + PARTNERS, INC.
ARCHITECTS AND ENGINEERS
ALL RIGHTS RESERVED

THE ARRANGEMENTS DEPICTED HEREIN ARE THE SOLE PROPERTY OF BERARDI + PARTNERS, INC. ARCHITECTS AND ENGINEERS, AND MAY NOT BE REPRODUCED WITHOUT ITS WRITTEN PERMISSION.

- NOTE:
1. ALL BIDDERS SHALL VISIT THE SITE AND BECOME FAMILIAR WITH THE EXISTING CONDITIONS AND REQUIREMENTS OF THE PROJECT AND SHALL NOTIFY THE ARCHITECT OF ANY ERRORS AND OMISSIONS SUBSEQUENTLY DISCOVERED IN THE CONTRACT DOCUMENTS.
 2. THE CONTRACT DOCUMENTS ARE COMPRISED OF THE DRAWINGS AND THE PROJECT MANUAL. IN SEPARATION OF THE CONTRACT DOCUMENTS SHALL NOT BE PERMITTED, IF THE CONTRACTOR CHOOSES TO SEPARATE THE DOCUMENTS, THEY DO SO AT THEIR OWN RISK AND EXPENSE.
 3. ADDITIONALLY SEE GENERAL INFORMATION ON "A0" SHEETS.
 4. THE CLIENT ACKNOWLEDGES THE CONSULTANTS (ARCHITECT) DRAWINGS AND SPECIFICATION INCLUDING ALL DOCUMENTS ON ELECTRONIC MEDIA AS INSTRUMENTS OF THE CONSULTANTS (ARCHITECT) PROFESSIONAL SERVICE. THE CLIENT SHALL NOT REUSE OR MAKE OR PERMIT TO BE MADE ANY MODIFICATION TO THE DRAWINGS AND SPECIFICATIONS WITHOUT THE PRIOR WRITTEN AUTHORIZATION OF THE CONSULTANT (ARCHITECT). THE CLIENT AGREES TO WAIVE ANY CLAIM AGAINST THE CONSULTANT (ARCHITECT) ARISING FROM ANY UNAUTHORIZED TRANSFER, REUSE OR MODIFICATION OF THE DRAWINGS AND SPECIFICATIONS.
 5. ARCHITECT CANNOT WARRANT THE ACCURACY OF DATA CONTAINED HEREIN. ANY USE OR REUSE OF ORIGINAL OR ALTERED CAD DESIGN MATERIALS BY THE USER OR OTHER PARTIES WITHOUT THE REVIEW AND WRITTEN APPROVAL OF THE ARCHITECT SHALL BE AT THE SOLE RISK OF THE USER. FURTHERMORE, USER AGREES TO DEFEND, INDEMNIFY, AND HOLD ARCHITECT HARMLESS FROM ALL CLAIMS, INJURIES, DAMAGES, LOSSES, EXPENSES, AND ATTORNEY'S FEES ARISING OUT OF THE MODIFICATION OR REUSE OF THESE MATERIALS.
 6. THESE DRAWINGS AS PART OF THE CONTRACT DOCUMENTS ARE DIAGNOSTIC AND ARE NOT INTENDED TO DEFINE EXACT QUANTITIES. LOCATIONS OR CODED REQUIREMENTS. THE DRAWINGS SHALL NOT BE SCALED EXACT. STATE AND LOCAL CODE REQUIREMENTS AND OTHER APPLICABLE CODE REQUIREMENTS SHALL BE VERIFIED BY AND ARE THE SOLE RESPONSIBILITY OF THE CONTRACTOR. ANY INFORMATION WHICH DIRECTLY CONFLICTS WITH ANY OF THESE CODES OR ANY DISCREPANCIES FOUND IN THE CONTRACT DOCUMENTS SHALL BE BROUGHT TO THE ATTENTION OF THE PROJECT ARCHITECT.

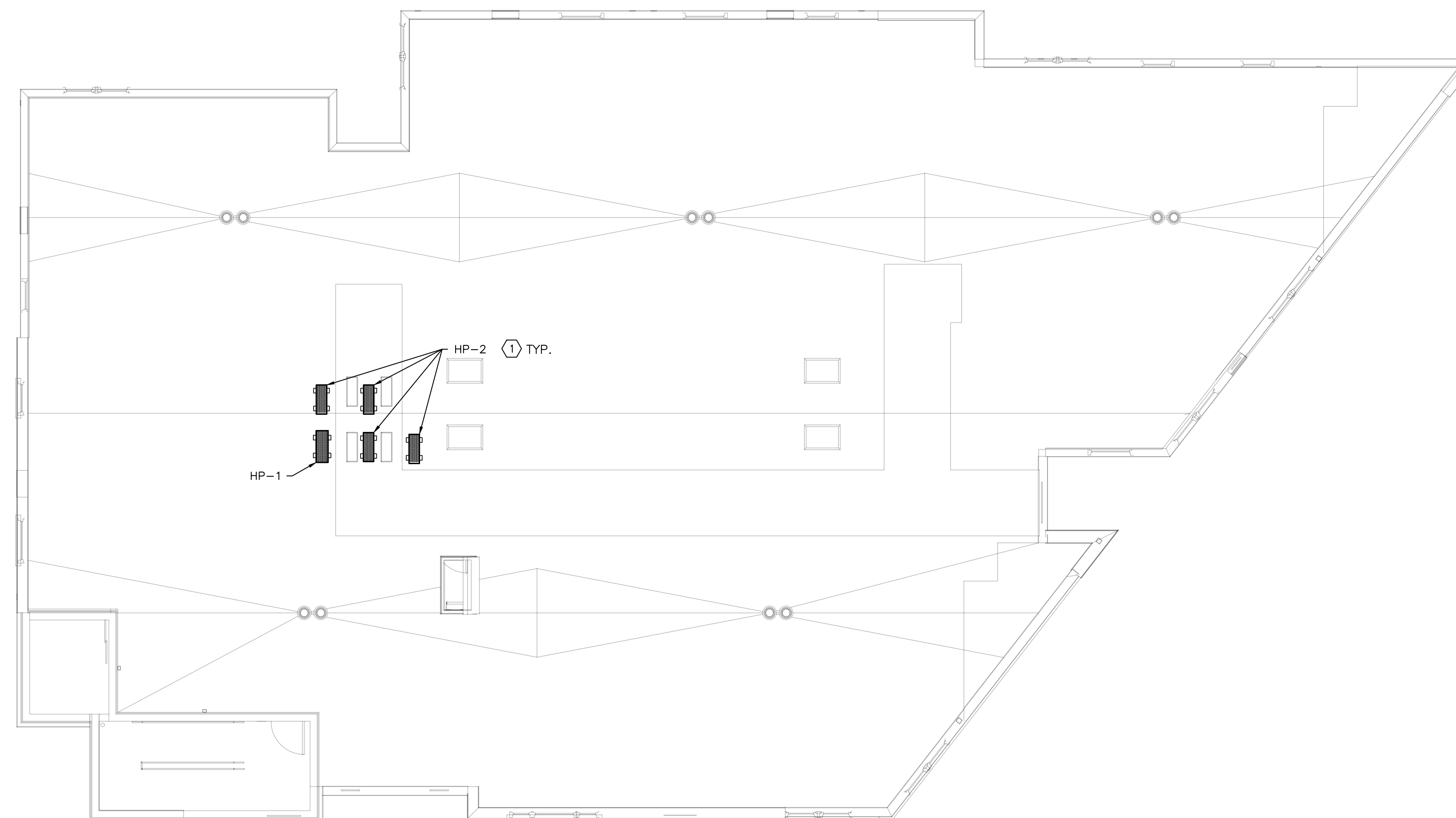

PERMIT SET

PROJECT DATE: 11.17.2020
PROJECT #: 19187

#	Description	Date
1	90% Drawing Set	11.17.2020

Coded Notes

1. Condensing unit mounted on roof. Provide spring vibration isolation, minimum 3/4" deflection.

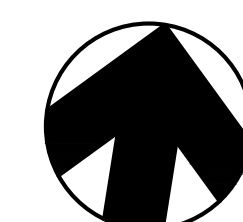

north BUILDING 1 - ROOF PLAN
1/8"=1'-0"

**MECHANICAL
BUILDING 1
ROOF PLAN**

M.103.1

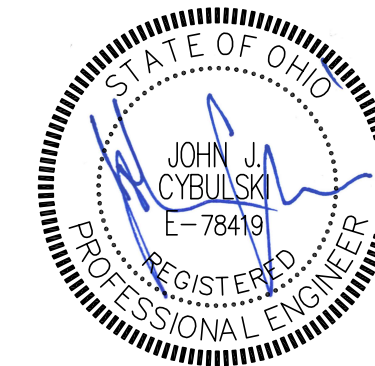

12/1/2022

BENNETT POINT

BLDG 1 - 600 E 12TH STREET
BLDG 2 - 528 E 12TH STREET
CINCINNATI, OHIO

© 2021 BY:
BERARDI + PARTNERS, INC.
ARCHITECTS AND ENGINEERS
ALL RIGHTS RESERVED

THE ARRANGEMENTS DEPICTED HEREIN ARE THE SOLE PROPERTY OF BERARDI + PARTNERS, INC. ARCHITECTS AND ENGINEERS, AND MAY NOT BE REPRODUCED WITHOUT ITS WRITTEN PERMISSION.

NOTE:

- ALL BIDDERS SHALL VISIT THE SITE AND BECOME FAMILIAR WITH THE EXISTING CONDITIONS AND REQUIREMENTS OF THE PROJECT AND SHALL NOTIFY THE ARCHITECT OF ANY ERRORS AND OMISSIONS SUBSEQUENTLY DISCOVERED IN THE CONTRACT DOCUMENTS.
- THE CONTRACT DOCUMENTS ARE COMPRISED OF THE DRAWINGS AND THE PROJECT MANUAL, IN THEIR ENTIRETY. THE INFORMATION IN THESE DOCUMENTS IS DEPENDENT UPON AND COMPLEMENTARY TO EACH OTHER. SEPARATION OF THE CONTRACT DOCUMENTS SHALL NOT BE PERMITTED. IF THE CONTRACTOR CHOOSES TO SEPARATE THE DOCUMENTS, THEY DO SO AT THEIR OWN RISK AND EXPENSE.
- ADDITIONALLY SEE GENERAL INFORMATION ON "A0" SHEETS.
- THE CLIENT ACKNOWLEDGES THE CONSULTANTS (ARCHITECT) DRAWINGS AND SPECIFICATION INCLUDING ALL DOCUMENTS ON ELECTRONIC MEDIA AS INSTRUMENTS OF THE CONSULTANTS (ARCHITECT) PROFESSIONAL SERVICE. THE CLIENT SHALL NOT REUSE OR MAKE OR PERMIT TO BE MADE ANY MODIFICATION TO THE DRAWINGS AND SPECIFICATIONS WITHOUT THE PRIOR WRITTEN AUTHORIZATION OF THE CONSULTANT (ARCHITECT). THE CLIENT AGREES TO WAIVE ANY CLAIM AGAINST THE CONSULTANT (ARCHITECT) ARISING FROM ANY UNAUTHORIZED TRANSFER, REUSE OR MODIFICATION OF THE DRAWINGS AND SPECIFICATIONS.
- ARCHITECT CANNOT WARRANT THE ACCURACY OF DATA CONTAINED HEREIN. ANY USE OR REUSE OF ORIGINAL OR ALTERED DESIGN MATERIALS BY THE USER OR OTHER PARTIES WITHOUT THE REVIEW AND WRITTEN APPROVAL OF THE ARCHITECT SHALL BE AT THE SOLE RISK OF THE USER. FURTHERMORE, USER AGREES TO DEFEND, INDEMNIFY, AND HOLD ARCHITECT HARMLESS FROM ALL CLAIMS, INJURIES, DAMAGES, LOSSES, EXPENSES AND ATTORNEY'S FEES ARISING OUT OF THE MODIFICATION OR REUSE OF THESE MATERIALS.
- THESE DRAWINGS AS PART OF THE CONTRACT DOCUMENTS ARE DIAGNOSTIC AND ARE NOT INTENDED TO DEFINE EXACT QUANTITIES. LOCATIONS OR CODED REQUIREMENTS. THE DRAWINGS SHALL NOT BE SCALED EXACT. STATE AND LOCAL CODE REQUIREMENTS AND OTHER APPLICABLE CODE REQUIREMENTS SHALL BE VERIFIED BY AND ARE THE SOLE RESPONSIBILITY OF THE CONTRACTOR. ANY INFORMATION WHICH DIRECTLY CONFLICTS WITH ANY OF THESE CODES OR ANY DISCREPANCIES FOUND IN THE CONTRACT DOCUMENTS SHALL BE BROUGHT TO THE ATTENTION OF THE PROJECT ARCHITECT.

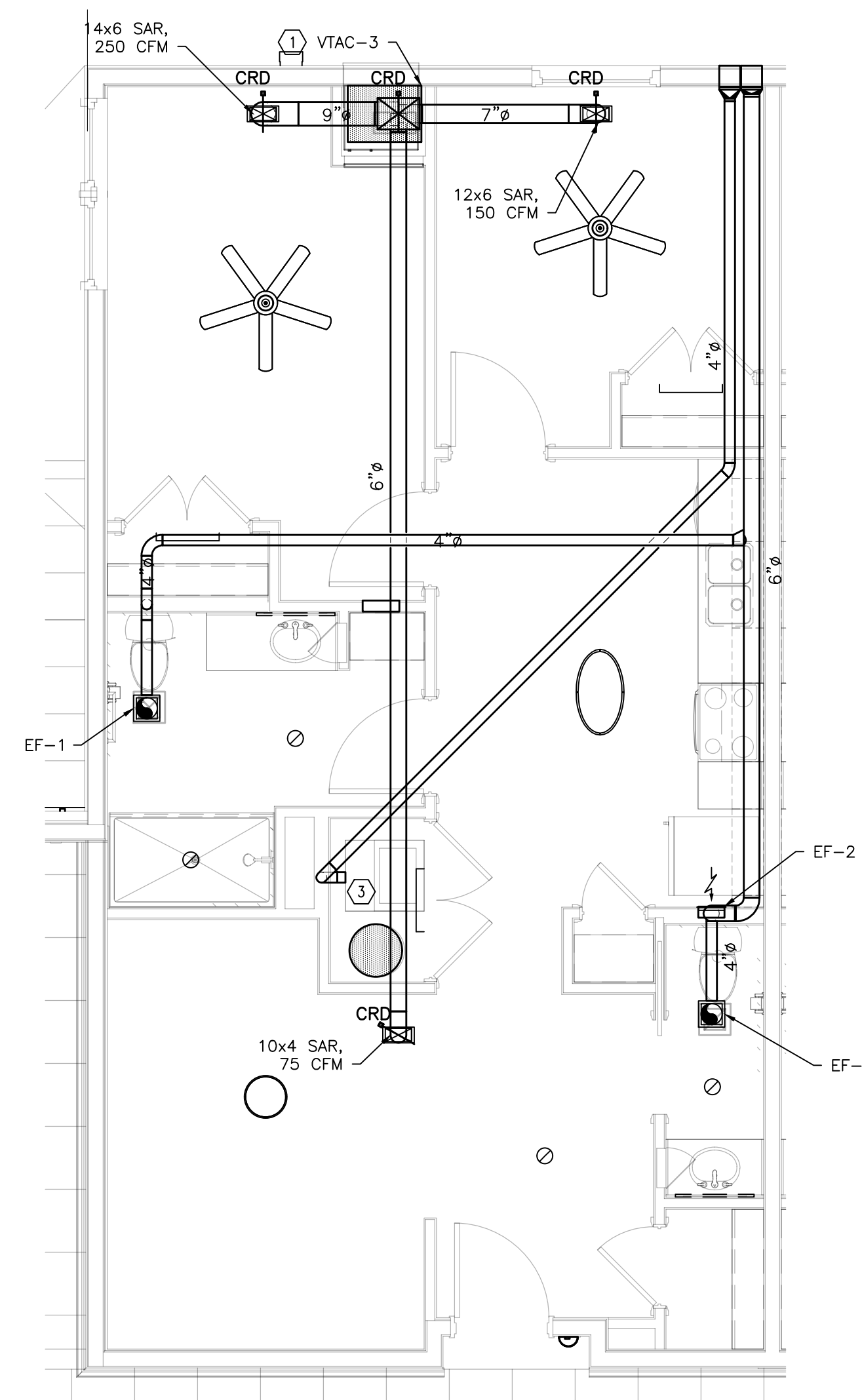

UNIT C - 1BR/1BA
1/4"=1'-0"

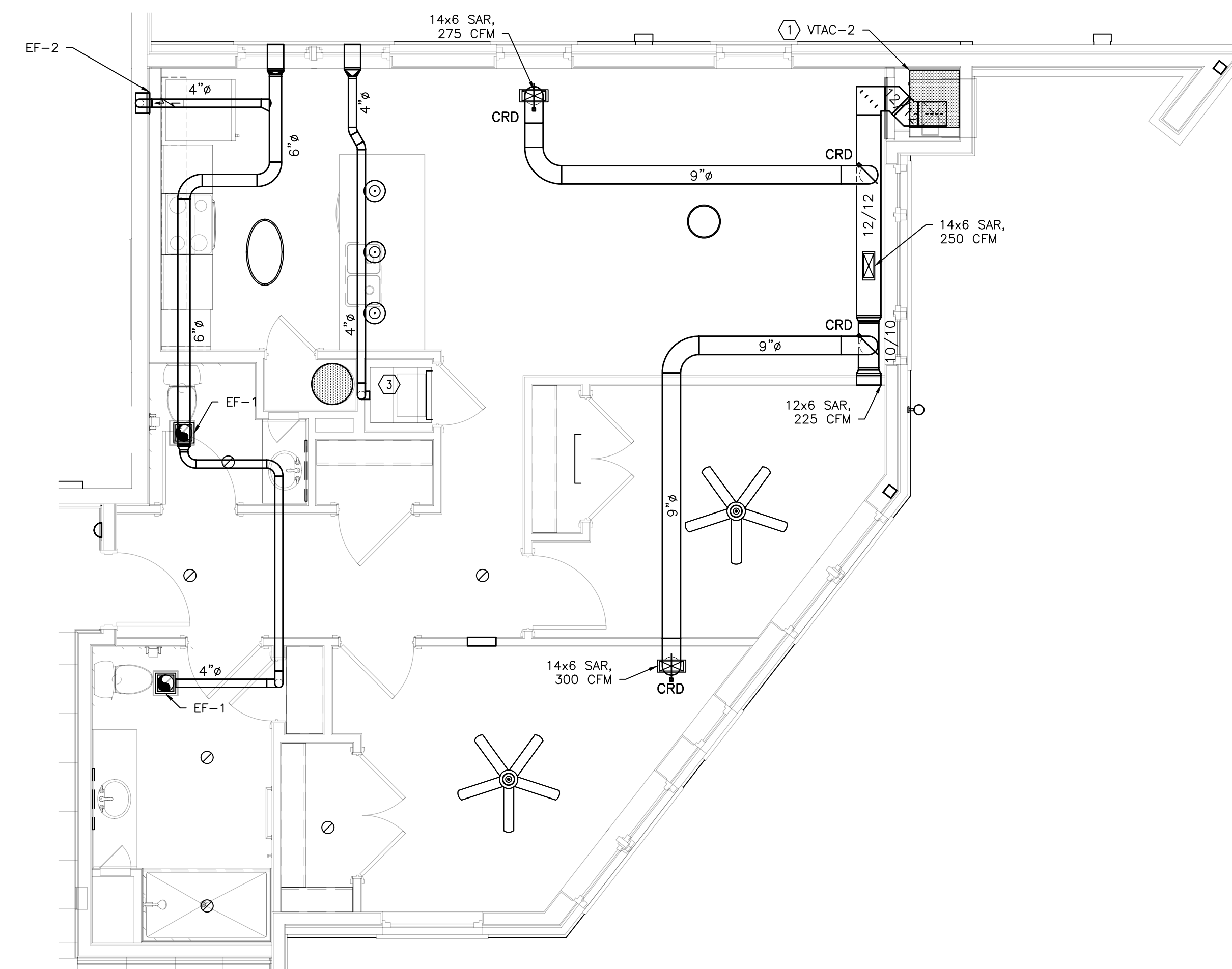

UNIT B - 2BR/1.5BA
1/4"=1'-0"

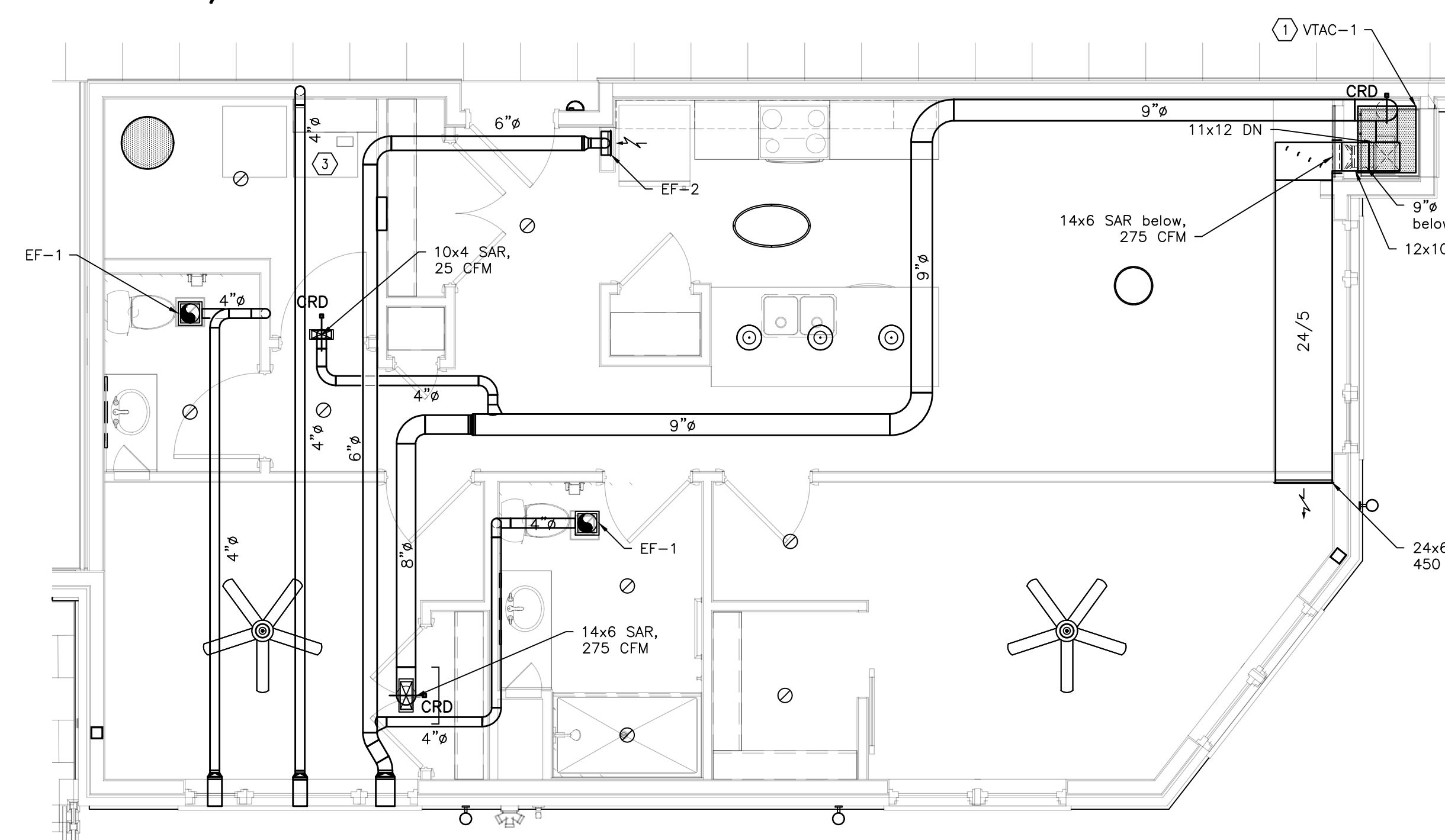

UNIT A - 2BR/1.5BA
1/4"=1'-0"

Coded Notes

- Route condensate drain with trap to condensate drain system. System shall be located against exterior wall. Spill to grade.
- Ductwork routed within dropped ceiling/soffit.
- Provide dryer inlet box and duct of minimum 4" diameter, 0.016" thick metal, smooth interior finish, supported on 4" intervals, run without fire dampers, screens or penetrating fasteners. Install with shield plate(s) if within 1.25" of stud face (as specified) and fire caulk where penetrating wall or ceiling membrane. Do not install within a wall required to be rated. Vertical riser shall include a cleanout, elbow(s) shall be smooth with 10" inside radius, run ductwork in ceiling/joist space above laundry room, and outlet to a louvered shutter on lower floors, 10"x6" SG for top floor. Provide permanent sign showing equivalent duct length and mount within 6" of inlet as directed by AHJ.
- Flush mounted louvered shutter.
- Thermostat mounted 47" A.F.F. at top.
- Dashed line represents required clearance/access to equipment.
- 6" flush mounted louvered shutter.

PERMIT SET

PROJECT DATE: 11.17.2020
PROJECT #: 19187

#	Description	Date
---	-------------	------

MECHANICAL DWELLING UNITS

M.301

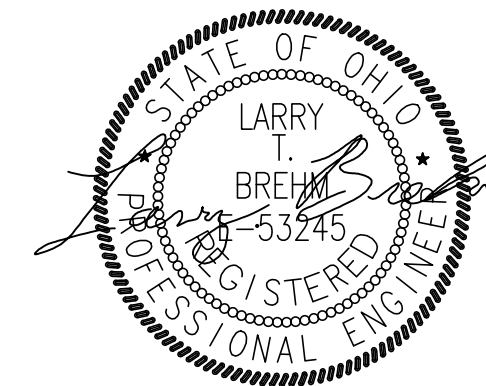

BENNETT POINT

BLDG 1 - 600 E 12TH STREET
BLDG 2 - 528 E 12TH STREET
CINCINNATI, OHIO

© 2021 BY:
BERARDI + PARTNERS, INC.
ARCHITECTS AND ENGINEERS
ALL RIGHTS RESERVED

THE ARRANGEMENTS DEPICTED HEREIN ARE THE SOLE PROPERTY OF BERARDI + PARTNERS, INC. ARCHITECTS AND ENGINEERS, AND MAY NOT BE REPRODUCED WITHOUT ITS WRITTEN PERMISSION.

- NOTE:
1. ALL BIDDERS SHALL VISIT THE SITE AND BECOME FAMILIAR WITH THE EXISTING CONDITIONS AND REQUIREMENTS OF THE PROJECT AND SHALL NOTIFY THE ARCHITECT OF ANY ERRORS AND OMISSIONS SUBSEQUENTLY DISCOVERED IN THE CONTRACT DOCUMENTS.
 2. THE CONTRACT DOCUMENTS ARE COMPRISED OF THE DRAWINGS AND THE PROJECT MANUAL, IN THEIR ENTIRETY. THE INFORMATION IN THESE DOCUMENTS IS DEPENDENT UPON AND COMPLEMENTARY OF EACH OTHER. SEPARATION OF THE CONTRACT DOCUMENTS SHALL NOT BE PERMITTED. IF THE CONTRACTOR CHOOSES TO SEPARATE THE DOCUMENTS, THEY DO SO AT THEIR OWN RISK AND EXPENSE.
 3. ADDITIONALLY SEE GENERAL INFORMATION ON "A0" SHEETS.
 4. THE CLIENT ACKNOWLEDGES THE CONSULTANTS' (ARCHITECT) DRAWINGS AND SPECIFICATIONS AS INSTRUMENTS OF THE CONSULTANTS' (ARCHITECT) PROFESSIONAL SERVICE. THE CLIENT SHALL NOT REUSE OR MAKE OR PERMIT TO BE MADE ANY MODIFICATION TO THE DRAWINGS AND SPECIFICATIONS WITHOUT THE PRIOR WRITTEN AUTHORIZATION OF THE CONSULTANT (ARCHITECT). THE CLIENT AGREES TO WAIVE ANY CLAIM AGAINST THE CONSULTANT (ARCHITECT) ARISING FROM ANY UNAUTHORIZED TRANSFER, REUSE OR MODIFICATION OF THE DRAWINGS AND SPECIFICATIONS.
 5. ARCHITECT CANNOT WARRANT THE ACCURACY OF DATA CONTAINED HEREIN. ANY USE OR REUSE OF ORIGINAL OR ALTERED DESIGN MATERIALS BY THE USER OR OTHER PARTIES WITHOUT THE REVIEW AND WRITTEN APPROVAL OF THE ARCHITECT SHALL BE AT THE SOLE RISK OF THE USER. FURTHERMORE, USER AGREES TO DEFEND, INDEMNIFY, AND HOLD ARCHITECT HARMLESS FROM ALL CLAIMS, INJURIES, DAMAGES, LOSSES, EXPENSES AND ATTORNEY'S FEES ARISING OUT OF THE MODIFICATION OR REUSE OF THESE MATERIALS.
 6. THESE DRAWINGS AS PART OF THE CONTRACT DOCUMENTS ARE DIAGNOSTIC AND ARE NOT INTENDED TO DEFINE EXACT QUANTITIES. LOCATIONS OR CODED REQUIREMENTS. THE DRAWINGS SHALL NOT BE SCALED EXACT. STATE AND LOCAL CODE REQUIREMENTS AND OTHER APPLICABLE CODE REQUIREMENTS SHALL BE VERIFIED BY AND ARE THE SOLE RESPONSIBILITY OF THE CONTRACTOR. ANY INFORMATION WHICH DIRECTLY CONFLICTS WITH ANY OF THESE CODES OR ANY DISCREPANCIES FOUND IN THE CONTRACT DOCUMENTS SHALL BE BROUGHT TO THE ATTENTION OF THE PROJECT ARCHITECT.

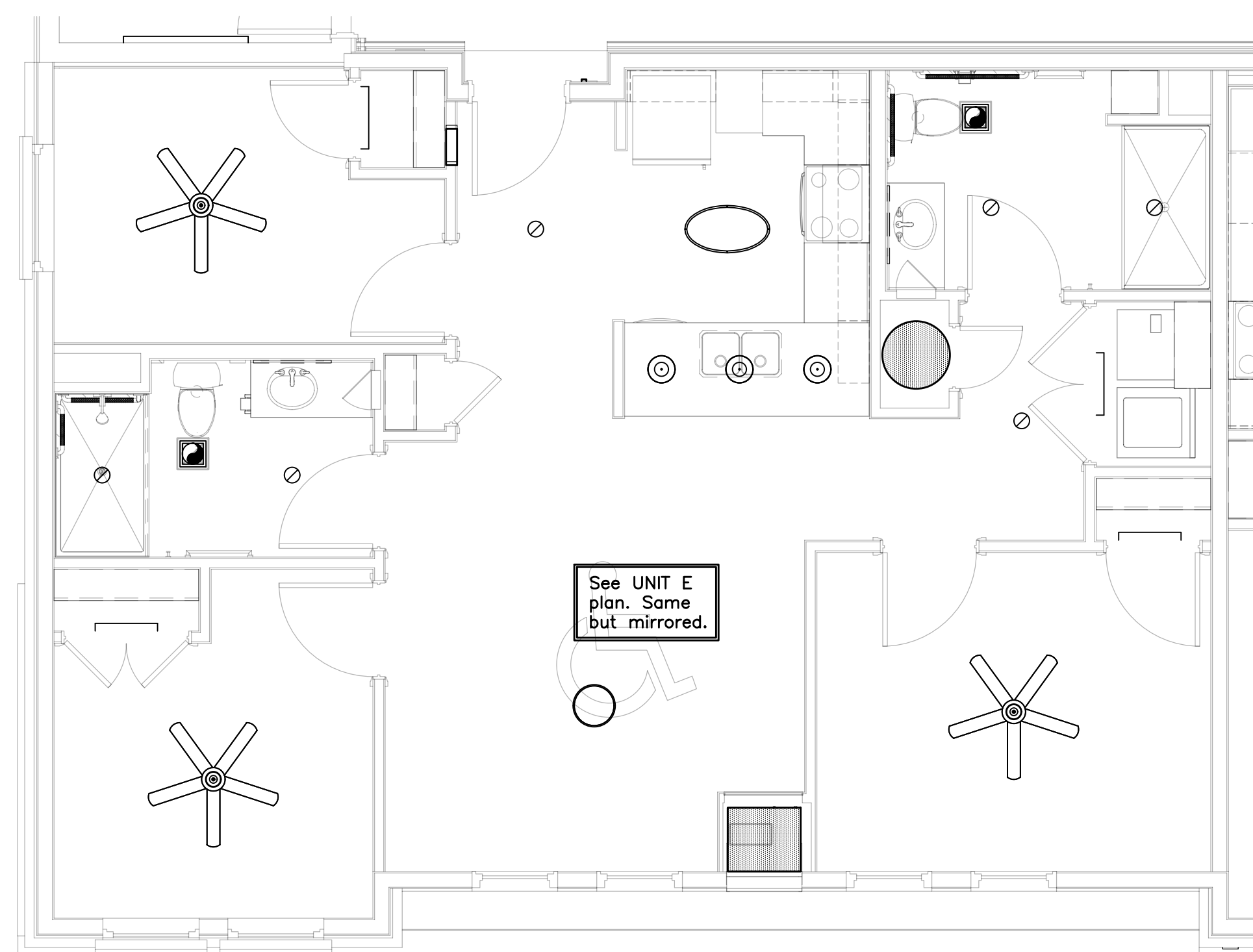

UNIT E-A - 3BR/2BA
1/4"=1'-0"

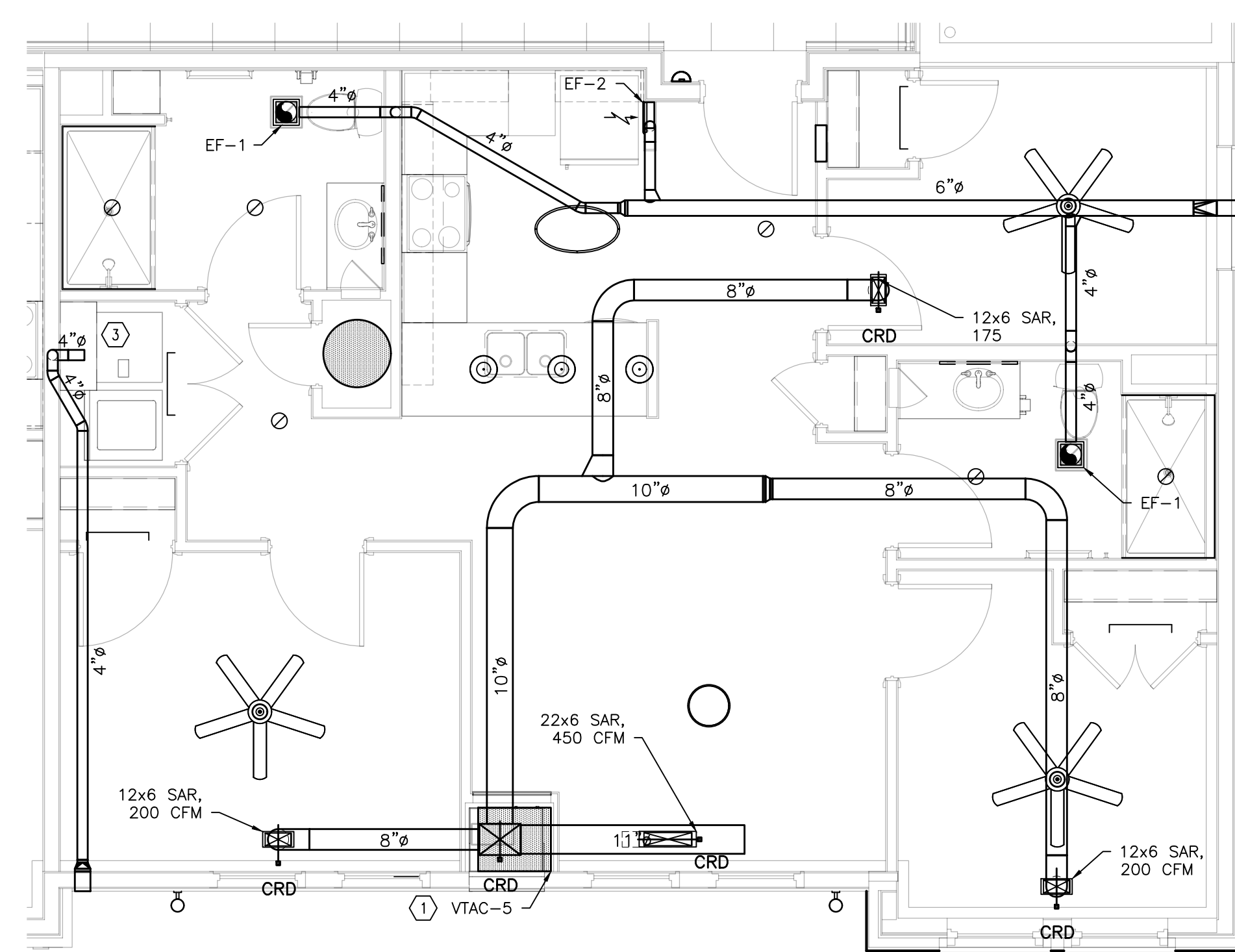

UNIT E - 3BR/2BA
1/4"=1'-0"

Coded Notes

1. Route condensate drain with trap to condensate drain system. System shall be located against exterior wall. Spill to grade.
2. Ductwork routed within dropped ceiling/soffit.
3. Provide dryer inlet box and duct of minimum 4" diameter, 0.016" thick metal, smooth interior finish, supported on 4" intervals, run without fire dampers, screens or penetrating fasteners. Install with shield plate(s) if within 1.25" of stud face (as specified) and fire caulk where penetrating wall or ceiling membrane. Do not install within a wall required to be rated. Vertical riser shall include a cleanout, elbow(s) shall be smooth with 10" inside radius, run ductwork in ceiling/joist space above laundry room, and outlet to a louvered shutter on lower floors, 10"x6" SG for top floor. Provide permanent sign showing equivalent duct length and mount within 6" of inlet as directed by AHJ.
4. Flush mounted louvered shutter.
5. Thermostat mounted 47" A.F.F. at top.
6. Dashed line represents required clearance/access to equipment.
7. 6" flush mounted louvered shutter.

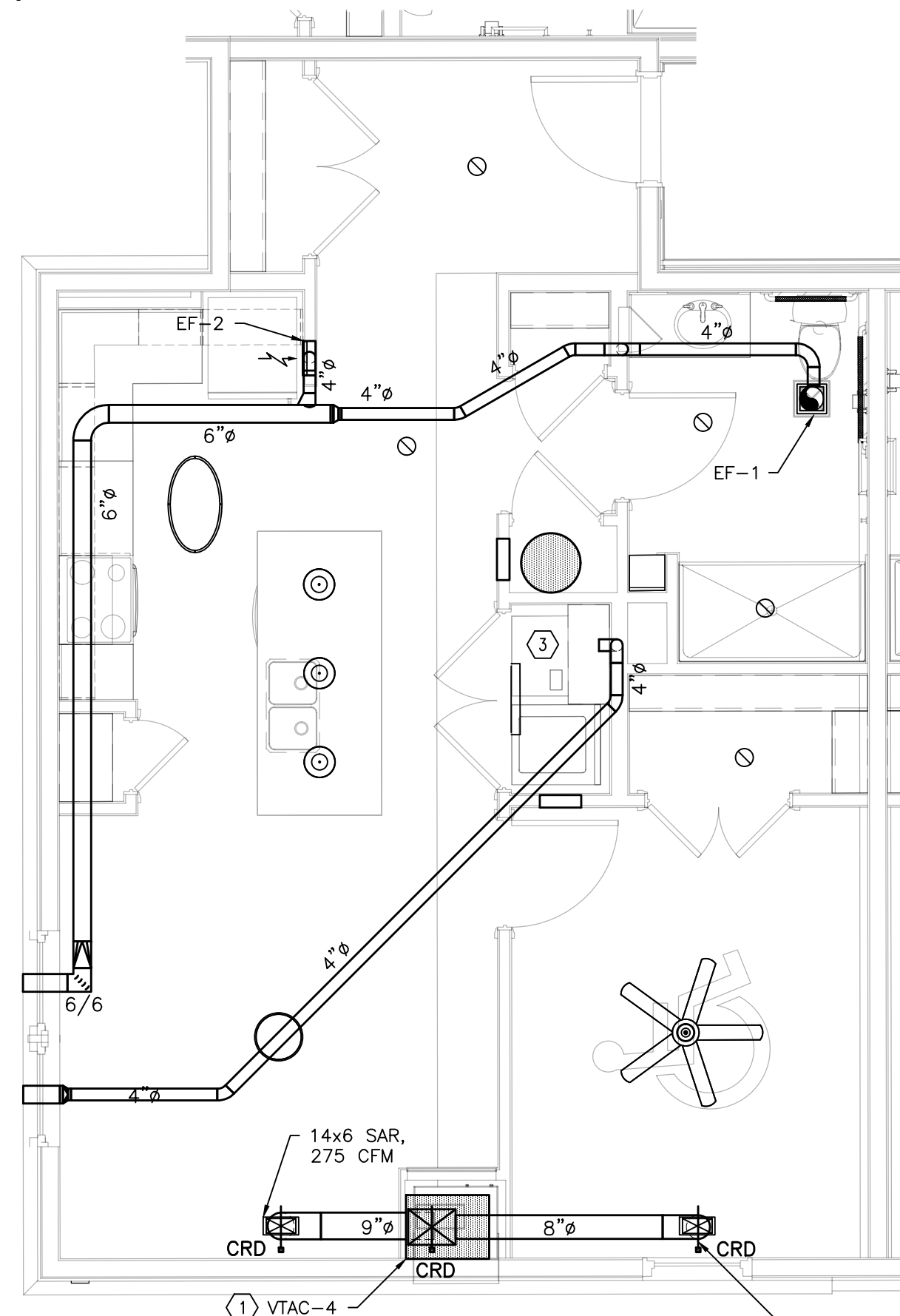

UNIT D-A - 1BR/1BA
1/4"=1'-0"

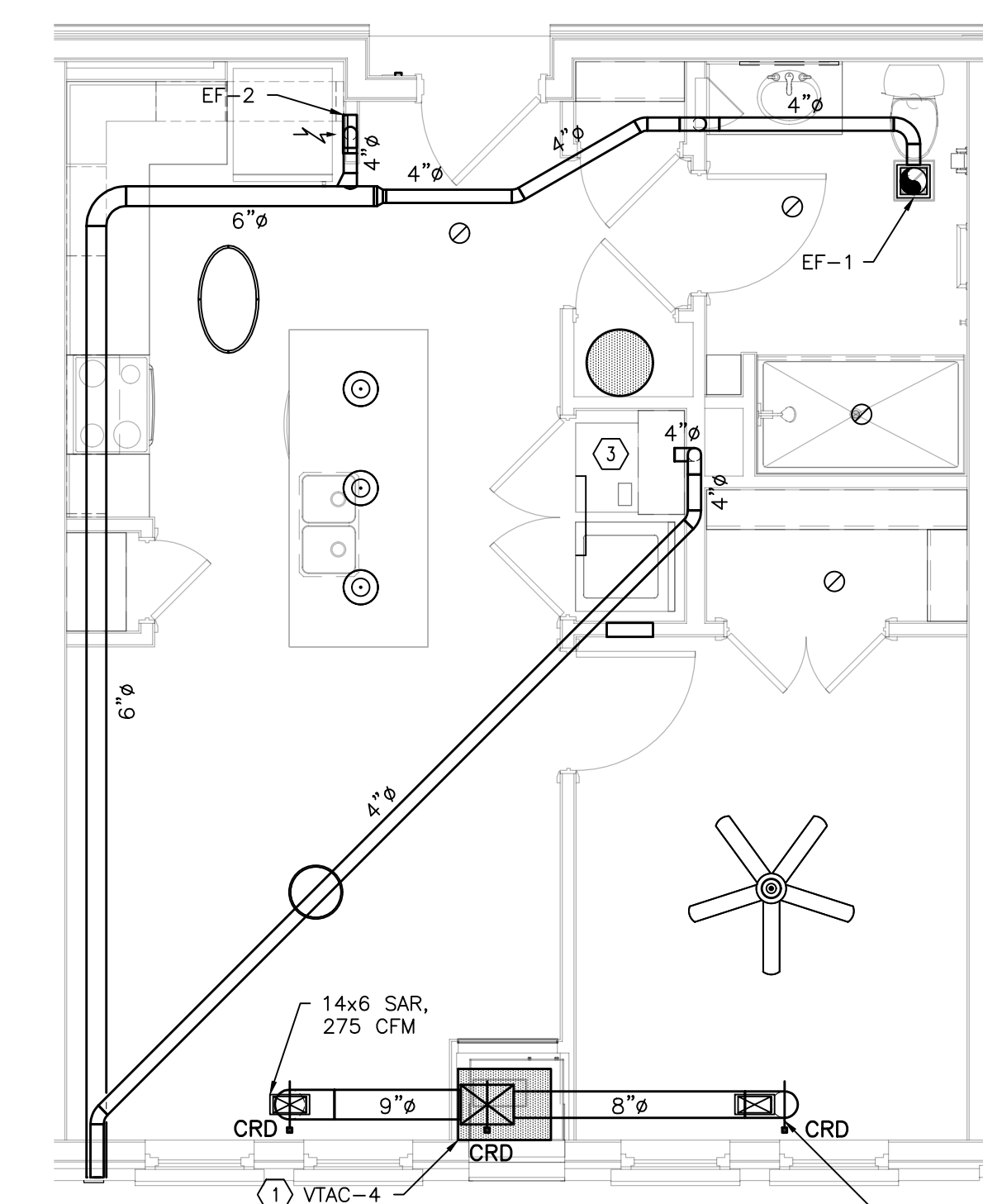

UNIT D - 1BR/1BA
1/4"=1'-0"

PERMIT SET

PROJECT DATE: 11.17.2020
PROJECT #: 19187

#	Description	Date
---	-------------	------

MECHANICAL DWELLING UNITS

M.302

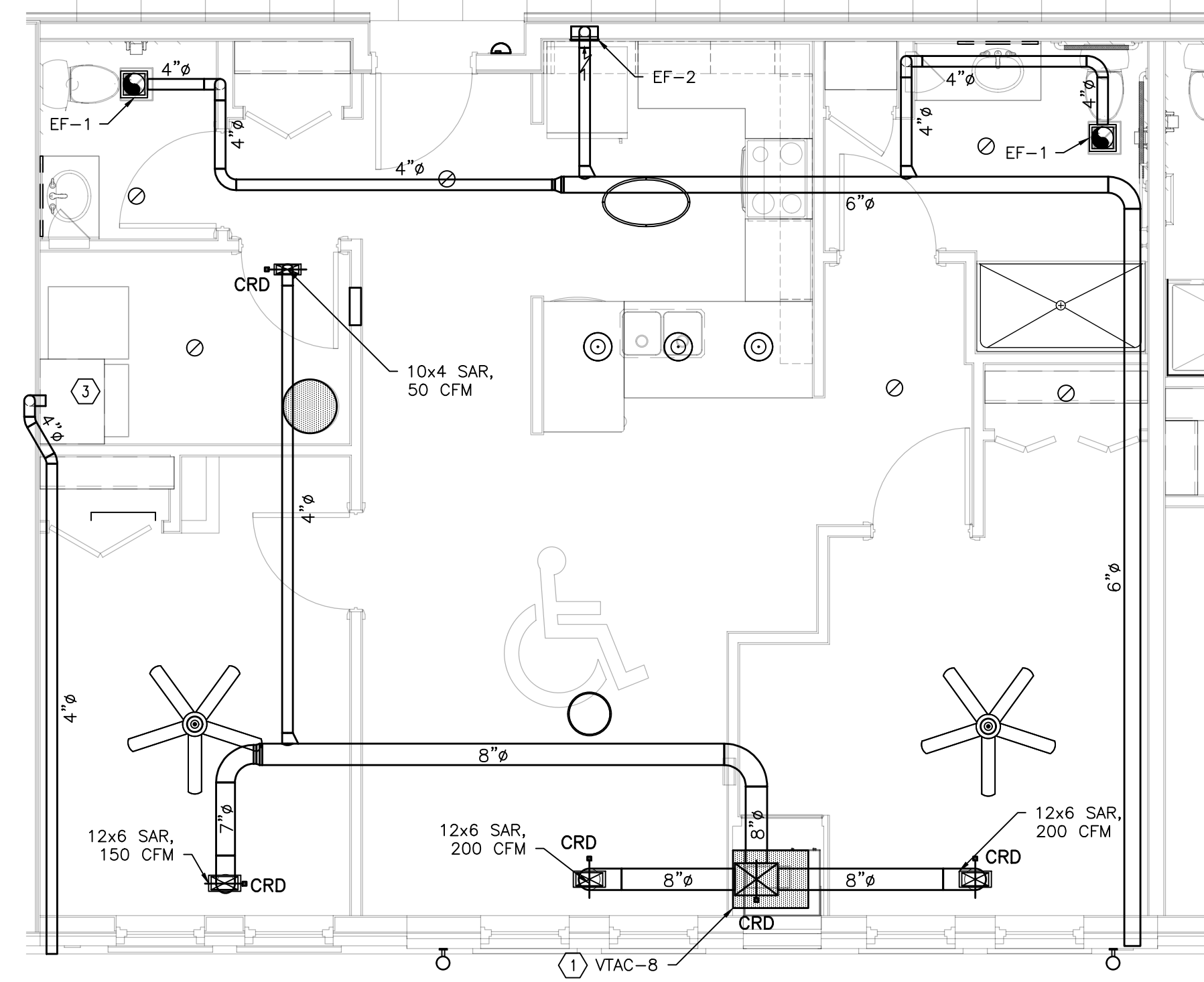

UNIT H-A - 2BR/1.5BA
1/4"=1'-0"

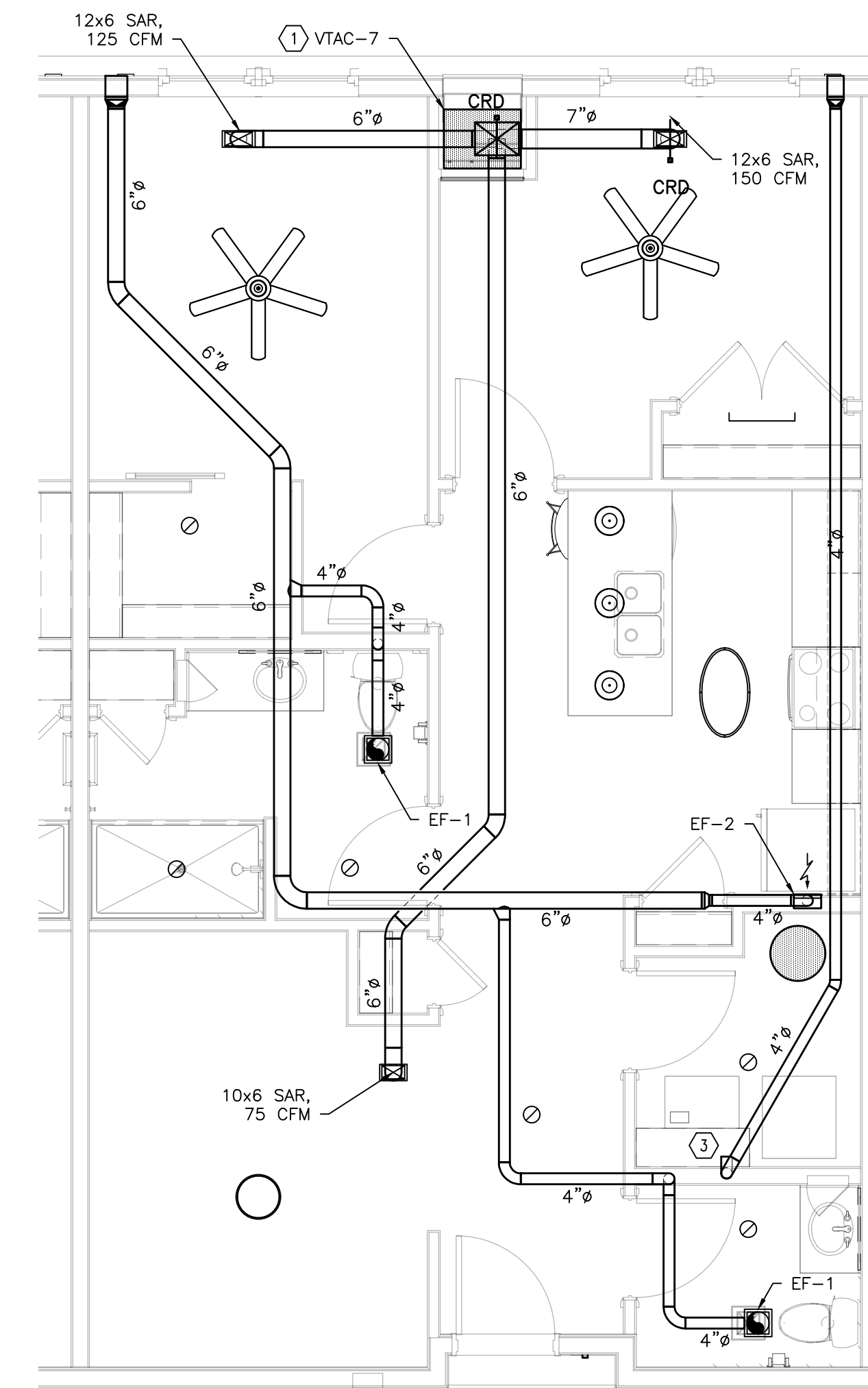

UNIT G - 2BR/1.5BA
1/4"=1'-0"

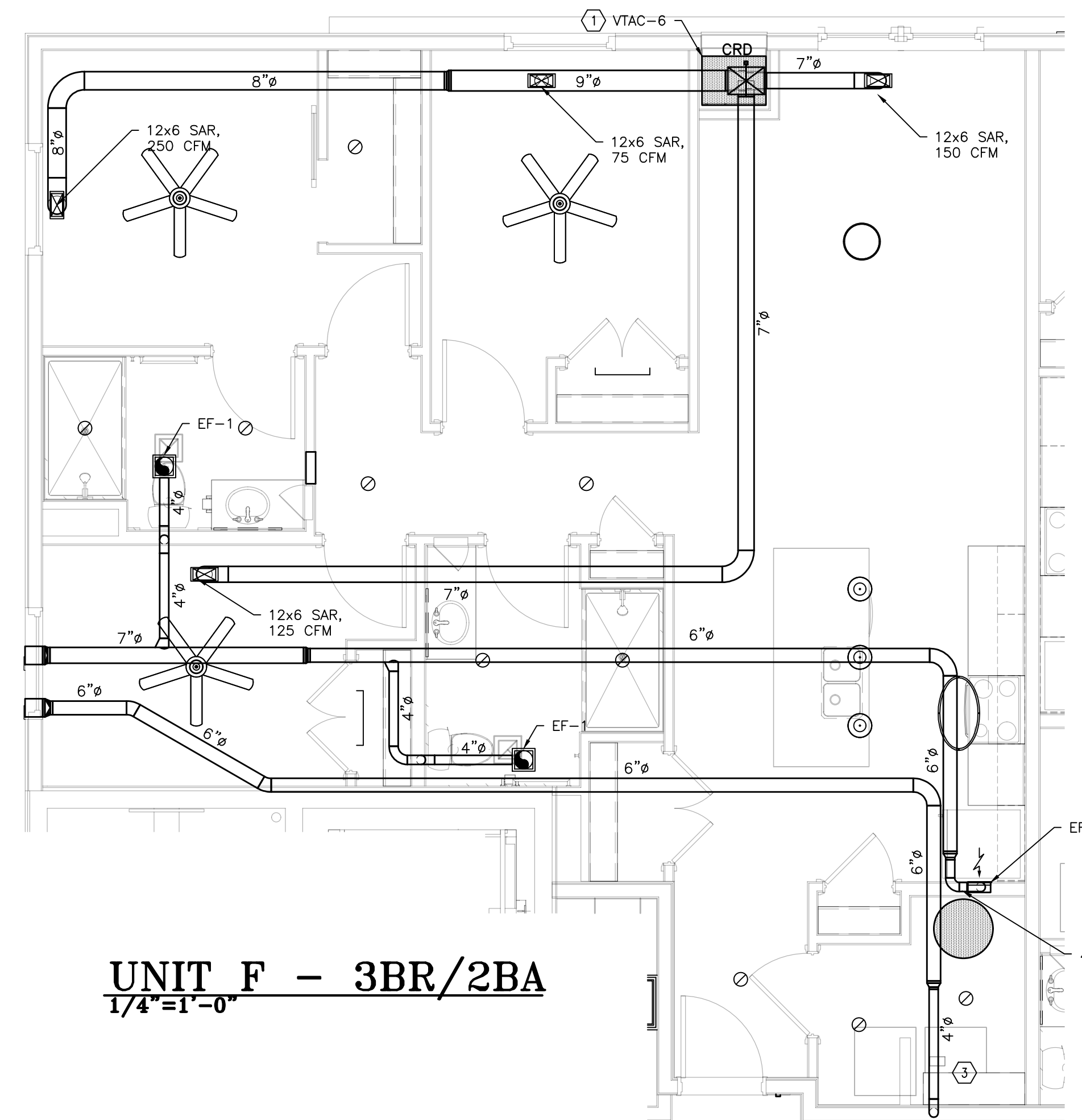

UNIT F - 3BR/2BA
1/4"=1'-0"

Coded Notes

1. Route condensate drain with trap to condensate drain system. System shall be located against exterior wall. Spill to grade.
2. Ductwork routed within dropped ceiling/soffit.
3. Provide dryer inlet box and duct of minimum 4" diameter, 0.016" thick metal, smooth interior finish, supported on 4" intervals, run without fire dampers, screens or penetrating fasteners. Install with shield plate(s) if within 1.25" of stud face (as specified) and fire caulk where penetrating wall or ceiling membrane. Do not install within a wall required to be rated. Vertical riser shall include a cleanout, elbow(s) shall be smooth with 10" inside radius, run ductwork in ceiling/joist space above laundry room, and outlet to a louvered shutter on lower floors, 10"x6" SG for top floor. Provide permanent sign showing equivalent duct length and mount within 6" of inlet as directed by AHJ.
4. Flush mounted louvered shutter.
5. Thermostat mounted 47" A.F.F. at top.
6. Dashed line represents required clearance/access to equipment.
7. 6" flush mounted louvered shutter.

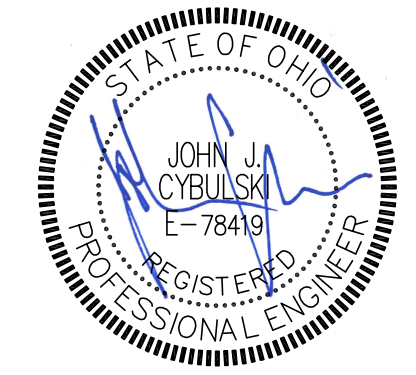

12/1/2022

BENNETT POINT

BLDG 1 - 600 E 12TH STREET
BLDG 2 - 528 E 12TH STREET
CINCINNATI, OHIO

© 2021 BY:
BERARDI + PARTNERS, INC.
ARCHITECTS AND ENGINEERS
ALL RIGHTS RESERVED

THE ARRANGEMENTS DEPICTED HEREIN ARE THE SOLE PROPERTY OF BERARDI + PARTNERS, INC. ARCHITECTS AND ENGINEERS, AND MAY NOT BE REPRODUCED WITHOUT ITS WRITTEN PERMISSION.

- NOTE:
1. ALL BIDDERS SHALL VISIT THE SITE AND BECOME FAMILIAR WITH THE EXISTING CONDITIONS AND REQUIREMENTS OF THE PROJECT AND SHALL NOTIFY THE ARCHITECT OF ANY ERRORS AND OMISSIONS SUBSEQUENTLY DISCOVERED IN THE CONTRACT DOCUMENTS.
 2. THE CONTRACT DOCUMENTS ARE COMPRISED OF THE DRAWINGS AND THE PROJECT MANUAL, IN THEIR ENTIRETY. THE INFORMATION IN THESE DOCUMENTS IS DEPENDENT UPON AND COMPLEMENTARY TO EACH OTHER. SEPARATION OF THE CONTRACT DOCUMENTS SHALL NOT BE PERMITTED. IF THE CONTRACTOR CHOOSES TO SEPARATE THE DOCUMENTS, THEY DO SO AT THEIR OWN RISK AND EXPENSE.
 3. ADDITIONALLY SEE GENERAL INFORMATION ON "A0" SHEETS.
 4. THE CLIENT ACKNOWLEDGES THE CONSULTANTS (ARCHITECT) DRAWINGS AND SPECIFICATIONS INCLUDING ALL DOCUMENTS ON ELECTRONIC MEDIA AS INSTRUMENTS OF THE CONSULTANTS (ARCHITECT) PROFESSIONAL SERVICE. THE CLIENT SHALL NOT REUSE OR MAKE OR PERMIT TO BE MADE ANY MODIFICATION TO THE DRAWINGS AND SPECIFICATIONS WITHOUT THE PRIOR WRITTEN AUTHORIZATION OF THE CONSULTANT (ARCHITECT). THE CLIENT AGREES TO WAIVE ANY CLAIM AGAINST THE CONSULTANT (ARCHITECT) ARISING FROM ANY UNAUTHORIZED TRANSFER, REUSE OR MODIFICATION OF THE DRAWINGS AND SPECIFICATIONS.
 5. ARCHITECT CANNOT WARRANT THE ACCURACY OF DATA CONTAINED HEREIN. ANY USE OR REUSE OF ORIGINAL OR ALTERED DESIGN MATERIALS BY THE USER OR OTHER PARTIES WITHOUT THE REVIEW AND WRITTEN APPROVAL OF THE ARCHITECT SHALL BE AT THE SOLE RISK OF THE USER. FURTHERMORE, USER AGREES TO DEFEND, INDEMNIFY, AND HOLD ARCHITECT HARMLESS FROM ALL CLAIMS, INJURIES, DAMAGES, LOSSES, EXPENSES AND ATTORNEY'S FEES ARISING OUT OF THE MODIFICATION OR REUSE OF THESE MATERIALS.
 6. THESE DRAWINGS AS PART OF THE CONTRACT DOCUMENTS ARE DIAGNOSTIC AND ARE NOT INTENDED TO DEFINE EXACT QUANTITIES. LOCATIONS OR CODED REQUIREMENTS. THE DRAWINGS SHALL NOT BE SCALED EXACT. STATE AND LOCAL CODE REQUIREMENTS AND OTHER APPLICABLE CODE REQUIREMENTS SHALL BE VERIFIED BY AND ARE THE SOLE RESPONSIBILITY OF THE CONTRACTOR. ANY INFORMATION WHICH DIRECTLY CONFLICTS WITH ANY OF THESE CODES OR ANY DISCREPANCIES FOUND IN THE CONTRACT DOCUMENTS SHALL BE BROUGHT TO THE ATTENTION OF THE PROJECT ARCHITECT.

PERMIT SET

PROJECT DATE: 11.17.2020
PROJECT #: 19187

#	Description	Date
---	-------------	------

MECHANICAL DWELLING UNITS

M.303

Air Device Schedule					
Mark	Type	Material	Manufacturer	Model	Remarks
CD-1 CFM	Ceiling Diffuser	Steel	Titus	Omni	4-Way, White, Neck to match duct size, 24"x24" Face, Surface Mount, Border Type 6, Damper
RAR-1	Return Air Register	Steel	Titus	350R	White, Damper
RAR-2	Return Air Register	Steel	Titus	33R	White, Damper, Heavy Duty
RAG-1	Return Air Grille	Steel	Titus	350R	White
RAG-2	Return Air Grille	Steel	Titus	33R	White, Heavy Duty
FRAG	Filter Return Air Grille	Steel	Hart & Cooley	659	White
EAR	Exhaust Air Register	Aluminum	Titus	350F	White, Damper
SG	Soffit Grille	Aluminum	Titus	350F	Mill Finish-prep for Field Point, Insect Screen
SAR-1	Supply Air Register	Steel	Titus	300RS	White, Double Deflection, Damper
TG	Transfer Grille	Steel	Titus	33R	White, Heavy Duty

Vertical Packaged Terminal Heat Pump Schedule													
Mark	CFM	ESP	O.A. CFM	Cooling		EER	Heating @ 47°F		Resist. Heat kW	Voltage	Manuf.	Model	Remarks
				Total MBH	MBH		COP						
VTAC-1	1070	0.3"	66	28.2	11.0	12.3	3.3	5	208V/1φ	Magic-Pak	5MHP4-11-301FP-1	Remote T'STAT, Insulated Sleeve, 24"x16" FRAG, *	
VTAC-2	1070	0.3"	66	28.2	11.0	12.3	3.3	5	208V/1φ	Magic-Pak	5MHP4-11-301FP-1	Remote T'STAT, Insulated Sleeve, 24"x16" FRAG, *	
VTAC-3	525	0.3"	56	12.0	11.0	9.2	3.3	3	208V/1φ	Magic-Pak	3MHP4-11-121FP-1	Remote T'STAT, Insulated Sleeve, 24"x16" FRAG, *	
VTAC-4	525	0.3"	56	12.0	11.0	9.2	3.3	3	208V/1φ	Magic-Pak	3MHP4-11-121FP-1	Remote T'STAT, Insulated Sleeve, 24"x16" FRAG, *	
VTAC-5	1070	0.3"	66	28.2	11.0	12.3	3.3	5	208V/1φ	Magic-Pak	5MHP4-11-301FP-1	Remote T'STAT, Insulated Sleeve, 24"x16" FRAG, *	
VTAC-6	640	0.3"	56	17.0	11.0	9.2	3.3	5	208V/1φ	Magic-Pak	3MHP4-11-181FP-1	Remote T'STAT, Insulated Sleeve, 24"x16" FRAG, *	
VTAC-7	395	0.3"	35	8.6	11.0	9.2	3.3	3	208V/1φ	Magic-Pak	3MHP4-11-091FP-1	Remote T'STAT, Insulated Sleeve, 24"x16" FRAG, *	
VTAC-8	640	0.3"	56	17.0	11.0	9.2	3.3	3	208V/1φ	Magic-Pak	3MHP4-11-181FP-1	Remote T'STAT, Insulated Sleeve, 24"x16" FRAG, *	

* Architectural exterior Louver-Reliable products model #AEL-42 with 194 frame.

Exhaust Fan Schedule									
Mark	CFM	ESP	RPM	HP	Voltage	Manuf.	Model	Remarks	
EF-1	30/80 *	0.30"	---	Frac.	115V/1φ	Broan	ZB80M	BDD, Energy Star, Two Speed	
EF-2	160	0.30"	1,725	Frac.	115V/1φ	Broan	503	BDD, Wall Mount, 5.0 Sones	

* 30 CFM continuous - 80 CFM upon activation of built-in motion sensor, adjust timer to 5 minutes.

Electric Heater Schedule					
Mark	kW	Voltage	Manufacturer	Model	Remarks
EWH-1	1.5	120V/1φ	Q-MARK	AWH-3150F	U.L., B.I. T'STAT, B.I. Disconnect, Tamper Resistant, *
EWH-2	1.5	120V/1φ	Q-MARK	CWH-3150F	U.L., B.I. T'STAT, B.I. Disconnect, *
EUH-1	3.0	208V/1φ	Q-MARK	MUH03-81	U.L., Remote T'STAT, **

* EWH: Mount 8" A.F.F. to bottom, recessed U.N.O. (above wall base, but below signage and railings).
** EUH: Mount top 3" below cgl., 7"-6" A.F.F. min.

Heat Pump Air Handling Unit Schedule												
Mark	CFM	O.A. CFM	ESP	HP	Voltage	Heat kW	MCA	Cooling MBH		Manuf.	Model	Remarks
								Total	Sensible			
AHU-2	400	80	0.3"	Frac.	208V/1φ	5.0	3.0	13.1		Trane	NTXAMT12A112A	W/HP-2, Filters, T'STAT, Louvered access panel, *
AHU-3	875	100	0.3"	Frac.	208V/1φ	0.0	2.73	27.0		Trane	PEAD-A30AA7	W/HP-3, T'STAT
AHU-4	2170	625	0.5"	1.0	208V/1φ	7.5	10.0	55.8		Trane	GAM5B0A60	W/HP-4, Zone Damper System
AHU-7A	450	100	0.14"	Frac.	208V/1φ	-	1.0	11.5		Trane	NTXDKS12A112A	W/HP-7, T'STAT
AHU-7B	450	100	0.14"	Frac.	208V/1φ	-	1.0	11.5		Trane	NTXDKS12A112A	W/HP-7, T'STAT
AHU-7C	450	100	0.14"	Frac.	208V/1φ	-	1.0	11.5		Trane	NTXDKS12A112A	W/HP-7, T'STAT

* Condensate drain auxiliary float shutoff switch.

Ductless Heat Pump Air Handling Unit Schedule									
Mark	CFM	Type	Voltage	Cooling MBH		Heating MBH	Manuf.	Model	Remarks
				Total	Sensible				
AHU-1	380	Wall	208V/1φ	12.0	9.7	14.0	Trane	NTXWPH06	W/HP-1, T'STAT #MHK1, *

* Factory condensate pump #Blue Diamond, condensate drain with in-line check valve.

Heat Pump Condensing Unit Schedule										
Mark	Cooling BTUH	SEER/EER	HSPF	Heat @47°F MBH		Voltage	MCA	Manuf.	Model	Remarks
				Heat @47°F MBH	Heat @17°F MBH					
HP-2	13,100	18.0/12.7	8.5	15.0	9.9	208V/1φ	9.0	Trane	NTXSKS12A112A	W/AHU-2
HP-3	27,000	18.0/12.7	12.6	30.0	22.4	208V/1φ	17.0	Trane	NTXSKS30A112A	W/AHU-3
HP-4	55,858	14.5/12.0	8.5	53.5	36.0	208V/1φ	32.5	Trane	4TWR5060	W/AHU-4
HP-7	36,000	17.5/12.7	10.7	45.0	36.0	208V/1φ	42.0	Trane	NTXMPH36A142	W/AHU-7A/B/C

Ductless Heat Pump Condensing Unit Schedule												
Mark	Cooling BTUH	SEER/EER	HSPF	Voltage	Heat @47°F		Heat @17°F		Heat @5°F MBH	Manuf.	Model	Remarks
					MBH	COP	MBH	COP				
HP-1	12,000	20.8/12.0	10.2	208V/1φ	14.0	10.20	9.2	4.31	14.0	Trane	NTXSPH(B)06	W/AHU-1, Low Ambient to OFF

Zone Damper Schedule					
Mark	CFM	Size	Manufacturer	Model	Remarks
ZD-1	170	8"	Trane	VADB08	Thermostat, With AHU-4, *
ZD-2	620	8"x12"	Trane	VARA5R	Thermostat, With AHU-4, *
ZD-3	900	8"x16"	Trane	VARA7R	Thermostat, With AHU-4, *
ZD-4	100	6"	Trane	VADB06	Thermostat, With AHU-4, *
ZD-5	60	6"	Trane	VADB06	Thermostat, With AHU-4, *
ZD-6	150	6"	Trane	VADB06	Thermostat, With AHU-4, *

* 24 Volt transformer.

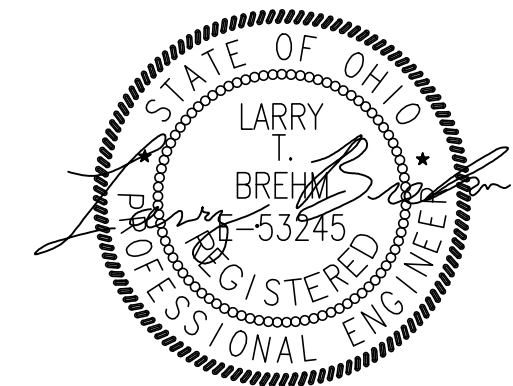

BENNETT POINT

BLDG 1 - 600 E 12TH STREET
BLDG 2 - 528 E 12TH STREET
CINCINNATI, OHIO

© 2021 BY:
BERARDI + PARTNERS, INC.
ARCHITECTS AND ENGINEERS
ALL RIGHTS RESERVED

THE ARRANGEMENTS DEPICTED HEREIN ARE THE SOLE PROPERTY OF BERARDI + PARTNERS, INC. ARCHITECTS AND ENGINEERS AND MAY NOT BE REPRODUCED WITHOUT ITS WRITTEN PERMISSION.

NOTE:
1. ALL BIDDERS SHALL VISIT THE SITE AND BECOME FAMILIAR WITH THE EXISTING CONDITIONS AND REQUIREMENTS OF THE PROJECT AND SHALL NOTIFY THE ARCHITECT OF ANY ERRORS AND OMISSIONS SUBSEQUENTLY DISCOVERED IN THE CONTRACT DOCUMENTS.
2. THE CONTRACT DOCUMENTS ARE COMPOSED OF THE DRAWINGS AND THE PROJECT MANUAL IN THEIR ENTIRETY. THE INFORMATION IN THESE DOCUMENTS IS DEPENDENT UPON AND COMPLEMENTARY TO EACH OTHER. SEPARATION OF THE CONTRACT DOCUMENTS SHALL NOT BE PERMITTED. IF THE CONTRACTOR CHOOSES TO SEPARATE THE DOCUMENTS, THEY DO SO AT THEIR OWN RISK AND EXPENSE.
3. ADDITIONALLY SEE GENERAL INFORMATION ON "A0" SHEETS.
4. THE CLIENT ACKNOWLEDGES THE CONSULTANT'S (ARCHITECT/PROFESSIONAL SERVICE) INCLUDING ALL DOCUMENTS ON ELECTRONIC MEDIA AS INSTRUMENTS OF SERVICE. THE CLIENT SHALL NOT REUSE OR MAKE OR PERMIT TO BE MADE ANY MODIFICATION TO THE DRAWINGS AND SPECIFICATIONS WITHOUT THE PRIOR WRITTEN AUTHORIZATION OF THE CONSULTANT (ARCHITECT). THE CLIENT AGREES TO WAIVE ANY CLAIM AGAINST THE CONSULTANT (ARCHITECT) ARISING FROM ANY UNAUTHORIZED TRANSFER, REUSE OR MODIFICATION OF THE DRAWINGS AND SPECIFICATIONS.
5. ARCHITECT CANNOT WARRANT THE ACCURACY OF DATA CONTAINED HEREIN. ANY USE OR REUSE OF ORIGINAL OR ALTERED DESIGN MATERIALS BY THE USER OR OTHER PARTIES WITHOUT THE REVIEW AND WRITTEN APPROVAL OF THE ARCHITECT SHALL BE AT THE SOLE RISK OF THE USER. FURTHERMORE, USER AGREES TO DEFEND, INDEMNIFY, AND HOLD ARCHITECT HARMLESS FROM ALL CLAIMS, INJURIES, DAMAGES, LOSSES, EXPENSES AND ATTORNEY'S FEES ARISING OUT OF THE MODIFICATION OR REUSE OF THESE MATERIALS.
6. THESE DRAWINGS AS PART OF THE CONTRACT DOCUMENTS ARE DIAGRAMMATIC AND ARE NOT INTENDED TO DEFINE EXACT QUANTITIES. LOCATIONS OR COORDINATE REQUIREMENTS. THE DRAWINGS SHALL NOT BE SCALED EXACT. STATE AND LOCAL CODE REQUIREMENTS AND OTHER APPLICABLE CODE REQUIREMENTS SHALL BE VERIFIED BY AND ARE THE SOLE RESPONSIBILITY OF THE CONTRACTOR. ANY INFORMATION WHICH DIRECTLY CONFLICTS WITH ANY OF THESE CODES OR ANY DISCREPANCIES FOUND IN THE CONTRACT DOCUMENTS SHALL BE BROUGHT TO THE ATTENTION OF THE PROJECT ARCHITECT.

PERMIT SET

PROJECT DATE: 11.17.2020
PROJECT #: 19187

#	Description	Date
1	Permit Set	03.16.2021

MECHANICAL SCHEDULES

M.401

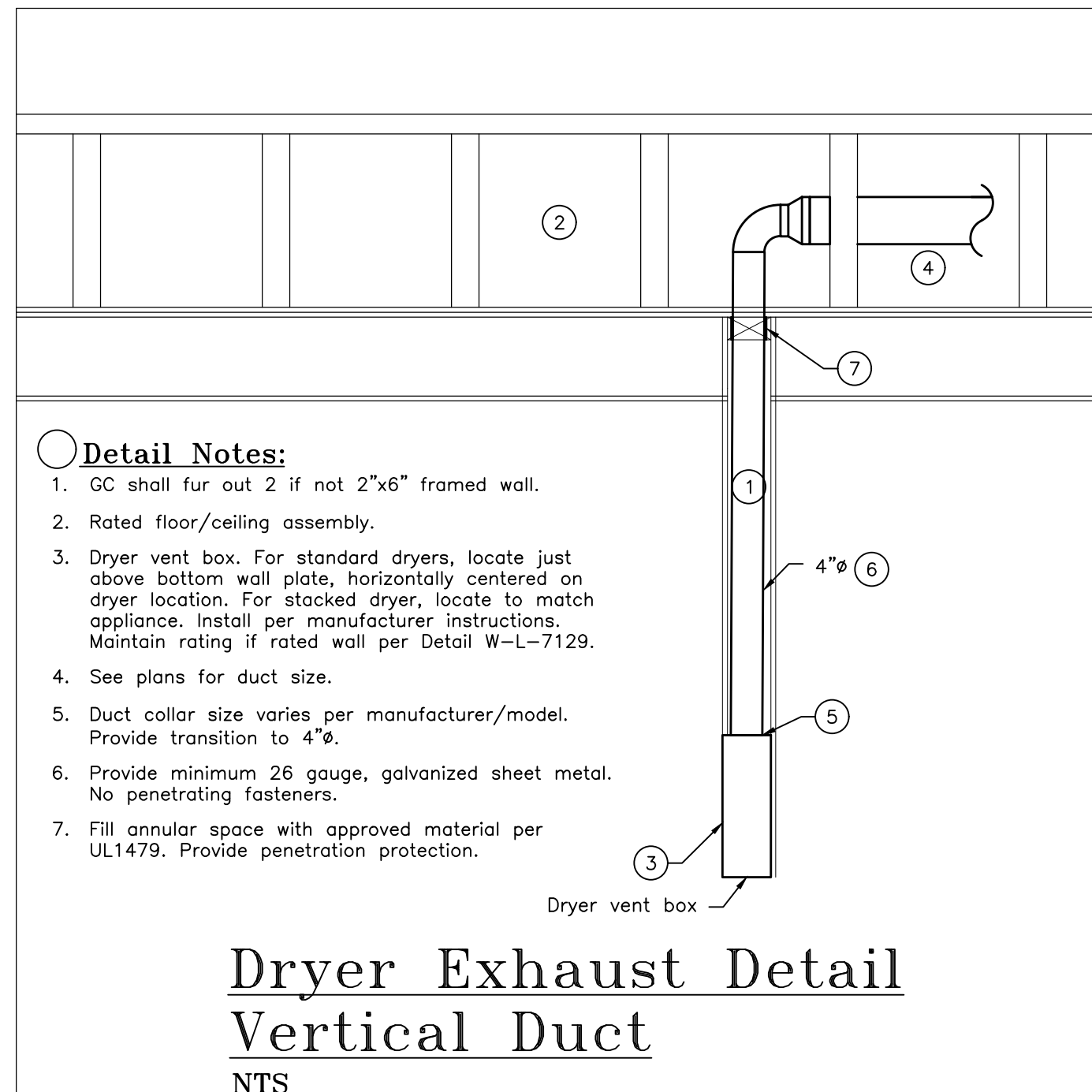

Dryer Exhaust Detail Vertical Duct
NTS

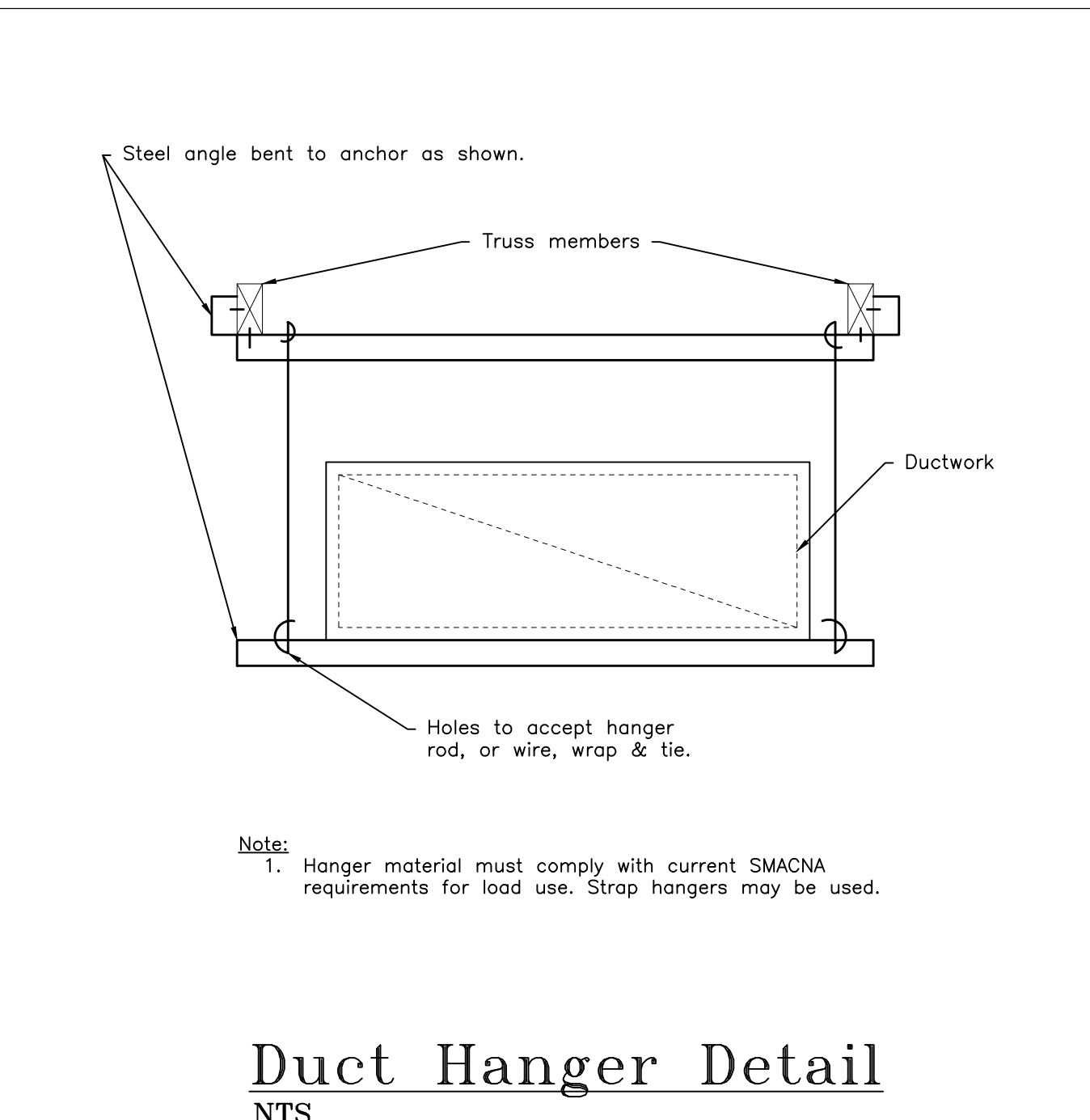

Duct Hanger Detail
NTS

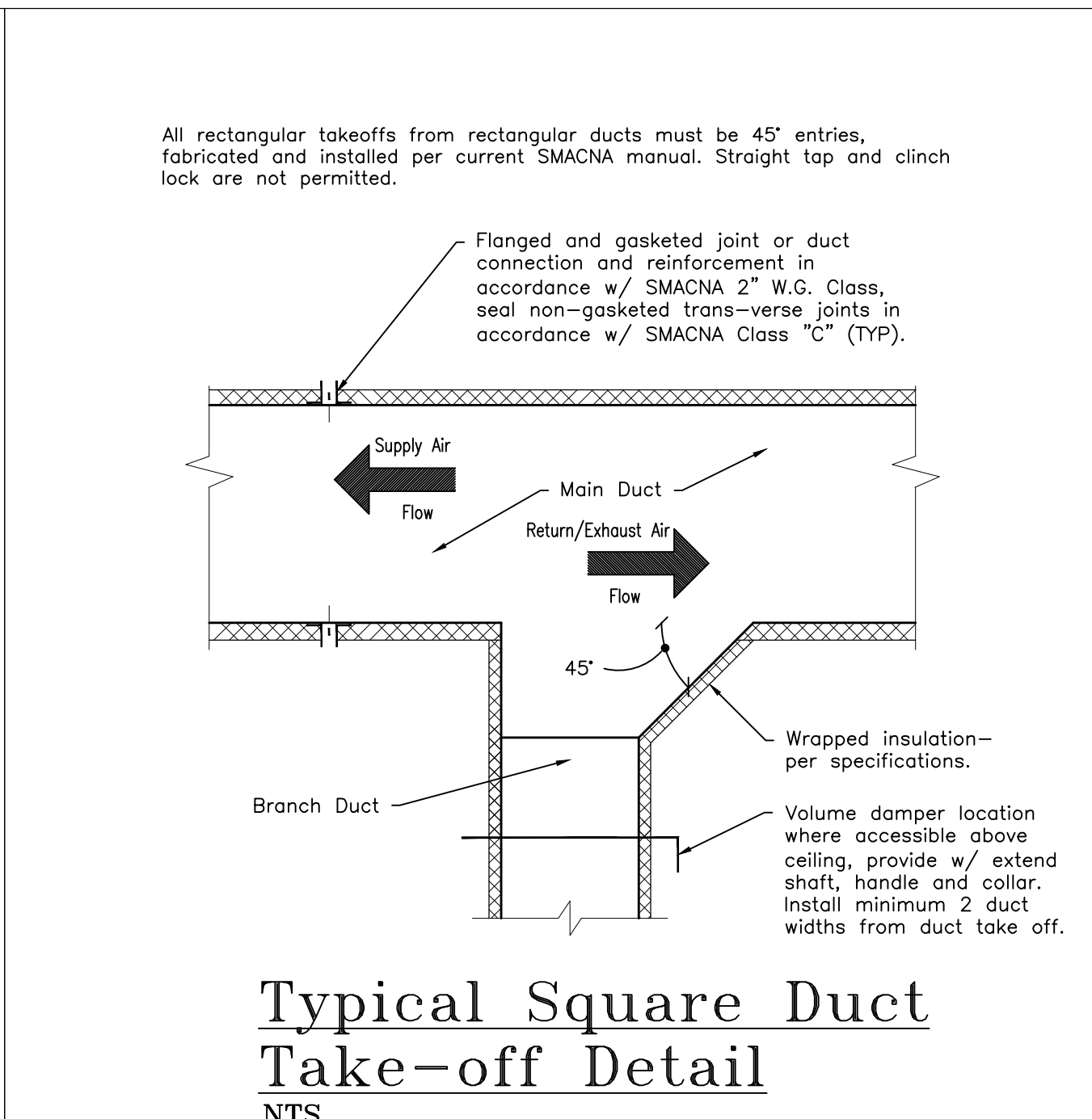

Typical Square Duct Take-off Detail
NTS

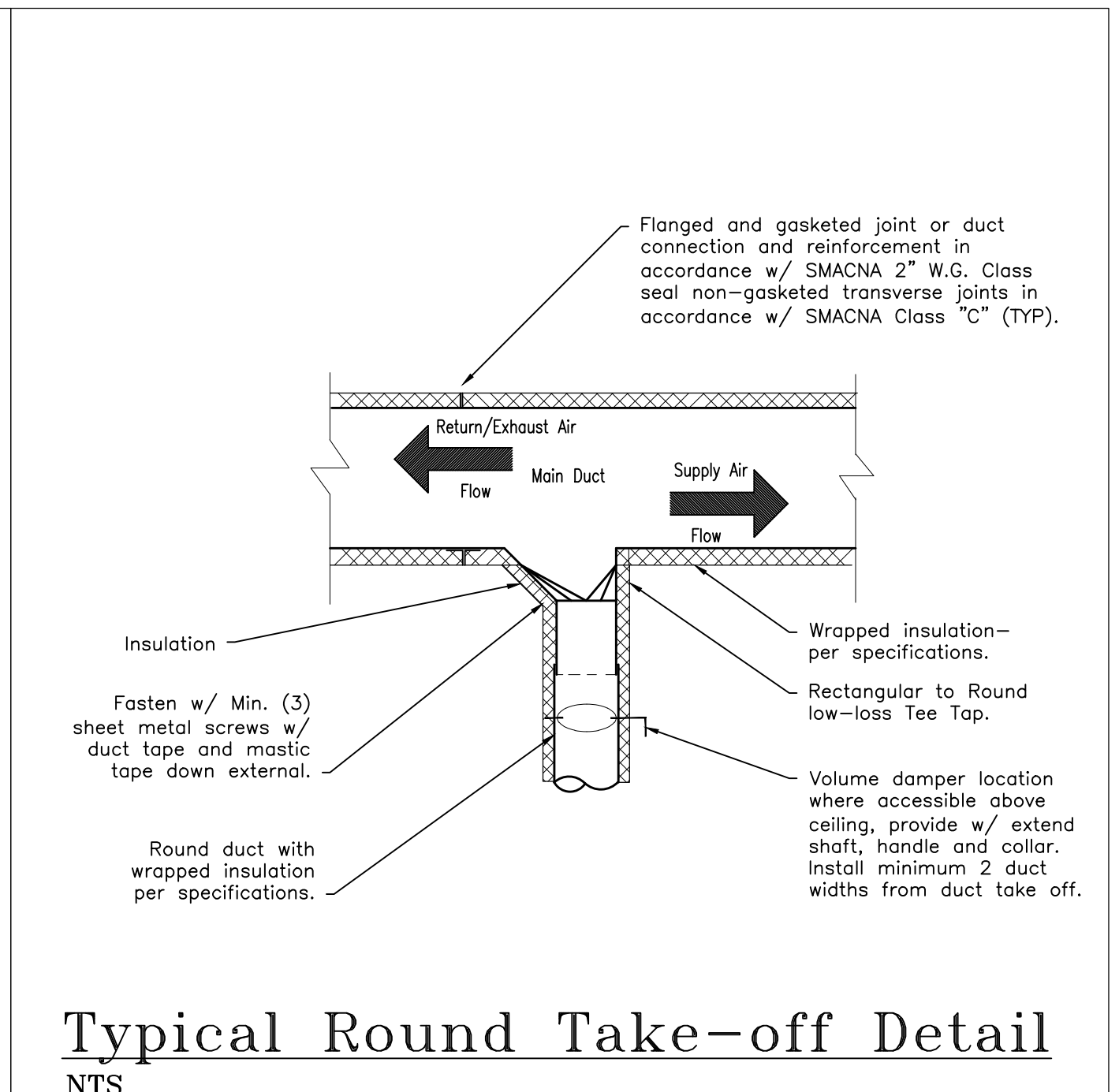

Typical Round Take-off Detail
NTS

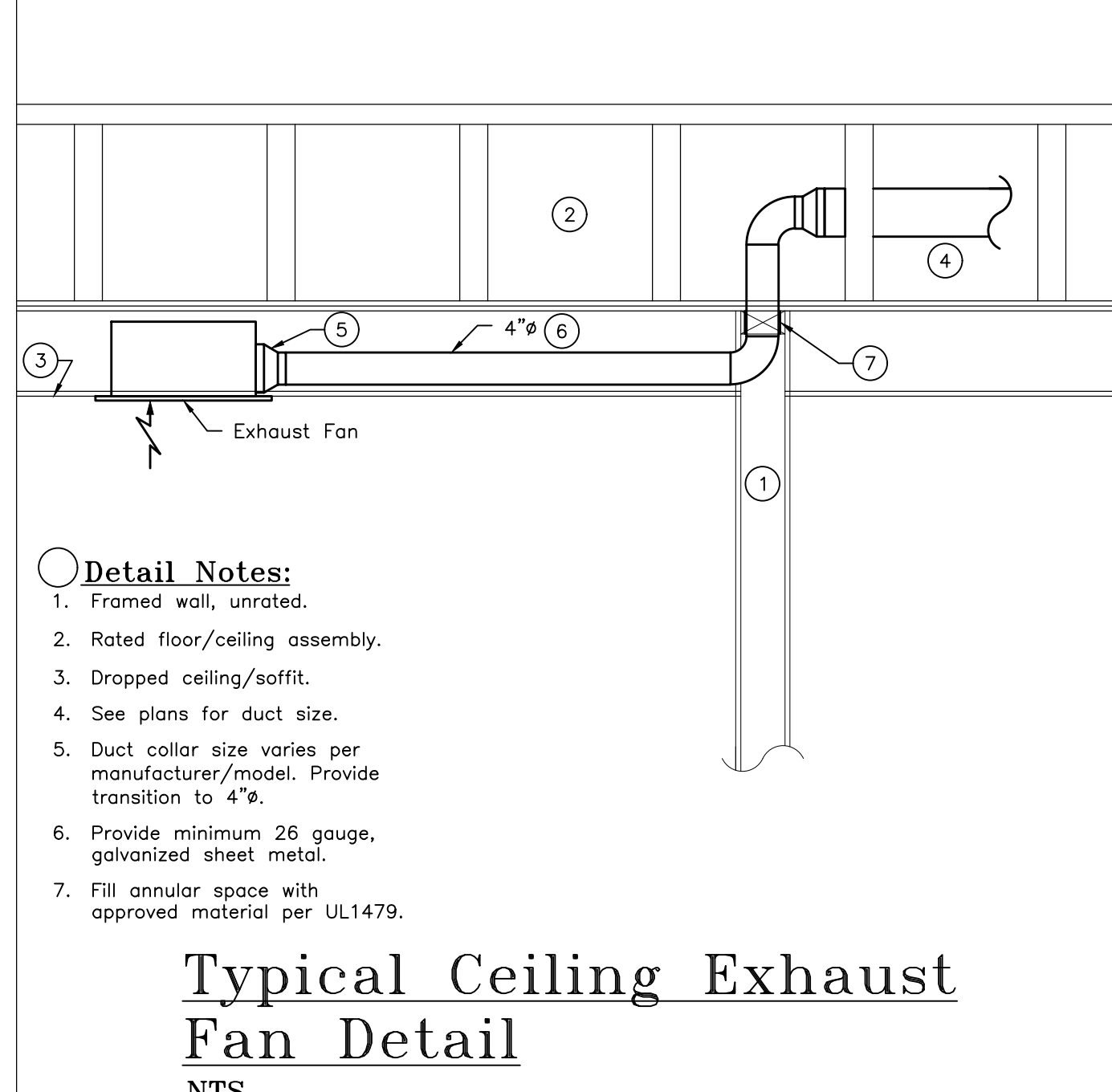

Typical Ceiling Exhaust Fan Detail
NTS

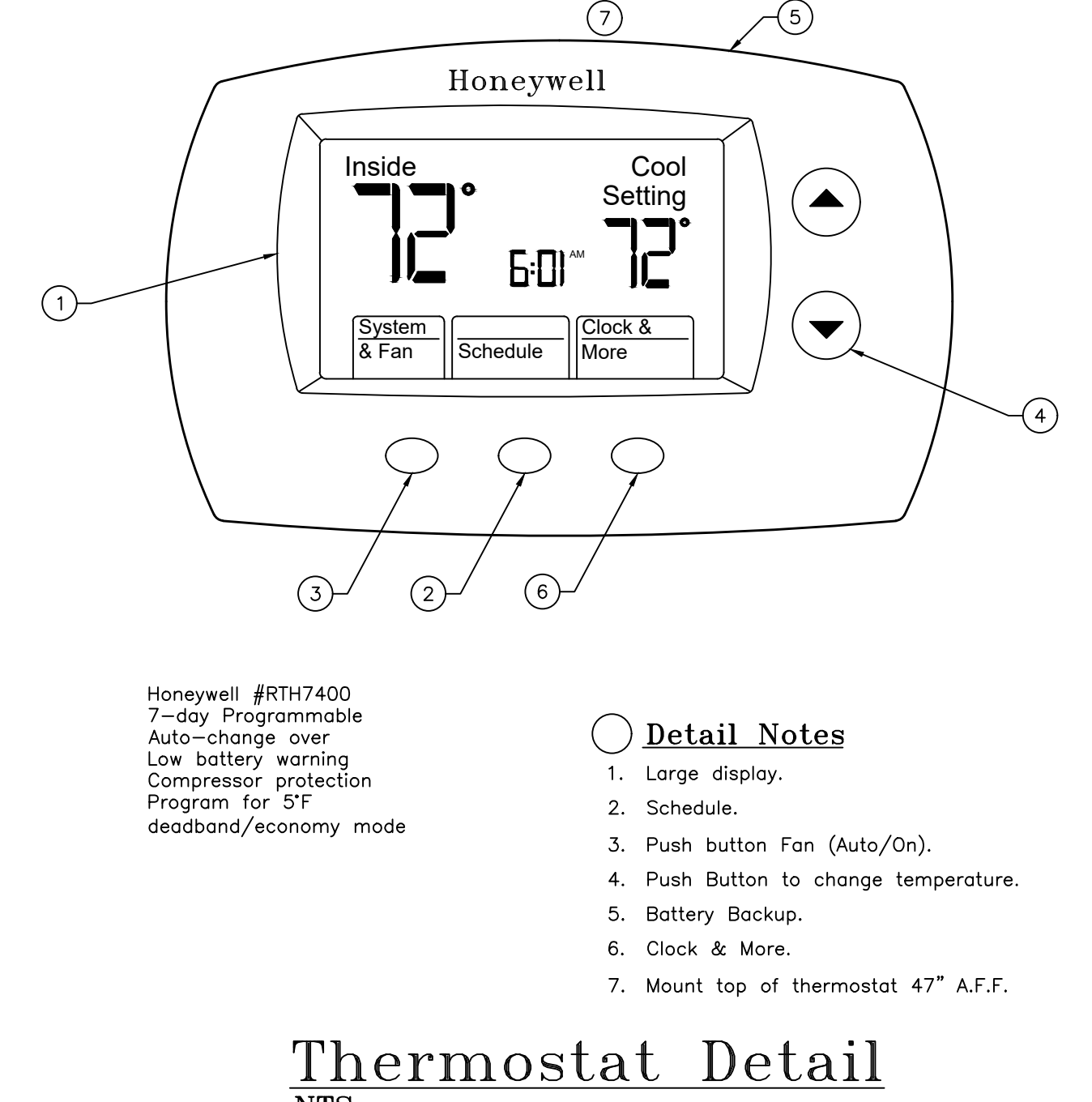

Thermostat Detail
NTS

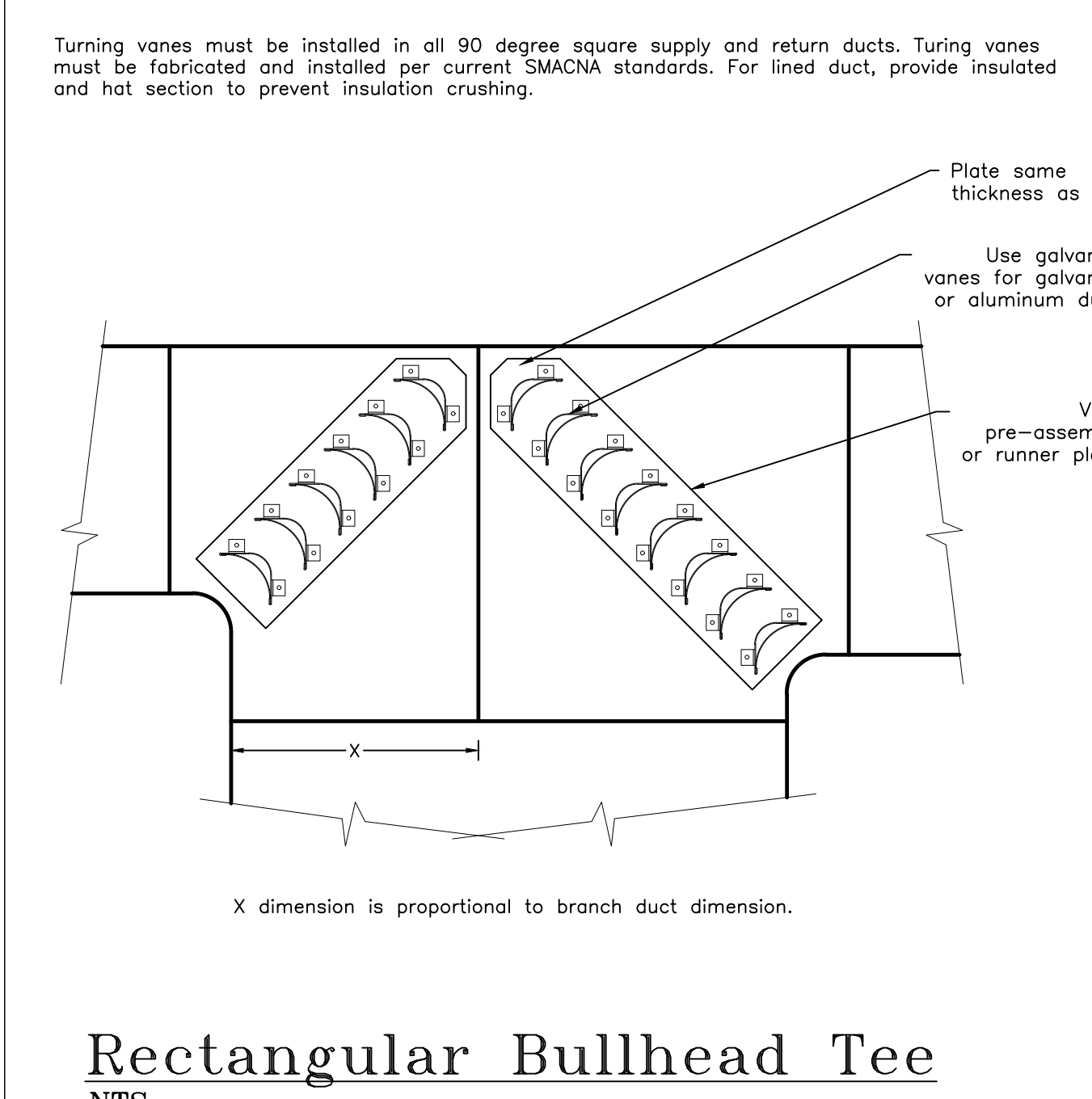

Rectangular Bullhead Tee
NTS

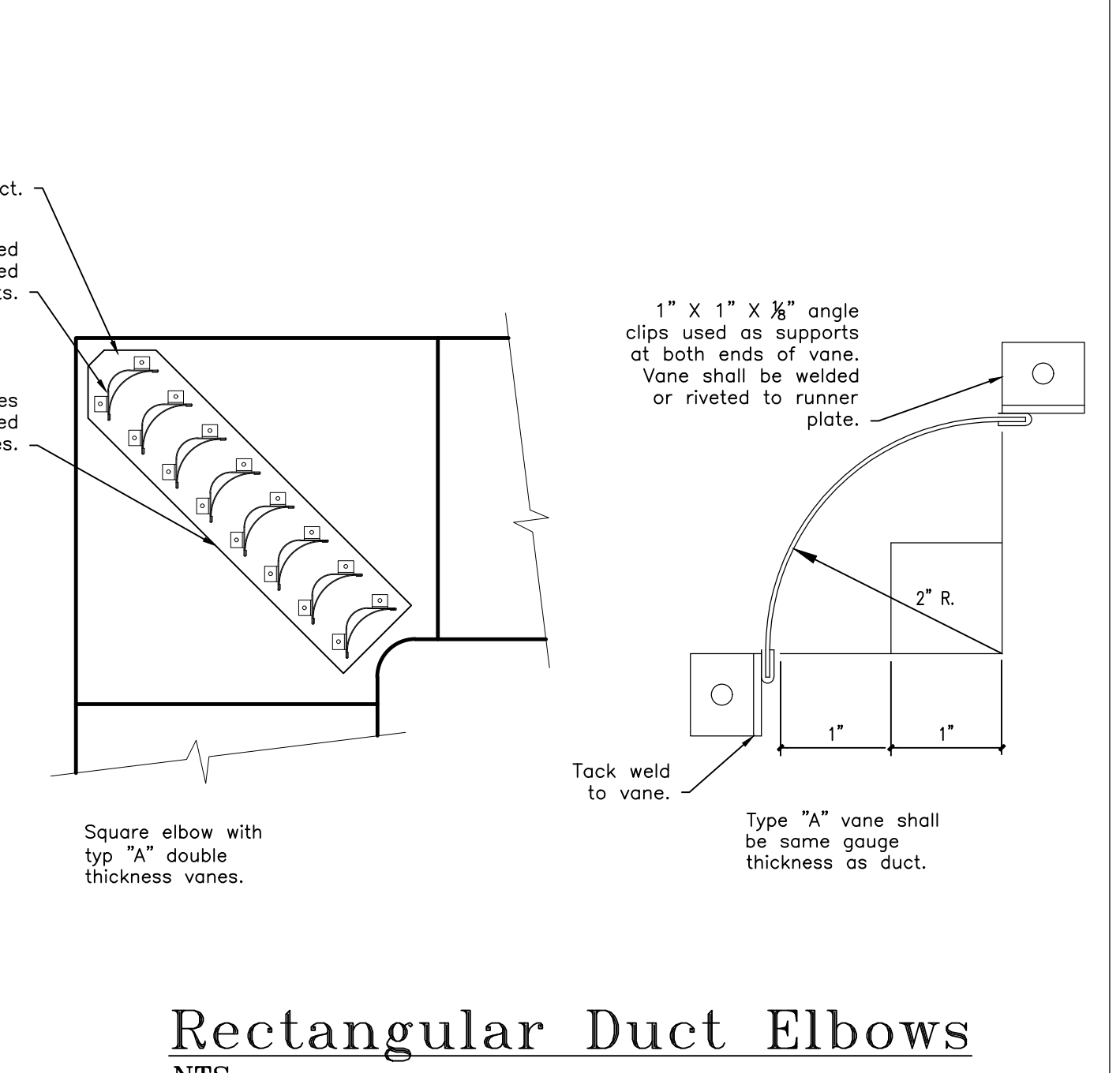

Rectangular Duct Elbows
NTS

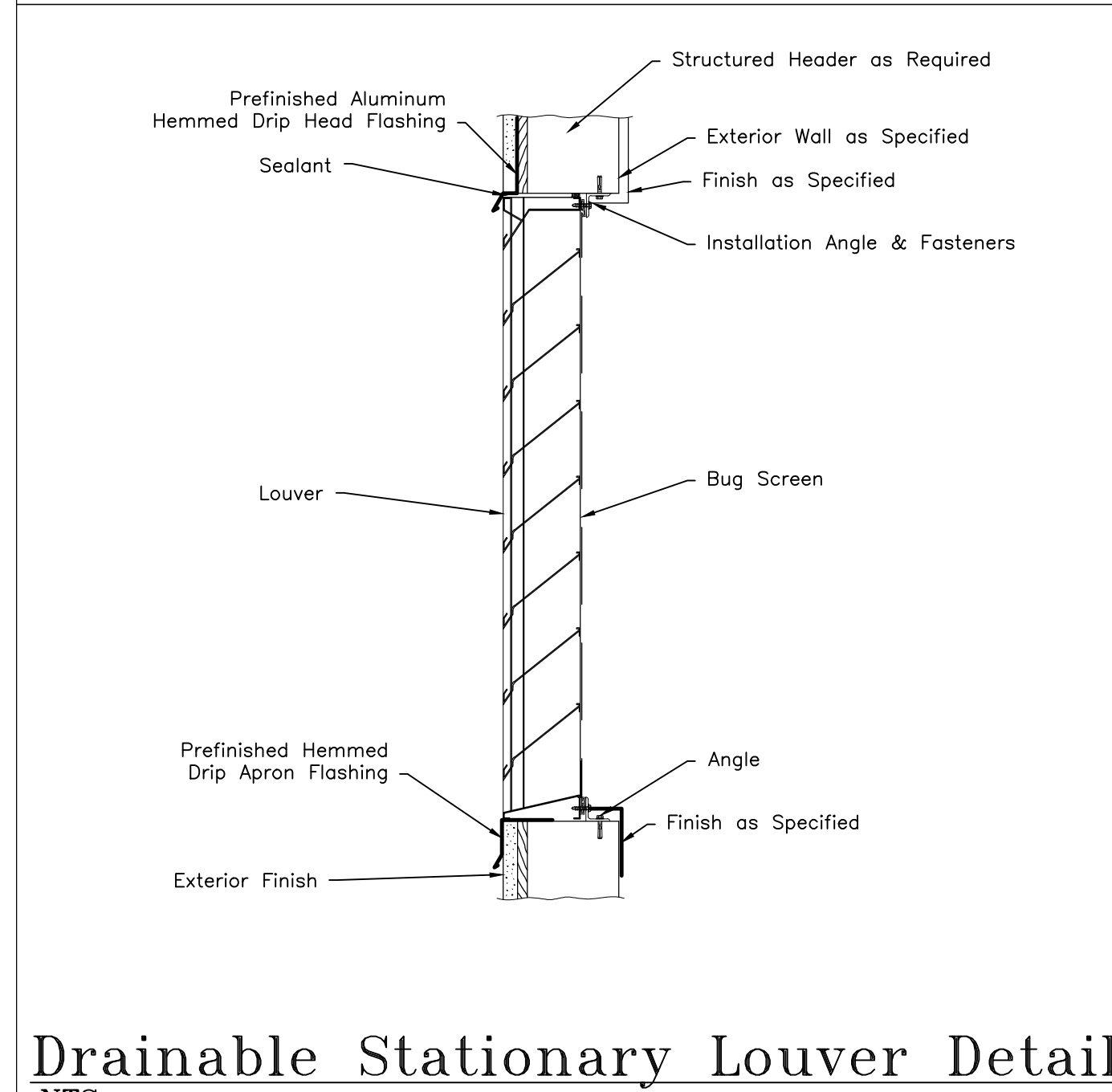

Drainable Stationary Louver Detail
NTS

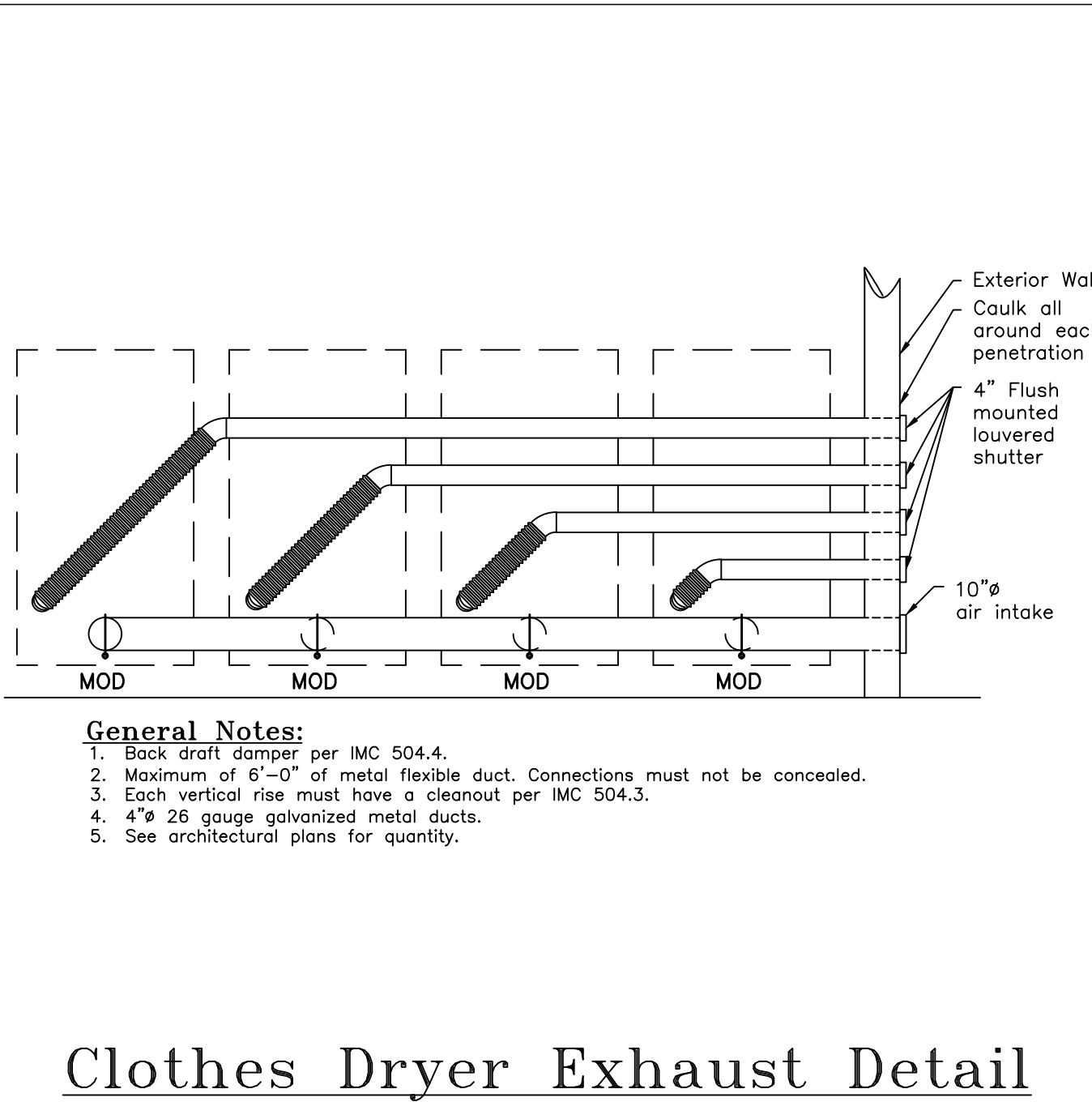

Clothes Dryer Exhaust Detail
NTS

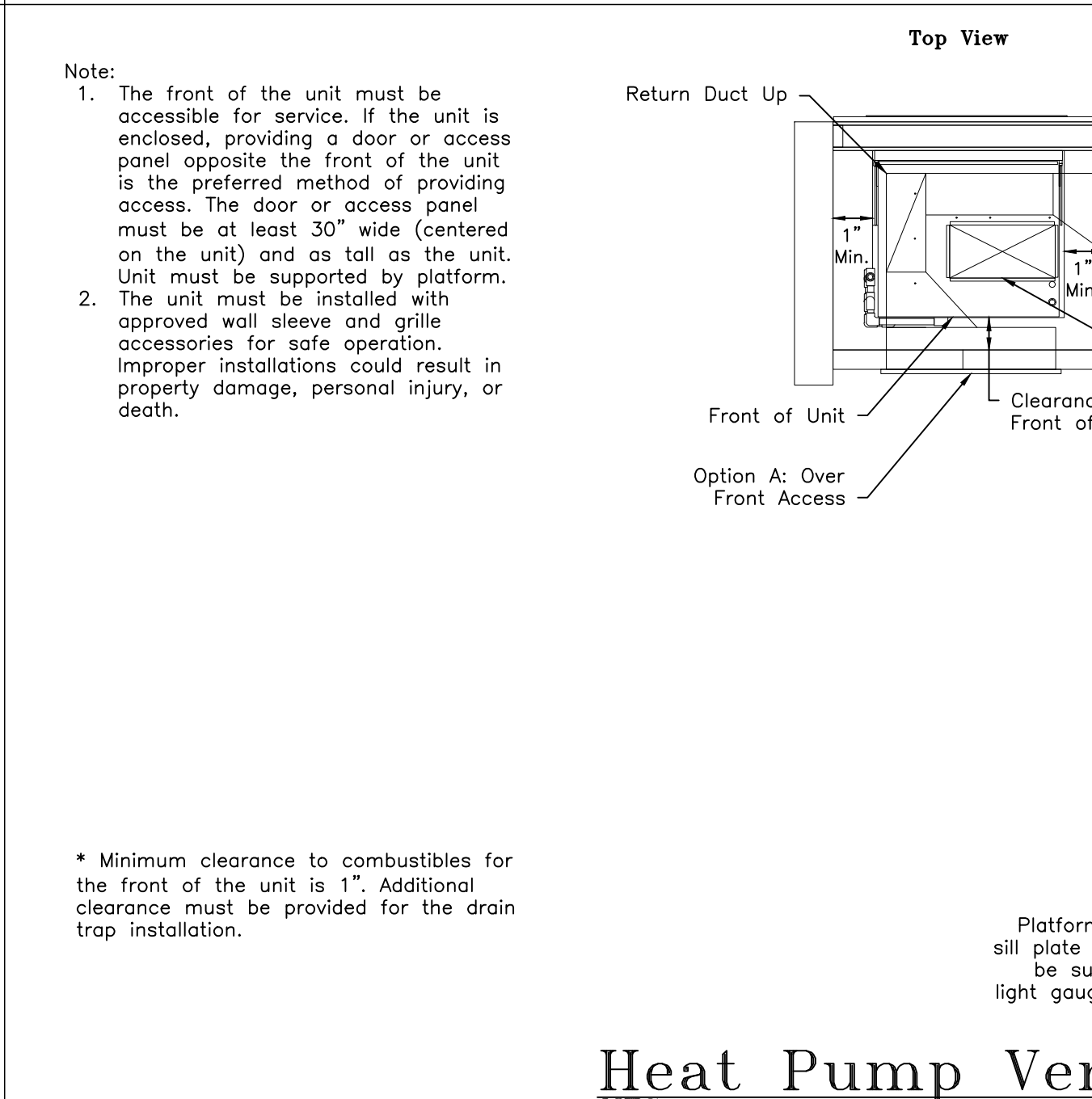

Heat Pump Vertical VTAC Detail
NTS

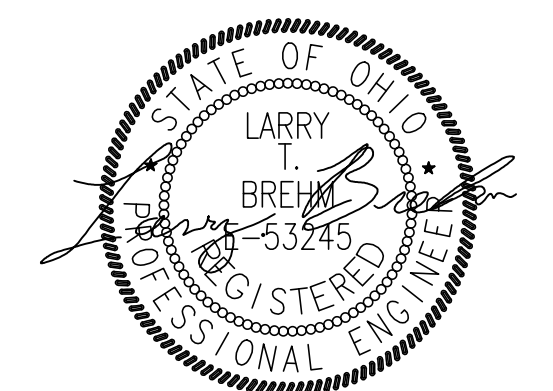

BENNETT POINT
BLDG 1 - 600 E 12TH STREET
BLDG 2 - 528 E 12TH STREET
CINCINNATI, OHIO
© 2021 BY:
BERARDI + PARTNERS, INC.
ARCHITECTS AND ENGINEERS
ALL RIGHTS RESERVED

THE ARRANGEMENTS DEPICTED HEREIN ARE THE SOLE PROPERTY OF BERARDI + PARTNERS, INC., ARCHITECTS AND ENGINEERS, AND MAY NOT BE REPRODUCED WITHOUT ITS WRITTEN PERMISSION.

NOTE:

- ALL BIDDERS SHALL VISIT THE SITE AND BECOME FAMILIAR W/ THE EXISTING CONDITIONS AND REQUIREMENTS OF THE PROJECT AND SHALL NOTIFY THE ARCHITECT OF ANY ERRORS AND OMISSIONS SUBSEQUENTLY DISCOVERED IN THE CONTRACT DOCUMENTS.
- THE CONTRACT DOCUMENTS ARE COMPRISED OF THE DRAWINGS AND THE PROJECT MANUAL. IN THEIR ENTIRETY, THE INFORMATION IN THESE DOCUMENTS IS DEPENDENT UPON AND COMPLEMENTARY TO EACH OTHER. SEPARATION OF THE CONTRACT DOCUMENTS SHALL NOT BE PERMITTED. IF THE CONTRACTOR CHOOSES TO SEPARATE THE DOCUMENTS, THEY DO SO AT THEIR OWN RISK AND EXPENSE.
- ADDITIONALLY SEE GENERAL INFORMATION ON "A0" SHEETS.
- THE CLIENT ACKNOWLEDGES THE CONSULTANT (ARCHITECT) DRAWINGS AND SPECIFICATION INCLUDING ALL DOCUMENTS ON ELECTRONIC MEDIA AS INSTRUMENTS OF THE CONSULTANT (ARCHITECT) PROFESSIONAL SERVICE. THE CLIENT SHALL NOT REUSE OR MAKE OR PERMIT TO BE MADE ANY MODIFICATION TO THE DRAWINGS AND SPECIFICATIONS WITHOUT THE PRIOR WRITTEN AUTHORIZATION OF THE CONSULTANT (ARCHITECT). THE CLIENT AGREES TO WAIVE ANY CLAIM AGAINST THE CONSULTANT (ARCHITECT) ARISING FROM ANY UNAUTHORIZED TRANSFER, REUSE OR MODIFICATION OF THE DRAWINGS AND SPECIFICATIONS.
- ARCHITECT CANNOT WARRANT THE ACCURACY OF DATA CONTAINED HEREIN. ANY USE OR REUSE OF ORIGINAL OR ALTERED DESIGN MATERIALS BY THE USER OR OTHER PARTIES WITHOUT THE REVIEW AND WRITTEN APPROVAL OF THE ARCHITECT SHALL BE AT THE SOLE RISK OF THE USER. FURTHERMORE, USER AGREES TO DEFEND, INDEMNIFY, AND HOLD ARCHITECT HARMLESS FROM ALL CLAIMS, INJURIES, DAMAGES, LOSSES, EXPENSES AND ATTORNEY'S FEES ARISING OUT OF THE MODIFICATION OR REUSE OF THESE MATERIALS.
- THESE DRAWINGS AS PART OF THE CONTRACT DOCUMENTS ARE DIAGNOSTIC AND ARE NOT INTENDED TO DEFINE EXACT QUANTITIES. LOCATIONS OR CODED REQUIREMENTS. THE DRAWINGS SHALL NOT BE SCALED EXACT. STATE AND LOCAL CODE REQUIREMENTS AND OTHER APPLICABLE CODE REQUIREMENTS SHALL BE VERIFIED BY AND ARE THE SOLE RESPONSIBILITY OF THE CONTRACTOR. ANY INFORMATION WHICH DIRECTLY CONFLICTS WITH ANY OF THESE CODES OR ANY DISCREPANCIES FOUND IN THE CONTRACT DOCUMENTS SHALL BE BROUGHT TO THE ATTENTION OF THE PROJECT ARCHITECT.

PERMIT SET

PROJECT DATE: 11.17.2020
PROJECT #: 19187

#	Description	Date
1	Permit Set	03.16.2021

MECHANICAL DETAILS

M.402