



**SUBMITTAL**

**RTU-36 PAGE 4  
RTU-1 THRU 31 PAGE 14**

**Project**

FL1B

OFFICE UNITS

**Date**

Monday, August 1, 2025

Jeff Gries  
Habegger Corp,

# Table Of Contents

Project: FL1B  
Prepared By: Jeff Gries

08/01/2025  
02:33PM

<b>RTU HP - 5 Ton</b> .....	<b>3</b>
Unit Report.....	4
Certified Drawing.....	5
Performance Summary.....	9
Unit Feature Sheet.....	12
<b>RTU HP - 25 Ton</b> .....	<b>13</b>
Unit Report.....	14
Certified Drawing.....	15
Performance Summary.....	20
Guide Specifications.....	23
Unit Feature Sheet.....	41
Spec Sheet.....	42

## RTU HP - 5 Ton

Project: FL1B  
Prepared By: Jeff Gries

08/01/2025  
02:33PM

## RTU HP - 5 Ton

**Tag Cover Sheet  
Unit Report  
Certified Drawing  
Performance Report  
Unit Feature Sheet**

## Unit Report For RTU HP - 5 Ton

Project: FL1B  
Prepared By: Jeff Gries

08/01/2025  
02:33PM

Unit Parameters	
<b>RTU-36</b>	
Unit Model:	50FEQA06A2A6-3F0A0
Unit Size:	06 (5 Tons)
Volts-Phase-Hertz:	460-3-60
Heating Type:	Heat Pump
Refrigerant:	R-454B
Heat Control:	One Stage Cooling (04-06)
Duct Cfg:	Vertical Supply / Vertical Return

Dimensions (ft. in.) & Weight (lb.) ***	
Unit Length:	6' 2.375"
Unit Width:	3' 10.625"
Unit Height:	3' 5.375"
<b>Total Operating Weight:</b>	<b>758 lb</b>

\*\*\* Weights and Dimensions are approximate. Weight does not include unit packaging. Approximate dimensions are provided primarily for shipping purposes. For exact dimensions and weights, refer to appropriate product data catalog.

Lines and Filters	
Return Air Filter Type:	Throwaway
Return Air Filter Quantity:	4
Return Air Filter Size:	16 x 16 x 2

Selection includes construction throwaway filter into the base fan curve.

- Unit Configuration**
- Standard/Medium Static - EcoBlue Vane Axial Fan
  - Al/Cu - Al/Cu
  - SystemVu Controller
  - Standard Leak Enthalpy Economizer with Barometric Relief
  - Standard Packaging
  - UL60335-2-40 approved R-454B Dissipation board and leak sensor included as standard

- Warranty Information**
- 5-Year compressor parts (STD.)
  - 5-Year electric heater (STD.)
  - 1-Year parts (STD.)

No optional warranties were selected.

**Ordering Information**

Part Number	Description	Quantity
50FEQA06A2A6-3F0A0	Rooftop Unit	1
	Base Unit	
	SystemVu controller, Low Leak EconoMi\$er2 enthalpy economizer with barometric relief	
<b>Field Installed Accessories</b>		
CRRFCURB001A01	14-inch Tall Roof Curb	1
ZS2P-CAR	ZS Pro	1
CRHEATER337A00	Electric Heater	1
CRSINGLE037A00	Single Point Kit	1

# Certified Drawing for RTU HP - 5 Ton

Project: FL1B  
Prepared By: Jeff Gries

08/01/2025  
02:33PM

- NOTES:
1. DIMENSIONS ARE IN INCHES. DIMENSIONS IN [ ] ARE IN MILLIMETERS.
  2. CENTER OF GRAVITY
  3. DIRECTION OF AIR FLOW
  4. ALL VIEW DRAWN USING 3RD ANGLE

UNIT	J	K
50FEQ04	33 3/8 [847]	18 5/8 [472]
50FEQ05	33 3/8 [847]	14 7/8 [377]
50FEQ06	41 3/8 [1051]	14 7/8 [377]
50FEQ07	41 3/8 [1051]	14 7/8 [377]

THIS DOCUMENT IS THE PROPERTY OF CARRIER CORPORATION AND IS DELIVERED UPON THE EXPRESS CONDITION THAT THE CONTENTS WILL NOT BE DISCLOSED OR USED WITHOUT CARRIER CORPORATION'S WRITTEN CONSENT.

SUBMISSION OF THESE DRAWINGS OR DOCUMENTS DOES NOT CONSTITUTE PART PERFORMANCE OR ACCEPTANCE OF CONTRACT.

CONNECTION SIZES	
A	1 3/8" [35] DIA FIELD POWER SUPPLY HOLE
B	2" [51] DIA POWER SUPPLY KNOCKOUT
C	1 3/4" [44] DIA GAUGE ACCESS PLUG
D	7/8" [22] DIA FIELD CONTROL WIRING HOLE
E	3/4"-14 NPT CONDENSATE DRAIN
G	2 1/2" [64] DIA POWER SUPPLY KNOCK-OUT

THRU-THE-BASE CHART THESE HOLES REQUIRED FOR USE CRBTPWRO08A00, 009A00			
	THREADED CONDUIT SIZE	WIRE USE	REQ'D HOLE SIZES (MAX.)
W	1/2"	115V	7/8" [22.2]
X	1/2"	24V	7/8" [22.2]
Y *	3/4"	POWER	1 1/8" [28.6]
Z **	(009A00) 1/2" FPT	GAS	1 1/8" [28.6]

FOR "THRU-THE-BASEPAN" FACTORY OPTION, FITTINGS FOR ONLY X, Y, & Z ARE PROVIDED

\* SELECT EITHER 3/4" OR 1/2" FOR POWER, DEPENDING ON WIRE SIZE

\*\* (008A00) PROVIDES 3/4" FPT THRU CURB FLANGE & FITTING.

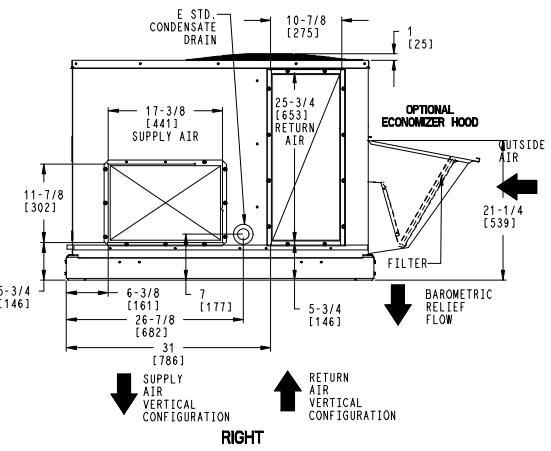
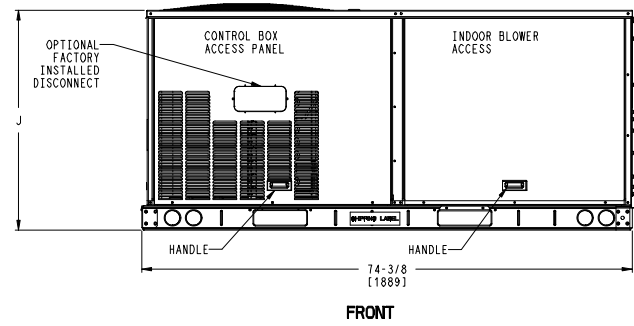
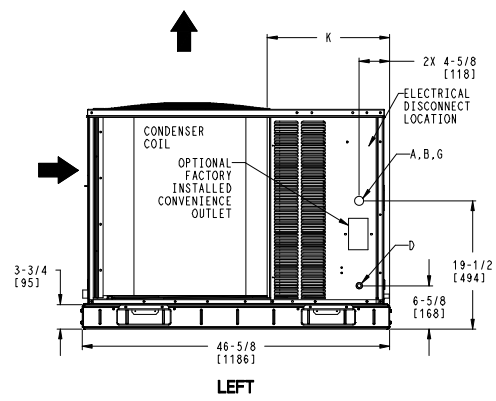
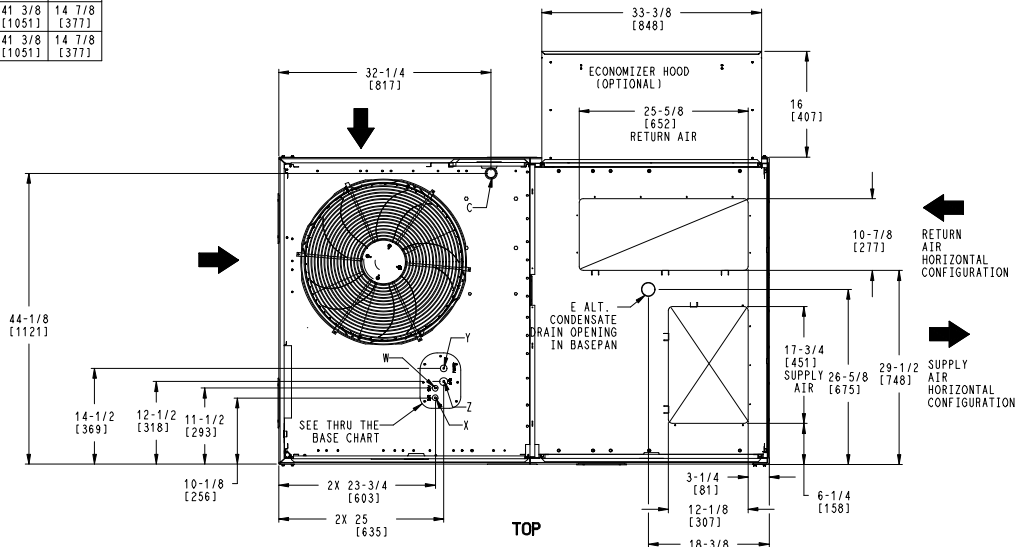

ITC CLASSIFICATION	SHEET	DATE	SUPERCEDES	50FEQ 04-07 SINGLE PACKAGE HEAT PUMP	48TC007000	REV
U.S. ECCN:NSR	1 OF 3	08/30/24	01/17/24			A

# Certified Drawing for RTU HP - 5 Ton

Project: FL1B  
Prepared By: Jeff Gries

08/01/2025  
02:33PM

UNIT	STD. UNIT WEIGHT*		CORNER WEIGHT (A)		CORNER WEIGHT (B)		CORNER WEIGHT (C)		CORNER WEIGHT (D)		C.G.		HEIGHT
	LBS.	KG.	LBS.	KG.	LBS.	KG.	LBS.	KG.	LBS.	KG.	X	Y	
50FEQ*04	476	216	128	58	120	54	110	50	118	54	36 [914]	22 3/8 [568]	16 1/8 [410]
50FEQ*05	473	215	127	58	119	54	110	50	117	53	36 [914]	22 3/8 [568]	16 1/8 [410]
50FEQ*06	584	265	158	72	145	66	134	61	147	67	35 1/2 [902]	22 1/2 [572]	16 1/2 [419]
50FEQ*07	589	267	161	73	146	66	134	61	147	67	35 3/8 [898]	22 5/16 [557]	16 1/2 [419]

\* STANDARD UNIT WEIGHT IS WITHOUT ELECTRIC HEAT AND WITHOUT PACKAGING.  
FOR OTHER OPTIONS AND ACCESSORIES, REFER TO THE PRODUCT DATA CATALOG.

**Carrier**

THIS DOCUMENT IS THE PROPERTY OF CARRIER CORPORATION AND IS DELIVERED UPON THE EXPRESS CONDITION THAT THE CONTENTS WILL NOT BE DISCLOSED OR USED WITHOUT CARRIER CORPORATION'S WRITTEN CONSENT.

SUBMISSION OF THESE DRAWINGS OR DOCUMENTS DOES NOT CONSTITUTE PART PERFORMANCE OR ACCEPTANCE OF CONTRACT.

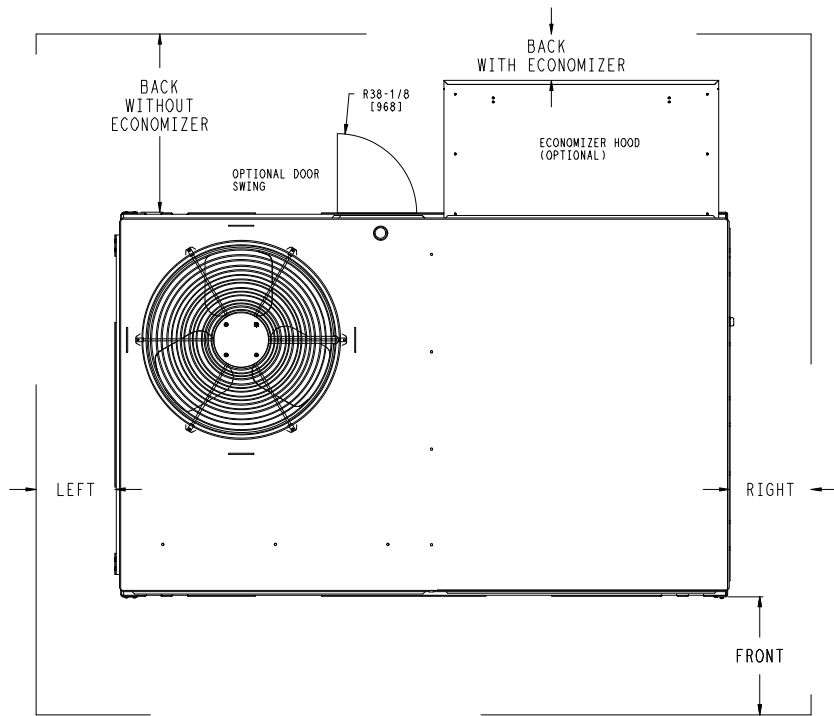
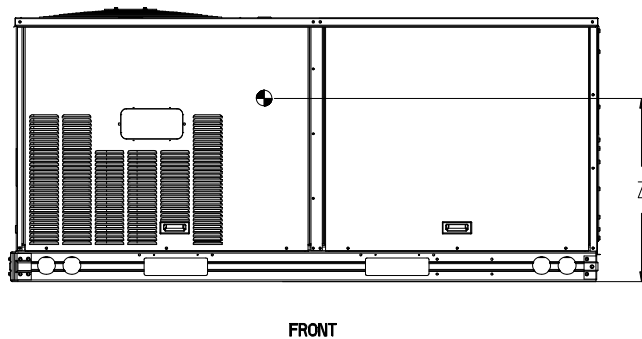
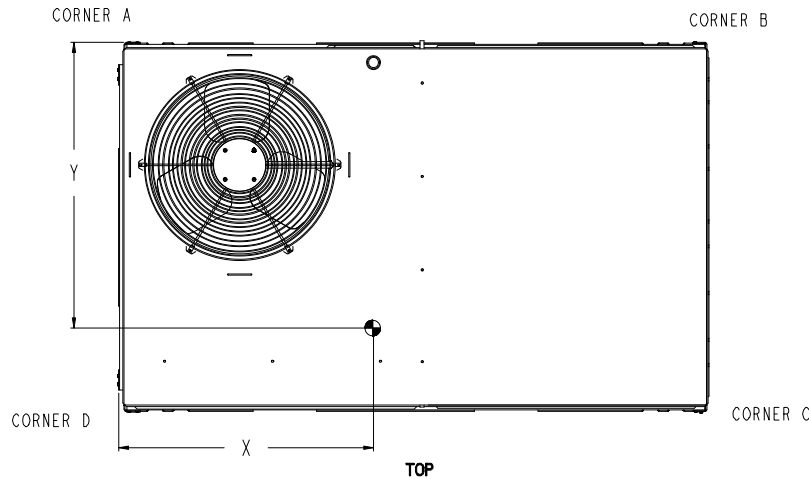

NOTE:

1. FOR ALL MINIMUM CLEARANCES LOCAL CODES OR JURISDICTIONS MAY PREVAIL.

SURFACE	CLEARANCE		OPERATING CLEARANCE
	SERVICE WITH CONDUCTIVE BARRIER	SERVICE WITH NONCONDUCTIVE BARRIER	
FRONT	48 [1219mm]	36 [914mm]	18 [457mm]
LEFT	48 [1219mm]	42 [1067mm]	18 [457mm]
BACK W/O ECON	48 [1219mm]	42 [1067mm]	18 [457mm]
BACK W/ECON	36 [914mm]	36 [914mm]	18 [457mm]
RIGHT	36 [914mm]	36 [914mm]	18 [457mm]
TOP	72 [1829mm]	72 [1829mm]	72 [1829mm]

ITC CLASSIFICATION U.S. ECCN: NSR	SHEET 2 OF 3	DATE 08/30/24	SUPERCEDES 01/17//24	50FEQ 04-07 SINGLE PACKAGE HEAT PUMP	48TC007000	REV A
--------------------------------------	-----------------	------------------	-------------------------	--------------------------------------	------------	----------

# Certified Drawing for RTU HP - 5 Ton

Project: FL1B  
Prepared By: Jeff Gries

08/01/2025  
02:33PM

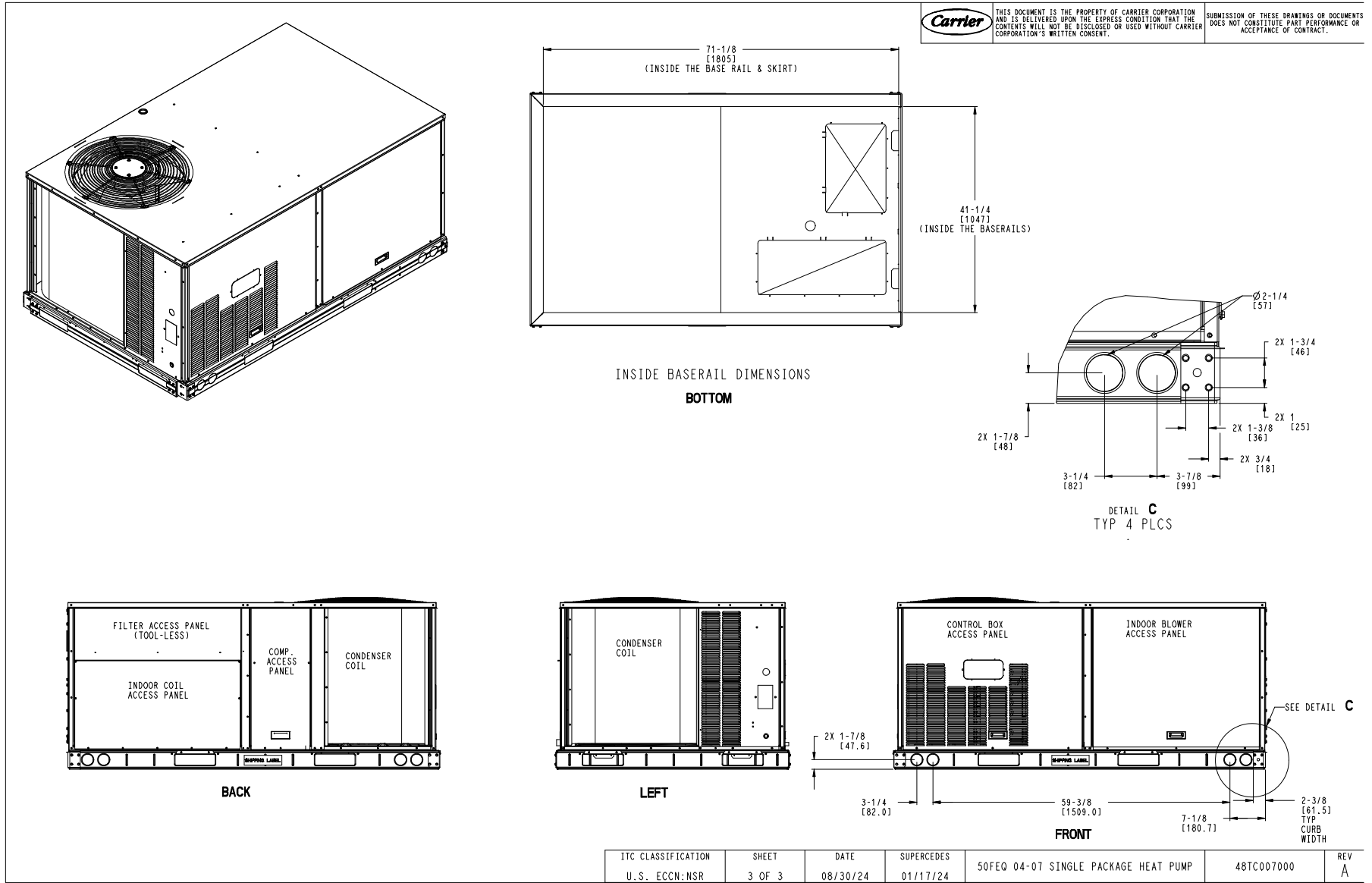

# Certified Drawing for RTU HP - 5 Ton

Project: FL1B  
Prepared By: Jeff Gries

08/01/2025  
02:33PM

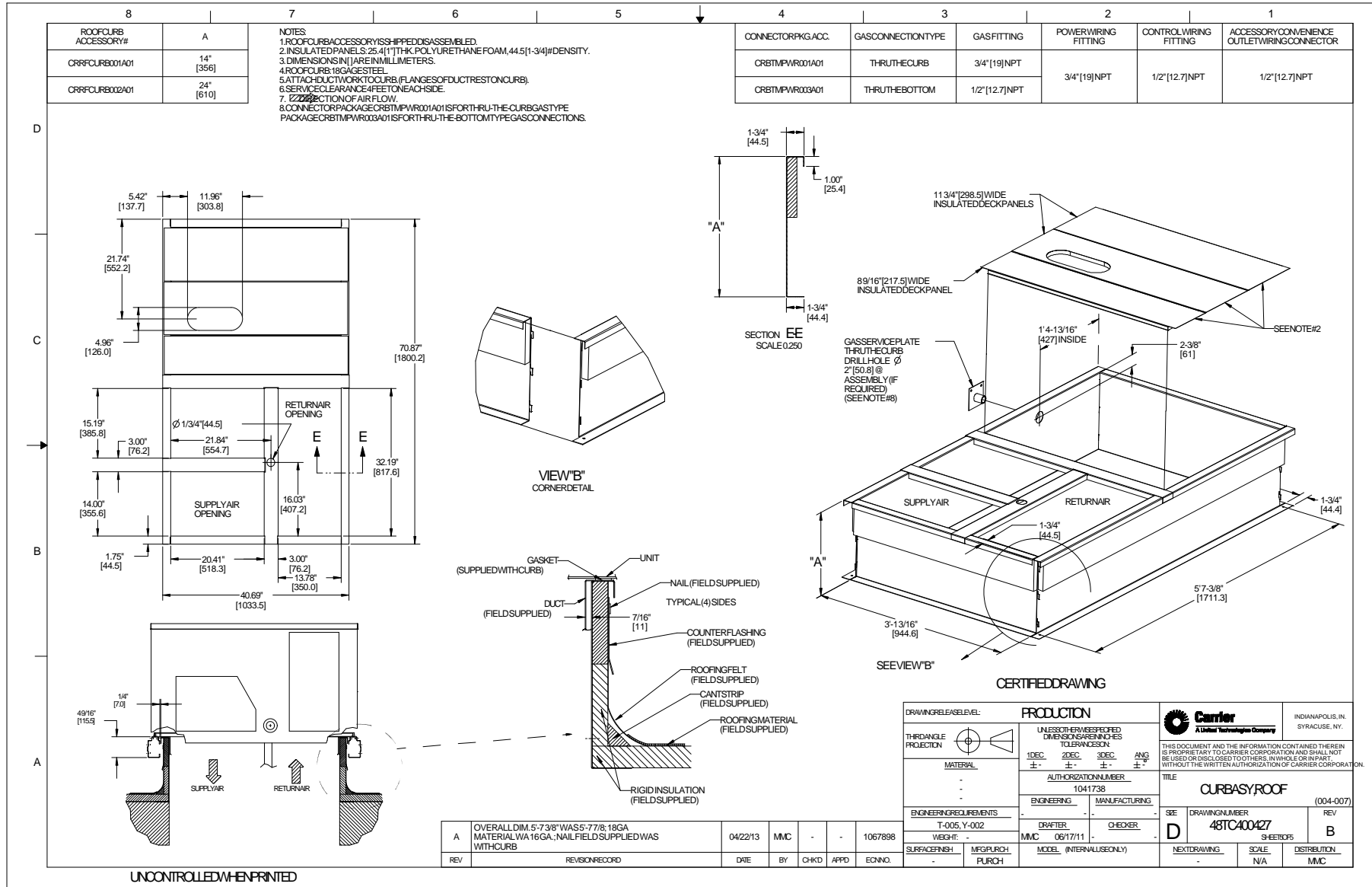

# Performance Summary For RTU HP - 5 Ton

Project: FL1B  
 Prepared By: Jeff Gries

08/01/2025  
 02:33PM

## Part Number:50FEQA06A2A6-3F0A0

Refrigerant:..... **R-454B**  
 ARI SEER2:..... **13.40**

### Base Unit Dimensions

Unit Length:..... **74.4** in  
 Unit Width:..... **46.6** in  
 Unit Height:..... **41.4** in

### Operating Weight

Base Unit Weight:..... **584** lb  
 SystemVu Controller:..... **2** lb  
 Standard Leak Enthalpy Economizer with Barometric Relief:..... **37** lb

### Accessories

14-inch Tall Roof Curb:..... **115** lb  
 Electric Heater:..... **10** lb  
 Single Point Kit:..... **10** lb

Total Operating Weight:..... **758** lb

### Unit

Unit Voltage-Phase-Hertz:.....	<b>460-3-60</b>
Air Discharge:.....	<b>Vertical</b>
Fan Drive Type:.....	<b>Vane Axial</b>
Actual Airflow:.....	<b>2000</b> CFM
Site Altitude:.....	<b>0</b> ft

### Cooling Performance

Condenser Entering Air DB:..... **95.0** F  
 Evaporator Entering Air DB:..... **80.0** F  
 Evaporator Entering Air WB:..... **67.0** F  
 Entering Air Enthalpy:..... **31.44** BTU/lb  
 Evaporator Leaving Air DB:..... **57.1** F  
 Evaporator Leaving Air WB:..... **57.0** F  
 Evaporator Leaving Air Enthalpy:..... **24.40** BTU/lb  
 Gross Cooling Capacity:..... **63.36** MBH  
 Gross Sensible Capacity:..... **49.49** MBH  
 Compressor Power Input:..... **4.05** kW  
 Coil Bypass Factor:..... **0.013**

### Heating Performance

Outdoor Ambient Temperature:..... **47.0** F  
 Entering Air Indoor Coil DB:..... **70.0** F  
 Leaving Air Indoor Coil DB:..... **96.3** F  
 Total Heating Capacity:..... **56.90** MBH  
 Integrated Heating Capacity:..... **56.90** MBH  
 Heating Power Input:..... **4.30** kW  
 High Temperature COP2:..... **3.70**  
 Low Temperature COP2:..... **2.20**  
 HSPF2:..... **6.7**  
 Electric Heating Capacity:..... **19.70** kW  
 Unit Leaving Air Temp:..... **127.5** F

### Supply Fan

External Static Pressure:.....	<b>1.00</b> in wg
Options / Accessories Static Pressure	
Electric Heaters:.....	<b>0.23</b> in wg
Economizer:.....	<b>0.12</b> in wg
Application External Static (ESP + Unit Opts/Acc.):.....	<b>1.35</b> in wg
Fan RPM:.....	<b>2233</b>

# Performance Summary For RTU HP - 5 Ton

Project: FL1B  
Prepared By: Jeff Gries

08/01/2025  
02:33PM

Fan Power: ..... **1.19 BHP**

NOTE: ..... Selected IFM RPM Range: 1228 - 2390

**Selection includes construction throwaway filter into the base fan curve. This filter is not MERV Rated.**

**Electrical Data**

Voltage Range: ..... **414 - 506**  
 Compressor #1 RLA: ..... **9.5**  
 Compressor #1 LRA: ..... **58**  
 Actual Electric Heater kW: ..... **19.7**  
 Electric Heater FLA: ..... **25.9**  
 Indoor Fan Motor Type: ..... **MED**  
 Indoor Fan Motor FLA (Total): ..... **2.1**  
 Power Supply MCA: ..... **48**  
 Power Supply MOCP (Fuse or HACR): ..... **50**  
 Disconnect Size FLA: ..... **44**  
 Disconnect Size LRA: ..... **89**  
 Electrical Convenience Outlet: ..... **None**  
 Outdoor Fan [Qty / FLA (ea)]: ..... **1 / 0.8**  
 Electric Heater Part Number: ..... **337A**  
 Electric Heater Number of Stages: ..... **2**

**Control Panel SCCR: 5kA RMS at Rated Symmetrical Voltage**

**Acoustics**

Sound Power Levels, db re 10E-12 Watts

	Discharge	Inlet	Outdoor
63 Hz	94.6	92.0	85.6
125 Hz	86.2	82.1	84.7
250 Hz	80.2	73.7	80.5
500 Hz	76.0	69.1	76.0
1000 Hz	73.2	70.6	72.4
2000 Hz	70.3	61.7	68.0
4000 Hz	66.2	55.3	62.8
8000 Hz	61.7	48.8	59.3
A-Weighted	79.6	74.6	79.0

**Advanced Acoustics**

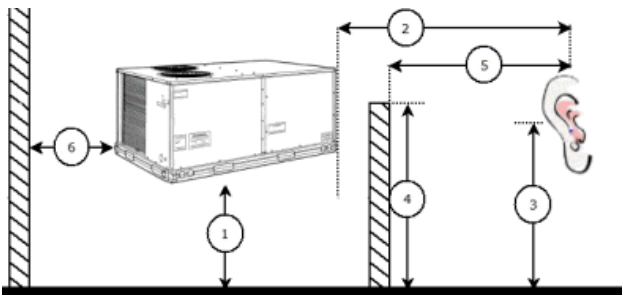

**Advanced Acoustics Parameters**

1. Unit height above ground: ..... **30.0** ft  
 2. Horizontal distance from unit to receiver: ..... **50.0** ft  
 3. Receiver height above ground: ..... **5.7** ft  
 4. Height of obstruction: ..... **0.0** ft  
 5. Horizontal distance from obstruction to receiver: ..... **0.0** ft  
 6. Horizontal distance from unit to obstruction: ..... **0.0** ft

# Performance Summary For RTU HP - 5 Ton

Project: FL1B  
Prepared By: Jeff Gries

08/01/2025  
02:33PM

## Detailed Acoustics Information

Octave Band Center Freq. Hz	63	125	250	500	1k	2k	4k	8k	Overall
A	85.6	84.7	80.5	76.0	72.4	68.0	62.8	59.3	89.2 Lw
B	59.4	68.6	71.9	72.8	72.4	69.2	63.8	58.2	78.5 LwA
C	53.2	52.3	48.1	43.6	40.0	35.6	30.4	26.9	56.8 Lp
D	27.0	36.2	39.5	40.4	40.0	36.8	31.4	25.8	46.1 LpA

### Legend

- A Sound Power Levels at Unit's Acoustic Center, Lw
- B A-Weighted Sound Power Levels at Unit's Acoustic Center, LwA
- C Sound Pressure Levels at Specific Distance from Unit, Lp
- D A-Weighted Sound Pressure Levels at Specific Distance from Unit, LpA

Calculation methods used in this program are patterned after the ASHRAE Guide; other ASHRAE Publications and the AHRI Acoustical Standards. While a very significant effort has been made to insure the technical accuracy of this program, it is assumed that the user is knowledgeable in the art of system sound estimation and is aware of the tolerances involved in real world acoustical estimation. This program makes certain assumptions as to the dominant sound sources and sound paths which may not always be appropriate to the real system being estimated. Because of this, no assurances can be offered that this software will always generate an accurate sound prediction from user supplied input data. If in doubt about the estimation of expected sound levels in a space, an Acoustical Engineer or a person with sound prediction expertise should be consulted.

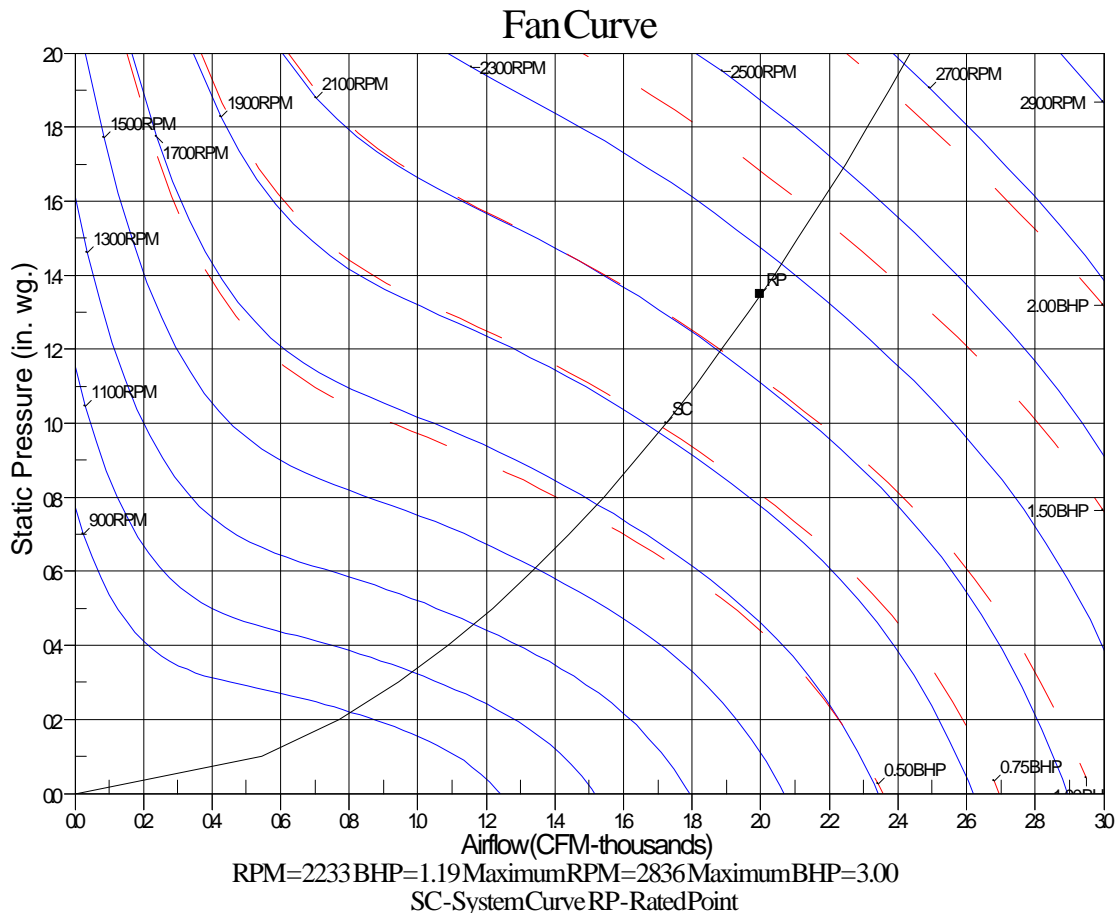

# Unit Feature Sheet for RTU HP - 5 Ton

Project: FL1B  
Prepared By: Jeff Gries

08/01/2025  
02:33PM



## PURON ADVANCE™ PACKAGED ROOFTOP HEAT PUMP UNITS WITH OPTIONAL ACCESSORY ELECTRIC HEAT 3, 4, 5 TONS – 13.4 SEER2, 6 TON – 15.0 IEER

50FEQ units are single-packaged heat pump units with optional accessory electric heat. All units are prewired and pre-charged with Carrier's new, low global warming potential Puron Advance™ (R-454B) refrigerant. Puron Advance represents a 75% reduction in refrigerant GWP over legacy Puron™ (R-410A) models. All units are factory tested in both heating and cooling modes. 3–5-ton models use single stage cooling capacity control. 6-ton models use two stage cooling capacity control.



Use of the AHRI Certified™ Mark indicates a manufacturer's participation in the program. For verification of certification for individual products, go to [www.ahridirectory.org](http://www.ahridirectory.org).



### PERFORMANCE FEATURES

- Puron Advance (R-454B) refrigerant
- Single-stage cooling capacity 04-06 models, Two Stage on 07 models
- SEER2s up to 13.4, HSPF2 up to 6.7
- IEERs up to 15.0, COP up to 3.4
- New - A2L leak detection and dissipation system factory installed standard
- Leak system ensures unit and occupant safety during operation and includes an alarm relay for optional use
- Onboard recallable leak detection history for easier troubleshooting and service
- **Direct Drive** – EcoBlue™ Technology Indoor fan system uses Vane Axial fan design and electronically commutated motor
- New Unit Control Board with intuitive quick fan speed adjustment
- Copper tube aluminum fin coils with optional coating
- Sound levels as low as 75 dB
- Exclusive non-corrosive composite condensate pans in accordance with ASHRAE 62 Standard, sloping design; side or center drain
- Pre-painted exterior panels and primer-coated interior panels tested to 500 hours salt spray protection
- Acutrol™ refrigerant metering system on 04-06 models, TXV on 07 size models
- Standard cooling operating range up to 115°F (46°C), and down to 40°F (4°C). Low Ambient allows cooling operation down to -20°F (-29°C).
- Rated in accordance with AHRI Standards 210/240 (04-06 sizes) and 340/360 (07 size)
- Designed in accordance with Underwriters' Laboratories Standard UL 60335-1 and UL 60335-2-40
- Listed by UL and CUL-Canada

### MAINTENANCE FEATURES

- Access panels with easy grip handles
- Innovative, easy starting, no-strip screw feature on unit access panels
- **Two-inch disposable return air filters**
- Tool-less filter access door
- New central terminal board facilitating simple safety circuit troubleshooting and simplified control box arrangement

### INSTALLATION FEATURES

- Field Convertible from vertical to horizontal airflow on all models. No special kit required.
- Provisions for thru-the-bottom power entry capability
- Single point electric connections
- Full perimeter base rail with built-in rigging adapters and fork truck slots
- Two stage cooling thermostats required on 07 size to help provide energy saving and comfort benefits.

### STANDARD LIMITED PARTS WARRANTY

- 5-year compressor parts
- 5-year electric heater
- 3-year SystemVu™ controller
- 1-year parts

### AVAILABLE OPTIONS:

- Through the base connections for electric available as option
- Disconnect and convenience outlet options
- Medium and High static motor options
- Smoke detector, supply and/or return air
- Corrosion resistant options for evaporator and condenser coils
- CO2 Sensor
- Phase Monitor Protection
- 4" MERV-13 Filters
- Accessory electric heat
- 2-position damper
- Hinged access panels
- Integrated economizer system, Low and ULTRA Low Leak versions.
- Condensate overflow switch
- SystemVu Controls

**RTU HP - 25 Ton**

**Tag Cover Sheet  
Unit Report  
Certified Drawing  
Performance Report  
Guide Specification  
Unit Feature Sheet  
Spec Sheet**

# Unit Report For RTU HP - 25 Ton

Project: FL1B  
 Prepared By: Jeff Gries

08/01/2025  
 02:33PM

Unit Parameters		RTU-1 THRU 31
Unit Model:	50FEQM28A2A6-3W0A0	
Unit Size:	28 (25.0 Tons)	
Volts-Phase-Hertz:	460-3-60	
Heating Type:	Heat Pump	
Refrigerant:	R-454B	
Heat Control:	Two-Stage Cooling / One Circuit	
Duct Cfg:	Vertical Supply / Vertical Return	

Dimensions (ft. in.) & Weight (lb.) ***	
Unit Length:	11' 9.5"
Unit Width:	7' 2.375"
Unit Height:	3' 11.75"
<b>Total Operating Weight:</b>	<b>2574 lb</b>

\*\*\* Weights and Dimensions are approximate. Weight does not include unit packaging. Approximate dimensions are provided primarily for shipping purposes. For exact dimensions and weights, refer to appropriate product data catalog.

Lines and Filters	
Return Air Filter Type:	Throwaway
Return Air Filter Quantity:	9
Return Air Filter Size:	16 x 25 x 2

Selection includes construction throwaway filter into the base fan curve.

- Unit Configuration**
- Std / Med Static - EcoBlue Vane Axial Fan, Vert Supply
  - Al/Cu - Al/Cu
  - SystemVu Controller
  - Enthalpy Ultra Low Leak Economizer with Barometric Relief
  - Standard Packaging
  - UL60335-2-40 approved R-454B Dissipation board and leak sensor included as standard

- Warranty Information**
- 5-Year electric heaters (STD.)
  - 1-Year parts (STD.)
  - 5-Year Compressor (std.)

No optional warranties were selected.

**Ordering Information**

Part Number	Description	Quantity
50FEQM28A2A6-3W0A0	Rooftop Unit	1
	Base Unit	
	SystemVu controller, ULTRA LOW LEAK EconoMi\$er2 enthalpy economizer with barometric relief	
<b>Field Installed Accessories</b>		
CRRFCURB047A00	14-inch Tall Roof Curb	1
ZS2P-CAR	ZS Pro	1
CRHEATER459A00	Electric Heater	1
CRSINGLE057A00	Single Point Kit	1

# Certified Drawing for RTU HP - 25 Ton

Project: FL1B  
Prepared By: Jeff Gries

08/01/2025  
02:33PM

**Carrier** THIS DOCUMENT IS THE PROPERTY OF CARRIER CORPORATION AND IS DELIVERED UPON THE EXPRESS CONDITION THAT THE CONTENTS WILL NOT BE DISCLOSED OR USED WITHOUT CARRIER CORPORATION'S WRITTEN CONSENT. SUBMISSION OF THESE DRAWINGS OR DOCUMENTS DOES NOT CONSTITUTE PART PERFORMANCE OR ACCEPTANCE OF CONTRACT.

CONNECTION SIZES	
A	1 3/8" DIA [35] FIELD POWER SUPPLY KNOCKOUT
B	3" DIA [76] FIELD POWER SUPPLY KNOCKOUT
C	3 5/8" DIA [92] FIELD POWER SUPPLY KNOCKOUT
D	7/8" DIA [22] FIELD CONTROL WIRING HOLE
G	7/8" DIA [22] FIELD CONTROL WIRING KNOCKOUT

UNIT	H
24 SIZE	57-3/8 [1456]
28 SIZE	57-3/8 [1456]

- NOTES:
1. DIMENSIONS ARE IN INCHES. DIMENSIONS IN [ ] ARE IN MILLIMETERS.
  2. CENTER OF GRAVITY
  3. DIRECTION OF AIR FLOW
  4. ALL VIEW DRAWN USING 3RD ANGLE

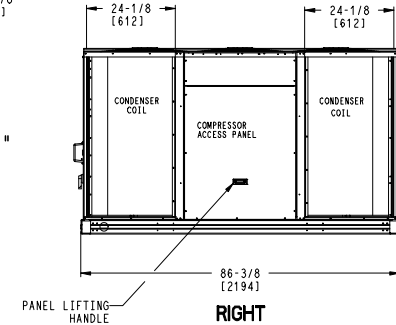
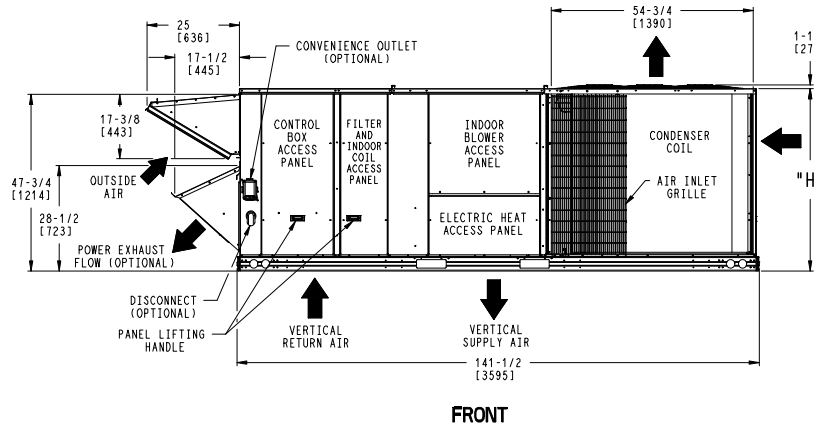
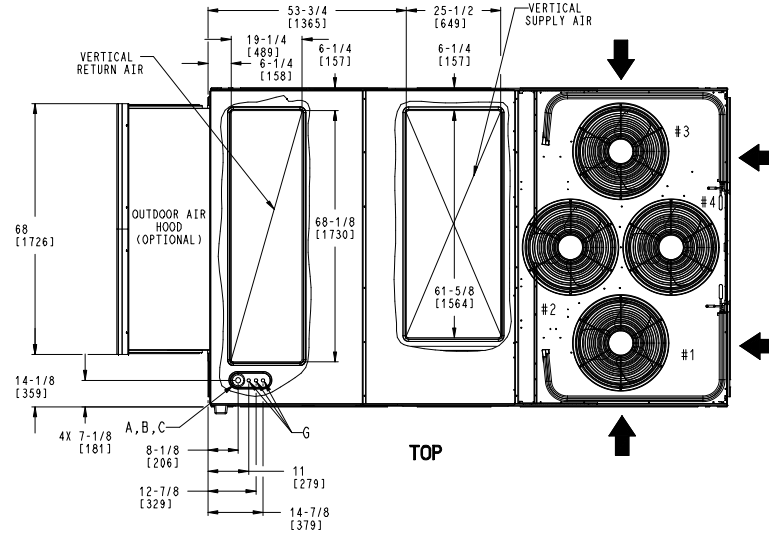
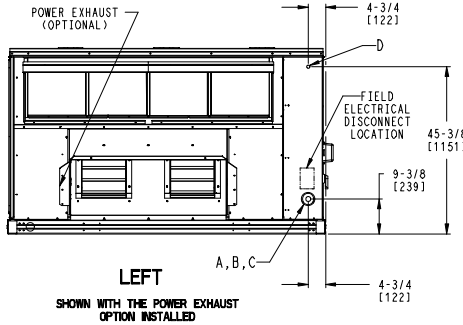
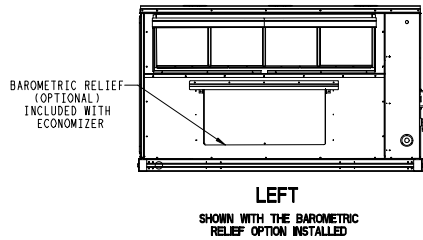
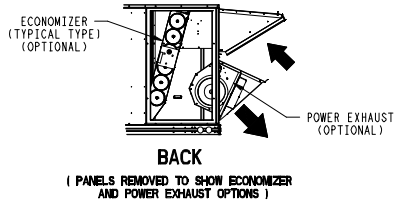

**DEDICATED VERTICAL AIRFLOW UNIT  
24,28 SIZE**

ITC CLASSIFICATION U.S. ECCN: NSR	SHEET 1 OF 5	DATE 05/21/24	SUPERCEDES -	50FEQ 24,28 SINGLE ZONE ELECTRICAL HEAT PUMP	50HE004890	REV -
--------------------------------------	-----------------	------------------	-----------------	--	------------	----------

# Certified Drawing for RTU HP - 25 Ton

Project: FL1B  
Prepared By: Jeff Gries

08/01/2025  
02:33PM

CONNECTION SIZES	
E	3/4"-14 NPT CONDENSATE DRAIN

**Carrier**

THIS DOCUMENT IS THE PROPERTY OF CARRIER CORPORATION AND IS DELIVERED UPON THE EXPRESS CONDITION THAT THE CONTENTS WILL NOT BE DISCLOSED OR USED WITHOUT CARRIER CORPORATION'S WRITTEN CONSENT.

SUBMISSION OF THESE DRAWINGS OR DOCUMENTS DOES NOT CONSTITUTE PART PERFORMANCE OR ACCEPTANCE OF CONTRACT.

UNIT	G
24 SIZE	49-1/4 [1251]
28 SIZE	49-1/4 [1251]

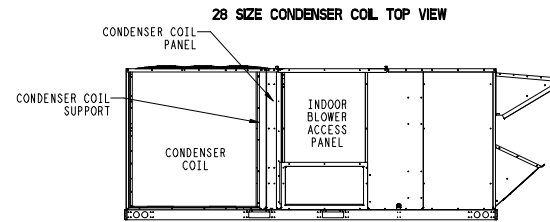
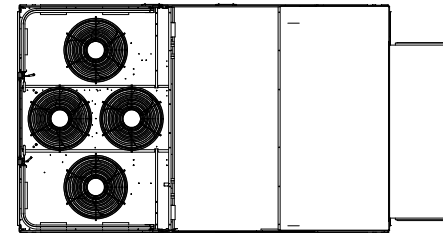
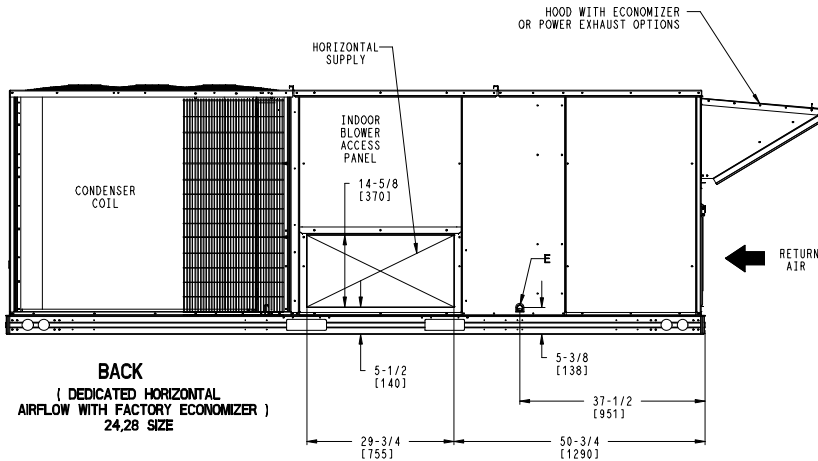
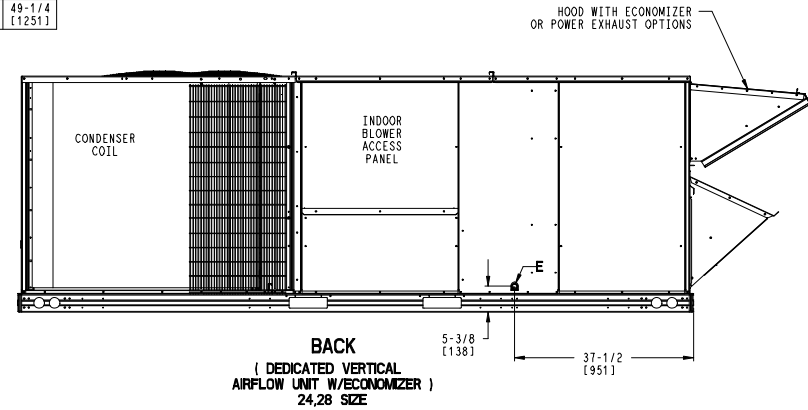
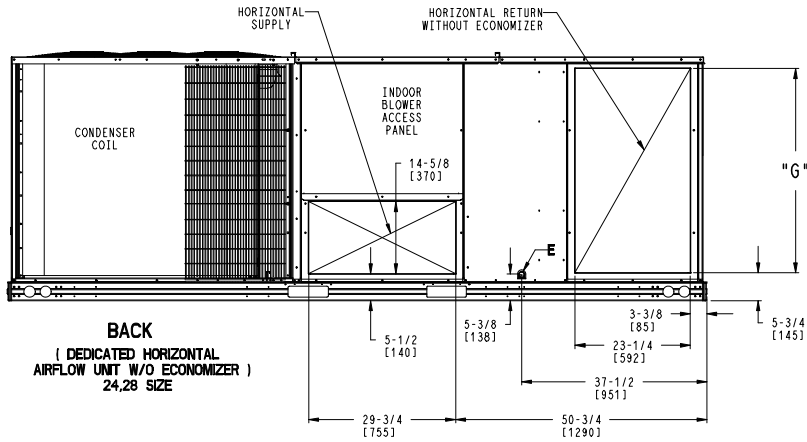

ITC CLASSIFICATION	SHEET	DATE	SUPERCEDES	50FEQ 24,28 SINGLE ZONE ELECTRICAL HEAT PUMP	50HE004890	REV
U. S. ECCN: NSR	3 OF 5	05/21/24	-			-

# Certified Drawing for RTU HP - 25 Ton

Project: FL1B  
Prepared By: Jeff Gries

08/01/2025  
02:33PM

UNIT	STD. UNIT WEIGHT *		CORNER WEIGHT (A)		CORNER WEIGHT (B)		CORNER WEIGHT (C)		CORNER WEIGHT (D)		C.G.		
	LBS.	KG.	LBS.	KG.	LBS.	KG.	LBS.	KG.	LBS.	KG.	X	Y	Z
50FEQ 24	2057	933	466	211	531	241	565	256	495	225	75 3/8 [1915]	44 1/2 [1130]	19 [483]
50FEQ 28	2125	964	465	211	556	252	601	273	503	228	77 [1956]	44 7/8 [1140]	19 [483]

**Carrier** THIS DOCUMENT IS THE PROPERTY OF CARRIER CORPORATION AND IS DELIVERED UPON THE EXPRESS CONDITION THAT THE CONTENTS WILL NOT BE DISCLOSED OR USED WITHOUT CARRIER CORPORATION'S WRITTEN CONSENT. SUBMISSION OF THESE DRAWINGS OR DOCUMENTS DOES NOT CONSTITUTE PART PERFORMANCE OR ACCEPTANCE OF CONTRACT.

\* STANDARD UNIT WEIGHT IS WITHOUT ELECTRIC HEAT AND WITHOUT PACKAGING. FOR OTHER OPTIONS AND ACCESSORIES, REFER TO THE PRODUCT DATA CATALOG.

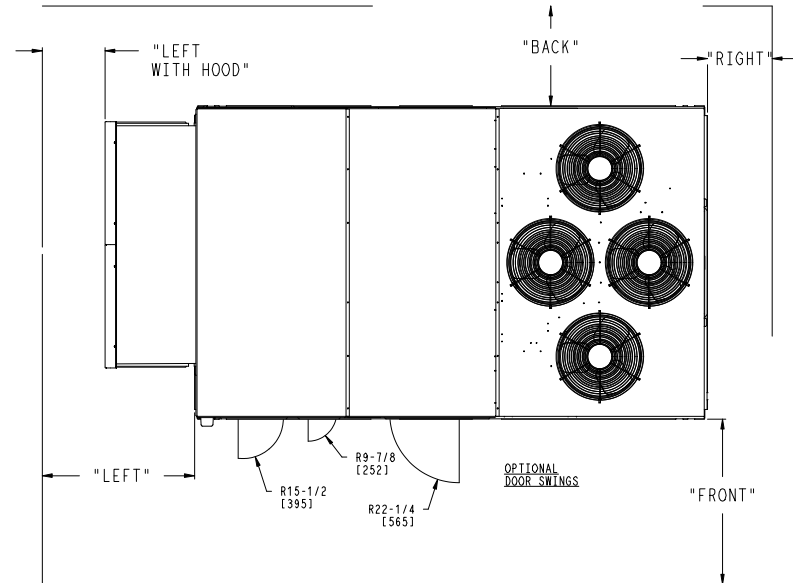
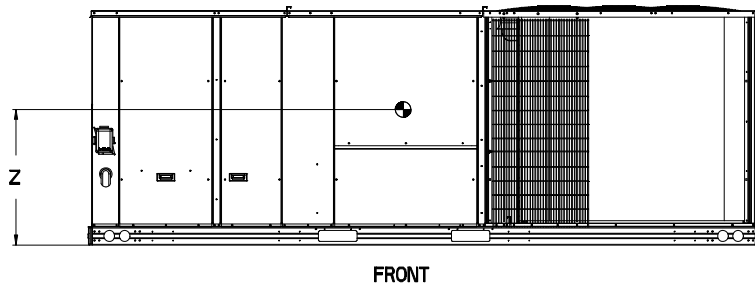
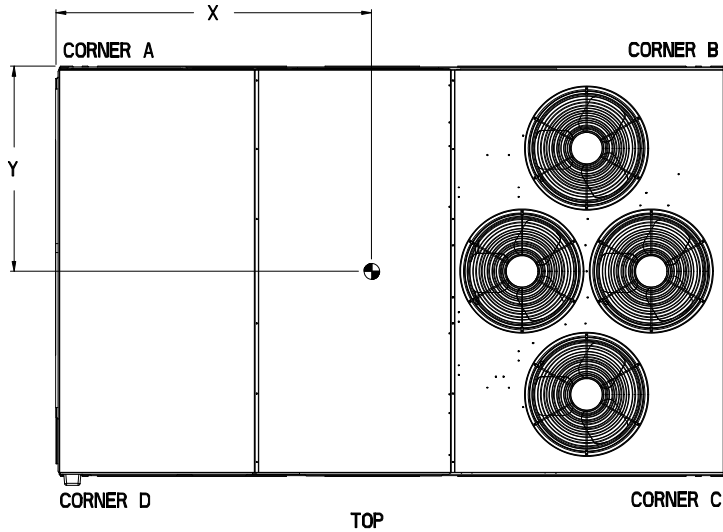

**NOTES:**

- CLEARANCE ABOVE THE UNIT TO BE 72"
- FOR ALL MINIMUM CLEARANCES LOCAL CODES OR JURISDICTIONS MAY PREVAIL.

SURFACE	CLEARANCE		OPERATING CLEARANCE
	SERVICE WITH CONDUCTIVE BARRIER	SERVICE WITH NONCONDUCTIVE BARRIER	
FRONT	48 [1219mm]	36 [914mm]	18 [457mm]
LEFT	48 [1219mm]	42 [1067mm]	18 [457mm]
BACK	42 [1067mm]	36 [914mm]	18 [457mm]
LEFT WITH HOOD	36 [914mm]	36 [914mm]	18 [457mm]
RIGHT	36 [914mm]	36 [914mm]	18 [457mm]
TOP	72 [1829mm]	72 [1829mm]	72 [1829mm]

ITC CLASSIFICATION	SHEET	DATE	SUPERCEDES	50FEQ 24,28 SINGLE ZONE ELECTRICAL HEAT PUMP	50HE004890	REV
U.S. ECCN:NSR	4 OF 5	05/21/24	-			-

# Certified Drawing for RTU HP - 25 Ton

Project: FL1B  
Prepared By: Jeff Gries

08/01/2025  
02:33PM

	THIS DOCUMENT IS THE PROPERTY OF CARRIER CORPORATION AND IS DELIVERED UPON THE EXPRESS CONDITION THAT THE CONTENTS WILL NOT BE DISCLOSED OR USED WITHOUT CARRIER CORPORATION'S WRITTEN CONSENT.	SUBMISSION OF THESE DRAWINGS OR DOCUMENTS DOES NOT CONSTITUTE PART PERFORMANCE OR ACCEPTANCE OF CONTRACT.
---	---	---

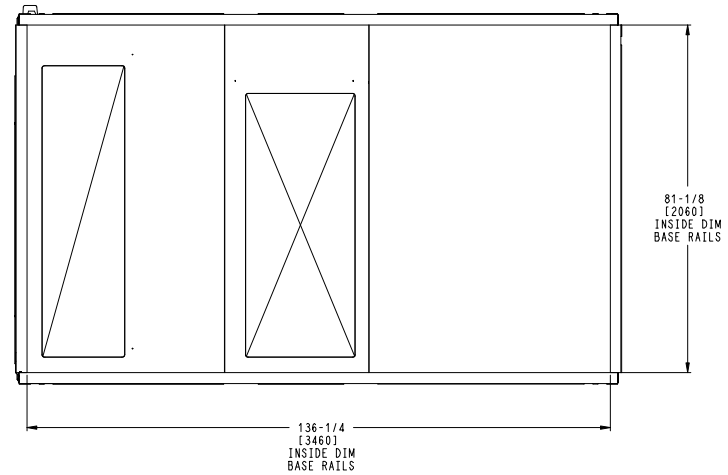
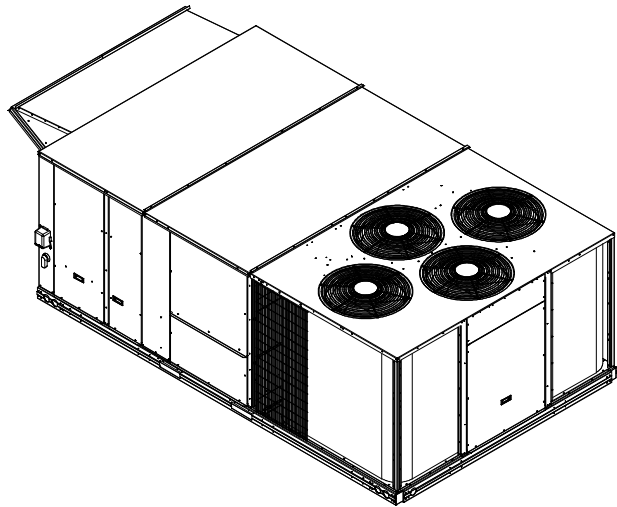

**BOTTOM**  
INSIDE BASERAIL DIMENSIONS

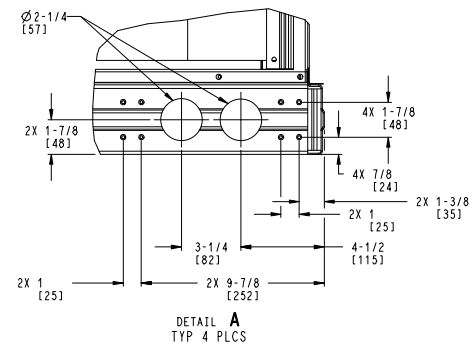
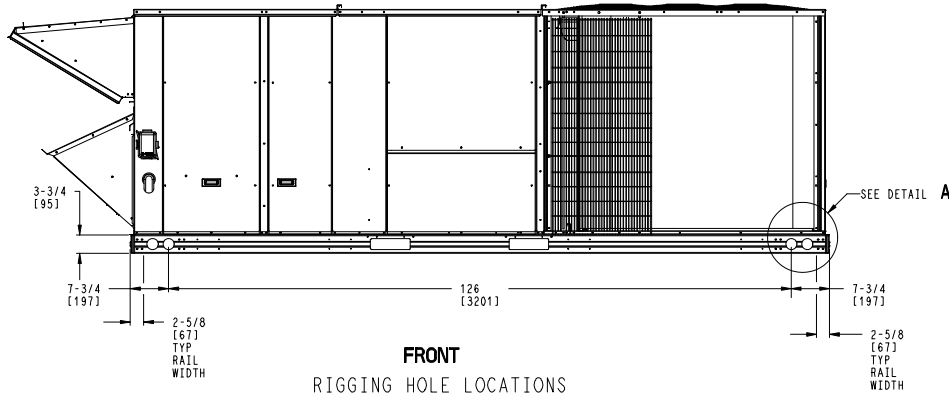

ITC CLASSIFICATION	SHEET	DATE	SUPERCEDES	50FEQ 24,28 SINGLE ZONE ELECTRICAL HEAT PUMP	50HE004890	REV
U. S. ECCN: NSR	5 OF 5	05/21/24	-			-



# Performance Summary For RTU HP - 25 Ton

Project: FL1B  
Prepared By: Jeff Gries

08/01/2025  
02:33PM

## Part Number: 50FEQM28A2A6-3W0A0

Refrigerant:..... **R-454B**  
ARI EER:..... **9.50**  
IEER:..... **14.0**

### Base Unit Dimensions

Unit Length:..... **141.5** in  
Unit Width:..... **86.4** in  
Unit Height:..... **47.8** in

### Operating Weight

Base Unit Weight:..... **2125** lb  
SystemVu Controller:..... **2** lb  
Enthalpy Ultra Low Leak Economizer with Barometric Relief:..... **103** lb

### Accessories

14-inch Tall Roof Curb:..... **255** lb  
Single Point Kit:..... **15** lb

Total Operating Weight:..... **2574** lb

### Unit

Unit Voltage-Phase-Hertz:..... **460-3-60**  
Air Discharge:..... **Vertical**  
Fan Drive Type:..... **Vane Axial**  
Actual Airflow:..... **10000** CFM  
Site Altitude:..... **0** ft

### Cooling Performance

Condenser Entering Air DB:..... **95.0** F  
Evaporator Entering Air DB:..... **80.0** F  
Evaporator Entering Air WB:..... **67.0** F  
Entering Air Enthalpy:..... **31.44** BTU/lb  
Evaporator Leaving Air DB:..... **58.9** F  
Evaporator Leaving Air WB:..... **57.8** F  
Evaporator Leaving Air Enthalpy:..... **24.87** BTU/lb  
Gross Cooling Capacity:..... **295.39** MBH  
Gross Sensible Capacity:..... **227.45** MBH  
Compressor Power Input:..... **27.47** kW  
Coil Bypass Factor:..... **0.080**

### Heating Performance

Outdoor Ambient Temperature:..... **47.0** F  
Entering Air Indoor Coil DB:..... **70.0** F  
Leaving Air Indoor Coil DB:..... **95.8** F  
Total Heating Capacity:..... **278.20** MBH  
Integrated Heating Capacity:..... **278.20** MBH  
Heating Power Input:..... **23.34** kW  
High Temperature COP:..... **3.30**  
Low Temperature COP:..... **2.15**  
Electric Heating Capacity:..... **68.90** kW  
Unit Leaving Air Temp:..... **117.5** F

### Supply Fan

External Static Pressure:..... **1.00** in wg  
Options / Accessories Static Pressure  
Electric Heaters:..... **0.19** in wg  
Economizer:..... **0.10** in wg  
Application External Static (ESP + Unit Opts/Acc.):..... **1.30** in wg  
Fan RPM:..... **1739**  
Fan Power:..... **5.03** BHP

# Performance Summary For RTU HP - 25 Ton

Project: FL1B  
Prepared By: Jeff Gries

08/01/2025  
02:33PM

NOTE:.....Selected IFM RPM Range: 1099 - 2200

**Selection includes construction throwaway filter into the base fan curve. This filter is not MERV Rated.**

**Electrical Data**

Voltage Range:.....	414 - 506
Compressor #1 RLA:.....	22.4
Compressor #1 LRA:.....	150
Compressor #2 RLA:.....	21.6
Compressor #2 LRA:.....	147
Actual Electric Heater kW:.....	68.9
Electric Heater FLA:.....	90.2
Indoor Fan Motor Type:.....	MED
Indoor Fan Motor FLA (Total):.....	3.5
Power Supply MCA:.....	150
Power Supply MOCP (Fuse or HACR):.....	175
Disconnect Size FLA:.....	167
Disconnect Size LRA:.....	405
Electrical Convenience Outlet:.....	None
Outdoor Fan [Qty / FLA (ea)]:.....	4 / 0.9
Electric Heater Part Number:.....	CRHEATER459A00
Electric Heater Number of Stages:.....	2

**Control Panel SCCR: 5kA RMS at Rated Symmetrical Voltage**

**Acoustics**

Sound Power Levels, db re 10E-12 Watts

	Discharge	Inlet	Outdoor
63 Hz	94.3	80.6	97.1
125 Hz	92.3	77.0	88.3
250 Hz	89.6	72.7	84.4
500 Hz	87.6	70.4	83.3
1000 Hz	82.4	69.1	80.7
2000 Hz	80.6	63.8	77.4
4000 Hz	76.1	55.1	73.4
8000 Hz	66.9	46.3	67.3
A-Weighted	89.2	73.3	85.9

**Advanced Acoustics**

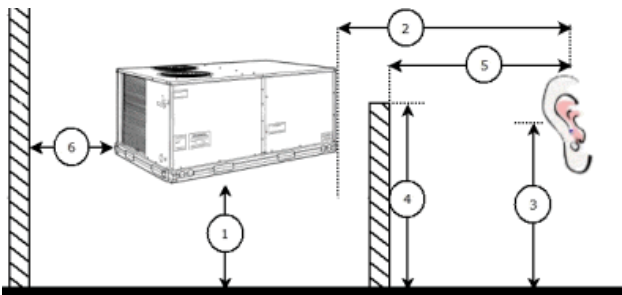

**Advanced Acoustics Parameters**

1. Unit height above ground:.....	30.0	ft
2. Horizontal distance from unit to receiver:.....	50.0	ft
3. Receiver height above ground:.....	5.7	ft
4. Height of obstruction:.....	0.0	ft
5. Horizontal distance from obstruction to receiver:.....	0.0	ft

# Performance Summary For RTU HP - 25 Ton

Project: FL1B  
Prepared By: Jeff Gries

08/01/2025  
02:33PM

6. Horizontal distance from unit to obstruction:.....**0.0** ft

## Detailed Acoustics Information

Octave Band Center Freq. Hz	63	125	250	500	1k	2k	4k	8k	Overall
A	97.1	88.3	84.4	83.3	80.7	77.4	73.4	67.3	98.1 Lw
B	70.9	72.2	75.8	80.1	80.7	78.6	74.4	66.2	85.9 LwA
C	64.7	55.9	52.0	50.9	48.3	45.0	41.0	34.9	65.7 Lp
D	38.5	39.8	43.4	47.7	48.3	46.2	42.0	33.8	53.5 LpA

### Legend

- A Sound Power Levels at Unit's Acoustic Center, Lw
- B A-Weighted Sound Power Levels at Unit's Acoustic Center, LwA
- C Sound Pressure Levels at Specific Distance from Unit, Lp
- D A-Weighted Sound Pressure Levels at Specific Distance from Unit, LpA

Calculation methods used in this program are patterned after the ASHRAE Guide; other ASHRAE Publications and the AHRI Acoustical Standards. While a very significant effort has been made to insure the technical accuracy of this program, it is assumed that the user is knowledgeable in the art of system sound estimation and is aware of the tolerances involved in real world acoustical estimation. This program makes certain assumptions as to the dominant sound sources and sound paths which may not always be appropriate to the real system being estimated. Because of this, no assurances can be offered that this software will always generate an accurate sound prediction from user supplied input data. If in doubt about the estimation of expected sound levels in a space, an Acoustical Engineer or a person with sound prediction expertise should be consulted.

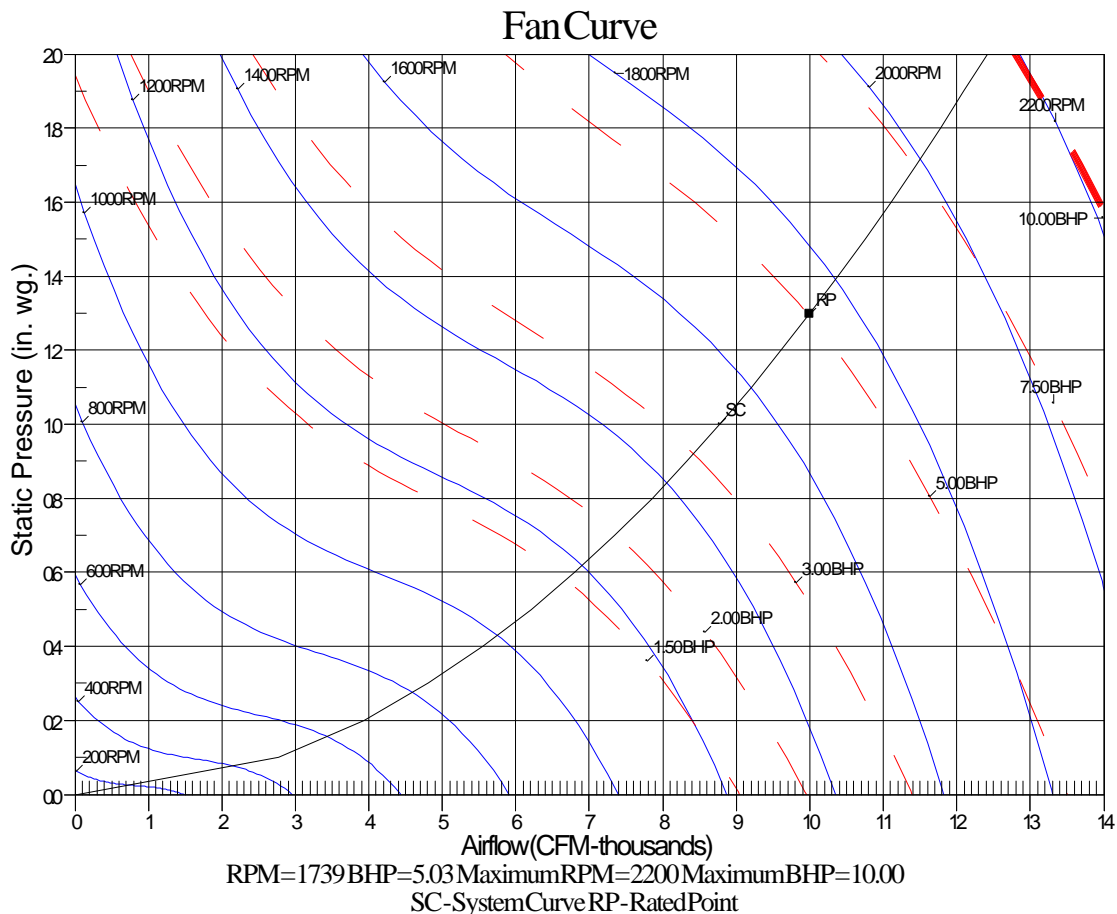

# Guide Specification for RTU HP - 25 Ton

Project: FL1B  
Prepared By: Jeff Gries

08/01/2025  
02:33PM

Note about this specification:

This specification is in the "Masterformat" as published by the Construction Specification Institute. Please feel free to copy this specification directly into your building spec.



## Heat Pump Packaged Rooftop

### HVAC Guide Specifications

Size Range: **15 to 25 Nominal Tons**

Carrier Model Number: **50FEQ\*17-28**

#### **(230680) Schedules for Decentralized HVAC Equipment**

(230680.13) Decentralized Unitary HVAC Equipment Schedule

(230680.13.A.) Rooftop unit (RTU) schedule:

Schedule is per the project specification requirements.

#### **(230716) HVAC equipment insulation**

(230716.13) Decentralized, Rooftop Units:

(230716.13.A.) Evaporator fan compartment:

1. Interior cabinet surfaces shall be insulated with a minimum 1/2 in. thick, minimum 1-1/2 lb density, flexible fiberglass insulation bonded with a phenolic binder, neoprene coated on the air side.

2. Insulation and adhesive shall meet NFPA 90A requirements for flame spread and smoke generation.

(230716.13.B.) Electric Heat Compartment:

1. Aluminum foil-faced fiberglass insulation shall be used.

2. Insulation and adhesive shall meet NFPA 90A requirements for flame spread and smoke generation.

#### **(230913) Instrumentation and control devices for HVAC**

(230913.23) Sensors and Transmitters

(230913.23.A.) Thermostats

1. Thermostat must

a. energize both "W" and "G" when calling for heat.

b. have capability to energize 1 or 2 stages of cooling, and 2 different stages of heating.

c. be heat pump design and include capability for occupancy scheduling.

#### **(230923) Direct Digital Control system for HVAC**

(230923.13) Decentralized, Rooftop Units:

**(230923.13.A.)** SystemVu™ intelligent integrated Direct Digital Control (DDC) shall provide:

1. Integrated unit operation for comfort cooling, heating ventilation as well as all monitoring, recording and reporting capabilities. Controller shall also provide diagnostics and alarms of abnormal unit operation through the controller. Controller shall have an intuitive user display and be able to be used in a standalone operation or via building automation system (BAS).

## Guide Specification for RTU HP - 25 Ton

Project: FL1B  
Prepared By: Jeff Gries

08/01/2025  
02:33PM

2. Quick Unit Status LEDs of: Run — meaning all systems are go, ALERT — that indicates there is currently a non-critical issue with the unit, like filters need to be replaced and FAULT — that indicates the unit has a critical issue and will possibly shut down.
3. Six large navigation keys for easy access. Navigation keys shall consist of: TEST, BACK, ENTER, and MENU along with UP and DOWN arrows.
4. Full backlit user display with 4 line by 30 character text capabilities. Display menu shall be designed to provide guided major menus and sub menus main menus provided below:
  - a. Shutdown Unit
  - b. Run Status
  - c. Settings
  - d. Alerts/Faults
  - e. Service
  - f. Inputs
  - g. Outputs
  - h. USB
5. The capability for standalone operation with conventional thermostat/sensor or use with building automation systems (BAS) of Carrier i-Vu<sup>®</sup>, BACnet, and Carrier Comfort Network<sup>®</sup> (CCN) systems. No special modules or boards are required for these capabilities. Has the capability to work with Equipment Touch<sup>™</sup> and System Touch<sup>™</sup> devices and ZS Sensors.
6. The ability to read refrigerant pressures at display or via BAS network of; Discharge Pressure and Suction Pressure. The need for traditional refrigerant gauges is not required.
7. USB Data Port for flash drive interaction. This will allow the transfer of data for uploads, downloads, perform software upgrades, back-up and restore data and file transfer data such as component number of starts and run hours.
8. Reverse Rotation Protection of compressors if field 3-phase wiring is misapplied.
9. Provide Service Capabilities of:
  - a. Auto run test
  - b. Manual run test
  - c. Component run hours and starts
  - d. Commissioning reports
  - e. Data logging
  - f. Alarm history
10. Economizer control and diagnostics. Set up economizer operation, receive feedback from actuator. Also meets the most recent California Title 24, ASHRAE 90.1 and IECC Fault Detection and Diagnostic (FDD) requirements.
11. Unit cooling operation down to 40°F (4°C).
12. Controller shall have easy access connections around the controller perimeter area and consist of Mate-N-Lok, terminal block and RJ style modular jack connections.
13. 365 day real time clock, 20 holiday schedules along with occupied and unoccupied scheduling.
14. Auto-Recognition for easy installation and -commissioning of devices like economizers, space sensors etc.
15. A 5°F temperature difference between cooling and heating set points to meet the latest ASHRAE 90.1 Energy Standard.
16. Contain return air sensor, supply air sensor and outdoor air sensor to help monitor and provide data for the unit comfort operation, diagnostic and alarms.

## Guide Specification for RTU HP - 25 Ton

Project: FL1B  
Prepared By: Jeff Gries

08/01/2025  
02:33PM

17. Use of Carrier's field accessory Equipment Touch and System Touch devices.
18. Units with the factory-installed Humidi-MiZer® system option are capable of providing multiple modes of improved dehumidification as a variation of the normal cooling cycle.
19. Supply Air Tempering control operates the gas or electric heat to maintain a minimum supply air temperature during conditions where very cold outdoor air causes the supply air temperature to fall below the configured Supply Air Tempering Setpoint. This occurs during periods where DCV is active and increasing the amount of outdoor air or in cases where the system is operating at very low airflow and the calculated economizer position has increased to maintain a constant ventilation rate.
20. Demand limiting in SystemVu™ is achieved through set point expansion. The systems heating and cooling set points are expanded in steps or levels. The degree to which the set points may be expanded is defined by the 6 demand level offsets and the 2 commanded demand limit levels.
21. 3-year limited part warranty.

### **(23 09 33) Electric and Electronic Control System for HVAC**

(23 09 33.13) Decentralized, Rooftop Units:

(23 09 33.13.A.) General:

1. Shall be complete with self-contained low-voltage control circuit protected by a resettable circuit breaker on the 24-v transformer side. Transformer shall have 75VA capability.
2. Shall utilize color-coded wiring.
3. Shall include a Unit Control Board to conveniently and safely provide connection points for vital control functions such as: smoke detectors, phase monitor, gas controller, economizer, thermostat, DDC control options, and low and high pressure switches. Controller shall also provide an intuitive means to adjust the indoor fan speed through a simple switch and pot adjustment design.
4. Unit shall include a minimum of one 8-pin screw terminal connection board for connection of control wiring.
5. Shall include integrated defrost system to prevent excessive frost accumulation during heating duty, and shall be controlled as follows:
  - a. Defrost shall be initiated on the basis of time and coil temperature.
  - b. A 30, 60, 90, 120 minute timer shall activate the defrost cycle only if the coil temperature is low enough to indicate a heavy frost condition.
  - c. Defrost cycle shall terminate when defrost thermostat is satisfied and shall have a positive termination time of 10 minutes.
6. Defrost system shall also include:
  - a. Defrost Cycle Indicator LED.
  - b. DIP switch selectable defrost time between 30, 60, 90, and 120 minutes. Factory set at 30 minutes.
  - c. Molded plug connection to ensure proper connection.

(23 09 33.13.B.) Safeties:

1. Compressor over-temperature, over-current. High internal pressure differential.
2. Low pressure switch.

Low pressure switch shall use different color wire than the high pressure switch. The purpose is to assist the installer and service technician to correctly wire and or troubleshoot the rooftop unit.
3. High pressure switch.

High pressure switch shall use different color wire than the low pressure switch. The purpose is to assist the installer and service technician to correctly wire and or troubleshoot the rooftop unit.

## Guide Specification for RTU HP - 25 Ton

Project: FL1B  
Prepared By: Jeff Gries

08/01/2025  
02:33PM

4. Heating section shall be provided with the following minimum protections:

- a. High temperature limit switches.

6. A2L Refrigerant Leak Dissipation System (Electromechanical)

- a. Leak dissipation system shall consist of control board and A2L sensor certified to UL 60335-2-40
- b. System shall be designed for the life of the unit
- c. Dissipation system shall be automatic, ship prewired, and require no additional field connections to thermostat to function
- d. Refrigerant leak sensor shall be installed in UL certified location and orientation. Sensor shall be self-correcting and resettable. Single use refrigerant leak sensor shall not be permitted
- e. Factory installed dissipation controller shall use onboard microprocessor and include:
  - 1) Automatic reset after a dissipation event has occurred
  - 2) Onboard LED with flash code to indicate current unit status and hardware failures
  - 3) Depressible "Test" button to allow for a system test and recall/reset of leak detection history
  - 4) 24V dry contact alarm terminal to allow for external notification of leak detection
- f. Dissipation control board shall be accessible via normal maintenance locations and LED shall be visible
- g. Dissipation system shall "Fail Safe" per UL requirements
- h. Dissipation shall allow smoke and building fire systems to override in case of event

7. A2L Refrigerant Leak Dissipation System (SystemVu)

- a. Leak dissipation system shall consist of control board and A2L sensor certified to UL 60335-2-40, integrated with SystemVu controller
- b. System shall be designed for the life of the unit
- c. Dissipation system shall be automatic, ship prewired, and require no additional field connections to function
- d. Refrigerant leak sensor shall be installed in UL certified location and orientation. Sensor shall be self-correcting and resettable. Single use refrigerant leak sensor shall not be permitted
- e. Factory installed dissipation system shall use onboard microprocessor and include:
  - 1) Automatic leak detection and dissipation algorithm
  - 2) Automatic reset after a dissipation event has occurred
  - 3) Onboard LED with flash code to indicate current unit status and hardware failures
  - 4) Depressible "Test" button to allow for a system test and recall/reset of leak detection history
  - 5) 24V dry contact alarm terminal on dissipation control board to allow for external notification of leak detection
  - 6) Ability to notify BAS system of dissipation event via readable alarm point through SystemVu
  - 7) Recallable dissipation alarm history on SystemVu controller
- f. Dissipation control board shall be accessible via normal maintenance locations and LED shall be visible
- g. Dissipation system shall "Fail Safe" per UL requirements
- h. Dissipation shall allow smoke and building fire systems to override in case of event

## Guide Specification for RTU HP - 25 Ton

Project: FL1B  
Prepared By: Jeff Gries

08/01/2025  
02:33PM

### (230993) Sequence of Operations for HVAC Controls

(230993.13) Decentralized, Rooftop Units:

(230993.13.A.) INSERT SEQUENCE OF OPERATION

### (234013) Panel Air Filters

(234013.13) Decentralized, Rooftop Units:

(234013.13.A.) Standard filter section:

1. Shall consist of factory installed, low velocity, disposable 2 in. thick fiberglass filters of -commercially available sizes.
2. Unit shall use only one filter size. Multiple sizes are not acceptable.
3. Filters shall be accessible through an access panel with "no-tool" removal as described in the unit cabinet section of this specification (2381 19.13.G).

### (238119) Self-Contained Air Conditioners

(2381 19.13) Small-Capacity Self-Contained Air Conditioners:

(2381 19.13.A.) General:

1. Outdoor, rooftop mounted, electrically controlled, heating and cooling unit utilizing a fully hermetic scroll compressor(s) for cooling duty and heat pump heating duty
2. Factory assembled, single-piece heating and cooling rooftop unit. Contained within the unit enclosure shall be all factory wiring, piping, controls, and special features required prior to field start-up.
3. Unit shall use Puron Advance™ (R-454B) refrigerant.
4. Unit shall be installed in accordance with the manufacturer's instructions.
5. Unit must be selected and installed in compliance with local, state, and federal codes.

(2381 19.13.B.) Quality Assurance:

1. Unit meets DOE and ASHRAE 90.1 minimum efficiency requirements.
2. Unit shall be rated in accordance with AHRI Standards 340/360.
3. Unit shall be designed to conform to ASHRAE 15.
4. Unit shall be UL-tested and certified in accordance with ANSI Z21.47 Standards and UL-listed and certified under Canadian standards as a total package for safety requirements.
5. Insulation and adhesive shall meet NFPA 90A requirements for flame spread and smoke generation.
6. Unit casing shall be capable of withstanding 500 hour salt spray exposure per ASTM B117 (scribed specimen).
7. Unit shall be designed in accordance with ISO 9001, and shall be manufactured in a facility registered by ISO 9001:2015.
8. Roof curb shall be designed to conform to NRCA Standards.
9. Unit shall be subjected to a completely automated run test on the assembly line. The data for each unit will be stored at the factory, and must be available upon request.
10. Unit shall be designed in accordance with UL Standard 60335-1 and 60335-2-40, including testing to withstand rain. Unit shall be IPX4 rated.
11. Unit shall be constructed to prevent intrusion of snow and tested to prevent snow intrusion into the control box up to 40 mph.
12. Unit shall be tested to assurance level 1, ASTM D4169 to ensure shipping reliability.

(2381 19.13.C.) Delivery, Storage, and Handling:

1. Unit shall be stored and handled per manufacturer's recommendations.

## Guide Specification for RTU HP - 25 Ton

Project: FL1B  
Prepared By: Jeff Gries

08/01/2025  
02:33PM

2. Lifted by crane requires either shipping top panel or spreader bars.
3. Unit shall only be stored or positioned in the upright position.

(2381 19.13.D.) Project Conditions:

1. As specified in the contract.

(2381 19.13.E.) Operating Characteristics:

1. Unit shall be capable of starting and running at 125°F (46°C) ambient outdoor temperature, meeting maximum load criteria of AHRI Standard 340/360 at ±10% voltage.
2. Compressor with standard controls shall be capable of operation down to 40°F (4°C), ambient outdoor temperatures in cooling mode.
3. Compressor with standard controls shall be capable of operation down to -10°F (-3.9°C) ambient outdoor temperatures or lower in heat pump heating mode.
4. Unit shall discharge supply air vertically or horizontally as shown on contract drawings.
5. Unit shall be factory configured for either vertical or horizontal supply and return configurations. Unit shall not require field conversion.

(2381 19.13.F.) Electrical Requirements:

1. Main power supply voltage, phase, and frequency must match those required by the manufacturer.

(2381 19.13.G.) Unit Cabinet:

1. Unit cabinet shall be constructed of galvanized steel, and shall be bonderized and coated with a prepainted baked enamel finish on all externally exposed surfaces.
2. Unit cabinet exterior paint shall be: film thickness, (dry) 0.003 inches minimum, gloss (per ASTM D523, 60°F/16°C): 60, Hardness: H-2H Pencil hardness.
3. Evaporator fan compartment interior cabinet insulation shall conform to AHRI Standards 340/360 minimum exterior sweat criteria. Interior surfaces shall be insulated with a minimum 1/2 in. thick, 1 lb density, flexible fiberglass insulation, neoprene coated on the air side. Aluminum foil-faced fiberglass insulation shall be used in the heat compartment.
4. Base of unit shall have a minimum of 4 locations for thru-the-base gas and electrical connections (factory-installed or field-installed), standard.

5. Base Rail:

- a. Unit shall have base rails on a minimum of 2 sides.
- b. Holes shall be provided in the base rails for rigging shackles to facilitate maneuvering and overhead rigging.
- c. Holes shall be provided in the base rail for moving the rooftop by fork truck.
- d. Base rail shall be a minimum of 16 gauge thickness.

6. Condensate pan and connections:

- a. Shall be a sloped condensate drain pan made of a corrosion resistant material.
- b. Shall comply with ASHRAE Standard 62.
- c. Shall use a 3/4 in. 14 NPT drain connection, through the side of the drain pan. Connection shall be made per manufacturer's recommendations.

7. Top panel:

- a. Shall be a multi-top panel linked with watertight flanges and locking systems.

8. Electrical Connections:

- a. All unit power wiring shall enter unit cabinet at a single, factory prepared, knockout location.

## Guide Specification for RTU HP - 25 Ton

Project: FL1B  
Prepared By: Jeff Gries

08/01/2025  
02:33PM

b. Thru-the-base capability.

- 1) Thru-the-base provisions/connections are available as standard with every unit. When bottom connections are required, field furnished couplings are required.
- 2) No basepan penetration, other than those authorized by the manufacturer, is permitted.

9. Component access panels (standard):

- a. Cabinet panels shall be easily removable for servicing.
- b. Unit shall have one factory installed, tool-less, removable, filter access panel.
- c. Panels covering control box, indoor fan, indoor fan motor, gas components (where applicable), and compressors shall have molded composite handles.
- d. Handles shall be UV modified, composite. They shall be permanently attached, and recessed into the panel.
- e. Screws on the vertical portion of all removable access panel shall engage into heat resistant, molded composite collars.
- f. Collars shall be removable and easily replaceable using manufacturer recommended parts.

H.(2381 19.13.1.) Coils:

1. Standard Aluminum Fin-Copper Tube Coils:

- a. Standard evaporator and condenser coils shall have aluminum lanced plate fins mechanically bonded to seamless internally helical grooved copper tubes with all joints brazed.
- b. Evaporator coils shall be leak tested to 150 psig, pressure tested to 450 psig, and qualified to UL 60335-2-40 burst test at 1775 psig.
- c. Condenser coils shall be leak tested to 150 psig, pressure tested to 650 psig, and qualified to UL 60335-2-40 burst test at 1980 psig.

2. Optional Pre-coated aluminum-fin condenser coils:

- a. Shall have a durable epoxy-phenolic coating to provide protection in mildly corrosive coastal environments.
- b. Coating shall be applied to the aluminum fin stock prior to the fin stamping process to create an inert barrier between the aluminum fin and copper tube.
- c. Epoxy-phenolic barrier shall minimize galvanic action between dissimilar metals.
- d. Corrosion durability of fin stock shall be confirmed through testing to be no less than 1000 hours salt spray per ASTM B117.
- e. Corrosion durability of fin stock shall be confirmed through testing to have no visible corrosion after 48 hour immersion in a room temperature solution of 5% salt, 1% acetic acid.
- f. Fin stock coating shall pass 2000 hours of the following: one week exposure in the prohesion chamber followed by one week of accelerated ultraviolet light testing. Prohesion chamber: the solution shall contain 3.5% sodium chloride and 0.35% ammonium sulfate. The exposure cycle is one hour of salt fog application at ambient followed by one hour drying at 95°F (35°C).

3. Optional Copper-fin evaporator and condenser coils:

- a. Shall be constructed of copper fins mechanically bonded to copper tubes and copper tube sheets.
- b. Galvanized steel tube sheets shall not be acceptable.
- c. A polymer strip shall prevent coil assembly from contacting the sheet metal coil pan to minimize potential for galvanic corrosion between coil and pan.

4. Optional E-coated aluminum-fin evaporator and condenser coils:

- a. Shall have a flexible epoxy polymer coating uniformly applied to all coil surface areas without material bridging between fins.

## Guide Specification for RTU HP - 25 Ton

Project: FL1B  
Prepared By: Jeff Gries

08/01/2025  
02:33PM

- b. Coating process shall ensure complete coil encapsulation of tubes, fins and headers.
- c. Color shall be high gloss black with gloss per ASTM D523.
- d. Uniform dry film thickness from 0.8 to 1.2 mil on all surface areas including fin edges.
- e. Superior hardness characteristics of 2H per ASTM D3363 and cross-hatch adhesion of 4B-5B per ASTM D3359.
- f. Impact resistance shall be up to 160 in. lb (ASTM D2794).
- g. Humidity and water immersion resistance shall be up to minimum 1000 and 250 hours respectively (ASTM D2247 and ASTM D870).
- h. Corrosion durability shall be confirmed through testing to be no less than 1000 hours salt spray per ASTM B117.

### I.(2381 19.13.J.) Refrigerant Components:

#### 1.Refrigerant circuit shall include the following control, safety, and maintenance features:

- a. Thermostatic Expansion Valve (TXV) shall help provide optimum performance across the entire operating range. Shall contain removable power element to allow change out of power element and bulb without removing the valve body.
- b. Refrigerant filter drier — Solid core design with pre and post filter service gauge connections for filter diagnostics and maintenance
- c. Service gauge connections on suction and discharge lines.
- d. Pressure gauge access through a specially designed access port in the unit.

#### 2. There shall be gauge line access port in the skin of the rooftop, covered by a black, removable plug.

- a. The plug shall be easy to remove and replace.
- b. When the plug is removed, the gauge access port shall enable maintenance personnel to route their pressure gauge lines.
- c. This gauge access port shall facilitate correct and accurate condenser pressure readings by enabling the reading with the compressor access panel on.
- d. The plug shall be made of a leak proof, UV-resistant, composite material.

#### 3.Compressors:

- a. Unit shall use tandem scroll compressor assembly on a single refrigeration circuit with two stages of cooling for efficient comfort cooling operation.
- b. Evaporator coils shall be a full active design to help better control latent removal and minimize unconditioned bypass air.
- c. Compressor motors shall be cooled by refrigerant gas passing through motor windings.
- d. Compressors shall be internally protected from high discharge temperature conditions.
- e. Compressors shall be protected from an over-temperature and over-ampereage conditions by an internal, motor overload device.
- f. Compressor shall be factory-mounted on rubber grommets.
- g. Compressor motors shall have internal line break thermal, current overload and high pressure differential protection.
- h. Crankcase heaters shall not be required for normal operating range, unless required by the manufacturer due to refrigerant charge limits.

### J.(2381 19.13.K.) Filter Section:

- 1.Filters access is specified in the unit cabinet section of this specification.
- 2. Filters shall be held in place by a pivoting filter tray, facilitating easy removal and installation.

## Guide Specification for RTU HP - 25 Ton

Project: FL1B  
Prepared By: Jeff Gries

08/01/2025  
02:33PM

3. Shall consist of factory installed, low velocity, throw-away 2 in. thick fiberglass filters.
4. Filters shall be standard, commercially available sizes.
5. Only one size filter per unit is allowed.

### K.(2381 19.13.L.) Evaporator Fan and Motor with EcoBlue™ Technology:

#### 1.Direct Drive Evaporator fan motor:

- a. Shall be an ECM motor design.
- b. Shall be direct drive design for all static options.
- c. Shall have permanently lubricated bearings.
- d. Shall have inherent automatic-reset thermal overload protection.
- e. Shall have slow ramp up to speed capabilities.
- f. Shall require no fan/motor belts for operation, adjustments and or initial fan speed setup.
- g. Fan DC voltage set up on Unit Control Board shall eliminate the need of removal of blower access door, required on conventional belt drive systems.
- h. Shall be internally protected from electrical phase reversal.

#### 2.Evaporator Fan:

- a. Speed shall be easily set with dedicated selection switch and adjustment pot on unit control board or through SystemVu™ controller.
- b. Shall provide 2 stage cooling capacity control, the indoor fan speed is automatically controlled to meet the code-compliant low fan speed and 100% at full fan speed operation.
- c. Blower fan shall be a Vane Axial fan design with fan assembly secured directly to ECM motor. Additional shafts, belts, pulleys/sheaves, and bearing blocks to drive fan shall not be permitted or necessary.
- d. Additional variable frequency drive to control fan motor speed shall not be permitted or necessary. All speed control electronics must be onboard fan motor assembly.
- e. Shall be constructed of a cast aluminum stator and high impact composite material on rotor and air inlet casing.
- f. Shall be a patented/pending design with a corrosion resistant material.
- g. Fan assembly design shall be integrated to fan deck, dynamically balanced, and require no additional vibration isolation for normal operation.
- h. Shall have slow ramp up to speed capabilities to help reduce sound and comfort issues typically associated with single speed belt drive systems.
- i. Units shall contain 2 separate vane axial fan assemblies.
- j. Shall be a slide out design with removal of a few support brackets.

3.Shall include an easily accessible Unit Control Board to conveniently and safely provide connection points for vital control functions such as: smoke detectors, phase monitor, gas controller, economizer, thermostat, DDC control options, and low and high pressure switches. Controller shall also provide an intuitive means to adjust the indoor fan speed through a simple switch and pot adjustment design.

### L.(2381 19.13.M.) Condenser Fans and Motors:

#### 1.Condenser fan motors:

- a. Shall be a totally enclosed motor.
- b. Shall use permanently lubricated bearings.
- c. Shall have inherent thermal overload protection with an automatic reset feature.
- d. Shall use a shaft-down design on all sizes.

## Guide Specification for RTU HP - 25 Ton

Project: FL1B  
Prepared By: Jeff Gries

08/01/2025  
02:33PM

### 2. Condenser Fans:

- a. Shall be a direct-driven propeller type fan.
- b. Shall have galvalum blades riveted to steel spider that have corrosion-resistant properties and shall be dynamically balanced.

### M. (2381 19.13.N.) Special Features Options and Accessories:

#### 1. Integrated Economizer ONE and EconoMiSer® 2 low leak rate models.

- a. Integrated, gear driven opposing modulating blade design type capable of simultaneous economizer and compressor operation.
- b. Independent modules for vertical or horizontal return configuration shall be available. Vertical return modules shall be available as a factory installed option.
- c. Damper blades shall be galvanized steel with composite gears. Plastic or composite blades on intake or return shall not be acceptable.
- d. Shall include all hardware and controls to provide free cooling with outdoor air when temperature and/or humidity are below setpoints.
- e. Shall be equipped with gear driven dampers for both the outdoor ventilation air and the return air for positive air stream control.
- f. Low leak rate shall be equipped with dampers not to exceed 2% leakage at 1 in. wg pressure differential.
- g. Economizer controller on EconoMiSer® 2 models shall be the Siemens POL224 that provides:
  - 1) Combined minimum and DCV maximum damper position potentiometers with compressor staging relay.
  - 2) Optional configuration via WLAN stick and Siemens Climatix™ smartphone app for easy setup.
  - 3) Functions with solid-state analog enthalpy or dry bulb changeover control sensing.
  - 4) LED indication for free cooling, sensor, and damper operation.
  - 5) One-line LCD interface screen for setup, configuration and troubleshooting.
  - 6) On-board Fault Detection and Diagnostics (FDD) that senses and alerts when the economizer is not operating properly, per California Title 24, ASHRAE 90.1 and IECC®.
  - 7) Sensor failure loss of communication identification.
  - 8) Capabilities for use with multiple-speed or single speed indoor fan systems.
  - 9) Digital sensors: Dry bulb and Enthalpy.
- h. Economizer controller on EconoMiSer® 2 models with SystemVu controllers shall be a 4-20mA design controlled directly by the controller. SystemVu controllers meet California Title 24, ASHRAE 90.1 and IECC Fault Detection and Diagnostic (FDD) requirements.
- i. Shall be capable of introducing up to 100% outdoor air.
- j. Shall be equipped with a barometric relief damper capable of relieving up to 100% return air and contain seals that meet ASHRAE 90.1 requirements.
- k. Shall be designed to close damper(s) during loss-of-power situations with spring return built into motor.
- l. Dry bulb outdoor air temperature sensor shall be provided as standard. Enthalpy sensor is also available on factory installed only. Outdoor air sensor set point shall be adjustable and shall range from 40°F to 100°F (4°C to 38°C). Additional sensor options shall be available as accessories.
- m. The economizer controller shall also provide control of an accessory power exhaust unit function. Factory set at 100%, with a range of 0% to 100%.

## Guide Specification for RTU HP - 25 Ton

Project: FL1B  
Prepared By: Jeff Gries

08/01/2025  
02:33PM

- n. The economizer shall maintain minimum airflow into the building during occupied period and provide design ventilation rate for full occupancy.
- o. Dampers shall be completely closed when the unit is in the unoccupied mode.
- p. Economizer controller shall accept a 0 to 10 vdc CO<sub>2</sub> sensor input for IAQ/DCV control. In this mode, dampers shall modulate the outdoor air damper to provide ventilation based on the sensor input.
- q. Compressor lockout temperature on POL224 control is adjustable from -45°F to 80°F (-43 to 26°C), set at a factory default of 32°F (0°C).
- r. Actuator shall be direct coupled to economizer gear. No linkage arms or control rods shall be acceptable.
- s. Contains LED indication for free cooling, sensor, and damper operation.

### 2. Integrated Economizer ONE and EconoMiSer® 2 Ultra Low Leak rate models.

- a. Integrated, gear driven opposing modulating blade design type capable of simultaneous economizer and compressor operation.
- b. Independent modules for vertical or horizontal return configuration shall be available. Vertical return modules shall be available as a factory-installed option.
- c. Damper blades shall be galvanized steel with composite gears. Plastic or composite blades on intake or return shall not be acceptable.
- d. Shall include all hardware and controls to provide free cooling with outdoor air when temperature and/or humidity are below setpoints.
- e. Shall be equipped with gear driven dampers for both the outdoor ventilation air and the return air for positive air stream control.
- f. Ultra Low Leak design meets California Title 24 section 140.4 and ASHRAE 90.1 requirements for 4 cfm per sq ft on the outside air dampers and 10 cfm per sq ft on the return dampers.
- g. Economizer controller on EconoMiSer ONE models shall be the Siemens POL224 that provides:
  - 1) One-line LCD interface screen for setup, configuration and troubleshooting.
  - 2) Optional configuration via WLAN stick and Siemens Climatix™ smartphone app for easy setup.
  - 3) On-board Fault Detection and Diagnostics (FDD) that senses and alerts when the economizer is not operating properly, per California Title 24, ASHRAE 90.1 and IECC.
  - 4) Sensor failure loss of communication identification.
  - 5) Capabilities for use with multiple-speed indoor fan systems.
  - 6) Digital sensors: Dry bulb and Enthalpy.
- h. Economizer controller on EconoMiSer® 2 models with SystemVu controls shall be a 4 to 20mA design controlled directly by the controller. SystemVu meet California Title 24, ASHRAE 90.1 and IECC Fault Detection and Diagnostic (FDD) requirements.
- i. Shall be capable of introducing up to 100% outdoor air.
- j. Shall be equipped with a barometric relief damper capable of relieving up to 100% return air and contain seals that meet ASHRAE 90.1 requirements.
- k. Shall be designed to close damper(s) during loss-of-power situations with spring return built into motor.
- l. Dry bulb outdoor air temperature sensor shall be provided as standard. Enthalpy sensor is also available on factory installed only. Outdoor air sensor set point shall be adjustable and shall range from 40°F to 100°F (4°C to 38°C). Additional sensor options shall be available as accessories.
- m. The economizer controller shall also provide control of an accessory power exhaust unit function. Factory set at 100%, with a range of 0% to 100%.

## Guide Specification for RTU HP - 25 Ton

Project: FL1B  
Prepared By: Jeff Gries

08/01/2025  
02:33PM

- n. The economizer shall maintain minimum airflow into the building during occupied period and provide design ventilation rate for full occupancy.
- o. Dampers shall be completely closed when the unit is in the unoccupied mode.
- p. Economizer controller shall accept a 0 to 10 vdc CO<sub>2</sub> sensor input for IAQ/DCV control. In this mode, dampers shall modulate the outdoor air damper to provide ventilation based on the sensor input.
- q. Compressor lockout temperature on POL224 control is adjustable from -45°F to 80°F (-43 to 26°C), set at a factory default of 32°F (0°C).
- r. Actuator shall be direct coupled to economizer gear. No linkage arms or control rods shall be acceptable.
- s. Contains LED indication for free cooling, sensor, and damper operation.

### 3. Wi-Fi/WLAN stick for Economizer ONE POL224 (field-installed):

This item allows use of the Siemens Climatix™ mobile application.

### 4. Two-Position Damper (Field-installed only):

- a. Damper shall be a Two-Position Damper. Damper travel shall be from the full closed position to the field adjustable %-open set-point.
- b. Damper shall include adjustable damper travel from 25% to 100% (full open).
- c. Damper shall include single or dual blade, gear driven dampers and actuator motor.
- d. Actuator shall be direct coupled to damper gear. No linkage arms or control rods shall be acceptable.
- e. Damper will admit up to 100% outdoor air for applicable rooftop units.
- f. Damper shall close upon indoor (evaporator) fan shutoff and/or loss of power.
- g. The damper actuator shall plug into the rooftop unit's wiring harness plug. No hard wiring shall be required.
- h. Outside air hood shall include aluminum water entrainment filter.

### 5. Manual damper (Field-installed only):

Manual damper package shall consist of damper, air inlet screen, and rain hood which can be preset to admit up to 25 or 50% outdoor air for year round ventilation.

### 6. Low Ambient Control Package:

- a. Controller shall control coil head pressure by condenser fan speed modulation or condenser fan cycling and wind baffles.
- b. Shall consist of solid-state control and condenser coil temperature sensor to maintain condensing temperature between 90°F (32°C) and 110°F (43°C) at outdoor ambient temperatures down to -20°F (-29°C). For full low ambient control range, winter start kit is required.

### 7. Condenser Coil Hail Guard Assembly (Factory or field installed)

- a. Shall protect against hail and additional coil damage.
- b. Shall be louvered type

### 8. Unit-Mounted, Non-Fused Disconnect Switch

- a. Available on 15 to 25 ton units with FLA of 100 amps or less (460/575V) or 200 amps or less (208/230V)
- b. Switch shall be factory installed, internally mounted.
- c. National Electric Code (NEC) and UL approved non-fused switch shall provide unit power shutoff.
- d. Shall be accessible from outside the unit.
- e. Shall provide local shutdown and lockout capability.
- f. Sized **only** for the unit as ordered from the factory. Does not accommodate field-installed devices.

### 9. Convenience Outlet:

- a. Factory Installed Powered convenience outlet.
  - 1) Outlet shall be powered from main line power to the rooftop unit.
  - 2) Outlet shall be powered from line side or load side of disconnect by installing contractor, as required by code. If outlet is powered from load side of disconnect, unit electrical ratings shall be UL certified and rated for additional outlet amperage.
  - 3) Outlet shall be factory-installed and internally mounted with easily accessible 115-v female receptacle.
  - 4) Outlet shall include 15 amp GFI receptacles with independent fuse protection.
  - 5) Voltage required to operate convenience outlet shall be provided by a factory installed step-down transformer.
  - 6) Outlet shall be accessible from outside the unit.
  - 7) Outlet shall include a field installed "Wet in Use" cover.
- b. Factory-Installed Non-Powered convenience outlet.
  - 1) Outlet shall be powered from a separate 115/120v power source.
  - 2) A transformer shall not be included.
  - 3) Outlet shall be factory-installed and internally mounted with easily accessible 115-v female receptacle.
  - 4) Outlet shall include 15 amp GFI receptacles with independent fuse protection.
  - 5) Outlet shall be accessible from outside the unit.
  - 6) Outlet shall include a field installed "Wet in Use" cover.
- c. Field-Installed Non-Powered convenience outlet.
  - 1) Outlet shall be powered from a separate 115/120v power source.
  - 2) A transformer shall not be included.
  - 3) Outlet shall be field-installed and internally mounted with easily accessible 115-v female receptacle.
  - 4) Outlet shall include 20 amp GFI receptacles. This kit provides a flexible installation method which allows code compliance for height requirements of the GFCI outlet from the finished roof surface as well as the capability to relocate the outlet to a more convenient location.
  - 5) Outlet shall be accessible from outside the unit.
  - 6) Outlet shall include a field installed "Wet in Use" cover.

### 10. Thru-the-Base Connectors:

- a. Kits shall provide connectors to permit gas and electrical connections to be brought to the unit through the unit basepan.
- b. Minimum of 4 connection locations per unit.

## 11. Centrifugal Power Exhaust:

- a. Power exhaust shall be used in conjunction with an integrated economizer.
- b. Independent modules for vertical or horizontal return configurations shall be available.
- c. Horizontal power exhaust shall be mounted in return ductwork.
- d. Power exhaust shall be controlled by economizer controller operation. Exhaust fans shall be energized when dampers open past the 0 to 100% adjustable setpoint on the economizer control.

## 12. Roof Curbs (Vertical):

- a. Full perimeter roof curb with exhaust capability providing separate air streams for energy recovery from the exhaust air without supply air contamination.
- b. Formed galvanized steel with wood nailer strip and shall be capable of supporting entire unit weight.
- c. Permits installation and securing of ductwork to curb prior to mounting unit on the curb.

## 13. Outdoor Air Enthalpy Sensor:

The outdoor air enthalpy sensor shall be used to provide single enthalpy control. When used in conjunction with a return air enthalpy sensor, the unit will provide differential enthalpy control. The sensor allows the unit to determine if outside air is suitable for free cooling.

## 14. Return Air Enthalpy Sensor:

The return air enthalpy sensor shall be used in conjunction with an outdoor air enthalpy sensor to provide differential enthalpy control.

## 15. Indoor Air Quality (CO<sub>2</sub>) Sensor:

- a. Shall be able to provide demand ventilation indoor air quality (IAQ) control.
- b. The IAQ sensor shall be available in duct mount, wall mount, or wall mount with LED display. The setpoint shall have adjustment capability.

## 16. Smoke detectors:

- a. Shall be a 4-Wire Controller and Detector.
- b. Shall be environmental compensated with differential sensing for reliable, stable, and drift-free sensitivity.
- c. Shall use magnet-activated test/reset sensor switches.
- d. Shall have tool-less connection terminal access.
- e. Shall have a recessed momentary switch for testing and resetting the detector.
- f. Controller shall include:
  - 1) One set of normally open alarm initiation contacts for connection to an initiating device circuit on a fire alarm control panel.
  - 2) Two Form-C auxiliary alarm relays for interface with rooftop unit or other equipment.
  - 3) One Form-C supervision (trouble) relay to control the operation of the Trouble LED on a remote test/reset station.
  - 4) Capable of direct connection to 2 individual detector modules.
  - 5) Can be wired to up to 14 other duct smoke detectors for multiple fan shutdown applications.

## 17. Winter Start Kit:

- a. Shall contain a bypass device around the low pressure switch.
- b. Shall be required when mechanical cooling is required below 40°F (4°C).

## Guide Specification for RTU HP - 25 Ton

Project: FL1B  
Prepared By: Jeff Gries

08/01/2025  
02:33PM

- c. Shall not be required to operate an economizer for cooling when below an outdoor ambient of 40°F (4°C).
- d. Is not compatible with SystemVu controls

### 18. Time Guard:

- a. Shall prevent compressor short-cycling by providing a 5-minute delay ( $\pm 2$  minutes) before restarting a compressor after shutdown for any reason.
- b. One device shall be required per compressor.

### 19. Hinged Access Panels:

- a. Shall provide easy access through integrated quarter turn latches.
- b. Shall be on major panels of: filter, control box, fan motor, and compressor.

### 20. Condensate overflow switch:

This sensor and related controller monitors the condensate level in the drain pan and shuts down compression operation when overflow conditions occur. It includes:

- a. Indicator light — solid red (more than 10 seconds on water contact — compressors disabled), blinking red (sensor disconnected).
- b. 10 second delay to break — eliminates nuisance trips from splashing or waves in pan (sensor needs 10 seconds of constant water contact before tripping).
- c. Disables the compressor(s) operation when condensate plug is detected, but still allows fans to run for Economizer.

### 21. MERV-13 – 4 in. Return Air filters (Factory Installed Only):

- a. Factory option to upgrade standard unit filters to 4" MERV-13 filters
- b. Upgraded option shall include factory installed 4" filter rack

### 22. 4 in. Return Air Rack (Field Installed Only):

- a. Accessory kit is designed to hold 4 in. MERV-8 or MERV-13 filters. Filters not included in kit.

### 23. 2 in. MERV-13 Return Air filters:

- a. Accessory kit to field upgrade standard unit filters to 2 in. MERV-13 filters.
- b. Correct size and quantity of filters shall ship in a single box

### 24. 2 in. MERV-8 Return Air filters:

- a. Accessory kit to field upgrade standard unit filters to 2 in. MERV-8 filters.
- b. Correct size and quantity of filters shall ship in a single box

### 25. Phase Monitor Control:

- a. Shall monitor the sequence of 3-phase electrical system to provide a phase reversal protection.
- b. Shall monitor the 3-phase voltage inputs to provide a phase loss protection for the 3-phase device.
- c. Will work on either a Delta or Wye power connection.

### 26. Horn/Strobe Annunciator:

- a. Provides an audible/visual signaling device for use with factory-installed option or field installed accessory smoke detectors.
- b. Requires installation of a field-supplied 24-v transformer suitable for 4.2 VA (AC) or 3.0 VA (DC) per horn/strobe accessory.
- c. Requires field-supplied electrical box, North American 1-gang box, 2 in. (51 mm) x 4 in. (102 mm).

## Guide Specification for RTU HP - 25 Ton

Project: FL1B  
Prepared By: Jeff Gries

08/01/2025  
02:33PM

- d. Shall have a clear colored lens.

### 27. Electric Heat:

#### a. Heating Section:

- 1) Heater element open coil resistance wire, nickel-chrome alloy, 0.29-in. inside diameter, strung through ceramic insulators mounted on metal frame. Coil ends are staked and welded to terminal screw slots.
- 1) Heater assemblies are provided with integral fusing for protection of internal heater circuits. Auto reset thermo limit controls, magnetic heater contactors (24-v coil) and terminal block all mounted in electric heater control box (minimum 18 ga galvanized steel) attached to end of heater assembly.

### 28. High Short Circuit Current Rating (SCCR) Protection:

- a. Factory-installed option shall provide high short circuit current protection to compressor and all indoor and outdoor fan motors rated at 60 kA (208/230V) or 65kA (460V) against high potential fault current situations. (Standard unit comes with 5 kA rating.)
- b. This option is not available with factory installed powered convenience outlet, Non-Fused Disconnect, Low Ambient controls, Phase loss monitor/protection and 575 Volt models.

# Unit Feature Sheet for RTU HP - 25 Ton

Project: FL1B  
Prepared By: Jeff Gries

08/01/2025  
02:33PM



## PURON ADVANCE™ PACKAGED ROOFTOP ELECTRIC COOLING UNITS WITH OPTIONAL ACCESSORY ELECTRIC HEAT – 15, 20, 25 TONS

50FEQ units are single-packaged heat pump units with optional accessory electric heat. All units are prewired and pre-charged with Carrier's new, low global warming potential Puron Advance™ (R-454B) refrigerant. Puron Advance represents a 75% reduction in refrigerant GWP over legacy Puron™ (R-410A) models. All units are factory tested in both heating and cooling modes and use two stage cooling capacity control.

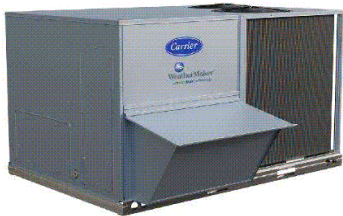

Use of the AHRI Certified™ Mark indicates a manufacturer's participation in the program. For verification of certification for individual products, go to [www.ahridirectory.org](http://www.ahridirectory.org).



### PERFORMANCE FEATURES

- Puron Advance (R-454B) refrigerant
- Two-stage cooling capacity on all models
- IEEERs up to 14.0, COP up to 3.3
- New - A2L leak detection and dissipation system factory installed standard
- Leak system ensures unit and occupant safety during operation and includes an alarm relay for optional use
- Onboard recallable leak detection history for easier troubleshooting and service
- **Direct Drive** – EcoBlue™ Technology Indoor fan system uses Vane Axial fan design and electronically commutated motor
- New Unit Control Board with intuitive quick fan speed adjustment
- Meets or exceeds DOE's stringent 2023 IEER efficiency requirements.
- ASHRAE 90.1 and IECC code compliant
- Copper tube aluminum fin coils with optional coating
- Exclusive non-corrosive composite condensate pans in accordance with ASHRAE 62 Standard, sloping design; side or center drain
- Pre-painted exterior panels and primer-coated interior panels tested to 500 hours salt spray protection
- TXV refrigerant metering system on all models
- Fully insulated cabinet
- Standard cooling operating range up to 125°F (52°C), and down to 40°F (-4°C). Low Ambient kits allows cooling operation down to 0°F (-18°C).
- Rated in accordance with AHRI Standards 340/360
- Designed in accordance with Underwriters' Laboratories Standard UL 60335-1 and UL 60335-2-40
- Listed by UL and CUL-Canada

### MAINTENANCE FEATURES

- Large access panels with easy grip handles
- Innovative, easy starting, no-strip screw feature on unit access panels
- Two-inch disposable return air filters
- Tool-less filter access door
- New Vane Axial evaporator-fan system has no fan belts, pulleys, blower shaft, and blower bearings with slide out design
- Unit control board facilitates simple safety circuit troubleshooting and simplified control box arrangement

### INSTALLATION FEATURES

- Dedicated vertical and horizontal airflow models available – ordered as a factory option. No special kits required.
- Provisions for thru-the-bottom power entry capability
- Single point electric connections
- Full perimeter base rail with built-in rigging adapters and fork truck slots

### STANDARD LIMITED PARTS WARRANTY

- 5-year compressor parts
- 5-year electric heater
- 3-year SystemVu™ controller
- 1-year parts

### AVAILABLE OPTIONS:

- Disconnect and convenience outlet options
- High static motor options
- Smoke detector, supply and/or return air
- Corrosion resistant options for evaporator and condenser coils
- CO2 Sensor
- Phase Monitor Protection
- 4" MERV-13 Filters
- 2-position damper (Field Installed Only)
- Accessory electric heat (field-installed option only)
- Hinged access panels
- Integrated economizer system. Low and ULTRA Low Leak versions.
- Condensate overflow switch
- SystemVu Controls

# Spec Sheet for RTU HP - 25 Ton

Project: FL1B  
Prepared By: Jeff Gries

08/01/2025  
02:33PM