

Medpace B200 Microbiology Renovation  
5365 Medpace Way  
Cincinnati, Ohio 45227

Dedicated Outside Air Unit

Submission Date: 03/29/2024

KLH Engineers  
1538 Alexandria Pike, Ste 11  
Fort Thomas, KY 41075

Medpace  
5665 Medpace Way  
Cincinnati, OH 45227

**ElitAire Account Executive:**

Brett Graham

[bgraham@elitaire.com](mailto:bgraham@elitaire.com)

859-380-4782



Equipment	Startup Services	Labor Warranty	VFDs	Disconnects
RTU-1	YES	1-year	YES	YES

Equipment	Clarifications & Exclusions
RTU-1	<p><b>General</b>  Painted galvanized steel casing with 2,500 hr. salt spray rating  2" double wall construction with R-13 insulation  6" Galvanized steel base rail with integral lifting lugs</p> <p><b>Electrical</b>  Factory installed non-fused disconnect  <b>65kVA high SCCR disconnect</b>  115V convenience outlet (<b>field powered</b>)  Phase and voltage monitor</p> <p><b>Energy Recovery</b>  Low leakage outdoor air damper and intake hood  Enthalpic core plate heat exchanger  Stainless steel drain pan  Electric preheater for economizer frost prevention  2" MERV-8 exhaust and outdoor air filters with dirty filter sensors</p> <p><b>Exhaust Fan</b>  Direct drive plenum fan with neoprene vibration isolation  Factory installed VFD with constant volume control and setpoint adjustment  Motor shaft grounding ring  <b>Exhaust fan airflow monitoring station</b></p> <p><b>Air Source Heatpump</b>  Variable speed inverter driven compressor  2" MERV-8 supply air filters  Stainless steel drain pan with overflow switch  Condensate overflow switch  Modulating hot gas reheat  <b>Supply fan airflow monitoring station</b></p> <p><b>Supplemental Heat</b>  Electric heat  Modulating SCR Control  Integrated Operation with ASHP</p>

**Condenser**

Aluminum micro-channel coils  
Variable speed condenser fan with ECM motor on lead circuit

**Supply Fan**

Direct drive plenum fan with neoprene vibration isolation  
Factory installed VFD with constant volume control with setpoint adjustment  
Motor shaft grounding ring

**Controls**

Factory installed DDC unit controls  
BACnet MSTP integration card  
Dirty filter sensors (outside air, supply air, exhaust air)

**Roof Curb**

14" full perimeter roof curb  
Uninsulated  
Knock-down construction

**Start-up and Warranty**

1-year complete unit parts warranty  
5-year compressor parts warranty

**Exclusions**

Rigging and installation supervision  
Seismic and Wind Calculations

# VXC-212-FH-25A-1-A1

## Unit Performance

Design Conditions						
Elevation (ft)	Summer		Winter DB (F)	Supply (CFM)	Outdoor Air (CFM)	Exhaust Air (CFM)
	DB (F)	WB (F)				
499	92.8	77.9	1.0	6,000	6,000	5,400

Unit Specifications						
Qty	Weight (lb)	Cooling Type	Primary Heating Type	Secondary Heating Type	Unit Installation	Unit ETL Listing
1	5,480 (+/- 5%)	Air-Source Heat Pump	Air-Source Heat Pump	Electric	Outdoor	UL/cUL 1995/60335-2-40

Configuration			
Outdoor Air		Exhaust Air	
Intake	Discharge	Intake	Discharge
End	Bottom	Bottom	Side

ASHRAE 90.1 Compliance			
	ASHRAE 90.1 Min. Efficiency	Calculated Efficiency	Compliance
ISMRE (ASHRAE 90.1-2019)	5.2	5.6	✓
ISMRE2 (ASHRAE 90.1-2022)	5	5.6	✓
ISCOP (ASHRAE 90.1-2019)	3.3	4.4	✓
ISCOP2 (ASHRAE 90.1-2022)	3.2	3.38	✓
Enthalpy Recovery Ratio (%)	50	56.4	✓

Energy Recovery Performance									
Design Condition	Temperature (F)								Capacity Reduction (BTU/h)
	Outdoor Air		Supply Air		Return Air		Exhaust Air		
	DB	WB	DB	WB	DB	WB/RH	DB	WB	
Summer	92.8	77.9	81.6	69.9	75.0	62.5/50	87.4	72.8	202,500.0
Winter	1.0	-0.6	46.0	40.3	72.0	55.7/35	22.3	20.4	291,600.0

Cooling Specifications						
Type	Total Capacity (MBH)	Sensible Capacity (MBH)	Coil (DB/WB)		Reheat	
			EAT (F)	LAT (F)	Capacity (MBH)	LAT (F)
Air-Source Heat Pump	332.0	190.0	81.6 / 69.9	52.8 / 52.6	111.9	70.1

Primary Heat Specifications			
Type	Total Capacity (MBH)	Dry Bulb Temperatures	
		EAT (F)	LAT (F)
Air-Source Heat Pump	141.3	49.3	71.1

Secondary Heat Specifications							
Type	Capacity (kW)	Full Load Amps (FLA)	Capacity Control	Performance (w/ASHP)		Performance (w/o ASHP)	
				EAT (F)	LAT (F)	EAT (F)	LAT (F)
Electric	60.0	75.31	Modulating (SCR)	71.1	102.7	46.0	77.6

Motor Specifications						
Motor	Qty	Operating Power (hp)	Size (hp)	Enclosure	Efficiency	RPM
Supply	1	5.06	7-1/2	ODP	PE	1770
Exhaust	1	3.22	5	ODP	PE	1760

Electrical Specifications						
Power Supply	Rating (V/C/P)	MCA (A)	MOP (A)	FLA (A)	Fan Power (W/CFM)*	



**Printed Date:** 03/29/2024  
**Job:** Medpace Bldg B200  
**Mark:** ERU-1  
**Model:** VXC-212-FH-25A-1-A1

Unit	460/60/3	177.8	200.0	169.8	1.030
------	----------	-------	-------	-------	-------

### Construction Features And Accessories

Unit	
Unit Installation - Outdoor	Std
Unit Construction - Double Wall	Std
Insulation - 2 inch 2.4# R13 foam	Std
Corrosion Resistant Fasteners	Std
Hinged Access	Std
Factory Wired Non-Fused Disconnect Switch	X
Direct Drive Plenum Blower & Motor Assemblies	X
Factory Wired VFDs	Std
Unit Finish - Permatector, Concrete Gray (RAL 7023)	X
Stainless Steel Condensate Drain Pan and Connection	Std
Condensate Drain Trap	Std
Short Circuit Current - 5 kA	Std
Recovery Device - Fiber Membrane Energy Recovery Core	Std
Controls	
Unit Controls - Full Control	Std
Internally Mounted Control Center with 24 VAC control transformer(s) and control circuiting fusing	Std
BMS Protocol - BACNetMSTP	X
BMS Monitoring Points	
Supply Fan Control - Constant Volume-Adj. Setpoint	X
Exhaust Fan Control - Constant Volume-Adj. Setpoint	X
Economizer Control	
Exhaust Fan Only Power	
Web-Based User Interface	Std
Damper Control - 100% OA-No Recirculation	X
Energy Core Economizer Control	
Unoccupied Recirc Mode	
Control Accessories	
Remote Display	
Dirty Filter Sensor(s) - All	X
Airflow Monitor - Exhaust Air, Supply Air	X
Return Duct Sensor - Temp and RH	X
Phase/Brownout Protection	Std
Economizer Fault Detection Diagnostics	

Accessories	
Frost Control Preheater - Electric Preheater	X
Outdoor Air Damper - Low Leakage	X
Return Air Damper	
Roof Curb - GKD - 61.6/190.6-G14	X
Supply Air Filters - 2" Merv 8, 3-16x20x2, 3-20x20x2	Std
Service Outlet - Shipped loose and powered by others	X
Piping Vestibule	
Service Lights	
Condensate Overflow Switch	X
Spare Filters	
Exhaust Discharge Gravity Backdraft Damper	X
ElectroFin Coil Coating	
Motor Shaft Grounding	X
Bipolar Ionization	
Smoke Detector(s)	
Barometric Relief Damper	
UV Lights	
Return Air Filters - 2" Merv 8, 4-16x25x2	Std
Outdoor Air Filters - 2" Merv 8, 4-16x25x2	Std
Furnace Control	
Energy Core Bypass Damper	
Hail Guards	
Warranty Options	
Unit Warranty - 18 Months (Std.)	Std
Compressor Warranty - 5.5 Yrs. (4 Yrs. Extended)	X
Energy Core Warranty - 5 Yrs.	Std

Standard Option	Std
Not Included	
Included	X

Notes
Outdoor Air Damper supplied is low leakage, motorized VCD-23 (leakage rate of 3 CFM/ft <sup>2</sup> @ 1 in. wg), Class 1A
Air-Source Heat Pump heating is locked below 10°F (-12.2°C). Above 10°F (-12.2°C), unit may go into defrost or extended lock out (until weather pattern changes) during high humidity or precipitation events. Without supplemental heat, supply discharge temperature may be extremely low during defrost. To avoid this, consider selecting supplemental heat.

## Special Design Requests

Special Design Number
-----------------------

Special Design Request for "Voltage: Add for 30 kA SCCR", (V2400103)
--

### Supply Fan Charts And Performance

Supply Fan Performance									
Total Volume (CFM)	External SP (in. wg)	Total SP (in. wg)	RPM	Operating Power (hp)	Motor		Fan		
					Qty	Size (hp)	Qty	Type	Drive-Type
6,000	1	3.46	1685	5.06	1	7-1/2	1	Plenum	Direct

Pressure Drop (in. wg)							
Weatherhood	Filter	Damper	Cooling	Heating	External	Energy Core	Total
0.2	0.136	0.06	0.404	0.278	1	1.24	3.46

Sound Performance in Accordance with AMCA										
Sound Power by Octave Band								Lwa	dBA	Sones
62.5	125	250	500	1000	2000	4000	8000			
89	88	96	83	80	73	71	69	89	78	29

\*Core Wheel pressure drop shown in above table also accounts for pressure drop across MERV8 OA filter

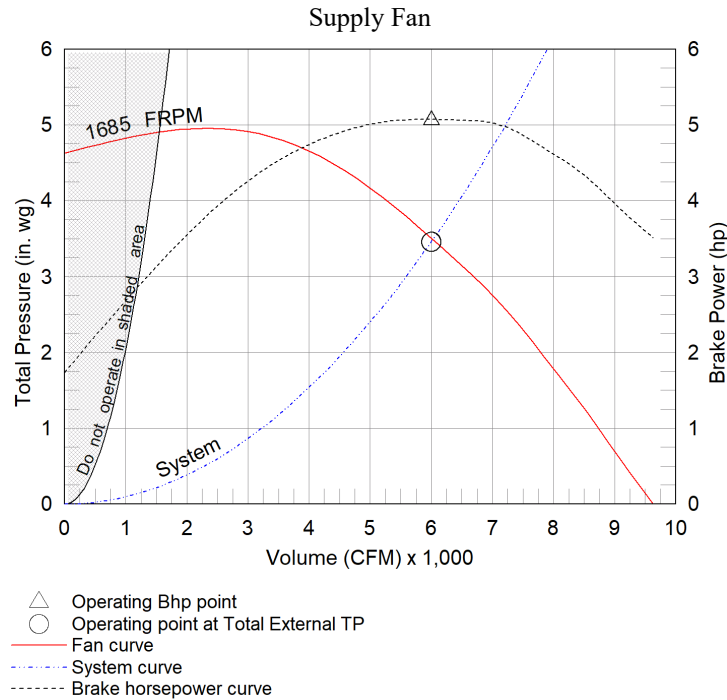

### Exhaust Fan Charts And Performance

Exhaust Fan Performance									
Total Volume (CFM)	External SP (in. wg)	Total SP (in. wg)	RPM	Operating Power (hp)	Motor		Fan		
					Qty	Size (hp)	Qty	Type	Drive-Type
5,400	0.75	2.065	1447	3.22	1	5	1	Plenum	Direct

Pressure Drop (in. wg)							
Weatherhood	Filter	Damper	Cooling	Heating	External	Energy Core	Total
0.07	-	-	-	-	0.75	1.34	2.065

Sound Performance in Accordance with AMCA										
Sound Power by Octave Band								Lwa	dBA	Sones
62.5	125	250	500	1000	2000	4000	8000			
92	83	84	73	67	65	63	63	78	67	17

\*Core Wheel pressure drop shown in above table also accounts for pressure drop across MERV8 return air filter

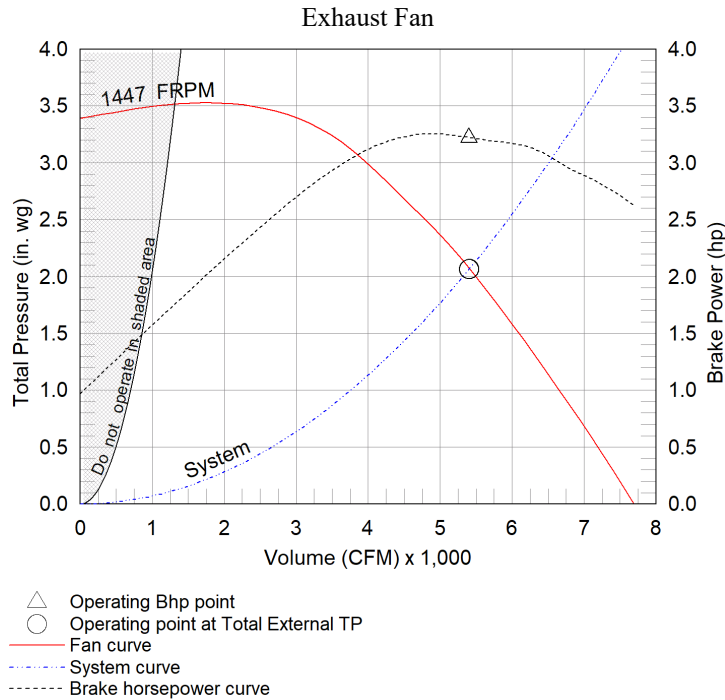

## Radiated Sound

### Position A

Dimensional Overview

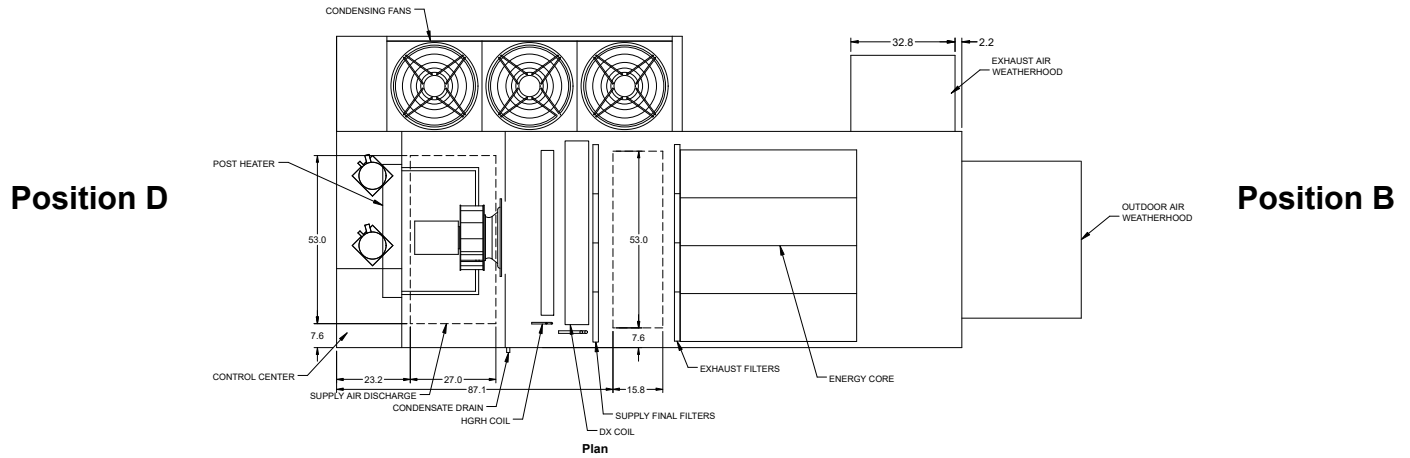

"E" is the Top Plane

Supply Air Flow Nominal, Largest Tonnage Condensing Section Available, PDX units only

Radiated Sound Levels										
Plane	Octave Bands (Lw)								Plane Lw	Plane LwA
	1	2	3	4	5	6	7	8		
A	80	87	82	80	77	72	68	62	90	82
B	74	80	73	67	64	59	55	48	82	71
C	82	77	73	69	67	61	54	46	84	72
D	71	80	74	72	69	63	58	52	82	74
E	77	86	82	78	76	71	66	61	89	81
<b>Total</b>	86	91	86	83	80	75	71	65	94	85

AMCA 320-07 - Laboratory Methods of Sound Testing of Fans Using Sound Intensity
Tests conducted in accordance with this standard.
Free field measurement plane created 1 foot from unit on all sides and top.
Sound Intensity measured in Watts/m <sup>2</sup> .
Sound data converted to Sound Power (Lw) for the chart above.
A-Weighted Sound Power was determined using AMCA Standard 301-90 Clause 9.1.
Plane E sound data was measured above the top plane of the unit.

### Air-Source Heat Pump Performance

Coil Information						
Indoor Coil Model	Fins Per Inch	Rows Deep	Face Vel. (ft/min)	Coil PD (in. wg)	Refrigerant	Face Area (ft <sup>2</sup> )
DX38S06H12-52x56-LH	12	6	297	0.404	R-410A	39

Compressor Details					
Lead Compressor Type	Compressor Qty	Compressor RLA/MRC (A)		Compressor LRA (A)	
		Comp. #1	Comp. #2	Comp. #1	Comp. #2
Inverter Scroll	2	32	18.6	0	125

Cooling Specifications						
Type	Total Capacity (MBH)	Sensible Capacity (MBH)	Coil (DB/WB)		Reheat	
			EAT (F)	LAT (F)	Capacity (MBH)	LAT (F)
Air-Source Heat Pump	332.0	190.0	81.6 / 69.9	52.8 / 52.6	-	-

Primary Heat Specifications				
Type	Total Capacity (MBH)	Dry Bulb Temperatures		
		EAT (F)	LAT (F)	Ambient Outdoor Air (F)
Air-Source Heat Pump	141.3	49.3	71.1	10.0

Unit Details
Refrigerant charges provided by the factory are approximate and may require adjustment in the field
Hermetic scroll type compressors
Compressors mounted on neoprene vibration isolation
Crankcase heater on staged compressor
Electronic expansion valve on lead circuit, thermostatic expansion valve on staged circuit
Stainless steel double sloped drain pan
Moisture-indicating sight glass
Service/charging valves
Refrigerant high pressure switch (manual reset)
Liquid-Line filter drier
Multiple low sound outdoor fans with Lead ECM outdoor fan for modulating head pressure control
Inverter scroll compressor
Refrigerant low pressure switch (auto reset)
Unit cannot be mounted in an enclosed space.

Important Notes:
Air-Source Heat Pump heating is locked below 10°F (-12.2°C). Above 10°F (-12.2°C), unit may go into defrost or extended lock out (until weather pattern changes) during high humidity or precipitation events. Without supplemental heat, supply discharge temperature may be extremely low during defrost. To avoid this, consider selecting supplemental heat.



## Secondary Heat Performance

Secondary Heat Specifications							
Type	Capacity (kW)	Full Load Amps (FLA)	Capacity Control	Performance (w/ASHP)		Performance (w/o ASHP)	
				EAT (F)	LAT (F)	EAT (F)	LAT (F)
Electric	60.0	75.31	Modulating (SCR)	71.1	102.7	46.0	77.6

Unit Details
Open coil heating elements
High grade Nickel-Chrome alloy coils
SCR controller
Unit controller maximum allowable supply discharge air set point is 100F (37.8C)
Heat pump and electric heater can operate simultaneously. Unit MCA/MOP will be sized for concurrent operation of all loads

### Energy Recovery Summer Performance

Design Air Flow Conditions				Outdoor Air Cooling Reduction				
OA Volume (CFM)	ASHRAE 90.1 OA Enthalpy Recovery Ratio	EA Volume (CFM)	EA Core Effectiveness	OA Load w/o Energy Recovery		OA Load with Energy Recovery		Equipment Reduction (tons)
				(BTU/h)	(tons)	(BTU/h)	(tons)	
6,000	56.4	5,400	62.1	361,800.0	30.15	159,300.0	13.28	16.88

<b>Outdoor Air Entering</b>		<p>Total Enthalpy Core</p>	<b>Exhaust Air Leaving</b>	
Dry Bulb (F)	92.8		Dry Bulb (F)	87.4
Wet Bulb (F)	77.9		Wet Bulb (F)	72.8
Specific Humidity (gr/lb)	124		Specific Humidity (gr/lb)	99.1
Enthalpy (BTU/lb)	41.7		Enthalpy (BTU/lb)	36.6
<b>Indoor Air Entering</b>			<b>Supply Air Leaving</b>	
Dry Bulb (F)	75.0		Dry Bulb (F)	81.6
Rel. Humidity (%)	50		Wet Bulb (F)	69.9
Specific Humidity (gr/lb)	66		Specific Humidity (gr/lb)	93
Enthalpy (BTU/lb)	28.3		Enthalpy (BTU/lb)	34.2

### Summer Conditions

- 1 = Outdoor Air Design
- 2 = Energy Core
- 3 = DX Coil
- 4 = Hot Gas Reheat
- 5 = Exhaust Air Entering Core

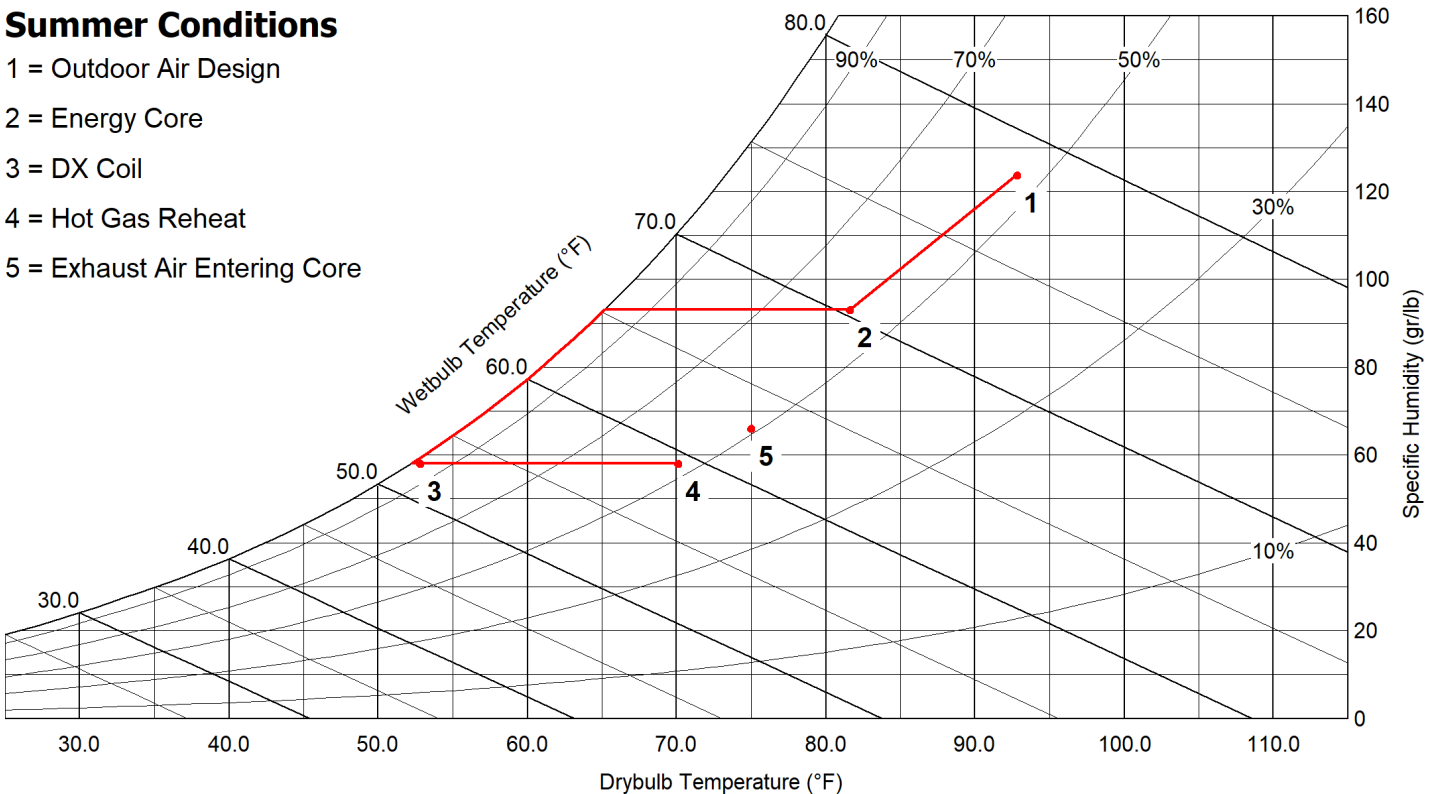

### Energy Recovery Winter Performance w/out Preheater

Outdoor Air		ENERGY WHEEL	Supply Air	
Dry Bulb (F)	1.0		Dry Bulb (F)	46.0
Wet Bulb (F)	-0.6		Wet Bulb (F)	40.3
Specific Humidity (gr/lb)	3		Specific Humidity (gr/lb)	29
Enthalpy (BTU/lb)	0.7	Enthalpy (BTU/lb)	15.5	
Exhaust Air		ENERGY WHEEL	Return Air	
Dry Bulb (F)	22.3		Dry Bulb (F)	72.0
Wet Bulb (F)	20.4		Rel. Humidity (%)	35
Specific Humidity (gr/lb)	13		Specific Humidity (gr/lb)	42
Enthalpy (BTU/lb)	7.3	Enthalpy (BTU/lb)	23.8	

Design Air Flow Conditions			
OA Volume (CFM)	ASHRAE 90.1 OA Enthalpy Recovery Ratio	EA Volume (CFM)	EA Core Effectiveness
6,000	64.1	5,400	70.5

Outdoor Air Heating Reduction			
OA Load w/o Energy Recovery (BTU/h)	OA Load with Energy Recovery (BTU/h)	Equipment Reduction (BTU/h)	Sensible Effectiveness (%)
460,080.0	168,480.0	291,600.0	69.9

### Energy Recovery Winter Performance w/Preheater

Design Air Flow Conditions				Outdoor Air Heating Reduction			
OA Volume (CFM)	ASHRAE 90.1 OA Enthalpy Recovery Ratio	EA Volume (CFM)	EA Core Effectiveness	OA Load w/o Energy Recovery (BTU/h)	OA Load with Energy Recovery (BTU/h)	Equipment Reduction (BTU/h)	Sensible Effectiveness (%)
6,000	64.1	5,400	70.5	460,080.0	168,480.0	291,600.0	69.9

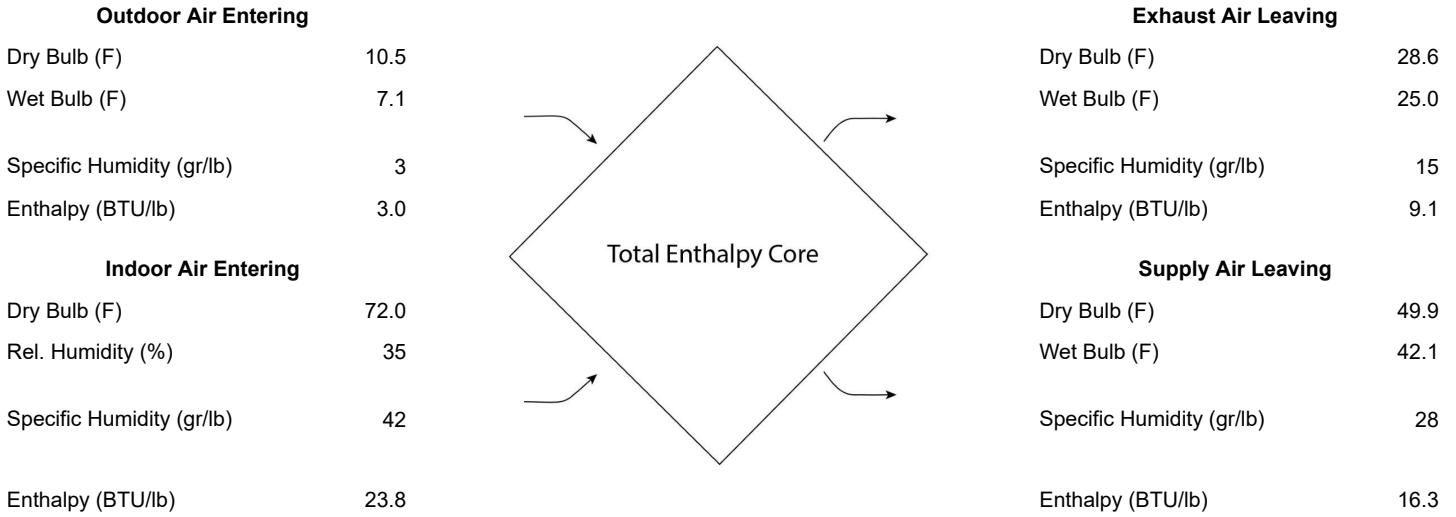

### Winter Conditions

- 1 = Outdoor Air Design
- 2 = Preheater
- 3 = Energy Core
- 4 = Secondary Heating
- 5 = Exhaust Air Entering Core

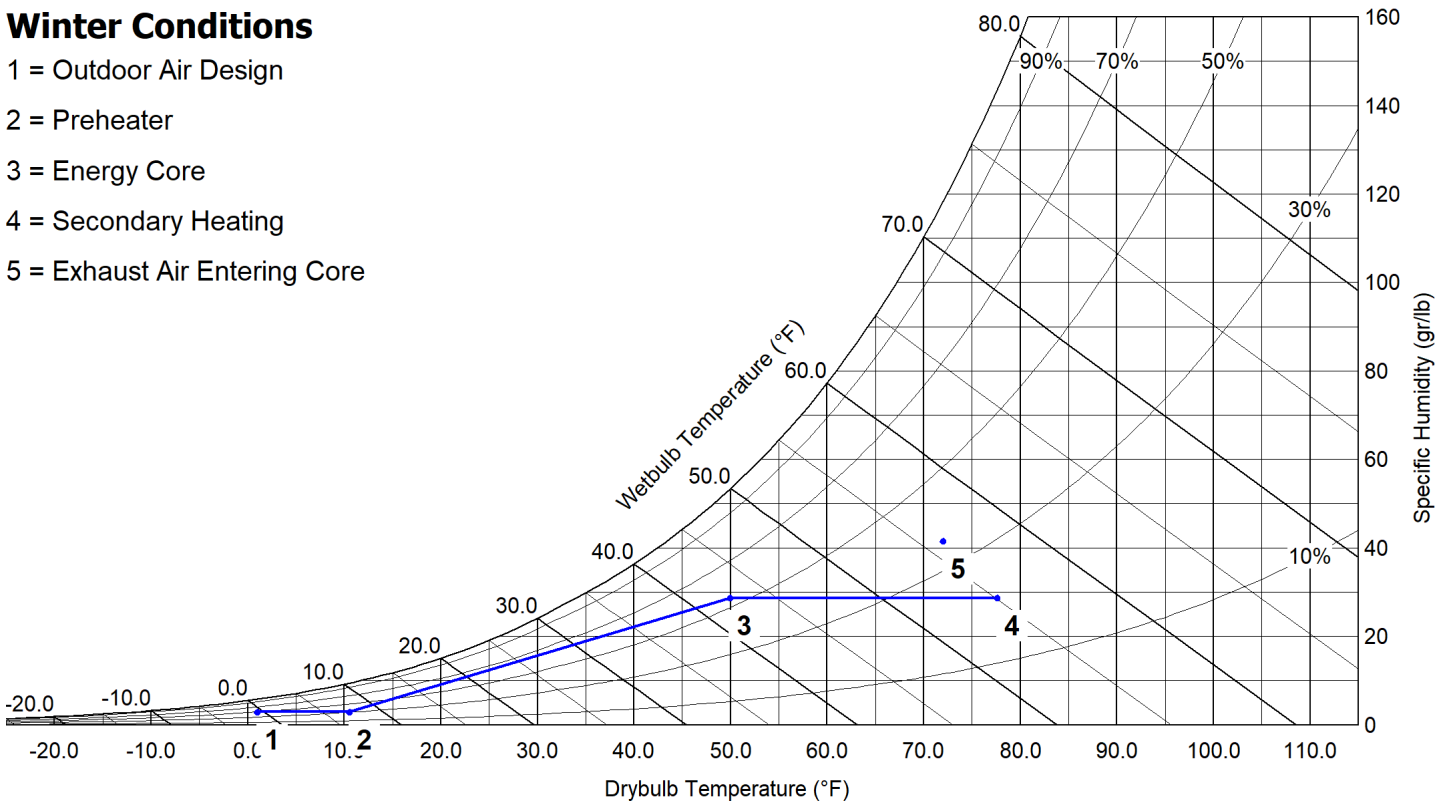

### AHRI Performance Ratings

Energy Recovery Performance Rating in accordance with AHRI Standard 1060 (I-P)						
Rated Airflow (SCFM)		Net Supply Airflow (SCFM)	EATR (%)	OACF	Pressure Drop (in. wg)	
Leaving Supply	Entering Exhaust				Supply	Exhaust
6138	5538	6000	0.6	1.02	1.33	1.18

Thermal Effectiveness Ratings							
Enthalpy Recovery		Sensible Effectiveness		Latent Effectiveness		Total Effectiveness	
Summer	Winter	Summer	Winter	Summer	Winter	Summer	Winter
56.4	64.1	70	69.9	58	73.8	62.1	70.5

**Note(s)**

Summer Design Conditions:  
 Certified in accordance with the AHRI ERV Certification Program, which is based on AHRI Standard 1060. Certified units may be found in the AHRI Directory at [www.ahridirectory.org](http://www.ahridirectory.org).



Winter Design Conditions:  
 Application Rating is outside the scope of the AHRI ERV certification Program but is rated in accordance with AHRI Standard 1060.

### Isometric Drawings

Component Layout

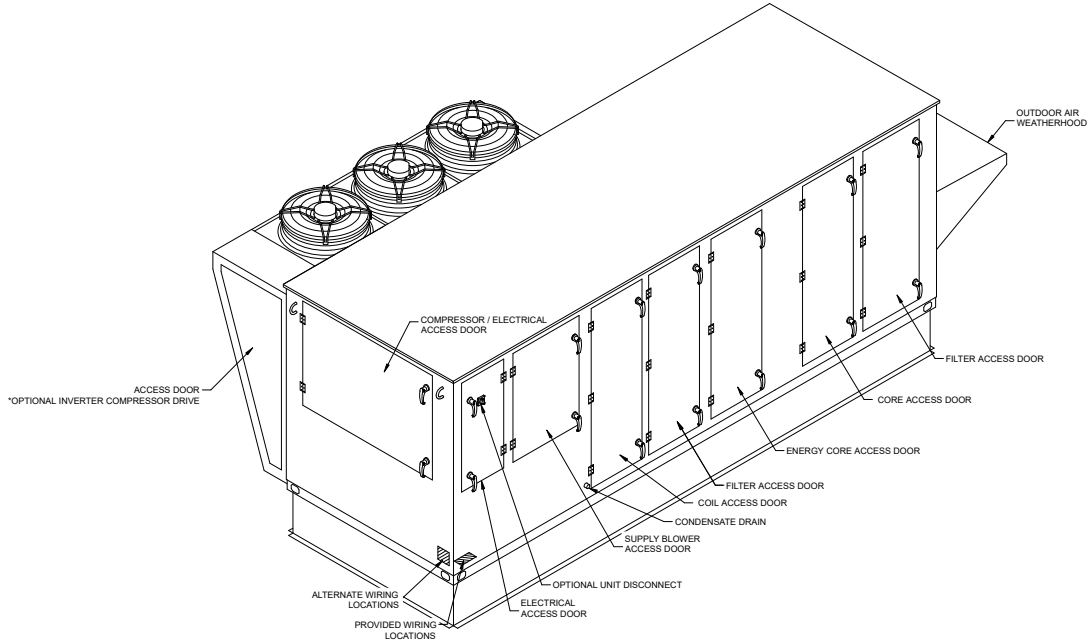

Back Right Isometric

Service Clearances

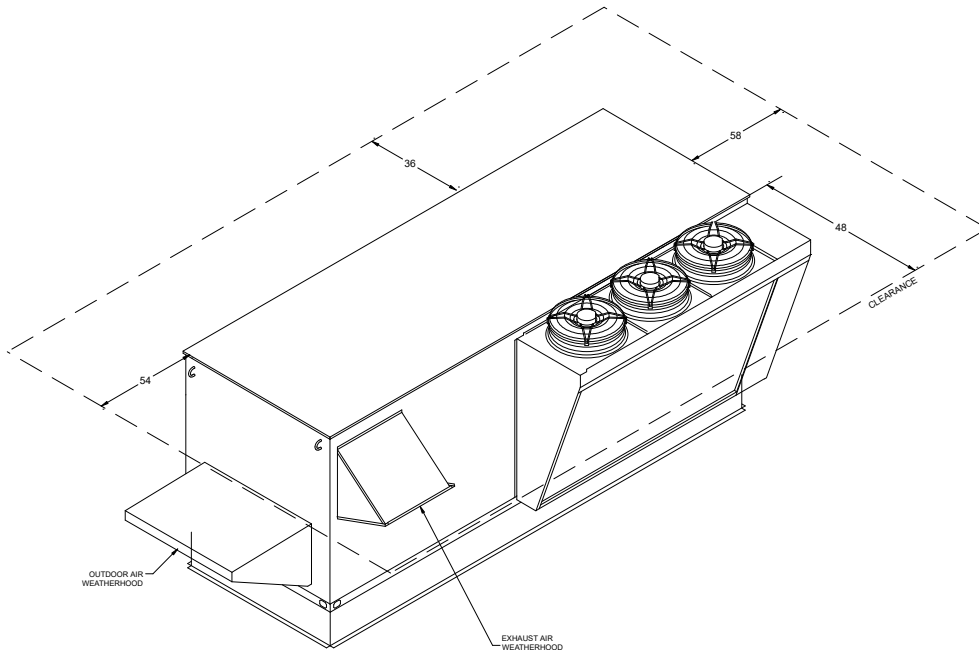

Front Left Isometric

## Overview Drawings

### Electrical Connections

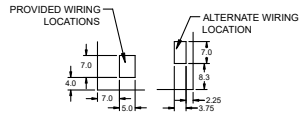

### Dimensional Overview

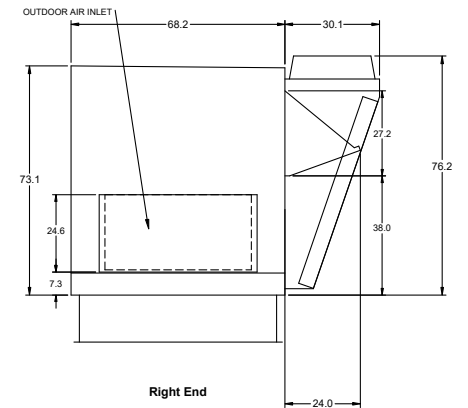
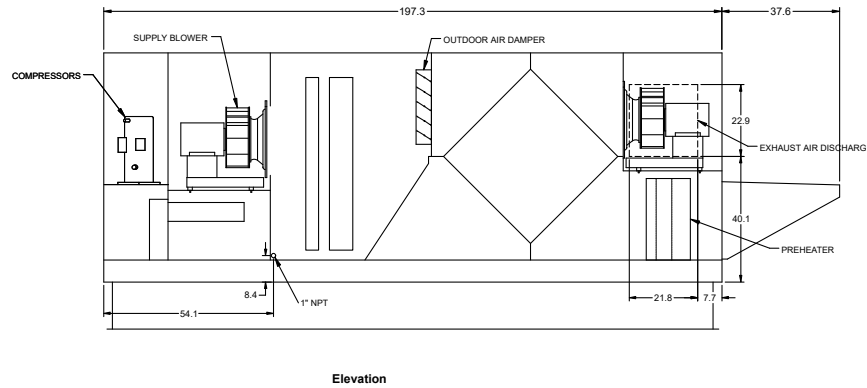
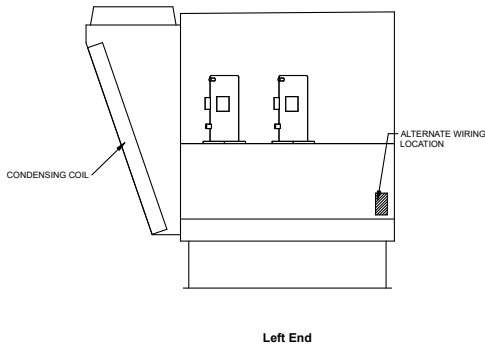
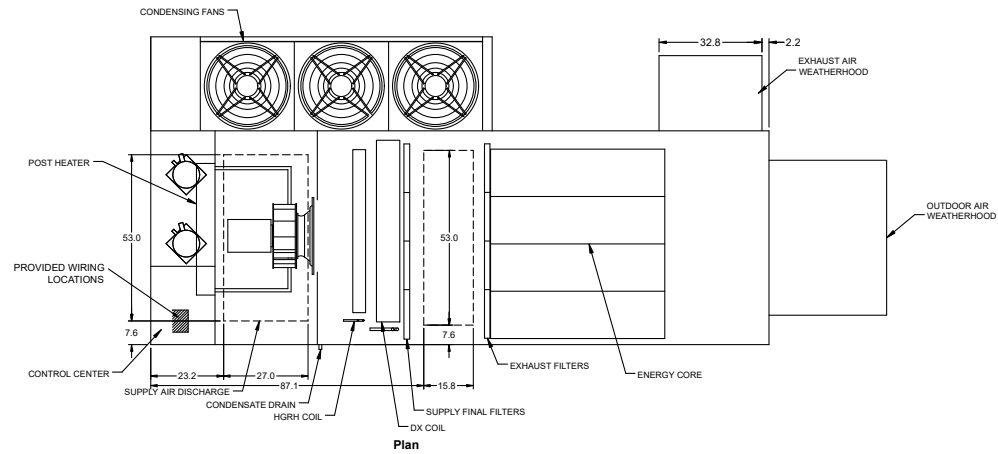

### Unit Corner Weights

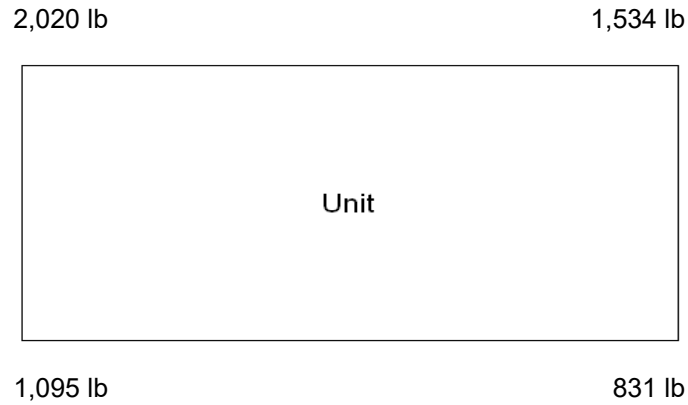

#### Note

Estimated corner weights are shown looking down on unit and the outside air intake will be on the right. Weights are applied at the base of the unit. Images not drawn to scale.

### Wiring Diagram

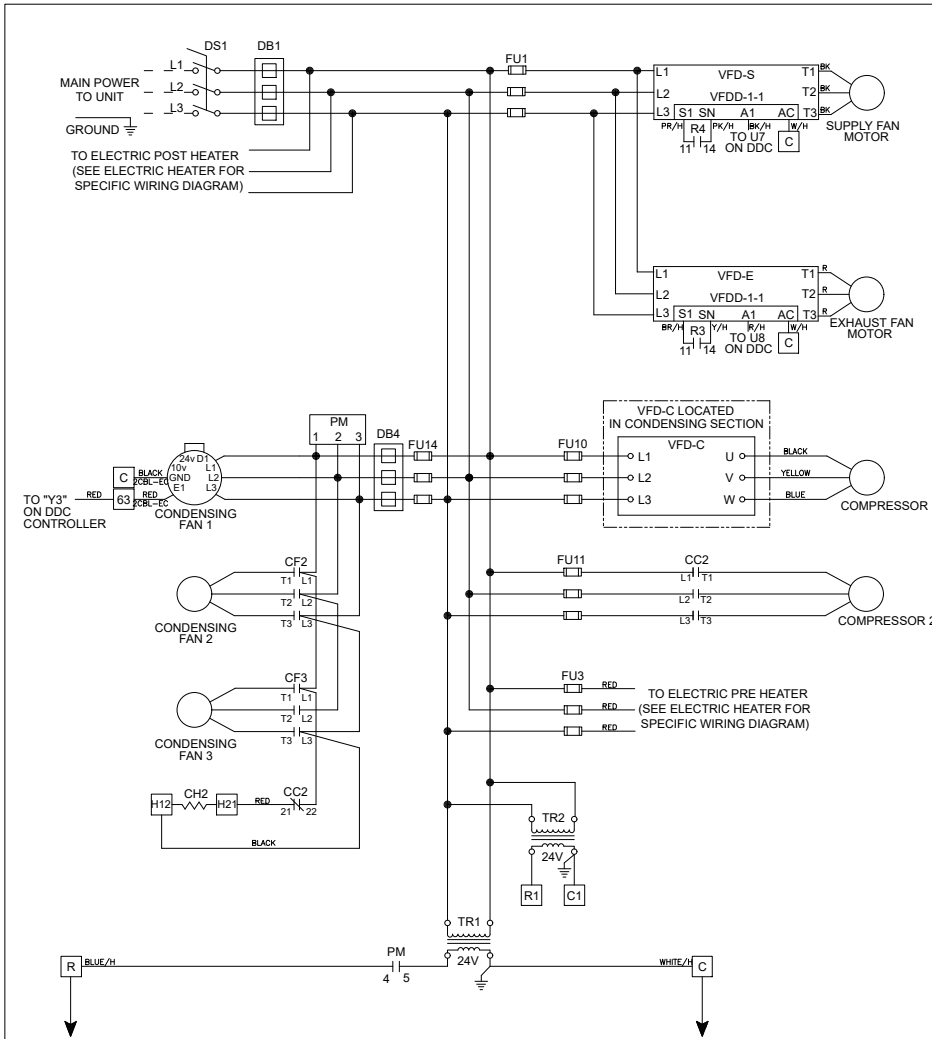

AIR MANAGEMENT SYSTEMS

Wiring Diagram Code:  
**V33Q2A1AB54D04X06NM23F0030BH30**

**CAUTION**

UNIT SHALL BE GROUNDED IN ACCORDANCE WITH N.E.C.  
 POWER MUST BE OFF WHILE SERVICING.

**NOTES**

USE COPPER CONDUCTORS ONLY  
 60° C FOR TERMINALS RATED LESS THAN 100 AMPS.  
 75° C FOR TERMINALS RATED 100 AMPS OR MORE.  
 FIELD CONTROL WIRING RESISTANCE SHOULD NOT EXCEED 0.75 OHM.  
 FIELD WIRED - - - - -  
 FACTORY SUPPLIED AND WIRED \_\_\_\_\_

**WIRE COLOR CODE**

BK	BLACK	BL	BLUE	BR	BROWN
GY	GRAY	LT BL	LIGHT BLUE	O	ORANGE
PK	PINK	PR	PURPLE	R	RED
W	WHITE	Y	YELLOW		

**LEGEND**

CC# COMPRESSOR CONTACTOR  
 CF# CONDENSING FAN CONTACTOR  
 CH# COMPRESSOR SUMP HEATER  
 DB# POWER DISTRIBUTION BLOCK  
 DS DISCONNECT SWITCH  
 FU# FUSES  
 PM PHASE VOLTAGE MONITOR  
 R3 EXHAUST BLOWER VFD RELAY  
 R4 SUPPLY BLOWER VFD RELAY  
 TR# TRANSFORMER  
 VFD VARIABLE FREQUENCY DRIVE

Wiring Template: H30    DOC NUMBER: 3830687    REV: 7



### Wiring Diagram 3

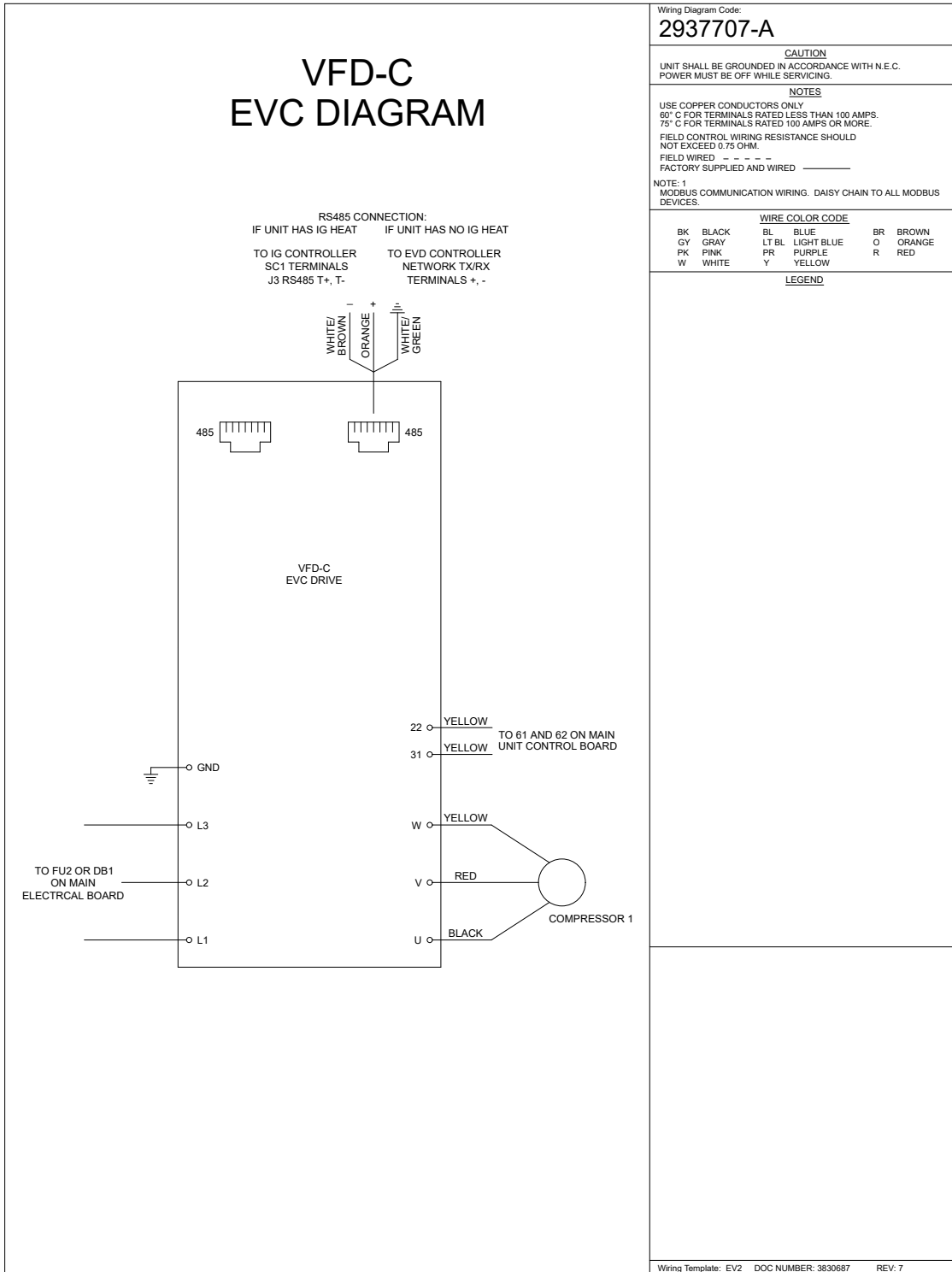

### Monitoring Points Wiring Diagram

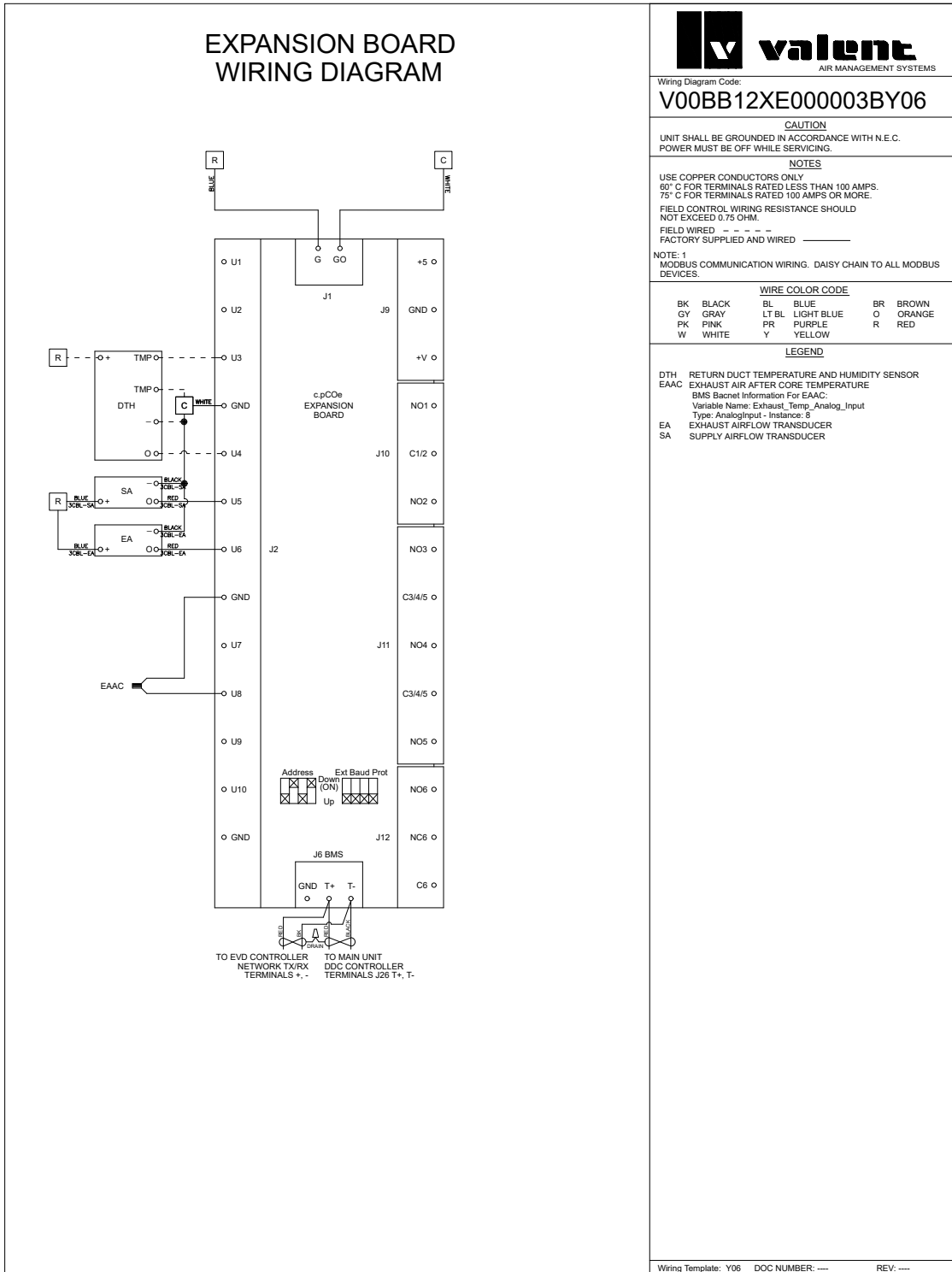

### Valent Network Interface v8 Modbus/BACnet Points List

Variable	Description	BACnet Object	ModBus Object	Read or Write	Text or Unit of M		Included
					Active	Inactive	
Space_Temp_Analog_Input	Space Temperature	AI-1	30002	R		°F	
Supply_Temp_Analog_Input	Supply Temperature	AI-2	30004	R		°F	X
Outside_Air_Temp_Analog_Input	Outside Air Temperature	AI-3	30006	R		°F	X
Mixed_Temp_Analog_Input	Mixed Temperature	AI-4	30008	R		°F	
Cold_Coil_1_Temp_Analog_Input	Cold Coil 1 Temperature	AI-5	30010	R		°F	X
Return_Temp_Analog_Input	Return Temperature	AI-7	30014	R		°F	X
Exhaust_Temp_Analog_Input	Exhaust Temperature	AI-8	30016	R		°F	
Space_RH_Analog_Input	Space % Relative Humidity	AI-9	30018	R		%	
Outside_RH_Analog_Input	Outside % Relative Humidity	AI-10	30020	R		%	
Return_RH_Analog_Input	Return % Relative Humidity	AI-11	30022	R		%	X
Return_Duct_Static_Pressure_Analog_Input	Return Duct Static Pressure	AI-12	30024	R		"wc	
Space_Static_Pressure_Analog_Input	Space Static Pressure	AI-13	30026	R		"wc	
Supply_Duct_Static_Pressure_Analog_Input	Supply Duct Static Pressure	AI-14	30028	R		"wc	
Space_CO2_1_Analog_Input	Space 1 CO2 ppm	AI-15	30030	R		ppm	
Return_CO2_Analog_Input	Return CO2 ppm	AI-17	30034	R		ppm	
Circuit_A_Discharge_Temp_Analog_Input	Circuit A Discharge Temperature	AI-20	30040	R		°F	X
Circuit_A_Suction_Temp_Analog_Input	Circuit A Suction Temperature	AI-21	30042	R		°F	X
Circuit_B_Discharge_Temp_Analog_Input	Circuit B Discharge Temperature	AI-22	30044	R		°F	X
Circuit_B_Suction_Temp_Analog_Input	Circuit B Suction Temperature	AI-23	30046	R		°F	X
Circuit_A_Discharge_Pressure_Analog_Input	Circuit A Discharge Pressure	AI-28	30056	R		psig	X
Circuit_A_Suction_Pressure_Analog_Input	Circuit A Suction Pressure	AI-29	30058	R		psig	X
Circuit_B_Discharge_Pressure_Analog_Input	Circuit B Discharge Pressure	AI-30	30060	R		psig	X
Circuit_B_Suction_Pressure_Analog_Input	Circuit B Suction Pressure	AI-31	30062	R		psig	X
Aux_In_Customer_1	Customer defined auxiliary input	AI-36	30072	R		selectable	
Aux_In_Customer_2	Customer defined auxiliary input	AI-37	30074	R		selectable	
Aux_In_Customer_3	Customer defined auxiliary input	AI-38	30076	R		selectable	
Aux_In_Customer_4	Customer defined auxiliary input	AI-39	30078	R		selectable	
Aux_In_Customer_5	Customer defined auxiliary input	AI-40	30080	R		selectable	
Aux_In_Customer_6	Customer defined auxiliary input	AI-41	30082	R		selectable	
Aux_In_Customer_7	Customer defined auxiliary input	AI-42	30084	R		selectable	
Aux_In_Customer_8	Customer defined auxiliary input	AI-43	30086	R		selectable	
Aux_In_Customer_9	Customer defined auxiliary input	AI-44	30088	R		selectable	
Aux_In_Customer_10	Customer defined auxiliary input	AI-45	30090	R		selectable	
Temperature_Setpoint	Main Temperature Set point Supply, Space, or Return target temperature	AV-1	40002	RW		°F	X
Temperature_Heat_Cool_Deadband	Heat/Cool Spt Deadband when Room or Return control is active Clg Spt = Deadband /2 + Temp Spt Htg Spt = Deadband /2 - Temp Spt	AV-2	40004	RW		Delta in °F	X
Temperature_Setpoint_Unoccupied	Main Temperature Set point Supply, Space, or Return target temperature	AV-3	40006	RW		°F	
Temperature_Heat_Cool_Deadband_Unoccupied	Heat/Cool Spt Deadband when Room or Return control is active Clg Spt = Deadband /2 + Temp Spt Htg Spt = Deadband /2 - Temp Spt	AV-4	40008	RW		Delta in °F	
Cooling_Coil_Setpoint_Min	Cooling Coil Leaving Air Setpoint	AV-5	40010	RW		°F	X
Cooling_Coil_Setpoint_Max	Maximum Coil Leaving Setpoint	AV-6	40012	RW		°F	X
Dehumidification_Setpoint	Dehumidification Setpoint %RH for Space or Return control	AV-7	40014	RW		%	
Outside_Dewpoint_Setpoint	Outside Dewpoint Dehumidification Trigger	AV-8	40016	RW		°F	
Indoor_Dewpoint_Setpoint	Indoor Dewpoint Dehumidification Trigger	AV-9	40018	RW		°F	
Unocc_Indoor_Dewpoint_Setpoint	Unoccupied Indoor Dewpoint Dehumidification Trigger	AV-10	40020	RW		°F	
Unoccupied_Dehumidification_Setpoint	Unoccupied Dehumidification %RH Setpoint	AV-11	40022	RW		°F	
Economizer_Temp_Enable_Setpoint	Economizer Ambient Temp Enable Setpoint Allow Econ when OAT is less than Setpoint	AV-12	40024	RW		°F	
Economizer_Enthalpy_Enable_Setpoint	Economizer Enthalpy Enable Setpoint Allow Econ when OA Enthalpy is less than Setpoint	AV-13	40026	RW		btu/lb	
Cooling_Lockout_Setpoint	Cooling Ambient Lockout Setpoint	AV-17	40034	RW		°F	X
Heating_Lockout_Setpoint	Heating Ambient Lockout Setpoint	AV-18	40036	RW		°F	X
Preheat_Lockout_Setpoint	Preheat Ambient Lockout Setpoint	AV-19	40038	RW		°F	X
Economizer_Lockout_Setpoint	Economizer Ambient Lockout Setpoint	AV-20	40040	RW		°F	
Return_Duct_Static_Pressure_Setpoint	Return Duct Static Pressure Setpoint	AV-21	40042	R		"wc	
Space_Static_Pressure_Setpoint	Space Static Pressure Setpoint	AV-22	40044	RW		"wc	
Supply_Duct_Static_Pressure_Setpoint	Supply Duct Static Pressure Setpoint	AV-23	40046	RW		"wc	
Space_CO2_Setpoint	Space CO2 Setpoint	AV-24	40048	RW		ppm	
Outside_Air_Damper_Minimum_Setpoint_Occ	Outside Air Damper Minimum Setpoint	AV-24	40050	RW		%	
Outside_RH_from_BMS	Outside RH from BMS Used when source selection is set to BMS	AV-26	40052	RW		%	X
Outside_Temp_from_BMS	Outside Temp from BMS Used when source selection is set to BMS	AV-27	40054	RW		°F	X
Return_RH_from_BMS	Return RH from BMS Used when source selection is set to BMS	AV-28	40056	RW		%	X
Return_Temp_from_BMS	Return Temp from BMS Used when source selection is set to BMS	AV-29	40058	RW		°F	X

**Valent Network Interface v8 Modbus/BACnet Points List**

Variable	Description	BACnet Object	ModBus Object	Read or Write	Text or Unit of M		Included
					Active	Inactive	
Space_1_CO2_from_BMS	Space 1 CO2 from BMS Used when source selection is set to BMS	AV-30	40060	RW		ppm	X
Return_CO2_from_BMS	Return CO2 from BMS Used when source selection is set to BMS	AV-32	40062	RW		ppm	X
Space_RH_from_BMS	Space RH from BMS Used when source selection is set to BMS	AV-33	40066	RW		%	X
Space_Static_from_BMS	Space Static from BMS Used when source selection is set to BMS	AV-34	40068	RW		"wc	X
Space_Temp_from_BMS	Space Temp from BMS Used when source selection is set to BMS	AV-35	40070	RW		°F	X
SF_Control_Signal_BMS	BMS to control signal for supply fan speed	AV-36	40072	RW		%	X
EF_Control_Signal_BMS	BMS to control signal for exhaust fan speed	AV-37	40074	RW		%	X
OAD_Control_Signal_BMS	Allows the BMS to control OAD position	AV-38	40076	RW		%	
Aux_BMS_Analog_Output_1	BMS Commanded auxiliary analog output	AV-39	40078	RW		selectable	X
Unit_Status_Mode	Unit Status Mode - See Table	AV-40	30092	R		Real	X
Supply_Temperature_Calculated_Setpoint	Active Supply Temperature Setpoint	AV-41	30094	R		°F	X
Cooling_1_Ramp_Capacity	Cooling Ramp 1 Status Value	AV-42	30096	R		%	X
Defrost_Ramp	Defrost Ramp	AV-44	30100	R		%	X
Economizer_Ramp	Economizer Ramp	AV-45	30102	R		%	
Head_Pressure_Control_Ramp_1_Ramp	Head Pressure Control Ramp 1	AV-46	30104	R		%	X
Head_Pressure_Control_Ramp_2_Ramp	Head Pressure Control Ramp 2	AV-47	30106	R		%	
HP_Ramp_Capacity	Heat Pump Heating Ramp	AV-50	30112	R		%	X
Heating_Capacity	Heating Ramp	AV-51	30114	R		%	X
Case_Heat_Control_Ramp	Case Heat Ramp	AV-52	30116	R		%	
Hot_Gas_Reheat_Ramp	Hot Gas Reheat Ramp	AV-53	30118	R		%	X
Outside_Dewpoint	Outside Dewpoint	AV-54	30120	R		°F	
Outside_Enthalpy	Outside Enthalpy	AV-55	30122	R		btu/lb	
Return_Dewpoint	Return Dewpoint	AV-56	30124	R		°F	X
Return_Enthalpy	Return Enthalpy	AV-57	30126	R		btu/lb	X
Space_Dewpoint	Space Dewpoint	AV-58	30128	R		°F	
Space_Enthalpy	Space Enthalpy	AV-59	30130	R		btu/lb	
Circuit_A_Superheat	Circuit A Superheat	AV-60	30132	R		°F	X
Circuit_B_Superheat	Circuit B Superheat	AV-61	30134	R		°F	X
Total_Exhaust_Fan_CFM_BMS	Total Exhaust Fan CFM	AV-64	30140	R		CFM	X
Total_Supply_Fan_CFM_BMS	Total Supply Fan CFM	AV-65	30142	R		CFM	X
OAD_CFM_BMS	OAD CFM	AV-66	30144	R		CFM	X
Active_Temperature_Setpoint	Active Temperature Setpoint	AV-67	30146	R		°F	X
Chilled_Water_1_Valve_Analog_Output	Chilled Water 1 Valve Analog Output	AV-68	30148	R		%	
Electric_Heater_1_Analog_Output	Electric Heater 1 Analog Output	AV-70	30152	R		%	
Energy_Recovery_Analog_Output	Energy Recovery Analog Output	AV-72	30156	R		%	
Exhaust_Fan_Speed_Analog_Output	Exhaust Fan Speed Analog Output	AV-73	30158	R		%	X
Hot_Water_Valve_1_Analog_Output	Hot Water Valve 1 Analog Output	AV-74	30160	R		%	
Mod_Gas_Furnace_1_Analog_Output	Mod Gas Furnace 1 Analog Output	AV-76	30164	R		%	
Outside_Air_Damper_Analog_Output	Outside Air Damper Analog Output	AV-78	30168	R		%	
Supply_Fan_Speed_Analog_Output	Supply Fan Speed Analog Output	AV-79	30170	R		%	X
Modulating_Compressor_Analog_Output_BMS	First Modulating Compressor Analog Output - BMS	AV-80	30172	R		%	X
Circuit_A_Sat_Discharge_Temperature	Circuit A Saturated Discharge Temperature	AV-82	30176	R		°F	X
Circuit_B_Sat_Discharge_Temperature	Circuit B Saturated Discharge Temperature	AV-83	30178	R		°F	X
Circuit_A_Sat_Suction_Temperature	Circuit A Saturated Suction Temperature	AV-86	30184	R		°F	X
Circuit_B_Sat_Suction_Temperature	Circuit B Saturated Suction Temperature	AV-87	30186	R		°F	X
Coil_Temperature_Calculated_Setpoint	Calculated Coil Leaving Set point	AV-90	30192	R		°F	X
Unoccupied_Cooling_Setpoint	Active Cooling Setpoint - Unoccupied	AV-91	30194	R		°F	
Unoccupied_Heating_Setpoint	Active Heating Setpoint - Unoccupied	AV-92	30196	R		°F	
Temperature_Reset_Mode	Occupied Reset Type Setpoint 1-No Reset(Supply Temp Control) 2-Space 3-Return 4-Outside	IV-1	40080	RW		Integer	X
Temperature_Reset_Mode_Unoccupied	Unoccupied Reset Type Setpoint 1-No Reset(Supply Temp Control) 2-Space 3-Return 4-Outside	IV-2	40082	RW		Integer	
Active_Temperature_Reset_Mode	Active Occupied Reset Type Setpoint 1-No Reset(Supply Temp Control) 2-Space 3-Return 4-Outside	IV-3	30198	R		Integer	X
Active_Temperature_Reset_Mode_Unocc	Active Unoccupied Reset Type Setpoint 1-No Reset(Supply Temp Control) 2-Space 3-Return 4-Outside	IV-4	30200	R		Integer	
LatestAlm	Most recent alarm - See Alarm Table	IV-5	30202	R		Integer	X
Device_Enable_DO_Word	Device Enable DO Word - See Table	IV-6	30206	R		Bit Pack	X
Ref_Ckt_PressTemp_Alarm_Word	Refrigeration Circuit Word - See Table	IV-7	30210	R		Bit Pack	X
Device_Offline_Word	Device Offline Word - See Table	IV-8	30214	R		Bit Pack	X
Device_Alarm_Word	Device Alarm Word - See Table	IV-9	30218	R		Bit Pack	X
System_Word	System Word - See Table	IV-10	30222	R		Bit Pack	X
Unit_Status_Word	Unit Status Word - See Table	IV-11	30226	R		Bit Pack	X
Exhaust_Fan_1_Status_Digital_Inpu	Exhaust Fan Status	BI-1	10009	R		Active Inactive	X
Supply_Fan_1_Status_Digital_Input	Supply Fan Status	B-2	10010	R		Active Inactive	X

**Valent Network Interface v8 Modbus/BACnet Points List**

Variable	Description	BACnet Object	ModBus Object	Read or Write	Text or Unit of M		Included
					Active	Inactive	
Exhaust_Fan_1_Status_Digital_Input	Exhaust Fan Status	BI-1	10009	R	Active	Inactive	X
Supply_Fan_1_Status_Digital_Input	Supply Fan Status	B-2	10010	R	Active	Inactive	X
BMS_Watchdog	BMS Watchdog command Used to determine BMS comm status Must heartbeat within the watch dog timeout delay to detect comm status	BV-1	2	RW	Active	Inactive	X
System_Enable	Master system enable/disable point	BV-2	3	RW	Enable	Disable	X
BMS_Occupancy_Command	Occupancy Command	BV-3	4	RW	Unoccupied	Occupied	X
Reset_All_Alarms	Alarm Reset Command	BV-4	5	RW	Reset	Normal	X
Exhaust_Only_Mode_BMS_Cmd	Emergency Exhaust Mode Command	BV-5	6	RW	Enable	Disable	
Pressurization_Only_Mode_BMS_Cmd	Emergency Pressurization Mode Command	BV-6	7	RW	Enable	Disable	
Outside_RH_Source_BMS	Outside RH Source Selection	BV-7	8	RW	BMS	Local	X
Outside_Temp_Source_BMS	Outside Temp Source Selection	BV-8	9	RW	BMS	Local	X
Return_RH_Source_BMS	Return RH Source Selection	BV-9	10	RW	BMS	Local	X
Return_Temp_Source_BMS	Return Temp Source Selection	BV-10	11	RW	BMS	Local	X
Space_1_CO2_Source_BMS	Space 1 CO2 Source Selection	BV-11	12	RW	BMS	Local	X
Space_2_CO2_Source_BMS	Space 2 CO2 Source Selection	BV-12	13	RW	BMS	Local	X
Return_CO2_Source_BMS	Return CO2 Source Selection	BV-13	14	RW	BMS	Local	X
Space_RH_Source_BMS	Space RH Source Selection	BV-14	15	RW	BMS	Local	X
Space_Static_Source_BMS	Space Static Source Selection	BV-15	16	RW	BMS	Local	
Space_Temp_Source_BMS	Space Temp Source Selection	BV-16	17	RW	BMS	Local	X
SF_Control_Source_BMS	Allows the BMS to control supply fan speed	BV-17	18	RW	BMS	Local	X
EF_Control_Source_BMS	Allows the BMS to control exhaust fan speed	BV-18	19	RW	BMS	Local	X
OAD_Control_Source_BMS	Allows the BMS to control OAD position	BV-19	20	RW	BMS	Local	
Aux_BMS_Digital_Output_1	BMS Commanded auxiliary digital output	BV-20	21	RW	Active	Inactive	
Aux_BMS_Digital_Output_2	BMS Commanded auxiliary digital output	BV-21	22	RW	Active	Inactive	
Occupied	Occupancy	BV-22	10002	R	Occupied	Unoccupied	X
Global_Alarm	General alarm point Optionally set to indicate any alarm is active, or a shutdown alarm is active	BV-23	10003	R	Alarm	Normal	X
BMS_Watchdog_Active	Status of the BMS watchdog heartbeat	BV-24	10004	R	Active	Inactive	X
OAD_Feedback_Error_Not_Economizing.Active	Feedback indicates OAD is not opening during economizer	BV-25	10005	R	Alarm	Normal	
OAD_Feedback_Error_Economizing.Active	Feedback indicates OAD is open	BV-26	10006	R	Alarm	Normal	
OAD_Feedback_Error_OAD_Not_Modulating.Active	Feedback indicates the OAD is not modulating	BV-27	10007	R	Alarm	Normal	
OAD_Feedback_Error_Excess_OA.Active	Feedback indicates the OAD is not closing	BV-28	10008	R	Alarm	Normal	



System Word Table (IV-10)	
Bit	System_Word
0	Heat Wheel Enable
1	Preheat Enable
2	Reversing Valve (Cooling (0)/Heating(1))
3	
4	
5	
6	Supply Temp Low Limit Alarm
7	Supply Temp High Limit Alarm
8	Supply High Duct Static Alarm.Active
9	Supply Fan 1 Alarm
10	Exhaust Fan 1 Alarm
11	Drain Pan Alarm
12	Freeze Stat Alarm
13	Filter Alarm
14	Space High Static Alarm
15	Return Low Static Alarm
16	Shutdown Input Alarm
17	Energy Recovery Wheel High Diff Pressure
18	Energy Recovery Wheel Rotation Alarm
19	
20	Heat Pump Heating Lock Out Alarm
21	Permanent Memory - Too Many Writes
22	BMS Offline Alarm
23	
24	
25	
26	
27	
28	Heat-Cool Only - Dehumidification Request Active
29	Heat-Cool Only - Heating Request Active
30	Heat-Cool Only - Coil Setpoint Alarm Active
31	Heat-Cool Only - Supply Setpoint Alarm Active

Unit Status Word Table (IV-11)	
Bit	Unit_Status_Word
0	Off/Standby
1	Unoccupied Start
2	Occupied Start
3	Opening Dampers
4	Dampers Open
5	Fan Start Delay
6	Exhaust Fan On
7	Supply Fan On
8	System On
9	Soft Shutdown
10	System Disabled
11	Remote Off
12	System Shutdown Alarm
13	Supply Fan Only
14	Exhaust Fan Only
15	Purge Mode (Supply and Exhaust Only)
16	Case Heat Active
17	Fans Only
18	Economizing
19	Energy Recovery Active
20	Cooling
21	Heating
22	Dehumidifying
23	Hot Gas Reheat Active
24	HGRH Purging
25	Dehum w/Heat
26	Energy Recovery Defrost Active
27	Heat Pump Defrost Active
28	Morning Warm Up/Cool Down Active
29	Winter Ramp Active
30	
31	Overrides Active

Device Enable DO Word Table (IV-6)	
Bit	Device_Enable_DO_Word
0	Compressor 1 Start
1	Compressor 2 Start
2	Compressor 3 Start
3	Compressor 4 Start
4	
5	
6	
7	
8	Condenser Fan Ramp 1 Stage 1 Start
9	Condenser Fan Ramp 1 Stage 2 Start
10	Condenser Fan Ramp 1 Stage 3 Start
11	
12	Condenser Fan Ramp 2 Stage 1 Start
13	Condenser Fan Ramp 2 Stage 2 Start
14	Condenser Fan Ramp 2 Stage 3 Start
15	
16	Furnace 1 Start (External Furnace Controller Only)
17	Furnace 2 Start (External Furnace Controller Only)
18	
19	
20	Supply Fan Start
21	Exhaust Fan Start
22	
23	
24	
25	
26	
27	
28	
29	
30	
31	

Unit Status Word Table (IV-11)	
Bit	Ref_Ckt_PressTemp_Alarm_Word
0	Circuit A Discharge Pressure Sensor Alarm
1	Circuit A Discharge Temp Sensor Alarm
2	Circuit A Suction Pressure Sensor Alarm
3	Circuit A Suction Temp Sensor Alarm
4	Circuit B Discharge Pressure Sensor Alarm
5	Circuit B Discharge Temp Sensor Alarm
6	Circuit B Suction Pressure Sensor Alarm
7	Circuit B Suction Temp Sensor Alarm
8	Circuit A High Pressure Switch Alarm
9	Circuit A Low Pressure Switch Alarm
10	Circuit B High Pressure Switch Alarm
11	Circuit B Low Pressure Switch Alarm
12	Circuit A High Sat Discharge Temp Alarm
13	Circuit B High Sat Discharge Temp Alarm
14	
15	
16	
17	
18	
19	
20	
21	
22	
23	
24	
25	
26	
27	
28	
29	
30	
31	

Device Alarm Word Table (IV-9)	
Bit	Device_Alarm_Word -Ext
0	Cold Coil Temperature Sensor Alarm
1	
2	Mixed Temperature Sensor Alarm
3	Supply Duct Static Pressure Sensor Alarm
4	Supply Fan AFMS Alarm
5	Supply Air Temp Sensor Alarm
6	Exhaust Fan AFMS Alarm
7	Exhaust Temperature Sensor Alarm
8	Outside Air Temp Sensor Alarm
9	Outside RH Sensor Alarm
10	OAD AMD Alarm
11	Greentrol OAD AFMS Alarm
12	Return CO2 Sensor Alarm
13	Return Duct Static Pressure Sensor Alarm
14	Return Temperature Sensor Alarm
15	Return RH Sensor Alarm
16	Space CO2 Sensor Alarm
17	Space RH Sensor Alarm
18	Space Static Pressure Sensor Alarm
19	Space Temperature Sensor Alarm
20	IG Furnace Alarm
21	
22	Inverter Scroll 1 Alarm
23	
24	EVD Valve A Alarm
25	
26	SF VFD Alarm
27	
28	
29	
30	
31	

Device Offline Word Table (IV-8)	
Bit	Device_Offline_Word - Ext
0	Space TStat 1 Offline
1	Space TStat 2 Offline
2	Space TStat 3 Offline
3	Space TStat 4 Offline
4	VFD Offline Supply Fan
5	
6	
7	
8	Expansion Board 1 Alarm
9	Expansion Board 2 Alarm
10	Expansion Board 3 Alarm
11	Expansion Board 4 Alarm
12	
13	
14	
15	
16	
17	
18	
19	
20	
21	
22	
23	
24	
25	
26	
27	Master Unit Offline Alarm
28	Slave Unit 1 Offline Alarm
29	Slave Unit 2 Offline Alarm
30	Slave Unit 3 Offline Alarm
31	Slave Unit 4 Offline Alarm

UNIT STATUS MODE TABLE (AV-40)			
0	Off/Standby	17	Fans Only Purge
1	Unoccupied Start	18	Case Heat Active
2	Occupied Start	19	Fans Only
3	Opening Dampers	20	Economizing
5	Dampers Open	21	Cooling
6	Fan Start Delay	22	Heating
7	Exhaust Fan Start	23	Dehumidifying
8	Supply Fan Start	25	HGRH Purging
9	Startup Delay	26	Energy Recovery Defrost Active
10	System On	29	Dehumidifying w/Heat
11	Soft Shutdown	30	Overrides
12	System Disabled	31	Expansion Offline
13	Remote Off	33	Energy Recovery Active
14	System Shutdown Alarm	34	Hot Gas Reheat Active
15	Pressurization Only	35	Morning Warm Up/Cool Down Active (Sequence)
16	Exhaust Only	36	Heat Pump Defrost



Alarm Table (Latest Alarm IV-5)					
0	No Active Alarms	63	Supply Air Temperature - Low Limit Shutdown	117	High SDT Lockout - Circuit A
1	Supply Fan 1 Run - Status Not Proven	64	Heat Wheel Rotation - Not Detected	118	High SDT Lockout - Circuit B
2	Freeze Protection - Thermostat Tripped	65	Slave Unit 1 Offline -	121	Inverter 1 Alarm -
3	High Supply Duct - Static Pressure	66	Slave Unit 2 Offline -	123	Inverter 1 Lockout - Cycle Power to Unit
4	Low Return Duct - Static Pressure	67	Slave Unit 3 Offline -	125	High SDT Lockout - Circuit A
5	Outside Air Temp - Sensor Value Not Valid	68	Slave Unit 4 Offline -	126	Inverter 1 Foldback - Input Current
6	Supply Air Temperature - Sensor Value Not Valid	69	Master Unit Offline -	127	Inverter 1 Foldback - Inverter Temp
7	Cold Coil 1 Temp - Sensor Value Not Valid	70	Heat Pump Defrost - Mode is Active	131	Inverter 1 Comms Lost - Compressor Offline
9	Exhaust Air Temp - Sensor Value Not Valid	71	Multi Devices per Ch - Contact Tech Support	133	Space Thermostat 1 - Sensor Offline
10	Mixed Air Temperature - Sensor Value Not Valid	74	Shutdown Contact - In Alarm Position	134	Space Thermostat 2 - Sensor Offline
11	Return Air Temperature - Sensor Value Not Valid	75	Comp Maint Alarm - Run Hours Spt Reached	135	Space Thermostat 3 - Sensor Offline
12	Space Temperature - Sensor Value Not Valid	76	Supply Air Temperature - High Limit Shutdown	136	Space Thermostat 4 - Sensor Offline
13	Return Air RH - Sensor Value Not Valid	77	Space High Static Pres - Shutdown	137	IG Furnace 1. No flame - after 3 tries
14	Space RH - Sensor Value Not Valid	78	Internal Board Temp - Exceeds -40F or 158F	138	IG Furnace 1 Large - no flame after 3 tries
15	Outside RH - Sensor Value Not Valid	79	BMS Offline - Watchdog is FALSE	139	IG Furnace 1 combust - fan high pressure sw
16	Low Pressure Switch - Circuit A	80	Clg Coil Setpt Input - Value is not valid	140	IG Furnace 1 Ignition - controller alarm
17	Low Pressure Switch - Circuit B	81	Sup Air Setpt Input - Value is not valid	141	IG Furnace 1 pressure - switch fault alarm
20	High Pressure Switch - Circuit A	82	BACnet License - Not Installed	142	High SDT Lockout - Circuit B
21	High Pressure Switch - Circuit B	83	Low Suction SH ExV A - EVD 1 Alarm	143	IG Furnace 1 - Max retrys
24	Damper End Switch Fail - Dampers are not open	84	Low Suction SH ExV B - EVD 1 Alarm	144	IG Furnace 1 - High Limit Trip
25	Exhaust Fan 1 Run - Status Not Proven	85	LOP A EVD 1 - Low Operating Pressure	145	IG Furnace - pCOe 1 Offline
26	Filters are Dirty - Replace Filters	87	MOP A EVD 1 - Max Operating Pressure	146	IG Furnace 1 IC fault - Check Furnace Wiring
27	Cond Drain Pan Full - Check Drain	89	EEV A EVD 1 - Motor Alarm	147	IG Furnace 2 No flame - after 3 tries
28	Exp Board 1 Status - Board is Offline	91	LowSuct A EVD 1 - Refrigerant Temp	148	IG Furnace 2 Large - no flame after 3 tries
29	Exp Board 2 Status - Board is Offline	93	High Condensing Temp - EVD 1	149	IG Furnace 2 combust - fan high pressure sw
31	Exp Board 4 Status - Board is Offline	94	Sens S1 EVD 1 - Sensor Value Not Valid	150	IG Furnace 2 Ignition - controller alarm
32	Non-Volatile Memory Er - Contact Tech Support	95	Sens S2 EVD 1 - Sensor Value Not Valid	151	IG Furnace 2 pressure - switch fault alarm
33	Space 1 CO2 - Sensor Value Not Valid	96	Sens S3 EVD 1 - Sensor Value Not Valid	152	IG Furnace 2 combust - fan proving alarm
34	Space Static Pressure - Sensor Value Not Valid	97	Sens S4 EVD 1 - Sensor Value Not Valid	153	IG Furnace 2 - Max retrys
35	Supply Duct Stat Press - Sensor Value Not Valid	98	EVD 1 EEPROM Damaged - Call Tech Support	154	IG Furnace 2 - High Limit Trip
36	Return Duct Stat Press - Sensor Value Not Valid	99	Incomplete Closing - EVD 1	155	IG Furnace - pCOe 2 Offline
37	Sup Fan AFMS - Sensor Value Not Valid	101	Emergency Closing - EVD 1	156	IG Furnace 2 IC fault - Check Furnace Wiring
38	Exh Fan AFMS - Sensor Value Not Valid	101	EVD 1 Battery -	157	Outside Air Greentrol - Offline or Flow Error
39	Outside Damper AFMS - Sensor Value Not Valid	102	FW Incompatibility - EVD 1	158	Exhaust Air Greentrol - Offline or Flow Error
40	Space Setpt Adj Slider - Sensor Value Not Valid	106	EVD 1 Config Error -	159	Supply Air Greentrol - Offline or Flow Error
42	Return CO2 - Sensor Value Not Valid	105	High Discharge Temp - First Inverter	170	OA Damper Fault - Not Econ and should be
42	Discharge Press Ckt A - Sensor Value Not Valid	106	Low Discharge Pressure - First Inverter	171	OA Damper Fault - Econ and shouldn't be
43	Discharge Press Ckt A - Sensor Value Not Valid	106	Low Discharge Pressure - First Inverter	171	OA Damper Fault - Econ and shouldn't be
44	Discharge Press Ckt B - Sensor Value Not Valid	107	High Suction Pressure - First Inverter	172	OAD Fault - Damper not Modulating
47	Suction Press Ckt A - Sensor Value Not Valid	108	Low Suction Pressure - First Inverter	173	OAD Fault - Excess Outdoor Air
48	Suction Press Ckt B - Sensor Value Not Valid	109	High Current - First Inverter	174	IG Furnace 1 - Combustion Fan Alarm
51	Discharge Temp Ckt A - Sensor Value Not Valid	110	High Pressure Ratio - First Inverte	175	IG Furnace 2 - Combustion Fan Alarm
52	Discharge Temp Ckt B - Sensor Value Not Valid	111	Low Pressure Ratio - First Inverter	176	Supply Fan - VFD Offline
55	Suction Temp Ckt A - Sensor Value Not Valid	112	Low Delta P - First Inverter	177	OA Damper Fault - Not Econ and should be
56	Suction Temp Ckt B - Sensor Value Not Valid	113	High Discharge Press - First Inverter	178	Return Fan - VFD Offline
59	Ckt A High Saturated - Discharge Temperature	114	Compressor Staging - Order Skipped	179	Energy Recovery - VFD Offline
60	Ckt B High Saturated - Discharge Temperature	115	Heat Pump Heating - Locked Out	180	Embedded EVD Error
.		116	EVD 1 Error - Unexpected Position	181	SF VFD Alarm - Check VFD

## Factory Controller Sequence of Operation

**FACTORY CONTROLLER:** Controller shall be provided with required sensors and programming for rooftop unit. Controller shall be factory programmed, mounted and tested. Controller shall have a LCD readout for changing set points and monitoring unit operation.

**UNIT START COMMAND (Unit will be enabled to start once a jumper is placed between R to G):**

- Factory mounted and wired outdoor air damper actuator is powered
- Exhaust fan starts after a (adj.) delay.
- Supply fan starts after a (adj.) delay.
- Tempering options and energy core option to function as described below.

**UNIT STOP COMMAND (OR DE-ENERGIZED):**

- Supply fan, exhaust fan and tempering options de-energized.
- Outdoor air damper actuator is spring return close.

**OCCUPIED/UNOCCUPIED MODES:** Shall be based on a 7-day time clock internal to the controller. The schedule shall be set by the end user. When a user initiates an override input, the controller will switch from unoccupied to occupied mode. The controller will return to the scheduled occupied/unoccupied mode after the override time has expired. If internal time clock is disabled, a remote contact or a BMS can control the occupied/unoccupied mode.

**Occupied Mode:**

- Damper control per below.
- Exhaust fan ON.
- Supply fan ON.
- Heating per below.
- Cooling per below.

**Unoccupied Mode (Unit Off):** Unit remains off when in unoccupied mode.

- Supply fan OFF
- Exhaust fan OFF
- Tempering OFF
- Outdoor air damper closed.

**MORNING WARMUP/COOL DOWN:** Prior to occupancy, the unit will run using the warmup or cool down sequence until the occupied set point is achieved. The heating or cooling mode must not be locked out and the space temperature is below or above set point by the unoccupied hysteresis (adj.) (This Sequence must be field configured.)

**SUPPLY BLOWER SEQUENCE:** The supply blower is provided with a factory mounted variable frequency drive. The supply blower speed will be controlled with the following sequence. Minimum supply fan turndown is 50% of the design maximum operation.

**Constant Volume-Adj. Setpoint:** The supply blower will operate at a constant speed set point (adj.) during operation.

**Constant Volume-Adj. Setpoint:** The exhaust blower will operate at a constant speed set point (adj.) during operation.

**COOLING SEQUENCE:** The cooling is controlled to maintain the supply temperature set point. The mechanical cooling will be locked out when the outside air is < 55 F (adj.).

**Air-Source Heat Pump:** The controller will provide a modulating signal for cooling. From 0-50%, the inverter scroll will be controlled to maintain discharge temperature. From 50-100% the second stage will be on in combination with the inverter scroll compressor to maintain the discharge temperature. The electronic expansion valve will modulate to maintain 10 F of superheat.

**Modulating Hot Gas Reheat Sequence:** During dehumidification the modulating HGRH is controlled to maintain the supply temperature set point.

**Modulating Hot Gas Reheat:** The controller will modulate the hot gas reheat reheat valve with a 0-10 V signal to maintain the supply temperature set point (adj.).

**PRIMARY HEATING SEQUENCE:** The air-source heat pump is controlled to maintain the supply temperature set point. Heating will be locked out when the outside air is > 80 F (adj.). The air-source heat pump will be locked out when outside temperatures are < 10 F.

**Air-Source Heat Pump:** The controller will provide a modulating signal for heating. From 0-50%, the inverter scroll will be controlled to maintain discharge temperature. From 50-100% the second stage will be on in combination with the inverter scroll compressor to maintain the discharge temperature. The electronic expansion valve will modulate to maintain 10 F of superheat.

**SECONDARY HEATING SEQUENCE:** If the air-source heat pump cannot meet the supply temperature set point, the secondary heating source will activate and work in conjunction with the air-source heat pump.

**Electric Heater:** The controller will modulate an electric heater to maintain the supply temperature set point (adj.).

**TEMPERATURE CONTROL SEQUENCE:** The unit will maintain the supply air discharge setpoint per the following. Adjustable locally or by BMS.

**Room Reset:** The controller will reset the supply air temperature set point to maintain the room temperature set point (adj.).

**Supply Discharge Temperature Control:** The supply setpoint will be a constant temperature setpoint from the controller (adj.). Adjustable locally or by BMS.

**BUILDING FREEZE PROTECTION:** If the supply air temperature drops below 35 F (adj.) for 300s (adj.), the controller will de-energize the unit and activate the alarm output.

**TEMPERATURE PROTECTION:** The controller will enable the supply fan to modulate down to help the unit keep up with heating demand in the event of wheel failure or the unit operating outside design conditions. (This can be enabled under the manufacturer menu in the controller)

**ENERGY CORE FROST CONTROL:** Frost control for the energy core enables when the exhaust air temperature falls below 30 degrees (F).

**Preheat:** When the outdoor air temperature drops below the preheat setpoint, 10 deg (F), the preheater is energized. Once the outdoor air temperature increases above the temperature set point the unit will resume normal operation.

**ALARMS INDICATION:** The controller will display alarms and have one digital output for remote indication of an alarm condition. Possible alarms include:

**Building Management System:** The controller will send all alarms to the BMS.

**Dirty Filter Alarm:** A digital signal is sent to the controller indicating an increased pressure drop across the outdoor, exhaust, or supply air filters (Must be adjusted in field during start up). The controller will then provide a dirty filter alarm.

**Supply and Exhaust Air Alarm:** The controller monitors the proving switch on each blower and sends an alarm in the case of either blower proving switch not engaging.

**Temperature Sensor Alarm:** The controller sends an alarm in the case of a failed air temperature sensor.

**ACCESSORIES:** The following accessories will be included with the unit to expand the functionality or usability of the controller.

**BMS Interfacing:** A BMS port or serial card is provided with the controller for field interfacing with a building management system. Each card is sent out with the default parameters, and the controls contractor must change the appropriate addresses to match the BMS settings.

**Phase and Brownout Protection:** Factory mounted and wired component which monitors the main power coming into the unit. If a phase drops out, or if the incoming voltage exceeds the acceptable range, the component will turn off the unit to help protect the electrical systems.

**Airflow Monitoring:** The supply and exhaust fans will each have an airflow monitoring pressure tap on the inlet cone. The differential pressure across the fan cone is converted to an airflow reading by using the energy conservation principle and the fan wheel K-factor. The airflow can be monitored via the LCD and BAS.

**Damper End Switch:** Damper end switched will be provided to ensure the supply and exhaust fans do not enable until the dampers are proven open.



## Warranty Statement for Dedicated Outdoor Air Systems (DOAS)

### Unit Warranty

Valent warrants the equipment to be free from defects in material and workmanship for a period of 18 months from ship date. Initial startup must be completed within six months of the shipment date, and a startup report must be submitted to Valent.

### Total Energy Core Warranty

The enthalpy core is warranted to be free from defects in material and workmanship for a period of 5 years from the shipment date.

### Compressor Extended Warranty

Valent warrants the refrigerant compressor(s) to be free from defects in material and workmanship for a period of 5.5 years from the shipment date.

### Warranty Notes

Any component which proves defective during the warranty period will be repaired or replaced at Valent's sole option when returned to our factory, transportation prepaid. All warranties do not include labor costs associated with troubleshooting, removal, or installation. Valent will not be liable for any consequential, punitive, or incidental damages resulting from use, repair, or operation of any Valent product. These warranties are exclusive and are in lieu of all other warranties, whether written, oral, or implied, including the warranty of merchantability and the warranty of fitness for a particular purpose. No person (including any agent or salesperson) has authority to expand Seller's obligation beyond the terms of this warranty, or to state that the performance of the product is other than that published by Seller.

*As a result of our commitment to continuous improvement, Valent reserves the right to change specifications without notice.*

## GKD Roof Curb

Model: GKD-61.6/190.6-G14

Curb Height (in.)	Curb Length (in.)	Curb Width (in.)	Material	Finish Type	Duct Adapter	Curb Weight (lb)
14	190.6	61.6	Galvanized	Galvanized	Yes	325

### Standard Construction Features:

All dimensions shown are actual and in units of in.'s
If unit is selected with side or end discharge/return, there will not be bottom connections supplied with the curb.
14 gauge galvanized steel (perimeter channels).
14 gauge galvanized steel (interior channels).
Ships knocked down for field assembly.
Curb insulation to be provided by others.

Curb Detail

### Top View of Curb

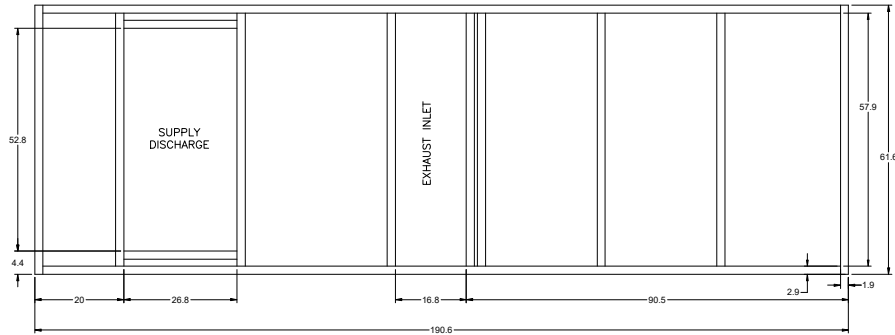

### Cross-Section View of Unit on Curb

