



4401 Springfield St.  
Dayton, OH 45431  
OH LIC # 24297  
937.254.3235  
800.254.9455  
msdinc.net

## SUBMITTAL COVER SHEET

### PROJECT

220390 Mercantile Library Building

### ENGINEER

KLH Engineers

### ARCHITECT

### SPECIFICATIONS NO.

### ITEM

Hydronic Pumps

Submittal # 02.1

- Approved  
 Disapproved

Date: 11/17/2022

Submitted by: Reed Hanes

Approved as noted per  
KHL's comments in  
email on page 2.  
-Jim Verlander, MSD

**From:** [Patrick Fernbach](#)  
**To:** [Reed Hanes](#); [Jim Verlander](#)  
**Cc:** [Mike Schulte](#); [Zach Wagner](#); [Margaret Norbut](#)  
**Subject:** RE: Mercantile Library Submittals  
**Date:** Friday, December 2, 2022 3:49:41 PM

---

Reed & Jim,

I already discussed these comments with Stoermer, but for everyone's records. Stoermer should be sending over record submittals, but this should get us through submittal and get this equipment ordered.

01.1 Dirt and Air Separator, Expansion Tank

DAS-1

No exceptions.

ET-1 and ET-2

Please make minimum flow temperature 50F and verify size of expansion tank is sufficient for the system.

02.1 Hydronic Pumps

HW-1 & 2

Please make power supply 208/3 as previously discussed.

Please size for 250 GPM. This was updated previously during design and coordinated. Please confirm most accurate submittal is received.

CWP-1 & 2

Please make power supply 208/3 as previously discussed.

Library Circulator

We will need. Just got confirmation this week. Please add back in.

03.1 WSHP

Please include WSHP-13 as previously sent.

WSHP-X01

Thermostat and controls by MSD controls team. Submittal is correct.

WSHP-C, WSHP-X03, WSHP-X08, WSHP-X09, WSHP-X05

Thermostat and controls by MSD controls team. Submittal is correct.

WSHP-X02, WSHP-X04, WSHP-X06

Thermostat and controls by MSD controls team. Submittal is correct.

WSHP-2-1, 2-2, 2-3, 2-4

Thermostat and controls by MSD controls team. Submittal is correct.

WSHP-2-5

Thermostat and controls by MSD controls team. Submittal is correct.

WSHP-X07

Thermostat and controls by MSD controls team. Submittal is correct.

04.1 Condensing Boilers

No exceptions.

05.1 Fluid Cooler

No exceptions.

DOAS/ERV not included.

(not included but DOAS EWT listed as 45F)

06.1 VFDs

HW Pump – 1,2

Please update to 3HP to match pump selection.

Thanks,

**Patrick Fernbach WELL AP**

Director of Mechanical Engineering

Kohrs Lonnemann Heil Engineers, Inc.



O : 859-547-0135

[www.klhengrs.com](http://www.klhengrs.com)

---

**From:** Reed Hanes <rhanes@msdinc.net>

**Sent:** Monday, November 21, 2022 8:26 AM

**To:** Patrick Fernbach <pfernbach@KLHENGERS.COM>

**Cc:** Jim Verlander <jverlander@msdinc.net>

**Subject:** Mercantile Library Submittals

Patrick,

Please see attached submittals for Mercantile Library.

Thanks,

Reed Hanes

Assistant Project Manager | MSD, Inc. |

C: 937-203-6953 E: [rhanes@msdinc.net](mailto:rhanes@msdinc.net)



**Gazelle Mechanical**  
10468 Chester Road  
Cincinnati, OH 45246  
888.991.7447  
[info@gazellemechanical.com](mailto:info@gazellemechanical.com)

## SUBMITTAL DATA

Project: 4<sup>th</sup> & Walnut-Library Building Date: November 11, 2022

Specification Section: N/A Original or Rev.#: Original

Manufacturer: Armstrong Item Description: Pumps

Engineer: KLH Engineers  
1538 Alexandria Pike, Ste. 11  
Fort Thomas, KY 41075

Construction Manager:

Mechanical Contractor: Mechanical Services & Design  
4401 Springfield St.  
Dayton, OH 45431

# Submittal

Ref. #: SQFNP002163\_1

close-coupled vertical in-line pump

**Model:** Series 4380 - 6x6x8 - 6p - 5 hp - (Factory Choice Motor) with Suction Guide and Flo-Trex Valve

<b>Project name:</b>	<b>Representative:</b> Mike Schulte
<b>Location:</b>	<b>Phone number:</b>
<b>Date submitted:</b> 10/6/2022 6:56 PM	<b>e-mail:</b> mas@stoermer-anderson.com
<b>Engineer:</b>	<b>Submitted by:</b> Schulte, Mike

## Application design data

Tag number:	HW-1 & 2	Configuration:	Single
Service:		Suction pressure:	0 ft
Location:		Fluid:	Non-Potable Fluid - Water
Qty:	2	Operating temperature:	60 °F
Total system flow:	500 USgpm	Duty flow per pump:	500 USgpm
System head:	25 ft	Viscosity:	31 SSU
Total dissolved solids:	0 ppm	Specific gravity:	1.0000
NPSHR:	4.57 ft	Absorbed Power/BHP:	4.04 hp
%Mtr Safety*:	23.73%	Efficiency at Design:	78.11 %
Outlet velocity:	5.55 ft/s	Impeller diameter:	8.18 in
PEIcl:	Not applicable	ERcl:	Not applicable
Standby qty:	0	Pump/motor run qty:	1

\*Motor safety factor above duty point.

## Materials of construction

Construction:	Bronze Fitted	Impeller:	Bronze
Rating:	ANSI-125	Casing gasket:	Confined Non-Asbestos Fiber
Connections:	Inlet: 6 in, Outlet: 6 in	Flush line:	Braided Stainless Steel
Casing (volute):	Cast Iron, E-coated	Shaft sleeve:	316 Stainless Steel

## Mechanical seal data

Seal type:	Inside Single Spring	Rotating face:	Resin Bonded Carbon
Manufacturer code:	C-ssc L EPSS 2A	Stationary seat:	Sintered Silicon Carbide
Springs:	Stainless Steel	Secondary seal:	EPDM
Rotating hardware:	Stainless Steel	Maximum total dissolved solids (TDS)*:	2000 PPM

\*Note: Please ensure proper seal is selected by inputting Total Dissolved Solids (TDS) in PPM in ADEPT if water quality is poor at site. Also select Flush Line Filter or Cyclone Separator if there are other contaminants in the fluid.

## Electrical data

Supplier:	Factory Choice	Insulation class:	Class F Insulation
Frame size:	215JP	Motor type:	Induction
Speed:	1177 rpm	Size:	5 hp
Enclosure:	ODP	Efficiency:	NEMA Premium 12.12
Power supply:	460/3/60		

## Operating limits (temperature - pressure)

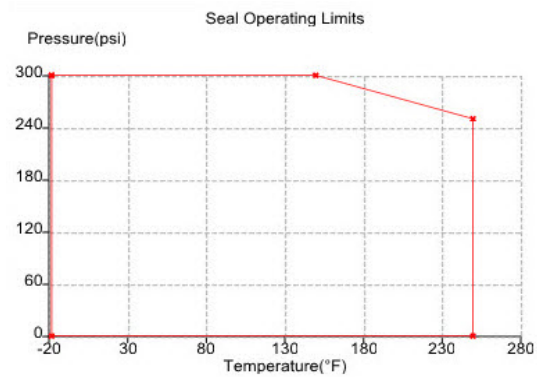
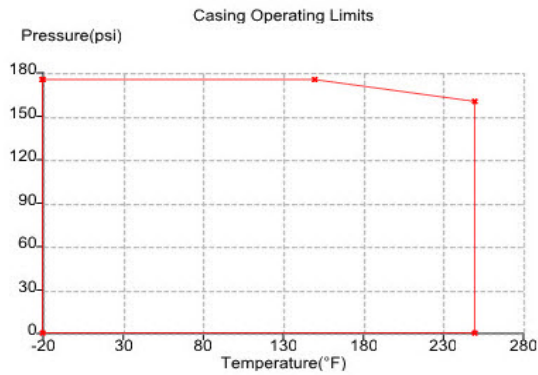

**Maximum pressure:** 175 psi

**Maximum temperature:** 250F

All Pump casings are hydrostatically tested to requirements of ANSI/HI 14.6 standard.

## Performance curve

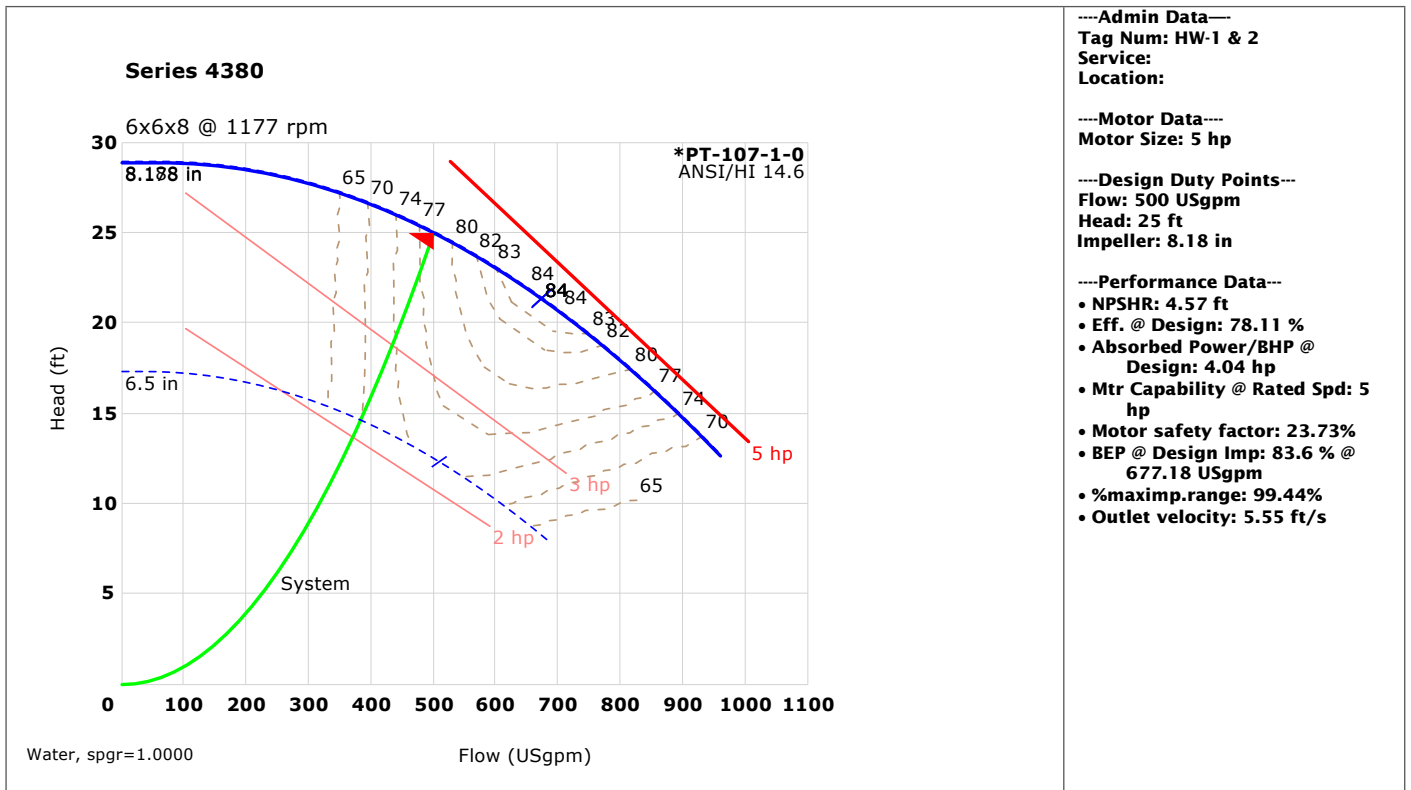

---Admin Data---  
Tag Num: HW-1 & 2  
Service:  
Location:

---Motor Data---  
Motor Size: 5 hp

---Design Duty Points---  
Flow: 500 USgpm  
Head: 25 ft  
Impeller: 8.18 in

---Performance Data---

- NPSHR: 4.57 ft
- Eff. @ Design: 78.11 %
- Absorbed Power/BHP @ Design: 4.04 hp
- Mtr Capability @ Rated Spd: 5 hp
- Motor safety factor: 23.73%
- BEP @ Design Imp: 83.6 % @ 677.18 USgpm
- %maximp.range: 99.44%
- Outlet velocity: 5.55 ft/s

## Dimensional data (not for construction)

Side view

Top view

R: 4.00  
[102]

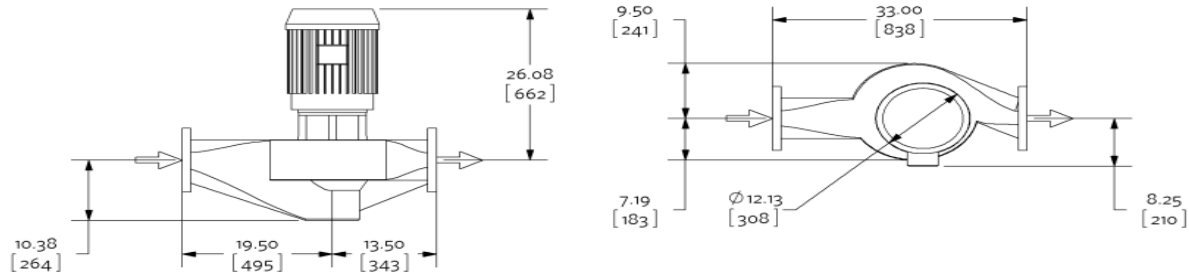

Inverter motor type: Inverter duty

Weight: 513 lb [232.69 kg], Units of measure: inches [millimeters]

- Not to scale
- R = minimum lifting clearance required above motor
- Coupling guard and flush line (not shown) are supplied
- Tolerance of  $\pm 0.125$  inch ( $\pm 3$  mm) should be used
- For certified dimensions, please contact your Armstrong representative
- Pump equipped with casing drain plug and  $\frac{1}{4}$  inch NPT suction and discharge gauge ports

### Connection details

Connection	Size	Rating	OD	Bolt quantity*	BCD	Bolt size
Inlet	6	ANSI-125	11.00	8	9.50	0.75
Outlet	6	ANSI-125	11.00	8	9.50	0.75

\*Equally spaced straddling centreline

### Special instructions

Reference Motor Specification AES 05007.

### Selected options

Testing: No Test Certification Required  
 Seal Environment Accessories: None  
 Space Heater: No  
 Motor Thermistor: No Thermistors  
 Wye-Delta Starting: No

## Submittal

Ref. #: SQFNP002163\_1

### Suction guide

#### Model: SG-66

<b>Project name:</b>	<b>Representative:</b> Mike Schulte
<b>Location:</b>	<b>Phone number:</b>
<b>Date submitted:</b> 10/6/2022 6:56 PM	<b>e-mail:</b> mas@stoermer-anderson.com
<b>Engineer:</b>	<b>Submitted by:</b> Schulte, Mike

#### Application design data

Tag	Qty	Model	Pipe Conn.size	Pump Conn.size	Design flowrate	Pressure Drop*	Associated pump
HW-1 & 2	2	SG-66	6 in	6 in	500 USgpm	0.74 ft	4380 - 6x6x8 - 6p - 5 hp - (Factory Choice Motor)

\*at design flow

#### Materials of construction

##### SG-66

Body:	Cast iron	Cover gasket:	Synthetic fiber
Guide vanes:	Cast iron	Strainer:	Stainless Steel,0.125"(3mm)Perf..
Cover plate:	Cast iron	Start-up strainer*:	Fine Mesh Galvanized Steel

\*Remove start up strainer after 24 hours of pump operation

#### Operating limits (temperature - pressure)

##### SG-66-Suction Guide-ANSI-125

###### PRESSURE TEMPERATURE LIMITS

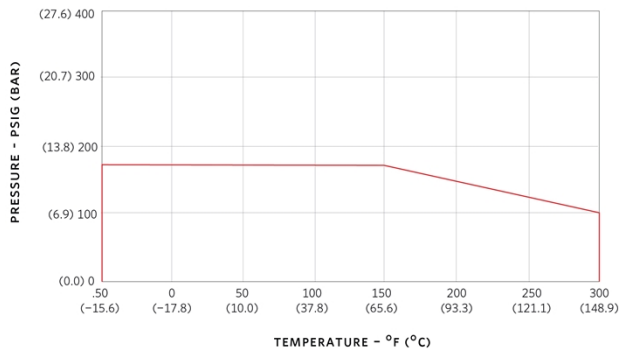

**Maximum pressure:** 175 psi  
**Maximum temperature:** 300 F

Units are hydrostatically tested to 150% of maximum working pressure

## Dimensional data (not for construction)

SG-66

Weight: 141 lb [63.96 kg]

Side view

Top view

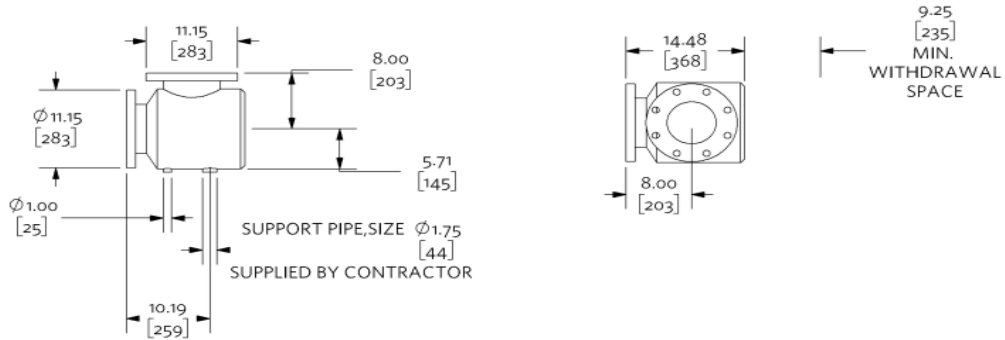

Not to scale

Units of measure: inches [millimeters]

Tolerance of +/- 0.125 inch (+/- 3 mm) should be used

For certified dimensions, please contact your Armstrong representative

# Submittal

Ref. #: SQFNP002163\_1

## long-coupled horizontal base-mounted end suction pump

**Model:** Series 4030 - 5x4x10 - 4p - 15 hp - (Factory Choice Motor) with Suction Guide and Flo-Trex Valve

<b>Project name:</b>	<b>Representative:</b> Mike Schulte
<b>Location:</b>	<b>Phone number:</b>
<b>Date submitted:</b> 10/6/2022 6:56 PM	<b>e-mail:</b> mas@stoermer-anderson.com
<b>Engineer:</b>	<b>Submitted by:</b> Schulte, Mike

### Application design data

Tag number:	CWP-1 & 2	Configuration:	Single
Service:		Suction pressure:	0 ft
Location:		Fluid:	Non-Potable Fluid - Water
Qty:	2	Operating temperature:	60 °F
Total system flow:	500 USgpm	Duty flow per pump:	500 USgpm
System head:	70 ft	Viscosity:	31 SSU
Total dissolved solids:	0 ppm	Specific gravity:	1.0000
NPSHR:	9.36 ft	Absorbed Power/BHP:	10.65 hp
%Mtr Safety*:	40.82%	Efficiency at Design:	82.98 %
Outlet velocity:	12.6 ft/s	Impeller diameter:	8.75 in
PEIcl:	0.94	ERcl:	6
Standby qty:	0	Pump/motor run qty:	1

\*Motor safety factor above duty point.

### Materials of construction

Construction:	Bronze Fitted	Impeller:	Bronze
Rating:	ANSI-125	Pump shaft:	Carbon Steel
Connections:	Inlet: 5 in, Outlet: 4 in	Shaft sleeve:ea	304 SS
Casing (volute):	Cast Iron, E-coated	Flexible coupling:	Sureflex
Bearings:	Anti-Friction Grease Lubricated	Casing gasket:	Confined Non-Asbestos Fiber
Drip pan:	No		

### Mechanical seal data

Seal type:	Inside Single Spring	Rotating face:	Resin Bonded Carbon
Manufacturer code:	C-ssc L EPSS 2A	Stationary seat:	Sintered Silicon Carbide
Springs:	Stainless Steel	Secondary seal:	EPDM
Rotating hardware:	Stainless Steel	Maximum total dissolved solids (TDS)*:	2000 PPM

\*Note: Please ensure proper seal is selected by inputting Total Dissolved Solids (TDS) in PPM in ADEPT if water quality is poor at site. Also select Flush Line Filter or Cyclone Separator if there are other contaminants in the fluid.

### Electrical data

Supplier:	Factory Choice	Insulation class:	Class F Insulation
Frame size:	254TC	Motor type:	Induction
Speed:	1780 rpm	Size:	15 hp
Enclosure:	ODP	Efficiency:	NEMA Premium 12.12
Power supply:	460/3/60		

## Operating limits (temperature - pressure)

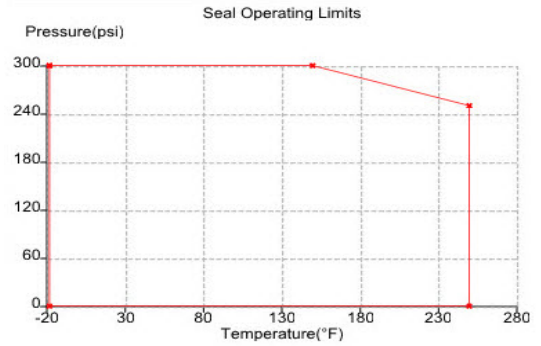
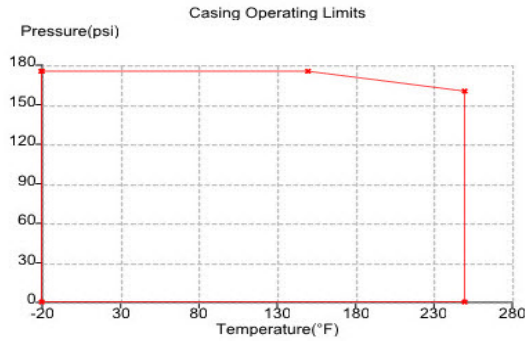

**Maximum pressure:** 175 psi

**Maximum temperature:** 250 F

All Pump casings are hydrostatically tested to requirements of ANSI/HI 14.6 standard.

## Performance curve

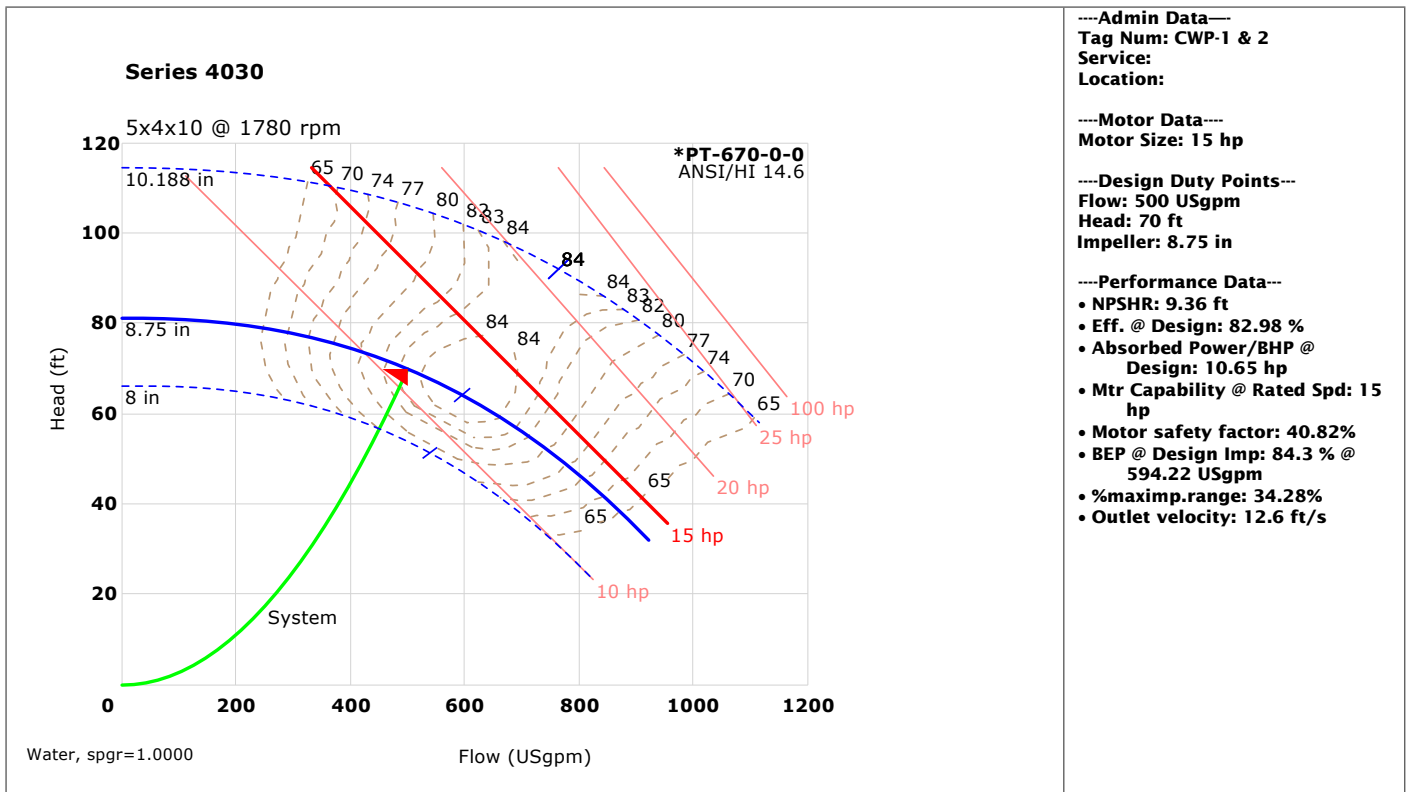

## Dimensional data (not for construction)

Side view

Top view

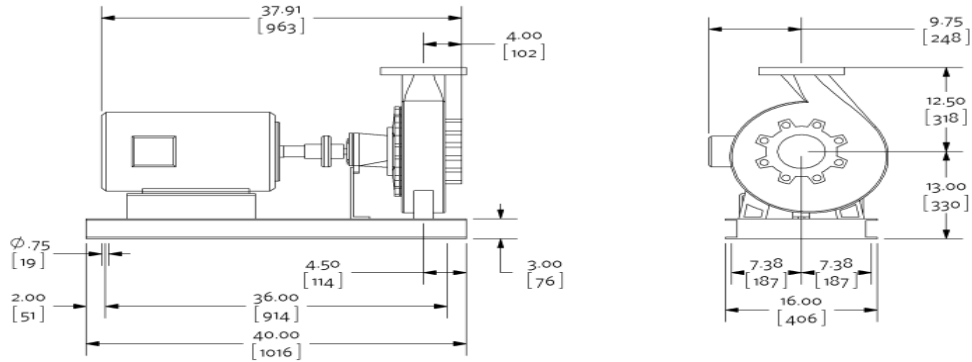

Inverter motor type: Inverter duty

Weight: 544 lb [246.75 kg], Units of measure: inches [millimeters]

- Not to scale
- Tolerance of  $\pm 0.125$  inch ( $\pm 3$  mm) should be used
- For certified dimensions, please contact your Armstrong representative
- Pump equipped with casing drain plug and  $\frac{1}{4}$  inch NPT suction and discharge gauge ports

### Connection details

Connection	Size	Rating	OD	Bolt quantity*	BCD	Bolt size
Inlet	5	ANSI-125	10.00	8	8.50	0.75
Outlet	4	ANSI-125	9.00	8	7.50	0.625

\*Equally spaced straddling centreline

### Special instructions

Reference Motor Specification AES 05007.

### Selected options

Testing: No Test Certification Required  
 Seal Environment Accessories: None  
 Couplings: Sureflex  
 Space Heater: No  
 Motor Thermistor: No Thermistors  
 Wye-Delta Starting: No  
 Drip Pan: No  
 Bearing Current Handling: Armstrong Choice Shaft Ground

## Submittal

Ref. #: SQFNP002163\_1

### Suction guide

#### Model: SG-55

<b>Project name:</b>	<b>Representative:</b> Mike Schulte
<b>Location:</b>	<b>Phone number:</b>
<b>Date submitted:</b> 10/6/2022 6:56 PM	<b>e-mail:</b> mas@stoermer-anderson.com
<b>Engineer:</b>	<b>Submitted by:</b> Schulte, Mike

#### Application design data

Tag	Qty	Model	Pipe Conn.size	Pump Conn.size	Design flowrate	Pressure Drop*	Associated pump
CWP-1 & 2	2	SG-55	5 in	5 in	500 USgpm	1.7 ft	4030 - 5x4x10 - 4p - 15 hp - (Factory Choice Motor)

\*at design flow

#### Materials of construction

##### SG-55

Body:	Cast iron	Cover gasket:	Synthetic fiber
Guide vanes:	Cast iron	Strainer:	Stainless Steel,0.125"(3mm)Perf..
Cover plate:	Cast iron	Start-up strainer*:	Fine Mesh Galvanized Steel

\*Remove start up strainer after 24 hours of pump operation

#### Operating limits (temperature - pressure)

##### SG-55-Suction Guide-ANSI-125

###### PRESSURE TEMPERATURE LIMITS

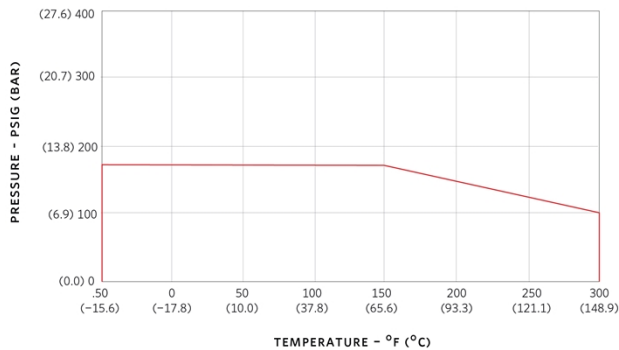

**Maximum pressure:** 175 psi  
**Maximum temperature:** 300 F

Units are hydrostatically tested to 150% of maximum working pressure

**Dimensional data (not for construction)**

SG-55

Weight: 99 lb [44.91 kg]

Side view

Top view

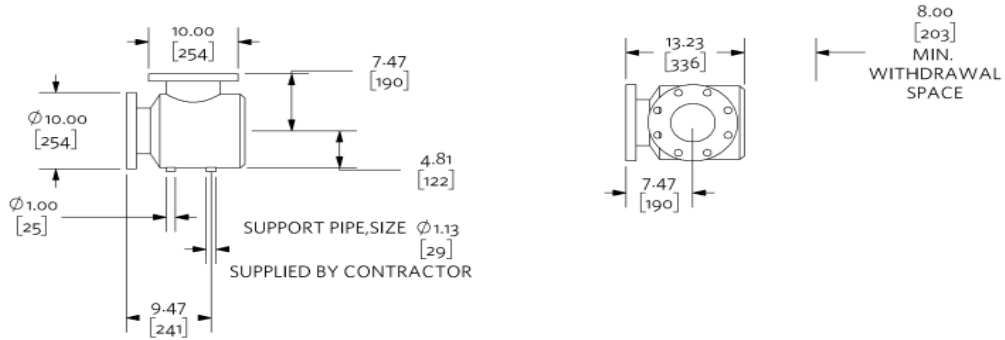

Not to scale

Units of measure: inches [millimeters]

Tolerance of +/- 0.125 inch (+/- 3 mm) should be used

For certified dimensions, please contact your Armstrong representative

# Submittal

Ref. #: SQFNP002163\_1

## Series H ECM in-line circulator

**Model:** Series H ECM-H64 ECM-0.75 hp

<b>Project name:</b>	<b>Representative:</b> Mike Schulte
<b>Location:</b>	<b>Phone number:</b>
<b>Date submitted:</b> 10/6/2022 6:56 PM	<b>e-mail:</b> mas@stoermer-anderson.com
<b>Engineer:</b>	<b>Submitted by:</b> Schulte, Mike

### Application design data

Tag number:	Library Circulator	Pipe orientation:	Single
Service:		Suction pressure:	0 ft
Location:		Fluid:	Non-Potable Fluid - Water
Quantity:	1	Operating temperature:	60 °F
Duty flow per pump:	20 USgpm	Viscosity:	31 SSU
Duty head:	40 ft	Specific gravity:	1.00
Total dissolved solids:	0 ppm	Absorbed Power/BHP:	N/A
NPSHR:	1 ft	Impeller diameter:	7.17 in
PEIvl:	Not applicable	ERvl:	Not applicable
Outlet velocity:		Efficiency at Design:	N/A

### Materials of construction

Construction:	Bronze Fitted	Impeller:	Non-Ferrous
Rating:	ANSI-125	Bearings:	Oil Lubricated
Connections:	Inlet:1.5 in, Outlet:1.5 in		

### Mechanical seal data

Seal type:	Inside Single Spring	Rotating face:	Carbon
Manufacturer code:	Armseal, Circs	Stationary seat:	Silicon Carbide
Springs:	Stainless Steel	Secondary seal:	BUNA-N
Rotating hardware:	Brass	Maximum total dissolved solids (TDS)*:	2000 PPM

\*Note: Please ensure proper seal is selected by inputting Total Dissolved Solids (TDS) in PPM in ADEPT if water quality is poor at site. Also select Flush Line Filter or Cyclone Separator if there are other contaminants in the fluid.

### Motor electrical data

Supplier:	Factory Choice	Insulation class:	Class F Insulation
Size:	0.75 hp	Inverter motor type:	[none]
Frame size:	Not applicable	Efficiency:	ECM
Enclosure:	ODP	Speed:	1750 rpm
Motor power supply:	115/1/60		

## Operating limits (temperature - pressure)

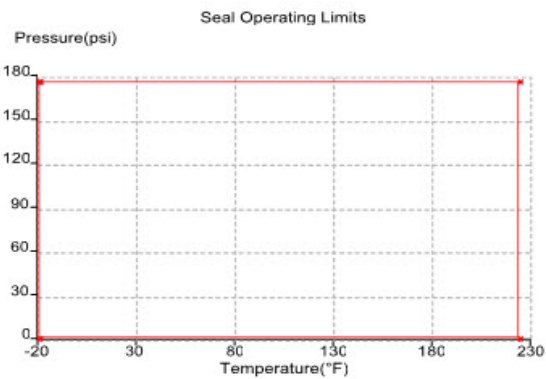
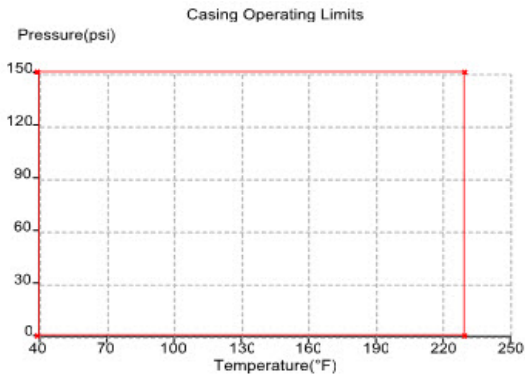

**Maximum pressure:** 175 psi

**Maximum temperature:** 225 °F

All Pump casings are hydrostatically tested to requirements of ANSI/HI 14.6 standard.

## Performance curve

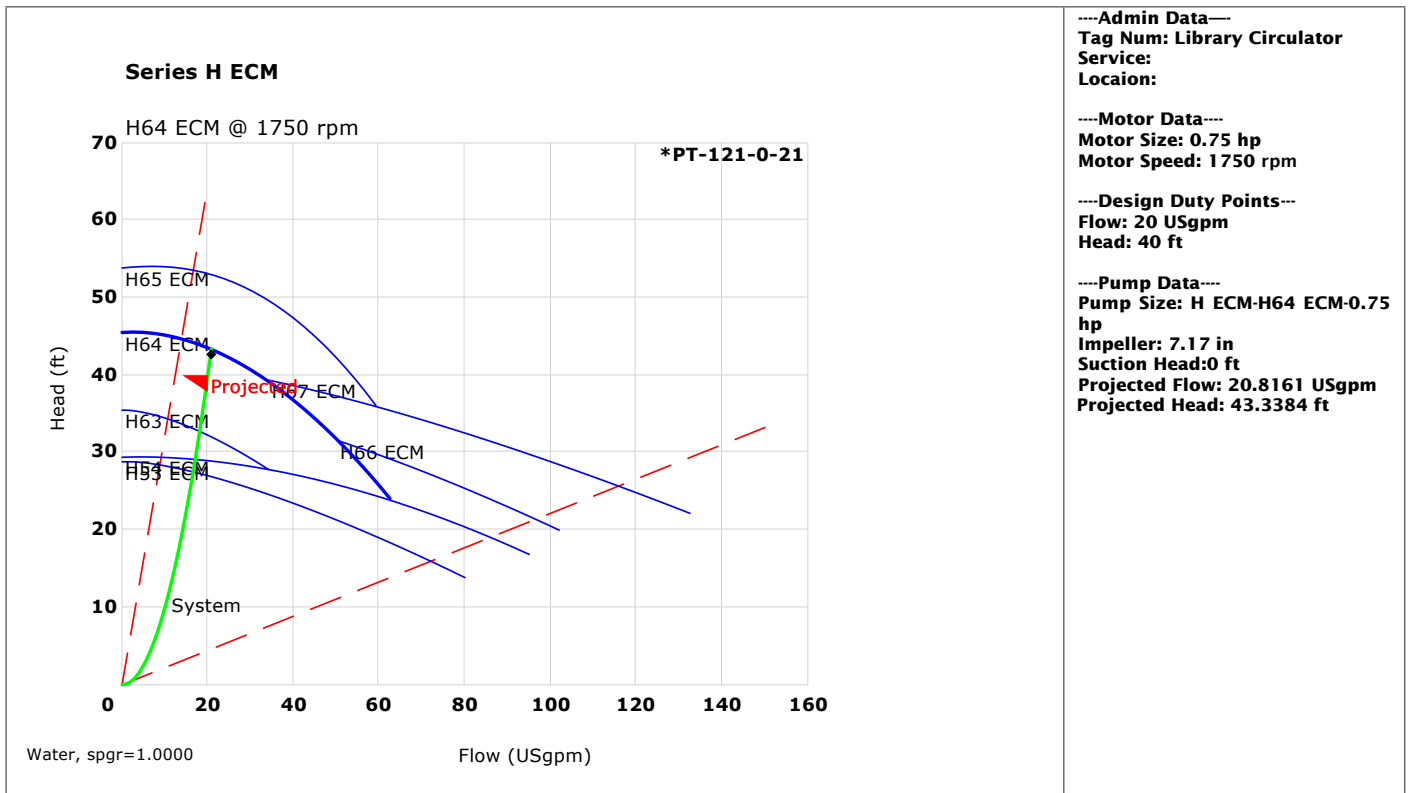

---Admin Data---  
**Tag Num:** Library Circulator  
**Service:**  
**Locaion:**

---Motor Data---  
**Motor Size:** 0.75 hp  
**Motor Speed:** 1750 rpm

---Design Duty Points---  
**Flow:** 20 USgpm  
**Head:** 40 ft

---Pump Data---  
**Pump Size:** H ECM-H64 ECM-0.75 hp  
**Impeller:** 7.17 in  
**Suction Head:** 0 ft  
**Projected Flow:** 20.8161 USgpm  
**Projected Head:** 43.3384 ft

## Dimensional data (not for construction)

Side view

Top view

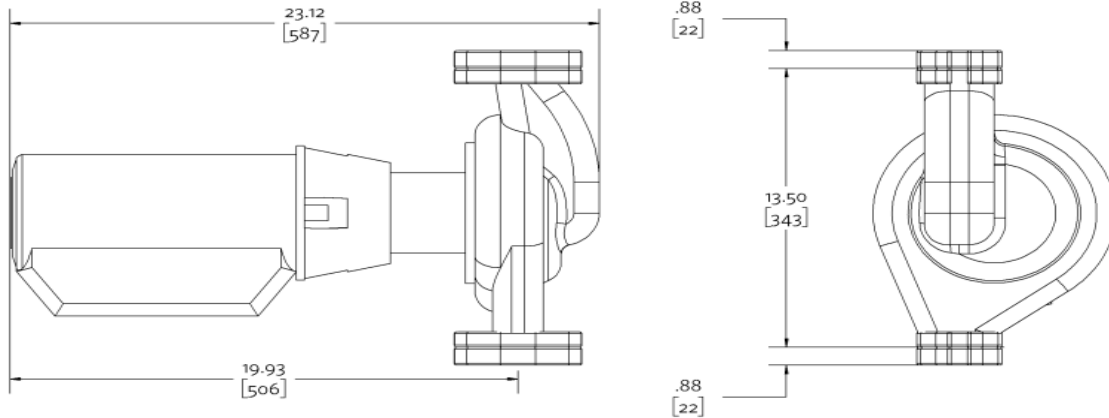

Weight: 95 lb [43.09 kg], Units of measure: inches [millimeters]

- Not to scale
- Tolerance of  $\pm 0.125$  inch ( $\pm 3$  mm) should be used
- For certified dimensions, please contact your Armstrong representative

### Connection details

Connection	Size	Rating	OD	Bolt quantity*	BCD	Bolt size
Inlet	1.5	ANSI-125	5.00	4	3.88	0.5
Outlet	1.5	ANSI-125	5.00	4	3.88	0.5

\*Equally spaced straddling centreline