

2300218

To: John Nimry GHAFARI Associates, L.L.C. 122 S Michigan Ave Chicago, IL 60603 Attn: Submittals Processing Phone: 313-984-2300 Fax: 313-984-8248 Email: jnimry@ghafari.com	From: Messer Construction Co. 9710 Bunsen Parkway, Louisville, KY 40299 Attn: Joe Metzger Phone: 502-918-0918 Fax: Email: jmetzger2@messer.com	3. Date Submitted: 10/30/24 4. Submittal No. 1 5. <input checked="" type="checkbox"/> New <input type="checkbox"/> Resubmittal 6. Specification Section No. 237423.13 7. GHAFARI Project No. 2300218 8. Project Title: DHL Aircraft Maintenance Center Facility	
9. Copies	10. Item Description	11. Mfr/Contractor	12. Contractor's Remarks:
1	Packaged, Direct-Fired, Outdoor, Heating-Only - Direct Fired Air Handler - Product Data	Perfection Group	1. Perfection verify handedness prior to ordering 2. Provide insulated curb per MH7-00-01 note 6
The undersigned certifies that the above-submitted items have been reviewed in detail and are correct and in strict conformance with all requirements of the contract documents, except as otherwise noted. Note: Review of items submitted does not relieve contractor from complying with all requirements of the contract documents.			
13. Name of Contractor Messer Construction		Signature	

GHAFARI ASSOCIATES L.L.C - SUBMITTAL VERIFICATION SECTION			
If a discipline necessary for proper review is not listed, add to the distribution list and forward the submittal for review.		Comments: <div style="text-align: center; color: red; font-weight: bold; font-size: 1.2em;"> See all comments in red on following pages. </div> <div style="text-align: center; border: 1px solid black; background-color: yellow; padding: 2px; margin: 5px auto; width: fit-content;"> HVU-R01, 02, R04, R06, R07 PAGE 6 HVU-R03, R05 PAGE 9 </div>	
ACTION TAKEN			
	REVIEWED		
X	REVIEWED WITH COMMENTS		
	REVISE & RESUBMIT		
	FILE ONLY, NOT REVIEWED		
	NOT REQUESTED, NOT REVIEWED		
DISTRIBUTION			
	Architectural		Interior
	Civil		Landscape
	Structural		Tel/Data
X	Mechanical		Industrial
	Electrical		
Reviewed by & Date: V. Markovic 11/18/2024		REVIEW IS FOR GENERAL CONFORMANCE WITH THE DESIGN CONCEPT AND CONTRACT DOCUMENTS. THIS OFFICE ASSUMES NO RESPONSIBILITY FOR THE ACCURACY AND COMPLETENESS OF THE SUBMITTAL. THIS REVIEW DOES NOT RELIEVE THE CONTRACTOR OF RESPONSIBILITY FOR ANY DEVIATION FROM THE CONTRACT DOCUMENTS. IF THIS SUBMITTAL DOES NOT CONFORM TO THE GHAFARI CONSTRUCTION DOCUMENTS, SUBMIT A WRITTEN EXPLANATION OF THE VARIANCE.	

Messer SUBMITTAL SHEET

WeAreBuilding.

Messer Construction Co.

243900-000 - DHL - Aircraft Maintenance Center

Project: 243900-000

DHL - Aircraft Maintenance Center
410 Wendell H. Ford Blvd
Erlanger, KY
41018

Spec Section Num: 237423.13

Submittal: 1

Revision:

Package:

Date: 10/30/24

Submittal Title: Packaged, Direct-Fired, Outdoor, Heating-Only - Product Data

Submittal Detail: Direct Fired Air Handler

Response Due By:

Contractor:
Joe Metzger
Messer Construction

Contractor's Stamp

REVIEWED FOR SUBMITTAL Messer <small>WeAreBuilding.</small>
Submittal Number: <u>1</u>
Messer Job #: <u>243900-000</u>
Date: <u>10/30/24</u>
Reviewed By: <u>Joe Metzger</u>

Architect:

Architect's Stamp

Response:

Comment:

SUBMITTAL SHEET

DHL – Hanger Addition

410 Wendell H. Ford Blvd.
Erlanger, KY 41018

Architect: NA

Engineer: Ghafari

GC: Messer Construction

Title: Direct – Fired Air Handler cut sheet submittal
Resubmitted 10-29-24



Approved as Submitted
 Submitted for Approval
 Revise and Resubmit

Job # 241054
Date: 10-29-24

Signed: Eric J. Rice
Eric J. Rice



1100 Seven Mile Road NW
Comstock Park, MI 49321
800.536.3461

Submittal

Project number: 90007
Project name: OP 24-01-0084 DHL Kentucky
Representative:
Location:

Note: This submittal is based on equipment and options listed on the attachment(s) and represents our interpretation of your requirements. It is the representative's responsibility to review this submittal and verify that it meets the job specifications.

Project Information

Project name: OP 24-01-0084 DHL Kentucky

Location:

Owner:

Architect:

MEP firm:

Mechanical contractor:

Date: 10/22/2024

Product Summary

Qty	Model Description	Unit Size	Tag(s)
5	4000 Series - Direct-Fired Air Handler 4000 Series	Rapid 4054	AHU-01 HVU-R01, R02, R04, R06, R07
2	4000 Series - Direct-Fired Air Handler 4000 Series	Rapid 4054	AHU-02 HVU-R03, R05

NOTE: If any components specified in this document are unavailable at such time of a released order, we reserve the right to substitute items of similar or superior quality.

Use tags as indicated in mechanical set of drawings

HVU-R01 and R07 have ESP of 1.00 in.wc. This includes ductwork and 3-way diffuser at the end. Fan shall be 30 HP.

HVU-R02, R03, R04, R05 and R06 have ESP of 0.5 in.wc. This includes ductwork and 3-way diffuser at the end. Fan shall be 25 HP.

HVU-R03 and R05 have weather proof exhaust discharge hoods. While other units don't.

As noted in mechanical schedule: EXTERNAL STATIC PRESSURE DOES NOT INCLUDE HEATING EXCHANGER, FILTERS, MIXING BOX, OR CASING LOSSES.

Product Data: Direct-Fired Air Handler 4000 Series

Qty	Description	Model Number
5	Direct-Fired Air Handler 4000 Series	RE4054AH-RRLAOL-4AILS-NAHDB-DNZZBFZ-ZZZZZZZZZAZZ-ZCCZ-GJZZZZZZZZZ-BJSZZZZZZZZZZZZZZZZ-E

Tag(s): ~~AHU-01~~ **HVU-R01, R02, R04, R06, R07**
 (w/o weather proof exhaust discharge hood)

Selected Options

- RE Cabinet : Rapid Fan and Burner Sections
- 4054 Cabinet Size : Rapid 4054
- A Style : AM
- H Orientation : Horizontal
- R Discharge Location : Right discharge
- R Return Location : Right return
- L Controls Location : Left controls
- A Paint : Enamel Rapid Blue (RAL-7012)
- O Indoor/Outdoor : Outdoor
- 4 Voltage : 460/3/60
- AI Blower : 54" CW Airfoil Blower - Class I
- L Motor Size : 40 HP
- S Motor Options : ODP, premium efficiency
- N Fuel Type : Natural gas
- AH Burner : HMA2A - 3000
- D Manifold Size : 1.5" w/ regulator
- B Gas Train Options : FM Compliant
- D Insulation : Double wall Unit and Accessory Sections **Double wall insulated**
- N Filter Section : Filter mix box, right return
- Z Inlet Hood : None
- Z Duct Sleeves : None
- B Mounting Option : Curb supplied by Rapid™ / shipped ahead **Insulated roof curb**
- F Optional Dampers : Motorized premium low leak inlet damper only
- Z Cooling Option : None
- Z Energy Recovery : None
- A Vibration Isolation : Neoprene pad
- Z Service Platform : None
- Z Ladder : None
- Z Exhaust Mode : None
- C Controller : ICS IV
- C Controls Remote : ICS IV/InfinityPro Equipment Touch Remote
- Z Exhaust Fan VFD : None
- G Other Option : Extended grease lines (supply fan)
- J Other Option : Filters Polylink - Two Sets
- B Controls Options : GFCI 120V Duplex outlet + control cabinet light (powered by Rapid)
- J Controls Options : Filter status indicator
- S Controls Options : Smoke detector (shipped loose for field installation)
- E Discharge Accessories : 3- Way Discharge head horizontal and vertical blades

HVU-R01 - 30 HP
HVU-R02 - 25 HP
HVU-R04 - 25 HP
HVU-R06 - 25 HP
HVU-R07 - 30 HP

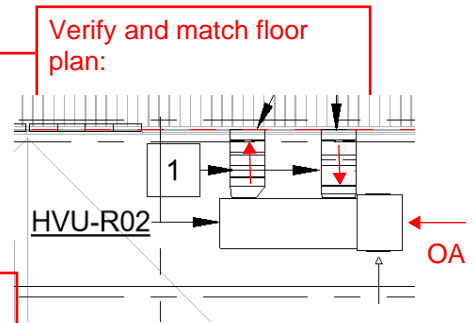

- Include SCCR 65 KA**
- Include MERV 9 pre filter and MERV 13 final filter**
- Include factory built-in starter**
- Include factory mounted non-fused disconnect**
- Include gas pressure regulator**



Rapid 4054

~~Tag: AHU-01~~

HVU-R01, R02, R04, R06, R07

(w/o weather proof exhaust discharge hood)

HVU-R01 and R07 have ESP of 1.00 in.wc.
 HVU-R02, R03, R04, R05 and R06 have ESP of 0.5 in.wc.

Unit Information

RE4054AH-RRLAOL

Model: 4000 Series

Unit Size: Rapid 4054

Quantity: 5

Altitude: 0 ft

Unit Voltage: 460/3/60

Heat Source: Natural gas

Gas Train: FM Compliant

Min Inlet Gas Pressure: 138.7 in.wg

Inlet Gas Pressure: 138.50 in.wg



Direct-Fired Air Handler 4000 Series

Air Handler Function (see top and side view images for actual orientation)

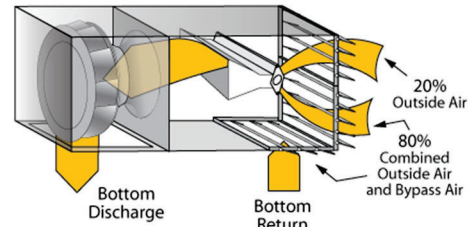

Performance Information

Airflow: 42000 CFM

Temperature Rise: 60 F

Output Capacity: 2721.6 MBH

Motor Information (For Each Blower)

Motor Type: ODP, premium efficiency

Motor HP: 40 HP

HVU-R01 - 30 HP
 HVU-R02 - 25 HP
 HVU-R04 - 25 HP
 HVU-R06 - 25 HP
 HVU-R07 - 30 HP

Pressure Information

Duct Static: ~~1.45~~ in.wg

ISP: 1.91 in.wg

TSP: 3.36 in.wg

Blower: BIAF 54 CW

Fan RPM: 664 - Total BHP: 31.26

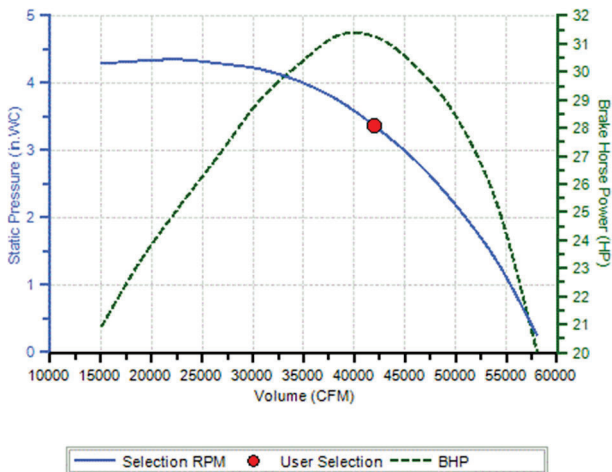

Top View

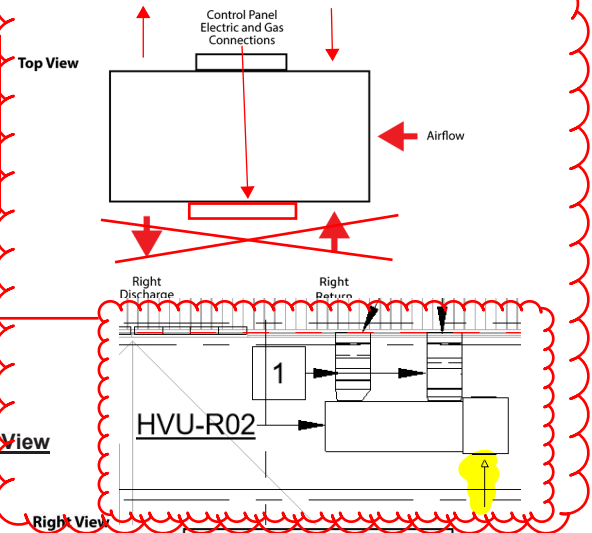

Side View

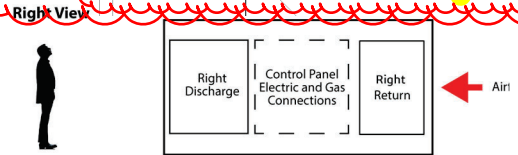

Per floor plan orientation looks different. Arrow shows the intake.

Supplemental Items

Name	ISP	Weight
Louvered Inlet Plenum	0.1	0
Additional Filter w/ MERV13	0.25	0
Extra Set of Belts	0	0

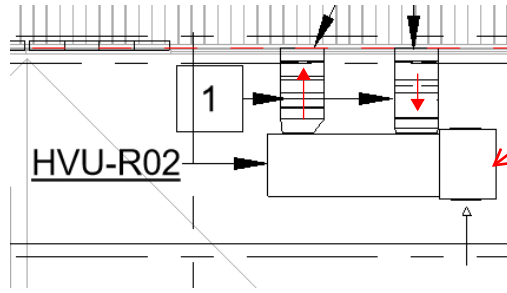

OA Intake

Units shall have intake, discharge and return per mechanical floor plan

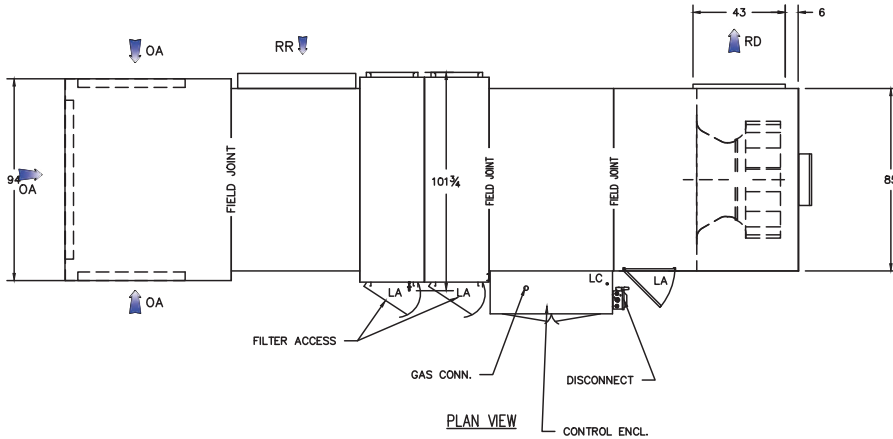

APPROVAL DRAWINGS	
Please sign & return one copy to:	SPECIFIED AIR 1100 SEVEN MILE RD. N.W. CONSTOCK PARK, MI 48321
This DWG & additional DWG's attached here to:	Approved by: _____
Company Name	Date

- NOTE: (1) CONTRACTOR/INSTALLER MUST MAKE APPROPRIATE ALLOWANCES FOR DUCT CONNECTIONS.
(2) ALL DIMENSIONS AND WEIGHTS ARE SUBJECT TO CHANGE WITHOUT NOTICE AND SHOULD NOT BE USED FOR CONSTRUCTION UNLESS CERTIFIED.

CODES:

- LC-LEFT CONTROLS
- RD-RIGHT DISCHARGE
- RR-RIGHT RETURN
- LA-LEFT ACCESS
- LE-LEFT EXHAUST AIR
- OA-OUTSIDE AIR

PRE-FILTERS:

- 1 SETS 55-20X20X2 MV7 POLY FILTERS

FINAL FILTERS:

- 1 SET 45-20X20X4 MV13 PLEATED FILTERS

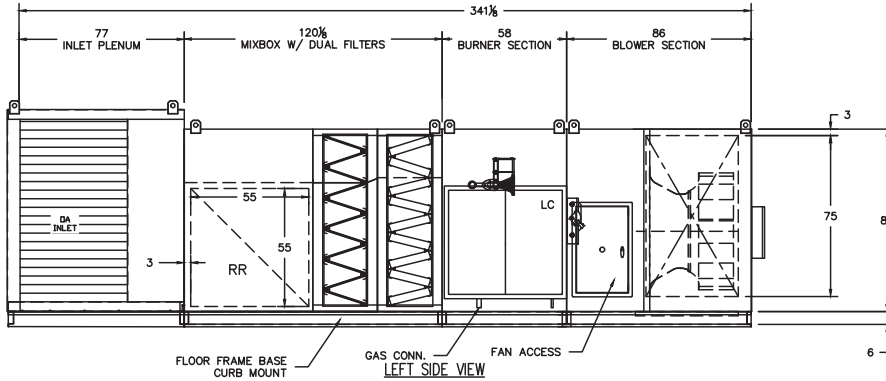

Approximate Shipping Weights (lbs.)			
Fan Section	Burner Section	Dual Filter Section & Mixing Box Section	Louvered Inlet Plenum
2,383	1,671	2,065	1,150

THIS SHEET IS FOR GENERAL INFORMATION PURPOSES ONLY. INFORMATION CAN CHANGE WITHOUT NOTICE AND SHOULD THEREFORE NOT BE USED FOR CONSTRUCTION OR INSTALLATION. ALL PRODUCTS MUST BE SET-UP, ASSEMBLED, INSTALLED AND USED IN ACCORDANCE WITH ALL APPLICABLE INSTRUCTIONS, THE PROVIDED INSTRUCTION MANUAL AS WELL AS REQUIREMENTS OF GOVERNMENTAL AUTHORITIES. THE INFORMATION ON THIS SHEET IS PROPRIETARY AND IS THE PROPERTY OF SPECIFIED AIR. © SPECIFIED AIR

REV.	ECO#	DATE	CK BY	DES	SCALE	DRAWN BY:	DATE:	REV.	DWG NO.
						DWD	10/21/24		24-01-0084A
Job:				SPECIFIED AIR					
Date: 10/21/2024 Tag#: -				4054 HAM W/ FILTER MIXBOX, 4" FILTER V-BANK & LOUVERED INLET PLENUM					
FILE LOCATION: HTR-SUB				PLOT RATIO:		CK BY: -		WO#	

Product Data: Direct-Fired Air Handler 4000 Series

Qty	Description	Model Number
2	Direct-Fired Air Handler 4000 Series	RE4054AH-RRLAOL-4AILS-NAHDB-DNZZBFZ-ZZZZZZZZZAZZ-DCCZ-GIZZZZZZZZ-BJSZZZZZZZZZZZZZZZZ-E

Tag(s): ~~AHU-02~~ **HVU-R03, R05** **RE4054AH-RRLAOL**
 (w/ weather proof exhaust discharge hood)

Selected Options

- RE Cabinet : Rapid Fan and Burner Sections
- 4054 Cabinet Size : Rapid 4054
- A Style : AM
- H Orientation : Horizontal
- R Discharge Location : Right discharge
- R Return Location : Right return
- L Controls Location : Left controls
- A Paint : Enamel Rapid Blue (RAL-7012)
- O Indoor/Outdoor : Outdoor
- 4 Voltage : 460/3/60
- AI Blower : 54" CW Airfoil Blower - Class I
- L Motor Size : 40 HP
- S Motor Options : ODP, premium efficiency
- N Fuel Type : Natural gas
- AH Burner : HMA2A - 3000
- D Manifold Size : 1.5" w/ regulator
- B Gas Train Options : FM Compliant
- D Insulation : Double wall Unit and Accessory Sections **Double wall insulated**
- N Filter Section : Filter mix box, right return
- Z Inlet Hood : None
- Z Duct Sleeves : None
- B Mounting Option : Curb supplied by Rapid™ / shipped ahead **Insulated roof curb**
- F Optional Dampers : Motorized premium low leak inlet damper only
- Z Cooling Option : None
- Z Energy Recovery : None
- A Vibration Isolation : Neoprene pad
- Z Service Platform : None
- Z Ladder : None
- D Exhaust Mode : With hood LE
- C Controller : ICS IV
- C Controls Remote : ICS IV/InfinityPro Equipment Touch Remote
- Z Exhaust Fan VFD : None
- G Other Option : Extended grease lines (supply fan)
- I Other Option : Filters Polylink - One Set
- B Controls Options : GFCI 120V Duplex outlet + control cabinet light (powered by Rapid)
- J Controls Options : Filter status indicator
- S Controls Options : Smoke detector (shipped loose for field installation)
- E Discharge Accessories : 3- Way Discharge head horizontal and vertical blades

Verify and match floor plan:

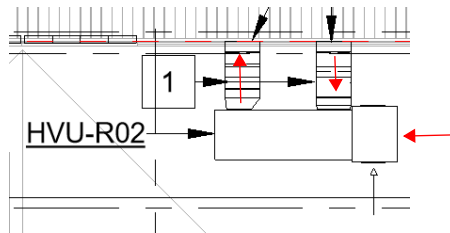

HVU-R03 - 25 HP
HVU-R05 - 25 HP

- Include SCCR 65 KA**
- Include MERV 9 pre filter and MERV 13 final filter**
- Include factory built-in starter**
- Include factory mounted non-fused disconnect**
- Include gas pressure regulator**



Rapid 4054

Tag: AHU-02

Unit Information

RE4054AH-RRLAOL
Model: 4000 Series

Unit Size: **Rapid 4054**

Quantity: **2**

Altitude: **0** ft

Unit Voltage: **460/3/60**

Heat Source: **Natural gas**

Gas Train: **FM Compliant**

Min Inlet Gas Pressure: **138.7** in.wg

Inlet Gas Pressure: **138.50** in.wg

HVU-R01 and R07 have ESP of 1.00 in.wc.
 HVU-R02, R03, R04, R05 and R06 have ESP of 0.5 in.wc.



Direct-Fired Air Handler 4000 Series

Air Handler Function (see top and side view images for actual orientation)

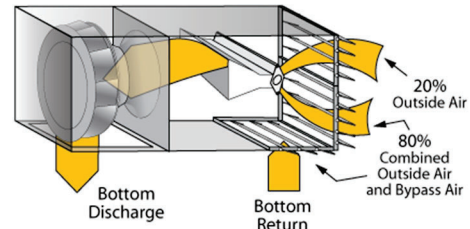

Performance Information

Airflow: **42000** CFM

Temperature Rise: **60** F

Output Capacity: **2721.6** MBH

Motor Information (For Each Blower)

Motor Type: **ODP, premium efficiency**

Motor HP: **40** HP

Pressure Information

Duct Static: **1.45** in.wg

ISP: **1.91** in.wg

TSP: **3.36** in.wg

HVU-R03 - 25 HP_{low}
 HVU-R05 - 25 HP

Blower: BIAF 54 CW

Fan RPM: 664 - Total BHP: 31.26

Match the floor plan

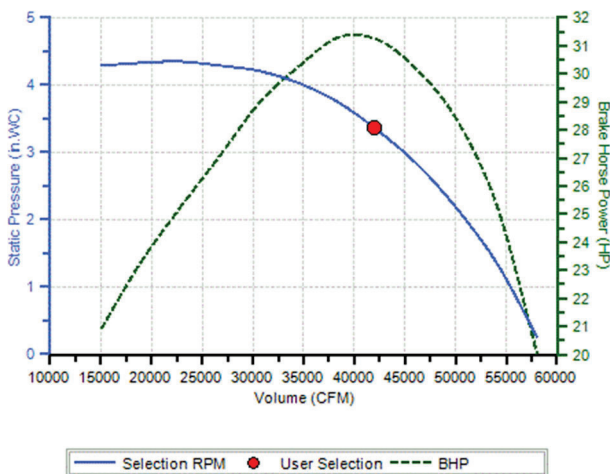

Top View

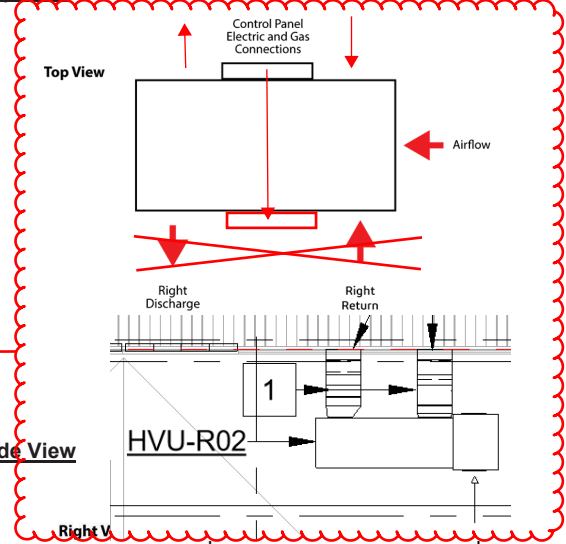

Side View

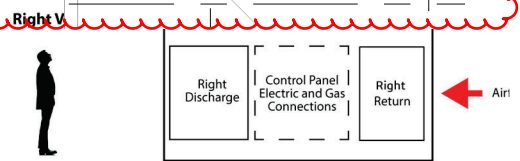

Supplemental Items

Name	ISP	Weight
Louvered Inlet Plenum	0.1	0
Additional Filter w/ MERV13	0.25	0
Extra Set of Belts	0	0

HVU-R03, R05

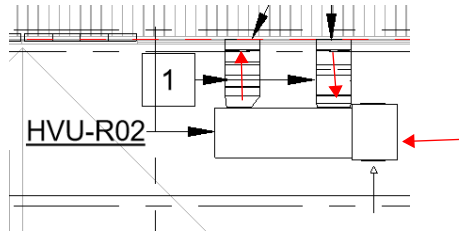

Units shall have intake, discharge and return per mechanical floor plan

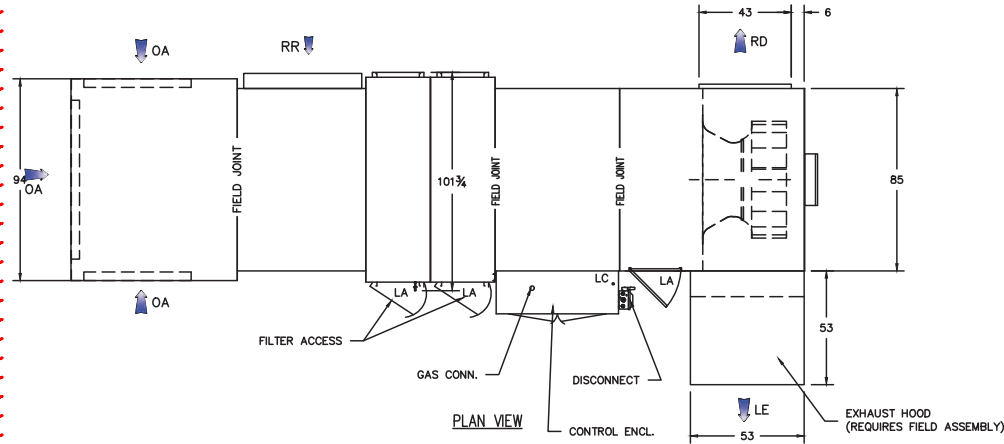

APPROVAL DRAWINGS

Please sign & return SPECIFIED AIR
one copy to: 1100 SEVEN MILE RD. N.W.
CONSTOCK PARK, MI 48321

This DWG & _____ additional DWG's attached here to.

Approved by: _____

Company Name _____ Date _____

- NOTE: (1) CONTRACTOR/INSTALLER MUST MAKE APPROPRIATE ALLOWANCES FOR DUCT CONNECTIONS.
- (2) ALL DIMENSIONS AND HEIGHTS ARE SUBJECT TO CHANGE WITHOUT NOTICE AND SHOULD NOT BE USED FOR CONSTRUCTION UNLESS CERTIFIED.

CODES:
 LC-LEFT CONTROLS
 RD-RIGHT DISCHARGE
 RR-RIGHT RETURN
 LA-LEFT ACCESS
 LE-LEFT EXHAUST AIR
 OA-OUTSIDE AIR

PRE-FILTERS:
 1 SETS 55-20X20X2 MV7 POLY FILTERS

FINAL FILTERS:
 1 SET 45-20X20X4 MV13 PLEATED FILTERS

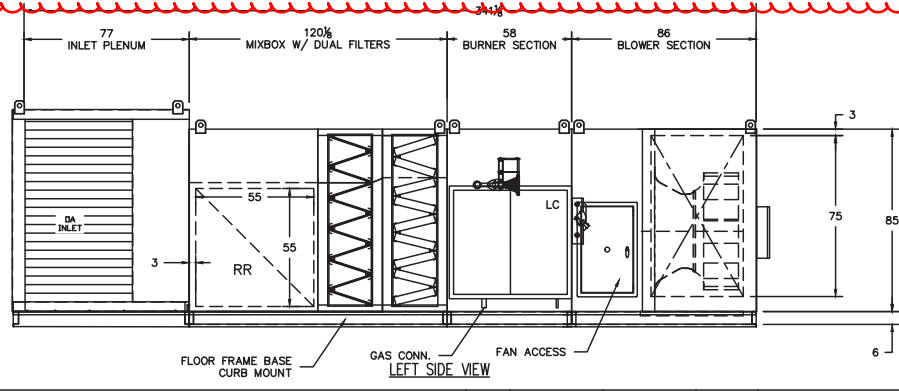

Approximate Shipping Weights (lbs.)				
Fan Section	Burner Section	Dual Filter Section & Mixing Box Section	Louvered Inlet Plenum	Exhaust Hood
2,383	1,671	2,065	1,150	300

THIS SHEET IS FOR GENERAL INFORMATION PURPOSES ONLY. INFORMATION CAN CHANGE WITHOUT NOTICE AND SHOULD THEREFORE NOT BE USED FOR CONSTRUCTION OR INSTALLATION. ALL PRODUCTS MUST BE SET-UP, ASSEMBLED, INSTALLED AND USED IN ACCORDANCE WITH ALL APPLICABLE INSTRUCTIONS, THE PROVIDED INSTRUCTION MANUAL AS WELL AS REQUIREMENTS OF GOVERNMENTAL AUTHORITIES. THE INFORMATION ON THIS SHEET IS PROPRIETARY AND IS THE PROPERTY OF SPECIFIED AIR. © SPECIFIED AIR

REV.	ECO#	DATE	CK BY	SPECIFIED AIR	
				4054 HAM W/ FILTER MIXBOX, 4" FILTER V-BANK LOUVERED INLET PLENUM & EXHAUST HOOD	
Job:				SCALE	DRAWN BY: DWD
Date: 10/21/2024 Tag#: -				DATE: 10/21/24	REV. DWG NO.
FILE LOCATION: HTR-SUB				PLOT RATIO:	CK BY: - WO#
					24-01-0084B

* MEASURE ROOF CURB ASSEMBLY TO ENSURE THE OD OF TOP MOUNTING SURFACES EQUALS DIMENSIONS SHOWN.

- NOTES:
- 1) ALL DIMENSIONS ARE IN O.D.
 - 2) CURB MATERIAL IS 14 GA GALV FOR MODELS 54 THRU 89 AND 16 GA GALV FOR MODELS 24 THRU 49.
 - 3) CURB IS SHIPPED KNOCKED DOWN.
 - 4) NUTS AND BOLTS (3/8" X 1") & CAULKING ARE FURNISHED. CAULK ALL JOINTS BEFORE ASSEMBLING.
 - 5) AIR HANDLER FIELD ASSEMBLY JOINTS MIGHT NOT FALL ON ROOF CURB JOINTS.

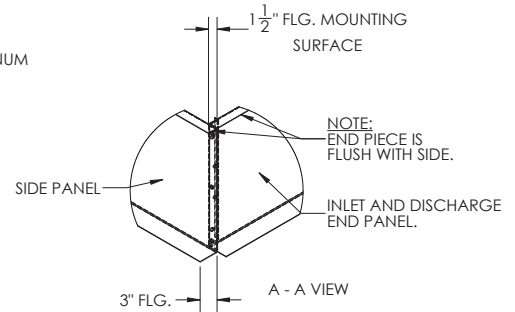
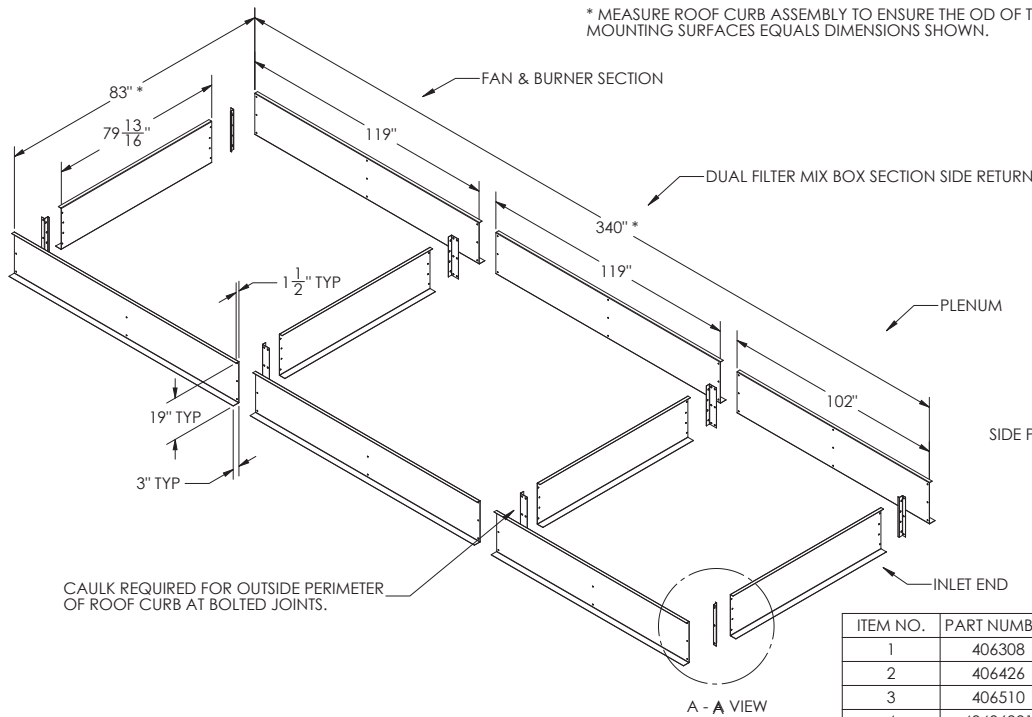

CAULK REQUIRED FOR OUTSIDE PERIMETER OF ROOF CURB AT BOLTED JOINTS.

Roof curbs shall be insulated

ITEM NO.	PART NUMBER	DESCRIPTION	QTY.
1	406308	RC END PANEL 19 X 79.8125 (4054)	4
2	406426	RC SIDE PANEL 19 X 119	4
3	406510	RC SIDE PANEL 19 X 102	2
4	40406301	RC CORNER BRACKET (NEW DESIGN)	4
5	40406302	ROOF CURB INTERMEDIATE BRACKET 18 5/16"	4
6	20513	NUT, FLANGE 3/8-16	80
7	20515	WASHER, FLAT 3/8	80
8	20517	H.H.C.S. 3/8-16X1	80
9	20897	CAULK, SIKAFLEX #221 TUBE	3

<p>SPECIFIED AIR SOLUTIONS</p> <p>1100 7 Mile Road, Comstock Park MI 49321-0700 www.rapidengineering.com</p>	<p>DRAWING DESCRIPTION</p> <p>ROOF CURB 54 F / B / DUAL FMB SR / P</p>	<p>TOLERANCES (UNLESS OTHERWISE NOTED)</p> <table border="1"> <tr> <td>MACH</td> <td>WELD</td> <td>FAB</td> </tr> <tr> <td>FRACTION</td> <td>1/32</td> <td>1/8</td> </tr> <tr> <td>DECIMAL</td> <td>.01</td> <td>.03</td> </tr> <tr> <td>ANGLE</td> <td>±.5</td> <td>±.2</td> </tr> </table>	MACH	WELD	FAB	FRACTION	1/32	1/8	DECIMAL	.01	.03	ANGLE	±.5	±.2
	MACH	WELD	FAB											
FRACTION	1/32	1/8												
DECIMAL	.01	.03												
ANGLE	±.5	±.2												
<p>WEIGHT(lbs)</p> <p>481.608</p>	<p>DO NOT SCALE DRAWING</p> <p>REMOVE BURRS & SHARP EDGES</p> <p>CHECKED BY:</p> <p>10/19/2024 JK</p>	<p>PRINTED DATE:</p> <p>10/19/2024</p> <p>DRAWN BY:</p> <p>10/19/2024 JK</p> <p>CREATION DATE:</p> <p>10/19/2024</p> <p>REV</p> <p>SHEET</p> <p>1 OF 1</p> <p>DATE PLOTTED:</p> <p>10/22/2024</p> <p>500-019114</p>												

ALL DIMENSIONS ARE IN INCHES UNLESS OTHERWISE SPECIFIED

This sheet is for general information purposes only. Information can change without notice and should therefore not be used for construction or installation. All products must be set-up, assembled, installed and used in accordance with all applicable instructions, the provided instruction manual as well as requirements of governmental authorities. The information on this sheet is proprietary and is the property of Rapid Engineering LLC.

APPROVAL DRAWINGS

Please sign & return **RAPID ENGINEERING LLC**
 one copy to: 1100 SEVEN MILE RD. N.W.
 COMSTOCK PARK, MI 49321

This DWG & _____ additional DWG's attached here to.

Approved by: _____

Company Name _____ Date _____

*NOTE: (1) CONTRACTOR/INSTALLER MUST
 MAKE APPROPRIATE ALLOWANCES
 FOR DUCT CONNECTIONS.

(2) ALL DIMENSIONS AND WEIGHTS
 ARE SUBJECT TO CHANGE
 WITHOUT NOTICE AND SHOULD
 NOT BE USED FOR CONSTRUCTION
 UNLESS CERTIFIED.

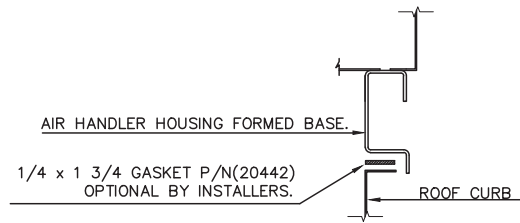

MODELS 24-66

(Standard Roof Curb)

THIS SHEET IS FOR GENERAL INFORMATION PURPOSES ONLY. INFORMATION CAN CHANGE WITHOUT NOTICE AND SHOULD THEREFORE NOT BE USED FOR CONSTRUCTION OR INSTALLATION. ALL PRODUCTS MUST BE SET-UP, ASSEMBLED, INSTALLED AND USED IN ACCORDANCE WITH ALL APPLICABLE INSTRUCTIONS, THE PROVIDED INSTRUCTION MANUAL AS WELL AS REQUIREMENTS OF GOVERNMENTAL AUTHORITIES. THE INFORMATION ON THIS SHEET IS PROPRIETARY AND IS THE PROPERTY OF RAPID ENGINEERING LLC. ©RAPID ENGINEERING LLC

Job: -

Date: - Tag#: -

REV.	ECO#	DATE	CK BY	RAPID ENGINEERING LLC				
C	-	02/19/03	KTD	C S D W N	AM, MUA, AR, VAV, HORIZ SUPPORT DETAILS.			
B	020005	12/26/02	KTD					
A	-	06/25/99	MAP					
FILE LOCATION: HTR-SUB				SCALE 12" = 1'	DRAWN BY: KTD	DATE: 2/4/98	REV. C	DWG NO. 50016500
				PLOT RATIO: 1:1	CK BY: -	WO# -		

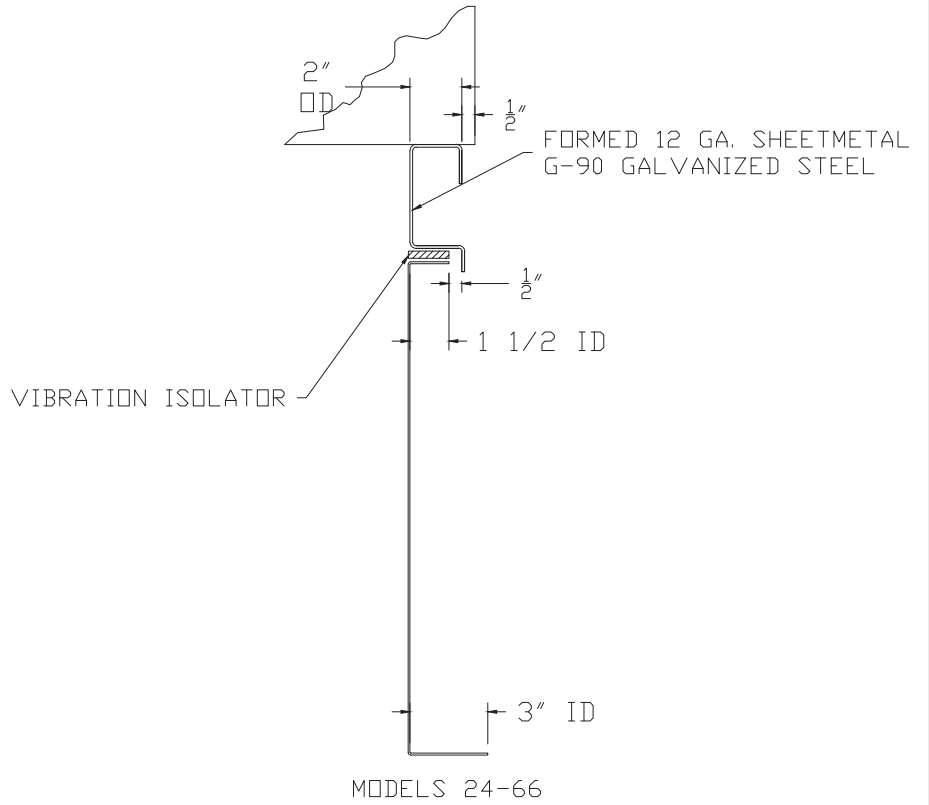

THIS SHEET IS FOR GENERAL INFORMATION PURPOSES ONLY. INFORMATION CAN CHANGE WITHOUT NOTICE AND SHOULD THEREFORE NOT BE USED FOR CONSTRUCTION OR INSTALLATION. ALL PRODUCTS MUST BE SET-UP, ASSEMBLED, INSTALLED AND USED IN ACCORDANCE WITH ALL APPLICABLE INSTRUCTIONS, THE PROVIDED INSTRUCTION MANUAL AS WELL AS REQUIREMENTS OF GOVERNMENTAL AUTHORITIES. THE INFORMATION ON THIS SHEET IS PROPRIETARY AND IS THE PROPERTY OF RAPID ENGINEERING LLC. ©RAPID ENGINEERING LLC

Job: -
Date: - Tag#: -

REV.	ECO#	DATE	CK BY	RAPID ENGINEERING LLC				
D	020005	02/14/03	KTD	C S W D	VIBRATION ISOLATOR, CURB MOUNTED			AT
C	-	9/25/99	MAP					
B	-	9/30/94	PJW	SCALE 12" = 1'		DRAWN BY: JLW	DATE: 2/1/89	REV. DWG NO.
FILE LOCATION: HTR-SUB				PLOT RATIO: 1:1		CK BY: KJI	WO# -	D 40001901



P8100 (SC 42-UL)

Neoprene / EPDM / SBR Closed Cell Foam Tape

TECHNICAL DATA

- Absorb shock and dampen sound and vibrations
- Provide a tight, long-lasting seal against moisture, dust, and air leaks
- Pass FMVSS302 and UL 94 HF1 for flammability
- Resist acids, alkali, ozone, and oxidation

Product Description

Pres-On P8100 (SC 42-UL) is a specification grade, black closed cell Neoprene/EPDM/SBR blend tape featuring a high-tack rubber based pressure sensitive adhesive (PSA) on one side with easy-to-use release liner.

NOTE: Also available with acrylic PSA on one-side (minimums may apply)

Applications

P8100 (SC 42-UL) is a general application tape recommended for gasketing and weatherproofing windows and doors.

STANDARD ROLL SIZE	SERIAL NUMBER	THICKNESS	LENGTH
P8100 (SC 42-UL) is available in widths from 1/4" to 54 inches wide.	P8106 (SC 42-UL)	1/16"	50'
	P8112 (SC 42-UL)	1/8"	50'
	P8118 (SC 42-UL)	3/16"	50'
	P8125 (SC 42-UL)	1/4"	50'
	P8137 (SC 42-UL)	3/8"	25'
	P8150 (SC 42-UL)	1/2"	25'
	P8175 (SC 42-UL)	3/4"	25'
	P811	1"	25'

ADHESION PROPERTIES	TEST	TYPICAL PERFORMANCE	TEST METHOD
High-tack pressure sensitive rubber based adhesive. One sided with release liner.	Adhesion to Steel @ 72°F Steel immediate	7 lbs/inch width or foam tear	PSTC-1
	Steel after 24 hours	8 lbs/inch width or foam tear	PSTC-1
	Adhesion to Steel, 20 minute dwell	10 lbs/in width minimum	PSTC-1
	Static Shear @ 72°F 1 x 1 x 500 grams	1000 hours minimum	PSTC-7
	Static Shear @ 72°F 1 x 1 x 1000 grams	200 hours minimum	PSTC-7
	Shelf Life	1 year stored at room temperature	

PHYSICAL PROPERTIES	P8100 TAPE (MEDIUM DENSITY)	TEST METHOD	UNIT OF MEASURE	RESULT
Density (PCF)		ASTM D1056	PCF	4-8
			kg/cm3	.064-.128
ASTM-D-1056-67 Grade #		--	--	SCE 42
ASTM-D-1056 07		--	--	2C2
Service Temperature		--	F	-40F to +250F
Water Absorption (Max)		ASTM D1056	%	5
Tensile Strength (Min)		ASTM D412 (DIE A)	PSI	75
			kPa	517
Elongation (Min)		ASTM D412 (DIE A)	%	150
Compression Deflection 25%		ASTM D1056	psi	5 - 9
Compression Set (Max)		ASTM D1056	%	25
Flammability (UL 94 HF1, FMVSS302)		UL E208679	Pass/Fail	Pass
UL 50, UL 50E, UL 157, UL 508		UL JMLU2, MH10200	Pass/Fail	Pass
Durometer		ASTM D1056	Shore 00	30-50



P8100 (SC 42-UL) Neoprene / EPDM / SBR Closed Cell Foam Tape

*For temperature resistance lower and or higher than the above figures, please contact customer service.
Under certain conditions, values greater than -40/+250 are possible.

Application Notes

Ensure bonding surfaces are well unified, clean, dry and free of dirt and oils. Apply firm and even pressure to improve adhesive-to-surface contact. Allow proper temperature and time to enhance bond strength as adhesive flows onto the surface.

IN NO EVENT WILL PRES-ON OR ANY OF ITS AFFILIATES BE LIABLE FOR ANY DIRECT OR INDIRECT DAMAGES, CLAIMS, OR LOSSES WHATSOEVER (INCLUDING, BUT NOT LIMITED TO, INCIDENTAL DAMAGES, CONSEQUENTIAL DAMAGES, LOST PROFITS AND/OR LOST OPPORTUNITIES) RESULTING FROM OR RELATED TO THIS PRODUCT OR THE USE, MISUSE, PURCHASE, OR SALE OF THIS PRODUCT, WHETHER BASED ON WARRANTY, CONTRACT, TORT, OR ANY OTHER LEGAL THEORY, WHETHER OR NOT FORESEEABLE, AND WHETHER OR NOT ADVISED OF THE POSSIBILITY OF SUCH DAMAGES. Any specifications, instructions, or other information provided by Pres-On in connection with this product are provided for informational purposes only and shall not be deemed to impose any representations, warranties, covenants or other obligations upon Pres-On or any of its affiliates.

MARK	TYPE	FACE SIZE (IN)	NECK SIZE (IN)	MIN FLOW (CFM)	MAX FLOW (CFM)	MAX PD (IN)	MAX NC LEVEL	BASED ON MANUFACTURER MOD	COMMENTS
3W-01								RAPID ENGINEERING 4044	3-WAY DISCHARGE HEAD
3W-02								RAPID ENGINEERING 4054	3-WAY DISCHARGE HEAD

Two sizes are required.

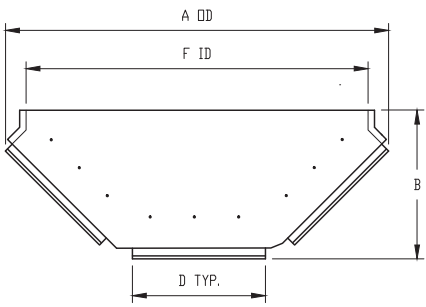

- (1) ALL DIMENSIONS AND WEIGHTS ARE SUBJECT TO CHANGE WITHOUT NOTICE AND SHOULD NOT BE USED FOR CONSTRUCTION UNLESS CERTIFIED.
- (2) THE DISCHARGE HEAD HAS MANUALLY ADJUSTABLE HORIZONTAL BLADES. (VERTICAL BLADES OPTIONAL.)
- (3) DISCHARGE HEAD MUST BE FIELD SUPPORTED BY OTHERS

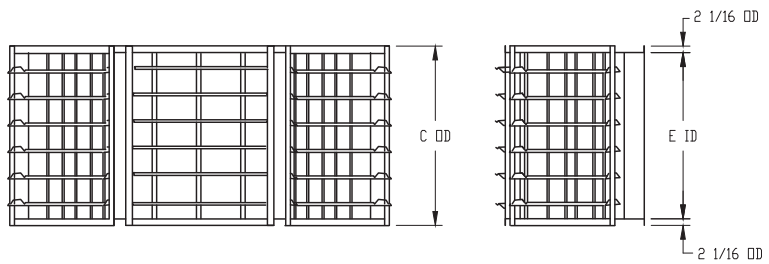

IMPORTANT NOTES:

- All dimensions are in inches.
- All weights are in pounds.
- All dimensions and weights are subject to change without notice.
- The discharge head has manually adjustable horizontal blades (vertical blades are optional).
- Discharge head requires field support and mounting by installer.

Model	Dimensions						Weight
	A	B	C	D	E	F	
4024	44	25	24.4	14	20.3	29.3	73
4036	62	30	29.4	22	25.3	47.3	110
4040	65	31	37.4	23	33.3	50.3	128
4044	71	32	40.4	26	36.3	56.3	167
4049	78	34	43.4	28	39.3	63.3	208
4054	82	37	47.4	32	43.3	72.3	242
4060	96	40	52.4	36	48.3	81.3	272
4066	106	43	54.4	40	50.3	91.3	300
4073	114	45	54.4	40	50.3	99.3	324
4080	131	48	64.4	50	60.3	116.3	465
4089	131	48	64.4	50	60.3	116.3	465

HORIZONTAL AIR HANDLER - SIDE DISCHARGE (SB)

MODEL	A	B	C	D	E	F	VEL	WT(lbs)
54	58	29	79 3/8	20	75 1/4	43 1/4	1832	242

THIS SHEET IS FOR GENERAL INFORMATION PURPOSES ONLY. INFORMATION CAN CHANGE WITHOUT NOTICE AND SHOULD THEREFORE NOT BE USED FOR CONSTRUCTION OR INSTALLATION. ALL PRODUCTS MUST BE SET-UP, ASSEMBLED, INSTALLED AND USED IN ACCORDANCE WITH ALL APPLICABLE INSTRUCTIONS, THE PROVIDED INSTRUCTION MANUAL AS WELL AS REQUIREMENTS OF GOVERNMENTAL AUTHORITIES. THE INFORMATION ON THIS SHEET IS PROPRIETARY AND IS THE PROPERTY OF RAPID ENGINEERING LLC. ©RAPID ENGINEERING LLC

REV.	ECD#	DATE	CK BY	RAPID ENGINEERING LLC				
D	010012	01/08/02	MAP	4000 AM, MUA, & AR 120° Discharge Head Data				
C	-	09/10/01	MAP					
B	-	03/18/94	KAB					
Job: -				SCALE: NON-STD	DRAWN BY: KAB	DATE: 7/13/92	REV: DWG NO.	
Date: - Tag#: -				FILE LOCATION: HTR-SUB	PLDT RATIO: NONE	CK BY: KJI	WD# - B	30000643

APPROVAL DRAWINGS

Please sign & return SPECIFIED AIR
 one copy to: 1100 SEVEN MILE RD. N.W.
 COMSTOCK PARK, MI 49321

This DWG & _____ additional DWG's attached here to.
 Approved by: _____

Company Name _____ Date _____

- NOTE: (1) CONTRACTOR/INSTALLER MUST MAKE APPROPRIATE ALLOWANCES FOR DUCT CONNECTIONS.
- (2) ALL DIMENSIONS AND WEIGHTS ARE SUBJECT TO CHANGE WITHOUT NOTICE AND SHOULD NOT BE USED FOR CONSTRUCTION UNLESS CERTIFIED.

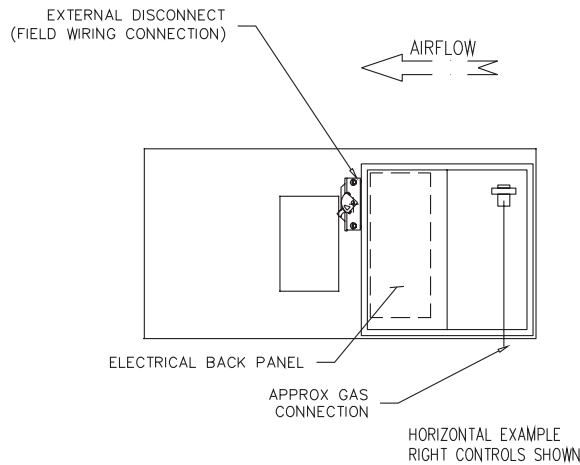

Air Handlers for this project are to be equipped with opposite (LEFT HAND) utility connections

THIS SHEET IS FOR GENERAL INFORMATION PURPOSES ONLY. INFORMATION CAN CHANGE WITHOUT NOTICE AND SHOULD THEREFORE NOT BE USED FOR CONSTRUCTION OR INSTALLATION. ALL PRODUCTS MUST BE SET-UP, ASSEMBLED, INSTALLED AND USED IN ACCORDANCE WITH ALL APPLICABLE INSTRUCTIONS, THE PROVIDED INSTRUCTION MANUAL AS WELL AS REQUIREMENTS OF GOVERNMENTAL AUTHORITIES. THE INFORMATION ON THIS SHEET IS PROPRIETARY AND IS THE PROPERTY OF SPECIFIED AIR. © SPECIFIED AIR

REV.	ECO#	DATE	CK BY	SPECIFIED AIR				AT
-	-	-	-	DESC: TYPICAL GAS AND ELECTRICAL CONNECTIONS				
-	-	-	-	SCALE 1/4" = 1'	DRAWN BY: KTD	DATE: 10/7/22	REV.	DWG NO.
-	-	-	-	FILE LOCATION: HTR-SUB	PLOT RATIO: 1:48	CK BY: -	WO# -	40612399

Job: -
 Date: 10/7/22 Tag#: -

Fan for HVU-R02, R03,
R04, R05 and R06

Fan for HVU-R01 and R07

RAPID ENGINEERING

460 VOLTS, 3 PHASE, 60 HERTZ

SUGGESTED FEEDER
SHORT CIRCUIT
PROTECTIVE DEVICE

MOTOR HORSE POWER	1	1.5	2	3	5	7.5	10	15	20	25	30	40	50	60	75	100	125
*FLA (MOTOR) NFPA-70	2.1	3	3.4	4.8	7.6	11	14	21	27	34	40	52	65	77	96	124	156
DUAL ELEMENT TIME DELAY FUSE	4 AMP	5 AMP	7 AMP	8 AMP	15 AMP	20 AMP	25 AMP	35 AMP	45 AMP	60 AMP	70 AMP	90 AMP	110 AMP	150 AMP	175 AMP	225 AMP	300 AMP
INVERSE TIME CIRCUIT BREAKER	8 AMP	8 AMP	10 AMP	15 AMP	20 AMP	25 AMP	35 AMP	50 AMP	60 AMP	80 AMP	90 AMP	125 AMP	150 AMP	175 AMP	225 AMP	300 AMP	400 AMP

* FULL LOAD AMPS TAKEN FROM THE NATIONAL ELECTRICAL CODE, ARTICLE 430, TABLE 430:247-250.
CONSULT THE NATIONAL ELECTRIC CODE (NFPA 70) FOR CONDUIT AND WIRE SIZING.

THIS SHEET IS FOR GENERAL INFORMATION PURPOSES ONLY. INFORMATION CAN CHANGE WITHOUT NOTICE AND SHOULD THEREFORE NOT BE USED FOR CONSTRUCTION OR INSTALLATION. ALL PRODUCTS MUST BE SET-UP, ASSEMBLED, INSTALLED AND USED IN ACCORDANCE WITH ALL APPLICABLE INSTRUCTIONS, THE PROVIDED INSTRUCTION MANUAL AS WELL AS REQUIREMENTS OF GOVERNMENTAL AUTHORITIES. THE INFORMATION ON THIS SHEET IS PROPRIETARY AND IS THE PROPERTY OF RAPID ENGINEERING LLC. ©RAPID ENGINEERING LLC

Job: -
Date: - Tag#: -

REV.	ECO#	DATE	CK BY	RAPID ENGINEERING LLC			
D	-	04/07/14	MP	460 VOLTS, 3 PHASE, 60 HERTZ (DESCRIPTIVE CHART)			
C	-	11/12/12	MP				
B	-	3-22-99	KP	SCALE 12" = 1'	DRAWN BY: KP	DATE: 3-25-98	REV. DWG NO.
FILE LOCATION: HTR-SUB			PLOT RATIO: 1:1		CK BY: DAP	WO# -	D 40001000

R/RS SERIES

Balanced Valve Design

The R & RS series' double diaphragm balanced valve design makes it possible to maintain steady outlet pressure control with widely varying inlet pressures. The regulator is physically small yet has exceptional capacity characteristics. R & RS series regulators are intended for use with both main burner and pilot load applications. They are ideally suited for use with infrared heaters and pilot lines on large industrial heaters and boilers.



R400

Specifications

- Pipe Sizes** 3/8" to 1" threaded connections with NPT or ISO7-1 threads.
- Housing Material** R400(S), R500(S), R600(S): aluminum.
- Mounting** Suitable for multi-positional mounting. If ball check vent limiting device is installed, mount in an upright position only.
NOTE: All Maxitrol gas pressure regulators should be installed and operated in accordance with Maxitrol Safety Warning Instructions (see GPR_MI_EN.ES or GPR_CSA_MI_EN.FR).
- Certifications** R400(S), R500(S), R600(S): ANSI Z21.18/CSA 6.3 Gas Appliance Pressure Regulators.
- Gas Types** Suitable for natural, manufactured, mixed gases, liquefied petroleum gases, and LP gas-air mixtures.
- Maximum Inlet Pressure** CSA Certified: R400(S), R500(S), R600(S): 1/2 psi (3.4 kPa)
Maxitrol Tested: R400, R500, R600: 1 psi (6.9 kPa);
R400S, R500S, R600S: 5 psi (34.5 kPa)
- Emergency Exposure Limits** R400, R500, R600: 2 psi (13.8 kPa)
R400S, R500S, R600S: 12.5 psi (86.2)
- Ambient Temperature Ranges** R400(S), R500(S), R600(S): -40° to 205°F (-40° to 96°C)
- Zero Governor Models** Please refer to pages 32-37 for RZ model information.
- Minimum Regulation** Suitable for pilot flow applications. (P) (Circle P) (0.15 CFH NG), None (1.5 CFH NG).



Capacities and Pressure Drop

Capacities expressed in CFH (m³/h) @ 0.64 sp gr gas

Model	Pipe Size	Pressure Drop - inches w.c. (kPa)										
		0.2 (0.05)	0.4 (0.10)	0.6 (0.15)	0.8 (0.20)	1.0 (0.25)	1.5 (0.37)	2.0 (0.50)	2.5 (0.62)	3.0 (0.75)	3.5 (0.87)	4.0 (1.0)
R400(S)	3/8" x 3/8"	77 (2.3)	110 (3.1)	134 (3.8)	155 (4.3)	174 (4.9)	212 (5.9)	245 (6.9)	274 (7.7)	---	---	---
	1/2" x 1/2"	86 (2.4)	121 (3.4)	148 (4.1)	172 (4.82)	192 (5.4)	235 (6.6)	271 (7.6)	303 (8.5)	---	---	---
R500(S)	1/2" x 1/2"	163 (4.6)	231 (6.5)	283 (7.9)	327 (9.2)	366 (10.3)	447 (12.5)	516 (14.6)	577 (16.2)	635 (17.9)	685 (19.2)	730 (20.44)
	3/4" x 3/4"	196 (5.5)	277 (7.8)	340 (9.5)	392 (11.0)	438 (12.3)	537 (15.0)	620 (17.4)	693 (19.4)	760 (21.3)	820 (23.0)	876 (24.53)
R600(S)	3/4" x 3/4"	298 (8.3)	421 (11.8)	516 (14.5)	595 (16.7)	666 (18.7)	816 (22.9)	942 (26.4)	1054 (29.5)	1150 (32.2)	1245 (34.86)	1335 (37.38)
	1" x 1"	330 (9.2)	468 (13.1)	572 (16.2)	661 (18.2)	739 (20.7)	906 (25.4)	1046 (29.3)	1169 (32.7)	1280 (35.8)	1380 (38.64)	1480 (41.44)

NOTE: CSA maximum capacities vary with spring range and pipe size. Please contact Maxitrol directly for CSA maximums. See pages 58-59 for Regulator Sizing Requirements and Examples.

Spring Selection Chart: inches w.c. (kPa)

Model	CSA Certified Springs			Other Springs Available					
R400(S)	3 to 6 (0.75 to 1.5) Plated	---	5 to 12 (1.25 to 3) Blue	1 to 3.5 (0.25 to 0.9) Brown	2 to 5 (0.5 to 1.25) Plated	3 to 8 (0.75 to 2) Pink	4 to 12 (1 to 3) Violet	10 to 22 (2.5 to 5.5) Red	---
R500(S)	3 to 6 (0.75 to 1.5) Plated	4 to 8 (1 to 2) Orange	5 to 12 (1.25 to 3) Blue	1 to 3.5 (0.25 to 0.9) Brown	2 to 5 (0.5 to 1.25) Plated	3 to 8 (0.75 to 2) Pink	4 to 12 (1 to 3) Violet	10 to 22 (2.5 to 5.5) Red	---
R600(S)	3 to 6 (0.75 to 1.5) Plated	4 to 8 (1 to 2) Orange	5 to 12 (1.25 to 3) Blue	1 to 3.5 (0.25 to 0.9) Brown	2 to 5 (0.5 to 1.25) Plated	3 to 8 (0.75 to 2) Pink	4 to 12 (1 to 3) Violet	10 to 22 (2.5 to 5.5) Red	15 to 30 (3.7 to 7.5) Yellow

NOTE: See pages 56-57 for complete Spring Selection Chart.

R/RS SERIES

Balanced Valve Design

Dimensions

Model	Pipe Size	Vent Connection	Swing Radius	Dimensions			
				A	B	C	D
R400(S)	3/8", 1/2"	1/8" NPT	2.4" (60 mm)	3.3" (83 mm)	2" (51 mm)	2" (51 mm)	0.9" (24 mm)
R500(S)	1/2", 3/4"	1/8" NPT	3.6" (90 mm)	4.7" (119 mm)	3.1" (79 mm)	3" (76 mm)	1.2" (30 mm)
R600(S)	3/4", 1"	1/8" NPT	4.3" (110 mm)	5.7" (145 mm)	3.9" (99 mm)	4" (103 mm)	1.5" (38 mm)

NOTE: Dimensions are maximums and to be used only as an aid in designing clearance for the valve. Actual production dimensions may vary somewhat from those shown.

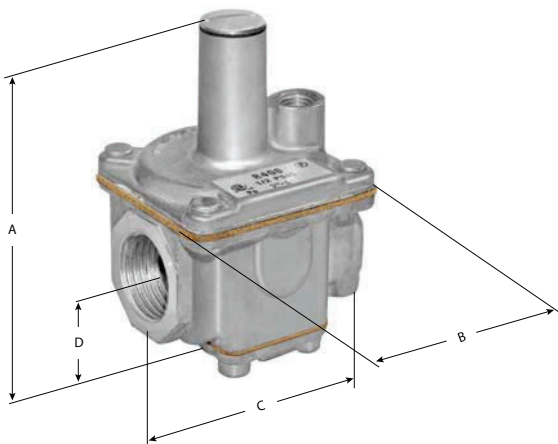

R400(S)

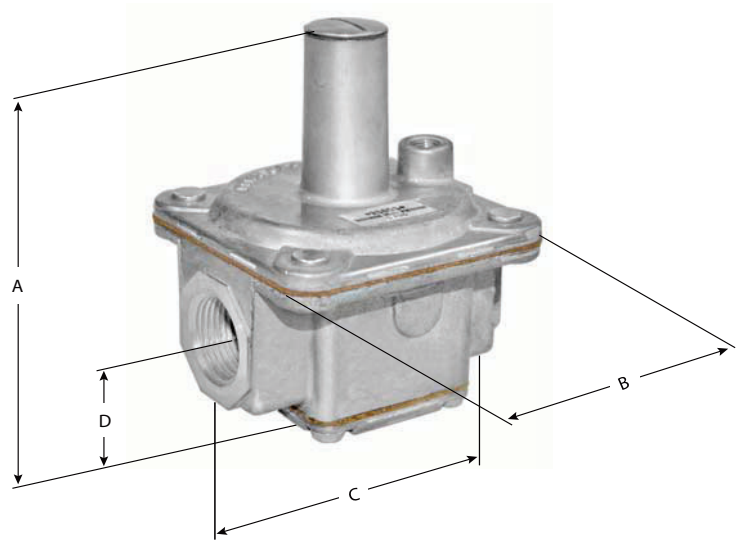

R500(S), R600(S)

ACCESSORIES

Vent Tube Connector

Threaded sleeve - two piece assembly where the nut is tightened inside male connector.

- **11A03:** connects 1/8" female pipe thread to 1/8" O.D. tubing.
- **11A04:** connects 1/8" female pipe thread to 1/4" O.D. tubing.

Threaded sleeve nut - for RV20V.

- **11A08:** 5/16-24 threaded sleeve nut for 1/8" O.D. tubing.

Compression fitting - where nut and sleeve are slipped over tubing and tightened into fitting body.

- **11A05-42:** connects 1/4" female pipe thread to 1/4" O.D. tubing.
- **11A05-61:** connects 1/8" female pipe thread to 1/8" O.D. tubing.
- **11A05-63:** connects 3/8" female pipe thread to 3/8" O.D. tubing.
- **11A05-64:** connects 1/2" female pipe thread to 3/8" O.D. tubing.

Vent Limiting Device: vLimiter®

Optional automatic vent limiting device - ball check permits unobstructed inhalation for fast regulator diaphragm response on opening cycle, but limits gas escape-ment to within ANSI standards should a diaphragm rupture.

NOTE: When using the vent limiting device, regulator must be mounted in a horizontal upright position.

- **12A04:** CSA certified for up to 1/2 psi (14" w.c.) inlet pressure. Use on RV48, RV52, RV53, RV61, R400(S), R500(S), R600(S) regulators. Color - brass. 1/8" NPT.
- **12A09:** CSA certified for 2 psi (LP) and 5 psi (natural) inlet pressure with 325-3 and 325-3L regulators; OPD48, OPD600. Color - green. 1/8" NPT.
- **12A34:** CSA certified for up to 1/2 psi (14" w.c.) inlet pressure with RV81. Color - brass. 3/8" NPT.
- **12A39:** CSA certified for 2 psi (LP) and 5 psi (natural) inlet pressure with 325-5 and 325-5L regulators; OPD210D. Color - brass. 3/8" NPT.
- **12A49:** CSA certified for 2 psi (LP) and 5 psi (natural) inlet pressure with 325-7A, 325-7AL, 325-9, and 325-9L regulators; OPD210E. Color - brass. 1/2" NPT.

Satisfies ANSI Standards for both Natural and LP gas.

NOTE: Vent limiters are not recommended for use in models RV91, RV111, RV131, and 210 Series.

Vent Limiting Orifice

- **12A06:** Orifice hole is on side of body, under head. Fixed orifice equally limits inhalation and escapement. Use on RV48, RV52, RV53, RV61, R400(S), R500(S), R600(S) regulators. Color- brown. 1/8" NPT.

Satisfies ANSI Standards for both Natural and LP gas.



ESP Horizontal Plenum AF

Standard & Piggyback

Arrangement 3, SWSI, Class I & II

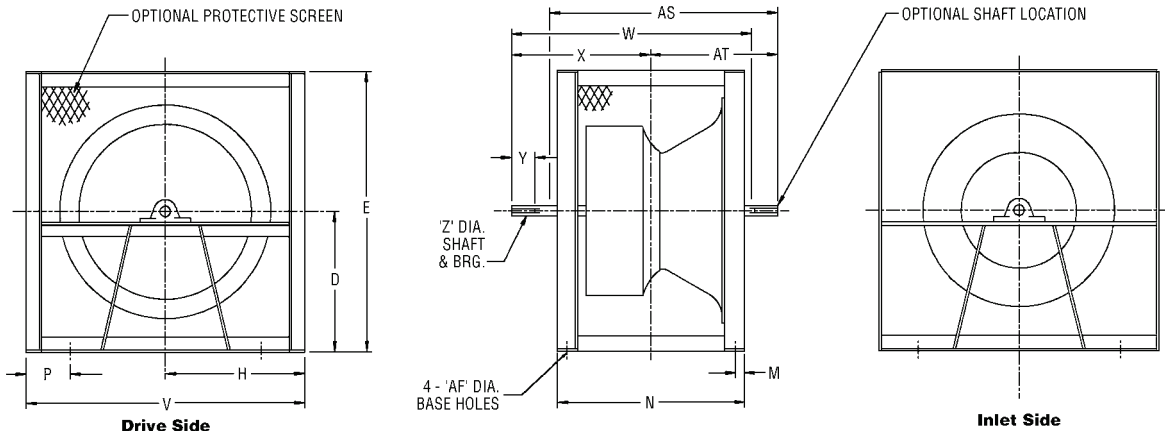

Notes:

1. CW & CCW rotation available. Rotation and motor position are determined from side opposite inlet.
2. Max. motor applies only to piggyback mounts.
3. Refers to all frame angles unless otherwise specified.
4. Dimensions should not be used for construction. Certified drawings are available upon request.

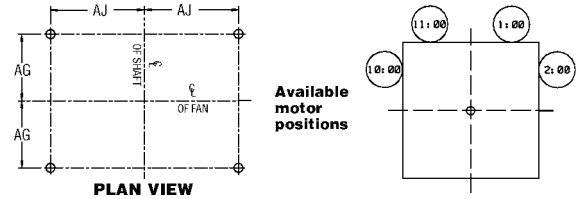

Dimensional Data

Size	D	E	H	V	N	Class I		Class II		Y	'Z' - Class I		'Z' - Class II		Class I		Class II		P	M	AF	AG	AJ	(3.) Angle	(2.) Max. Mtr.
						W	X	W	X		Shaft	Keyway	Shaft	Keyway	AS	AT	AS	AT							
						W	X	W	X		AS	AT	AS	AT											
182	14.50	28.00	13.00	26.00	18.50	27.00	15.75	27.50	16.06	3.50	1.188	0.25 x 0.13	1.688	0.38 x 0.19	28.13	16.88	28.25	16.88	3.38	0.88	0.56	8.38	9.63	1.50 x 2.00	215T
200	16.00	31.00	14.50	29.00	20.13	28.63	16.50	29.13	16.88	3.50	1.188	0.25 x 0.13	1.688	0.38 x 0.19	29.75	17.75	29.88	17.75	3.63	0.88	0.56	9.19	10.88	1.50 x 2.00	254T
222	18.00	35.25	16.25	32.50	21.63	30.63	17.75	31.13	18.13	4.00	1.188	0.25 x 0.13	1.688	0.38 x 0.19	31.75	19.00	31.88	19.00	5.13	0.88	0.56	9.94	11.13	2.00 x 2.00	254T
245	19.50	37.75	17.25	34.50	23.63	33.25	19.13	33.25	19.13	4.00	1.438	0.38 x 0.19	1.688	0.38 x 0.19	33.88	20.00	33.88	20.00	6.13	0.88	0.56	10.94	11.13	2.00 x 2.00	256T
270	21.50	41.25	18.75	37.50	25.63	35.25	20.19	35.25	20.19	4.00	1.688	0.38 x 0.19	1.688	0.38 x 0.19	36.00	21.00	36.00	21.00	5.63	0.88	0.56	11.94	13.13	2.00 x 2.00	256T
300	24.00	45.00	21.00	42.00	28.81	37.25	21.13	37.63	21.38	4.00	1.688	0.38 x 0.19	1.938	0.50 x 0.25	37.88	21.94	38.00	21.94	4.13	1.13	0.56	13.31	16.88	2.50 x 2.50	284T
330	26.50	49.50	23.00	46.00	31.38	39.88	22.38	40.25	22.63	4.00	1.688	0.38 x 0.19	1.938	0.50 x 0.25	40.38	23.25	40.50	23.25	4.13	1.13	0.56	14.56	18.88	2.50 x 2.50	286T
365	29.00	53.50	24.50	49.00	33.88	43.50	24.75	43.88	25.00	5.00	1.688	0.38 x 0.19	1.938	0.50 x 0.25	44.00	25.50	44.13	25.50	4.13	1.13	0.56	15.81	20.38	2.50 x 2.50	324T
402	32.00	60.00	27.00	54.00	38.06	48.00	27.00	48.63	27.38	5.00	1.938	0.50 x 0.25	2.188	0.50 x 0.25	48.88	28.13	49.13	28.13	4.63	1.38	0.56	17.69	22.38	3.00 x 3.00	326T
445	33.75	64.00	29.25	58.50	41.25	51.75	29.13	52.38	29.50	5.50	1.938	0.50 x 0.25	2.188	0.50 x 0.25	52.50	30.25	52.88	30.25	5.63	1.38	0.81	19.25	23.63	3.00 x 3.00	326T
490	37.50	70.00	31.50	63.00	45.00	56.00	31.38	56.75	31.88	5.50	2.188	0.50 x 0.25	2.438	0.63 x 0.31	56.63	32.13	56.75	32.13	5.63	1.38	0.81	21.13	25.88	3.00 x 3.00	326T
542	40.50	75.00	34.50	69.00	50.75	61.00	34.19	61.13	34.25	6.00	2.438	0.58 x 0.31	2.688	0.63 x 0.31	61.00	34.50	61.00	34.50	5.63	1.88	0.81	23.50	28.88	3.00 x 4.00	326T

Dimensions in inches.

<p>PENNBARRY™</p> <p>1401 North Plano Road, Richardson, TX 75081 Ph: 972.234.3202 Fax: 972.497.0468 www.PennBarry.com</p>	<h2 style="margin: 0;">Submittal Sheet</h2> <h3 style="margin: 0;">ESP Horizontal Plenum AF</h3> <h4 style="margin: 0;">Standard & Piggyback</h4> <h4 style="margin: 0;">Arrangement 3, SWSI, Class I & II</h4>
--	---

This drawing illustrates our understanding of order requirements. When approved, it represents details for fabrication, as such, PennBarry will not be responsible for revisions in the field or other changes after release for fabrication. Published and protected by PennBarry, Richardson, TX. All rights reserved. May not be reproduced partially or in full without permission from the publisher. No rights conveyed to manufacture partially or in full, use or sell either the method of construction represented or any invention in any way related thereto.

Brass Ball Valves

Two-Piece Body • Full Port • Blowout-Proof Stem • PTFE Seats
1/4"-2" 600 PSI/41.4 Bar Non-Shock Cold Working Pressure
2 1/2"-4" 400 PSI/27.6 Bar Non-Shock Cold Working Pressure

CSA CERTIFIED TO ASME B16.44 AND CR91-002 (THREADED 1/4"-4")
 • UL LISTED (THREADED 1/4"-4") • FM APPROVED (THREADED 1/4"-2")
 • CRN: OC19353.5XX*

Threaded

CSA (1/4" - 4"):

- CR91-002: 1/2 psig, 2 psig, and 5 psig (these are specific approved categories)
- ASME B13.44: 125 psig (maximum)
- Temperature is -4° F to 194° F

Threaded

FM (1/4" - 2"):

- 175wvp Threaded

UL, Gas and Oil (1/4" - 4"):

- YQNZ, Compressed Gas Shutoff Valves: 250 psi
- YRBX, Flammable Liquid Shutoff Valves: 250 psi
- YRPV, Gas Shutoff Valves: 250 psi
- YSDT, LP-Gas Shutoff Valves: 250 psi
- MHKZ, Manual Valves: 250 psi

*Please contact Technical Customer Service for the CRN Jurisdictions/Provinces list

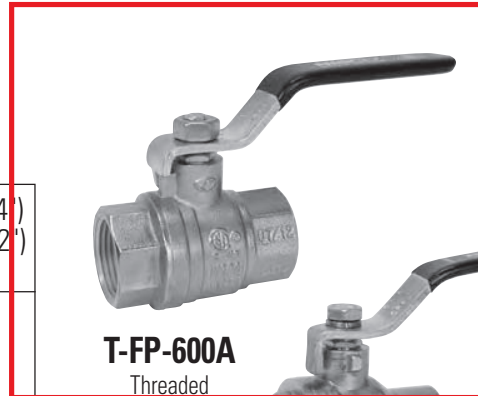

T-FP-600A
Threaded

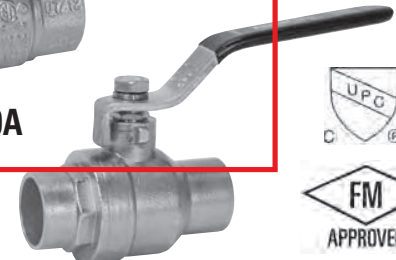

S-FP-600A
Solder



MATERIAL LIST

PART	SPECIFICATION
1. Body	Forged Brass ² CU > 57%
2. End Cap	Forged Brass ² CU > 57%
3. Ball Seat	PTFE
4. Ball	Chrome Plated Brass - C46500 (1/4"-1"), Stainless Steel 316 (1 1/4"-4")
5. Stem	Brass
6. O-Ring (Stem Seal)*	Fluorocarbon (FKM)
7. Stem Packing	PTFE
8. Packing Nut	Brass
9. Lever Handle ¹	Steel, Plated
10. Lock Washer*	Stainless Steel
11. Handle Nut ¹	Stainless Steel

Note: * Parts 6 and 10 are applicable of S-FP-600A only.

¹ Due to Standard Approvals, Lever Handles and Nuts are not interchangeable between Solder and Threaded.

² For Material Certification, contact NIBCO Technical Services.

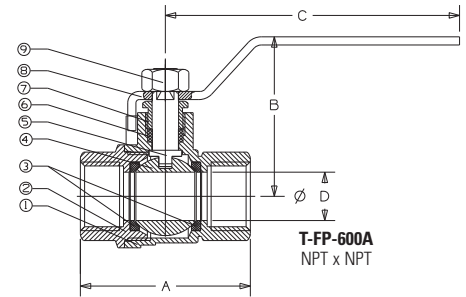

T-FP-600A
NPT x NPT

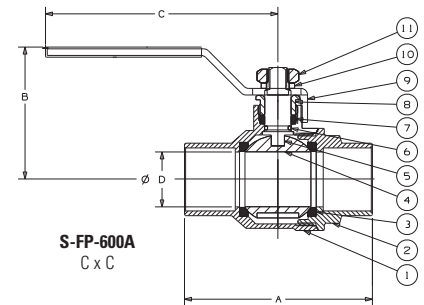

S-FP-600A
C x C

DIMENSIONS—WEIGHTS—QUANTITIES

Dimensions

Size	T-FP-600A		S-FP-600A		T-FP-600A		S-FP-600A		Port D	T-FP-600A		S-FP-600A		T-FP-600A Ctn. Qty.	S-FP-600N Ctn. Qty.
	A	A	B	B	C	C	Lbs.	Kg.		Lbs.	Kg.				
In. mm.	In. mm.	In. mm.	In. mm.	In. mm.	In. mm.	In. mm.	In. mm.	In. mm.	In. mm.	Lbs.	Kg.	Lbs.	Kg.		
1/4 8	1.76 45	— —	1.73 44	— —	3.54 90	— —	3.54 90	— —	.39 10	.33 .15	— —	— —	— —	18	—
3/8 10	1.76 45	1.75 44	1.73 44	1.58 40	3.54 90	3.78 96	3.78 96	.39 10	.30 .14	.38 .17	.38 .17	.38 .17	.38 .17	18	18
1/2 15	2.05 52	2.01 51	1.92 49	1.78 45	3.54 90	3.78 96	3.78 96	.59 15	.44 .20	.40 .18	.40 .18	.40 .18	.40 .18	18	18
3/4 20	2.36 60	2.74 70	2.09 53	2.13 54	3.78 96	3.98 101	3.98 101	.75 19	.66 .30	.67 .30	.67 .30	.67 .30	.67 .30	12	12
1 25	2.76 70	3.35 85	2.56 65	2.52 64	4.53 115	4.41 112	4.41 112	.98 25	1.10 .50	1.12 .51	1.12 .51	1.12 .51	1.12 .51	6	6
1 1/4 32	3.31 84	3.78 96	2.95 75	2.65 67	4.53 115	5.04 128	5.04 128	1.26 32	1.57 .71	1.49 .67	1.49 .67	1.49 .67	1.49 .67	4	4
1 1/2 40	3.66 93	4.42 112	3.35 85	3.12 79	5.51 140	6.22 158	6.22 158	1.57 40	2.40 1.09	2.38 1.08	2.38 1.08	2.38 1.08	2.38 1.08	2	2
2 50	4.18 106	5.34 136	3.68 93	3.41 87	5.51 140	6.22 158	6.22 158	1.97 50	3.37 1.53	3.62 1.64	3.62 1.64	3.62 1.64	3.62 1.64	2	2
2 1/2 65	5.38 137	6.28 160	4.76 121	4.76 121	8.66 220	8.66 220	8.66 220	2.56 65	7.60 3.45	6.36 2.88	6.36 2.88	6.36 2.88	6.36 2.88	3	3
3 75	6.04 153	7.15 182	5.08 129	5.08 129	8.66 220	8.66 220	8.66 220	2.95 75	9.36 4.24	8.32 3.77	8.32 3.77	8.32 3.77	8.32 3.77	2	2
4 100	7.39 188	— —	5.87 149	— —	9.61 244	— —	— —	3.89 99	16.85 7.64	— —	— —	— —	— —	1	—

NOT FOR USE WITH POTABLE DRINKING WATER APPLICATIONS AFTER JANUARY 3, 2014.

WARNING: This product can expose you to chemicals including lead, which is known to the State of California to cause cancer and birth defects or other reproductive harm. For more information go to www.P65Warnings.ca.gov.

Brass Ball Valves

Two-Piece Body • Full Port • Blowout-Proof Stem • PTFE Seats
1/4"-2" 600 PSI/41.4 Bar Non-Shock Cold Working Pressure
2 1/2"-4" 400 PSI/27.6 Bar Non-Shock Cold Working Pressure

CSA CERTIFIED TO ASME B16.44 AND CR91-002 (THREADED 1/4"-4")
 • UL LISTED (THREADED 1/4"-4") • FM APPROVED (THREADED 1/4"-2")
 • CRN: OC19353.5XX*

Threaded

CSA (1/4" - 4"):

- CR91-002: 1/2 psig, 2 psig, and 5 psig (these are specific approved categories)
- ASME B13.44: 125 psig (maximum)
- Temperature is -4° F to 194° F

Threaded

FM (1/4" - 2"):

- 175wwp Threaded

UL, Gas and Oil (1/4" - 4"):

- YQNZ, Compressed Gas Shutoff Valves: 250 psi
- YRBX, Flammable Liquid Shutoff Valves: 250 psi
- YRPV, Gas Shutoff Valves: 250 psi
- YSDT, LP-Gas Shutoff Valves: 250 psi
- MHKZ, Manual Valves: 250 psi

*Please contact Technical Customer Service for the CRN Jurisdictions/Provinces list

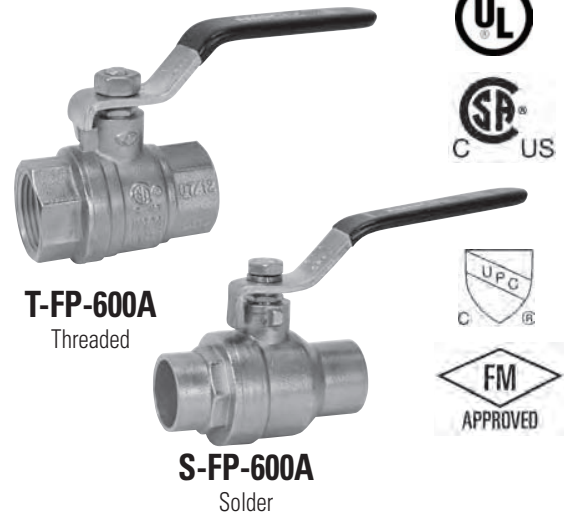

MATERIAL LIST

PART	SPECIFICATION
1. Body	Forged Brass ² CU > 57%
2. End Cap	Forged Brass ² CU > 57%
3. Ball Seat	PTFE
4. Ball	Chrome Plated Brass - C46500 (1/4"-1"), Stainless Steel 316 (1 1/4"-4")
5. Stem	Brass
6. O-Ring (Stem Seal)*	Fluorocarbon (FKM)
7. Stem Packing	PTFE
8. Packing Nut	Brass
9. Lever Handle ¹	Steel, Plated
10. Lock Washer*	Stainless Steel
11. Handle Nut ¹	Stainless Steel

Note: * Parts 6 and 10 are applicable of S-FP-600A only.

¹ Due to Standard Approvals, Lever Handles and Nuts are not interchangeable between Solder and Threaded.

² For Material Certification, contact NIBCO Technical Services.

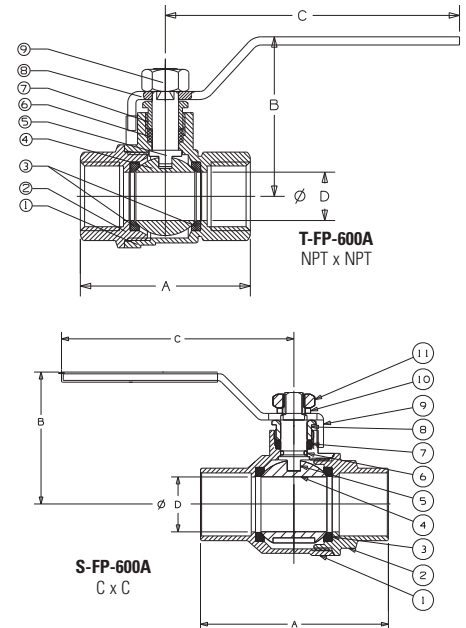

DIMENSIONS—WEIGHTS—QUANTITIES

Size	Dimensions												Port		T-FP-600A		S-FP-600A		T-FP-600A		S-FP-600A	
	T-FP-600A		S-FP-600A		T-FP-600A		S-FP-600A		T-FP-600A		S-FP-600A		T-FP-600A		S-FP-600A		T-FP-600A		S-FP-600A			
	A	A	B	B	C	C	D	D	Lbs.	Kg.	Lbs.	Kg.	Ctn.	Qty.	Ctn.	Qty.	Ctn.	Qty.	Ctn.	Qty.		
1/4	8	1.76	45	—	—	1.73	44	—	—	3.54	90	—	—	.39	10	.33	.15	—	—	18	—	
3/8	10	1.76	45	1.75	44	1.73	44	1.58	40	3.54	90	3.78	96	.39	10	.30	.14	.38	.17	18	18	
1/2	15	2.05	52	2.01	51	1.92	49	1.78	45	3.54	90	3.78	96	.59	15	.44	.20	.40	.18	18	18	
3/4	20	2.36	60	2.74	70	2.09	53	2.13	54	3.78	96	3.98	101	.75	19	.66	.30	.67	.30	12	12	
1	25	2.76	70	3.35	85	2.56	65	2.52	64	4.53	115	4.41	112	.98	25	1.10	.50	1.12	.51	6	6	
1 1/4	32	3.31	84	3.78	96	2.95	75	2.65	67	4.53	115	5.04	128	1.26	32	1.57	.71	1.49	.67	4	4	
1 1/2	40	3.66	93	4.42	112	3.35	85	3.12	79	5.51	140	6.22	158	1.57	40	2.40	1.09	2.38	1.08	2	2	
2	50	4.18	106	5.34	136	3.68	93	3.41	87	5.51	140	6.22	158	1.97	50	3.37	1.53	3.62	1.64	2	2	
2 1/2	65	5.38	137	6.28	160	4.76	121	4.76	121	8.66	220	8.66	220	2.56	65	7.60	3.45	6.36	2.88	3	3	
3	75	6.04	153	7.15	182	5.08	129	5.08	129	8.66	220	8.66	220	2.95	75	9.36	4.24	8.32	3.77	2	2	
4	100	7.39	188	—	—	5.87	149	—	—	9.61	244	—	—	3.89	99	16.85	7.64	—	—	1	—	

NOT FOR USE WITH POTABLE DRINKING WATER APPLICATIONS AFTER JANUARY 3, 2014.

WARNING: This product can expose you to chemicals including lead, which is known to the State of California to cause cancer and birth defects or other reproductive harm. For more information go to www.P65Warnings.ca.gov.

For Atmospheric, Infrared, and Direct Fired Burners

TABLE OF CONTENTS

Description/Specifications.....	1
Introduction	2
Direct Fired Applications (Negative Pressure)	2
Direct Fired Applications (Positive Pressure)	2
Indirect Fired Applications	3
'H' Suffix M/MR Valves	3
Applications Table	4
Dimensions	5
Capacities	6
Typical Gas Trains	7
Typical Installations	7
Model Designations	7

DESCRIPTION

Models:

M	M411, M411H, M511, M511H, M611, M611H, M420, M420H, M520, M520H, M620, M620H, M451, M551, and M651.
MR	MR212D, MR212E, MR212G, MR212J (Flanged), MR251D, MR251E, MR251G, MR410, MR410-1, MR410H, MR410H-1, MR510, MR510-1, MR510H, MR510H-1, MR610, MR610-1, MR610H, and MR610H-1.

- Absolutely **NO EXTERNAL MECHANICAL ACTIVATION** required.
- MR Valve (only) performs dual function of modulation and pressure regulation.
- Provides infinite, continuous flame adjustment.
- May be factory installed or added in the field.
- Capacities to 30,000 CFH.
- Available in a wide range of body styles and pipe sizes.
- Designed for use with the Maxitrol Selectra® series of modulation systems - or SC11 Signal Conditioners convert computer/PLC controller signals if standard Maxitrol companion controls are not specified.

Whether your needs are problem-free stabilized area heating, elevated heating, consistent higher baking/drying temperatures or other process applications, maintaining consistent temperatures is no longer a problem.

The unique Modulator or Modulator/Regulator valve, the heart of the Selectra® Electronic Gas Flame Modulating System, provides precise, non-fluctuating, instantaneous temperature control without requiring a motor or mechanically driven butterfly valve.



Figure 1 : MR212

SPECIFICATIONS

Gases:

Natural, Manufactured, Mixed, Liquefied Petroleum and Liquefied Petroleum Gas Air Mixtures. H, H-1 models for use with Liquefied Petroleum and other applications.

Certifications:

M611, MR212D, E, & G with Series 14: CSA listed to certify compliance with nationally published safety, construction, and performance standards.

M411, M420, M420H, M451, M511, M520, M520H, M611, M620, M620H, MR212D, E, G, & J with AD1094 controls: CSA listed to certify compliance with nationally published safety, construction, and performance standards.

MR410, MR410H-1, MR510, MR510H-1, MR610, and MR610H-1: CSA certified to Z21.18 and CSA 6.3-M82.

M511, M611, MR212D, E, & G: UL recognized for compliance to nationally published safety, construction, and performance standards in the U.S. and Canada.

Vent:

Models M411, M511, M611, M420, M520, M620, M420H, M520H, M620H, MR410(H)(-1), MR510(H)(-1), MR610(H)(-1), M551, M651: Vertical vent outlet 1/8" NPT - 12A06 installed.

Models MR212 and MR251: Two vents located in upper housing, both equipped with vent limiting means.

Ambient Limits:

Operating -40° to 125°F (-40° to 50°C)
 Non-operating -50° to 185°F (-45° to 85°C)

Mounting:

Must be mounted in upright position in horizontal pipe run, downstream of all other controls except high pressure cut-off switch if used (see Typical Installations, page 8).

INTRODUCTION

To evaluate which valve will satisfy your needs, it is necessary to determine the application. The first, and most basic breakdown, is direct versus indirect fired appliances.

Direct fired units do not have a heat exchanger and all products of combustion generated by the gas burning device are released directly into the airstream being heated. They are commonly used in space heating or make-up air applications, process drying, and baking ovens.

Direct fired burners have raw gas injected into the burner and the burner relies entirely on the air being pulled across the burner for combustion air. It may take advantage of the mixing effects of the blower by using a **pull through** system which locates the burner on the suction side of the blower. This means the air being pulled across the burner is at a negative pressure (usually not greater than -1.5" w.c.). Other direct fired applications may use a **push through** system, which locates the burner downstream from the blower. This means the air being pushed across the burner is at a positive pressure (usually not greater than 3" w.c.).

Direct fired burners can be of extremely high turn down ratios, in some instances, 30:1. The high turn down ratio allows the minimum temperature rise to be low enough that the unit does not have to be cycled on and off to maintain temperature.

Indirect fired appliances use a heat exchanger and all products of combustion generated by the gas burning device are vented outdoors. They are usually supplied with an atmospheric burner or a power burner.

With an atmospheric burner, the air being supplied to the burner is at atmospheric pressure. They have limited turndown ratios (maximum input: minimum input) of usually 3:1 or 4:1. Due to the limited turndown ratio, the minimum temperature rise cannot be held low enough, and as a result, the main gas valve must usually be cycled to maintain temperature.

A power burner is a burner in which either the gas, air, or both are supplied at pressures exceeding line pressure for gas and atmospheric pressure for air. Maintaining the proper gas-air mixture for modulation usually requires pressure control of both the air and gas. Burners of this type are usually not capable of modulation with the Maxitrol Selectra® system. (See Exa Star modulating valves or ratio (zero) regulators for these applications.)

DIRECT FIRED

Valves designed for direct fired applications (negative pressure/pull through) M411, M511, M611, MR212D, MR212E, MR212G, and MR212J.

These valves are designed exclusively for negative pressure (pull through) applications. They use a counter spring to keep the valve in the closed position despite the downward pull of negative pressure. M411, M511, and M611 valves are set for applications up to 1.5" w.c. and are not adjustable. MR212 valves are factory set for applications up to -1.5" w.c. and are field adjustable for up to -3.5" w.c.

With the main valve closed, an adjustable bypass provides a minimum firing rate to the burner whenever the safety shut-off valve(s) is open. This is low fire to the heater. Since the pressure regulator maintains a constant supply pressure, the minimum firing rate is also held constant. The MR212's regulator is an integral component while a separate upstream pressure regulator is required for the M411, M511, and M611.

As voltage is applied to the control's solenoid, a magnetic force is applied to the plunger. The plunger in turn pushes down on the main diaphragm of the M411, M511, and M611 valves or allows pressure to develop in the upper chamber of the MR212 valve. These forces on the main diaphragm are very similar to the spring loading of a gas pressure regulator. When the force is sufficient to overcome the counter spring, the main valve will open and gas will flow through the main valve in addition to flowing through the bypass. With sufficient voltage, the main valve (modulator valve for the MR212) will fully open and the pressure regulator will limit the burner pressure to the desired amount, thus establishing a controlled maximum high fire condition.

We now have two extremes. The first is low fire with no force on the plunger and flow through the bypass only. The second is high fire with sufficient force on the plunger to fully open the valve (modulator valve for the MR212), with the gas pressure regulator controlling the maximum firing pressure. Force on the plunger between these extremes results in modulated gas flow. The voltage versus outlet pressure curve, throughout the modulating range, is fairly linear.

There are also applications where it is desirable to have two separate high fire burner settings. Typical applications would be a two speed fan operation or LP natural gas change over. This is accomplished by adding an adjustable resistance to the circuit, thereby limiting voltage to the valve. Changing from one setting to another is done by connecting a single pole single throw switch (customer supplied) that when in the open position allows the outlet pressure to be adjusted up to 2" w.c. below normal maximum high fire. Negative pressure valves designed for dual pressure settings are designated with a "- 2" suffix (example: MR212D-2). Field conversion kits (KT/10542) to modify single pressure valves are also available.

The working voltage to operate the modulating controls can be supplied by the A1014, A1024, A1044, A1494 and AD1094 Amplifiers or the SC11 Signal Conditioner. (Refer to Bulletin SEL1444_CC_EN, SEL94_CC_EN, and SC11_MS_EN.)

Valves designed for direct fired applications (positive pressure/push through) MR212D-1, MR212E-1, MR212G-1, and MR212J-1.

The valve's operating principles are identical to the negative pressure MR212. The only difference is the valve has been designed to operate on positive pressure (push through) applications. Positive pressure valves designed for dual pressure settings are designated with a "- 3" suffix (example: MR212D-3).

INDIRECT FIRED

Valves designed to operate on indirect fired atmospheric burner applications M420, M520, M620.

These valves function in the same manner as the direct fired M valves. A pressure adjustment spring has been factory set to obtain an outlet pressure slightly above atmospheric pressure (0.1" w.c.) with the bypass closed and zero voltage being applied. The minimum flow rate is now adjusted through the bypass.

NOTE: Minimum outlet pressure is always above 0.2" w.c.
Maximum outlet pressure is 7.0" w.c.

The valves are driven by the A1094 and AD1094 Amplifiers or SC11 Signal Conditioners. (Refer to Bulletin SEL94_CC_EN & SC11_MS_EN.)

Valves designed to operate on indirect fired atmospheric burner applications M451, M551, M651, MR251D, MR251E, MR251G.

These valves function in the same manner as the direct fired M valves. Minimum input pressure is set using a minimum adjustment spring - the valves do not use a bypass.

They are used in applications where the minimum input pressure to burner is between 2.0" and 4.5" w.c. Maximum obtainable outlet pressure is 7.0" w.c. above minimum input pressure.

The valves are driven by the A1094 and AD1094 Amplifiers or SC11 Signal Conditioners. (Refer to Bulletin SEL94_CC_EN & SC11_MS_EN.)

MR410, MR510, and MR610

These valves use two springs in order to set the high and low fire settings. One spring (min.) surrounds the solenoid and is always in contact with the diaphragm assembly. The other spring (max.) is located above the plunger. With zero voltage applied, the minimum and maximum spring's down force, along with plunger weight, pushes down on the diaphragm thereby setting a regulated high fire. A separate pressure regulator is not required. As voltage is applied, the plunger pulls up sufficiently until all plunger weight and maximum spring force is removed. The pressure is now controlled with the minimum spring setting giving a regulated low fire condition. Force on the plunger between the extremes results in modulated gas flow. The voltage versus outlet pressure curve, throughout the modulating range, is not linear.

These valves are driven with the A1010 or A1011 Amplifier or SC11 Signal Conditioners. (Refer to Bulletin SEL2030_2131_CC_EN & SC11_MS_EN)

'H' SUFFIX MODELS

Valves designed with wider modulation span for use with LP (liquid propane gas) and other applications MR410H-1, MR510H-1, MR610H-1, M420H, M520H, M620H.

Can be configured for indirect fired atmospheric burner applications, as well as those with direct fired burners.

'H' models are designed for applications where outlet pressure is greater than 7" w.c. Minimum outlet pressure is factory set to 1.75" w.c. - remaining set pressure is obtained through bypass. The 'H' models are capable of a total modulation span of as much as 10" w.c. These models are not recommended for applications with a total modulation span of less than 7" w.c. - the sensitivity of outlet pressure change relative to voltage change could cause hunting to occur.

'H-1' models are designed for applications with a total modulation span greater than 7" w.c. Minimum outlet pressure range of 1" to 2.8" w.c.

NOTE: Temperatures shown in text are for Maxitrol's Selectra® systems. *Valves may be used for any temperature range or application the user's controller can handle.* When using valves for other ranges, a Maxitrol SC11 Signal Conditioner can be used in conjunction with the valve. (Refer to Bulletin SC11_MS_EN)

M/MR SERIES APPLICATIONS TABLE

Model Number	Max. Current Draw (amps)	Application	Function	CSA Tested* Inlet Pressure	Inlet Pressure Operating Limits	Upstream Pressure Regulator Required	Maximum Emergency Exposure	Output Control Means Standard Factory Setting (if applicable)	System Used With
M411 M511 M611	0.4 0.5 0.6	Direct Fired (Negative Pressure) Burners	Increase in voltage corresponds to increase in outlet pressure	1/2 psi (3.4 kPa)	Upstream pressure regulator setting	Yes	2.5 psi (17 kPa)	Low Fire: adjustable orifice bypass High Fire: upstream pressure regulator setting less pressure drop NOTE: 7" w.c. (1.7 kPa) max outlet pressure	Series 14, 24, 44, 94, SC11, DFM
M420 M420H M520 M520H M620 M620H	0.4 0.7 0.5 0.85 0.6 1.0	Atmospheric Burners H Models for higher outlet pressures (such as LP applications)	Increase in voltage corresponds to increase in outlet pressure	1/2 psi (3.4 kPa)	Upstream pressure regulator setting	Yes	2.5 psi (17 kPa)	Low Fire: adjustable orifice bypass High Fire: upstream pressure regulator setting less pressure drop NOTE: 7" w.c. (1.7 kPa) max outlet pressure NOTE: H models: 11" w.c. (2.7 kPa) max outlet pressure	Series 3, Series 94, SC11
M451 M551 M651	0.4 0.5 0.6	Atmospheric Burners - where higher outlet pressures are needed	Increase in voltage corresponds to increase in outlet pressure	1/2 psi (3.4 kPa)	Upstream pressure regulator setting	Yes	2.5 psi (17 kPa)	Low Fire: spring adjustment Std. Model: 1.2" - 2.5" w.c. (0.30-0.62 kPa) "-1" models: 2" - 4.5" w.c. (0.50-1.1 kPa) High Fire: upstream pressure regulator setting less pressure drop	Series 94, SC11
MR251D MR251E MR251G	0.4	Atmospheric Burners - where higher outlet pressures are needed	Increase in voltage corresponds to increase in outlet pressure	--	5 psi (34 kPa)	No	12.5 psi (86 kPa)	Low Fire: spring adjustment 2" - 4.5" w.c. (0.50-1.1 kPa) High Fire: maximum 7" w.c. (1.7 kPa) above minimum setting	Series 94, SC11
				CSA Rated** Inlet Pressure					
MR212D MR212E MR212G MR212J	0.4	Direct Fired (Negative Pressure) Burners	Increase in voltage corresponds to increase in outlet pressure	5 psi (34 kPa)	5 psi (34 kPa)	No	12.5 psi (86 kPa)	Low fire: adjustable orifice bypass High fire: spring adjustment High Fire Setting: Std. model: 2 - 5" w.c. (0.50-1.25 kPa) "-2" model: 2" - 5" w.c. (0.50-1.25 kPa) reduced to 0-3" w.c. (0-0.75 kPa)	Series 14, 24, 44, 94, SC11, DFM
MR410 MR410H-1 MR510 MR510H-1 MR610 MR610H-1	0.4 0.7 0.5 0.85 0.6 1.0	Atmospheric Burners H-1 models for higher outlet pressure (such as for LP applications)	Decrease in voltage corresponds to increase in outlet pressure	1/2 psi (3.4 kPa)	1 psi (7 kPa)	No	2.5 psi (17 kPa)	Low fire: spring adjustment High fire: spring adjustment Std. model: 3" - 5" w.c. (0.75-1.25 kPa) max-4" w.c. (1.0 kPa) "-1" model: min-1.5" w.c. (0.38 kPa) max-4" w.c. (1.0 kPa) "H-1" model: min outlet pressure = 1.75" w.c. (0.44 kPa) max outlet pressure = 11" w.c. (2.7 kPa) NOTE: "H-1" models: 7.5" to 12" w.c. (1.87 to 3 kPa) max outlet pressure	Series 20, 21, 30, 31

* Where no ANSI standard currently exists, Maxitrol Controls have been CSA tested for use as a component of Maxitrol Selectra® systems.

**CSA Rated Inlet Pressures are established by ANSI Z21.18, CSA 6.3, and CSA 6.5 standards where applicable.

DIMENSIONS



Figure 2: MR410, MR410H-1, M411, M420, M420H, M451

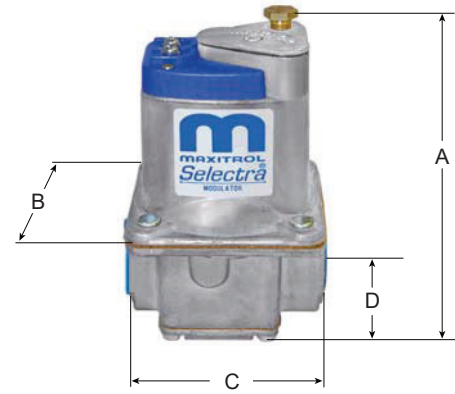

Figure 3: MR510, MR510H-1, M511, M520, M520H, M551



Figure 4: MR610, MR610H-1, M611, M620, M620H, M651

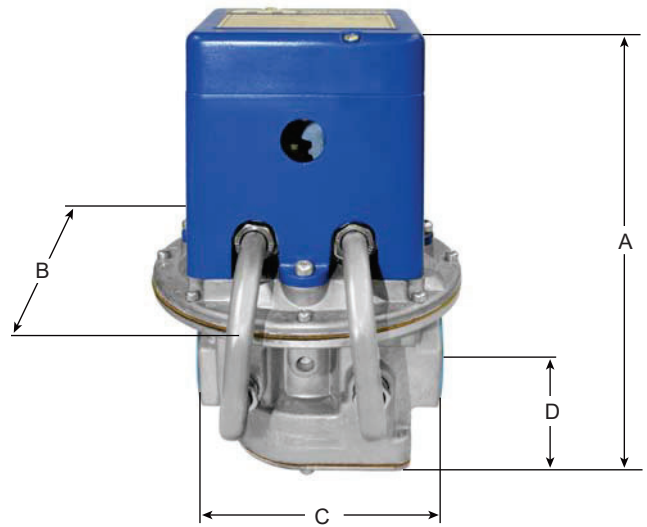

Figure 5: MR212, MR251 (Same as MR212 except single by-pass)

NOTE: Dimensions are to be used only as an aid in designing clearance for the valves. Actual production dimensions may vary somewhat from those shown.

Model Number	Swing Radius	Dimensions - Expressed in Inches (mm)			
		A	B	C	D
MR410, MR410H-1, M411, M420, M420H, M451	3.1 (79)	3.9 (100)	2 (51)	2.5 (54)	0.9 (24)
MR510, MR510H-1, M511, M520, M520H, M551	4.3 (109)	5.3 (135)	3.25 (83)	3.4 (86)	1.2 (30)
MR610, MR610H-1, M620, M620H, M651	5.7 (145)	7.1 (180)	3.9 (99)	4 (102)	1.5 (37)
M611	6.2 (158)	7.7 (196)	3.9 (99)	4 (102)	1.5 (37)
MR212D, MR251D	8.1 (206)	10.2 (259)	7 (178)	5.5 (140)	2.3 (59)
MR212E, MR251E	8.6 (218)	11.25 (286)	9.1 (232)	8 (203)	3 (76)
MR212G, MR251G	10.4 (264)	14.75 (375)	13.5 (343)	11.75 (298)	4.6 (118)
MR212J (Not Shown Above)	--	24 (610)	21.5 (546)	13.9 (352)	5.9 (149)

CAPACITIES

NOTE: For flows in excess of those shown below, consult with Maxitrol Company.

Model Number and Pipe Size		Flow Rate in CFH (m ³ /h)	1000 (28.3)	1500 (42.5)	2000 (56.5)	2500 (70.8)	3000 (85.0)	3500 (99.0)	5000 (142)	6000 (170)	7000 (198)	10000 (283)	11000 (311)	CSA Listed	Min. Flow Applies to MR212's only
MR212D* MR251D	1 x 1	Pressure Drop in inches w.c. (Pa)	1.9 (475)	2.9 (725)	4.9 (1225)	6.2** (1550)	--							2250	25-300 (0.71-8.5)
	1¼ x 1¼		1.7 (425)	2.3 (575)	3.1 (775)	4.8 (1200)	5.9** (1475)	--	--	--	--	--	--	2750	
	1½ x 1½		1.7 (425)	2.2 (550)	2.9 (725)	3.9 (975)	5.4 (1350)							3000	
MR212E*	1½ x 1½		--	--	1.9 (475)	2.4 (600)	2.9 (725)	3.5 (875)	6.0** (1500)	--	--	--	--	4750	25-300 (0.71-8.5)
MR251E	2 x 2		--	--	1.9 (475)	2.1 (525)	2.4 (600)	2.7 (675)	5.5 (1375)	6.0** (1500)	--	--	--	5250	
MR212G*	2½ x 2½		--	--	--	--	--	1.9 (475)	2.2 (550)	2.6 (650)	3.0 (750)	6.1 (1525)	--	10000	50-450 (1.4-12.7)
MR251G	3 x 3		--	--	--	--	--	--	2.1 (525)	2.3 (575)	2.6 (650)	4.6 (1150)	5.6 (1400)	11000	--

*U.L. recognized

**Pressure Drop figures derived from CSA Maximum Listed Capacities in far right column (not flow at column top).

Model Number and Pipe Size		Flow Rate in CFH (m ³ /h)	6000 (170)	8000 (227)	10000 (283)	12000 (340)	14000 (397)	16000 (397)	18000 (510)	20000 (566)	22000 (623)	24000 (680)	27000 (765)	30000 (850)	Min. Flow
MR212J	4 x 4	Pressure Drop in inches w.c. (Pa)	1.9 (475)	2.1 (525)	2.4 (600)	2.7 (675)	3.1 (775)	3.6 (900)	4.5 (1125)	5.4 (1350)	6.6 (1650)	7.8 (1950)	9.9 (2475)	12.4 (3100)	100-1000 (3.0-28.3)

DIRECT FIRED GAS TRAINS - TYPICAL

Modulator (M) or Modulator-Regulator (MR) Valve: Mount in upright position in horizontal run of pipe, downstream of other controls - a separate gas pressure regulator must be used with any modulator (M) valve.

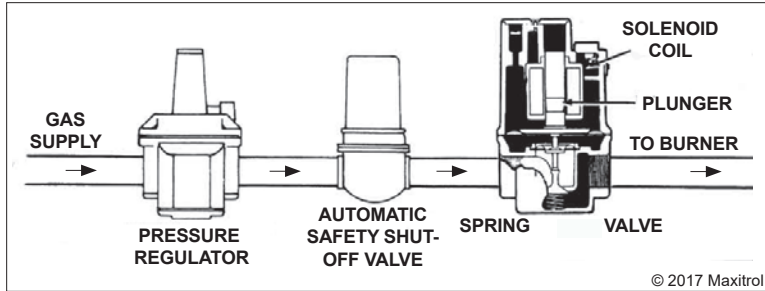

Figure 6 : M Valve-Regulator upstream of modulator valve

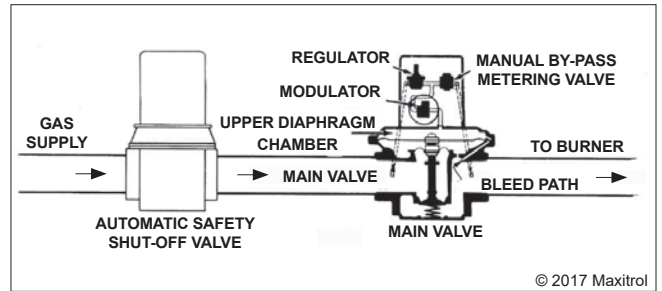

Figure 7 : MR212 Series Valve-Modulator/Regulator Valve

INDIRECT FIRED GAS TRAINS - TYPICAL

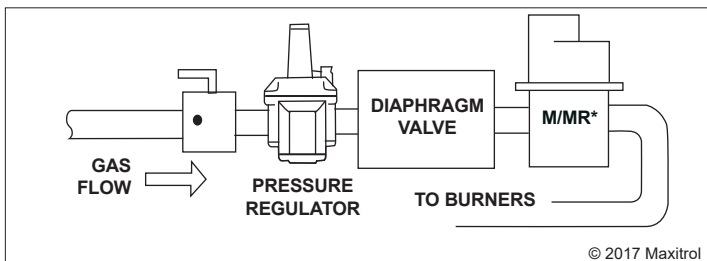

Figure 8 : If diaphragm type automatic gas valve is used with separate regulator, install MR valve downstream from diaphragm gas valve. Retain regulator in manifold and adjust 2 or 3 turns to compensate for pressure drop of MR valve.

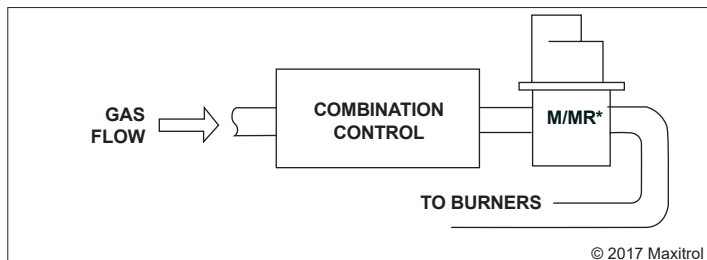

Figure 9 : If full combination control is used, install MR valve downstream. Adjust regulator in combination control 2 or 3 turns to compensate for pressure drop of MR valve.

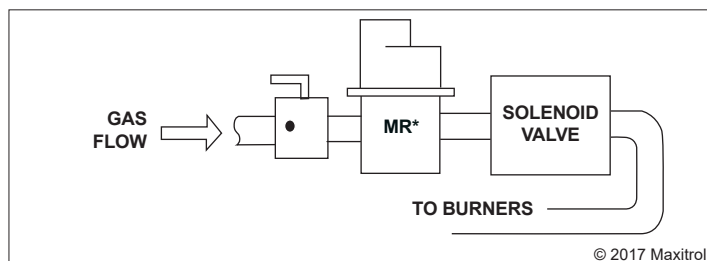

Figure 10 : If solenoid type automatic gas valve is used with separate regulator, replace regulator with the MR valve.

NOTE: MR Valve **must** be in upright position, in horizontal run of pipe only **with pilot gas supply upstream.**

*MR = MR410, MR510, & MR610 Series

MODEL DESIGNATIONS

Models having the letters B, H, M, R, or W, or a combination of these suffix letters, indicates the design modification described below:

B	Both sides fitted for low fire adjustment.
H	Capable of a total modulation span of as much as 10" w.c.
M	PL parallel thread conforms to ISO 7-1.
R	Right side outlet - low fire by-pass adjustment on right side. Available on models: M411, M511, M420, and M520.
W	Indicates covered wire terminal connections, same as M611. Available on models: M411, M511, M420, M520, M620, M451, M551, and M651.

NOTE: Models M411, M511, and M611 are available with 1/8" NPT connection for reading outlet pressure. Not available on "B" models connection is located on opposite side of by-pass adjustment (See Dimensions, page 5).

MAXITROL

MAXITROL

Gas Appliance Regulators R400, R500, R600 & R400S, R500S & R600S

MAXIMUM INLET PRESSURES:

CSA Certified

All R & RS models.....1/2 psi (34 mbar)

Maxitrol Tested

R400, R500, & R600.....1.0 psi (69 mbar)

R400S, R500S & R600S.....5.0 psi (345 mbar)

EMERGENCY EXPOSURE LIMITS:

R400, R500, R600.....2.0 psi (138 mbar)

R400S, R500S, & R600S.....12.5 psi (862 mbar)

AMBIENT TEMPERATURE LIMITS:

R400, R500, R600,

R400S, R500S, & R600S.....-40° to 205°F (-40° to 96° C)

VENTING.....1/8" NPT

GASES: Suitable for application in natural, manufactured, mixed gases, liquefied petroleum gases and LP gas-air mixture piping systems.

MOUNTING: Suitable for multiple-poise mounting-mount with flow direction as marked on bottom casting.



NOTE: All Maxitrol appliance regulators should be installed and operated in accordance with Maxitrol's "Safety Warning" Bulletin.

These regulators are not suitable for dead-end lock-up service. They are capable of controlling pressure at very low flows such as standing pilots, but should not be used as a line gas pressure regulator for appliances equipped with electronic ignition unless automatic control valve can open against line pressure.

The R & RS series is intended for use with both main burner and pilot load applications. The double diaphragm balanced valve design makes it possible to build a regulator physically small in size yet having good capacity characteristics. They are able to maintain steady outlet pressure control with widely varying inlet pressures. The high quality molded balancing diaphragm eliminates the inlet pressure effect acting on the valve.

R&RS series



balanced valve design

The housings are rugged aluminum die castings. All internal components are carefully selected and corrosion resistant. The diaphragms are of high quality supported synthetic rubber components having excellent low temperature performance. The RS models incorporate a resilient chemically bonded synthetic rubber ring on the valve member. The soft seating insures satisfactory pilot control at inlet pressures up to 5 psi.

These regulators are ideally suited for use with infrared heaters and pilot lines on large industrial heaters and boilers. They may also be used in residential applications. Because of their high pressure drop capacities, both the R & RS models will operate satisfactorily on domestic as well as elevated pressures. Appliances may be shipped to any area having supply pressures from 7.0" w.c. to 5 psi without changing regulators. They find wide applications on commercial and industrial equipment, especially where precise outlet pressure accuracy is required.

Any of the R models can be furnished for zero governor applications.

Specifications

REGULATORS FOR ZERO GOVERNOR APPLICATIONS:

R400Z, R500Z & R600Z – These regulators are equipped with a counter spring beneath the valve for zero governor use in the normal upright position.

A maximum inlet pressure of 1 psi is recommended, and outlet pressure may be adjusted from -1.0" to +1.5" w.c.

At any given flow rate the regulation accuracy is +/- 0.2" w.c. over varying inlet pressures up to 1 psi.

See Bulletin MS 2043

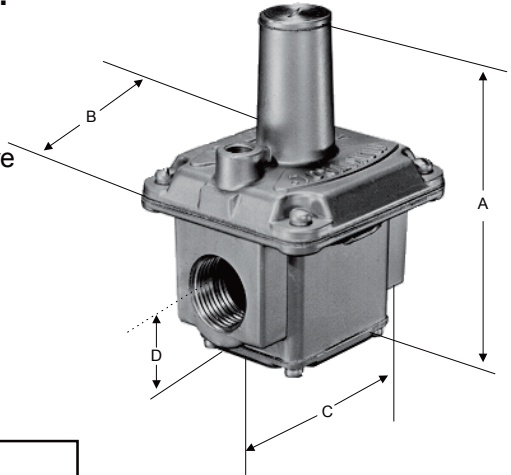

DIMENSIONS – in inches (millimeters)

Swing Model Number	Radius	Call-Outs			
		A	B	C	D
R400 & R400S	2.38 (60)	3.25 (83)	2 (51)	2 (51)	.94 (24)
R500 & R500S	3.56 (90)	4.69 (119)	3.13 (79)	3 (76)	1.19 (30)
R600 & R600S	4.32 (109.7)	5.68 (144.3)	3.88 (98.3)	4.03 (102.4)	1.46 (37.1)

SPRING SELECTION CHART – in inches (mbar)

Model Number with Standard Spring		Other Springs Available							
R400 & R400S	3 to 6	1 - 3.5 (2.5 - 9)	2 - 5 (5 - 12.5)	3 - 8 (7.5 - 20)	—	4 - 12 (10 - 30)	5 - 12 (12.5 - 30)	10 - 22 (25 - 55)	—
R500 & R500S	3 to 6	1 - 3.5 (2.5 - 9)	2 - 5 (5 - 12.5)	3 - 8 (7.5 - 20)	4 - 8 (10 - 20)	4 - 12 (10 - 30)	5 - 12 (12.5 - 30)	10 - 22 (25 - 55)	—
R600 & R600S	3 to 6	2 - 5 (5 - 12.5)	2 - 5 (5 - 12.5)	3 - 8 (7.5 - 20)	4 - 8 (10 - 20)	4 - 12 (10 - 30)	5 - 12 (12.5 - 30)	10 - 22 (25 - 55)	15 - 30 (38 - 75)

CAPACITIES — expressed in CFH (m³ /h) @ 0.64 sp gr gas

Model Number and Pipe Size		Pressure Drop inches w.c. (mbar)										
		0.2 (.50)	0.4 (1.00)	0.6 (1.5)	0.8 (2.0)	1.0 (2.5)	1.5 (3.7)	2.0 (5.0)	2.5 (6.2)	3.0 (7.5)	3.5 (8.7)	4.0 (10.0)
R400 & R400S	3/8 x 3/8	77 (2.16)	110 (3.08)	134 (3.75)	155 (4.34)	174 (4.87)	212 (5.94)	245 (6.86)	274 (7.67)	—	—	—
	1/2 x 1/2	86 (2.41)	121 (3.39)	148 (4.14)	172 (4.82)	192 (5.38)	235 (6.58)	271 (7.59)	303 (8.48)	—	—	—
R500 & R500S	1/2 x 1/2	163 (4.56)	231 (6.47)	283 (7.92)	327 (9.16)	366 (10.25)	447 (12.52)	516 (14.55)	577 (16.16)	635 (17.78)	685 (19.18)	730 (20.44)
	3/4 x 3/4	196 (5.49)	277 (7.76)	340 (9.52)	392 (10.97)	438 (12.26)	537 (15.04)	620 (17.36)	693 (19.40)	760 (21.28)	820 (22.96)	876 (24.53)
R600 & R600S	3/4 x 3/4	298 (8.34)	421 (11.79)	516 (14.45)	595 (16.66)	666 (18.65)	816 (22.85)	942 (26.38)	1,054 (29.51)	1,150 (32.20)	1,245 (34.86)	1,335 (37.38)
	1 x 1	330 (9.24)	468 (13.10)	572 (16.02)	661 (18.21)	739 (20.69)	906 (25.37)	1,046 (29.29)	1,169 (32.73)	1,280 (35.84)	1,380 (38.64)	1,480 (41.44)

Maxitrol Company
23555 Telegraph Rd., P.O. Box 2230
Southfield, MI 48037-2230 U.S.A.
www.maxitrol.com

MAXITROL

Page 31 of 70

© 2006, Maxitrol Company, All Rights Reserved.

European Representatives
Warnstedter Strasse 3 06502 Thale, Germany
49.3947.400.0 • Fax 49.3947.400.200
Industriestrasse 1 48308 Sundern, Germany
49.2597.9632.0 • Fax 49.2597.9632.99



FIREYE M4RT1

FLAME SAFEGUARD CONTROLS



WARNING: Selection of this control for a particular application should be made by a competent professional, licensed by a state or other government agency. Inappropriate application of this product could result in an unsafe condition hazardous to life and property.

DESCRIPTION

The Fireye® M4RT1 Flame Safeguard Control is a compact burner management system. It is designed to provide automatic ignition and continuous flame monitoring for commercial sizes of heating and process burners that use gaseous fuels.

Flame monitoring is accomplished by a Flame Rod detector, the built in amplifier and programmer. Control functions and timing are factory set with onboard jumpers. Functions such as recycle/non-recycle, purge timing, and pilot trial for ignition (P.T.F.I.) time are determined by the jumpers. Flame Failure Response Time (F.F.R.T.) is fixed at three seconds. LED indicator lights indicate the operating status of the control.

In the event of ignition failure, or following a safety shutdown, the unit locks out, activating an alarm circuit. Cycling the power OFF and back on will reset the control. A manual reset option can be special ordered. Remote reset (via remote pushbutton) is also available as a special order option. A detailed description of the programmer sequence is found later in this document. Test jacks are provided to permit flame signal measurement during operation.

The M4RT1 control incorporates a safety checking circuit that is operative on each start. If flame (real or simulated) is detected prior to a start or during the purge, the fuel valves will not be energized, and the unit will lock out.

All M4RT1 controls do not require a wiring base due to the terminals included on the relay board. See **INSTALLATION OF CONTROL, SCANNERS, AND FLAME DETECTORS** (page 2) for temperature and wiring requirements.



SPECIFICATIONS

Supply:

120V (min. 102, max. 132) 60 Hz

Table 1: AMBIENT TEMPERATURE LIMITS

	MAXIMUM		MINIMUM	
Control	125°F	(52°C)	- 40°F	(- 40°C)
Flame Rod (Tip 2460 F)	1500°F	(816°C)	- 40°F	(- 40°C)

Power Consumption: 12 VA (Operating)

Shipping Weight (Approx.): 2.2 lbs. (1.4kg)

Table 2: LOAD RATINGS

Fireye Terminal	Typical Load	Maximum Rating & 120V 60 Hz
3 or 4 Individual or combined	Pilot valve(s) Solenoid valve Ignition Transformer	125 VA pilot duty (solenoid valve) plus 250 VA (Transformer)
5	Main Fuel Valve(s)	125 VA pilot duty (solenoid) or 25 VA pilot duty (solenoid) and 400 VA (opening) motorized
8	Motor or contactor	Motor normally energized and de-energized by the operating control whose rating must be suitable. Terminal 8 rated to de-energize 9.8 FLA, 58.8 LRA, on safety lockout.
A	Alarm	50 VA, pilot duty
Minimum load requirement = 100mA		

APPROVALS

Underwriters Laboratories Inc.

Recognized Components Guide MCCZ2

File MP1537

FM Approvals

FM7610

ORDERING INFORMATION

CONTROL:

M4RT1 120 VAC (min.102, max 132) Supply, 60 Hz.

FLAME DETECTORS:

69ND1-1000K4 12 inch flame rod, 1/2" NPT connector

69ND1 -1000K6 18 inch flame rod, 1/2" NPT connector

69ND1-1000K8 24 inch flame rod, 1/2" NPT connector

INSTALLATION OF CONTROL, SCANNERS, AND FLAME DETECTORS

Wiring Base

Mount the control in an enclosure/burner panel that provides the proper protection for the control. The location should be free from moisture, excessive vibration and within the specified ambient temperature rating. The control may be mounted in any angular position.

All wiring should comply with applicable electrical codes, regulations, and local ordinances. Use moisture resistant wire suitable for at least 90 degrees C. Circuit recommendations are found on pages 10 through 11. Consult the factory for assistance with non-standard applications.



WARNING: Installer must be trained and qualified. Follow the burner manufacturer's instructions, if supplied. Otherwise, proceed as follows.

WARNING: Controls require safety limits utilizing isolated mechanical contacts. Solid state limit switches are not acceptable and should not be used due to their high leakage currents.

WARNING: Remove power from the control before proceeding.

Replaceable Fuse

The M4RT1 is designed with a field replaceable fuse. The fuse is located on the printed circuit board. The fuse will blow as a result of an overload condition on Terminals 3, 4 or 5. To replace the fuse, remove power from the system. Using a small screwdriver or similar tool, remove the fuse from its holder. Install a Fireye replacement fuse (P/N 23-176) or equivalent 8 amp fuse (e.g. Little-fuse 225008P, 8 amp, 125V).



WARNING: Turn off the power when installing or removing the control.

INSTALLATION - 69ND1 FLAME ROD

The 69ND1 flame rod proves a gas pilot flame and/or main gas flame. It is a *spark plug* type unit consisting of $\frac{1}{2}$ " NPT mount, a KANTHAL flame rod, a glazed porcelain insulating rod holder and a spark plug connector for making electrical connections. The 69ND1 is available in 12," 18" or 24" lengths.

The flame rod may be located to monitor only the gas pilot flame or both the gas pilot and main gas flames. It is mounted on a $\frac{1}{2}$ " NPT coupling.

The following instructions should be observed:

1. Keep flame rod as short as possible.
2. Keep flame rod at least $\frac{1}{2}$ " from any refractory.
3. Flame rod should enter the pilot flame from the side so as to safely prove an adequate pilot flame under all draft conditions.
4. If the flame is nonluminous (air and gas mixed before burning), the electrode tip should extend at least $\frac{1}{2}$ " into the flame, but not more than halfway through.

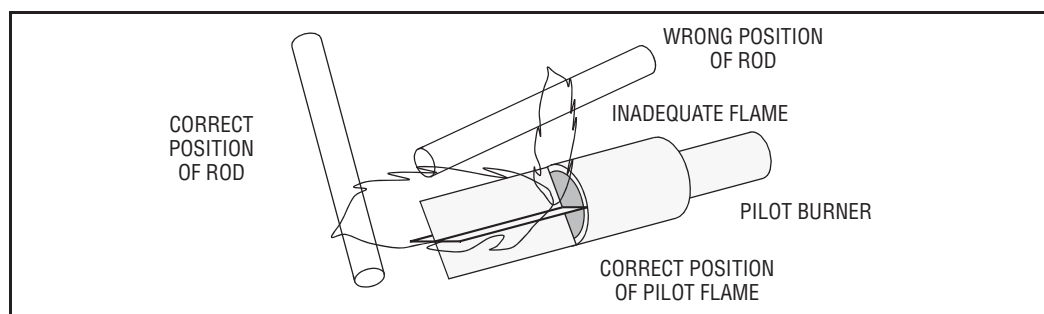

5. If the flame is partly luminous, the electrode tip should extend only to the edge of the flame. It is not necessary to maintain absolutely uninterrupted contact with the flame.
6. It is preferable to angle the rod downward to minimize the effect of sagging and to prevent it from coming in contact with any object.
7. An adequate grounding surface for the flame must be provided. The grounding surface in actual contact with the flame must be at least four times greater than the area of the portion of the flame rod in contact with the flame. It is essential to adjust the flame rod and ground area ratio to provide a minimum signal reading of 6.0 VDC.

Note: Interference from the ignition spark can alter the true signal reading by adding to, or subtracting from it. This trend sometimes may be reversed by interchanging the primary wires (line voltage) to the ignition transformer. This interference can also be reduced by the addition of grounded shielding between the flame rod and ignition spark.

8. Proven types of flame grounding adapters, as shown below, may be used to provide adequate grounding surface. High temperature stainless steel should be used to minimize the effect of metal oxidation. This assembly may be welded directly over the pilot or main burner nozzle.

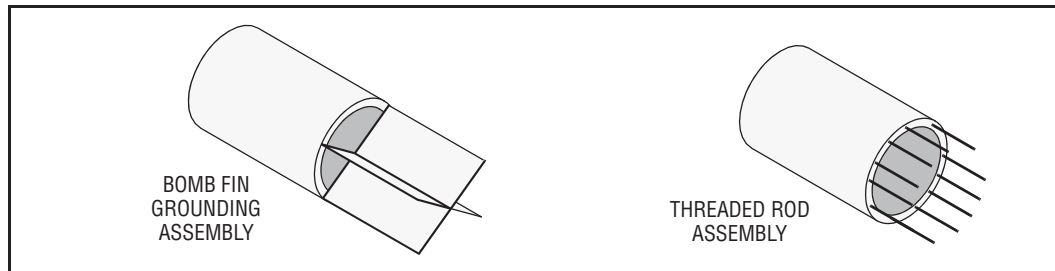

WIRING OF FLAME RODS

For proper operation of flame rectification systems, it is necessary to maintain at least 20 megohms insulating resistance in the flame rectification circuit.

1. The scanner should be wired using metal cable or rigid conduit.
2. High voltage wiring must not be installed in the same conduit with scanner wiring.

Selection of Scanner Wire

1. Use #14, 16, or 18 gauge wire with 90 C, 600 volt insulation for up to 20 feet distance.
2. The type of insulation used with flame rectification is important, since it must protect against current leakage resistance to ground. Use Belden 8254-RG62 Coaxial Cable (or equal) for runs greater than 20 feet. **Maximum wiring run not to exceed 100 feet.**

MAINTENANCE

Type 69ND1 Flame Rod

The flame rod and its insulator should be kept clean by washing routinely with soap and water. Rods should be routinely replaced as they oxidize.

Flame Signal Strength

Routine observation of the flame signal strength will forewarn any deterioration in the capability of the flame detector or its application.

Periodic Safety Check

It is recommended that a procedure be established to test the complete flame safeguard system at least once a month. This test should verify the proper operation of all limit switches and safety interlocks as well as flame failure protection and fuel safety shutoff valve tightness.

RESET

In the event of a lockout condition, the M4RT1 can be reset via a minimum one second power interruption to terminal 7.

RESET OPTIONS (Special Order)

1. Optional M4RT1 reset push button. When this optional reset pushbutton is installed, the M4RT1 can be reset by depressing this button for a minimum of one second.
2. Remote reset option. With this option, the M4RT1 is provided with two additional screw terminals. Using those terminals, a remote, dry contact pushbutton switch can be connected. The maximum wire length is 100 feet (no.18 AWG wire size is recommended).



CAUTION: Remote reset is recommended only on a control solely for proved ignition programming (pilot ignited burner) or a control for use only with appliances in which unburned fuel cannot accumulate and that is intended for installation in inaccessible locations such as open-flame, ceiling-suspended gas heaters.



WARNING: Selection of the Purge time and Recycle / Non-Recycle operation for a particular application, by changes to the factory default jumpers described below, should only be performed by a competent professional, licensed by a state or other government agency. Inappropriate selection of these safety critical parameters could result in an unsafe condition hazardous to life and property.

PROGRAMMER JUMPER SETTINGS

The M4RT1 has a series of 8 jumpers that are used to configure the Purge timing, Pilot Trial for Ignition (PTFI) timing, and recycle or non-recycle operation.

Purge Timing

Jumpers JP1 through JP5 are used to select the Purge timing for the M4RT1. The available Purge timing selections are 5, 7, 30, 60, and 240 seconds and any additive combination of those times. Selecting two or more Purge timing jumpers will result in a Purge time period equal to the sum of the jumpers selected. Selection of a Purge time is accomplished by cutting or not installing the associated jumper. The factory set, default Purge time of 5 seconds (JP1 not installed) is always selected.

The Table below lists all available Purge times and how to select those by cutting jumpers JP2 through JP5.

Purge Time (seconds)	JP2	JP3	JP4	JP5
5	Installed	Installed	Installed	Installed
12	Cut	Installed	Installed	Installed
35	Installed	Cut	Installed	Installed
42	Cut	Cut	Installed	Installed
65	Installed	Installed	Cut	Installed
72	Cut	Installed	Cut	Installed
95	Installed	Cut	Cut	Installed
102	Cut	Cut	Cut	Installed
245	Installed	Installed	Installed	Cut
252	Cut	Installed	Installed	Cut
275	Installed	Cut	Installed	Cut
282	Cut	Cut	Installed	Cut
305	Installed	Installed	Cut	Cut
312	Cut	Installed	Cut	Cut
335	Installed	Cut	Cut	Cut
342	Cut	Cut	Cut	Cut



Pilot Trial for Ignition

Jumpers JP6 and JP7 are used by the factory only to select the PTFI for the M4RT1. The available PTFI timing selections are 5 and 10 seconds. The factory set, default PTFI time is 10 seconds (JP6 installed, JP7 not installed). The PTFI time may only be set by the factory.

Recycle/Non-recycle Operation

Jumper JP8 is used to select either Recycle or Non-Recycle operation of the M4RT1. The factory set, default is Recycle operation (JP8 installed). To select Non-Recycle operation, cut jumper JP8.

LED INDICATOR LIGHTS

The M4RT1 has 5 LED lights to indicate the operating status of the control. The function of these lights are:

Opr Ctrl (Operating Control): This LED is lighted whenever input terminal 7 is energized. The burner system safety interlocks and operating control should be wired in series and connected to the M4RT1 terminal 7.

Air Flow: This LED is lighted whenever all of these conditions exist:

- Input terminal 7 is energized (operating control and safety interlocks closed).
- Input terminal 6 is energized (proof of airflow switch is closed).
- Output terminal 8 is energized (blower motor).

PTFI: This LED is energized only during the Pilot Trial For Ignition Period.

Flame: This LED is lighted whenever an adequate flame signal is detected between the M4RT1 terminals S1 & S2.

Alarm: This LED is energized whenever a safety lockout occurs. (See APPLICATION AND FUNCTION section).

NOTE: The M4RT1 is not powered until the user's operating control is energized.

APPLICATION AND FUNCTION

The M4RT1 provides prepurge, ignition and flame safeguard for heating and process gas fired burners. The “recycle” or “non-recycle” operation is determined by the #8 jumper on the top PCB. Purge timing, as well as trial for ignition timing is also set by the jumpers. See JUMPER SETTINGS on page 5.

The M4RT1 amplifier circuitry is designed to utilize a flame rod for flame detection. The Flame Failure Response Time (F.F.R.T.) is fixed at 3 seconds.

Pilot Ignited Burners - “Recycle” Operation

With jumper #8 in the “recycle” position, the typical wiring arrangement illustrated on page 10 for pilot ignited burners provides the following function:

1. With power applied to Terminal 7 (Opr Ctrl LED lighted), the burner motor circuit (Terminal 8) is energized. The control then waits for the proof of airflow input (Terminal 6) to be energized
2. The Pre-Purge timing starts when terminal 6 is energized.
3. Following the prepurge period (as determined by jumpers #1 through #5), KL-1 closes, energizing Terminal 3 which powers the pilot gas valve and Terminal 4 which powers the spark ignition. A five or ten sec. (as determined by jumpers #6 or #7) trial for ignition is initiated (PTFI LED lit).
4. When pilot flame is detected (Flame LED lit), KF-1 closes, energizing Terminal 5 which powers the main fuel valve, KF-2 opens de-energizing Terminal 4 which shuts off the spark ignition.
5. When the operating control opens its circuit, or if a power failure occurs, the entire system is de-energized. Power interruptions in the millisecond range do not affect the operation of the control. Power interruptions of longer duration will cause the control to recycle.



6. In the event the pilot flame is not detected by the end of trial for ignition period (PTFI), the pilot gas valve (Terminal 3) and spark ignition (Terminal 4) are de-energized. A safety shutdown occurs followed in approximately 30 seconds by a safety lockout that de-energizes the blower motor (Terminal 8) and energizes the lockout alarm circuit (Alarm LED lighted).
7. In the event of a flame failure during a firing period, the pilot and main fuel valves are de-energized. Following the prepurge period (as determined by jumpers #1 through #5), with proven air flow (Air Flow LED lit), the pilot gas valve and spark ignition are re-energized and a five or ten sec. (as determined by jumpers #6 or #7) trial for ignition is initiated (PTFI LED lit). If pilot flame is detected (Flame LED lit), the main fuel valve is energized, the spark ignition is de-energized. In the event the pilot flame is not detected by the end of trial for ignition period (PTFI), the pilot gas valve (Terminal 3) and spark ignition (Terminal 4) are de-energized. A safety shutdown occurs followed in approximately 30 seconds by a safety lockout that de-energizes the blower motor (Terminal 8) and energizes the lockout alarm circuit (Alarm LED lighted).
8. Manual Reset (supply power cycled off/on) is required following any safety lockout.

NOTE: Wait 10 seconds after lockout before restarting the control.

Pilot Ignited Burners - “Non-recycle” Operation

The function of “non-recycle” pilot ignited burners is the same as described for the “recycle” controls, except that the “non-recycle” operation will lock out following any flame failure. “Recycle” or “non-recycle” operation is determined by the position of jumper #8. See Programmer jumper settings on page 5.

Direct Spark Ignited Burners - “Recycle” Operation

With jumper #8 in the “recycle” position, the typical wiring arrangement illustrated on pages 10 and 11 for direct spark ignited burners provides the following function:

1. With power applied to Terminal 7 (Opr Ctrl LED lighted), the burner motor circuit (Terminal 8) is energized. The control then waits for the proof of airflow input (Terminal 6) to be energized.
2. The Pre-Purge timing starts when terminal 6 is energized.
3. Following the selected prepurge period (as determined by jumper #1 through #5), KL-1 closes, energizing Terminal 3 which powers the primary main fuel valve, and Terminal 4 which powers the spark ignition. A five or ten second (as determined by jumper #6 and #7) trial for ignition is initiated (PTFI LED lit).
4. When pilot flame is detected (**Flame** LED lit), KF-1 closes, energizing Terminal 5 which powers the secondary main fuel valve, and KF-2 opens, de-energizing Terminal 4 which shuts off the spark ignition.
5. When the operating control opens its circuit, or if a power failure occurs, the control is de-energized. Power interruptions in the millisecond range do not affect the operation of the control. Power interruptions at longer duration will cause the control to recycle.
6. In the event the pilot flame is not detected by the end of trial for ignition period (PTFI), the pilot gas valve (Terminal 3) and spark ignition (Terminal 4) are de-energized. A safety shutdown occurs followed in approximately 30 seconds by a safety lockout that de-energizes the blower motor (Terminal 8) and energizes the lockout alarm circuit (Alarm LED lighted).

Direct Spark Ignited Burners - “Non-recycle” Operation

The function of “non-recycle” direct spark ignited burners is the same as described for the “recycle” controls, except that the “non-recycle” operation will lock out following any flame failure. “Recycle” or “non-recycle” operation is determined by the position of jumper #8. See Programmer Jumper Settings on page 5.



TIMING CHART

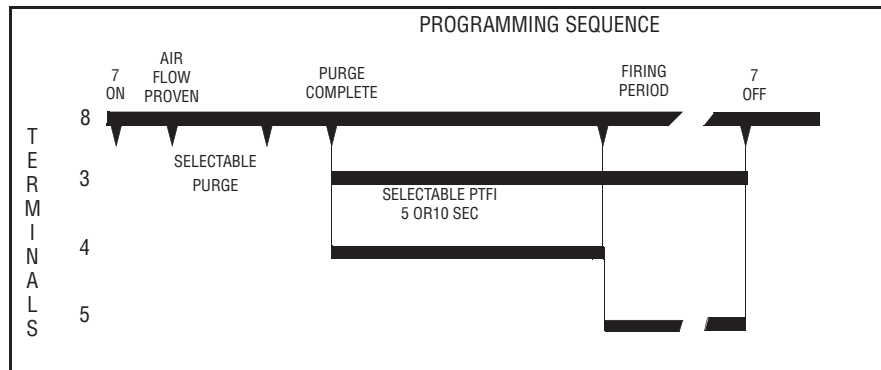

Selectable Recycle/Non-Recycle operation on loss of flame after Terminal 5 energized. Recycle on loss of air flow after flame proven.

INSTALLATION TESTING

Use of Test Meter

Testing the Fireye M4RT1 Control requires the use of a test AC-DC multimeter, with a 1,000 ohm/volt DC rating or greater, or a digital meter with 500K input impedance or greater.

With the test meter on the DC scale, and the test meter leads inserted into the test jacks. A **steady DC** voltage reading of **6 to 18 volts** should be obtained when the control is detecting flame, and zero volts when no flame is present.

With the test meter on the AC scale, line and load voltages may be measured at the identified test points on the chassis.

On the M4RT1 control, a micro-ammeter may be connected in series with the wire to Terminal S2. Normal flame will produce a meter reading between 4 and 10 micro-amperes.

Flame Signal Testing

1. Manually shut off the main fuel valve for a pilot ignited burner, or the secondary fuel valve for a direct spark ignited burner.
2. Set the test meter on the DC scale and insert the test leads into the test jacks on the amplifier module. (If the meter reads backwards, reverse the meter leads). Red - Plus, Black - Negative.
3. Initiate a normal startup.
4. When flame is established, the test reading should be normal: a steady DC voltage reading of 6 to 18 volts.
5. Inadequate flame signal may be improved by:
 - a. Assuring that the flame detector and wiring installations have followed the instructions on pages 3 and 4.
 - b. Assuring that the flame detector is clean and within the ambient temperature limits.
 - c. Assuring that the flame is sufficiently large to detect.
 - d. Assuring that the flame quality (fuel to air ratio, combustion air velocity) is satisfactory.

Minimum Pilot Test

This test insures that the flame detector will not sense a pilot flame too small to light the main flame reliably. It must be made on every new installation as well as following the repositioning of the flame detector. **This procedure should not be used on a direct spark ignited burner.**

1. Manually shut off the fuel to the main burner.
2. Connect a test meter to the test jacks.
3. Initiate a normal startup.
4. Reduce the fuel to the pilot until the DC voltmeter reads approximately 6 volts or when the pilot is at the minimum to provide a reliable main flame light-off. See WARNING below. This is the minimum pilot.
5. Slowly turn on the main fuel and insure that the main flame lights off promptly and normally.



WARNING: If light off is delayed, shut off the power to the installation. Realign the flame detector so that pilot flame detection requires a larger pilot flame. Repeat this test until the main flame lights reliably with minimum pilot.

WARNING: The minimum pilot test must be accomplished by a trained and qualified burner technician.

6. After the minimum pilot test is completed satisfactorily, increase the pilot flame to normal size, and observe that the main flame is properly established during a normal cycle ("Run-Check" switch in the "Run" position).

Flame Failure Test

1. Temporarily connect spark ignition and pilot valve to Terminal #3.
2. Initiate a normal startup.
3. Manually shut off all fuel and observe the loss of flame signal on the test meter.
4. If flame signal does not reduce to zero within the flame failure response time of the control, a grounded metallic shield may need to be inserted between the flame rod and spark ignition to prevent interference.



5. **IMPORTANT:** When the test is completed, reconnect the spark ignition to Terminal #4.

FIGURE 1. TYPICAL WIRING ARRANGEMENT FOR PILOT IGNITED BURNER.

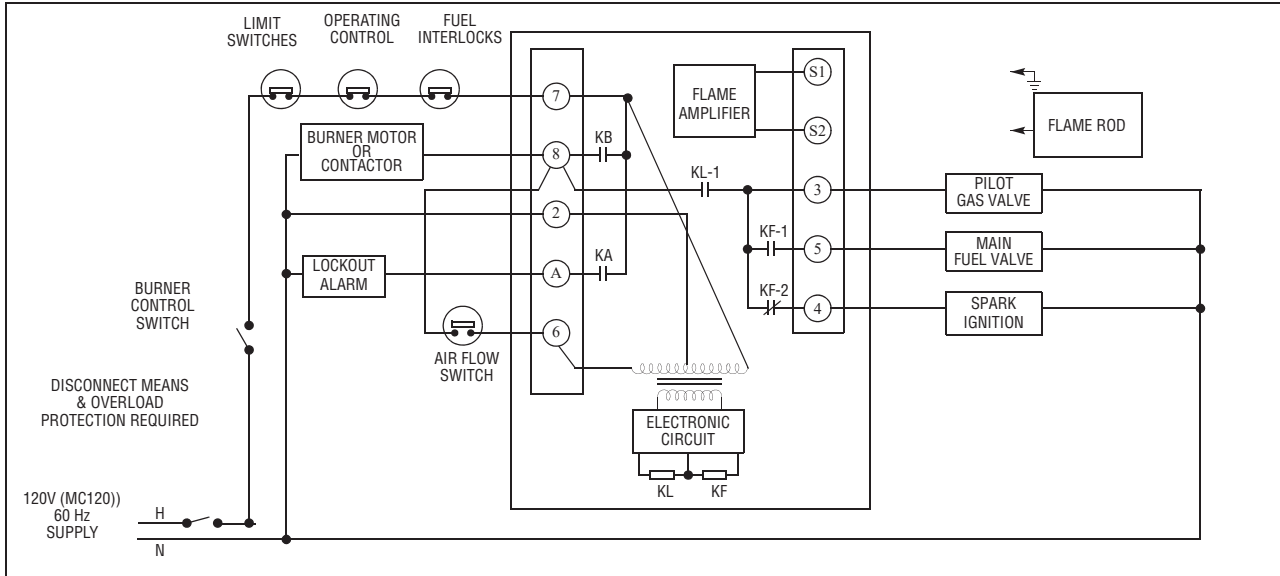

Use moisture resistant wire suitable for at least 90°C.



CAUTION: When powered, 260 VAC across S1, S2.

FIGURE 2. TYPICAL WIRING ARRANGEMENT FOR DIRECT SPARK IGNITED BURNER

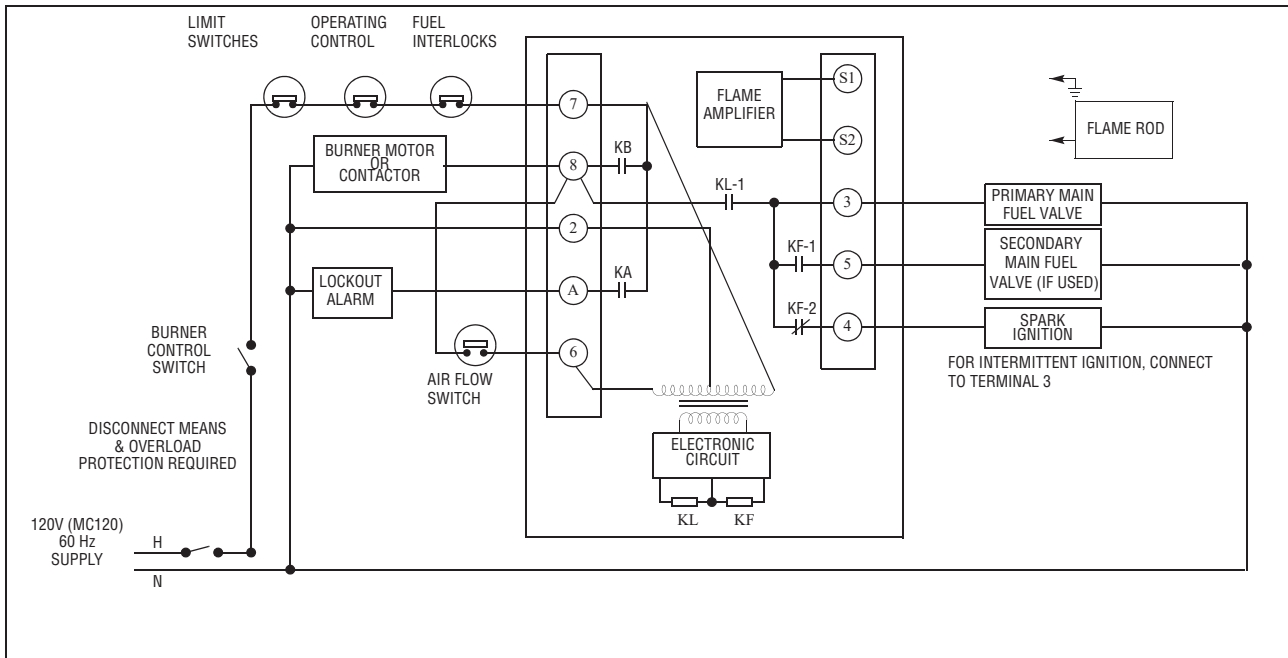

Use moisture resistant wire suitable for at least 90°C.



CAUTION: When powered, 260 VAC across S1, S2.



CAUTION: Control wiring procedures which deviate from those shown in the diagrams may bypass safety functions designed in the control. Check with the Fireeye Representative before deviating from the recommended wiring diagrams.

FIGURE 3. ALTERNATE WIRING ARRANGEMENT

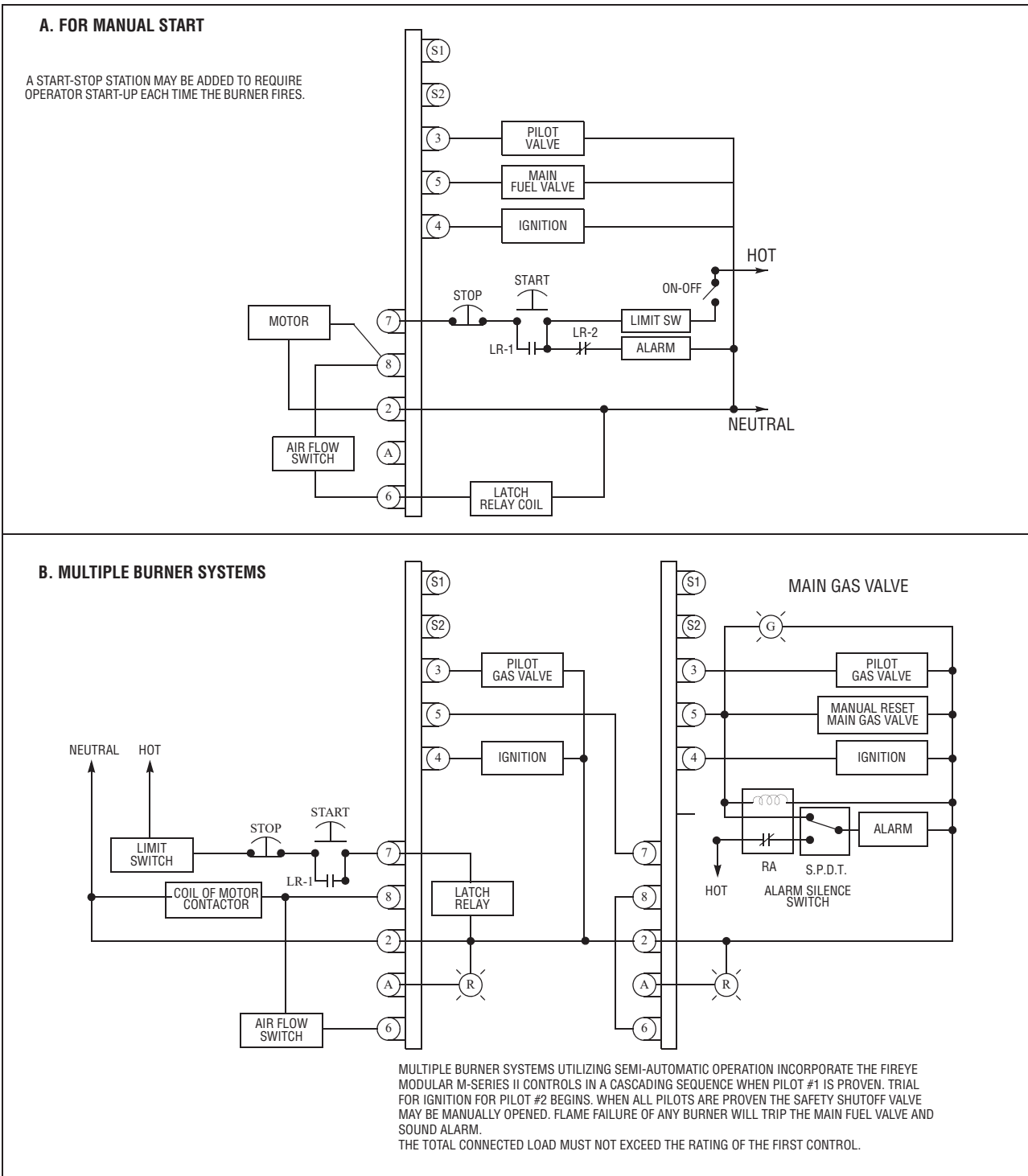

Use moisture resistant wire suitable for at least 90°C.



CAUTION: Control wiring procedures which deviate from those shown in the diagrams may bypass safety functions designed in the control. Check with the Fireye Representative before deviating from the recommended wiring diagrams.



NOTICE

When Fireeye products are combined with equipment manufactured by others and/or integrated into systems designed or manufactured by others, the Fireeye warranty, as stated in its General Terms and Conditions of Sale, pertains only to the Fireeye products and not to any other equipment or to the combined system or its overall performance.

WARRANTIES

FIREYE guarantees for *one year from the date of installation or 18 months from date of manufacture* of its products to replace, or, at its option, to repair any product or part thereof (except lamps, electronic tubes and photocells) which is found defective in material or workmanship or which otherwise fails to conform to the description of the product on the face of its sales order. **THE FOREGOING IS IN LIEU OF ALL OTHER WARRANTIES AND FIREYE MAKES NO WARRANTY OF MERCHANTABILITY OR ANY OTHER WARRANTY, EXPRESS OR IMPLIED.** Except as specifically stated in these general terms and conditions of sale, remedies with respect to any product or part number manufactured or sold by Fireeye shall be limited exclusively to the right to replacement or repair as above provided. In no event shall Fireeye be liable for consequential or special damages of any nature that may arise in connection with such product or part.



FIREYE
3 Manchester Road
Derry, New Hampshire 03038
www.fireeye.com

M-4000
APRIL 16, 2013
Supersedes July 15, 2011

C6097A,B Pressure Switches

PRODUCT DATA



APPLICATION

The C6097 Pressure Switches are safety devices used in positive-pressure or differential-pressure systems to sense gas or air pressure changes.

FEATURES

- For use with natural gas, liquid propane (LP) gas, or air.
- Diaphragm-actuated safety-limit switch.
- Switch can be wired to turn on alarm.
- C6097A models break control circuit at setpoint on pressure fall.
- C6097B models break control circuit at setpoint on pressure rise.
- Lockout with manual reset and recycle options.
- Lockout models have external manual reset button.
- Removable transparent cover protects scaleplate and adjusting knob.
- Pipe tapings allow selection of positive pressure, differential pressure (air only) or venting connections (NPT mount only).
- 1/4 in. NPT or flange mount models for direct mounting to Honeywell Integrated Valve Train.
- Optional switch position indicator lamp available.
- IP54 enclosure standard.
- Ranges: 0.4 to 5 in. wc, 3 to 21 in. wc, 12 to 60 in. wc or 1.5 to 7 psi.
- Surge orifice.

Contents

Application	1
Features	1
Specifications	2
Ordering Information	2
Installation	4
Wiring	5
Settings and Adjustments	5
Operation and Checkout	6



SPECIFICATIONS

Models:

C6097A Pressure Switch: Breaks a circuit when pressure falls to scale setting. See Table 1.

C6097B Pressure Switch: Breaks a circuit when pressure rises to scale setting. See Table 1.

Table 2 shows switch ratings and Table 3 shows alternate electrical ratings when used with Honeywell Flame Safeguard Programmers.

Minimum Ambient Temperature: -40°F (-40°C).

Maximum Ambient Temperature: 140°F (60°C).

Connections (Depending on Model):

1/4-18 NPT tapping for main or high-pressure connection.
1/8-27 NPT tapping for vent or low-pressure connection (air only).

Flange mount for connection to Honeywell Integrated Valve Train (internal vent only, no external connections).

Scale Range:

0.4 to 5 in. wc (0.10 kPa to 1.25 kPa).

3 to 21 in. wc (0.75 to 5.23 kPa).

12 to 60 in. wc (3.0 kPa to 15 kPa).

1.5 to 7 psi (10.3 kPa to 48 kPa).

Approvals:

Underwriters Laboratories Inc. listed.

Canadian Standards Association listed.

Factory Mutual: Approved.

Industrial Risk Insurers: Acceptable.

CSD-1 AFB: Acceptable.

Accessories:

32003041-001 C6097 Cover for manual reset models.

32003040-001 C6097 Cover for recycle models.

32003039-001 Position Indication Lamp Kit.

Dimensions: See Fig. 1 and 2.

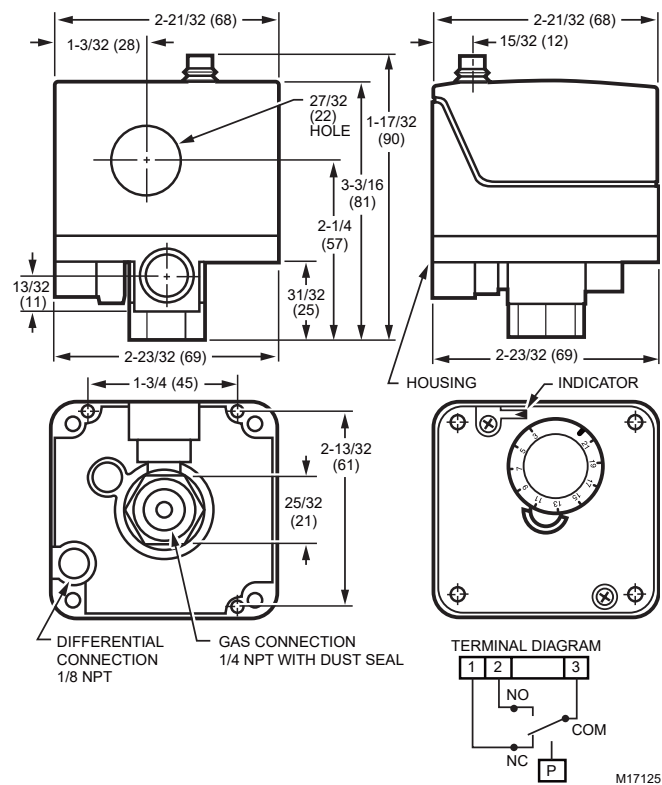

Fig. 1. C6097 1/4 in. NPT Mount dimensions in in. (mm).

ORDERING INFORMATION

When purchasing replacement and modernization products from your TRADELINE® wholesaler or distributor, refer to the TRADELINE® Catalog or price sheets for complete ordering number.

If you have additional questions, need further information, or would like to comment on our products or services, please write or phone:

1. Your local Home and Building Control Sales Office (check white pages of your phone directory).
2. Home and Building Control Customer Logistics
Honeywell Inc., 1885 Douglas Drive North
Minneapolis, Minnesota 55422-4386 (612) 951-1000

In Canada—Honeywell Limited/Honeywell Limitée, 155 Gordon Baker Road, North York, Ontario M2H 3N7.

International Sales and Service Offices in all principal cities of the world. Manufacturing in Australia, Canada, Finland, France, Germany, Japan, Mexico, Netherlands, Spain, Taiwan, United Kingdom, U.S.A.

Table 1. Pressure Switch Model Selection.

Model	Operating Pressure Range	Manual Reset Differential		Non-Manual Reset Differential		Differential Type	Maximum Rated Pressure (continuous) (psi)	Manual Reset	Media ^a	Switch Action at Setpoint	Comments
		Maximum at Minimum Setpoint	Maximum at Maximum Setpoint	Nominal	Maximum						
C6097A1004	0.4 to 5 in. wc	—	—	0.16 in. wc	0.24 in. wc	Additive	2.9	No	Air/Gas	Breaks N.O. to C. connection on pressure fall.	1/4 in. NPT Mount
C6097A1012	3 to 21 in. wc	2.4 in. wc	4.2 in. wc	—	—		4.3	Yes	Air/Gas		1/4 in. NPT Mount
C6097A1020	3 to 21 in. wc	2.4 in. wc	4.2 in. wc	—	—		4.3	Yes	Air/Gas		Flange Mount
C6097A1038	12 to 60 in. wc	10 in. wc	12 in. wc	—	—		4.8	Yes	Air/Gas		1/4 in. NPT Mount
C6097A1046	12 to 60 in. wc	10 in. wc	12 in. wc	—	—		4.8	Yes	Air/Gas		Flange Mount
C6097A1053	3 to 21 in. wc	—	—	0.24 in. wc	0.48 in. wc		4.3	No	Air/Gas		1/4 in. NPT Mount
C6097A1061	3 to 21 in. wc	—	—	0.24 in. wc	0.48 in. wc		4.3	No	Air/Gas		Flange Mount
C6097A1079	12 to 60 in. wc	—	—	1.1 in. wc	2.4 in. wc		4.8	No	Air/Gas		1/4 in. NPT Mount
C6097A1087	12 to 60 in. wc	—	—	1.1 in. wc	2.4 in. wc		4.8	No	Air/Gas		Flange Mount
C6097A1095	0.4 to 5 in. wc	0.6 in. wc	1.0 in. wc	—	—		2.9	Yes	Air/Gas		1/4 in. NPT Mount
C6097A1103	1.5 to 7 psi	1.1 psi	1.4 psi	—	—		9.3	Yes	Air/Gas		Flange Mount
C6097A1111	1.5 to 7 psi	1.1 psi	1.4 psi	—	—		9.3	Yes	Air/Gas		1/4 in. NPT Mount
C6097A1129	1.5 to 7 psi	—	—	0.1 psi	0.3		9.3	No	Air/Gas		Flange Mount
C6097A1137	1.5 to 7 psi	—	—	0.1 psi	0.3		9.3	No	Air/Gas		1/4 in. NPT Mount
C6097A1210	0.4 to 5 in. wc	—	—	0.16 in. wc	0.24 in. wc		2.9	No	Air/Gas		Flange Mount
C6097A1228	0.4 to 5 in. wc	—	—	—	—		2.9	Yes	Air/Gas		Flange Mount
C6097B1002	12 to 60 in. wc	10 in. wc	12 in. wc	—	—	Subtractive	4.8	Yes	Air/Gas	Breaks N.C. to C. connection on pressure rise.	1/4 in. NPT Mount
C6097B1010	12 to 60 in. wc	10 in. wc	12 in. wc	—	—		4.8	Yes	Air/Gas		Flange Mount
C6097B1028	3 to 21 in. wc	2.4 in. wc	4.2 in. wc	—	—		4.3	Yes	Air/Gas		1/4 in. NPT Mount
C6097B1036	3 to 21 in. wc	2.4 in. wc	4.2 in. wc	—	—		4.3	Yes	Air/Gas		Flange Mount
C6097B1044	1.5 to 7 psi	1.1 psi	1.4 psi	—	—		21.0	Yes	Air/Gas		Flange Mount
C6097B1051	1.5 to 7 psi	1.1 psi	1.4 psi	—	—		21.0	Yes	Air/Gas		1/4 in. NPT Mount
C6097B1069	3 to 21 in. wc	—	—	0.24 in. wc	0.48 in. wc		4.3	No	Air/Gas		Flange Mount
C6097B1077	12 to 60 in. wc	—	—	1.1 in. wc	2.4 in. wc		4.8	No	Air/Gas		Flange Mount
C6097B1085	12 to 60 in. wc	—	—	1.1 in. wc	2.4 in. wc		4.8	No	Air/Gas		1/4 in. NPT Mount
C6097B1093	1.5 to 7 psi	—	—	0.1 psi	0.3 psi		21.0	No	Air/Gas		Flange Mount
C6097B1101	1.5 to 7 psi	—	—	0.1 psi	0.3 psi		21.0	No	Air/Gas		1/4 in. NPT Mount
C6097B1119	3 to 21 in. wc	—	—	0.24 in. wc	0.48 in. wc		4.3	No	Air/Gas		1/4 in. NPT Mount

^a Acceptable media: Natural gas, liquid propane (LP) gas, and air.

Table 2. Switch Ratings (Amperes)

120/240 Vac, 50/60 Hz		
Inductive	Full Load	3.0
	Locked Rotor	18.0
Resistive		5.0

Table 3. Alternate Electrical Ratings when used with Honeywell Flame Safeguard Programmers.

Device	Rating
Ignition Transformer	540 VA
Pilot Valve	50 VA
Main Valve	400 VA with 2-1/2 times inrush.

When Installing this Product...

1. Read these instructions carefully. Failure to follow them can damage the product or cause a hazardous condition.
2. Check the ratings given in the instructions and on the product to make sure that the product is suitable for your application.
3. Installer must be a trained, experienced service technician.
4. After installation is completed, check out product operation as provided in these instructions.

⚠️ WARNING

Electrical Shock Hazard.

Can cause serious personal injury or death.

Disconnect power supply before beginning installation. More than one disconnection can be involved.

Mounting

NOTE: On flange models, remove the label holding the O-ring in place and make sure O-ring seal is in place before mounting the pressure switch on the valve.

The C6097 models allow NPT or flange (directly to valve) mounting. The NPT models have a hexagonal fitting with a 1/4 in. NPT tapping, which is the high pressure connection, in differential applications. The bleed fitting is 1/8 in. NPT tapped. In differential pressure control applications using air only, connect the lower pressure to the bleed fitting. See Fig. 1 and Table 1. In applications using combustible gases, vent the bleed tapping according to applicable standard code or jurisdictional authority.

C6097 models with flange mount can be fitted directly to Honeywell Integrated Valve Train (model specific). See Fig. 2 and Table 1. The flange mount models vent internally, with no external tap.

Mount the C6097A,B in any position.

Leak Check

After installation, perform a leak check on the pressure switch:

1. Turn on main gas. Make sure gas has reached the pressure switch (e.g., high gas pressure switch)
2. Check installation for gas leaks using a gas leak detector or a soap solution.

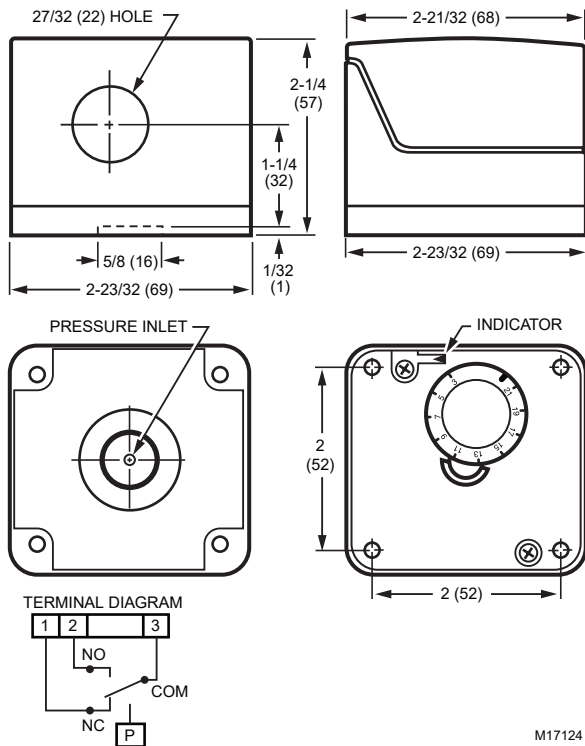

M17124

Fig. 2. C6097 Flange Mount dimensions in in. (mm).

INSTALLATION

⚠️ WARNING

Explosion or Fire Hazard.

Can cause severe personal injury, death or property damage.

Observe all safety requirements each time a control is installed on a burner.

WIRING

⚠ WARNING

Electrical Shock Hazard.
Can cause serious personal injury or death.
 Disconnect power supply before beginning installation.
 More than one disconnection can be involved.

Make sure that all wiring agrees with all applicable local codes, ordinances and regulations. An opening is provided to accommodate rigid conduit or armored cable for line voltage operation (see Fig. 3 and 4). Do not overload the switch contacts (see Switch Ratings in the Specifications section). The switching schematic is shown in Fig. 5.

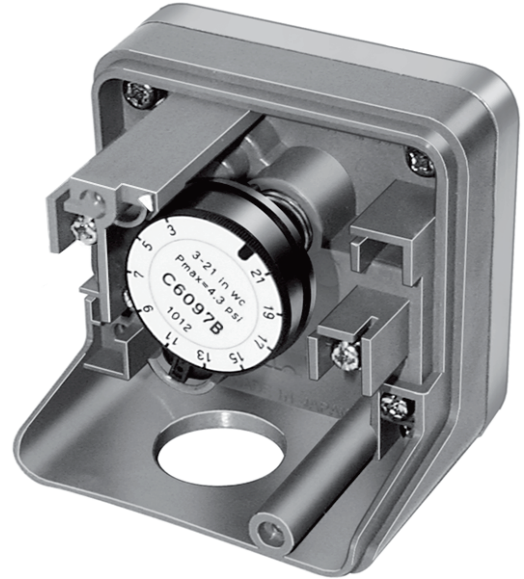



Fig. 4. C6097 (recycle model) with cover removed.

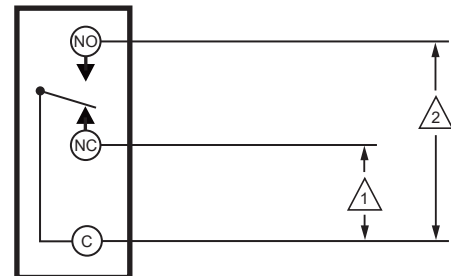

Fig. 3. C6097 (manual reset switch model) with cover removed.

SETTINGS AND ADJUSTMENTS

Pressure Setpoint Adjustment

To adjust the pressure setting, turn the setpoint adjustment dial (Fig. 3, 4 and 5) clockwise  to increase the pressure setting and counterclockwise  to decrease the pressure setting.



1 C6097A BREAKS C-NO, MAKES C-NC ON PRESSURE FALL. MANUAL RESET MODELS LOCK OUT.

2 C6097B BREAKS C-NC, MAKES C-NO ON PRESSURE RISE AND LOCKS OUT.

M17123

Fig. 5. C6097 schematic.

OPERATION AND CHECKOUT

Operation

The manual reset C6097A diaphragm actuates the snap-acting switch to break a control circuit and lock out when pressure falls to the scale setting. The recycle C6097A models recycle automatically when the control circuit returns to scale setting plus differential.

The manual reset C6097B diaphragm actuates the snap-acting switch that breaks a control circuit and locks out when the pressure rises to the scale setting. The recycle C6097B models recycle automatically when the control pressure falls to the scale setting minus differential.

Manual Resetting

The C6097A manual reset models lock out when pressure falls to the scale setting and require manual resetting after the pressure rises to scale setting plus differential to resume normal operation.

The C6097B manual reset models lock out when pressure rises to the scale setting and require manual resetting after the pressure falls to scale setting minus the differential to resume normal operation.

To reset, once normal operating pressure is restored, push the reset button in as far as it goes, then release.

IMPORTANT

Lockout models cannot be made to recycle automatically by permanently holding in the reset lever.

Checkout

C6097 Gas Fuel Application

1. Set cutoff pressure.
2. Open main supply line. Depress reset lever on lockout models until switch makes control circuit.
3. Set controller and limit switch to call for heat.
4. For C6097A: Close the manual gas shutoff valve. C6097 should open control circuit when pressure reaches cutoff point.
For C6097B: Open the manual gas shutoff valve, wait a few minutes for the pressure to rise; then lower the scale setting until the switch breaks control circuit and locks out.
5. For C6097A: Open the shutoff valve, return the pressure switch to its original setting and press the reset button (if necessary).
For C6097B: raise setting to normal and press reset button (if necessary).
6. Allow system to operate through at least one complete cycle to make sure all components are functioning properly.

C6097A Air Application

1. Set cutoff pressure.
2. Turn on fan.
3. Block fan inlet or filter area. Switch should break control circuit when pressure drops to cutoff point. Manual reset models lock out.
4. Remove obstruction. Press reset lever (manual reset models) and allow system to operate through at least one complete cycle to be sure all components are functioning properly.



**CERTIFICATION & SUBMITTAL
MODEL 5900 AIRFOIL BLADE**

**Low Leakage Dampers
Parallel and Opposed Blade**

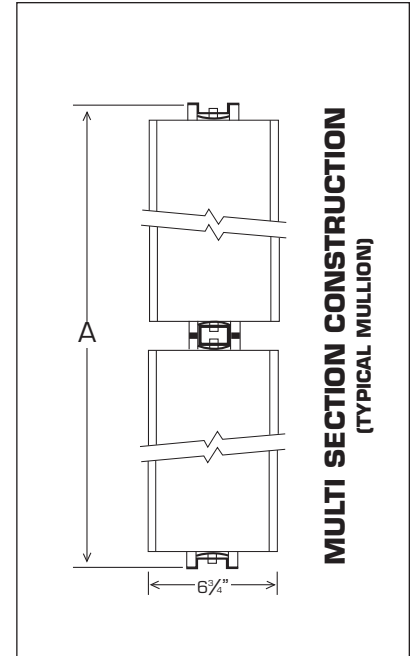
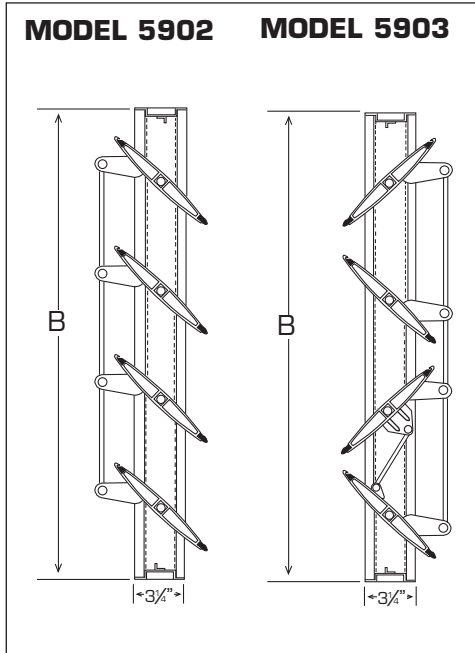

STANDARD SPECIFICATIONS

OPTIONS

- **FRAME:** 14 gauge galvanized press formed steel with welded corners.
- **BLADES:** .081 6063T5 extruded aluminum.
- **AXLES:** 1/2" x 3" long plated steel rods.
- **BEARINGS:** 1/2" diameter self-lubricating porous bronze.
- **BLADE EDGE SEALS:** Santoprene® Thermoplastic Rubber.
- **SIDE SEALS:** Spring stainless steel.
- **CONTROL ROD:** 1/2" diameter x 9" long plated steel.
- **HARDWARE:** Plated steel center brackets, brass pivots, 1/4" or 5/16" diameter plated steel rod.
- **FINISH:** Standard Mill.
- **MAXIMUM TEMPERATURE:** 250°F.
- **MAXIMUM VELOCITY:** 3000 F.P.M.
- **MAX. SINGLE SECTION:** 48" X 72".
- **MINIMUM SIZE:** Model 5901: 8" x 8"
Model 5902: 8" x 14"
Model 5903: 8" x 12"

- 11 Ball Bearings (side seals not available).
- 12 Nylon Bearings (Bushings).
- 13 Stainless Steel Bearings (Bushings).
- 24 Right Angle Mixing Set-up, internal linkage.
- 25 Right Angle Mixing Set-up, external linkage.
- 26 Face & Bypass Set-up, vertical internal linkage.
- 27 Face & Bypass Set-up, vertical external linkage.
- 28 Face & Bypass Set-up, horizontal, internal linkage or jackshaft.
- 31 Flange, 1-1/2" fastened to damper frame (opposite linkage).
- 86 Aluminum Frame Construction.
- 89 Sleeve.
- 90 Jackshaft.
- 92 Actuators.

NOTE: A & B are opening dimensions. Unless otherwise specified, dampers are made 1/4" undersize.

Type text in this area.

**PERFORMANCE DATA
MODEL 5900
Low Leakage Airfoil Dampers**

MODEL 5900 TEST SIZE 24" x 24"

- A. 30° Open
- B. 60° Open
- C. Full Open

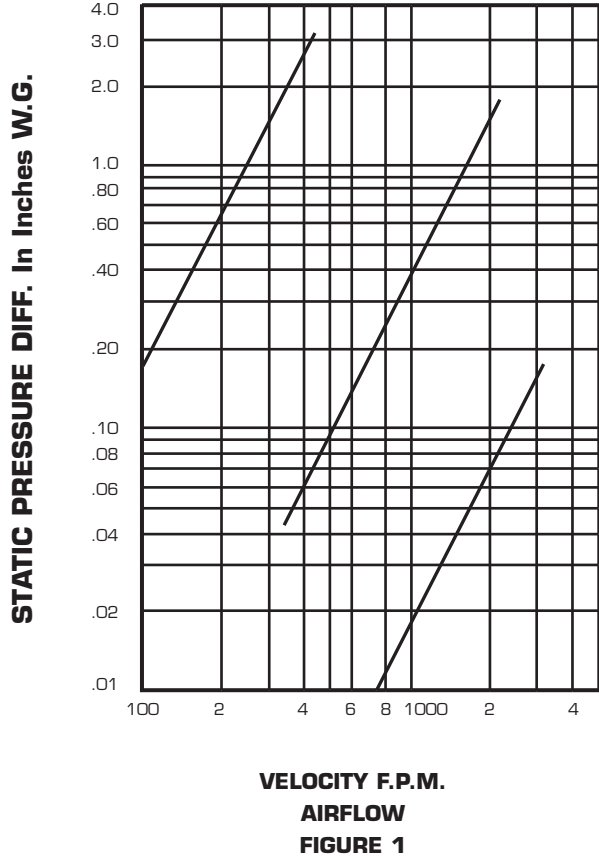

Example:

Determine the pressure drop for a 36"W x 24"H damper in the same size duct with 12,000 total CFM
12,000 CFM in a 36" x 24" duct is 2000 F.P.M.

$$\frac{12,000 \text{ CFM}}{6 \text{ sq. ft.}} = 2000 \text{ F.P.M.}$$

Figure 1 indicates that 2000 F.P.M. intersects curve C at 0.067 inches W.G.

To determine leakage at static pressure differentials greater than one (1") inch water gauge, multiply leakage at one inch from Table 1 by the correction factor found in Table 2

Example: Find leakage for a 48" W x 24" H damper at two (2") inches water gauge. From Table 1, 48 x 24 @ 1.0" S.P. = 5 CFM x 1.4 CORRECTION FACTOR = 7 CFM @ 2.0" WATER GAUGE.

		A WIDTH				
		12	24	36	48	60
B HEIGHT	12	1	1	1	2	2
	18	2	2	3	4	4
	24	3	3	4	5	6
	30	4	4	5	7	7
	36	5	6	7	8	8
	42	6	7	8	9	9
	48	7	8	9	11	11
	54	8	10	10	12	13
	60	9	11	11	14	15
	66	10	12	14	15	17
72	11	13	15	17	18	

TOTAL C.F.M. LEAKAGE

TABLE 1

Shown at one (1") inch static pressure W.G.
Max. of 5 in. lbs./ft.² holding torque.

**Correction Factor for Static Pressure
Greater than One Inch W.G.**

Install as marked and indicated				
S.P. in inches W.G.				
2	3	4	5	6
1.4	1.9	2.5	2.9	3.3

TABLE 2

Vent Products Co., Inc. recommends that dampers always be installed with the control linkage downstream, or on the air leaving side, and marks each Model 5900 damper shipped accordingly.

STANDARD NUMBER OF BLADES

*Blade Quantities shown include full and partial blades

"B" Height	11" and Under	12"-17"	18"-24"	25"-30"	31"-36"	37"-42"	43"-48"	49"-54"	55"-60"	61"-66"	66"-72"
*No. of Blades	1	2	3	4	5	6	7	8	9	10	11



Introducing Midco International's New Direct-Fired Gas Burners

The Blue Flame Series

Direct-Fired Gas Burners

Two Stage Combustion Technology

Higher Temperature Rise

Wider Operation Range

Shorter, More Stable Flame

and Lower Overall Emissions

Midco International is proud to introduce our new direct-fired gas burner, initiating a new era in direct-fired gas burner technology.

New Technology in Direct-Fired Gas Burners

Our innovative two stage combustion burner is not just a modification or improvement of the old, but a completely new approach to direct-fired combustion. The two-stage combustion improves control of the flame process, meets and exceeds the new ANSI Standards while outperforming the competition. By having two separate flames within the burner combustion zone, the flame is more stable, shorter and cleaner, permitting the reduction of emissions levels and allowing for higher temperature rise and higher tolerance to varying conditions when placed in the profile opening.

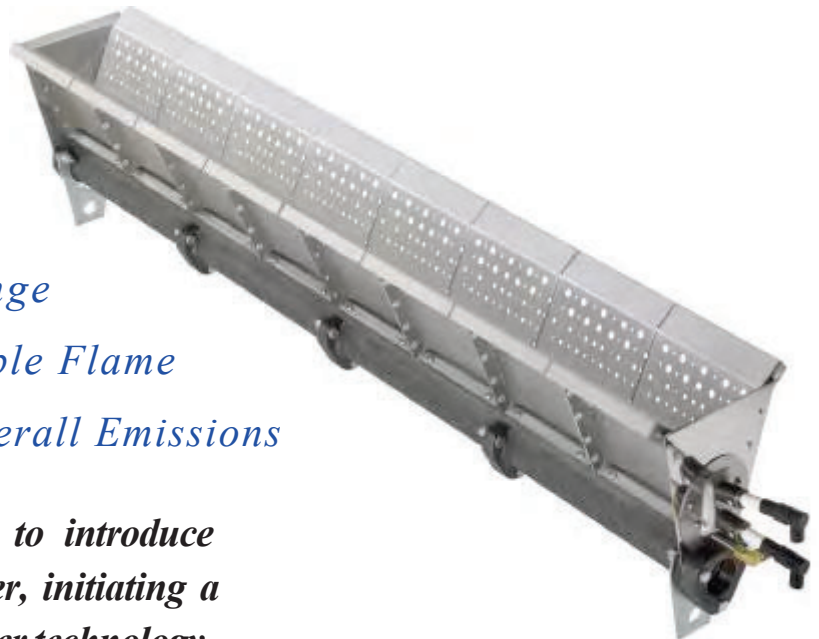

Two Stage Combustion

Provides Unsurpassed

Flame Stability and

Lower Emissions

Quality Designed for Proven Performance



The Blue Flame Series Specifications

*Firing Rate	Gas Inlet Pressure	Pressure Drop Across Burner	Pilot Capacity	Pilot Inlet Pressure	Burner Turn-down Ratio	Flame Length	Operating Velocities
Up to 750,000 Btu/hr/ft	NG 4.5 - 8" W.C. LP 1.7 - 3" W.C.	0.05 to 1.4" W.C.	12,000 Btu/hr	NG 5.0" W.C. LP 2.0" W.C.	30 to 1	10" full ** firing rate	800 fpm to 4000 fpm ***

* Firing rate is dependent on the pressure drop across the burner.
 ** Flame length depends on design pressure drop and is measured from the end of the baffle.
 *** For other operating velocities contact our Engineering Department.

Features and Benefits







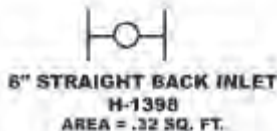
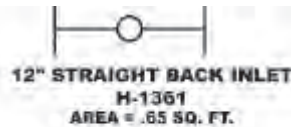
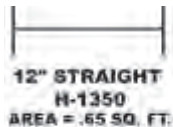

New Technology for

Direct-Fired Applications

Plus Flexibility in Configuration

Straight, elbow and tee sections easily configure to desired capacity maximizing efficiency for installation and performance. Burners may be ignited by proven pilot or direct spark. Pilots are available for flame rectification or ultraviolet detection. Hot surface ignition systems are also available. Contact the factory for specifications.



-  **Reduced NO₂ and CO Emissions:** Lower emissions levels that easily pass the new ANSI Z83.4 and Z83.18 standards.
-  **Higher Temperature Rise:** The two stage combustion process lowers NO₂ emissions which is the limiting factor in temperature rise.
-  **Increased Capacity:** Up to 750,000 BTU'S per foot. (Higher BTU levels can be achieved if ANSI Z83 Standards for CO and NO₂ emissions are not of a concern. Process heaters can fire up to 1,000,000 BTU'S a foot or more.)
-  **Increased Differential Pressure Drop and Higher Velocities:** HMA-2 burners can operate between 0.05" to 1.4" W.C. differential pressure range or in air velocity between 800 fpm to 4000 fpm.
-  **Flame Stability:** Two stage combustion provides better flame stability and emission control, allowing for a shorter flame and easier profile configuration.
-  **Reduced Inventory Costs:** Single burner casting can be fired with natural, propane or butane gas¹, reducing burner inventory.
-  **Reduced Shipping Costs:** A smaller, lighter casting than the competition's, can cut your freight costs up to 50%.
-  **Turndown:** 30-1 turndown can easily be achieved with proper modulation control and valves. (Higher turndown possible depending on equipment design.)

¹ Consult factory for applications using butane fuels.



Midco International Inc.
 4140 West Victoria Street
 Chicago, Illinois 60646
 tel 773.604.8700
 fax 773.604.4070
 web www.midco-intl.com
 email sales@midco-intl.com

Call our OEM sales team for more information (773-604-8700) or visit our website at www.midco-intl.com

INNOVATIVE SOLUTIONS

TRI  DIM
FILTER CORPORATION

TRI-DEK[®] 3/67
2-PLY PANEL AND LINK FILTERS

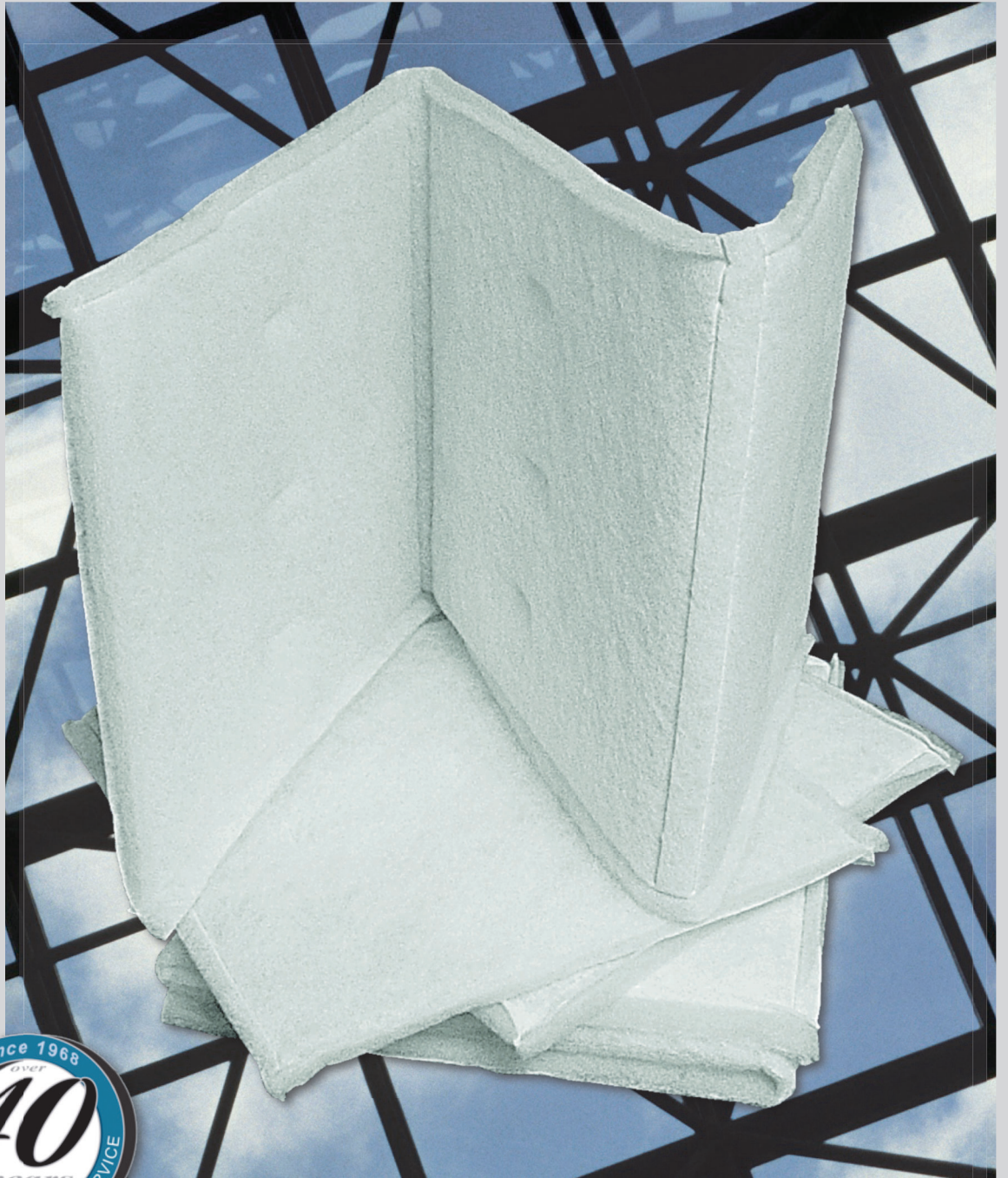

PRODUCT SPECIFICATIONS

MEDIA	Synthetic, dual denier
FRAME	Galvanized Wire
SEAL	Thermally Generated (<i>Standard sizes</i>)

RESISTANCE

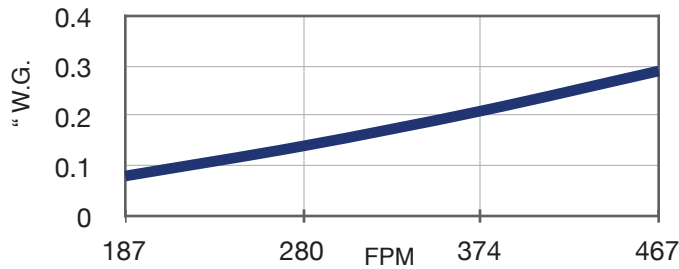

Initial Resistance vs. Airflow

Recommended Final Resistance = 1.0" WG

EFFICIENCY

Average Efficiency vs. Particle Size

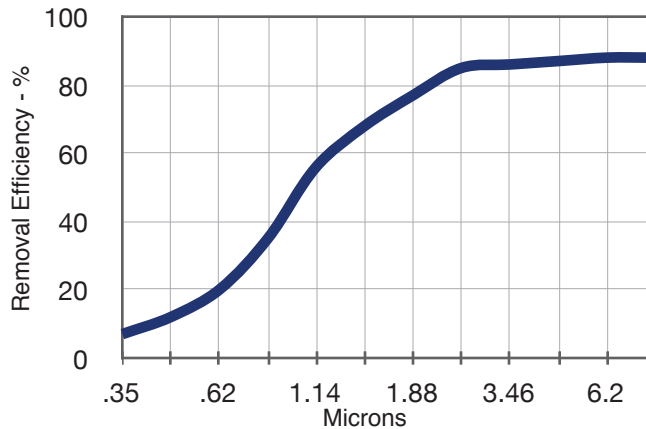

MEETS ANSI/UL-900 REQUIREMENTS



Tri-Dim Filter Corporation is committed to continual product development – all descriptions, specifications and performance data are subject to change without notice.

Tri-Dim products are manufactured to exacting criteria - there can be a $\pm 5\%$ variance in filter performance. Tri-Dim® and Tri-Dek® are Registered Trademarks of Tri-Dim Filter Corporation.



TRI-DIM FILTER CORPORATION
 P.O. BOX 466 • 93 INDUSTRIAL DRIVE
 LOUISA, VA 23093
 (540) 967-2600 • FAX: (540) 967-2835

EMAIL: info@tridim.com • Website: www.tridim.com
 TOLL FREE 1-800-458-9835



Local Representation:

Brochure # 400-1
 Revision: 07/2010



PLEASE RECYCLE - This paper may not be recyclable in your area if facilities do not exist. This brochure is printed on paper that is certified by the Sustainable Forestry Initiative (SFI) - for more information go to www.sfi-program.org.



NOMINAL SIZE (INCH)	ACTUAL SIZE		ORDERING REFERENCE	AIRFLOW CAPACITY (CFM)	MEDIA AREA (SQ FT)	WEIGHT (LBS)	NOMINAL SIZE (INCH)	ACTUAL SIZE		ORDERING REFERENCE	AIRFLOW CAPACITY (CFM)	MEDIA AREA (SQ FT)	WEIGHT (LBS)
	H	W						H	W				
20 X 16 X 2	19.50	15.50	405413001	1110	9.9	0.95	24 X 24 X 4	23.38	23.38	405414001	2000	28.6	2.76
20 X 20 X 2	19.50	19.50	405413002	1390	11.9	1.09	24 X 12 X 4	23.38	11.38	405414002	1000	13.9	1.46
25 X 20 X 2	24.50	19.50	405413003	1740	14.9	1.38	20 X 20 X 4	19.38	19.38	405414003	1390	18.9	1.92
25 X 16 X 2	24.50	15.50	405413004	1390	12.4	1.09	20 X 16 X 4	19.38	15.38	405414004	1110	15.7	1.53
24 X 24 X 2	23.38	23.38	405413005	2000	17.3	1.50	25 X 16 X 4	24.38	15.38	405414005	1390	19.7	2.00
24 X 12 X 2	23.38	11.38	405413006	1000	8.4	0.78	25 X 20 X 4	24.38	19.38	405414006	1740	23.6	2.38
24 X 20 X 2	23.38	19.50	405413007	1670	14.3	1.28	24 X 20 X 4	23.38	19.38	405414007	1670	22.7	2.29
24 X 18 X 2	23.50	17.50	405413008	1500	13.0	1.19	24 X 18 X 4	23.38	17.38	405414008	1500	20.2	2.09
25 X 18 X 2	24.50	17.50	405413009	1565	13.5	1.24	24 X 16 X 4	23.38	15.38	405414009	1330	18.7	1.84
20 X 14 X 2	19.50	13.50	405413010	975	8.3	0.72	INITIAL PRESSURE DROP (IN. W.G.)		0.35				
25 X 14 X 2	24.50	13.50	405413011	1220	10.4	0.95	FINAL PRESSURE DROP (IN. W.G.)		1.00				
24 X 16 X 2	23.50	15.50	405413012	1335	11.8	1.00							
25 X 25 X 2	24.50	24.50	405413013	2170	19.0	1.63							
20 X 12 X 2	19.50	11.50	405413014	830	7.3	0.63							
INITIAL PRESSURE DROP (IN. W.G.)			0.40										
FINAL PRESSURE DROP (IN. W.G.)			1.00										

- GENERAL NOTES:**
- MEDIUM EFFICIENCY, MERV 13 (80-85%) PANEL PLEATED DISPOSABLE. FILTER EFFICIENCY IS MINIMUM MERV RATING WHEN TESTED IN ACCORDANCE WITH ASHRAE 52.2-1999 AND MINIMUM DUST SPOT EFFICIENCY WHEN TESTED IN ACCORDANCE WITH ASHRAE 52.1-1992.
 - AVAILABLE SIZES (NOMINAL) AND EFFICIENCIES: SEE TABULATION BLOCK.
 - SEE CAMFIL FARR BULLETIN 1038-(LATEST REV) FOR OTHER FEATURES, CONSTRUCTION AND PERFORMANCE CHARACTERISTICS.
 - FILTER CLASSIFIED BY UNDERWRITERS LABORATORIES AS TO FLAMMABILITY ONLY U.L. CLASS 2.
 - PHYSICAL DATA (MATERIAL OF CONSTRUCTION):
 - FRAME: HIGH WET-STRENGTH BEVERAGE BOARD WITH DIAGONAL SUPPORT MEMBERS.
 - MEDIA: PLEATED, NON-WOVEN, REINFORCED SYNTHETIC MEDIA BLEND, BONDED TO A WELDED WIRE SUPPORT GRID.
 - ORDERING INSTRUCTIONS: SPECIFY BY NAME, MEDIA TYPE (EFFICIENCY), U.L. CLASS, NOMINAL SIZE (HxWxD) AND ORDERING REFERENCE.
 EXAMPLE:
 AP-THIRTEEN U.L. CLASS 2, SIZE 24x24x2, P/N 405413005
 AP-THIRTEEN U.L. CLASS 2, SIZE 24x18x4, P/N 405414008
 - FILTER THICKNESS:
 - NOMINAL = 1.75" ACTUAL
 - NOMINAL = 3.75" ACTUAL

- PERFORMANCE NOTES:**
- SEE TABULATION BLOCK FOR PRESSURE DROP (INITIAL AND FINAL) AND AIRFLOW CAPACITY. PERFORMANCE TOLERANCE IS IN ACCORDANCE WITH AIR STANDARD 850, SECTION 7.4.
 - CAMFIL FARR RECOMMENDS FILTER TO BE INSTALLED WITH THE PLEATS RUNNING PARALLEL TO HEIGHT DIMENSION.
 - OPERATING TEMPERATURE:
 - CONTINUOUS = 180°F
 - INTERMITTENT = 200°F
 - SEE RESISTANCE VERSUS AIRFLOW BULLETIN 1038-IRVA-(LATEST REV) FOR VARIOUS AIRFLOW CAPACITIES.

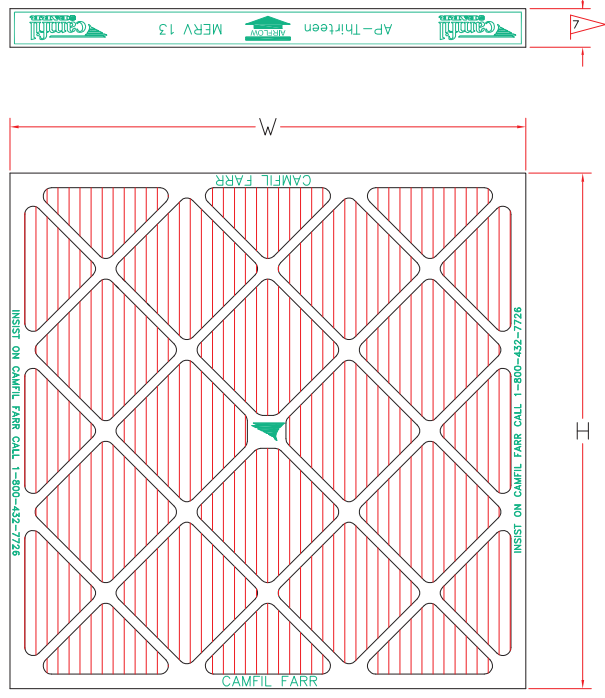

B	3/2/09	UPDATED DP	16055-L	JC	SM	SM
A	1/9/09	FIRST ISSUE	16055-J	SM	-	-
REV	DATE	DESCRIPTION	EW	DFT	CK	APP

camfil FARR
<http://www.camfilfarr.com>

DESCRIPTION
 AP-THIRTEEN CL2 FILTER
 MERV 13 (85%-90%)
 1.75 & 3.75 THICK

SHEET	DRAWING NUMBER	REV
1 OF 1	410724028	B



**LOW VOC
UNIVERSAL
PRIMERS**

1220 - 111 White

TAB 18 C IMA – 402

Type	Sheen	Spread Rate	Recommended Application	Thinner	Clean Up	DRY TIME		
						Tack Free	Re-coat	Cure
Modified Alkyd	Flat	Up to 500 Sq. Ft. Per Gallon	Spray	*	Xylene	15 Minutes	1 - 2 Hours	7 Days
PRODUCT NAME: 1220-111 White Low VOC Universal Primers		A versatile, heavy duty, rust inhibiting primer for application to a wide variety of substrates. It can be used as a tie coat over existing paint in sound condition and will accept topcoats of alkyd, alkyd urethane, urethane, and epoxy. Universal Primer is recommended for use as part of industrial maintenance coatings systems designed to resist moisture condensation, chemicals, extreme abrasion, corrosive elements and the assault of heavy duty cleansers. Not recommended for immersion surfaces.						
WHERE TO USE:		Ferrous Metal Universal Primer may be used to coat interior or exterior steel Galvanized surfaces, such as containers, tanks, structural members, Non-Ferrous Metal equipment, etc.						
Surface Preparation:		All surfaces must be sound, dry, clean, and free of oil, grease, dirt, mildew, form release agents, curing compounds, loose and flaking paint and other foreign substances. New Surfaces: Steel – For best results, abrasive blast to a commercial blast (SSPC-SP-6). For mild conditions, a hand or power tool cleaning (SSPC-SP-2) may be satisfactory, but performance is dependent on the degree of cleaning. Galvanized Metal: Solvent clean making sure all factory applied stabilizer or protective oil film is removed. Previously Painted Surfaces: Wash and rinse any areas that may have oil or grease residue. Dull glossy areas by light sanding. Remove sanding dust. Remove loose paint.						
Application:		Stir thoroughly, making sure no pigment remains on the bottom of the can, and the entire contents are fluid and free of lumps. Universal Primer is spray applied at up to 500 sq ft per gallon to achieve 1.5 – 2.0 dry mils. Surface texture and application method will effect actual yield. Small areas and touch-ups may be applied by brush. May be thinned up to 10% with Xylene for spray application. Caution should be taken when coating metal surfaces to avoid condensed moisture caused by temperatures at or below dew point. Apply when air and surface temperatures are between 45°F and 90°F.						
Heat Resistance: Dry Wet		250° Fahrenheit						
*Thinning:		Thinning not recommended.						
NOTE: Formulated without mercury or lead.								

Rev. 04/2015

Resin Type:	Epoxy Ester Modified Alkyd
Solids:	Weight – 72.8% Volume – 50.2%
Weight Per Gallon:	12.71 lbs
Viscosity:	85 – 90 Krebs Units
Flash Point:	46°F (Seta)
Sag Rating:	Pass 6 mils (Lenetta)
Recommended Film Thickness:	Wet – 3 to 4 mils Dry – 1.5 to 2 mils
Cautions:	<p style="text-align: center;">WARNING ! FLAMMABLE ! CONTAINS Petroleum Distillates</p> <p>Keep away from heat & flame. Vapor harmful. Causes eye irritation. To avoid breathing vapors or spray mist, open windows and doors or use other means to ensure fresh air entry during application and drying. If you experience eye watering, headaches or dizziness, increase fresh air or wear respiratory protection (NIOSH – Rule 42 CFA 84) or leave the area. Close container after each use. Avoid contact with skin.</p> <p>FIRST AID: If swallowed, do not induce vomiting. Call physician immediately.</p> <p style="text-align: center;">Use with adequate ventilation.</p> <p>NOTICE: Reports have associated repeated and prolonged occupational over-exposure to solvents with permanent brain & nervous system damage. Intentional misuse by deliberately concentrating and inhaling the contents may be harmful or fatal.</p> <p style="text-align: center;">Obtain and read the material safety data sheet before using. KEEP OUT OF REACH OF CHILDREN. INTENDED FOR PROFESSIONAL USE ONLY.</p>
VOC – VOS Statement:	This product contains a maximum of 420 grams of VOC/VOS per liter of coating. (3.5 lbs. per gallon)

Rev. 04/2015

IMA 402





Technical Data Sheet

Product #: 196-4642
Product Name: Quick Dry Sain Enamel Basalt Gray

Description: A satin finish, solventborne, acrylic modified alkyd enamel designed with exceptionally fast air-drying characteristics and very low VOC for a solvent thinned coating. Acrylic modification enhances the durability and performance on interior and exterior metal surfaces. Outstanding corrosion and weather resistance. Recoatable in two hours under normal conditions. Ideal for OEM, field, or re-paint applications on steel and aluminum.

Properties

Physical

Viscosity: 40-50" #2 Zahn
 Weight/Gallon: 9.9 +/- 0.25
 Gloss: 30-40
 Weight Solids: 56% +/- 2%
 Volume Solids: 42% +/- 2%

VOC (theo.): Less than 3.5 Lbs./Gal.
 Less than 420 grams/Liter

Flash Point: (Setaflash) 45°F

Storage: 1 year unopened @ 77° F

Application

Viscosity: As is
 Reduction: None
 Application Method: Airless spray/HVLP spray
 Clean-up: Xylene

Coverage: (sq. ft./Gal.) 450-550 (Excluding spray loss)
 Wet Film Thickness: 2.5-3.1 mils
 Dry Film Thickness: 1.2-1.5 mils

Dry-To-Touch: 15-20 minutes
 Dry to Recoat: 2-8 Hours / After 48 Hours
 Dry Hard: 18-24 Hours

Note: Drying times are at 77° F and 50% Relative Humidity. Cool temperatures, high humidity, heavy film thicknesses or poor ventilation will extend drying times.

Notes: Formulated without lead, chrome, or mercury. May be brush or roller applied to small areas. All surfaces to be painted must be clean, dry, and free from dirt, grease, oil, rust, mill scale, welding dust, and any other foreign matter.

The information and data given herein are based upon tests and reports considered reliable and believed to be accurate. However, due to circumstances beyond our control including but not limited to surface preparation, application technique, substrate and curing conditions, no guarantee of duplicate performance, expressed or implied, is made.

3/15/2017

ROXUL Safe®

Fire Stopping Insulation

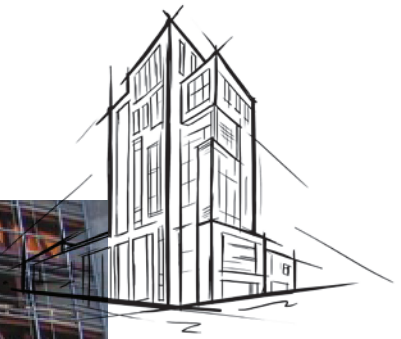

Fire-stopping Material

ROXUL Safe® is always used in conjunction with a fire sealant to prevent passage of fire and smoke from one area to the next.

ROCKWOOL ROXUL Safe® is a lightweight, semi-rigid stone wool insulation that provides fire-stopping and acoustical properties. It is designed to fill perimeter gaps between concrete floor slabs and exterior wall systems, between firewalls and ceiling slabs, and around conduit pipes and duct openings through walls and floor slabs.

It is non-combustible and fire resistant, and will not develop toxic smoke or promote flame spread, even when exposed directly to a fire. When ROXUL Safe® is used with ROCKWOOL Curtainrock®, it provides a comprehensive fire-stopping system that has been UL/ULC/Intertek tested and approved for perimeter fire containment systems.

Fire stopping insulation should be installed per the listed assembly with compression fitting requirements to form a tight seal between the floor line and exterior curtain wall assembly in perimeter installations so that flame and hot gases cannot pass through the joint. For through penetrations and construction joints, ROXUL Safe® should be cut as needed for compression fit leaving no voids.

Moisture resistant, non-corrosive and mildew-resistant, ROXUL Safe® also helps to reduce noise transmission into and out of the building for improved occupant comfort.

Learn more at rockwool.com



ROCKWOOL ROXUL Safe® is semi-rigid, mineral wool batt insulation approved for use in fire rated joints, through penetrations and perimeter fire containment systems.

	Performance	Test Standard
Compliance	Mineral Fiber Block and Board Thermal Insulation - Type IVA Compliant MEA Approval, New York City Approval	ASTM C612 339-97-M
Reaction to Fire	Flame spread index = 0; Smoke developed index = 0 Flame spread index = 0; Smoke developed index = 0 Determination of Non Combustibility of Building Materials - Non Combustible Test for Non-Combustibility - Non Combustible Fire Tests of Firestop Systems Fire Tests of Penetration Firestop Systems Tests for Fire Resistance of Building Joint Systems Perimeter Fire Barrier Systems Smoulder Resistance - 0.01% Consult UL, ULC and Intertek Directories for fire rated designs	ASTM E84 (UL 723) CAN/ULC S102 CAN/ULC S114 ASTM E136 CAN/ULC S115 ASTM E814 (UL 1479) UL 2079 ASTM E2307/E119 CAN/ULC S129
Density	Actual Density - 4.0 lbs/ft³ (64 kg/m³)	ASTM C303
Corrosion Resistance	Stress Corrosion Cracking Tendency of Austenitic Stainless Steel - Passed Corrosion of Steel - Passed	ASTM C795 ASTM C665
Reaction to Moisture	Moisture Sorption by weight - 0.04% Determination of Fungi Resistance - Passed	ASTM C1104 ASTM C1338
Thickness Dimensions	Product is available in 1.5", 2", 3", 4", 5" and 6" (38.1 mm, 50.8 mm, 76.2 mm, 101.6 mm, 127 mm and 152.4 mm), 24" x 48" (610 mm x 1219 mm)	



For more information regarding the certifications and listings of our stone wool insulation products, please visit:

rockwool.com/north-america/about-us/sustainability/certifications-and-listings/

Issued 07-22
Supersedes 03-22

NOTE: *Master Format 1995 Edition **Master Format 2004 Edition. As ROCKWOOL has no control over installation design and workmanship, accessory materials or application conditions, ROCKWOOL does not warranty the performance or results of any installation containing ROCKWOOL's products. ROCKWOOL's overall liability and the remedies available are limited by the general terms and conditions of sale. This warranty is in lieu of all other warranties and conditions expressed or implied, including the warranties of merchantability and fitness for a particular purpose.

Description	Part #	Most Used
High gas pressure sw	P-001827 899-002-42	
Low gas pressure sw	P-001779 899-001-13	
High temperature limit sw	07071	
Airflow switch	28892	*
Fireeye Flame Relay	P-000528	
Igniter I-31	07635	*
Igniter I-31-1	07640	*
Spark rod midco	14123204	*
Flame rod midco	P-000640	*
Ignition transformer	28386	*
Gas valve actuator	07160	
Pilot regulator	28311	*
Pilot valve solenoid	07522	*
75VA transformer	803-001-63	
MRV coil	07467	
Ignition wire per ft	18691	*
Ignition wire end	18527	*
Burner damper actuator 24vac	22970	
Burner damper actuator 120vac	01692	
Relay 120vac	08074	
Relay 24vac	08077	
Relay base	08073	
Relay retaining clip	08072	
Input relay - yellow	28312	*
Output relay - OA5S	28313	*
Output relay RO5S	28314	*
Output relay - OM5SR	28315	*

Spare Parts for optional Upgrades

Discharge air sensor ics-2	18945	
Room sensor ics-2	18780	
Room sensor IP/ICS IV	12103	
Discharge air sensor IP/ICS IV	02111	
Flame relay	807-000-25	
Flame relay base	807-000-00	
UV scanner	07060	*
Signal Conditioner	P-000840	

Mechanical Specifications

GENERAL

A. Provide self contained industrial air handlers with gas-fired heating and ventilating sections, designed and manufactured for indoor or outdoor installation. Units shall be packaged air handlers which include casing, modulating burner, non-overloading fan, mixing chamber (AM and VAV Models only), positive position modulating return air dampers (AM and VAV Models only), and automated DDC-based controls for temperature control, pressure control and system monitoring.

SECTION INCLUDES

- A. Direct-fired air handler
- B. Controls

REFERENCES

A. American National Standards Institute (ANSI)/Canadian Standards Association (CSA): Establishes requirements applicable to certifying direct gas-fired heaters.

- 1. MUA Model: Standard Z83.4: Non-Recirculating Direct Gas-Fired Industrial Air Heaters
- 2. AM, VAV, FR Models: Standard Z83.18: Recirculating Direct Gas-Fired Industrial Air Heaters

B. American Society for Testing Materials (ASTM): Establishes standards for materials, products, systems and services.

- 1. Standard A653/653M: Standard Specification for Steel Sheet, Zinc-Coated (Galvanized) or Zinc-Iron Alloy Coated (Galvannealed) by the Hot Dip Process

C. ETL Testing Laboratories, Inc. (ETL):
Nationally recognized testing laboratory certifies code conformance.

- 1. Requirements applicable to product labeling and listing in the Directory of ETL Listed Products.

D. Factory Mutual Insurance (FM): Ensure compliance of gas manifold to owner's insurance carrier.

E. XL Insurance (formerly IRI): Ensure compliance of gas manifold to owner's insurance carrier.

F. National Electrical Manufacturers Association (NEMA):

Establishes technical standards for the electroindustry.

- 1. Standard 250: Enclosures for Electrical Equipment (1000 V Maximum)

G. National Fire Protection Association (NFPA): Establishes fire prevention standards.

- 1. Article 54: National Fuel Gas Code (latest edition)
- 2. Article 70: National Electric Code (latest edition)
- 3. Article 90A: Installation of Air Conditioning and Ventilating Systems

H. National Roofing Contractors Association (NRCA): Establishes best practices for the roofing industry.

- 1. The NRCA Roofing and Waterproofing Manual, Second Edition

I. Occupational Safety and Health Administration (OSHA): Enforces air quality standards and safety in the workplace.

J. Underwriters Laboratories, Inc. (UL): Nationally recognized testing laboratory certifies code conformance, product labeling and listing.

- 1. Standard UL916: Energy Management Equipment
- 2. Standard UL873: Temperature Indicating & Regulating Equipment

SUBMITTALS FOR REVIEW

A. Product Data: Provide data with dimensions, weights, duct and service connections, accessories, controls, electrical nameplate data and wiring diagrams.

B. Submittal Drawings: Indicate dimensions, weights, duct and service connections, accessories, controls, electrical nameplate data and wiring diagrams.

SUBMITTALS FOR INFORMATION

A. Manufacturer's Instructions: Indicate rigging, assembly and installation instructions.

SUBMITTALS AT PROJECT CLOSEOUT

A. Project Record Documents: Record actual locations of remote sensors, control panels and other components.

B. Operation and Maintenance Data: Include manufacturer's Installation, Operation and Service Manual.

C. Warranty: Submit manufacturer's warranty and ensure forms have been filled out in owner's name and registered with the manufacturer.

QUALITY ASSURANCE

A. Manufacturer Qualifications: Company specializing in manufacturing the products specified in this section (building pressure controlling, modulating direct-fired air handler) with a minimum of 25 years documented experience. Equipment shall be the standard product of the manufacturer and shall have complete cataloged data.

B. Installer Qualifications: All installation and service of air handlers must be performed by a contractor qualified in the installation and service of said products with proof of a minimum of five years documented experience.

C. Factory Testing: Each air handler shall be factory-tested. Testing shall consist of checking all circuits for continuity, operability of all valves, control motors, fan speed, linkages, switches and burner. Each air handler shall be test-fired for low and high fire conditions. See "Fan and Motor" for additional fan testing requirements.

REGULATORY REQUIREMENTS

A. Conform to ANSI Standards Z83.18 or Z83.4 (latest revision) and provide evidence that the air handler and its control system have been found in compliance as a system with these standards by a nationally recognized testing laboratory.

B. Conform to NFPA 90A.

C. Conform to the National Fuel Gas Code (NFPA 54 / ANSI Z223.1).

D. Conform to required or specified insurance specifications (FM, XL Insurance (formerly know as IRI), etc) for the gas manifold construction.

WARRANTY

The product shall have a manufacturer's limited warranty of at least 24 months, subject to the manufacturer's standard warranty limitations.

MANUFACTURERS

A. RAPID® 4000-Series, incorporating one of the following outdoor air control schemes, as specified herein or shown on the plans:

- 20% - 100% outdoor air (Air Management [AM] Model)
- 100% outdoor air (Make-up Air [MUA] Model)
- 20% outdoor air (Fixed Recirculation [FR] Model)
- 20% - 100% variable air volume (VAV Model)

MANUFACTURED UNITS

A. Unit: Depending upon style chosen shall be [Constant] [variable] volume [outdoor] [indoor] air handler.

FABRICATION

A. Casing and Components: 16-gauge minimum aluminized steel enclosure, welded to a steel angle frame. The panels for outdoor units shall be stitch welded and caulked at the seams to provide a watertight enclosure. For static pressure applications above 5" wc, gauge thickness is increased to between 14ga-10ga.

B. Fan Support: The fan and bearings shall be supported by a reinforced steel framework independent of the cabinet.

C. Access Doors: Neoprene-gasketed doors shall be provided to allow easy service of all critical components, controls and fan.

D. Outdoor Installation: Units installed outdoors shall utilize weatherproof construction with intake hood or plenum.

E. Lifting Points: Internal members shall be properly sized to allow rigging and handling of the unit from the top.

F. Finish: All cabinet surfaces are to be thoroughly washed using aero-green high pressure cleaner/degreaser. Cleaning agent is applied using a high pressure, high temperature, power washer. After a thorough cleaning, surfaces are rinsed using a high pressure, high temperature, power washer. Excess water remaining inside equipment shall be removed utilizing a vacuum. Each piece of equipment is then placed inside a dry-off oven. Desired dry time is a minimum of 45-minutes at 125 °F, or until all residual trapped water within metal joints and structural members is eliminated. Each exterior surface and any uncoated interior surfaces accept a prime coat of solvent borne industrial modified alkyd primer. Once cured, a high gloss solvent borne acrylic modified alkyd enamel is applied. After manufacturing process is completed, a final coat is applied to ensure all surfaces and fasteners are corrosion resistant.

G. Observation Port: Provide on burner section for observing main and pilot flames.

H. Mixing Section (Optional): The air handler shall incorporate a separate compartment containing two 16-gauge galvanized dampers interlinked to work opposite each other. Each damper shall control up to 80% of the total air handler fan volume of either outdoor air or the return air from the building. These dampers shall be controlled so as to provide an outdoor air turndown ratio of 5:1 based on the fan total flow rate. For cooling applications, up to 100% return air is available.

BURNER AND GAS TRAIN

A. Burner: Type [NP-LE] [HMA-2], specially designed to burn natural or LPG at or below the non-contaminating levels required by ANSI and OSHA. The burner shall have an aluminum manifold and heat resistant Type 430 stainless steel burner plates. The burner shall have a nominal 30:1 turndown ratio and be designed for 100% combustion efficiency for the life of the equipment.

B. Burner Profile: The outdoor air velocity across the burner shall be controlled by fixed burner profile plates. The design of the unit profile plates shall maintain manufacturer's specified air velocity over the burner during operation. No air from the occupied space shall be allowed to recirculate across the burner at any time.

C. Burner Assembly / Gas Train: The burner assembly and fuel piping arrangement shall include automatic ignition controls, flame rod (optional-ultraviolet (UV) scanner) flame failure system, 5 psig pressure regulator, fully modulating gas control valve, primary and secondary automatic shutoff valves and manual shutoff valve. Pilot gas controls shall include a pilot regulator, normally closed solenoid shutoff valve, needle valve, high gas pressure switch and manual shutoff valve. Gas train shall be sized to provide full unit capacity at specified inlet pressure to the gas train. Provide and install a supplementary pressure regulator at each unit as necessary to maintain unit inlet pressure at less than 5 psig.

D. Pilot: Electric spark ignition through a high voltage ignition transformer.

FANS AND MOTORS

Fan: Single width, single inlet (SWSI), backward-incline airfoil fan, v-belt driven for specified air capacity with an efficient silent plenum. A precision inlet cone shall be provided for streamlined airflow into the fan wheel to insure full and even loading of the fan blades. Blower wheel, shaft and drive sheaves shall be both statically and dynamically balanced. Each fan and drive combination shall be dynamically balanced during testing at the factory to .1" per second or less equivalent displacement.

B. Drive: The fan shaft shall be connected to the motor by a multiple V-belt drive designed to handle 50% more power than the motor name plate capacity. The fan wheel and bearings shall be supported by reinforced structural steel framework independent of the unit housing. The motor sheave shall be a fixed design for motors larger than 10 HP.

C. Fan Bearings: Self-aligning, pillow block or flange type and shall have (for external static pressure less than 1" wc [2.5 mbar]) an American Bearing Manufacturers Association (ABMA) L10 rated life of 100,000 hours and be equipped with optional extended lubrication lines. Extended lubrication lines shall be terminated at the unit's outer skin so that all lubrication can be performed without shutting down the system.

D. Motor: The motor shall be a premium efficiency design with minimum service factor of 1.15, 1750 rpm, standard NEMA frame and mounted on an adjustable slide base.

E. Sound Power: The fan sound power shall not exceed 75 dBA at a distance of 10' (304 cm) from the air handler discharge opening.

CONTROL SYSTEM

A. Factory Testing: The complete control system and all burner and gas manifold functions shall be factory tested for proper operation and to simplify field commissioning.

B. Control Enclosure: The unit control enclosure shall be constructed to NEMA 3R specifications with a hinged door. The control enclosure shall contain the gas train and all principal electrical components, such as motor, motor starter, fused disconnect switch, 120 V and 24 V transformers, control circuit fuses, control relay(s), [circuit check lights], [DDC microprocessor, I/O modules], [pressure transducer], flame relay and full number-coded touch-safe terminal strip.

C. Flame Relay: The air handler control panel shall have a burner flame relay to lock out the flame in abnormal conditions.

D. Safety Controls:

1. High Gas Pressure Switch: The high gas pressure switch, located on the burner end of the manifold, shall turn the burner off when the gas pressure is above its setpoint. The maximum gas pressure shall be selectable between 3" wc [7.5 mbar] and 21" wc [52.3 mbar].

2. Low Gas Pressure Switch: The low gas pressure switch, located on the inlet end of the manifold, shall turn the burner off when the gas pressure is below its setpoint. The minimum gas pressure shall be set at 3" wc.

3. Air Flow Switches: The air flow switches measure air pressure differential across the burner to assure proper air flow during burner operation and prior to ignition. It shall be factory set at 0.2" wc [4 mbar] for the low setting and 1.35" wc [3.4 mbar] for the high setting. Pressure switches shall not be field adjustable.

4. High Temperature Limit Switch: A manual reset high temperature switch shall turn the burner off when air is discharged above its set point. The high temperature limit switch shall be factory set at 150 °F (65.6 °C).

PERFORMANCE

A. See Schedule on plans.

INSTALLATION

A. The unit shall be started per the instructions in the Installation, Operation, and Service Manual by the Installing contractor. A factory provided field start-up form shall be filled out by the contractor and mailed to the manufacturer. The start-up sheet shall include, but not be limited to:

- Verification of proper supply power and fuel.
- Verification that electrical terminals are secure.
- Proper air flow balance.
- Verification of combustion efficiency and proper burner adjustments.
- Testing of all safety and operating controls.
- Setting of burner fire.

B. One copy of the Installation, Operation, and Service Manual shall be enclosed in the unit control panel. The manual shall consist of recommended

installation procedures and guidelines, inspection, initial start-up, operating, maintenance and troubleshooting sections.

SCHEDULES

A. See plans.

Style : AM

The control scheme shall be variable outdoor air and return air ratio within the range of 100% outdoor air to 0% return air to 20% outdoor air/80% return air with constant discharge air volume (Air Management [AM] Style).

Paint : Enamel Rapid Blue (RAL-7012)

Exterior surfaces of cabinet shall be finished with blue enamel paint.

Indoor/Outdoor : Outdoor

The unit shall utilize weatherproof construction.

Motor Options : ODP, premium efficiency

Supply fan motor, of stated HP, shall be ODP (open drip proof) design.

Fuel Type : Natural gas

Air handler shall be designed to provide specified heating performance using natural gas as its fuel source.

Manifold Size : 1.5" w/ regulator

Gas manifold shall include a high gas pressure regulator suitable for use at the specified fuel supply gas pressure.

Gas Train Options : FM Compliant

Gas train shall be constructed in compliance with the latest FM standard / requirements

Insulation : Double wall Unit and Accessory Sections

Double-Wall Construction: The unit walls and ceiling shall be covered with 2", 4 lb/ft³ density, mineral wool insulation. This insulation shall then be covered by an exterior skin with a minimum thickness of 20 gauge.

Filter Section : Filter mix box, right return

Filter Mix Box: The filter mix box shall include a filtration section downstream of both the outdoor air and return air streams. Design shall prevent the mixing of combustion air and return air therefore preventing any return air from passing across the burner.

Mounting Option : Curb supplied by Rapid™ / shipped ahead

Roof Curb: The roof curb shall be 19" (48.2 cm) fullperimeter, formed of minimum 16-gauge galvanized steel as required to support the unit. Curb is provided knocked down for field assembly. If required, insulation and / wood nailer are provided by installer.

Optional Dampers : Motorized premium low leak inlet damper only

Air handler to be equipped with a factory installed two position motorized inlet damper (equipped with proving switch) mounted in the inlet air opening of the unit. Damper blades to be equipped with jamb and edge seals to minimize leakage.

Exhaust Mode : With hood LE

Air handler to be equipped with two openings on supply fan section. Each opening shall include mounted dampers of the low leak / high velocity design, the normal supply opening damper shall be normally open and the exhaust opening damper shall be normally closed. When activated in exhaust mode, the air handler will close the OA and normal supply air dampers, while simultaneously opening the return air and exhaust dampers. These actions stop the air handler from supplying outdoor ventilation air to the space and converting itself into a 100% exhausting fan A weather hood is to be provided for protecting the exhaust damper / actuator(s) from the elements.

Controller : ICS IV

Air handler's controls shall be DDC micro-processor based.

Controls Remote : ICS IV/InfinityPro Equipment Touch Remote

Air handler controls shall include a NEMA1 rated, Touch Screen enabled remote machine operating interface. Touch screen shall allow for monitoring / programming of all air handler functions.

Other Option : Extended grease lines (supply fan)

Grease fittings for the fan bearings shall be extended to the exterior of the unit casing to allow for lubrication without shutting down the air handler.

Other Option : Filters Polylink - One Set

Provide (1) set of 1" thick, treated on leaving side, MERV 7 linked polyester media filters for use in outdoor air or filter mixbox sections.

Other Option : Filters Polylink - Two Sets

Provide (2) set of 1" thick, treated on leaving side, MERV 7 linked polyester media filters for use in outdoor air or filter mixbox sections.

Controls Options : Filter status indicator

A clogged filter light on remote panel will illuminate to indicate a "clogged" status. The factory installed differential pressure sensing switch is adjustable to allow for variable levels of contaminant buildup before giving the "clogged" signal.

Controls Options : GFCI 120V Duplex outlet + control cabinet light (powered by Rapid)

Air handler shall be equipped with a factory mounted ground fault interruptive convenience outlet and incandescent light mounted inside the air handler main electrical enclosure. These items are to be powered by a separate 750VA transformer that is powered from the line side of the air handler disconnect

Controls Options : Smoke detector (shipped loose for field installation)

Air handler shall be supplied with an Ionization type detector to be installed, within the conditioned space, by others. Detection of smoke will shut down the Air Handler and close the outdoor air dampers.

Discharge Accessories : 3- Way Discharge head horizontal and vertical blades

The manufacturer shall provide a 1 way, discharge head as detailed on the plans. The head shall include adjustable, locking, double deflection blades for control of discharge airflow direction both horizontally and vertically.

Terms of Use

These Terms of Use are a contract between you and Rapid Engineering. By using any electronic media we produce for equipment sizing, design, selection and pricing ("Electronic Media"), you are agreeing to be bound by the following terms and conditions ("Terms of Use"). If you do not agree to these Terms of Use, do not use any Electronic Media we produce; instead, promptly return it to Rapid Engineering. This contract is effective until terminated by Rapid Engineering. This contract will be terminated immediately and without notice in the event that you fail to comply with any term or condition hereof.

1. Ownership of Content.

The Electronic Media is owned by Rapid Engineering. The media can be in any form such as an actual CD that has to be installed or electronic file that has to be downloaded. The visual interfaces, graphics, design, compilation, information, computer code (including source code or object code), products, software, services, and all other elements of the Electronic Media (the "Materials") are protected by United States copyright, trade dress, patent, and trademark laws, international conventions, and all other relevant intellectual property and proprietary rights, and applicable laws. All Materials contained on the Electronic Media are the property of Rapid Engineering or its subsidiaries or affiliated companies and/or third-party licensors. All trademarks, logos and service marks displayed on the Electronic Media, whether registered or unregistered, are owned exclusively by Rapid Engineering or its affiliates and/or other third parties. Nothing contained in these Terms of Use, nor your use of the Materials, shall be construed as granting you any license or right in or to any trademark, logo, or service mark. Rapid Engineering reserves all rights not expressly granted in this Terms of Use.

2. License

Rapid Engineering hereby grants you a nontransferable, nonexclusive license to use the Materials contained on the Electronic Media solely for your information and own personal, noncommercial use, to be used with a single computer at a single location. You may download and/or print a single copy of any of the Materials contained herein for your personal use; however, you shall not otherwise reproduce, display, publish, distribute, sell, license, or modify the Materials or incorporate the Materials into other documents, Electronic Media, or publications. This license is not a sale of the electronic Media or any copy thereof. Rapid Engineering retains the title and ownership of the Electronic Media and all copies, regardless of the form or media on or in which the original or any copy may exist. You may not copy, encourage or allow copying of the Electronic Media, except when you make a single copy for archival purposes only. You may be held legally responsible for any copyright infringement which is caused or encouraged by your failure to abide by this Terms of Use. You may not transfer, convey, rent, sublicense, or otherwise distribute the Electronic Media or accompanying documentation, or any rights therein to any person or entity. Any attempt to so distribute the Electronic Media or accompanying documentation shall be void.

3. Modification of these Terms of Use; Termination.

Rapid Engineering reserves the right, at our discretion, to change, modify, add, or remove portions of these Terms of Use at any time.

4. Disclaimer of Warranties

The Electronic Media and Materials may contain inaccuracies and/or typographical errors. The Electronic Media and Materials are provided to you on an "AS IS" basis. Rapid Engineering DISCLAIMS ANY AND ALL WARRANTIES EXPRESSED, STATUTORY OR IMPLIED WITH RESPECT TO THE ELECTRONIC MEDIA OR THE MATERIALS, INCLUDING BUT NOT LIMITED TO ANY IMPLIED WARRANTIES OF MERCHANTABILITY, NON-INFRINGEMENT OR THIRD PARTY RIGHTS AND FITNESS FOR A PARTICULAR PURPOSE.

5. Limitation of Liability and Damages

Rapid Engineering does not warrant, guarantee or make any representations regarding the use or the results of the Electronic Media in terms of its correctness, accuracy, performance, reliability or otherwise. The entire risk as to the results and performance of the Electronic Media is assumed by you. This Electronic Media is merely a tool to aid you, the results of which should be checked against your own calculations. Rapid Engineering makes no warranties, express or implied including without limitation the implied warranties of merchantability and fitness for a particular purpose. TO THE FULLEST EXTENT ALLOWED BY APPLICABLE LAW, Rapid Engineering HEREBY DISCLAIMS, AND IN NO EVENT SHALL Rapid Engineering OR ANY PARTY INVOLVED IN CREATING OR PRODUCING THE ELECTRONIC MEDIA, BE LIABLE FOR ANY DIRECT, INDIRECT OR CONSEQUENTIAL DAMAGES RESULTING FROM LOSS RELATED TO THE USE OF THE ELECTRONIC MEDIA OR ANY MATERIALS, WHETHER IN AN ACTION OF CONTRACT, NEGLIGENCE, OR OTHER TORTUOUS ACTION, EVEN IF Rapid Engineering HAS BEEN ADVISED OF THE POSSIBILITY OF SUCH DAMAGES, INCLUDING DAMAGES FOR LOSS OF BUSINESS PROFITS, BUSINESS INTERRUPTIONS, LOSS OF BUSINESS INFORMATION AND THE LIKE, ARISING OUT OF THE USE OR LIABILITY TO USE THE ELECTRONIC MEDIA. FURTHERMORE, Rapid Engineering SHALL NOT BE LIABLE FOR ANY DAMAGES TO YOUR PROPERTY OR LOSS OF DATA THAT RESULTS FROM THE DOWNLOAD OR USE OF THE MATERIALS.

6. Indemnification

You agree to indemnify, save, and hold Rapid Engineering, its affiliated companies, contractors, employees, agents and its third-party suppliers, licensors, and partners harmless from any claims, losses, damages, liabilities, including legal fees and expenses, arising out of your use or misuse of the ELECTRONIC MEDIA, any violation by you of these Terms of Use, or any breach of the representations, warranties, and covenants made by you herein. Rapid Engineering reserves the right, at your expense, to assume the exclusive defense and control of any matter for which you are required to indemnify Rapid Engineering, and you agree to cooperate with Rapid Engineering's defense of these claims. Rapid Engineering will use reasonable efforts to notify you of any such claim, action, or proceeding upon becoming aware of it.

7. Miscellaneous

These Terms of Use constitute the entire agreement between you and Rapid Engineering and govern your use of the ELECTRONIC MEDIA, superseding any prior agreements between you and Rapid Engineering (including, but not limited to, any prior versions of the Terms of Use) and any prior representations by Rapid Engineering. These Terms of Use shall be governed by and construed in accordance with the laws of the State of New York, without regard to conflicts of law principles. The failure of Rapid Engineering to exercise or enforce any right or provision of the Terms of Use shall not constitute a waiver of such right or provision. If any provision of the Terms of Use is found by a court of competent jurisdiction to be invalid, the parties nevertheless agree that the court should endeavor to give effect to the parties' intentions as reflected in the provision, and the other provisions of the Terms of Use remain in full force and effect. You agree that regardless of any statute or law to the contrary, any claim or cause of action brought against Rapid Engineering and its subsidiaries, affiliates, officers, agents, co-branders or other partners and employees, arising out of or related to use of the ELECTRONIC MEDIA or the Terms of Use must be filed within one (1) year after such claim or cause of action arose or be forever barred. The section titles in the Terms of Use are for convenience only and have no legal or contractual effect.

8. In the Event of Merger or Sale

In the event that Rapid Engineering is acquired by or merged with a third-party entity, we reserve the right, in any of these circumstances, to transfer or assign the information that we have collected from Users as part of such merger, acquisition, sale, or other change of control.

9. Rapid Engineering Contact Information:

Please contact Rapid Engineering with any questions or comments about this Terms of Use at: "Contact Us" <http://www.Rapid Engineering-hvac.com/>.

