

FOR QUESTIONS, CALL THE
Highwoods Group
REGION 40
PHONE: (919) 875-0420
EMAIL: reg40@captiveaire.com

PATENT NUMBERS
EXHAUST HOODS ND-2/BD-2/SND-2 (CANADA) - CA PATENT 2520435 C.

HOOD INFORMATION - JOB#6029518

HOOD NO	TAG	MODEL	MANUFACTURER	LENGTH	MAX COOKING TEMP	TYPE	APPLIANCE DUTY	DESIGN CFM/FT	TOTAL EXH CFM	EXHAUST PLENUM RISER(S)				HOOD CONSTRUCTION	HOOD CONFIG			
										WIDTH	LENG	HEIGHT	DIA		CFM	VEL	SP	END TO END
1		5424 ND-2	CAPTIVEAIRE	9' 4"	600 DEG	I	HEAVY	204	1900	10"	18"	4"	1900	1520	-0.818"	430 SS WHERE EXPOSED	ALONE	ALONE

HOOD INFORMATION

HOOD NO	TAG	FILTER(S)				LIGHT(S)				UTILITY CABINET(S)				FIRE SYSTEM	HOOD HANGING WEIGHT		
		TYPE	QTY	HEIGHT	LENGTH	EFFICIENCY @ 7 MICRONS	QTY	TYPE	WIRE GUARD	LOCATION	SIZE	TYPE	SIZE			ELECTRICAL MODEL #	SWITCHES QUANTITY
1		CAPTRATE SOLID FILTER	7	16"	16"	85% SEE FILTER SPEC	6	L55 SERIES E26	NO	RIGHT	12"x54"x24"	ANSUL R-102	3.0/3.0	SC-110110MA	1 LIGHT 1 FAN	YES	686 LBS

HOOD OPTIONS

HOOD NO	TAG	OPTION
1		FIELD WRAPPER 10.00" HIGH FRONT, LEFT, RIGHT. INSULATION FOR BACK OF HOOD. RISER SENSOR INSTALL 6IN PLEN. RIGHT VERTICAL END PANEL 27" TOP WIDTH, 21" BOTTOM WIDTH, 80" HIGH INSULATED 430 SS. LEFT VERTICAL END PANEL 27" TOP WIDTH, 21" BOTTOM WIDTH, 80" HIGH INSULATED 430 SS. FULL DIMENSION HANGING BRACKET - FRONT.

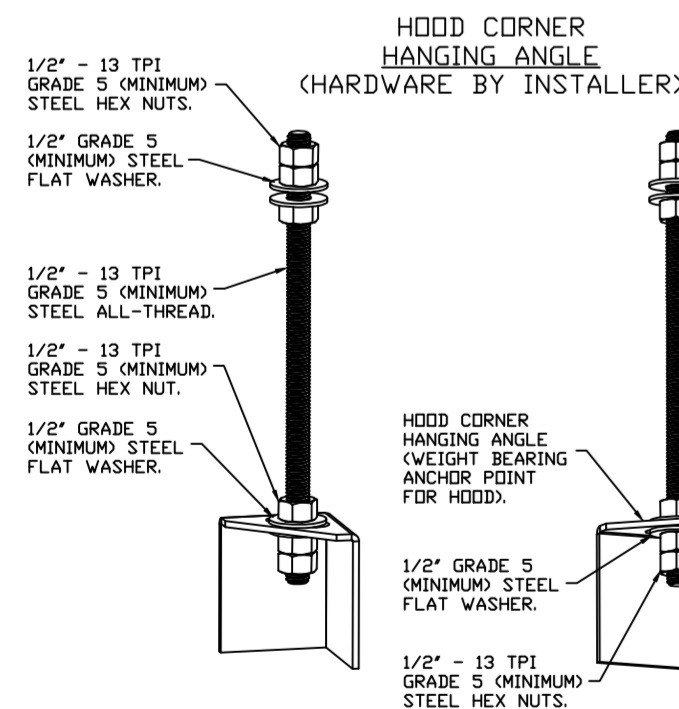
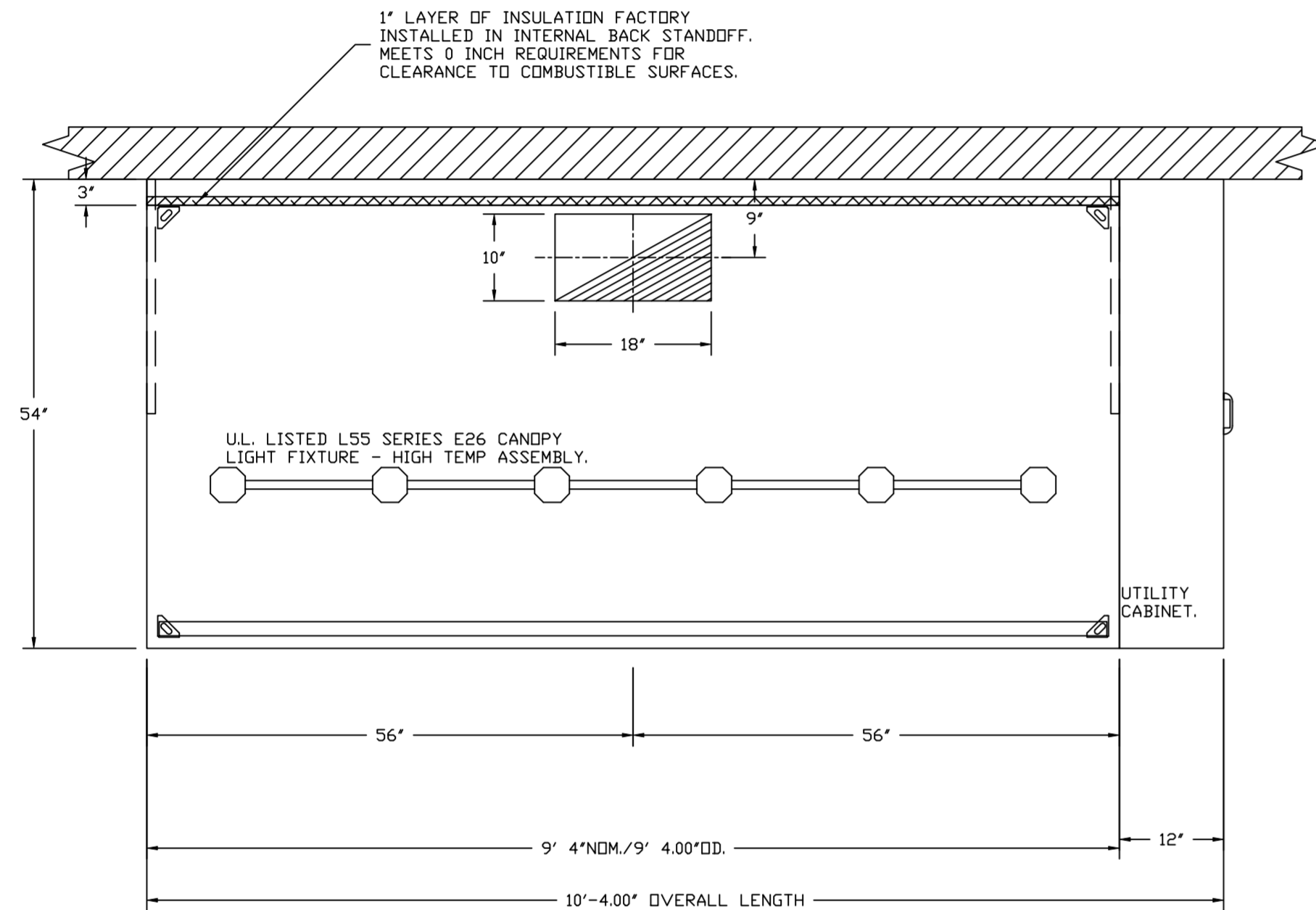

ASSEMBLY INSTRUCTIONS

HANGING ANGLE MUST BE SUPPORTED WITH 1/2" - 13 TPI GRADE 5 (MINIMUM) ALL-THREAD, SANDWICH HANGING ANGLES AND CEILING ANCHOR POINTS WITH 1/2" GRADE 5 (MINIMUM) STEEL FLAT WASHERS AND 1/2" - 13 TPI GRADE 5 (MINIMUM) HEX NUTS AS SHOWN. MUST USE DOUBLED HEX NUT CONFIGURATION BENEATH HOOD HANGING ANGLES AND ABOVE CEILING ANCHORS. MAINTAIN 1/4" OF EXPOSED THREADS BENEATH BOTTOM HEX NUT. TORQUE ALL HEX NUTS TO 57 FT-LBS.

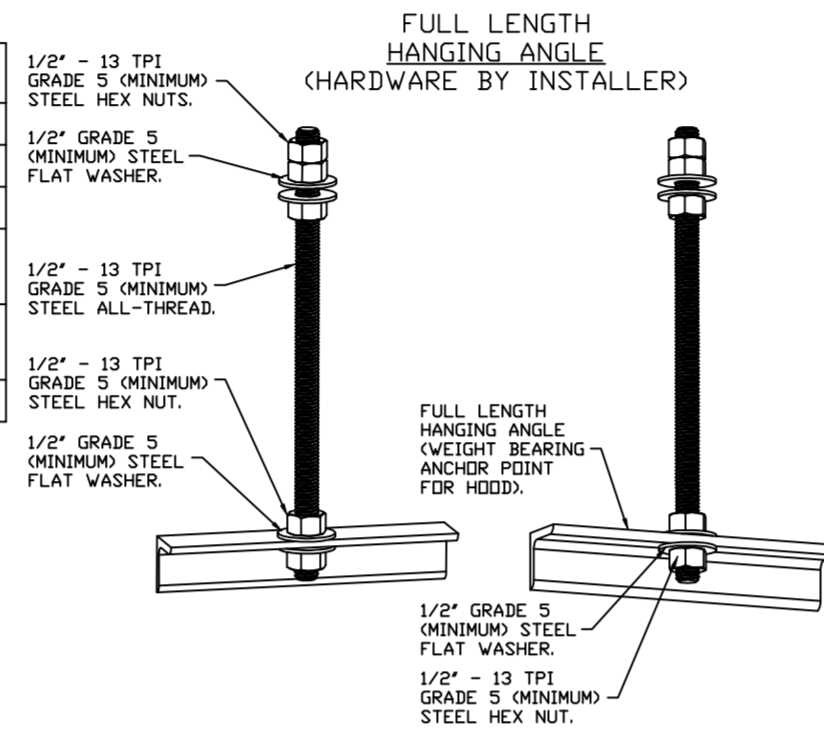

ASSEMBLY INSTRUCTIONS

HANGING ANGLE MUST BE SUPPORTED WITH 1/2" - 13 TPI GRADE 5 (MINIMUM) ALL-THREAD, SANDWICH HANGING ANGLES AND CEILING ANCHOR POINTS WITH 1/2" GRADE 5 (MINIMUM) STEEL FLAT WASHERS AND 1/2" - 13 TPI GRADE 5 (MINIMUM) HEX NUTS AS SHOWN. MUST USE DOUBLED HEX NUT CONFIGURATION ABOVE CEILING ANCHORS. SINGLE HEX NUT BENEATH HANGING ANGLE IS ACCEPTABLE FOR FULL LENGTH HANGING ANGLES. MAINTAIN 1/4" OF EXPOSED THREADS BENEATH BOTTOM HEX NUT. TORQUE ALL HEX NUTS TO 57 FT-LBS.

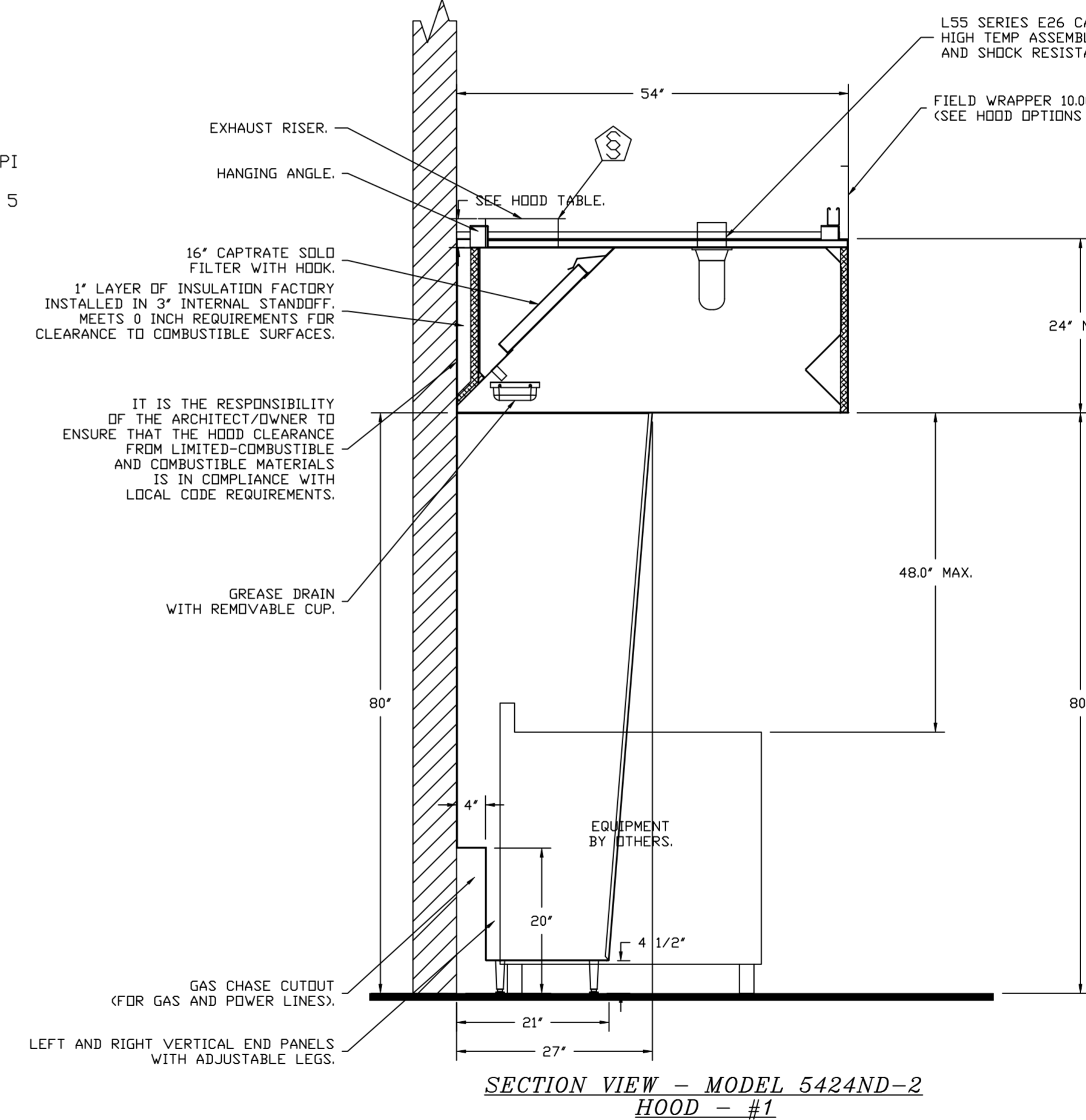

FIRE SYSTEM INFORMATION - JOB#6029518

FIRE SYSTEM NO	TAG	TYPE	SIZE	FLOW POINTS	INSTALLATION	
					SYSTEM	LOCATION ON HOOD
1		ANSUL R102	3.0/3.0	14	FIRE CABINET RIGHT	RIGHT, HOOD 1

SPECIFICATION: CAPTRATE® GREASE-STOP® SOLID FILTER

THE CAPTRATE GREASE-STOP SOLID FILTER IS A SINGLE-STAGE FILTER FEATURING A UNIQUE S-Baffle DESIGN IN CONJUNCTION WITH A SLOTTED REAR Baffle DESIGN, TO DELIVER EXCEPTIONAL FILTRATION EFFICIENCY.

FILTER IS STAINLESS STEEL CONSTRUCTION, AND SIZED TO FIT INTO STANDARD 2-INCH DEEP HOOD CHANNEL(S).

UNITS SHALL INCLUDE STAINLESS STEEL HANDLES AND A FASTENING DEVICE TO SECURE THE TWO COMPONENTS WHEN ASSEMBLED.

GREASE EXTRACTION EFFICIENCY PERFORMANCE SHALL REMOVE AT LEAST 75% OF GREASE PARTICLES FIVE MICRONS IN SIZE, AND 85% GREASE PARTICLES SEVEN MICRONS IN SIZE AND LARGER, WITH A CORRESPONDING PRESSURE DROP NOT TO EXCEED 1.0 INCHES OF WATER GAUGE.

THE CAPTRATE GREASE-STOP SOLID WAS TESTED TO ASTM STANDARD ASTM F2519-05. MANUFACTURER APPROVED FOR USE IN SOLID FUEL APPLICATIONS AS A SPARK ARRESTER.

EFFICIENCY VS. PARTICLE DIAMETER

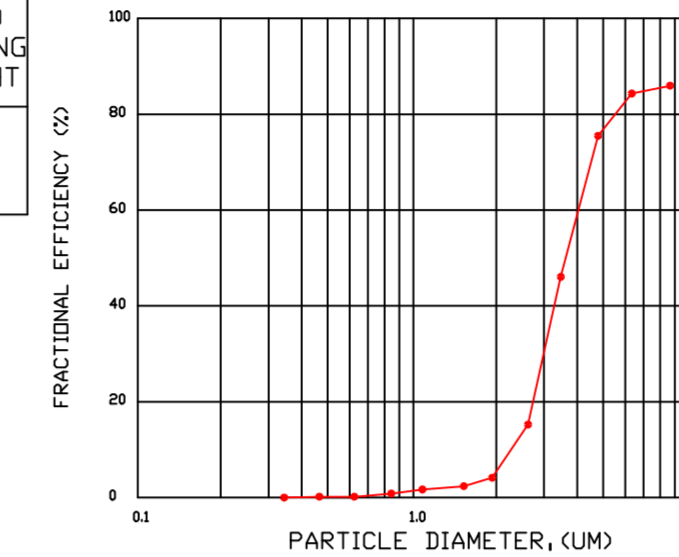

PRESSURE DROP VS. FLOW RATE

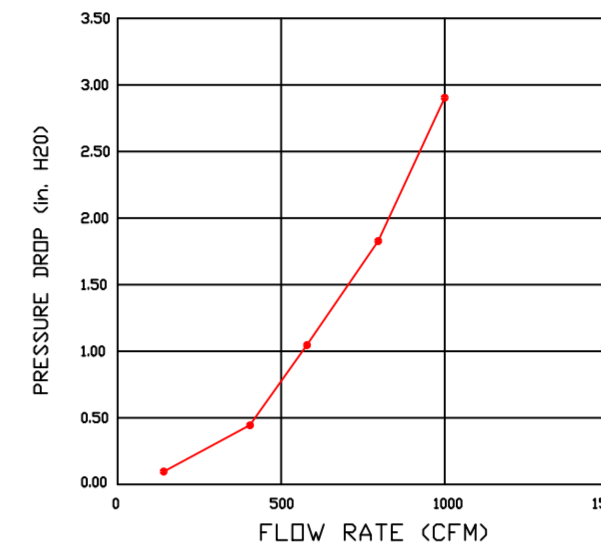

CAPTRATE FILTERS ARE BUILT IN COMPLIANCE WITH:
NFPA #96.
NSF STANDARD #2.
UL STANDARD #1046.
INT. MECH. CODE (IMC).
ULC-S649.



REVISIONS

DESCRIPTION	DATE

CAPTIVEAIRE

Highwoods Group

4641 Paragon Park Rd., Raleigh, NC 27616 PHONE: (919) 875-0420 FAX: (919) 875-0577 EMAIL: reg40@captiveaire.com

CHIPOTLE ROCK HILL #4912
SAINT LOUIS, MO, 63141

DATE: 5/30/2023
DWG.#: 6029518
DRAWN BY: JMB-40
SCALE: 3/4" = 1'-0"
MASTER DRAWING

SHEET NO.
1

EXHAUST FAN INFORMATION - JOB#6029518

FAN UNIT NO	TAG	QTY	FAN UNIT MODEL #	MANUFACTURER	CFM	ESP	RPM	MOTOR ENCL	HP	BHP	PHASE	VOLT	FLA	DISCHARGE VELOCITY	WEIGHT (LBS)	SDNES
1	EF-1	1	DU85HFA	CAPTIVEAIRE	1900	1.200	1484	TEAD-ECM	1.000	0.5780	1	115	11.6	601 FPM	93	14.4
2	EF-2	1	DR12HFA	CAPTIVEAIRE	150	0.500	1181	TEAD-ECM	0.250	0.0720	1	115	2.9		50	5.1

FAN OPTIONS

FAN UNIT NO	TAG	QTY	DESCRIPTION
1	EF-1	1	GREASE BDX
		1	REMOVE HINGE KIT LABEL FROM THE FAN BASE
		1	ECM WIRING PACKAGE - PWM SIGNAL FROM ECPM03 PREWIRE (TELCO MOTOR), CCW ROTATION
		1	2 YEAR PARTS WARRANTY
2	EF-2	1	ECM WIRING PACKAGE - EXHAUST - MANUAL DR 0-10VDC REFERENCE SPEED CONTROL -MSC- (TELCO), CCW ROTATION
		1	I 12-BDD DAMPER
		1	2 YEAR PARTS WARRANTY

FAN ACCESSORIES

FAN UNIT NO	TAG	EXHAUST				SUPPLY			
		GREASE CUP	GRAVITY DAMPER	WALL MOUNT	SIDE DISCHARGE	GRAVITY DAMPER	MOTORIZED DAMPER	WALL MOUNT	
1	EF-1	YES							
2	EF-2		YES						

CURB ASSEMBLIES

NO	ON FAN	TAG	WEIGHT	ITEM	SIZE
1	# 1	EF-1	32 LBS	CURB	23.000"W X 23.000"L X 20.000"H ALONG LENGTH, RIGHT VENTED.
2	# 2	EF-2	31 LBS	CURB	17.500"W X 17.500"L X 26.000"H ALONG LENGTH, RIGHT.

FAN #1 DU85HFA - EXHAUST FAN (EF-1)

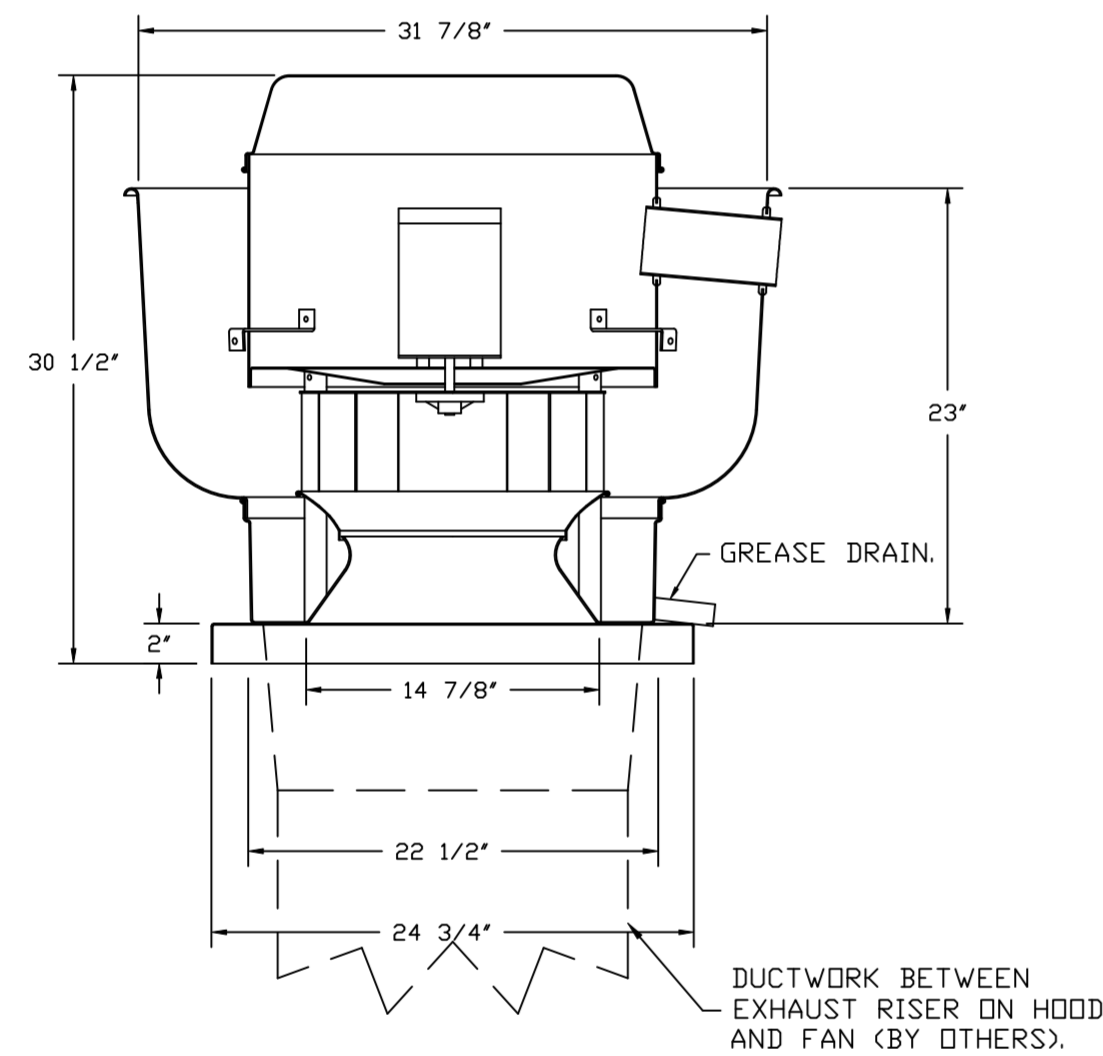

FEATURES:

- DIRECT DRIVE CONSTRUCTION (NO BELTS/PULLEYS).
- ROOF MOUNTED FANS.
- RESTAURANT MODEL.
- UL705 AND UL762 AND ULC-S645
- VARIABLE SPEED CONTROL.
- INTERNAL WIRING.
- THERMAL OVERLOAD PROTECTION (SINGLE PHASE).
- HIGH HEAT OPERATION 300°F (149°C).
- GREASE CLASSIFICATION TESTING.
- NEMA 3R SAFETY DISCONNECT SWITCH.

NORMAL TEMPERATURE TEST

EXHAUST FAN MUST OPERATE CONTINUOUSLY WHILE EXHAUSTING AIR AT 300°F (149°C) UNTIL ALL FAN PARTS HAVE REACHED THERMAL EQUILIBRIUM, AND WITHOUT ANY DETERIORATING EFFECTS TO THE FAN WHICH WOULD CAUSE UNSAFE OPERATION.

ABNORMAL FLARE-UP TEST

EXHAUST FAN MUST OPERATE CONTINUOUSLY WHILE EXHAUSTING BURNING GREASE VAPORS AT 600°F (316°C) FOR A PERIOD OF 15 MINUTES WITHOUT THE FAN BECOMING DAMAGED TO ANY EXTENT THAT COULD CAUSE AN UNSAFE CONDITION.

OPTIONS

- GREASE BDX.
- REMOVE HINGE KIT LABEL FROM THE FAN BASE.
- ECM WIRING PACKAGE - PWM SIGNAL FROM ECPM03 PREWIRE (TELCO MOTOR), CCW ROTATION.
- 2 YEAR PARTS WARRANTY.

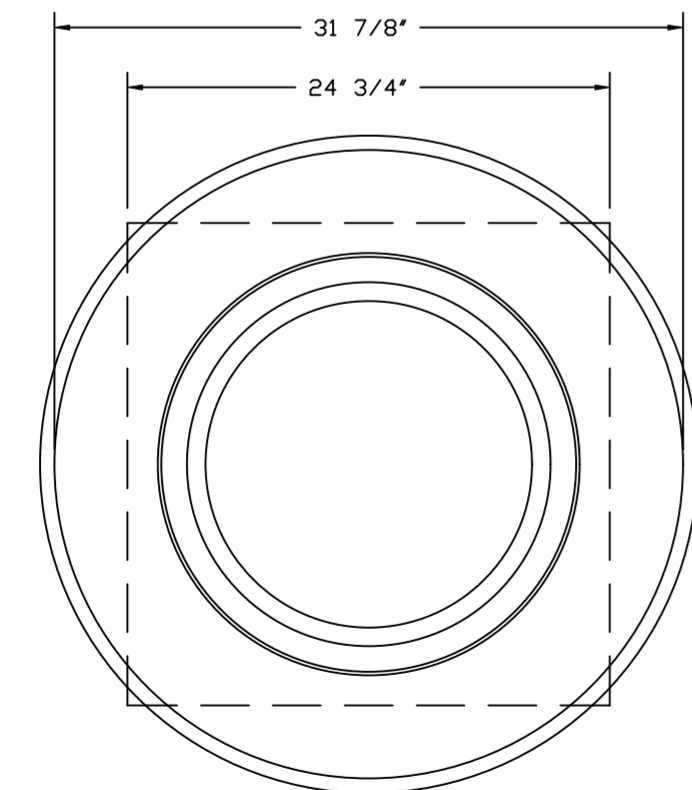

TOP VIEW

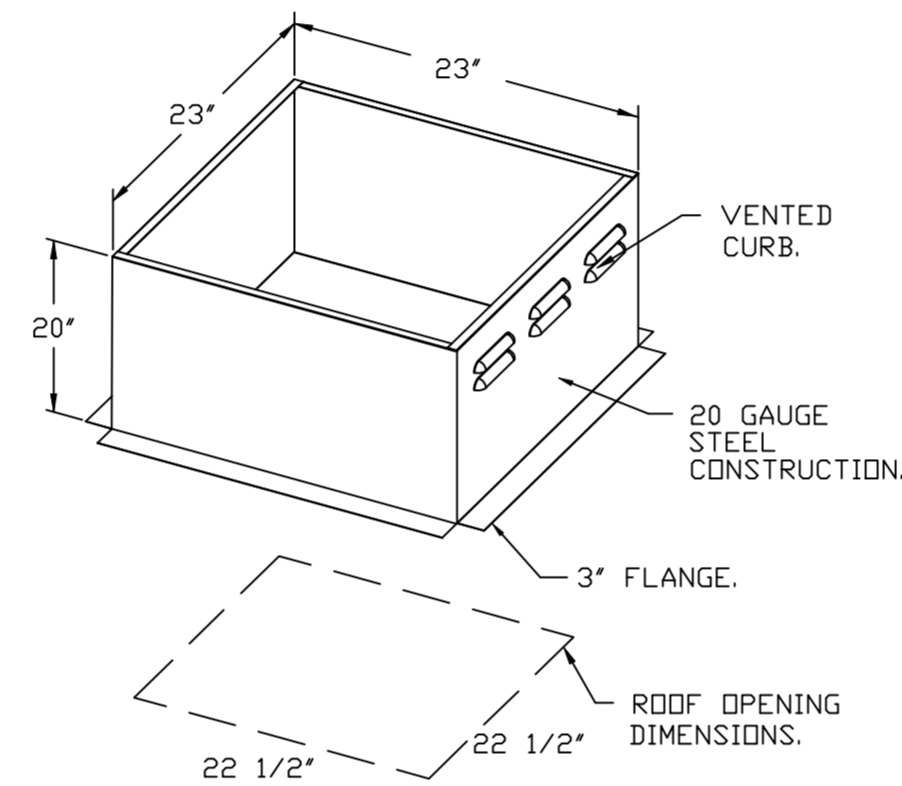

REVISIONS

DESCRIPTION	DATE

www.captiveair.com
4641 Paragon Park Rd., Raleigh, NC 27616 PHONE: (919) 875-0420 FAX: (919) 875-0577 EMAIL: reg10@captiveair.com

CHIPOTLE ROCK HILL #4912
SAINT LOUIS, MO, 63141

DATE: 5/30/2023
DWG.#: 6029518
DRAWN BY: JMB-40
SCALE: 3/4" = 1'-0"
MASTER DRAWING

SHEET NO. 2

FAN #2_DR12HFA - EXHAUST FAN (CF-22)

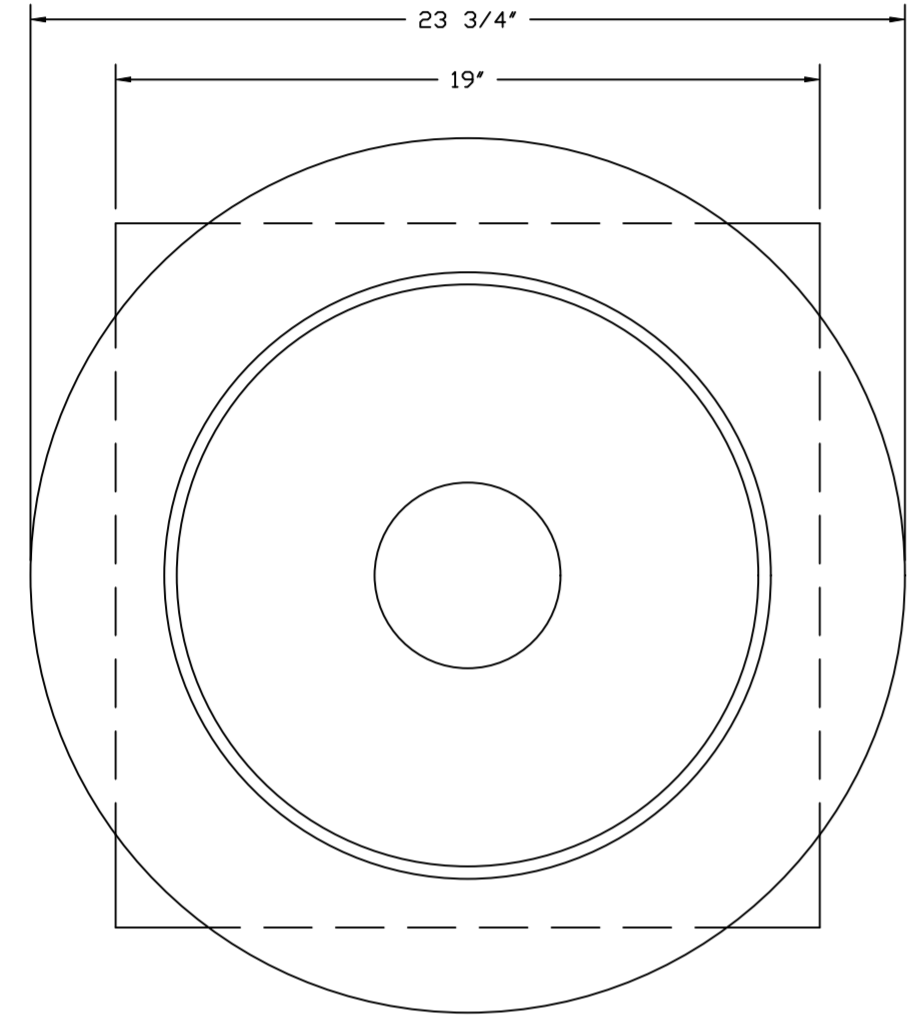
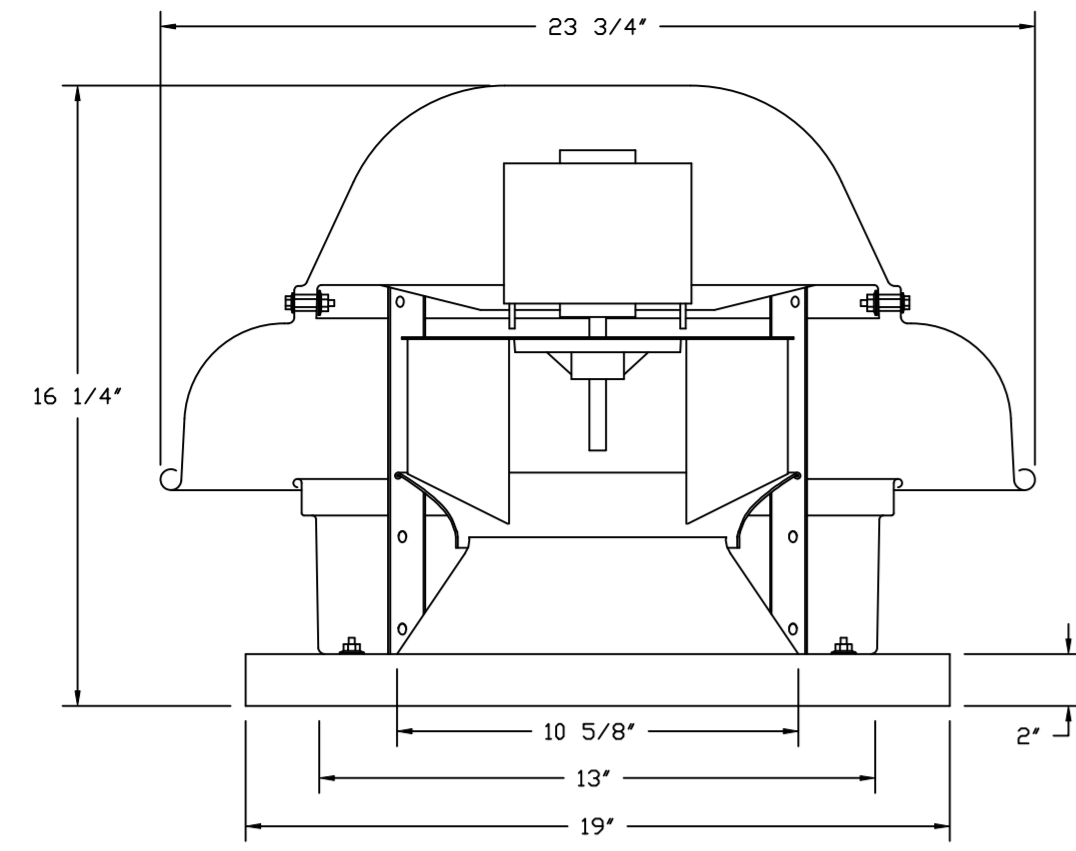

TOP VIEW

FEATURES:

- DIRECT DRIVE CONSTRUCTION (NO BELTS/PULLEYS).
- ROOF MOUNTED FANS.
- UL705.
- SAFETY DISCONNECT.
- STANDARD BIRD SCREEN.
- SPEED CONTROL.
- THERMAL OVERLOAD PROTECTION (SINGLE PHASE).

OPTIONS:

- ECM WIRING PACKAGE - EXHAUST - MANUAL OR 0-10VDC REFERENCE SPEED CONTROL - MSC - (TELCD), CCW ROTATION.
- 1 12-IDD DAMPER.
- 2 YEAR PARTS WARRANTY.

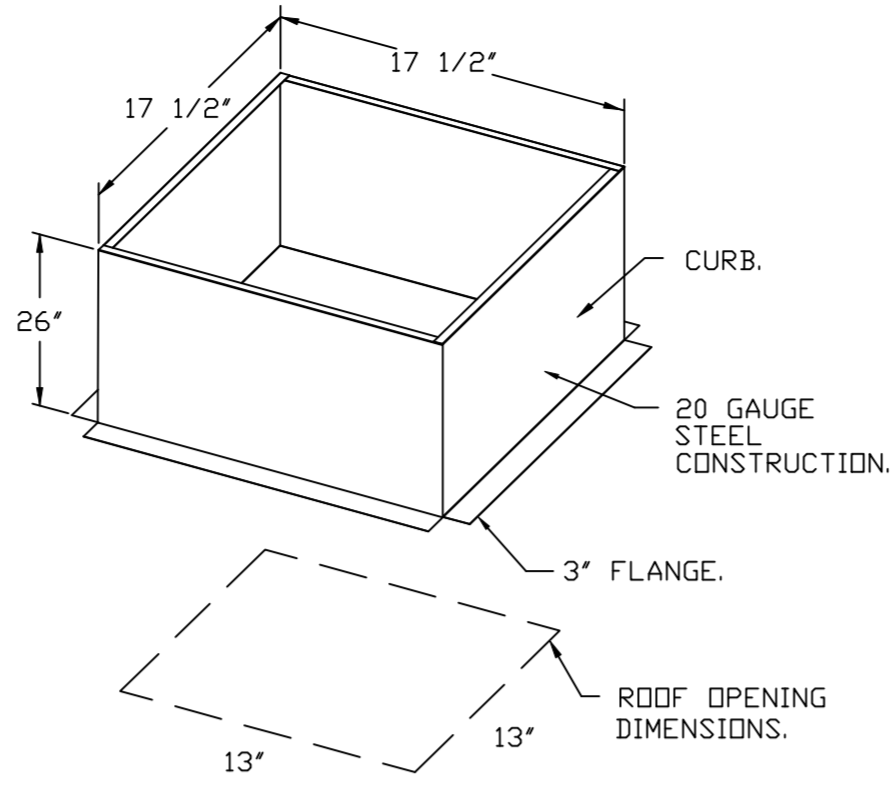

BACKDRAFT DAMPER INSTALLATION

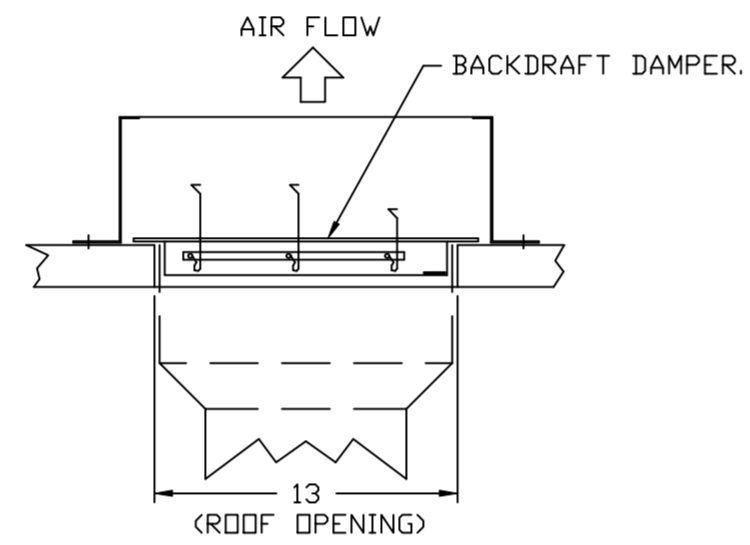

REVISIONS

DESCRIPTION	DATE:

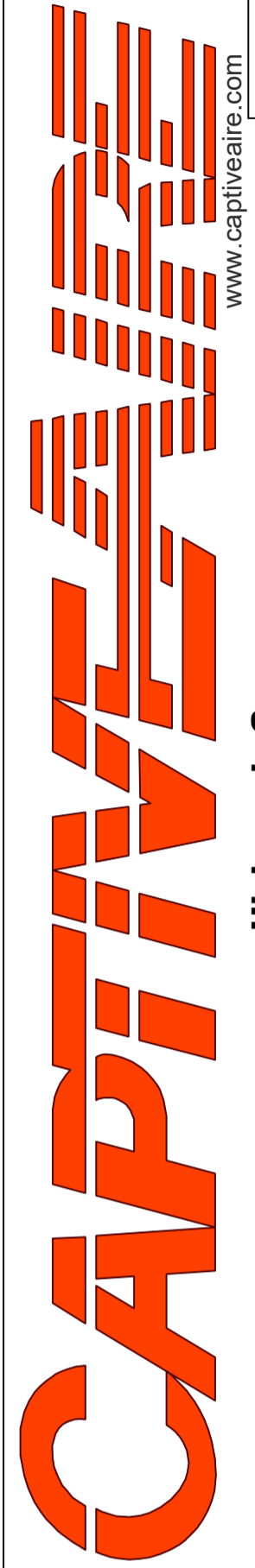
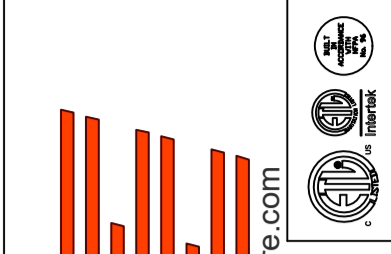

Highwoods Group
 4641 Paragon Park Rd., Raleigh, NC, 27616 PHONE: (919) 875-0420 FAX: (919) 875-0577 EMAIL: reg10@captiveware.com

CHIPOTLE ROCK HILL #4912
 SAINT LOUIS, MO, 63141

DATE: 5/30/2023

DWG.#: 6029518

DRAWN BY: JMB-40

SCALE: 3/4" = 1'-0"

MASTER DRAWING

SHEET NO. 3

ELECTRICAL PACKAGE - JOB#6029518

NO	TAG	PACKAGE #	LOCATION	SWITCHES		OPTION	FANS CONTROLLED					
				LOCATION	QUANTITY		FAN TAG	TYPE	#	HP	VOLT	FLA
1		SC-110110MA	UTILITY CABINET RIGHT	UTILITY CABINET RIGHT HOOD # 1	1 LIGHT 1 FAN	SMART CONTROLS THERMOSTATIC CONTROL W/ RELAY ON/OFF WITH SUPPLY	EF-1	EXHAUST	1	1.000	115	11.6

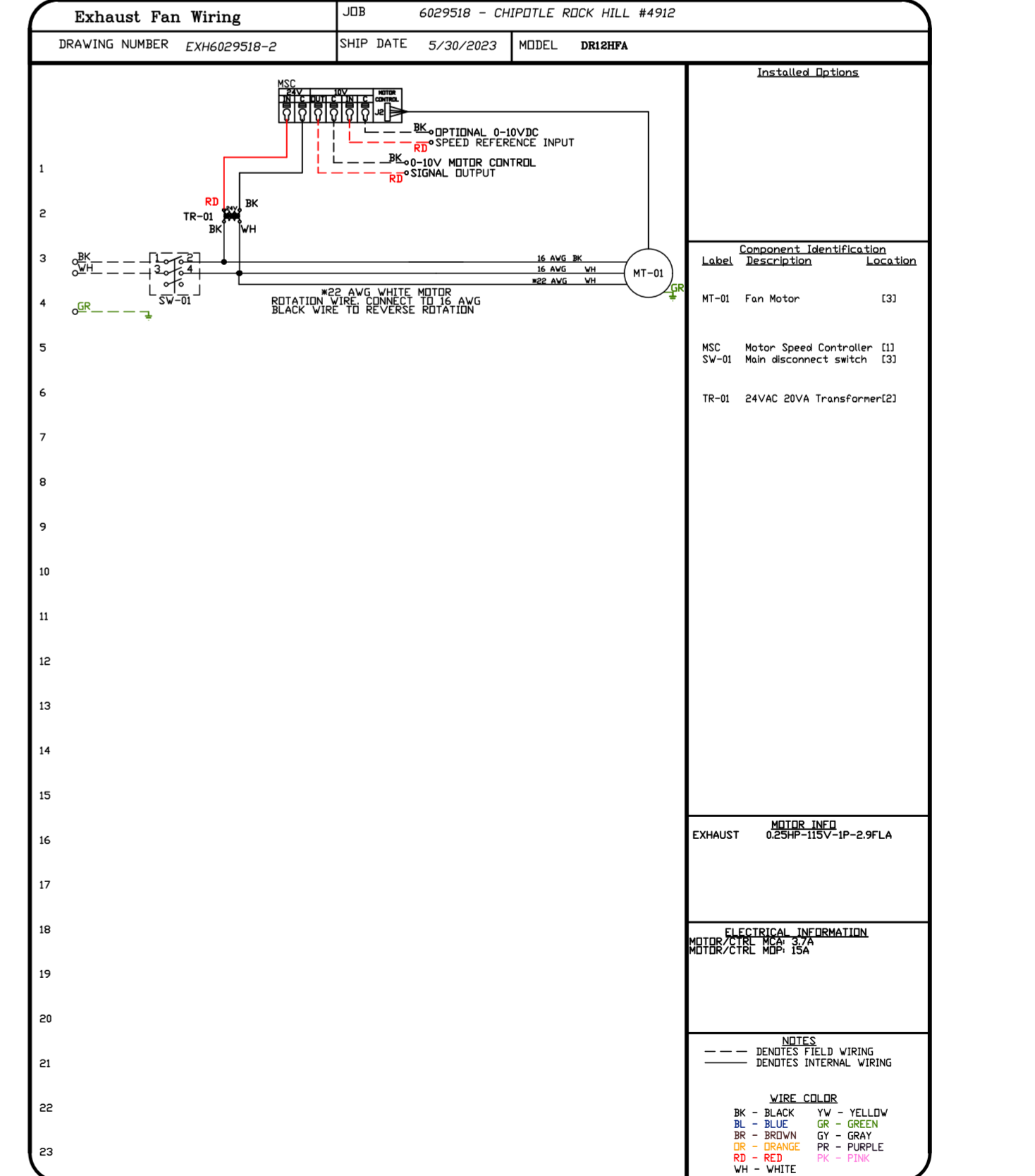
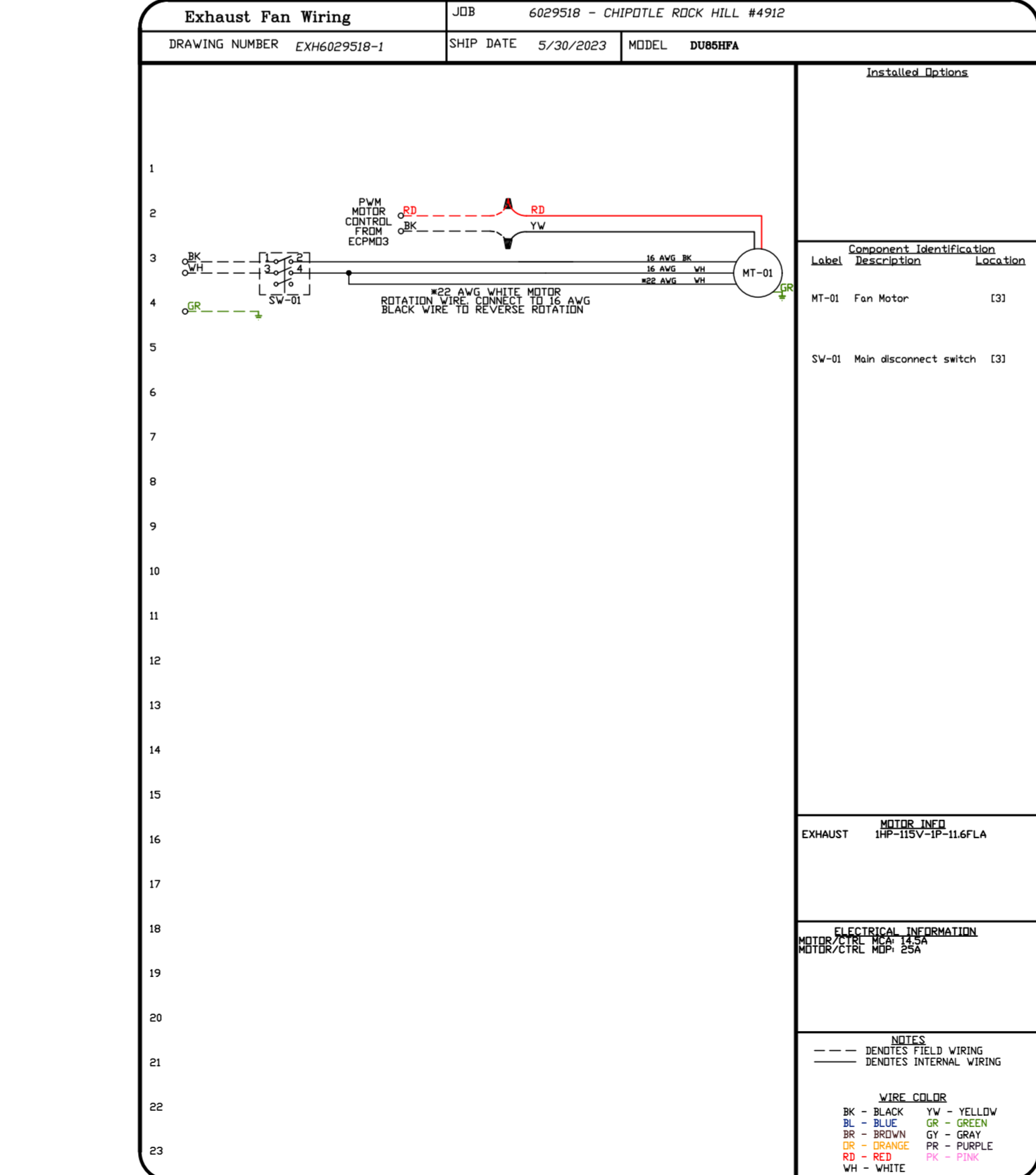
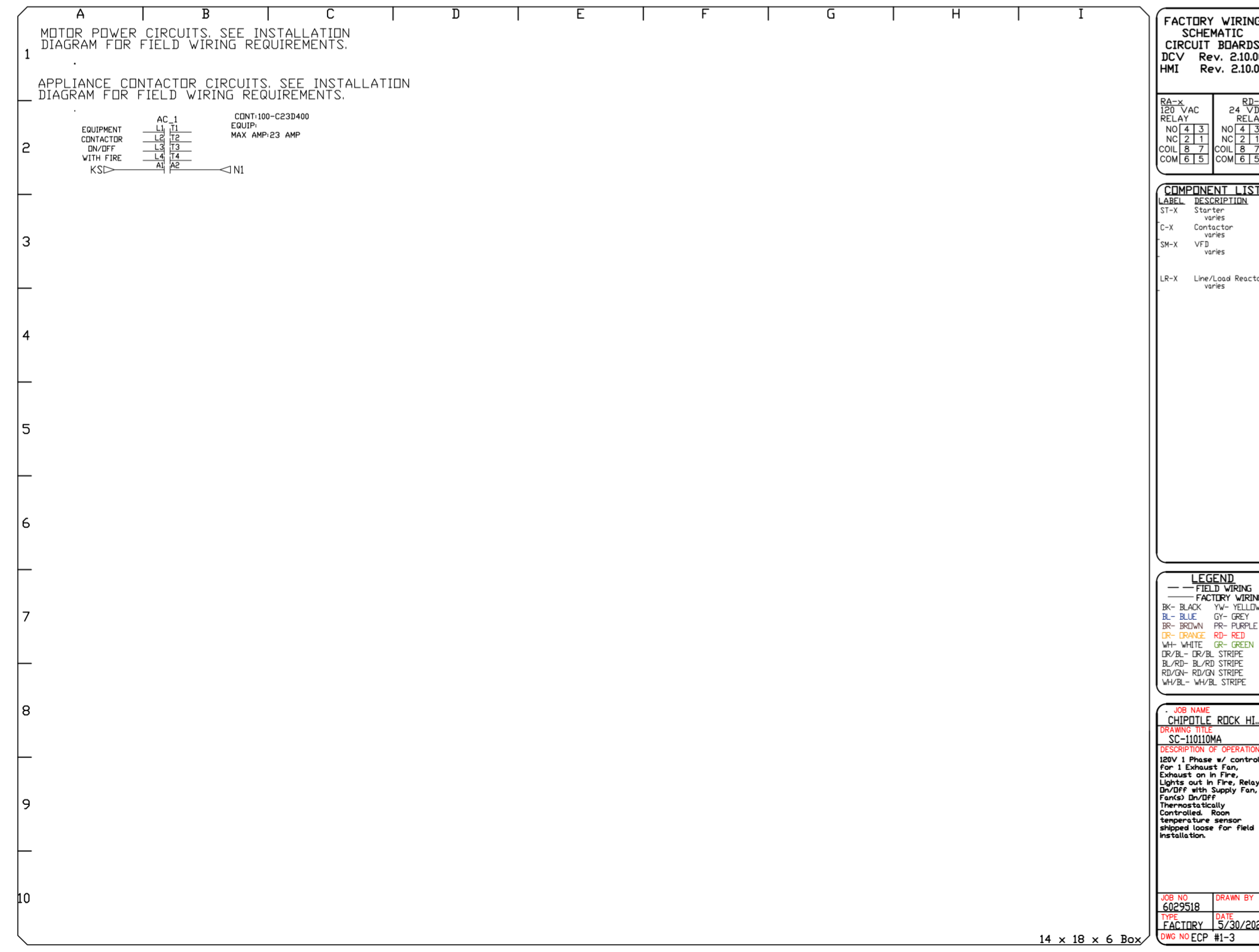
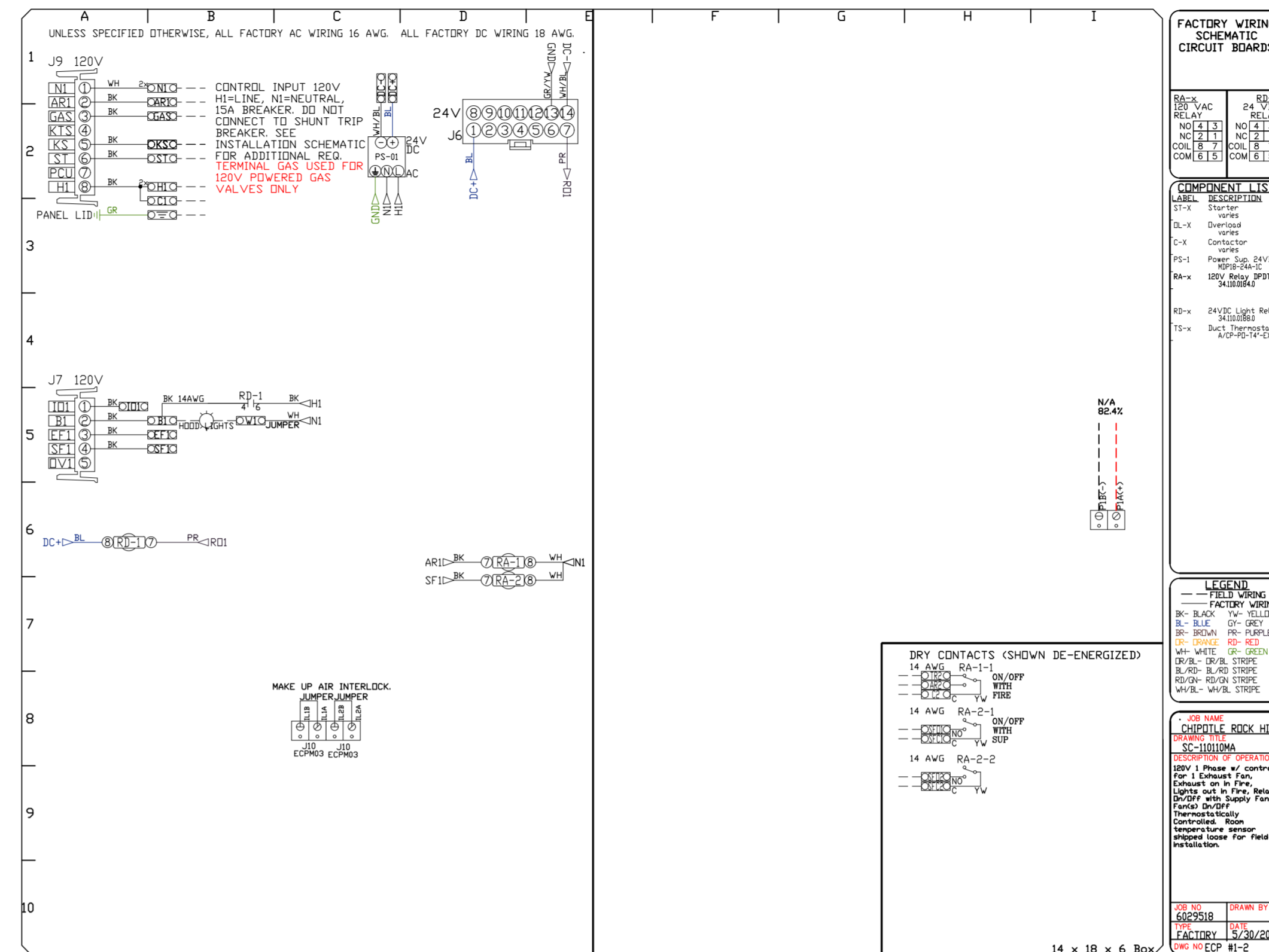
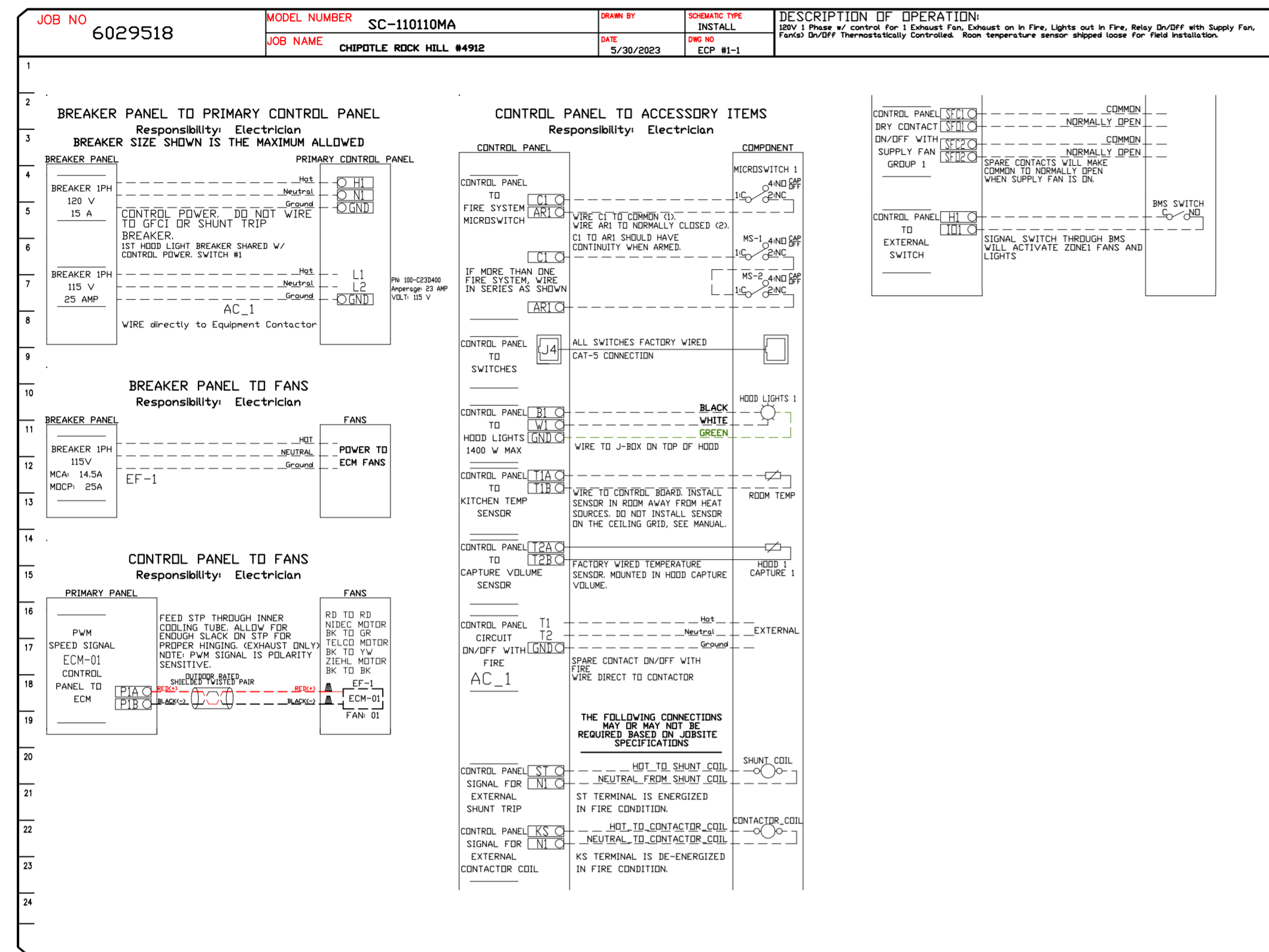

REVISIONS

DESCRIPTION	DATE

CHIPOTLE ROCK HILL #4912

SAINT LOUIS, MO, 63141

DATE: 5/30/2023
DWG.#: 6029518
DRAWN BY: JMB-40
SCALE: 3/4" = 1'-0"
MASTER DRAWING

SHEET NO.
4

CAPTIVE

Highwoods Group
 www.captive.com
 4641 Paragon Park Rd., Raleigh, NC 27616 PHONE: (919) 875-0420 FAX: (919) 875-0577 EMAIL: reg@captiveware.com