



GENERAL MECHANICAL SYMBOLS

	REVISION NUMBER - SHOWN ON PLANS
	POINT WHERE NEW CONNECTS TO EXISTING
	NUMBER OF DETAIL ON SHEET
	NUMBER OF SHEET WHERE DETAIL APPEARS
	KEYNOTE
	CONTINUATION SYMBOL
	ROOM NAME AND NUMBER
	ITEM TO BE DEMOLISHED
	AREA NOT IN CONTRACT
	PIPE SIZE TAG (DIAMETER)
	ABOVE GROUND PIPING
	PIPE SLOPE TAG
	BELOW GROUND PIPING
	PIPE INVERT ELEVATION TAG
	EXISTING PIPE TAG
	PIPING BEING DEMOLISHED

ABBREVIATIONS

Ø	ROUND	LVR	LOUVER
ABV	ABOVE	LWT	LEAVING WATER TEMPERATURE
AC	AIR CONDITIONING	M/A	MIXED AIR
AD	AREA DRAIN	MAX	MAXIMUM
ADD	ADDENDUM	MBH	ONE THOUSAND BTU PER HOUR
AF	ABOVE FINISHED FLOOR	MCF	ONE THOUSAND CUBIC FEET
AFUE	ANNUAL FUEL UTILIZATION EFFICIENCY	MD	MOTORIZED DAMPER
ALT	ALTERNATE	MECH	MECHANICAL
AP	ACCESS PANEL	MFR	MANUFACTURER
ARCH	ARCHITECT/ARCHITECTURAL	MIN	MINIMUM
BFF	BELOW FINISHED FLOOR	MISC	MISCELLANEOUS
BLW	BELOW	MTR	MOTOR
BTU	BRITISH THERMAL UNITS	MUA	MAKE-UP/AIR
BTUH	BRITISH THERMAL UNITS PER HOUR	NC	NOISE CRITERIA
CAP	CAPACITY	NC	NORMALLY CLOSED
CB	CATCH BASIN	NIC	NOT IN CONTRACT
CFM	CUBIC FEET PER MINUTE	NO	NUMBER
CLS	CEILING	NO	NORMALLY OPEN
CO	CLEAN OUT	NTS	NOT TO SCALE
CW	COLD WATER	O	OXYGEN
D	DEGREE	O/A	OUTSIDE AIR
DB	DRY BULB	ORD	OVERFLOW ROOF DRAIN
DIA	DIAMETER	PD	PRESSURE DROP
DN	DOWN	PIV	POST INDICATOR VALVE
DW	DISTILLED WATER	PLBG	PLUMBING
EA	EACH	PRESS	PRESSURE
EAT	ENTERING AIR TEMPERATURE	PRV	PRESSURE REDUCING VALVE
ELEC	ELECTRICAL	PSI	POUNDS PER SQUARE INCH
EQUIP	EQUIPMENT	PSIG	POUNDS PER SQUARE INCH GAUGE
EWC	ELECTRIC WATER COOLER	PWR	POWER
EWT	ENTERING WATER TEMPERATURE	R	DUCT RISER
E/A	EXHAUST AIR	R/A	RETURN AIR
EXIST	EXISTING	RCP	RADIANT CEILING PANEL
F	DEGREES FAHRENHEIT	RD	ROOF DRAIN
FCO	FLOOR CLEAN OUT	REC	RECESSED
FD	FLOOR DRAIN	RED	REDUCER
FDC	FIRE DEPARTMENT CONNECTION	RH	RELATIVE HUMIDITY
FL	FLOOR	RLA	RELIEF AIR
FO	FUEL OIL	RM	ROOM
FOV	FUEL OIL VENT	RPM	REVOLUTIONS PER MINUTE
FOR	FUEL OIL RETURN	RW	RAIN WATER
FOS	FUEL OIL SUPPLY	SF	SQUARE FOOT
FPM	FEET PER MINUTE	S/A	SUPPLY AIR
FS	FLOOR SINK	SAN	SANITARY
FT	FOOT/FEET	SF	SQUARE FOOT
FTR	FIN TUBE RADIATION	SD	SMOKE DAMPER
GAL	GALLON	SM	SURFACE MOUNT
GF	GAS-FIRED	SP	STANDPIPE
GC	GENERAL CONTRACTOR	SP	STATIC PRESSURE
GPM	GALLONS PER MINUTE	STM	STEAM
GW	GREASE WASTE	T	THERMOSTAT
HB	HOSE BIB	TD	TEMPERATURE DROP
HP	HORSE POWER	TDR	TRENCH DRAIN
HTG	HEATING	TEMP	TEMPERATURE
HTR	HEATER	TYP	TYPICAL
HW	HOT WATER	UG	UNDERGROUND
HYD	HYDRANT	VAC	VACUUM
ID	INDIRECT	V	VENT
IN	INCH	VAV	VARIABLE AIR VOLUME
INV	INVERT	VENT	VENTILATION
LB	POUND	VTR	VENT THROUGH ROOF
LB/HR	POUNDS PER HOUR	W	WASTE
LAT	LEAVING AIR TEMPERATURE	WB	WET BULB
LP	LOW PRESSURE	WCO	WALL CLEAN OUT
LPG	LIQUEFIED PETROLEUM GAS	WH	WALL HYDRANT

EQUIPMENT ABBREVIATIONS

AC	AIR CONDITIONING UNIT	ET	EXPANSION TANK
ACCU	AIR COOLING CONDENSING UNIT	EWH	ELECTRIC WATER HEATER
AHU	AIR HANDLING UNIT	FCU	FAN COIL UNIT
AS	AIR SEPARATOR	FP	FIRE PUMP
B	BOILER	GI	GREASE INTERCEPTOR
CH	CHILLER	GRV	GRAVITY ROOF VENTILATOR
CT	COOLING TOWER	HWP	HEATING WATER PUMP
CUH	CABINET UNIT HEATER	HRU	HEAT RECOVERY UNIT
CHWP	CHILLED WATER PUMP	PRV	POWER ROOF VENTILATOR
DBP	DOMESTIC WATER BOOSTER PUMP	RE	RETURN/EXHAUST FAN
DC	DUCT MOUNTED COIL	RTU	ROOFTOP UNIT
DCP	DOMESTIC WATER CIRCULATING PUMP	SP	SUMP PUMP
EF	EXHAUST FAN	UH	UNIT HEATER
EDC	ELECTRIC DUCT COIL	WH	WATER HEATER

NOTE
ALL OF GENERAL NOTES ON THIS SHEET ARE TO BE APPLIED TO ALL OTHER DRAWINGS IN THIS SET. THE SYMBOLS AND ABBREVIATIONS SHOWN ON THIS SHEET MAY OR MAY NOT BE USED IN THIS SET OF DRAWINGS.

HVAC SYMBOLS

	SQUARE DUCT SIZE TAG (WIDTH x HEIGHT)
	OVAL DUCT SIZE TAG (WIDTH / HEIGHT)
	ROUND DUCT SIZE TAG (DIAMETER)
	EXISTING DUCT TAG
	DUCT BEING DEMOLISHED
	SUPPLY AIR
	CONDITIONED OUTSIDE AIR
	OUTSIDE AIR
	RETURN AIR
	TRANSFER AIR
	EXHAUST AIR
	RELIEF AIR
	GREASE EXHAUST AIR
	CONDENSATE EXHAUST AIR
	SMOKE EXHAUST AIR
	EXHAUST GAS FLUE
	COMBUSTION AIR

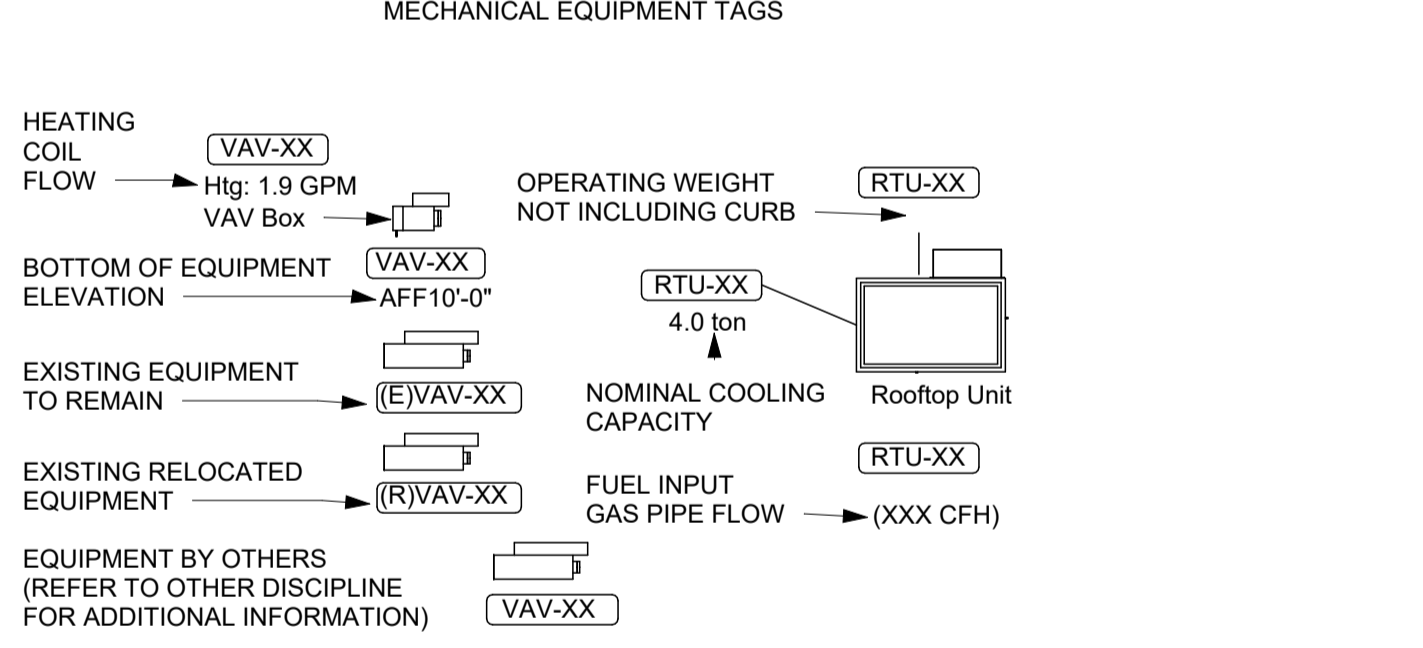
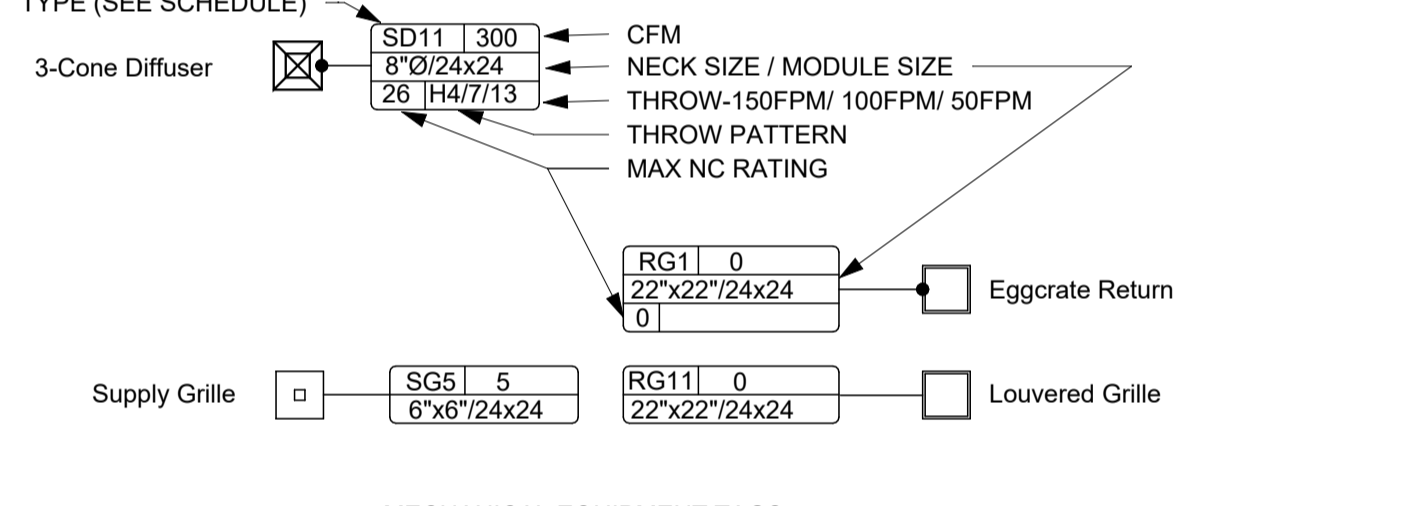

DAMPER TAGS

	Smoke Damper
	Fire Damper
	Comb. Fire/Smoke Damper
	Manual Damper
	Motorized Damper
	Backdraft Damper

PIPING SYMBOLS

	CHILLED WATER RETURN
	CHILLED WATER SUPPLY
	CONDENSATE DRAINAGE
	CONDENSER WATER RETURN
	CONDENSER WATER SUPPLY
	GEO THERMAL WATER RETURN
	GEO THERMAL WATER SUPPLY
	HEATING WATER RETURN
	HEATING WATER SUPPLY
	NATURAL GAS
	PROPANE GAS
	REFRIGERANT-LIQUID
	REFRIGERANT-SUCTION
	REFRIGERANT-HOT GAS
	STEAM
	CONDENSATE RETURN

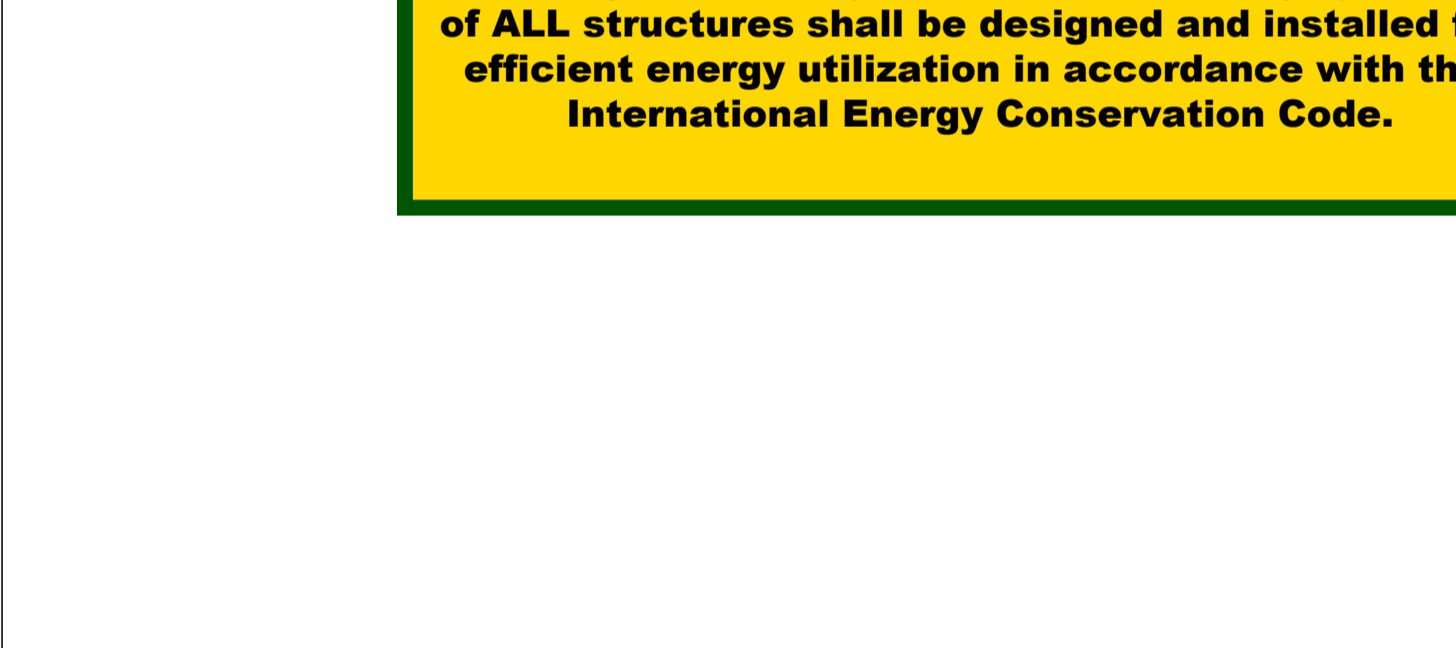
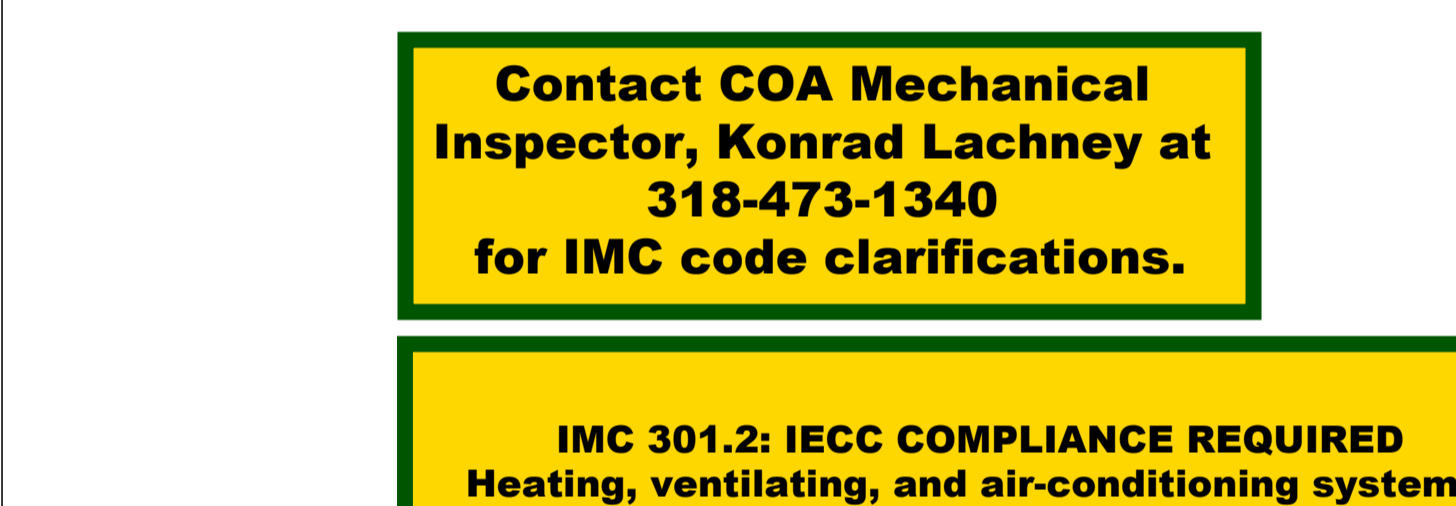

Contact COA Mechanical Inspector, Konrad Lachney at 318-473-1340 for IMC code clarifications.

IMC 301.2: IECC COMPLIANCE REQUIRED Heating, ventilating, and air-conditioning systems of ALL structures shall be designed and installed for efficient energy utilization in accordance with the International Energy Conservation Code.

a new restaurant for:
Lot 6A MacArthur Dr
Alexandria, LA 71301

date
07/28/2023
drawn by
Author
checked by
Checker
revisions

sheet number
M-000

drawing type
PROTOTYPE DOCUMENTS
project number
23472

This drawing has been prepared by the Engineer, or under his supervision. This drawing is provided as an instrument of service by the Designer/Engineer and is intended for use on the project only. Pursuant to the Architectural Works Copyright Protection Act of 1990, all drawings, specifications, ideas and designs, including the overall form, arrangement and composition of graphic elements appearing herein, constitute the original, copyrighted work of the Designer/Engineer. Any reproduction, use, or disclosure of information contained herein without prior written consent of the Engineer is strictly prohibited. © 2023 BC Engineers, Inc.

BC ENGINEERS INCORPORATED
5720 Reeder Shawnee, KS 66203 (913)262-1772



IMC 107.2(2) Mechanical Contractor shall call for an inspection of installation, including all seams, joints, and connections prior to concealment by duct wrap or wall and ceiling membranes.

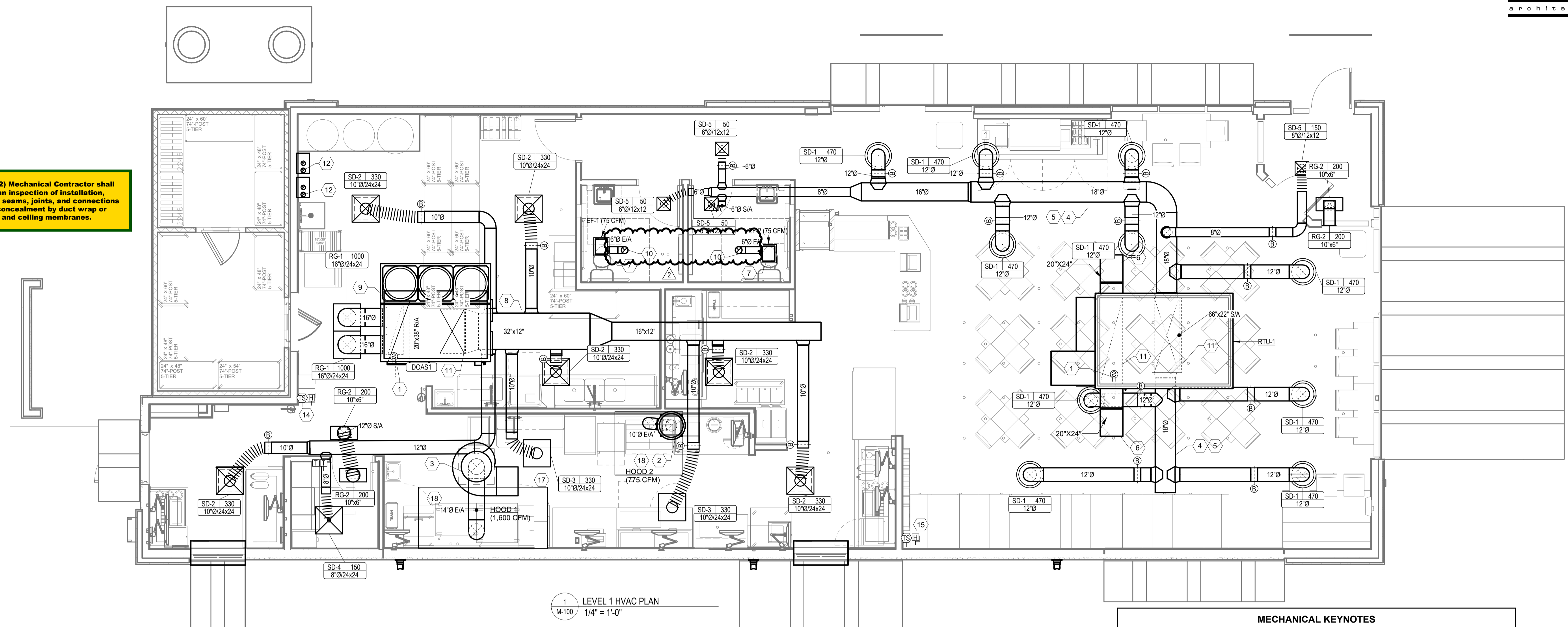

1 LEVEL 1 HVAC PLAN
1/4" = 1'-0"

OUTDOOR AIR CALCULATIONS

UNIT	Area (sqft)	OCCUPANCY CLASSIFICATION	Occupant Density #/1000 sqft	People outdoor airflow rate in breathing zone, (Rp) cfm/person	Area outdoor airflow rate in breathing zone, (Ria) cfm/sqft	Exhaust airflow rate cfm/sqft	Breathing zone outdoor airflow (Vbz)	Zone air distribution effectiveness (Ez)	Zone outdoor airflow (cfm)
RTU-1	1100	Dining rooms	70	7.5	0.18		776	0.8	969
	150	Corridors	0	0	0.06		9	0.8	11
									Total 981

AIR BALANCE SCHEDULE

SUPPLY AIR UNIT	OUTSIDE AIRFLOW (CFM)	RETURN AIRFLOW (CFM)	SUPPLY AIRFLOW (CFM)	OA/SA %	EXHAUST AIR UNIT	EXHAUST AIRFLOW (CFM)
RTU-1	981	4,019	5,000	19.6%	KEF-1	1600
DOAS-1	2,650	0	2,650	100.0%	KEF-2	775
					EF-1, EF-2	150
TOTAL	3,631	4,019	7,650	47.46%	TOTAL	2,525
					RESULTING BUILDING PRESSURIZATION	1,106 CFM

THE BUILDING HVAC SYSTEM SHALL BE BALANCED BY NATIONAL TAB HIRED BY THE OWNER. CONTACT Dan Hertenstein - National TAB at: 816-215-1593 - DAN@NATIONALTAB.COM

THE RTU SUPPLY FANS SHALL OPERATE IN SINGLE ZONE VAV MODE WITH 2 STAGES OF FAN CONTROL. LOW SPEED SHALL BE USED DURING PERIODS OF LOW COOLING LOAD AND VENTILATION ONLY OPERATION PER 2018 IECC REQUIREMENTS.

THE ECONOMIZER DAMPERS SHALL HAVE TWO POSITIONS DEPENDENT ON THE FAN SPEED TO MAINTAIN CONSTANT OUTDOOR AIR VOLUME AND BUILDING PRESSURE. REFER TO THE BUILDING AIR BALANCE SCHEDULE ON SHEET M-200.

THE UNIT SHALL HAVE ITS FRESH AIR HEATING OPTION ENABLED TO HEAT VENTILATION AIR TO A NEUTRAL VALUE DURING COLD WEATHER OPERATION. REFER TO THE MANUFACTURERS PROGRAMMING DOCUMENTATION FOR SETUP INSTRUCTIONS.

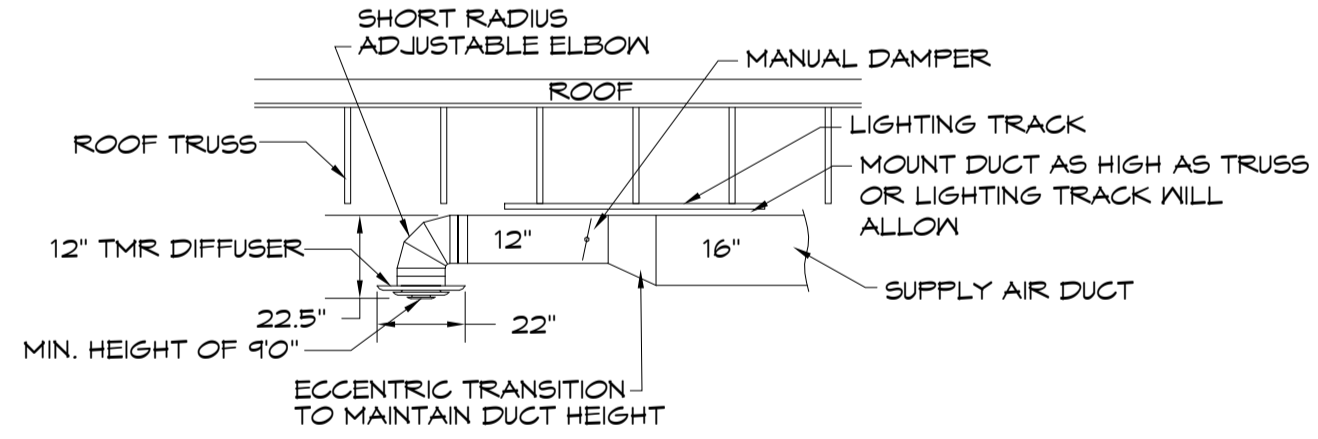

2 DINING ROOM DIFFUSER DETAIL
NO SCALE

MECHANICAL KEYNOTES

- LOCATION OF FACTORY DUCT MOUNTED SMOKE DETECTOR IN RETURN OF RTU. PROVIDE REMOTE ENUNCIATOR AUDIOVISUAL. VERIFY LOCATION WITH FIRE MARSHAL PRIOR TO INSTALLATION. REFER TO SPEC SHEET MP0 FOR ADDITIONAL INFORMATION.
- TRANSITION AND CONNECT 10" DIAMETER GREASE DUCT TO EXHAUST HOOD. ROUTE DUCT UP AND CONNECT TO EXHAUST FAN. OFFSET AS NECESSARY TO MISS ROOF STRUCTURE, AND TO MAINTAIN 10'-0" CLEARANCE FROM ALL OUTDOOR AIR INTAKES AND 5'-0" FROM PARAPET WALLS. ALL GREASE DUCT IS TO BE INSTALLED WITH DUCT WRAP AS DETAILED AND PER THE MANUFACTURERS REQUIREMENTS FOR 0" CLEARANCE TO COMBUSTIBLES. REFER TO ROOF PLAN M-101 FOR CONTINUATION.
- TRANSITION AND CONNECT 14" DIAMETER GREASE DUCT TO EXHAUST HOOD. ROUTE DUCT UP AND CONNECT TO EXHAUST FAN. OFFSET AS NECESSARY TO MISS ROOF STRUCTURE, AND TO MAINTAIN 10'-0" CLEARANCE FROM ALL OUTDOOR AIR INTAKES AND 5'-0" FROM PARAPET WALLS. ALL GREASE DUCT IS TO BE INSTALLED WITH DUCT WRAP AND ACCESS DOORS AS DETAILED AND PER THE MANUFACTURERS REQUIREMENTS FOR 0" CLEARANCE TO COMBUSTIBLES. REFER TO ROOF PLAN M-101 FOR CONTINUATION.
- COORDINATE DUCT ROUTING WITH LIGHTING. REFER TO SHEET E200.
- EXPOSED DUCTWORK SHALL BE OF PAINTLOCK CONSTRUCTION AND PAINTED PER THE DIRECTION OF ARCHITECT.
- RETURN AIR DUCT LOCATED BETWEEN ROOF TRUSSES. OPEN END OF DUCTWORK TURNED UP TOWARD STRUCTURE WITH A MINIMUM 9" CLEARANCE TO DECK.
- SUPPORT EXHAUST FAN FROM STRUCTURE AS REQUIRED BY THE MANUFACTURER.
- COORDINATE WITH STRUCTURAL TO BLOCK OUT JOISTS AS REQUIRED TO RUN DUCT THROUGH THE STRUCTURE. RETURN DUCT TO BE ROUTED THROUGH JOISTS, AS HIGH AS STRUCTURE WILL ALLOW.
- ROUTE 6" EXHAUST DUCT UP THROUGH ROOF TO ROOF CAP. MAINTAIN 10'-0" CLEARANCE TO ALL OUTDOOR AIR INTAKES. SEAL PENETRATION WEATHERTIGHT.
- TRANSITION AND CONNECT DUCTWORK TO DUCT DROP WITH FLEXIBLE CONNECTION. COORDINATE WITH STRUCTURAL PLAN AND OFFSET DUCTWORK AS NECESSARY TO FIT BETWEEN JOISTS. REFER TO ROOF PLAN M-101 FOR CONTINUATION.
- PROVIDE 3" PVC FLUE AND COMBUSTION AIR INTAKE PIPE FOR HOT WATER HEATER THROUGH ROOF. PROVIDE MANUFACTURERS TERMINATION KIT. SEAL PENETRATION WEATHERTIGHT. VERIFY 10'-0" CLEARANCE FROM ALL OUTDOOR AIR INTAKES.
- LOCATION OF DOAS TEMPERATURE SENSOR AND HUMIDISTAT MOUNTED AT 7' AFF.
- LOCATION OF REMOTE TEMPERATURE AND HUMIDITY SENSOR FOR RTU. INSTALL AT 9' AFF.
- HOOD SHALL BE PROVIDED WITH FACTORY PRE-WIRE PACKAGE AND A PRE-ENGINEERED UL-300 FIRE SUPPRESSION SYSTEM. SEE HOOD DRAWINGS FOR DETAILS.
- EXHAUST HOOD PROVIDED BY OTHERS. INSTALLED BY THIS CONTRACTOR PER THE MANUFACTURERS INSTRUCTIONS.

a new restaurant for:
Lot 6A MacArthur Dr
Alexandria, LA 71301

date
07/28/2023
drawn by
Author
checked by
Checker
revisions
12/06/2023

sheet number
M-100

drawing type
PROTOTYPE DOCUMENTS
project number
23472

This drawing has been prepared by the Engineer, or under his supervision. This drawing is provided as an instrument of service by the Designer/Engineer and is intended for use on the project only. Pursuant to the Architectural Works Copyright Protection Act of 1990, all drawings, specifications, ideas and designs, including the overall form, arrangement and composition of graphic and electronic appearing herein, constitute the original, copyrighted work of the Designer/Engineer. Any reproduction, use, or disclosure of information contained herein without prior written consent of the Engineer is strictly prohibited. © 2023 BC Engineers, Inc.



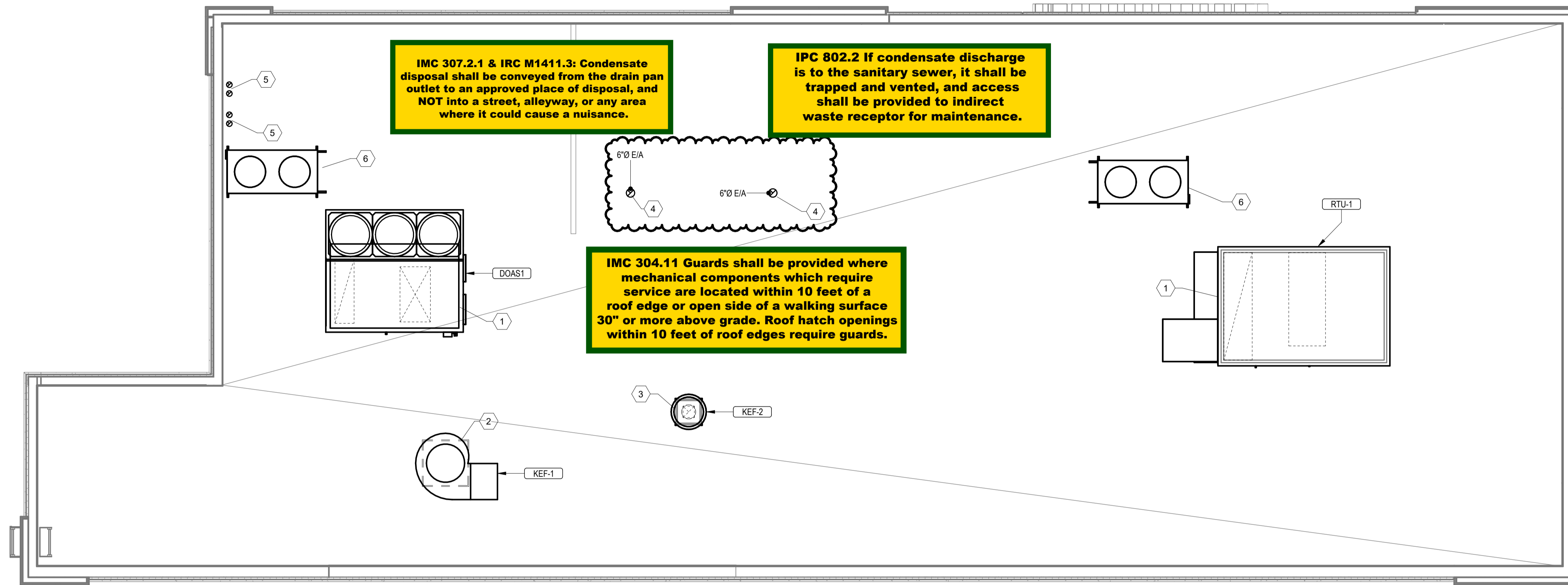
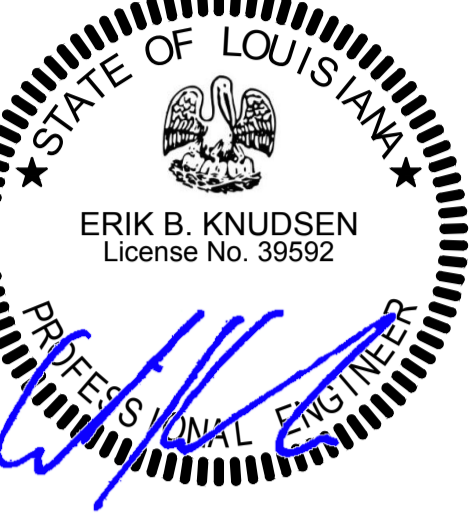

IMC 307.2.1 & IRC M1411.3: Condensate disposal shall be conveyed from the drain pan outlet to an approved place of disposal, and **NOT** into a street, alleyway, or any area where it could cause a nuisance.

IPC 802.2 If condensate discharge is to the sanitary sewer, it shall be trapped and vented, and access shall be provided to indirect waste receptor for maintenance.

IMC 304.11 Guards shall be provided where mechanical components which require service are located within 10 feet of a roof edge or open side of a walking surface 30" or more above grade. Roof hatch openings within 10 feet of roof edges require guards.

1
M-101
MECHANICAL ROOF PLAN
1/4" = 1'-0"

MECHANICAL KEYNOTES	
1	PROVIDE RTU/DOAS IN LOCATION AS SHOWN ON PLANS. COORDINATE EXACT RTU LOCATION AND DUCT DROPS WITH STRUCTURAL TRUSS LAYOUT. MAINTAIN MINIMUM 10'-0" CLEARANCE BETWEEN OUTDOOR AIR INTAKES AND EXHAUST TERMINATIONS.
2	PROVIDE TYPE I EXHAUST FAN IN LOCATION AS SHOWN ON PLANS. CONNECT 10" DIAMETER EXHAUST DUCT FROM EXHAUST HOOD UP TO KEF-1 ON ROOF. COORDINATE EXHAUST DUCT ROUTING WITH STRUCTURAL TRUSS LAYOUT.
3	PROVIDE TYPE I EXHAUST FAN IN LOCATION AS SHOWN ON PLANS. CONNECT 6" DIAMETER EXHAUST DUCT FROM EXHAUST HOOD UP TO KEF-2 ON ROOF. COORDINATE EXHAUST DUCT ROUTING WITH STRUCTURAL TRUSS LAYOUT.
4	6" EXHAUST DUCT ROUTED TO ROOF CAP AS REQUIRED.
5	PROVIDE MANUFACTURER'S CONCENTRIC TERMINATION VENT KIT SERVING HOT WATER HEATER BELOW. INSTALL IN STRICT ACCORDANCE WITH MANUFACTURER'S REQUIREMENTS. ENSURE AT LEAST 10'-0" DISTANCE BETWEEN OUTDOOR AIR INTAKES.
6	MOUNT CONDENSING UNIT ON ROOF AS DETAILED AND AS REQUIRED BY THE MANUFACTURER. CONNECT REFRIGERANT PIPING TO EVAP COIL AS REQUIRED BY THE MANUFACTURER. SEE SHEET M200 FOR MOUNTING DETAIL.

This drawing has been prepared by the Engineer, or under his supervision. This drawing is provided as an instrument of service by the Designer/Engineer and is intended for use on this project only. Pursuant to the Architectural Works Copyright Protection Act of 1990, all drawings, specifications, ideas and designs, including the overall form, arrangement and composition of graphic elements appearing herein, constitute the original, copyrighted work of the Designer/Engineer. Any reproduction, use, or disclosure of information contained herein without prior written consent of the Engineer is strictly prohibited. © 2023 BC Engineers, Inc.



5720 Reeder Shawnee, KS 66203 (913)262-1772

a new restaurant for:
Lot 6A MacArthur Dr
Alexandria, LA 71301

date
07/28/2023
drawn by
Author
checked by
Checker
revisions
12/06/2023

2

sheet number
M-101

drawing type
PROTOTYPE DOCUMENTS
project number
23472



ROOFTOP UNIT SCHEDULE																								
MARK	MANUFACTURER	MODEL NO.	NOM TONS	EVAP CFM	EXT. STATIC P. IN. WG.	COOLING				HEATING (GAS)			ELECTRICAL				TOTAL WEIGHT (LBS)	NOTES						
						COOLING STAGES	TOTAL	SENSIBLE	AMB	EVAP.EAT DB/WB	HOT GAS REHEAT	INPUT	OUTPUT	HEATING STAGES	VOLT/PH/Hz	BLOWER MOTOR			POWER EXHAUST	MCA	MCCP	SUPPLY FAN TYPE	MINIMUM OUTDOOR AIR	IEER
RTU-1	Trane	YSJ-150--	12.5	5000 CFM	1.000	3	149000 Btu/h	105000 Btu/h	105.0 °F	80.0 °F / 67.0 °F	Yes	240000 Btu/h	202500 Btu/h	3	208 V / 3 / 60 Hz	3.00 hp	Yes	65.0 A	90.0 A	VFD	981 CFM	14	2046 lb	1-8

ALTERNATE ROOFTOP UNIT MANUFACTURER																								
MARK	MANUFACTURER	MODEL NO.	NOM TONS	EVAP CFM	EXT. STATIC P. IN. WG.	COOLING				HEATING (GAS)			ELECTRICAL				TOTAL WEIGHT (LBS)	NOTES						
						COOLING STAGES	TOTAL	SENSIBLE	AMB	EVAP.EAT DB/WB	HOT GAS REHEAT	INPUT	OUTPUT	HEATING STAGES	VOLT/PH/Hz	BLOWER MOTOR			POWER EXHAUST	MCA	MCCP	SUPPLY FAN TYPE	MINIMUM OUTDOOR AIR	IEER
RTU-1	Carrier	48HCFE14	12.5	5000 CFM	1.000	2	154800 Btu/h	116100 Btu/h	105.0 °F	80.0 °F / 67.0 °F	Yes	240000 Btu/h	192000 Btu/h	2	208 V / 3 / 60 Hz	5.00 hp	Yes	71.0 A	90.0 A	VFD	981 CFM	13.5	1363 lb	1-8
RTU-1	YORK	ZJ15024D	12.5	5000 CFM	1.000	2	154800 Btu/h	116100 Btu/h	105.0 °F	80.0 °F / 67.0 °F	Yes	240000 Btu/h	192000 Btu/h	2	208 V / 3 / 60 Hz	5.00 hp	Yes	71.0 A	90.0 A	VFD	981 CFM	13.5	1363 lb	1-8

NOTES:

- PROVIDE DIGITAL CONTROLS, HIGH PERFORMANCE WITH FDD OUTDOOR AIR ECONOMIZER WITH DRY BULB CONTROL, SINGLE ZONE VAV (MSAV), BAROMETRIC RELIEF DAMPER, TIME DELAY ON COMPRESSOR RE-START, CRANKCASE HEATER, BAROMETRIC RELIEF DAMPER, DRAIN PAN OVERFLOW SWITCH, DISCHARGE AIR TEMPERATURE SENSING, HINGED ACCESS DOORS, AND STANDARD COOLING DOWN TO 0°F FOR EACH UNIT. OUTDOOR AIR DAMPER TO FULLY CLOSE W/ FAN SHUTDOWN FOR ALL UNITS.
- EXTERNAL STATIC PRESSURE LISTED REPRESENTS STATIC PRESSURE REQUIRED FOR DUCTWORK AND DIFFUSERS OUTSIDE THE HVAC UNIT COMPLETELY INDEPENDENT OF ANY PRESSURE DROP THROUGH THE HVAC EQUIPMENT INCLUDING BUT NOT LIMITED TO FILTERS, COILS AND ECONOMIZERS. THE FAN AND MOTOR SHALL BE SIZED APPROPRIATELY TO MEET THIS DEFINITION OF EXTERNAL STATIC PRESSURE.
- PROVIDE COMMERCIAL 7-DAY PROGRAMMABLE HEAT/COOL/AUTO CHANGE-OVER THERMOSTAT WITH ECONOMIZER OUTPUT AND REMOTE, TEMPERATURE AND HUMIDITY SENSOR FOR EACH UNIT (HONEYWELL VISION PRO 8000 OR EQUAL). ECONOMIZER/OUTDOOR AIR DAMPER IS TO CLOSE DURING UNOCCUPIED HOURS.
- PROVIDE 14" HIGH (AT LOWEST POINT) PRE-FABRICATED INSULATED ROOF CURB.
- PROVIDE HAIL GUARDS FOR EACH UNIT.
- PROVIDE FACTORY INSTALLED UNIT MOUNTED CIRCUIT BREAKERS.
- MECHANICAL CONTRACTOR SHOULD PROVIDE ALL NEW FILTERS ON DAY OF TURN-OVER.
- PROVIDE HOT GAS REHEAT FOR HUMIDITY CONTROL AND ALL ASSOCIATED ACCESSORY COMPONENTS.

NATIONAL ACCOUNT INFORMATION

FREDDY'S FROZEN GUSTARD HAS NATIONAL ACCOUNT AGREEMENTS FOR ROOF TOP UNITS WITH TRANE, CARRIER, AND YORK. NO ALTERNATE MANUFACTURERS ARE ALLOWED.

FOR TRANE EQUIPMENT EQUAL TO THE UNITS SPECIFIED CONTACT:
JUSTIN BARNES, TRANE ACCOUNT MANAGER - NATIONAL ACCOUNTS, (303) 228-2896
JDBARNES@TRANE.COM

FOR CARRIER EQUIPMENT CONTACT:
TERRI BURNS, ACCOUNT ORDER MANAGER, (915) 432-3653
nationalaccounts@carrier.com

FOR YORK EQUIPMENT CONTACT:
DAVID WALMSEY, ACCOUNT ORDER MANAGER, (774)-573-5125
david.walmsey@jcl.com

FAN SCHEDULE													
ID	LOCATION	MANUFACTURER	MODEL NO.	TYPE	DESIGN AIRFLOW		ESP	FAN			VOLT	PH	REMARKS
					CFM	SP		DRIVE TYPE	POWER	RPM			
EF-1	Ceiling	Greenheck	SP-A200-390	Premium (Constant Cfm)	75 CFM	0.250	Direct	0.08 hp	900	Yes	0 V	1	SEE NOTE 1.
EF-2	Ceiling	Greenheck	SP-A200-390	Premium (Constant Cfm)	75 CFM	0.250	Direct	0.08 hp	900	Yes	0 V	1	SEE NOTE 1.

NOTES: 1. PROVIDE CEILING GRILLE, INTEGRAL BACKDRAFT DAMPER, AND ROOF CAP.

GRILLES, REGISTERS AND DIFFUSERS SCHEDULE									
ID	MANUFACTURER	MODEL	MATERIAL	FINISH	NECK			NOTES	
					SIZE	WIDTH	HEIGHT		
RG-1	AMER. LOUVER CO	STRATUS	Aluminum	White Enamel	16"	0"	0"	SEE NOTE 1.	
RG-2	Titus	350RL	Steel	White Enamel	0"	10"	6"		
SD-1	Titus	TMR	Steel	White Enamel	12"	0"	0"	FIELD PREP FOR PAINTING	
SD-2	Titus	TMS-AA	Aluminum	WHITE ENAMEL	10"	0"	0"		
SD-3	Titus	PAR	Steel	White Enamel	10"	0"	0"	RETURN - NO DEFLECTOR	
SD-4	Titus	T35Q-4	Steel	WHITE ENAMEL	8"	0"	0"	THERMAL VAV DIFFUSER	
SD-5	Titus	TMS	Steel	White Enamel	<varies>	0"	0"	WITH O.B. DAMPER AND TRM KIT	

NOTES: 1. RETURN GRILLE TO BE PLASTIC FILTER RETURN, FILTER TO BE AMERICAN AIR FILTER (AAF) FRONTLINE GREEN 1" WITH AAF AMERIFRAME SIZE 20X20X1.

FIRE RATED ENCLOSURE - GREASE DUCTS

- THERMAL CERAMICS FIREMASTER FASTWRAP XL IS TESTED TO ASTM E2336 AND UL LISTED PER HNK1.G18 TO PROVIDE ZERO CLEARANCE TO COMBUSTIBLES AND TO PROVIDE A 1- OR 2- HOUR ENCLOSURE. THROUGH PENETRATIONS FIRESTOP SYSTEMS ARE TESTED IN ACCORDANCE WITH ASTM E 814 (UL 1479). ICC-ES APPROVAL PER REPORT ESR 2213 OR ESR 2832.
- COMPLIANT TO THE FOLLOWING CODES:
NFPA 96
INTERNATIONAL MECHANICAL CODES
UNIFORM MECHANICAL CODE
CALIFORNIA MECHANICAL CODE
- INSULATION APPLIED IN TWO LAYERS WITH TIGHT COMPRESSION JOINT ON BOTH LAYERS AT ALL JOINTS.
- MINIMUM 16 GAUGE CARBON STEEL (OR 18 GAGE STAINLESS STEEL) RECTANGULAR OR ROUND GREASE EXHAUST DUCT
- INSTALL UL LISTED AND LIQUID TIGHT THERMAL CERAMICS FASTDOOR XL ACCESS DOORS AT ALL CHANGES IN DIRECTION AND AT MINIMUM EVERY 20 FT ON HORIZONTAL RUNS.
- SUPPORT HANGER SYSTEMS DO NOT NEED TO BE WRAPPED PROVIDED THE HANGER RODS ARE MINIMUM OF 3/8 IN. DIAMETER AND SUPPORTS ARE MINIMUM 2 X 2 X 1/8 IN. STEEL ANGLE OR SMACNA EQUIVALENT SUPPORT SYSTEM.
- THERMAL CERAMICS DUCT WRAP SHALL BE INSTALLED DIRECTLY ONTO THE DUCT AND APPLIED FROM THE HOOD CONNECTION TO THE CONNECTION TO THE FAN.
- THERMAL CERAMICS DUCT ENCLOSURE SYSTEM SHALL BE INSTALLED IN STRICT ACCORDANCE WITH MANUFACTURERS INSTRUCTIONS AND UL LISTINGS.

Morgan ThermalCeramics
P.O. Box 923
Augusta, Georgia 30903-0923
Phone: (706) 560-4038

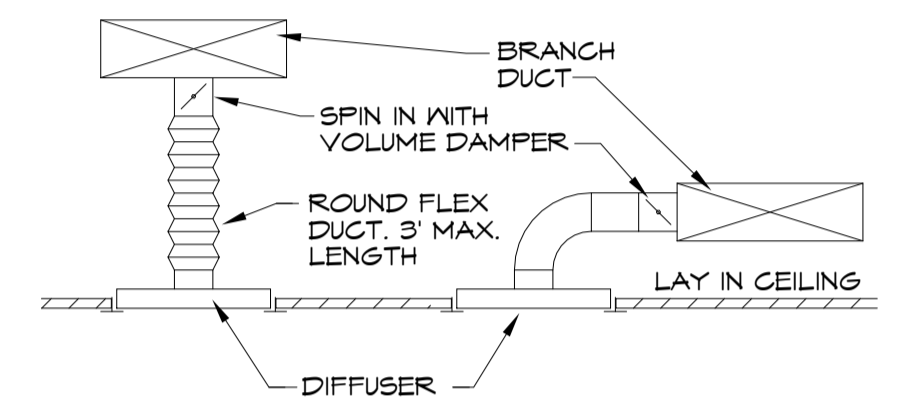

6 DIFFUSER DETAIL
NO SCALE

IMC 107.2(2) Mechanical Contractor shall call for an inspection of installation, including all seams, joints, and connections prior to concealment by duct wrap or wall and ceiling membranes.

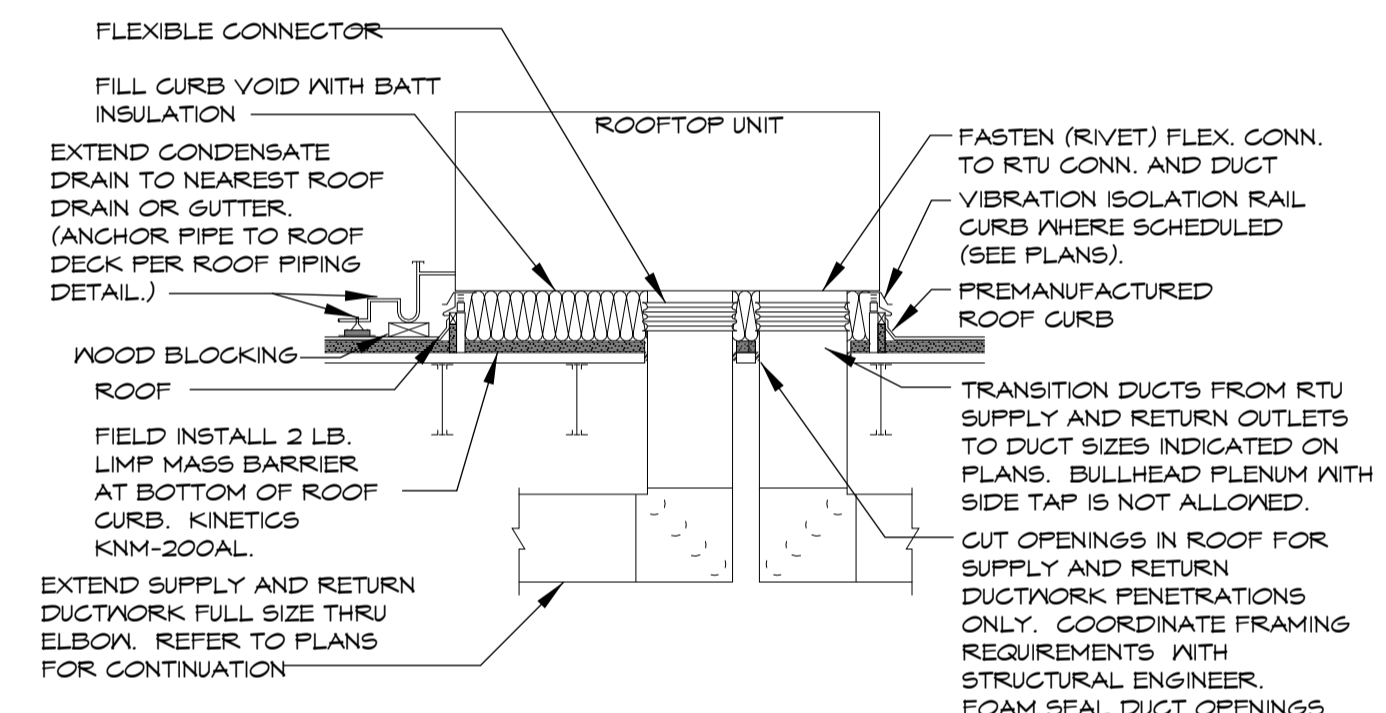

7 DOWNFLOW ROOFTOP UNIT DETAIL
NO SCALE

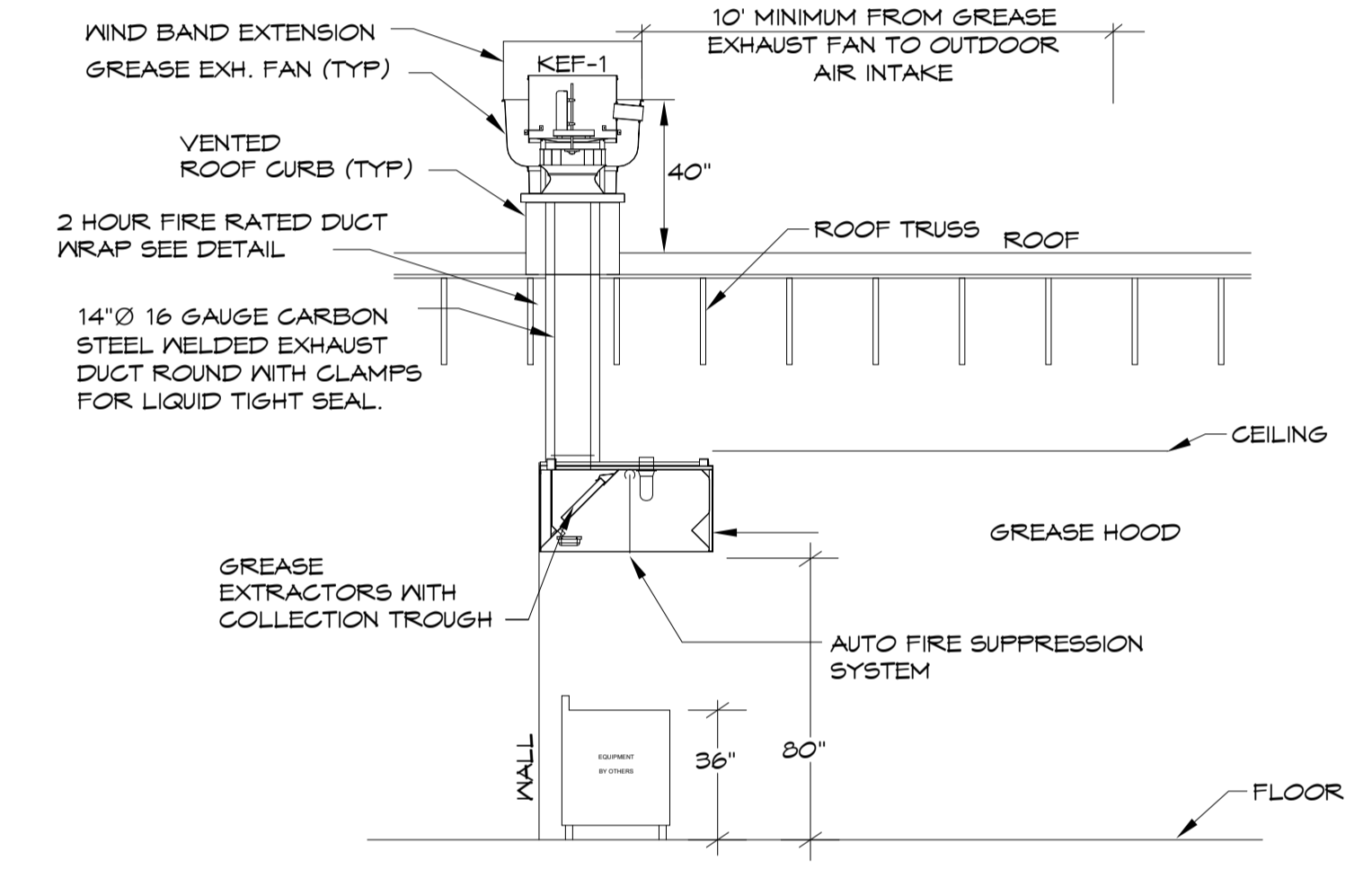

4 GREASE HOOD DETAIL
NO SCALE

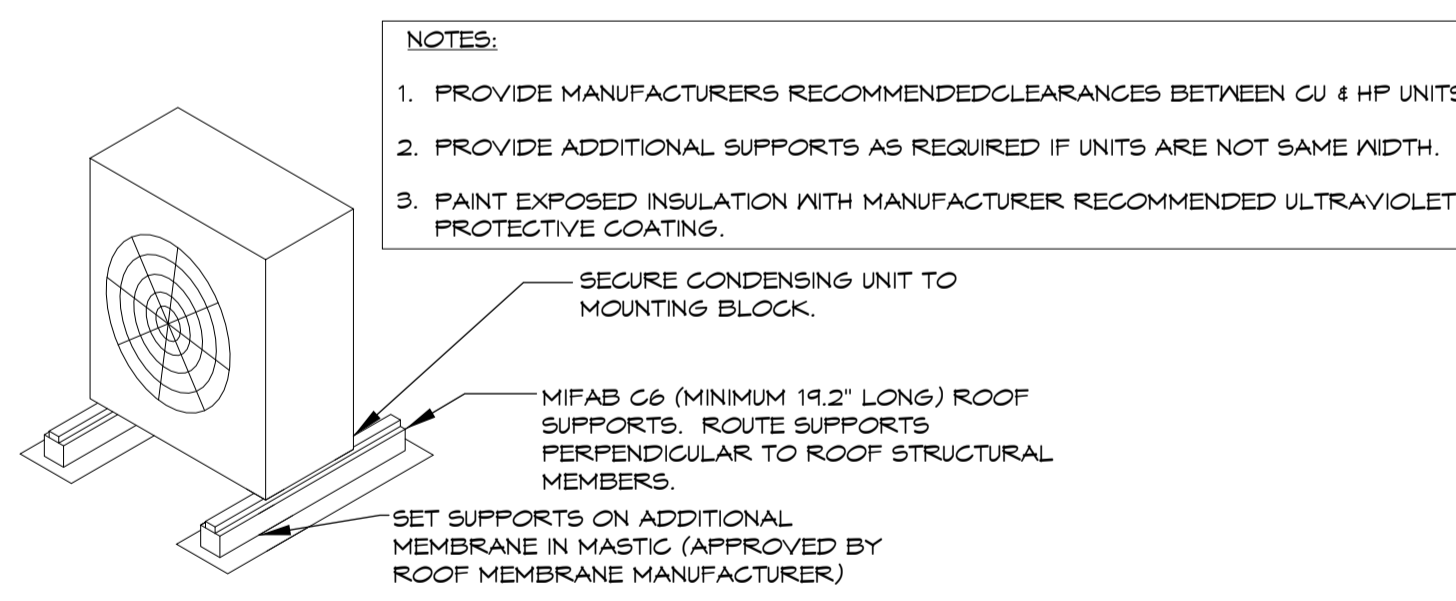

5 ROOFTOP CONDENSING UNIT DETAIL
NO SCALE

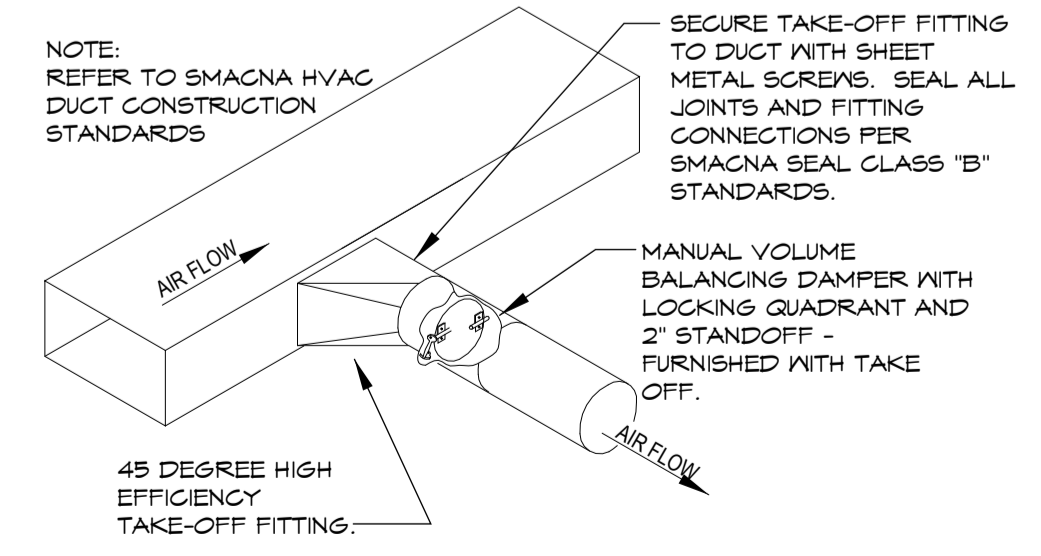

8 ROUND DUCT TAKE OFF DETAIL
NO SCALE

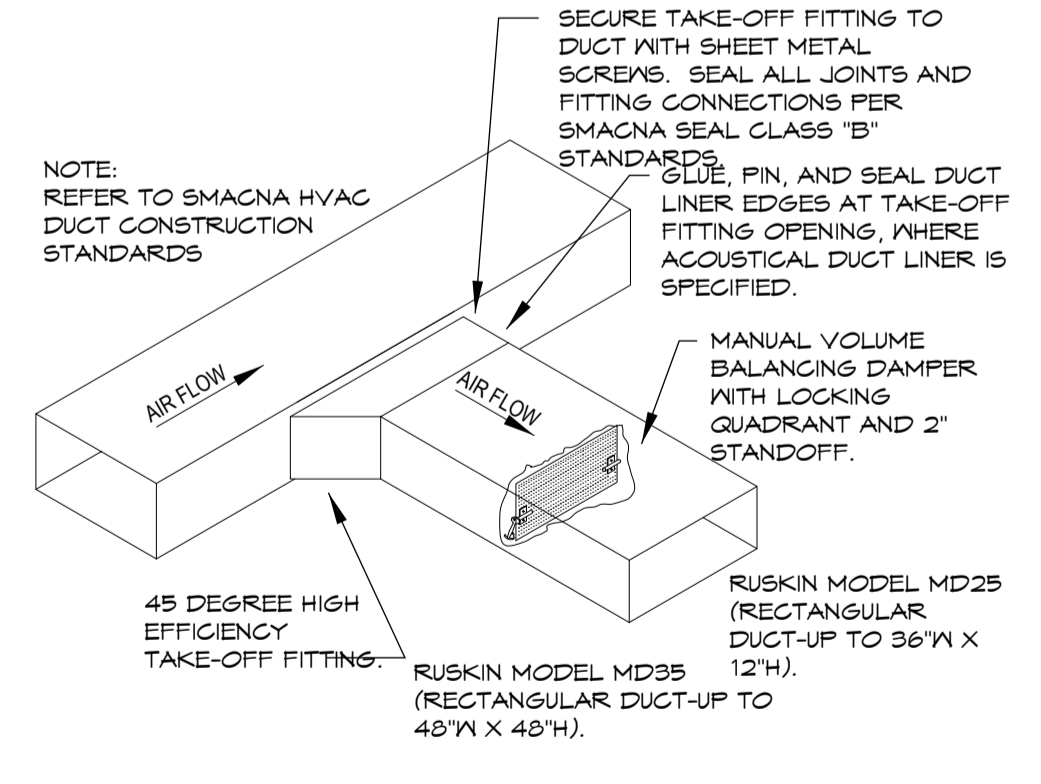

9 RECTANGULAR DUCT TAKE OFF DETAIL
NO SCALE

a new restaurant for:
Lot 6A MacArthur Dr
Alexandria, LA 71301

date
07/28/2023
drawn by
Author
checked by
Checker
revisions

sheet number
M-200

This drawing has been prepared by the Engineer, or under his supervision. This drawing is provided as an instrument of service by the Designer/Engineer and is intended for use on the project only. Pursuant to the Architectural Works Copyright Protection Act of 1990, all drawings, specifications, ideas and designs, including those saved from, amended and/or composed of, shall be deemed to be the property of the Designer/Engineer. Any reproduction, use, or disclosure of information contained herein without prior written consent of the Engineer is strictly prohibited. © 2023 BC Engineers, Inc.

BC ENGINEERS INCORPORATED
5720 Reeder Shawnee, KS 66203 (913)262-1772

drawing type
PROTOTYPE DOCUMENTS
project number
23472

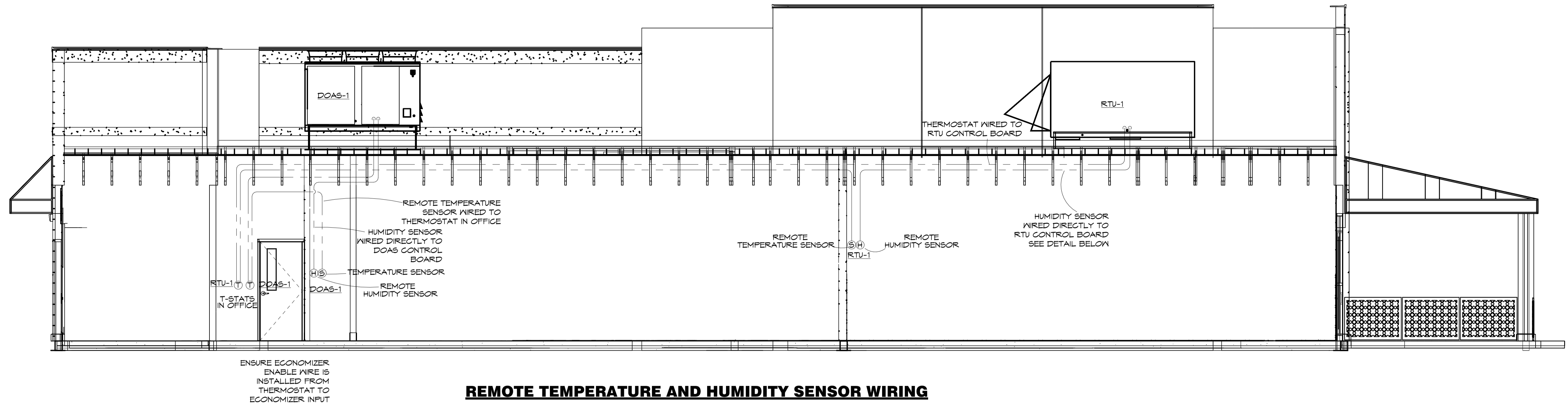

REMOTE TEMPERATURE AND HUMIDITY SENSOR WIRING

ALL LOW VOLTAGE WIRING FOR THE HVAC SYSTEM IS TO BE PROVIDED AND INSTALLED BY THE HVAC CONTRACTOR.

Installation

DC Conductors

Table 11. Zone sensor module wiring

Distance from Unit to Control	Recommended Wire Size
0 - 150 feet	22 gauge
0 - 45.7 m	0.33 mm ²
151 - 240 feet	20 gauge
46 - 73.1 m	0.50 mm ²
241 - 385 feet	18 gauge
73.5 - 117.3 m	0.75 mm ²
386 - 610 feet	16 gauge
117.7 - 185.9 m	1.3 mm ²
611 - 970 feet	14 gauge
186.2 - 295.7 m	2.0 mm ²

Figure 58. Typical field wiring diagrams for electromechanical

ELECTRO MECHANICAL THERMOSTAT
GAS / ELECTRIC UNITS

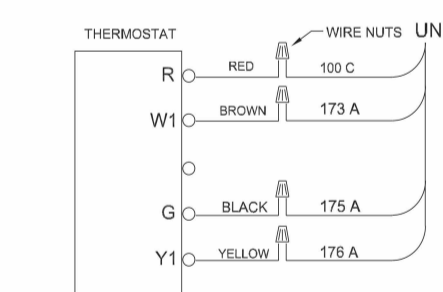
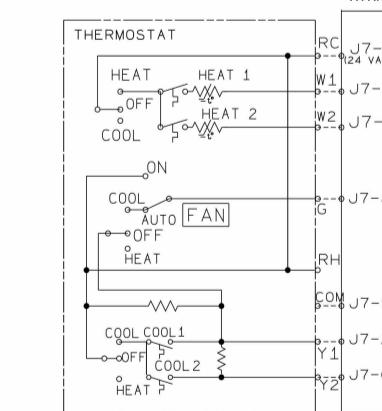

Figure 59. ReliaTel™ conventional thermostat field wiring diagrams(a)



(a) Not compatible with VAV units.

Figure 60. ReliaTel™ options module (RTOM board)

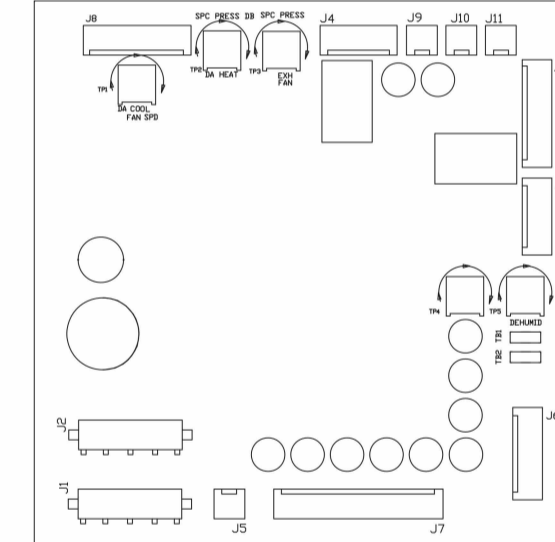

Figure 61. ReliaTel™ relative humidity sensor (dehumidification option)

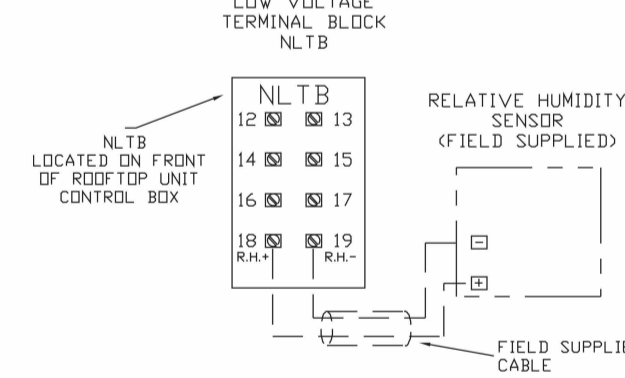
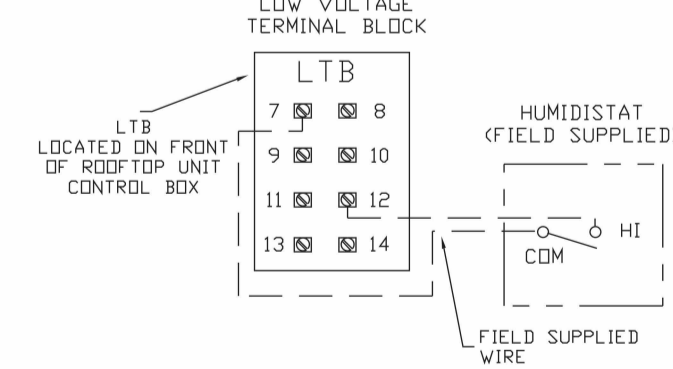

Figure 62. ReliaTel™ humidistat (dehumidification option)



TRANE HUMIDITY SENSOR WIRING

40

RT-SVX21YEN

FOR GENERAL INFORMATION ONLY
REFER TO MANUFACTURER'S INSTALLATION INSTRUCTIONS
PROVIDED WITH THE EQUIPMENT FOR EXACT INSTALLATION INSTRUCTIONS AND REQUIREMENTS.

This drawing has been prepared by the Engineer, or under his supervision. This drawing is provided as an instrument of service by the Designer/Engineer and is intended for use on this project only. Pursuant to the Architectural Works Copyright Protection Act of 1990, all drawings, specifications, ideas and designs, including the overall form, arrangement and composition of graphic elements appearing herein, constitute the original, copyrighted work of the Designer/Engineer. Any reproduction, use, or disclosure of information contained herein without prior written consent of the Engineer is strictly prohibited. © 2023 BC Engineers, Inc.

BC ENGINEERS INCORPORATED

5720 Reeder Shawnee, KS 66203 (913)262-1772

a new restaurant for:
Lot 6A MacArthur Dr
Alexandria, LA 71301

date
07/28/2023
drawn by
Author
checked by
Checker
revisions

sheet number
M-201

drawing type
PROTOTYPE DOCUMENTS
project number
23472

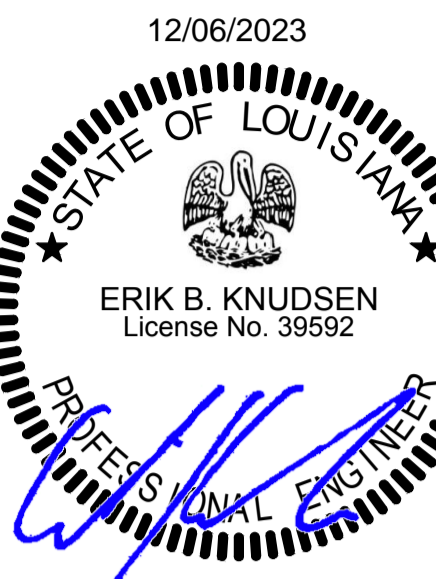

12/06/2023

STATE OF LOUISIANA
ERIK B. KNUDSEN
License No. 39592
PROFESSIONAL ENGINEER

ND-2 HANGING ANGLE DETAIL

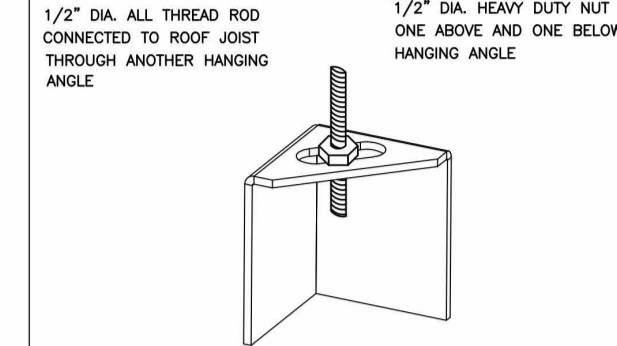

ROD AND NUTS TO BE SUPPLIED BY INSTALLING CONTRACTOR. HANGING ANGLE IS PRE-PUNCHED AT FACTORY.

HANGING ANGLE LOCATIONS

HOOD STYLE	DIM FROM REAR	DIM FROM FRONT (24" H)	DIM FROM FRONT (30" H)
CANOPY ND2	4.166"	2.246"	2.246"
ND2-PSP-F	4.166"	2.246"	2.246"
BACKSHELF BO-2	4.166"	2.246"	-
VHB/VHB-G	36"x36"	42"x42"	48"x48"
FRONT/BACK DIMS BY SIZE	2.246"	2.246"	2.246"

CALCULATIONS UTILIZED

EXHAUST CFM=LENGTH OF HOOD X CFM/LIN.FT. (L40)
SUPPLY CFM=EXHAUST CFM X PERCENTAGE REQUIRED
TOTAL DUCT AREA=144 X CFM / FPM(C)
DUCT LENGTH= TOTAL DUCT AREA / DUCT VELOCITY
CAPTIVE-AIRE DUCT CONNECTION SIZES ARE CALCULATED USING AN EXHAUST VELOCITY OF 1500-1800 FPM AND A SUPPLY VELOCITY OF 300-400 FPM.

BUILDING CODES

CAPTIVE-AIRE HOODS ARE BUILT IN COMPLIANCE WITH:

 LISTED UNDER ETL File number 3054804-001/002

CLEARANCE TO COMBUSTIBLES

MATERIAL	CLEARANCE REDUCTION SYSTEM
NON-COMBUSTIBLE	NONE REQUIRED
LIMITED-COMBUSTIBLE	3" UNINSULATED STANDOFF
COMBUSTIBLE	1" INSULATED STANDOFF

GENERAL NOTES

- ALL ELECTRICAL "FIELD" CONNECTIONS AND RELATED INTERCONNECTIONS BY ELECTRICAL CONTRACTORS.
- ALL PLUMBING "FIELD" CONNECTIONS AND RELATED INTERCONNECTIONS BY PLUMBING CONTRACTORS.
- HANGING BRACKETS LOCATED AND RELATED AS SHOWN ON PLANS. ALL OTHER HANGER MATERIALS PROVIDED BY INSTALLING CONTRACTORS.
- ALL CONNECTIONS FROM CAPTIVE-AIRE DUCT PER MECHANICAL CONTRACTOR'S PLANS.
- COOKING EQUIPMENT TO SHUT OFF IN EVENT OF FIRE.
- EXHAUST FANS TO TURN ON IN EVENT OF FIRE.
- ALL LIGHTS FIXTURE SHOWN INSTALLED BY CAPTIVE-AIRE ARE FACTORY PROVIDED. INTERCONNECTIONS BETWEEN HOODS AND TO SWITCHES BY ELECTRICAL CONTRACTORS.
- LAMPS FOR LIGHT FIXTURES BY INSTALLING CONTRACTORS.
- SEISMIC RESTRAINTS ARE RESPONSIBILITY OF INSTALLING CONTRACTORS.
- INSTALLING CONTRACTORS ASSUME ALL RELATED RESPONSIBILITY FOR VERIFICATION OF DIMENSIONAL DATA CONTAINED ON THESE DOCUMENTS FOR ACCURACY, INTEGRATION, AND ADMINISTRATION OF CODE REQUIREMENTS IN EFFECT PRIOR TO ANY RELEASE FOR PRODUCTION OF EQUIPMENT SHOWN.
- KITCHEN HOODS MUST BE BALANCED WITH KITCHEN.
- KITCHEN SHALL BE NEGATIVE WITH RESPECT TO DINING AREA.
- RESTAURANT SHALL BE POSITIVE WITH RESPECT TO AMBIENT PRESSURE.

ADDITIONAL

- WRITTEN HOOD DIMENSIONS HAVE PRECEDENCE OVER SCALE.
- SIGNED AND "APPROVED" COPIES OF THIS DOCUMENT MUST BE RECEIVED BY THE FACTORY PRIOR TO COMMENCEMENT OF FABRICATION.

FILTER DETAIL

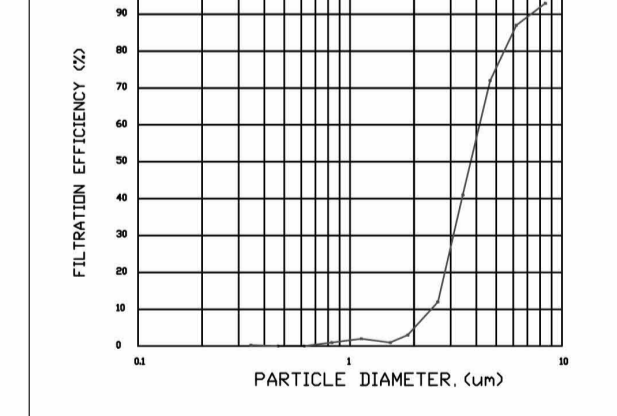

CaptiveAire Captrate Solo Filter
ETL Listed Grease Extracting Filter
Made From 430 Stainless Steel

HOOD INFORMATION -- JOB#5976146

HOOD NO	TAG	MODEL	MANUFACTURER	LENGTH	MAX COOKING TEMP	TYPE	APPLIANCE DUTY	DESIGN CFM/FT	TOTAL EXH CFM	EXHAUST SYSTEM	HOOD CONSTRUCTION	HOOD END TO END	HOOD FRONT	PATENT NUMBERS
1	ITEM 33A	5424 ND-2	CAPTIVEAIRE	6' 0"	450 DEG	1	MEDIUM	200	1600	1600	430 SS WHERE EXPOSED	ALDNE	FRONT	EXHAUST HOODS ND-2/BD-2/SND-2 (CANADA) - CA PATENT 2580435 C.
2	ITEM 33B	5424 ND-2	CAPTIVEAIRE	6' 0"	450 DEG	1	MEDIUM	155	775	775	430 SS WHERE EXPOSED	ALDNE	ALDNE	

HOOD INFORMATION

HOOD NO	TAG	TYPE	QTY	HEIGHT	LENGTH	EFFICIENCY @ 7 MICRONS	QTY	TYPE	WIRE GUARD	LOCATION	SIZE	UTIL. SYSTEM	ELECTRICAL	SWITCHES	FIRE HOOD SYSTEM	HOOD WEIGHT
1	ITEM 33A	CAPTIVATE SOLO FILTER	5	16"	16"	85% SEE FILTER SPEC.	2	RECESSED ROUND	NO	LEFT	18"x54"x24"		DCV-2011	1 LIGHT	NO	505 LBS
2	ITEM 33B	CAPTIVATE SOLO FILTER	3	16"	16"	85% SEE FILTER SPEC.	2	RECESSED ROUND	NO					1 FAN	NO	295 LBS

HOOD OPTIONS

HOOD NO	TAG	OPTION
1	ITEM 33A	FIELD WRAPPER 1800" HIGH FRONT, LEFT, RIGHT. LEFT QUARTER END PANEL 23" TOP WIDTH, 0" BOTTOM WIDTH, 23" HIGH 430 SS. RIGHT QUARTER END PANEL 23" TOP WIDTH, 0" BOTTOM WIDTH, 23" HIGH 430 SS. RISER SENSOR INSTALL 2IN DBL.
2	ITEM 33B	FIELD WRAPPER 1800" HIGH FRONT, LEFT, RIGHT. LEFT QUARTER END PANEL 23" TOP WIDTH, 0" BOTTOM WIDTH, 23" HIGH 430 SS. RIGHT QUARTER END PANEL 23" TOP WIDTH, 0" BOTTOM WIDTH, 23" HIGH 430 SS. RISER SENSOR INSTALL 6IN PLEN.

SPECIFICATION: CAPTRATE® GREASE-STOP® SOLO FILTER
 THE CAPTRATE GREASE-STOP SOLO FILTER IS A SINGLE-STAGE FILTER FEATURING A UNIQUE S-BAFFLE DESIGN IN CONJUNCTION WITH A SLOTTED REAR BAFFLE DESIGN TO DELIVER EXCEPTIONAL FILTRATION EFFICIENCY.
 FILTER IS STAINLESS STEEL CONSTRUCTION, AND SIZED TO FIT INTO STANDARD 2-INCH DEEP HOOD CHANNELS.
 UNITS SHALL INCLUDE STAINLESS STEEL HANDLES AND A FASTENING DEVICE TO SECURE THE TWO COMPONENTS WHEN ASSEMBLED.
 GREASE EXTRACTION EFFICIENCY PERFORMANCE SHALL REMOVE AT LEAST 70% OF GREASE PARTICLES FIVE MICRONS IN SIZE, AND 85% GREASE PARTICLES SEVEN MICRONS IN SIZE AND LARGER, WITH A CORRESPONDING PRESSURE DROP NOT TO EXCEED 1.0 INCHES "0" WATER GAUGE.
 THE CAPTRATE GREASE-STOP SOLO WAS TESTED TO ASTM STANDARD ASTM F2239-05 MANUFACTURER APPROVED FOR USE IN SOLID FUEL APPLICATIONS AS A SPARK ARRESTER.
 EFFICIENCY VS. PARTICLE DIAMETER



NSF #16.
NSF STANDARD #2.
UL STANDARD 904.
INT. MECH. CODE (CMC).
ULC-5645.

IMC 507.6 Hood Performance test shall be conducted upon completion of the installation of a ventilation system serving commercial cooking appliances to verify the rate of exhaust airflow required by 507.5, the makeup airflow required by 508, and proper operation specified in this chapter. Permit holder shall furnish necessary equipment required for the test.

IMC 508.1.1: Commercial Kitchen Makeup Air
The temperature difference between makeup air and air in the conditioned space shall not exceed 10 degrees F, except where the added heating & cooling loads of the makeup air do not exceed the capacity of HVAC system.

IMC 506.3.6 Grease duct systems and exhaust equipment serving Type 1 hood shall have a minimum 18" clearance to combustible construction and a minimum 3" clearance to non-combustible construction, where enclosure is not required by 506.3.11.

IMC 507.2.1: Type 1 hood is required where cooking appliances produce grease-laden vapors or smoke during operation. IMC 507.1.1 requires Type 1 hoods to automatically activate the exhaust fan whenever cooking operations, and shall activate not more than 15 minutes after the first appliance served by the hood has been turned on.

FOR QUESTIONS, CALL THE:
KANSAS CITY REGIONAL OFFICE
1126 SWIFT STREET, KANSAS CITY, MO 64116
PHONE: (816) 221-8575
FAX: (816) 221-8511

CUSTOMER APPROVAL TO MANUFACTURE:
 Approved as Noted
 Approved with ND Exception Taken
 Revise and Resubmit
 SIGNATURE: _____
 TITLE: _____
 Date: _____

*** NOTE ***
ALL WALLS AND STRUCTURES THAT COME WITHIN 18" OF HOOD MUST BE METAL STUDS AND SHEETROCK. WOOD STUDS OR ANY OTHER COMBUSTIBLE MATERIAL WITHIN 18" OF HOOD NOT ALLOWED.

*** NOTE ***
HOOD MANUFACTURER RECOMMENDS NO RETURNS OR 4-WAY DIFFUSERS WITHIN 10 FEET OF HOOD IN ALL DIRECTION.

*** NOTE ***
MAKEUP AIR SHALL BE DELIVERED INTO SPACE IN MANNER THAT WILL NOT DISRUPT HOODS ABILITY TO CAPTURE AND CONTAIN.

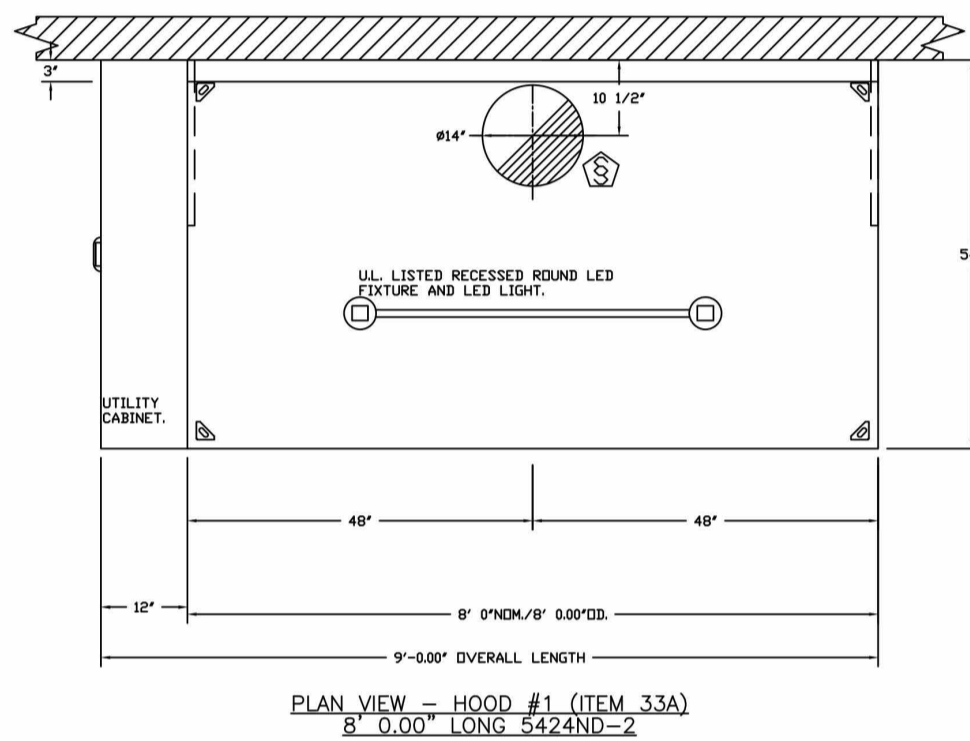

PLAN VIEW - HOOD #1 (ITEM 33A)
9' 0"00" OVERALL LENGTH
9' 0"00" LONG 5424ND-2

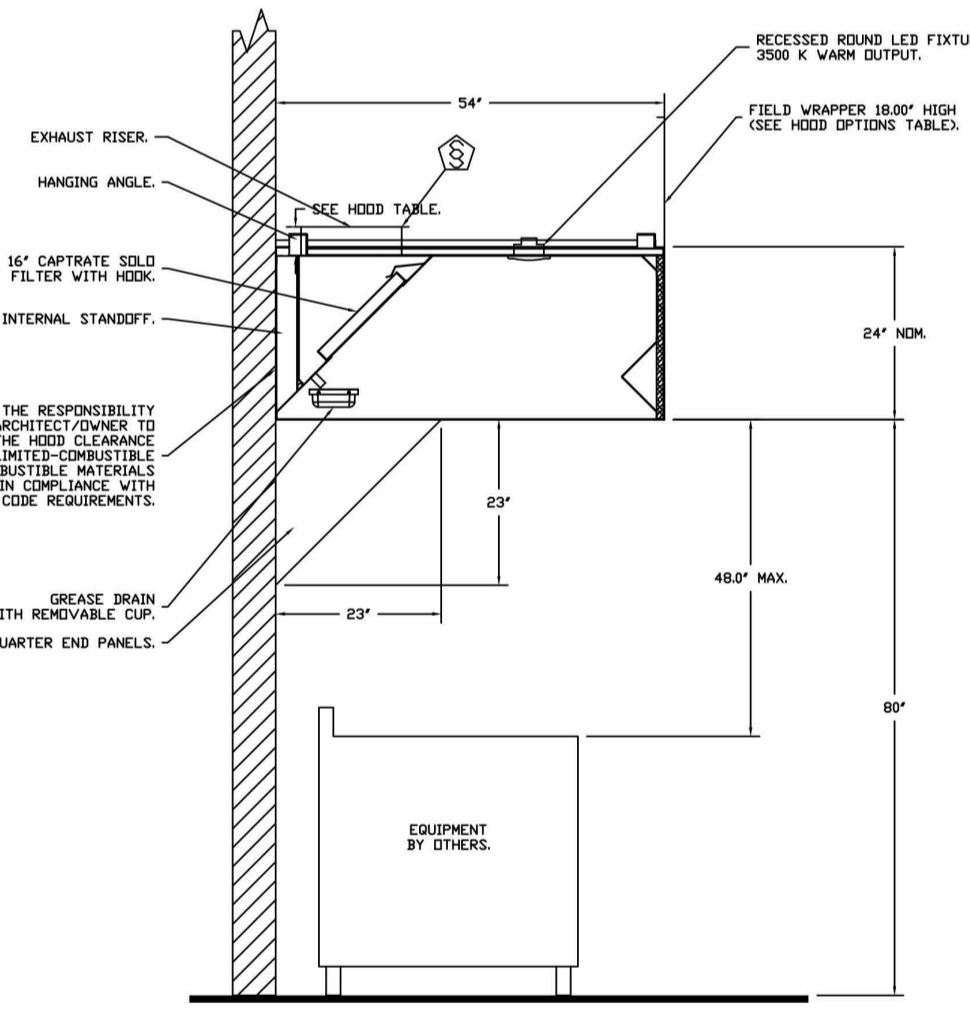

SECTION VIEW - MODEL 5424ND-2
HOOD - #1 (ITEM 33A)

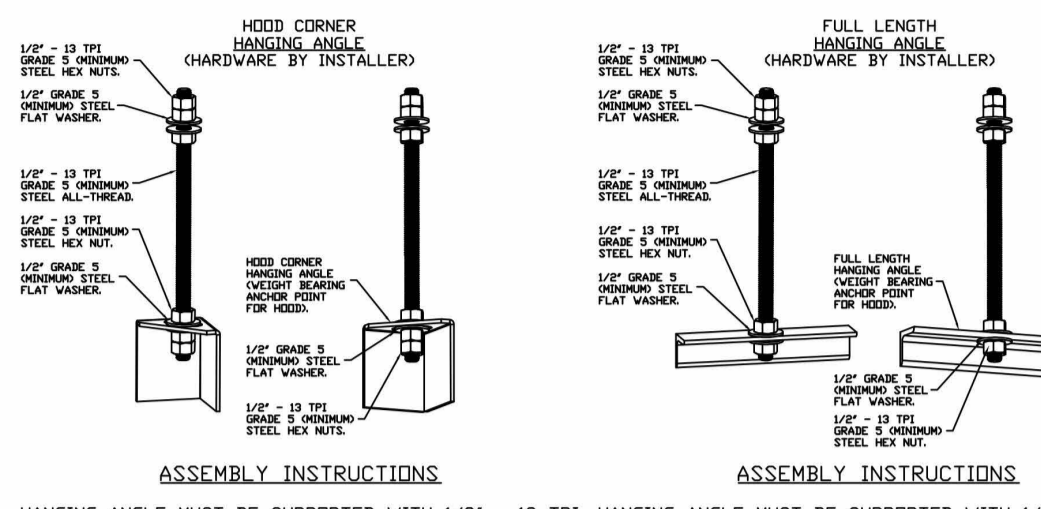

ASSEMBLY INSTRUCTIONS

HANGING ANGLE MUST BE SUPPORTED WITH 1/2" - 13 TPI GRADE 5 OXIDIZING ALL-THREAD SANDWICH HANGING ANGLES AND CEILING ANCHOR POINTS WITH 1/2" GRADE 5 OXIDIZING STEEL FLAT WASHERS AND 1/2" - 13 TPI GRADE 5 OXIDIZING HEX NUTS AS SHOWN. MUST USE DOUBLED HEX NUT CONFIGURATION BENEATH HOOD HANGING ANGLES AND ABOVE CEILING ANCHORS. MAINTAIN 1/4" OF EXPOSED THREADS BENEATH BOTTOM HEX NUT. TORQUE ALL HEX NUTS TO 57 FT-LBS.

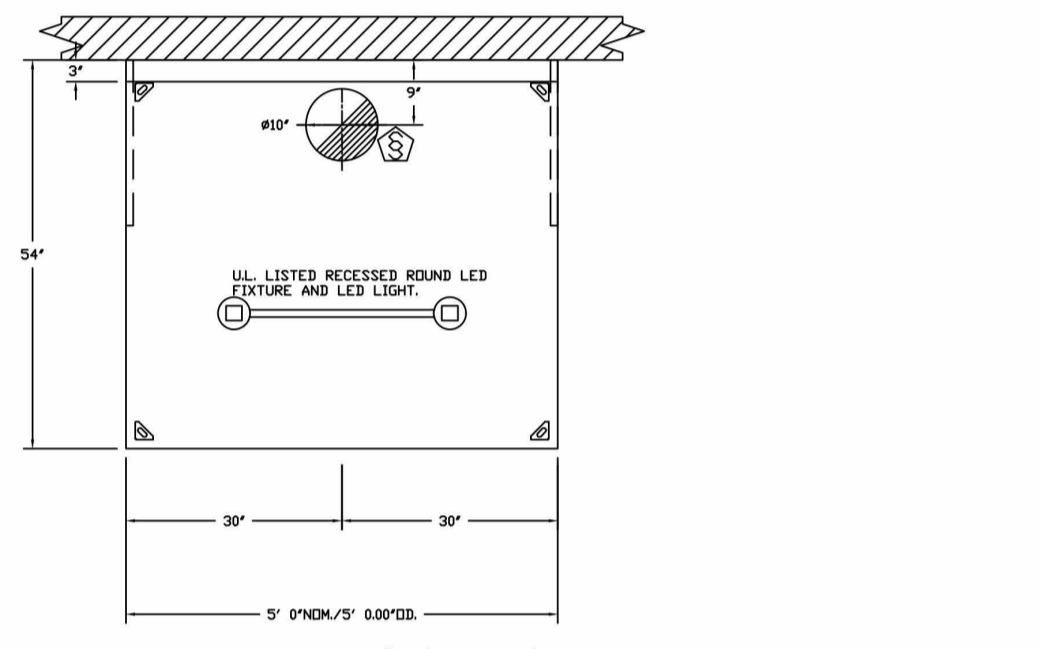

PLAN VIEW - HOOD #2 (ITEM 33B)
5' 0"00" LONG 5424ND-2

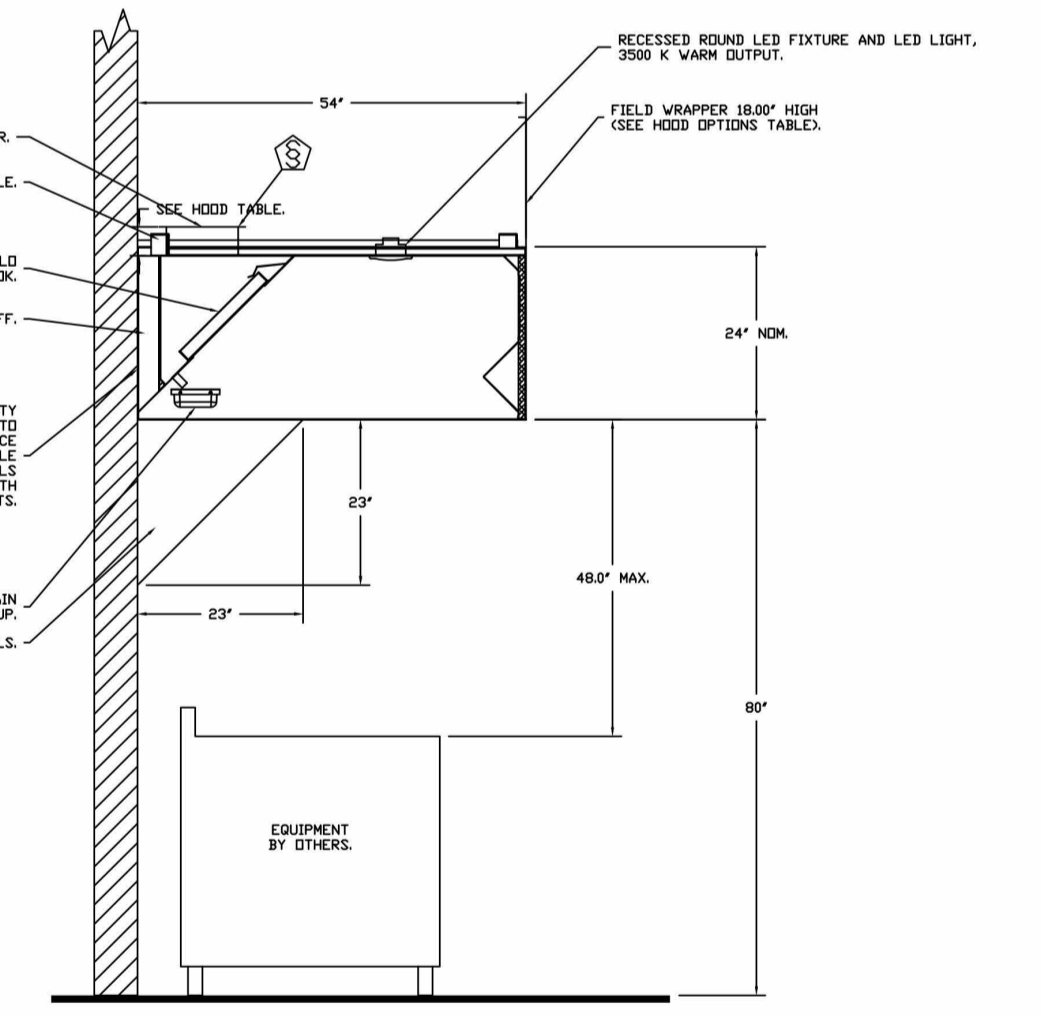

SECTION VIEW - MODEL 5424ND-2
HOOD - #2 (ITEM 33B)

REVISIONS

NO.	DESCRIPTION	DATE

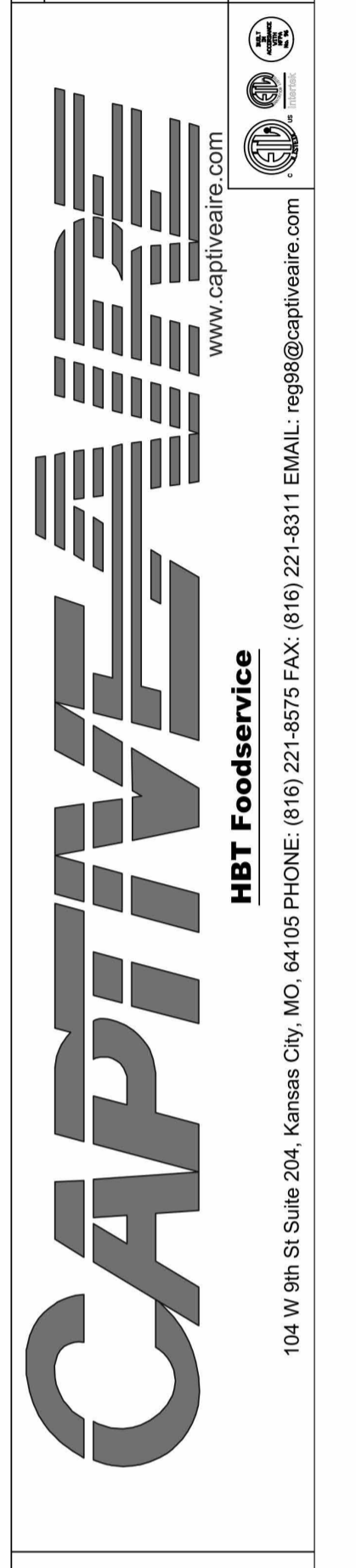

Freddy's - Alexandria, LA
ALEXANDRIA, LA, 71301

DATE: 4/27/2023
DWG #: 5976146
DRAWN BY: michael.co
SCALE: 1/2" = 1'-0"
MASTER DRAWING

SHEET NO.

This drawing has been prepared by the Engineer, or under his supervision. This drawing is provided as an instrument of service by the Design Engineer and is intended for use on the project only. Pursuant to the Architectural Works Copyright Protection Act of 1990, all drawings, specifications, ideas and designs, including those created from, and incorporated in, and those of the Design Engineer, shall remain the property of the Design Engineer. Any reproduction, use, or disclosure of information contained herein without prior written consent of the Engineer is strictly prohibited. © 2023 BC Engineers, Inc.



5720 Reeder Shawnee, KS 66203 (913)262-1772

a new restaurant for:
Lot 6A MacArthur Dr
Alexandria, LA 71301

date 07/28/2023
drawn by Author
checked by Checker
revisions

sheet number
M-300

drawing type
PROTOTYPE DOCUMENTS
project number
23472



REVISIONS	
DESCRIPTION	DATE

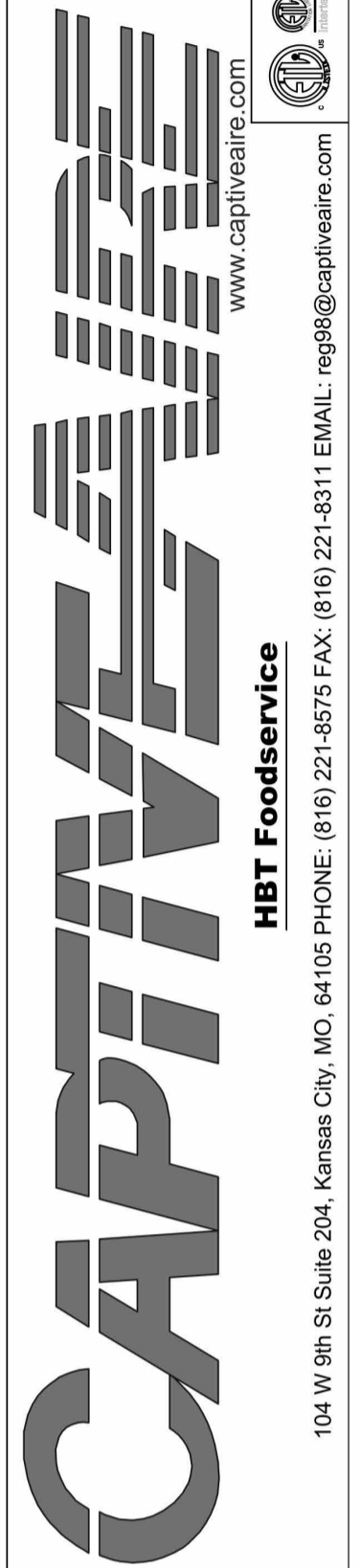

Freddy's - Alexandria, LA
ALEXANDRIA, LA, 71301

DATE: 4/27/2023

DWG.#: 5976146

DRAWN BY: michael.co

SCALE: 1/2" = 1'-0"

MASTER DRAWING

SHEET NO. 3

FAN #3 CASRTU3-1,200-15-20T - HEATER (DDAS-1)

NOTES:

- DO NOT OBSTRUCT OUTSIDE AIR INLET, OUTSIDE AIR COIL OR OUTSIDE AIR FAN.
- DENOTES CORNER WEIGHT.
- ROOF OPENING MUST BE 2' SMALLER THAN CURB DIMENSIONS IN BOTH DIRECTIONS.

*NOTE: SUPPLY DUCT MUST BE INSTALLED TO MEET SMACNA STANDARDS. A MINIMUM STRAIGHT DUCT LENGTH MUST BE MAINTAINED DOWNSTREAM OF UNIT DISCHARGE AS OUTLINED IN AMCA PUBLICATION 201. WHEN USING RECTANGULAR DUCTWORK, ELBOWS MUST BE RADIUS THROAT, RADIUS BACK WITH TURNING VANES. FLEXIBLE DUCTWORK AND SQUARE THROAT/SQUARE BACK ELBOWS SHOULD NOT BE USED. ANY TRANSITION AND/OR TURNS IN THE DUCTWORK WILL CAUSE SYSTEM EFFECT. SYSTEM EFFECT WILL DRASTICALLY INCREASE STATIC PRESSURE AND REDUCE AIRFLOW. DO NOT RELY ON UNIT TO SUPPORT DUCT IN ANY WAY. FAILURE TO PROPERLY SIZE DUCTWORK MAY CAUSE SYSTEM EFFECTS AND REDUCE PERFORMANCE OF THE EQUIPMENT. SUGGESTED STRAIGHT DUCT SIZE IS 21.5" x 39".

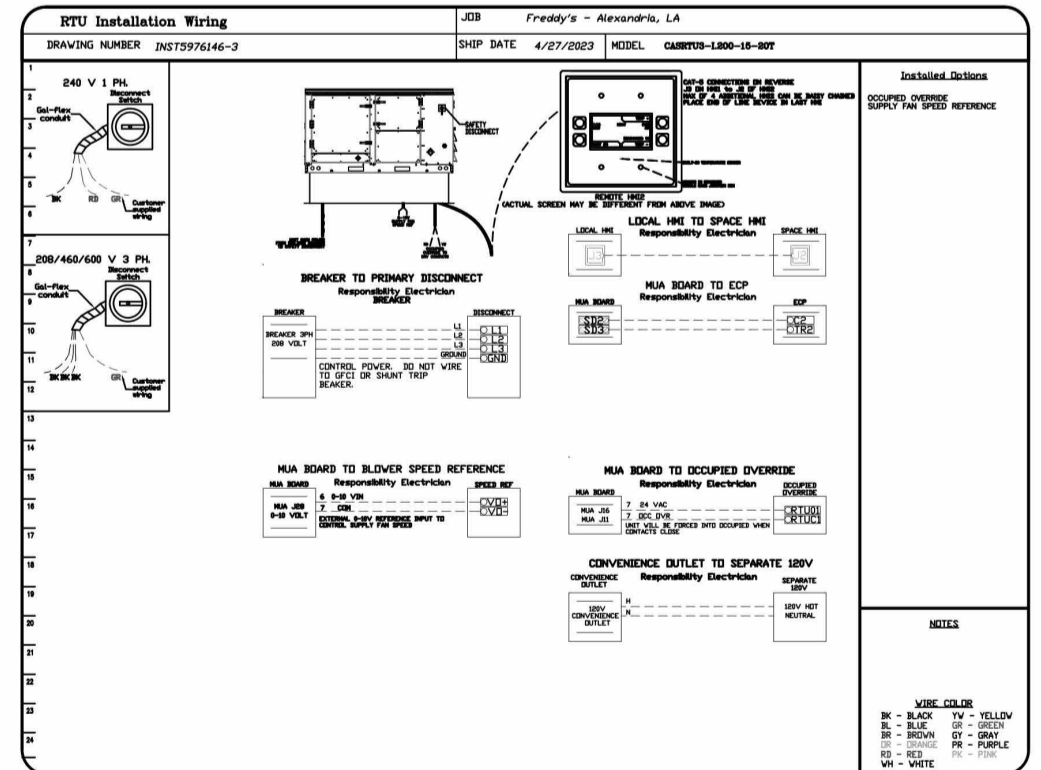
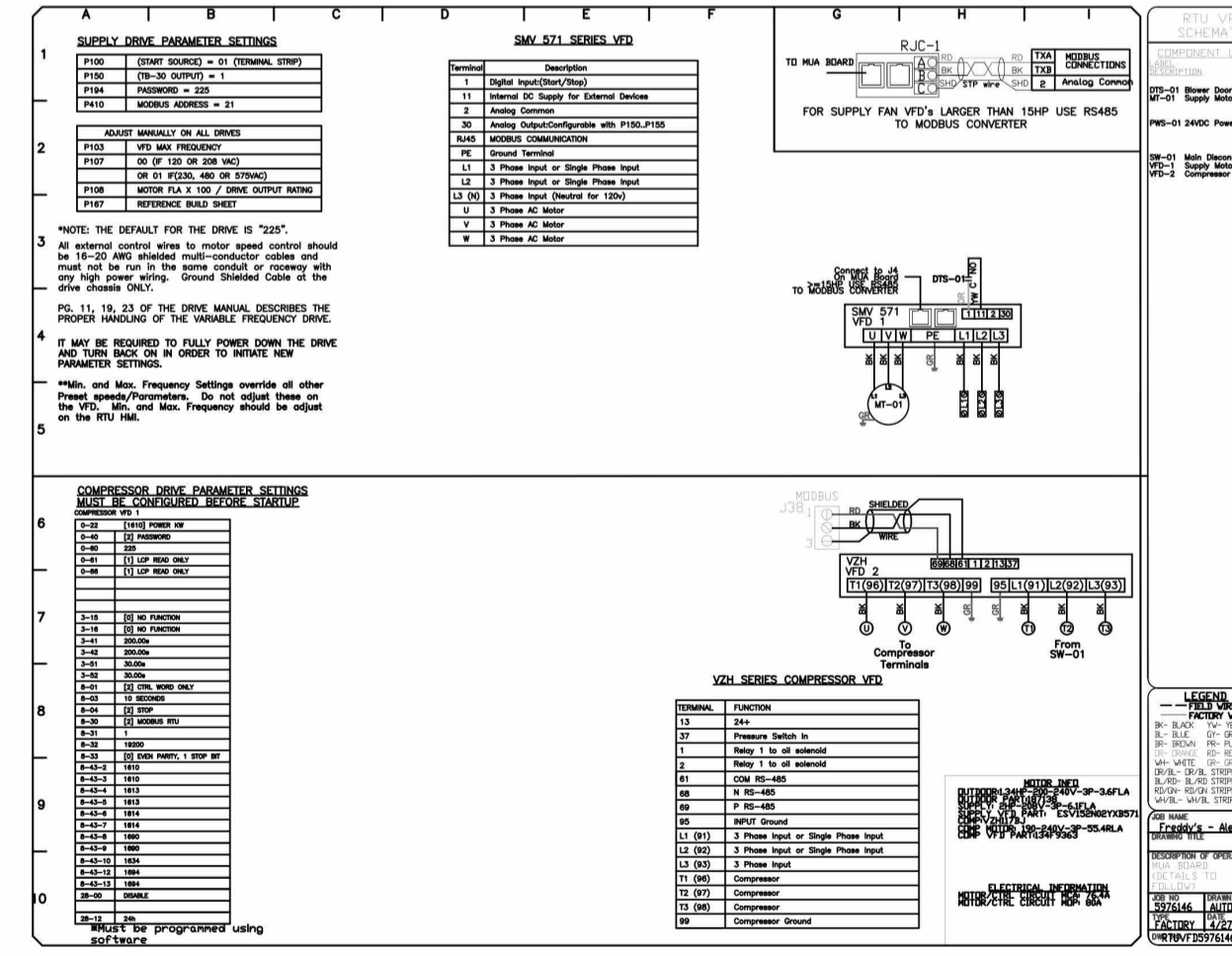
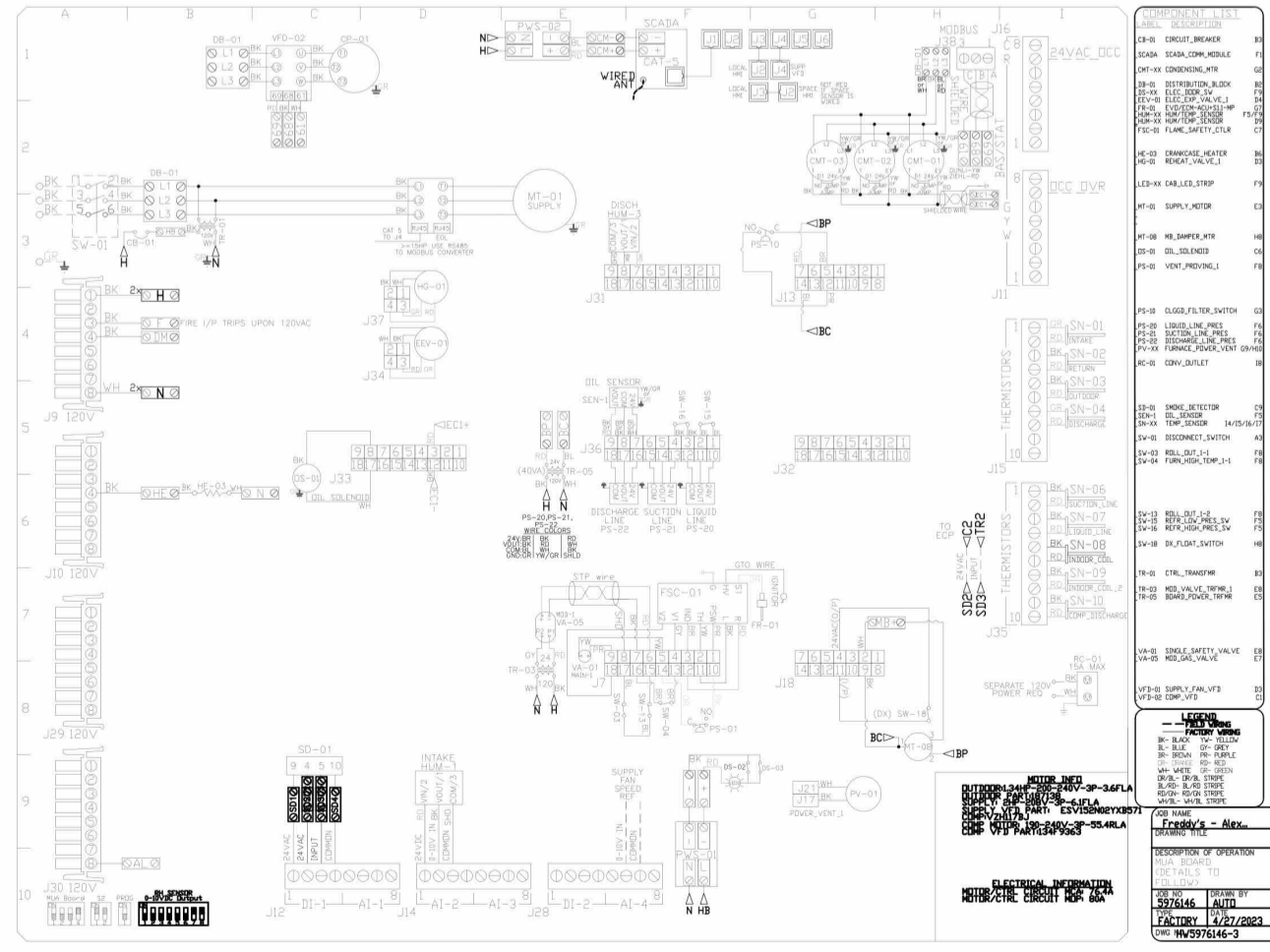
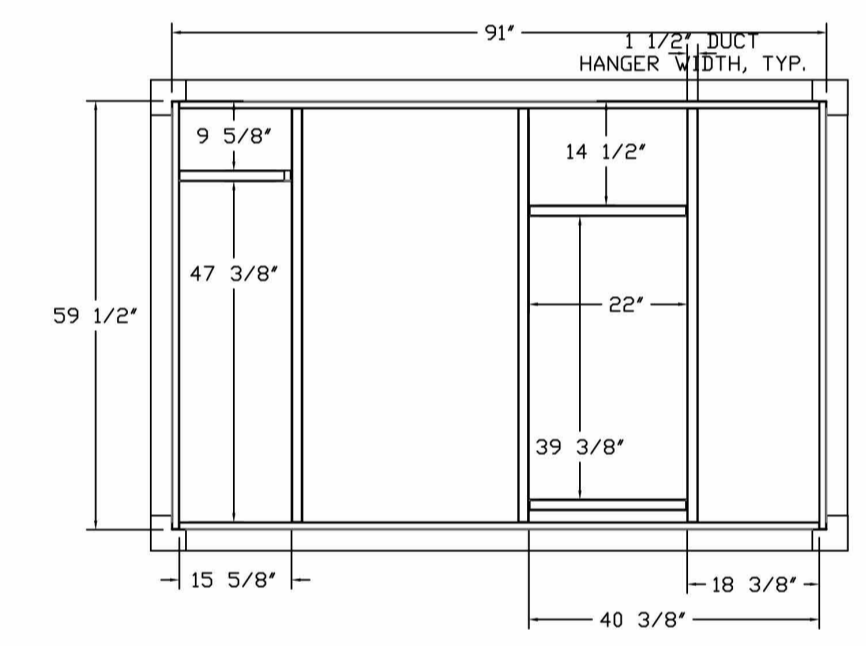
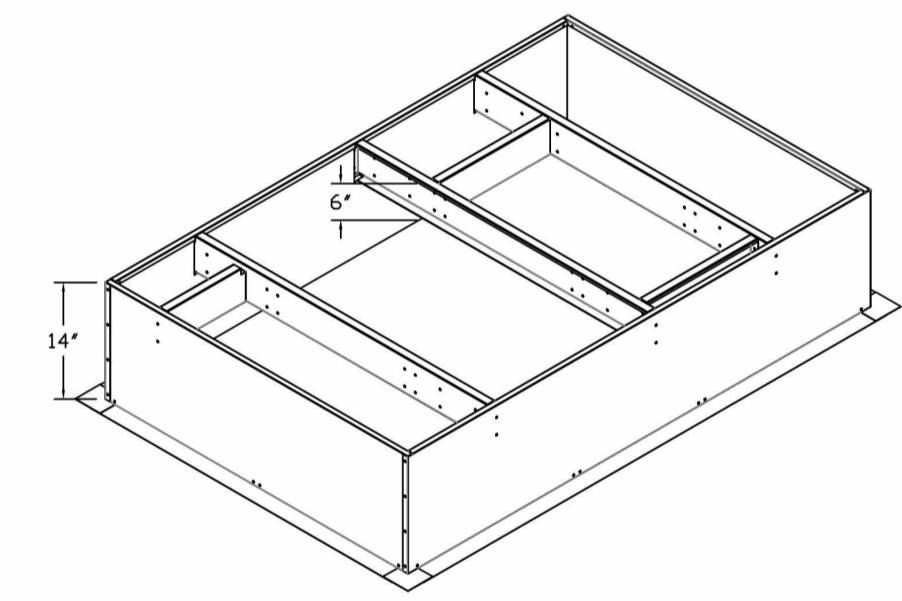
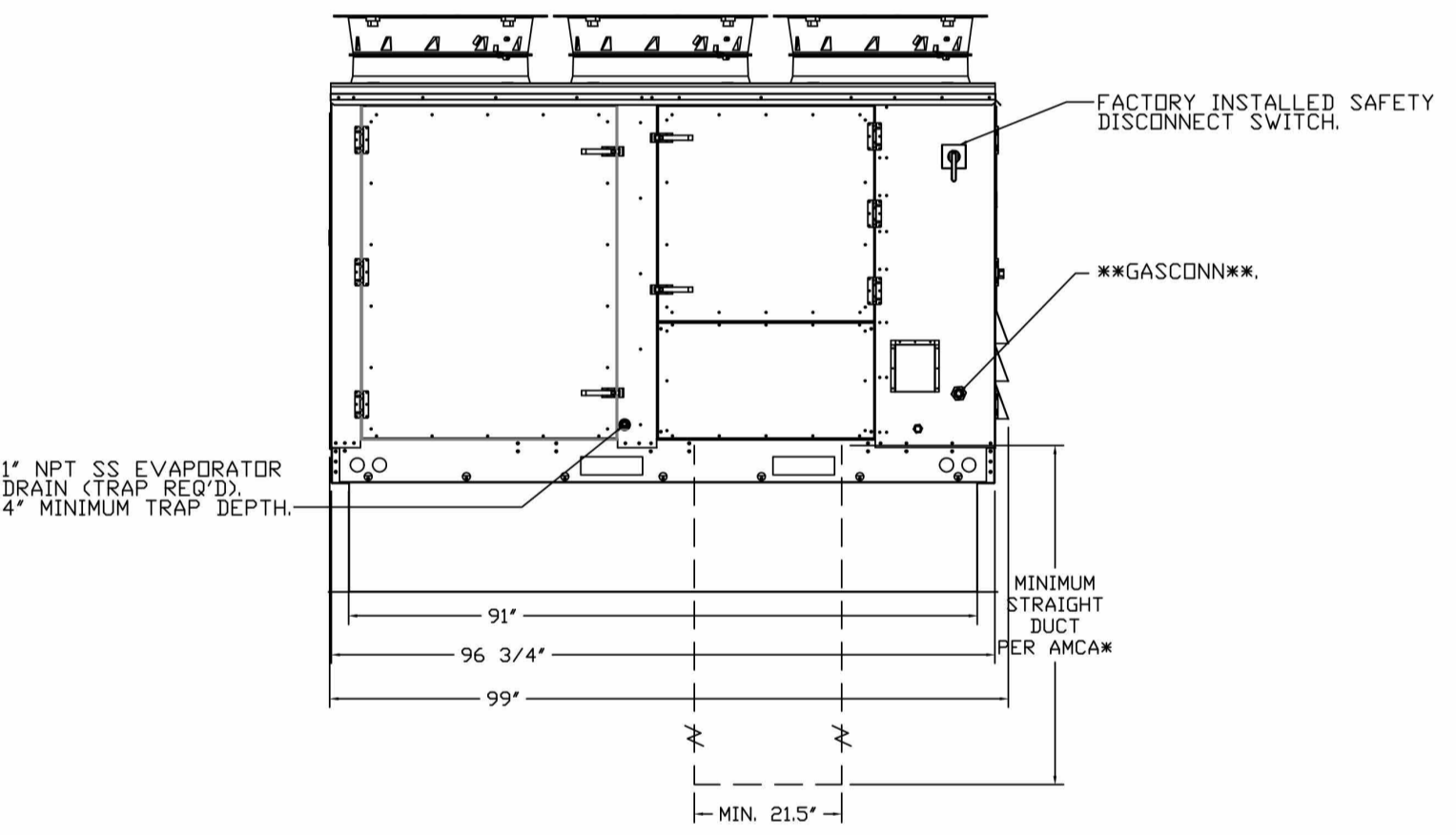
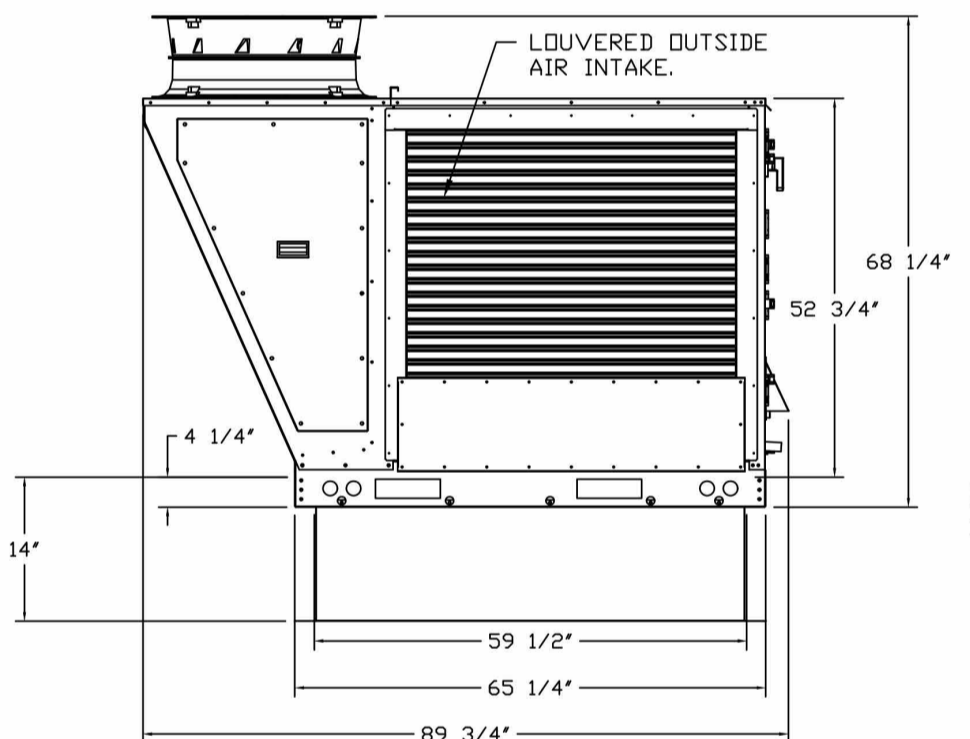
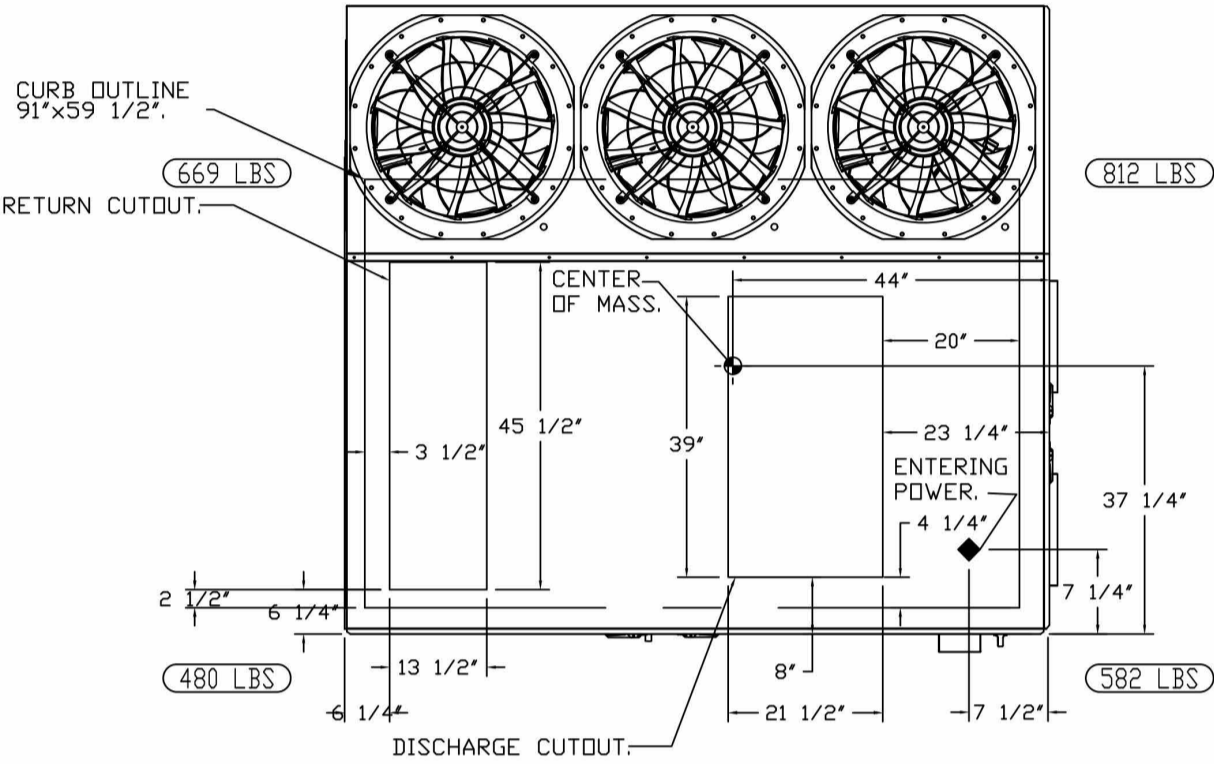
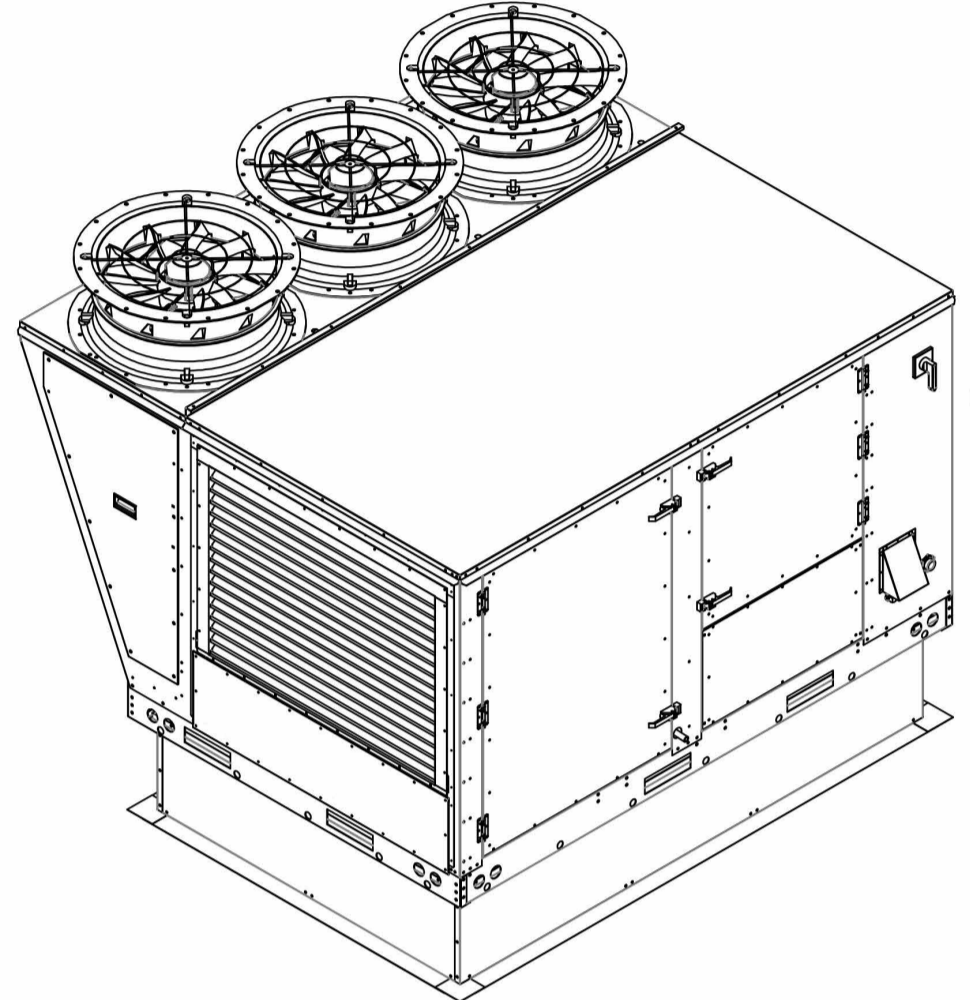

This drawing has been prepared by the Engineer, or under his supervision. This drawing is provided as an instrument of service by the Designer/Engineer and is intended for use on the project only. Pursuant to the Architectural Works Copyright Protection Act of 1990, all drawings, specifications, ideas and designs, including the overall form, arrangement and composition of graphic and electronic appearing herein, constitute the original, copyrighted work of the Designer/Engineer. Any reproduction, use, or disclosure of information contained herein without prior written consent of the Engineer is strictly prohibited. © 2023 BC Engineers, Inc.

a new restaurant for:
Lot 6A MacArthur Dr
Alexandria, LA 71301

date
07/28/2023
drawn by
Author
checked by
Checker
revisions

sheet number
M-302

drawing type
PROTOTYPE DOCUMENTS
project number
23472



104 W 9th St, Suite 204, Kansas City, MO 64105 PHONE: (816) 221-8311 EMAIL: reg@caplive.com

CAPTIVE

Freddy's - Alexandria, LA
ALEXANDRIA, LA, 71301

a new restaurant for:
Lot 6A MacArthur Dr
Alexandria, LA 71301

NO	TAG	PACKAGE #	LOCATION	QUANTITY	OPTION	FAN TAG	TYPE	HP	VOL	FLA	
1	ECM-1	BCV-001	UTILITY CABINET LEFT HOOD # 1	1 FAN	SMART CONTROLS DCV	ITEM 741	EXHAUST	2	1.000	0.08	3.0

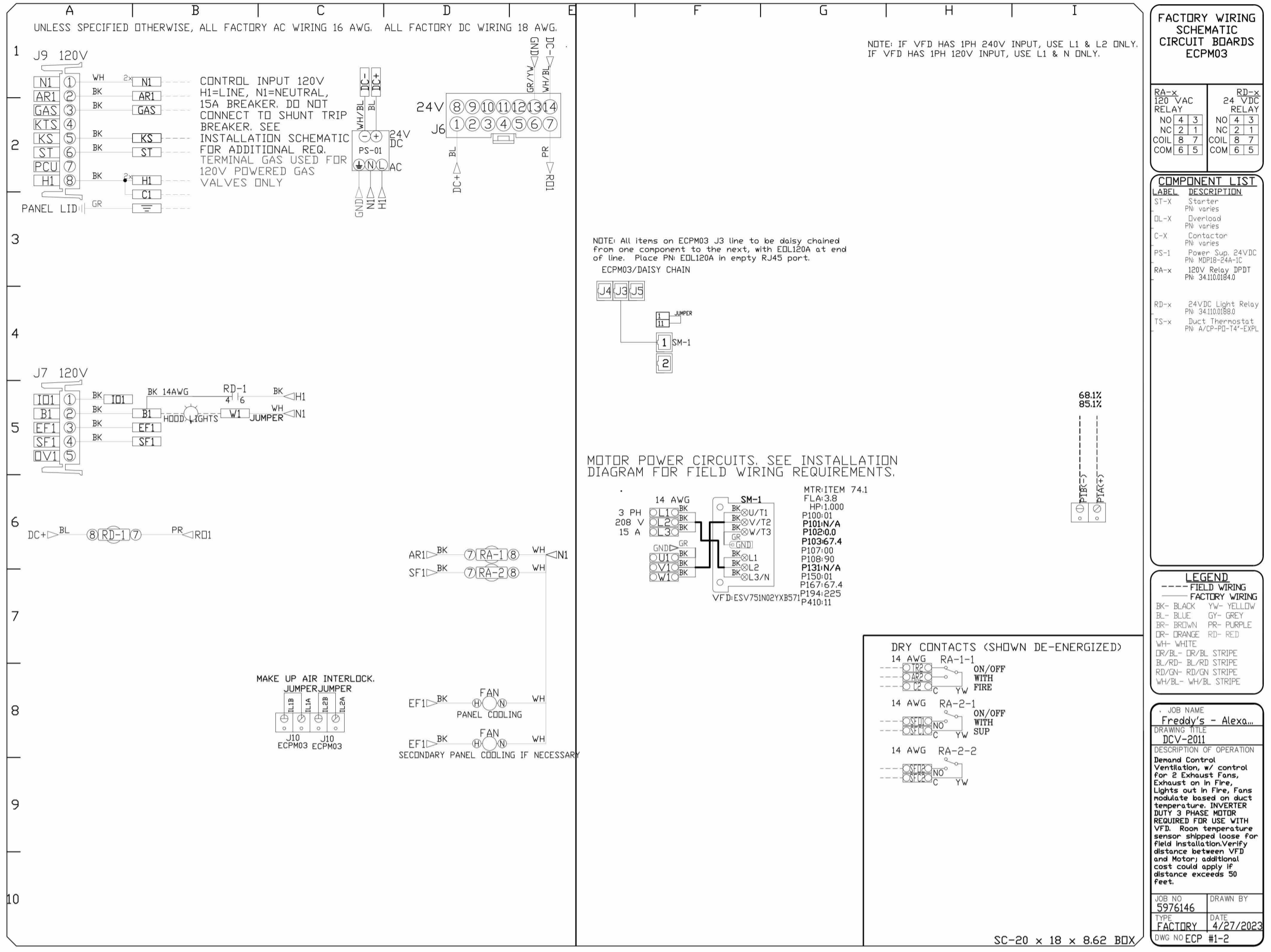
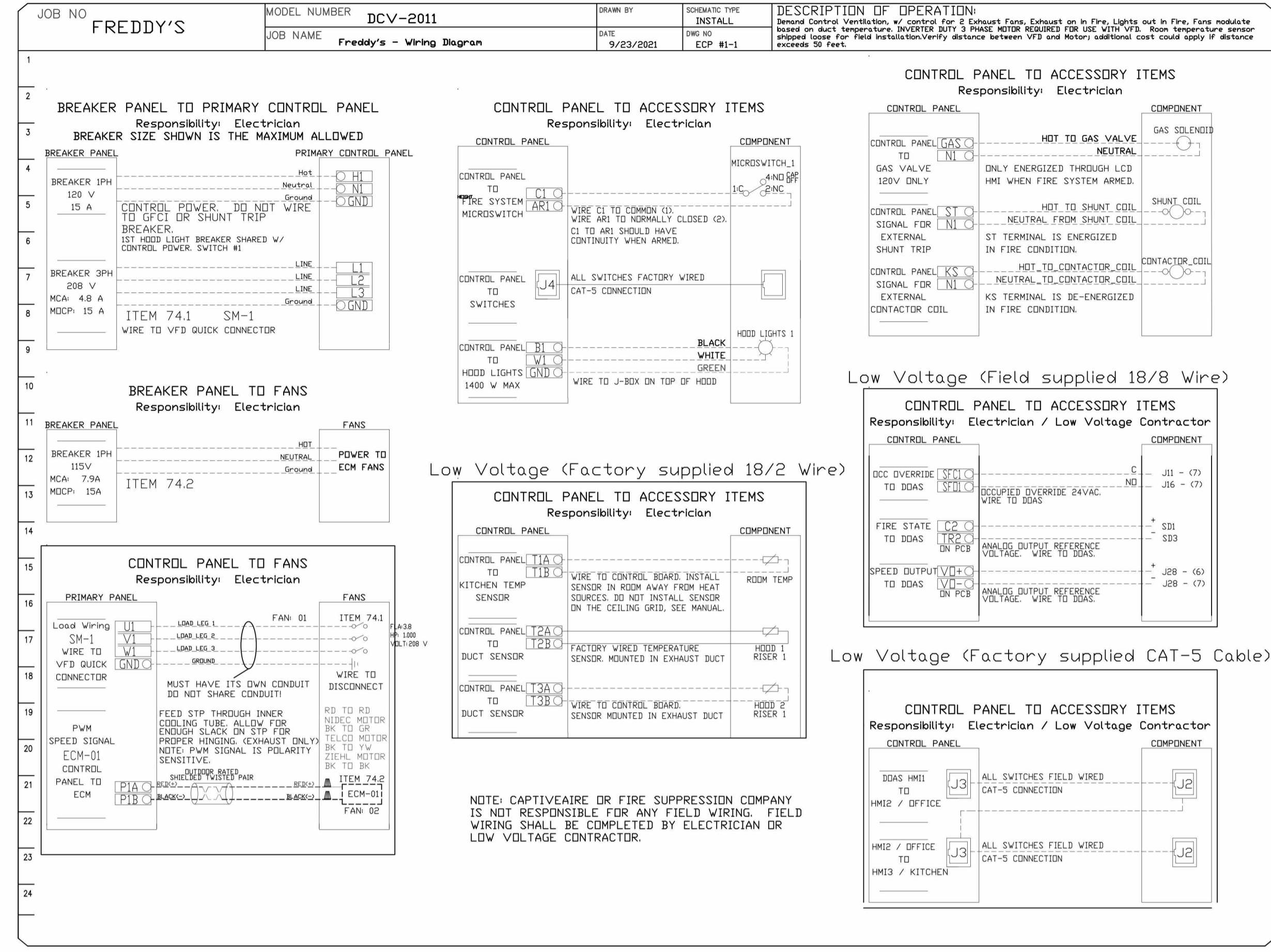

DEMAND CONTROL VENTILATION HOOD CONTROL PANEL SPECIFICATIONS:

- CONTROL PANEL SHALL BE LISTED BY ETL (UL 508A) AND SHALL COMPLY WITH DEMAND VENTILATION SYSTEM TURNDOWN REQUIREMENTS OUTLINED IN IECC 403.2.8 (2015).
- CONTROL ENCLOSURE SHALL BE NEMA 1 RATED AND LISTED FOR INSTALLATION INSIDE OF THE EXHAUST HOOD UTILITY CABINET. THE CONTROL ENCLOSURE MAY BE CONSTRUCTED OF STAINLESS STEEL OR PAINTED STEEL.
- TEMPERATURE PROBES LOCATED IN THE EXHAUST DUCT RISERS SHALL BE CONSTRUCTED OF STAINLESS STEEL.
- A DIGITAL CONTROLLER SHALL BE PROVIDED TO ACTIVATE THE HOOD EXHAUST FANS DYNAMICALLY BASED ON A FIXED DIFFERENTIAL BETWEEN THE AMBIENT AND DUCT TEMPERATURE SENSORS. THIS FUNCTION SHALL MEET THE REQUIREMENTS OF IMC 507.1.1.
- A DIGITAL CONTROLLER SHALL PROVIDE ADJUSTABLE HYSTERESIS SETTINGS TO PREVENT CYCLING OF THE FANS AFTER THE COOKING APPLIANCES HAVE BEEN TURNED OFF AND/OR THE HEAT IN THE EXHAUST SYSTEM IS REDUCED.
- A DIGITAL CONTROLLER SHALL PROVIDE AN ADJUSTABLE MINIMUM FAN RUN-TIME SETTING TO PREVENT FAN CYCLING.
- INTERNAL FREQUENCY DRIVES (VFDs) SHALL BE PROVIDED FOR FANS AS REQUIRED. THE DIGITAL CONTROLLER SHALL MODULATE THE VFDs BETWEEN A MINIMUM SETPOINT AND A MAXIMUM SETPOINT ON DEMAND. THE DUCT TEMPERATURE SENSOR INPUTS TO THE DIGITAL CONTROLLER SHALL BE USED TO CALCULATE THE SPEED REFERENCE SIGNAL.
- AN INTERNAL ALGORITHM TO THE DIGITAL CONTROLLER SHALL MODULATE SUPPLY FAN VFD SPEED PROPORTIONAL TO ALL EXHAUST FANS THAT ARE LOCATED IN THE SAME FAN GROUP AS THE SUPPLY FAN.
- THE SYSTEM SHALL OPERATE IN PREP MODE DURING LIGHT COOKING LOAD OR COOL DOWN MODE WHEN SUFFICIENT HEAT REMAINS UNDERNEATH THE HOOD SYSTEM AFTER COOKING OPERATIONS HAVE COMPLETED. OPERATION DURING EITHER OF THESE PERIODS WILL DISABLE THE SUPPLY FANS AND PROVIDE AN EXHAUST FAN SPEED THAT IS EQUAL TO THE MINIMUM VENTILATION REQUIREMENT.
- A DIGITAL CONTROLLER SHALL DISABLE THE SUPPLY FANS, ACTIVATE THE EXHAUST FANS, ACTIVATE THE APPLIANCE SHUNT TRIP, AND DISABLE AN ELECTRIC GAS VALVE AUTOMATICALLY WHEN FIRE CONDITION IS DETECTED ON A COVERED HOOD.
- A DIGITAL CONTROLLER SHALL ALLOW FOR EXTERNAL BMS FAN CONTROL VIA DRY CONTACT (EXTERNAL CONTROL SHALL NOT OVERRIDE FAN OPERATION LOGIC AS REQUIRED BY CODE).
- AN LCD INTERFACE SHALL BE PROVIDED WITH THE FOLLOWING FEATURES:
 - ON/OFF PUSH BUTTON FAN & LIGHT SWITCH ACTIVATION.
 - INTEGRATED GAS VALVE RESET FOR ELECTRONIC GAS VALVES AND RESET RELAY REQUIRED.
 - VFD FAULT DISPLAY WITH AUDIBLE & VISUAL ALARM NOTIFICATION.
 - DUCT TEMPERATURE SENSOR FAILURE DETECTION WITH AUDIBLE & VISUAL ALARM NOTIFICATION.
 - MIS-WIRED DUCT TEMPERATURE SENSOR DETECTION WITH AUDIBLE & VISUAL ALARM NOTIFICATION.
 - A SINGLE LOW VOLTAGE CAT-5 RJ45 WIRING CONNECTION.
 - AN ENERGY SAVINGS INDICATOR THAT UTILIZES MEASURED kWh FROM THE VFDs.

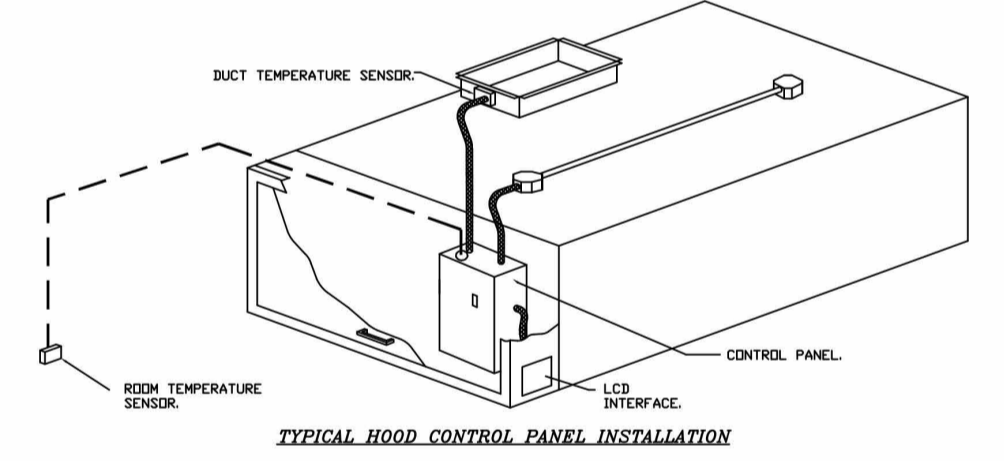

SEQUENCE OF OPERATIONS:

- THE HOOD CONTROL PANEL IS CAPABLE OF OPERATING IN ONE OR MORE OF THE FOLLOWING STATES AT ANY GIVEN TIME:
 - AUTO/IDLE:** THE SYSTEM OPERATES BASED ON THE DIFFERENTIAL BETWEEN ROOM TEMPERATURE AND THE TEMPERATURE AT THE HOOD CAVITY OR EXHAUST DUCT COLLAR. FANS ACTIVATE AT A CONFIGURABLE TEMPERATURE DIFFERENTIAL THRESHOLD. DEPENDING ON THE JOB CONFIGURATION EACH FAN ZONE CAN BE CONFIGURED AS STATIC OR DYNAMIC. THESE TERMS REFER TO WHETHER A VARIABLE MOTOR (SUCH AS EC MOTORS OR VFD DRIVEN MOTORS) MODULATE WITH TEMPERATURE. IF THE PANEL IS EQUIPPED WITH VARIABLE SPEED FANS AND THE ZONE IS DEFINED AS "DYNAMIC", THESE WILL MODULATE WITHIN A USER-DEFINED RANGE BASED ON THE TEMPERATURE DIFFERENTIAL. PANELS EQUIPPED WITH VARIABLE SPEED FANS AND A FAN ZONE DEFINED AS "STATIC" FANS WILL RUN AT A SET SPEED CALCULATED FOR THE DRIVE. DEMAND CONTROL VENTILATION SYSTEMS ARE CAPABLE OF MODULATING EXHAUST AND MAKE UP AIR FAN SPEEDS PER THE REQUIREMENTS OUTLINED IN IECC 403.2.8.
 - MANUAL:** THE SYSTEM OPERATES BASED ON HUMAN INPUT FROM AN HMI.
 - SCHEDULE:** A WEEKLY SCHEDULE CAN BE SET TO RUN FANS FOR A SPECIFIED PERIOD THROUGHOUT THE DAY. THERE ARE THREE OCCUPIED TIMES PER DAY TO ALLOW FOR THE USER TO SET UP A TIME THAT IS SUITABLE TO THEIR NEEDS. ANY TIME THAT IS WITHIN THE DEFINED OCCUPIED TIME, THE SYSTEM WILL RUN AT MODULATE HOOD AND FOLLOW THE FAN PROCEDURE ALGORITHM BASED ON TEMPERATURE DURING THIS TIME. DURING UNOCCUPIED TIME, THE SYSTEM WILL HAVE AN EXTRA OFFSET TO PREVENT UNEXPECTED ACTIVATION OF THE SYSTEM DURING A TIME WHERE THE SYSTEM IS NOT BEING OCCUPIED.
 - OTHER:** THE SYSTEM OPERATES BASED ON THE INPUT FROM AN EXTERNAL SOURCE (DDC, BMS OR HARD-WIRED INTERLOCK).
 - FIRE:** UPON ACTIVATION OF THE HOOD FIRE SUPPRESSION SYSTEM, THE EXHAUST FAN WILL COME ON OR CONTINUE TO RUN. THE HOOD MAKEUP AIR WILL SHUTDOWN, AND A SIGNAL WILL SHUT OFF VIA A MECHANICAL/ELECTRICAL GAS VALVE ACTIVATED BY THE HOOD FIRE SUPPRESSION SYSTEM.

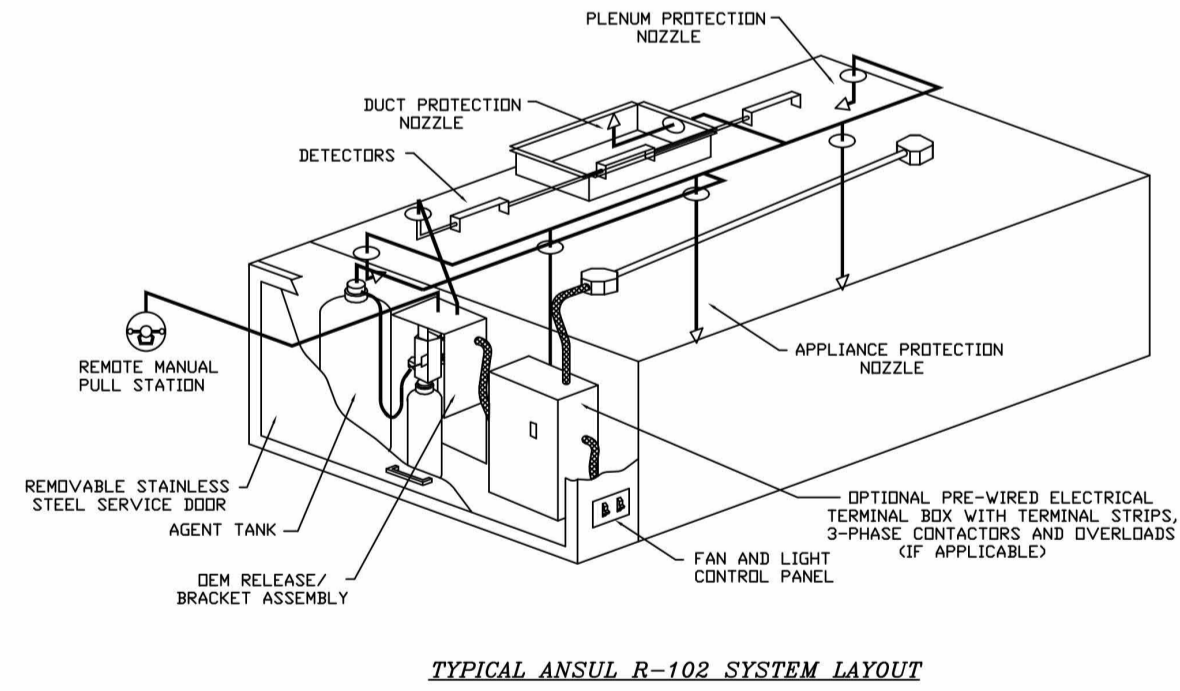

SPECIFICATIONS

THE RESTAURANT FIRE SUPPRESSION SYSTEM SHALL BE THE PRE-ENGINEERED TYPE WITH A FIXED NOZZLE AGENT DISTRIBUTION NETWORK. IT SHALL BE LISTED WITH UNDERWRITERS LABORATORIES, INC. (UL).

THE SYSTEM SHALL BE CAPABLE OF AUTOMATIC DETECTION AND ACTUATION WITH LOCAL OR REMOTE MANUAL ACTUATION. ACCESSORIES SHALL BE AVAILABLE FOR MECHANICAL OR ELECTRICAL GAS LINE SHUT-OFF APPLICATIONS.

THE EXTINGUISHING AGENT SHALL BE A PROFESSIONAL GRADE, PROFESSIONAL ACETATE-BASED FORMULATION DESIGNED FOR FLAME KNOCKDOWN AND SECUREMENT OF GREASE-RELATED FIRES. IT SHALL BE AVAILABLE IN PLASTIC CONTAINERS WITH INSTRUCTIONS FOR LIQUID AGENT HANDLING AND USAGE.

THE REGULATED RELEASE MECHANISM SHALL BE COMPATIBLE WITH A FUSIBLE LINK DETECTION SYSTEM. THE FUSIBLE LINK SHALL BE SELECTED AND INSTALLED ACCORDING TO THE OPERATING TEMPERATURE IN THE VENTILATING SYSTEM. THE FUSIBLE LINK SHALL BE SUPPORTED BY A DETECTOR BRACKET/LINKAGE ASSEMBLY.

Contact COA Electrical
Inspector, Jeff Lachney at
318-473-1341
for NEC code clarifications.

DATE:	4/27/2023
DWG.#:	5976146
DRAWN BY:	michaelco
SCALE:	1/2" = 1'-0"
MASTER DRAWING	
SHEET NO.	4

This drawing has been prepared by the Engineer, or under his supervision. This drawing is provided as an instrument of service by the Designer/Engineer and is intended for use on the project only. Pursuant to the Architectural Works Copyright Protection Act of 1990, all drawings, specifications, data and designs including the notes hereon, are the property of Davidson Architecture & Engineering, Inc. and shall remain the property of Davidson Architecture & Engineering, Inc. No reproduction or distribution of any part of this drawing without prior written consent of the Engineer is strictly prohibited. © 2023 BC Engineers, Inc.

BC ENGINEERS INCORPORATED
5720 Reeder Shawnee, KS 66203 (913)262-1772

sheet number
M-303
drawing type
PROTOTYPE DOCUMENTS
project number
23472