

U.S. Army Corps of Engineers (USACE) TRANSMITTAL OF SHOP DRAWINGS, EQUIPMENT DATA, MATERIAL SAMPLES, OR MANUFACTURER'S CERTIFICATES OF COMPLIANCE For use of this form, see ER 415-1-0; the proponent agency is CECW-CE	DATE 9/19/2022	TRANSMITTAL NO. 23 64 10-1
---	-------------------	-------------------------------

SECTION I - REQUEST FOR APPROVAL OF THE FOLLOWING ITEMS (This section will be initiated by the contractor)

TO: 81st RSC Geographic District ROs 69A Hagood Avenue Charleston, SC 29403-5107	FROM: TEAM CONSTRUCTION 846 BELL FORK RD JACKSONVILLE NC 28540-6312 USA	CONTRACT NO. W912HP21D6006 W912HP22F1176	CHECK ONE: <input checked="" type="checkbox"/> THIS IS A NEW TRANSMITTAL <input type="checkbox"/> THIS IS A RESUBMITTAL OF TRANSMITTAL _____
---	--	---	--

SPECIFICATION SEC. NO. (Covers only one section with each transmittal) 23 64 10-	PROJECT TITLE AND LOCATION 01 FY22 81st NC026 HEP Reset; W'ville, NC, Winterville, NC	THIS TRANSMITTAL IS FOR: (Check one) <input type="checkbox"/> FIO <input checked="" type="checkbox"/> GA <input type="checkbox"/> DA <input type="checkbox"/> CR <input type="checkbox"/> DA/CR <input type="checkbox"/> DA/GA
---	--	---

ITEM NO. <small>(See Note 3)</small>	DESCRIPTION OF SUBMITTAL ITEM <small>(Type size, model number/etc)</small>	SUBMITTAL TYPE CODE <small>(See Note 8)</small>	NO. OF COPIES	CONTRACT DOCUMENT REFERENCE		CONTRACTOR REVIEW CODE	VARIATION <small>Enter "Y" if requesting a variation (See Note 6)</small>	USACE ACTION CODE <small>(Note 9)</small>
				SPEC. PARA. NO.	DRAWING SHEET NO.			
a.	b.	c.	d.	e.	f.	g.	h.	i.
1	Water Chiller	03 - PRODUCT	1	2.5		A	No	
11	Refrigeration System	07 -	1	3.1.9		A	No	
13	Water Chiller - Installation Instruction	08 -	1	3.1		A	No	

REMARKS	I certify that the above submitted items had been reviewed in detail and are correct and in strict conformance with the contract drawings and specifications except as otherwise stated.	
	NAME OF CONTRACTOR	SIGNATURE OF CONTRACTOR

SECTION II - APPROVAL ACTION

ENCLOSURES RETURNED (List by Item No.)	NAME AND TITLE OF APPROVING AUTHORITY	SIGNATURE OF APPROVING AUTHORITY	DATE
--	---------------------------------------	----------------------------------	------



SUBMITTAL DATA SHEET

To:

Project:

Architect:

Engineer:

Product:

Supplier:

Spec Section:

Drawing:

Submittal Notes:

APPROVAL STAMPS

<p>East Bound Mechanical 3195-B Airport Blvd. Wilson, NC 27896</p>  <p>Reviewed - Furnish Pending A/E Approval/Review</p> <p>Notes Indicated</p> <p>Resubmittal - See Comments</p> <p>Reviewed By:</p> <p>Date:</p> <p>Review of this drawing and or data does not indicate approval of variations to the contract documents or coordination with other trades as may be required.</p>	<p>General Contractor</p>	<p>Architect/Engineer</p>
--	----------------------------------	----------------------------------

EQUIPMENT SUBMITTAL FOR APPROVAL

PROJECT: N026 Army Reserve Center (Winterville)
LOCATION: Winterville, NC



AIR-COOLED CHILLER

EQUIPMENT	JCI-York YLAA Air Cooled Chiller
UNIT TAGS	CH-01
QUANTITY	1

SOLD To:
Eastbound Mechnaicl

ENGINEER:
Cromwell

PREPARED BY: JOHNSON
CONTROLS, INC.
919-215-5426

DATE:
9/14/2022

REVISION:
01



TABLE OF CONTENTS

(YLAA)

BOM Data

Design Conditions Datasheet

Unit Drawing

AVM Report

Wiring Details

Receiving / Rigging Instructions

Warranties

Submittal Approval Page



BILL OF MATERIAL DATA

EQUIPMENT	YLAA - Air Cooled Chiller
UNIT TAGS	CH-01
QTY	1

Items Included

- Refrigerant Type: R410a
- Power: 460-3-60.0 Application
- Power Connection: SP Circuit Breaker w/Lockable Handle and 65kA SCWR
- Ultra Quiet Fans
- 3/4 inch Thick Insulation of Evaporator
- All Aluminum Microchannel Coils with Enviroguard Coating
- Service Isolation Valves
- Louvered Enclosure Panels
- BACNet MSTP Communication Card
- Thermal Dispersion Flow Switch
- Controls Transformer
- Low/High Ambient Kit
- Hot Gas Bypass
- Entire Unit Parts, Labor, Refrigerant Warranty: 18 months from date of Shipment or 1 Year from date of Start Up, whichever comes first.
- Compressor Parts & Labor Warranty: 66 months from date of Shipment or 5 Year from date of Start Up, whichever comes first.
- 5 Year Corrosion Warranty provided on Microchannel with Enviroguard Coating.
- Start-up

Items NOT Included

- Rigging Equipment into Place.

Items Included but Installed by Others

- Neoprene Isolators

Unit Tag	Qty	Model No	Net Cooling Capacity (ton.R)	Nominal Voltage	Refrigerant Type
CH-01	1	YLAA0200HE46XFBBCTX	191.4	460-3-60.0	R410A

PIN:

YLAA0200HE	46XFBBCTXA	SXBLXCXX42	SE1XXXHXXX	YAXGTX7XX	XLGNF1XXXX			
...5...10	...5...20	...5...30	...5...40	...5...50	...5...60	...5...70	...5...80	...5...90

Evaporator Data		Evaporator Data (Cont.)		Performance Data	
EWT (°F)	54.00	Fluid Volume (USGAL)	12.68	EER (Btu/W-h)	9.975
LWT (°F)	42.00	Min. Flow Rate (USGPM)	229.8	IPLV.IP (Btu/W-h)	16.92
				NPLV.IP (Btu/W-h)	16.58
Design Flow Rate (USGPM)	380.7	Max. Flow Rate (USGPM)	624.5		
Evap. Press. Drop (ft H2O)	12.8				
Fluid	Water	Condenser Data		Physical Data	
Strainer Press. Drop (ft H2O)	3.68	Ambient Temp. Design (°F)	95.0	Rigging Wt. (lb)	10033
Ext. Kit Press. Drop (ft H2O)	1.02	Altitude (ft)	0.000	Operating Wt. (lb)	10163
Total Press. Drop (ft H2O)	17.5	Compressor Type	Scroll - Hermetic	Refrigerant Charge (lb)	190.9
Fouling Factor (h.ft ² .F/Btu)	0.000100				

Electrical Data				
Circuit	1	2	3	4
Compressor RLA	51 / 51 / 51	51 / 51 / 51		
Fan QTY/FLA (each)	6 / 4	6 / 4		
High LRA Current	316 / 316 / 316	316 / 316 / 316		

Single Point				
Min. Circuit Ampacity	374			
Recommended Fuse/CB Rating	400			
Max. Inverse Time CB Rating	400			
Max. Dual Element Fuse Size (A)	400			
Unit Short Circuit Withstand (STD)	65 [kA]			
Wires Per Phase	2 + 1			
Wire Range (Lug Size)	#3/0 AWG - 250 kcmil + 250 - 500 kcmil			
Starter Type	Across The Line			
			Operating Condition Electrical Data	
			Compressor kW	210.1
			Total Fan kW	20.16
			Total kW	230.3

Notes:
Country of Origin: Mexico, United States, Saudi Arabia, China

Certified in accordance with the AHRI Air-Cooled Water-Chilling Packages Using Vapor Compression Cycle Certification Program, which is based on AHRI Standard 550/590 (I-P) and AHRI Standard 551/591 (SI). Certified units may be found in the AHRI Directory at www.ahridirectory.org. Auxiliary components included in total kW - Oil heaters, Chiller controls. Auxiliary power is already included in the compressor and fan power



ASHRAE Standard 90.1-2010 and ASHRAE Standard 90.1-2013 & 2016 Compliant.

Compliant with the requirements of the LEED Energy and Atmosphere Enhanced Refrigerant Management Credit (EAc4).

Part Load Rating Data				
Load %	Ambient (°F)	Capacity (ton.R)	Total kW	Unit Efficiency (Btu/W-h)
100	95.0	191.4	230.3	9.975
77	80.1	146.7	122.9	14.32
57	80.1	109.9	91.31	14.44
62	65.1	119.2	80.17	17.84
41	65.1	79.31	53.45	17.81
44	55.0	83.80	49.89	20.16
20	55.0	38.37	22.37	20.58

Sound Power Levels (In Accordance with AHRI 370)										
Load %	Ambient (°F)	63 Hz (dB)	125 Hz (dB)	250 Hz (dB)	500 Hz (dB)	1 kHz (dB)	2 kHz (dB)	4 kHz (dB)	8 kHz (dB)	LWA
100	95.0	97	96	92	92	89	87	83	78	95
77	80.1	97	96	92	92	88	86	82	78	94
57	80.1	96	95	91	91	88	85	81	77	93
62	65.1	96	95	91	91	88	85	81	77	93
41	65.1	95	94	90	90	87	84	80	76	92
44	55.0	95	94	90	90	87	84	80	76	92
20	55.0	89	88	84	84	81	79	75	71	87

Note: Unit is equipped with Ultra Quiet Fans.

Measurement of sound pressure used to obtain the sound power data presented is based on AHRI-370.

Air-cooled chillers are rated in terms of sound power not sound pressure. Johnson Controls provides estimates of sound pressure, but this is not the rating metric.

For an air-cooled chiller, sound pressure calculated from sound power varies depending on how the chiller is assumed to behave, i.e. the radiation model. In other words, determining sound pressure from sound power requires making assumptions that result in different answers at a given distance from the chiller. The environment also influences sound pressure in the field installation. Sound pressure estimation radiation models pertaining to air-cooled chillers include the 'traditional' hemispherical model, parallelepiped model and equivalent hemispherical model.

Regarding sound power, Johnson Controls references tolerance limits based on ASHRAE guidelines. These are +/- 6dB in the 63Hz octave band, +/- 4dB in all other octave bands and +/- 3dB for the overall dBA.

Tolerance limits are based on uncertainties associated with:

1. Measurement Test Procedure
2. Repeatability
3. Production / Manufacturing Variability

Standard deviation associated with air-cooled chiller sound data is a measure of spread i.e. it indicates the range of probability of sound levels. Note that for operating conditions other than AHRI's Standard Rating Condition, higher levels of uncertainty can be expected.

Lead times for factory performance testing depend on test laboratory availability. Please confirm with Johnson Controls Customer Service.

Performance at AHRI Conditions					
Evaporator Data		Condenser Data		Performance Data	
EWT (°F)	54.00	Ambient Temp. (°F)	95.0	EER (Btu/W-h)	10.15
LWT (°F)	44.00	Altitude (ft)	0.000	IPLV.IP (Btu/W-h)	16.92
Flow Rate (USGPM)	467.3			Net Cooling Capacity (ton.R)	195.8
Pressure Drop (ft H2O)	18.9				
Fluid	Water				
Fouling Factor (h.ft ² .F/Btu)	0.000100				
Fluid Volume (USGAL)	12.68				

Note: Unit rated at design condition capacity.

NOTE:

- PLACEMENT ON A LEVEL SURFACE FREE OF OBSTRUCTIONS (INCLUDING SNOW, FOR WINTER OPERATION) OR AIR-CIRCULATION ENSURES RATE PERFORMANCE, RELIABLE OPERATION AND EASE OF MAINTENANCE. SITE RESTRICTIONS MAY COMPROMISED MINIMUM CLEARANCES INDICATED BELOW, RESULTING IN UNPREDICTABLE AIR FLOW PATTERNS AND POSSIBLE DIMINISHED PERFORMANCE. JOHNSON CONTROLS UNIT CONTROLS WILL OPTIMIZE OPERATION WITHOUT NUISANCE HIGH PRESSURE SAFETY CUTOFF. HOWEVER, THE SYSTEM DESIGNER MUST CONSIDER POTENTIAL PERFORMANCE DEGRADATION.

1.1. RECOMMENDED MINIMUM CLEARANCES:

- 1.1.1. SIDE TO WALL - 1828.8mm [72.00]
- 1.1.2. REAR TO WALL - 1828.8mm [72.00]
- 1.1.3. CONTROL PANEL TO WALL - 1219.2mm [48.00]
- 1.1.4. TOP - NO OBSTRUCTIONS ALLOWED.
- 1.1.5. DISTANCE BETWEEN ADJACENT UNITS - 3048mm [120.00]
- 1.1.6. NO MORE THAN ONE ADJACENT WALL MAY BE HIGHER THAN UNIT.

- WEIGHT AND CENTRE OF GRAVITY - REF TO AVM REPORT
- INSTALLING CONTRACTOR MUST INCLUDE VENT AND DRAIN ACCOMMODATIONS IN CHILLED WATER PIPING NEAR EVAPORATOR.
- NUMBER OF COMPRESSORS MAY VARY FROM DRAWING.
 - REFER TO YORKWORKS REPORTS
- FOR MONTERREY, MEXICO AND SAN ANTONIO, TEXAS BUILDS ONLY.

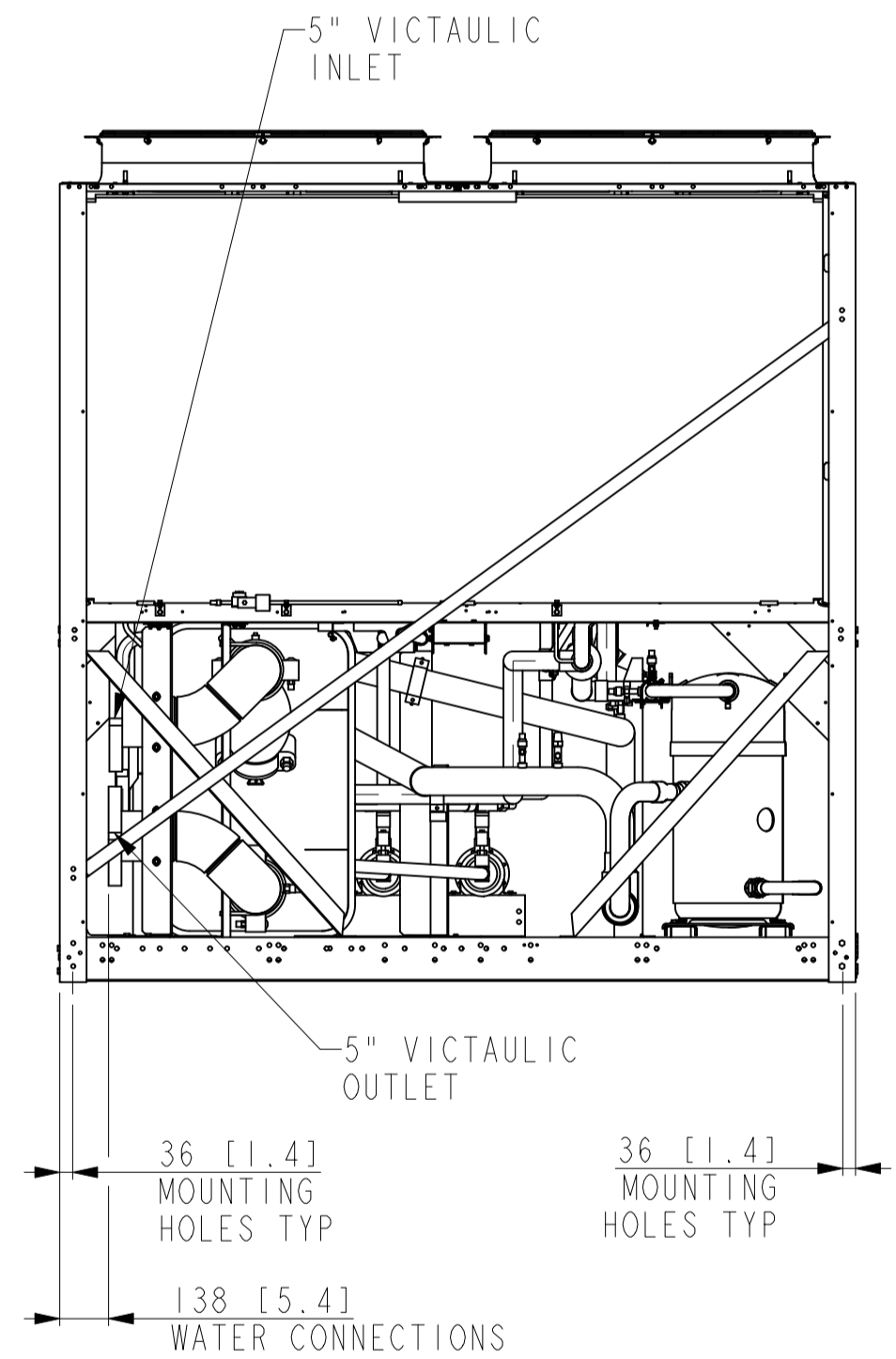
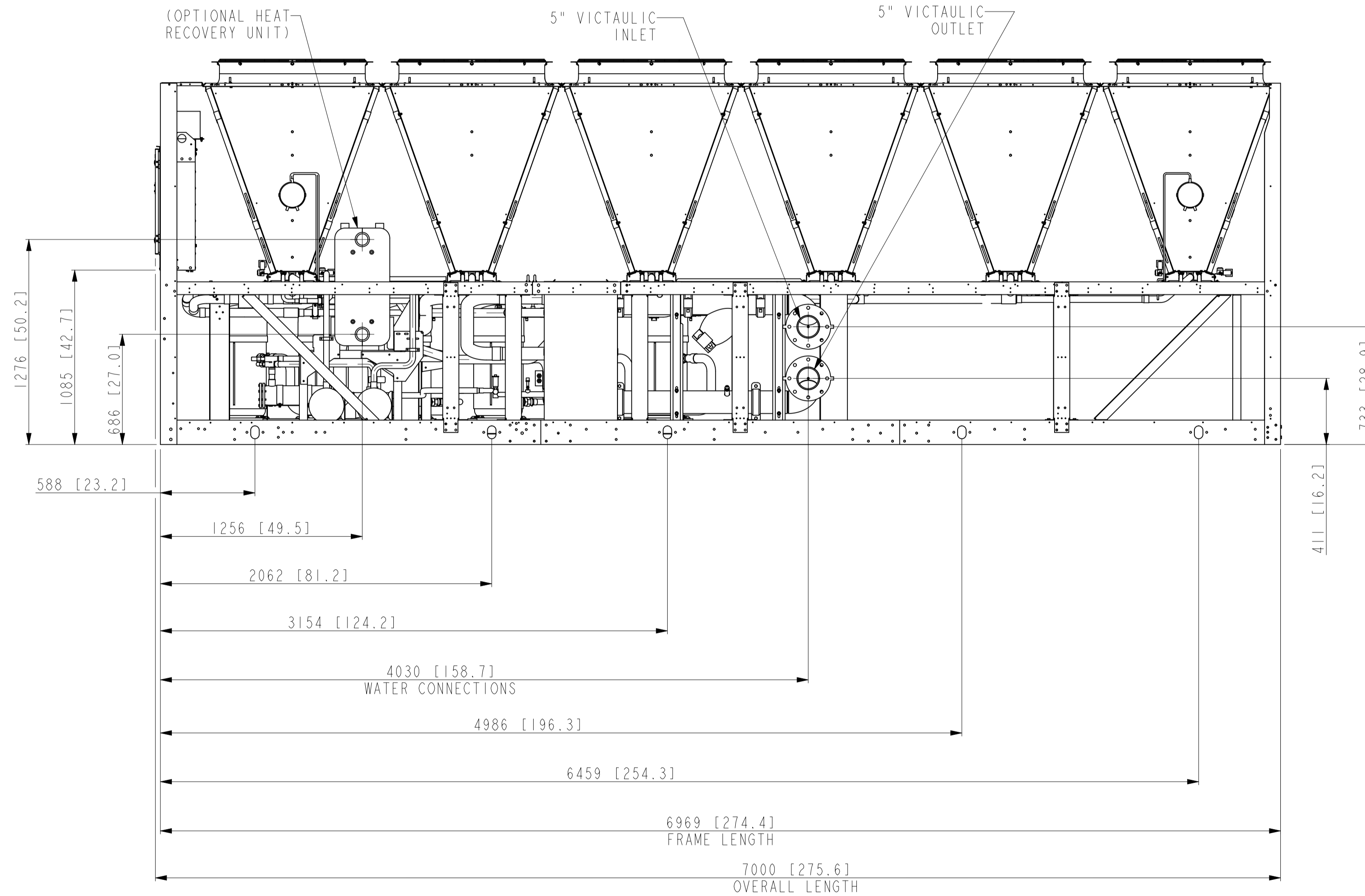
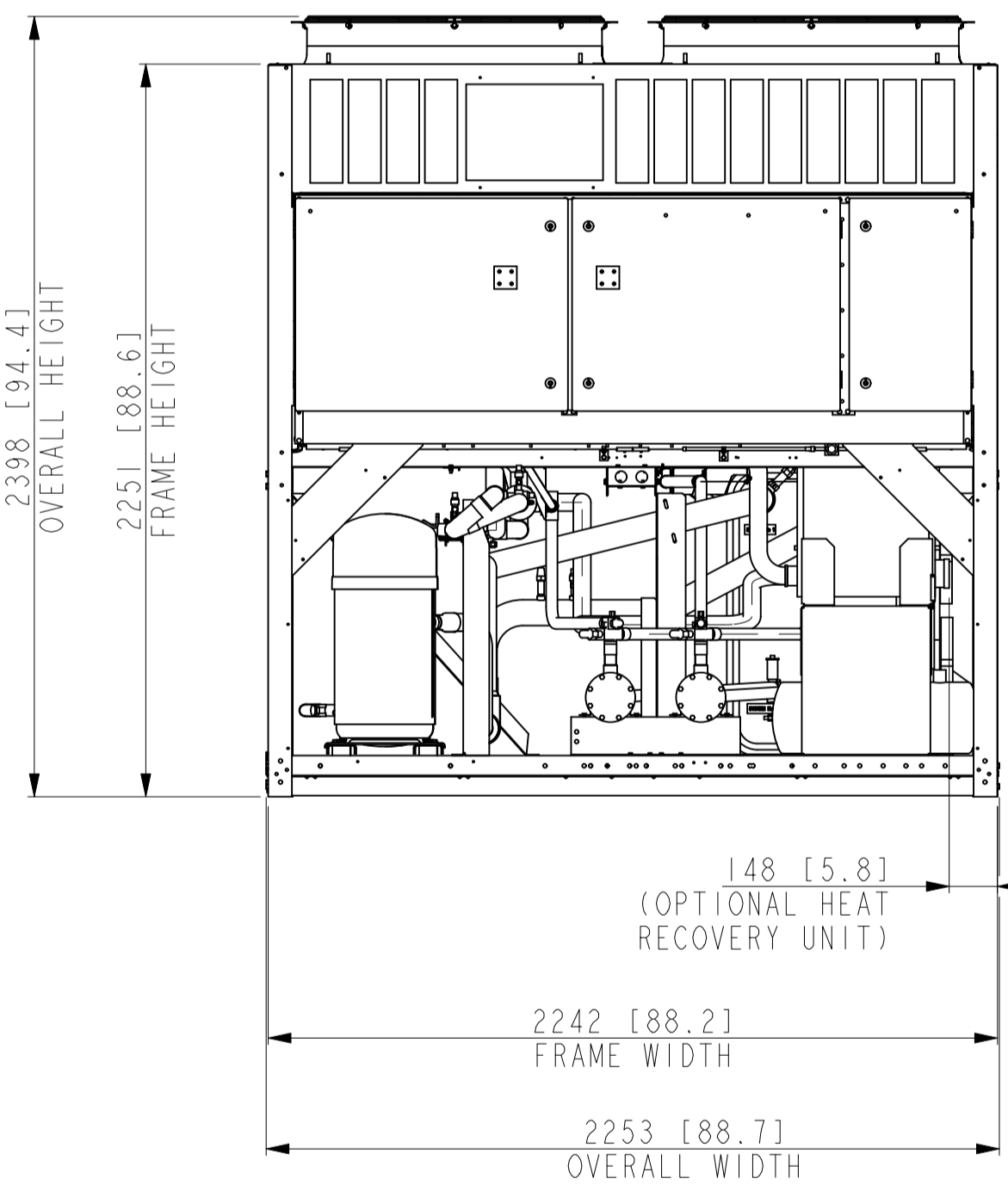
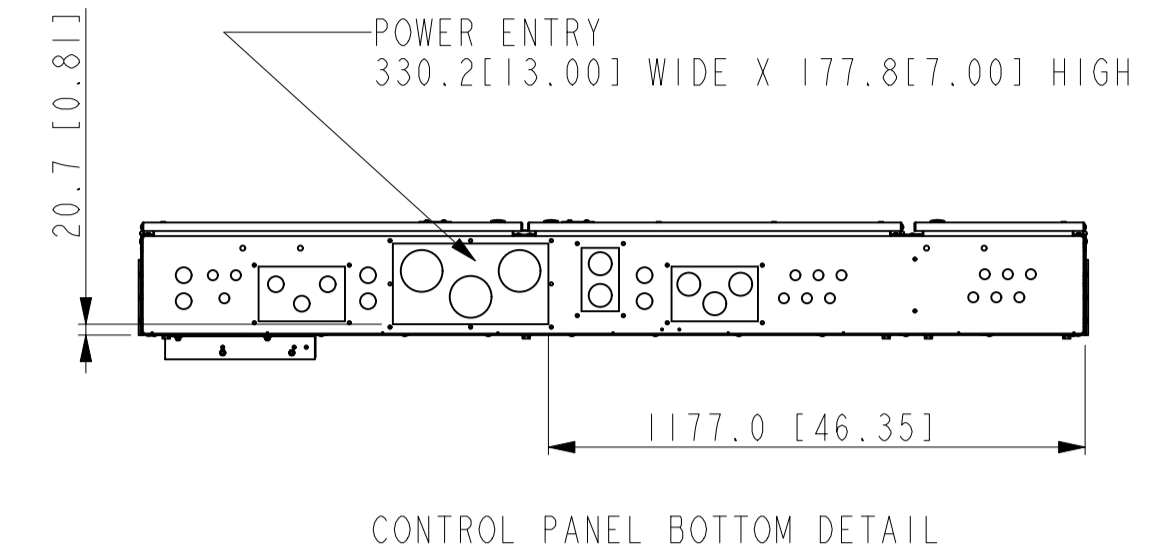
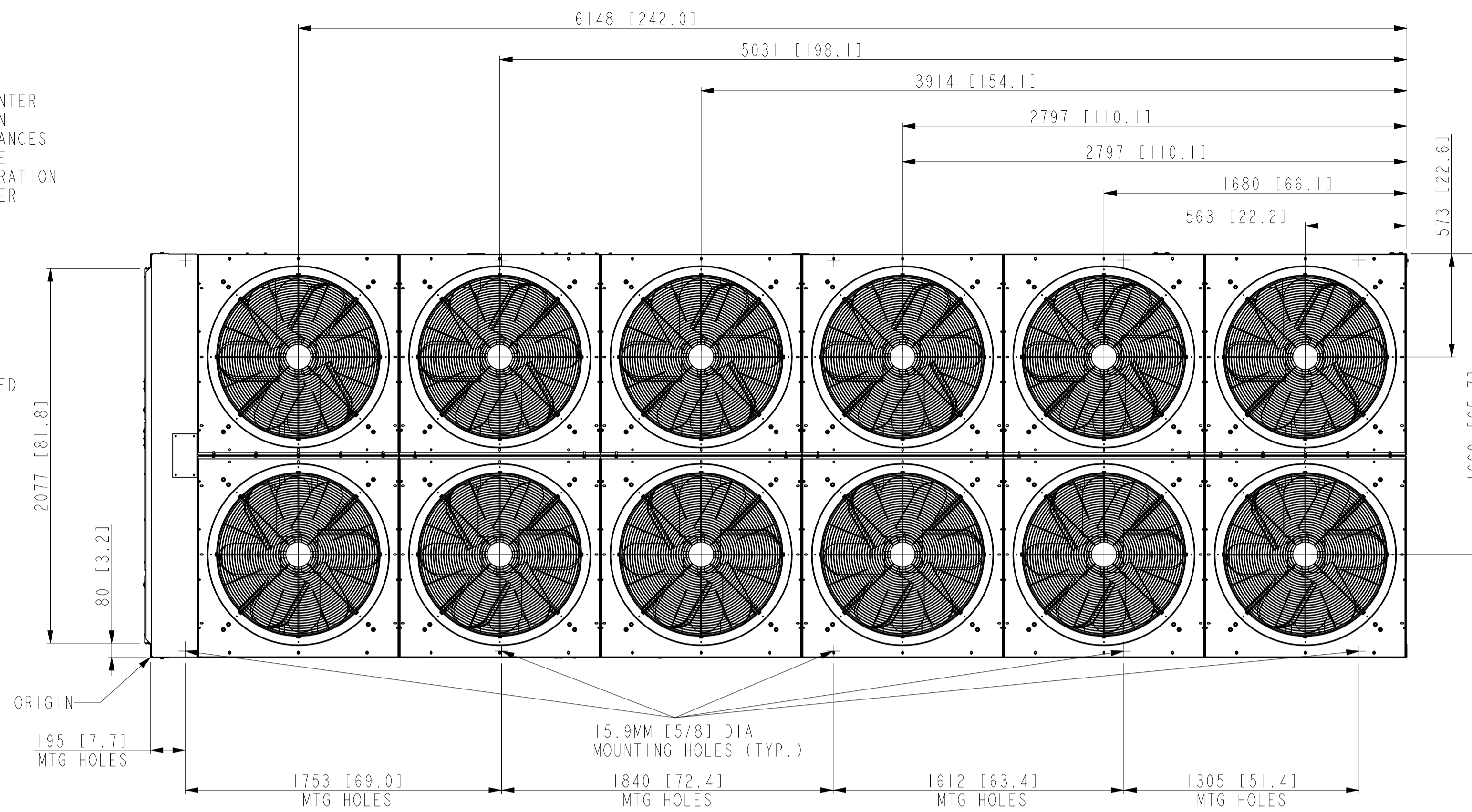

THIS DRAWING PERTAINS TO THE FOLLOWING MODELS:	
YLAA 0200 HE	
YLAA 0230 HE	

REV.	DATE	EC. NO.	DR.	CHK.	ENG.
E	24-AUG-2018	DX18-0330	FJM	FJM	
B13-16; ADDED TABLE, G6; DELETED DIM 2938, C9; ADDED DIM 4030, D1-3 ADDED DIM'S 36, DIM 138 ADDED WATER CONN., 14; DELETED DIM 36.4, B1; DELETED DRAWING TOL BLOCK, J-L 4-10; ADDED DIM'S FOR FAN LOC, B7; DIM 7000 WAS 7006, E-F10; ADDED OPTIONAL HEAT RECOVERY UNIT.					

CONTINUED

ALL PROPRIETARY RIGHTS IN THE SUBJECT MATTER HEREOF ARE RESERVED AND NO PERMISSION IS GRANTED TO REPRODUCE THIS PRINT IN WHOLE OR IN ANY PART, OR DISCLOSE ANY OF THE INFORMATION UPON IT TO OTHERS WITHOUT WRITTEN RELEASE BY JOHNSON CONTROLS INCORPORATED

		JOHNSON CONTROLS - BUILDING EFFICIENCY 507 EAST MICHIGAN STREET, MILWAUKEE, WI, 53202 USA	
THIRD ANGLE DO NOT SCALE	YLAA 12-FAN 60HZ 0200 & 0230 WITH OPTIONAL HEAT RECOVERY	MATERIAL - ENG. STD. - PART NO. - CUT SIZE N/A	REVISION E VERSION 0 Eng Chg
DRAWN M. LUPTON 19-FEB-2016	MODELER M. LUPTON 19-FEB-2016	A CAGE NUMBER 66935	DRAWING NUMBER 035-24059-014
CHKD A. SAYCH 19-FEB-2016	ENG A. KELLY 19-FEB-2016	SCALE: 0.050 MASS (kg): 0.000	ORIG. NO.: - SHEET 1 OF 1

Project Name	Unit Tag	Date	Chiller Type
NewProject	CH-01	2022-07-07	Air Cooled Scroll Chillers
PIN			Version
YLA0200HE46XFBBCTXASXBLXCXX42SE1XXXHXXYAXGTXX7XXXLGNF1XXXX			E.21.5.28027.0-D.94.0010

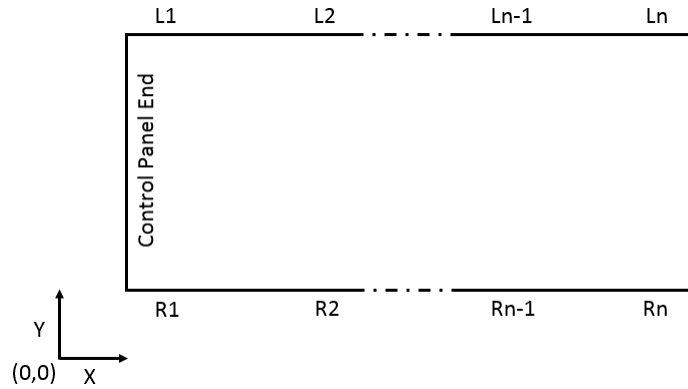

LOCATION	X Distance (in)	Y Distance (in)	Vendor Isolator Part Number	COLOUR	Operating Weights (lb)
R1	7.7	1.4	029-25335-001(434002)	Charcoal	683
R2	76.7	1.4	029-25335-002(434004)	Red	1246
R3	149.1	1.4	029-25335-002(434004)	Red	1149
R4	212.5	1.4	029-25335-001(434002)	Charcoal	428
R5	263.9	1.4	029-25335-001(434002)	Charcoal	787
L1	7.7	86.9	029-25335-002(434004)	Red	1065
L2	76.7	86.9	029-25335-004(434005)	Charcoal	2222
L3	149.1	86.9	029-25335-002(434004)	Red	1371
L4	212.5	86.9	029-25335-001(434002)	Charcoal	428
L5	263.9	86.9	029-25335-001(434002)	Charcoal	785

Total Weight (lb)		Centre of Gravity (in)	
Operating	10163	Xg	123.2
Shipping	10033	Yg	50.8

Wiring Diagram

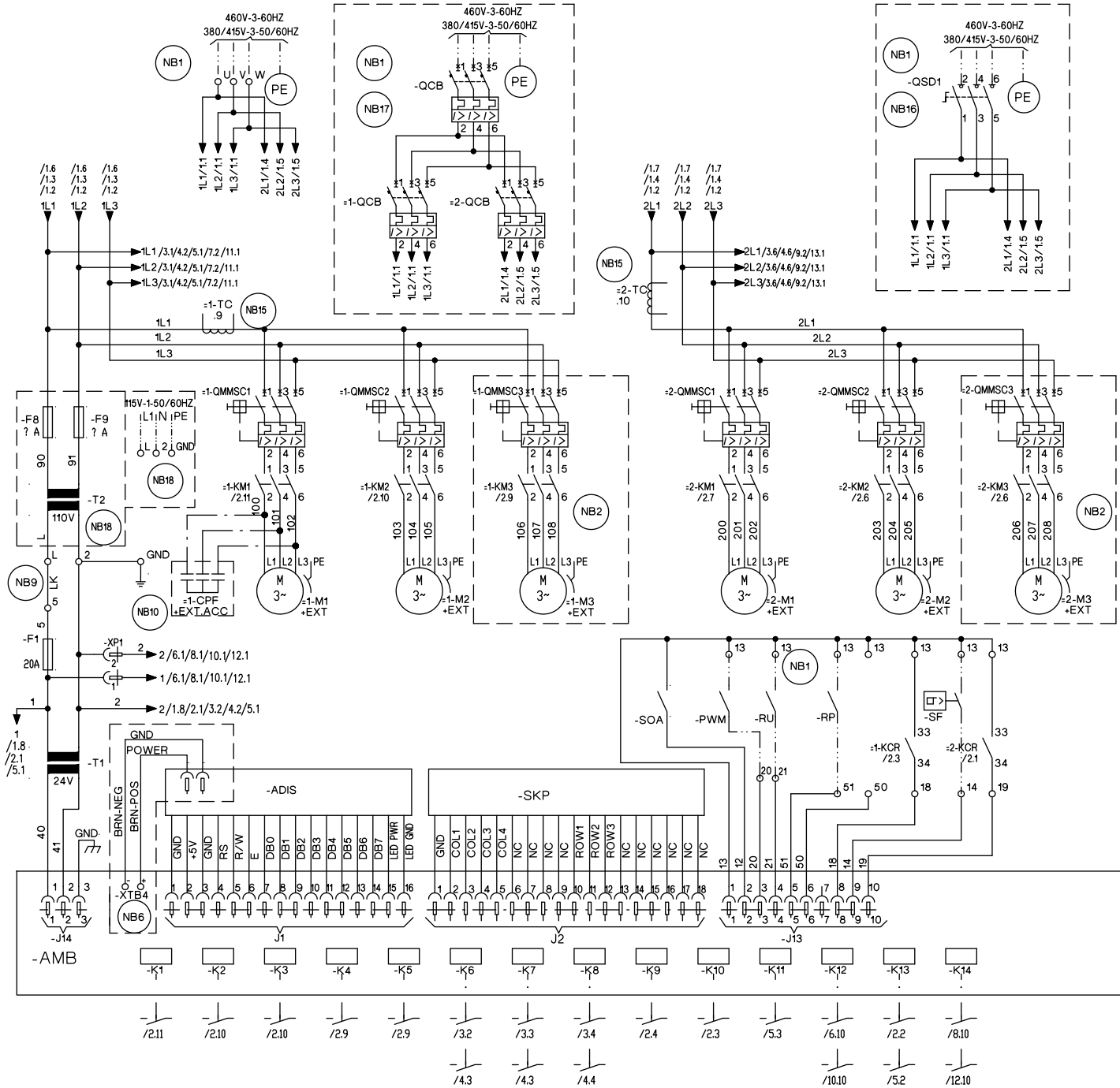

Wiring Diagram (Cont'd)

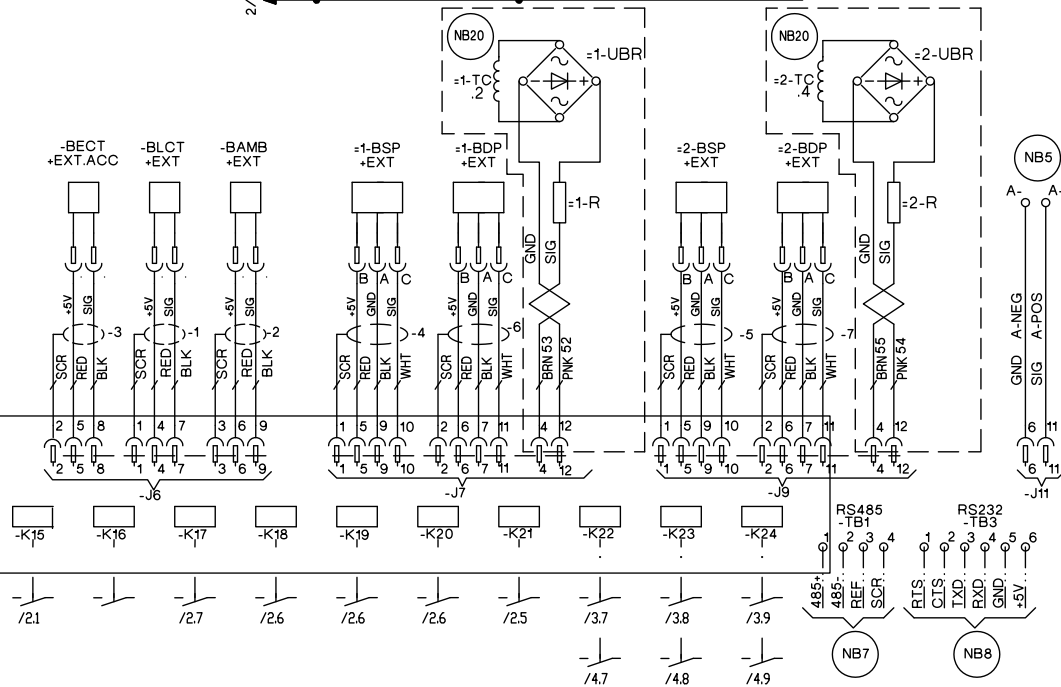
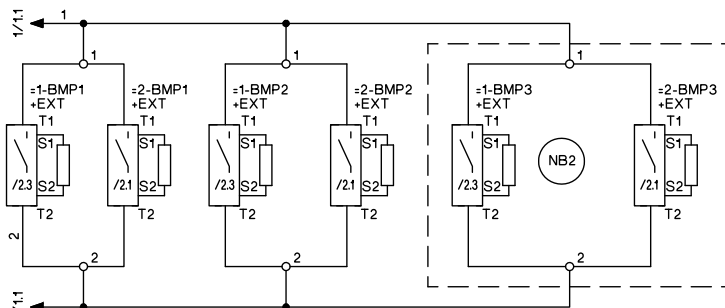
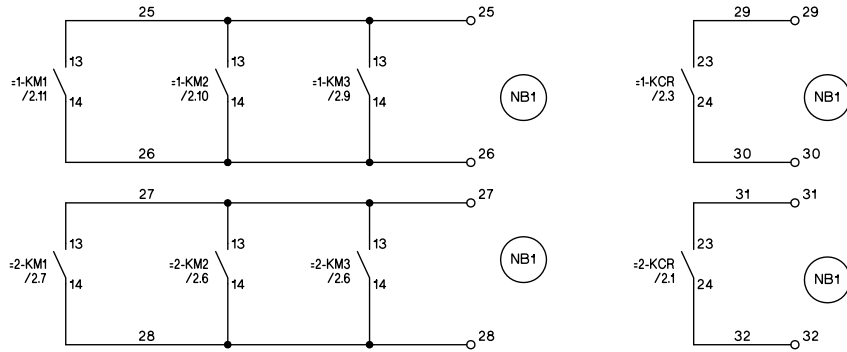

LD18444

Wiring Diagram (Cont'd)

Designation	DESCRIPTION
ACC	ACCESSORY
- ADIS	DISPLAY BOARD
- AMB	MICRO BOARD

- BAMB	AMBIENT
- BDP	DISCHARGE PRESSURE
- BECT	ENTERING CHILLED TEMP
- BLCT	LEAVING CHILLED TEMPERATURE
NOT FITTED ON REMOTE EVAP UNITS	

-BMP	MOTOR PROTECTOR COMP
- BSP	SUCTION PRESSURE

-CPF	CAPACITOR POWER FACTOR
------	------------------------

- ECH	CRANKCASE HEATER
-EEH	EVAPORATOR HEATER
-EPH	PUMP HEATER
-EXT	EXTERNAL TO CONTROL PANEL

- F	FUSE
- FHP	HIGH PRESSURE CUTOUT
-FSI	FAN SPEED INHIBIT TWO SPEED FAN OPTION ONLY

GND	GROUND
G/Y	GREEN / YELLOW

J	PLUG BOARD CONNECTOR
---	----------------------

-K	CIRCUIT BOARD RELAY
-KF	FAN CONTACTOR LINE
-KFH	FAN CONTACTOR HIGH SPEED (INCLUDING COIL SUPPRESSOR)
-KFL	FAN CONTACTOR LOW SPEED (INCLUDING COIL SUPPRESSOR)
-KFOL	FAN OVERLOAD
-KFS	RELAY FAN SPEED
-KM	COMPRESSOR CONTACTOR (INCLUDING COIL SUPPRESSOR)
-KCR	CONTROL RELAY
-KP	PUMP CONTACTOR PART (INCLUDING COIL SUPPRESSOR)

- M	COMPRESSOR MOTOR
-MF	MOTOR FAN
-MP	MOTOR PUMP

NU	NOT USED
----	----------

PE	PROTECTIVE EARTH
PWM	PULSE WIDTH MODULATION TEMP RESET or REMOTE UNLOAD 2nd STEP

Designation	DESCRIPTION
-QCB	CIRCUIT BREAKER
-QMMS	MANUAL MOTOR STARTER COMP
-QMSP	MANUAL MOTOR STARTER PUMP
-QSD	SWITCH DISCONNECT

R	RESISTOR
RED	RED
RP	RUN PERMISSIVE
RU	REMOTE UNLOAD 1st STEP

CR	SCREEN
- SF	FLOW SWITCH
- SKP	KEYPAD
- SOA	SWITCH OFF AUTO

- T	TRANSFORMER
-TC	TRANSFORMER CURRENT

-UBR	BRIDGE RECTIFIER
------	------------------

WHT	WHITE
-----	-------

- XTBC	TERMINAL BLOCK CUSTOMER
- XTBF	TERMINAL BLOCK FACTORY

-YHGSV	HOT GAS SOLENOID VALVE (INCLUDING COIL SUPPRESSOR)
- YLLSV	LIQUID LINE SOLENOID VALVE (INCLUDING COIL SUPPRESSOR)
FIELD MOUNTED AND WIRED ON REMOTE EVAP UNITS	

- ZCPR	COMPRESSOR
--------	------------

	NOTE WELL {SEE NOTE}
---	----------------------

	WIRING AND ITEMS SHOWN THUS ARE STANDARD YORK ACCESSORIES
---	--

	WIRING AND ITEMS SHOWN THUS ARE NOT SUPPLIED BY JOHNSON CONTROLS
---	---

	ITEMS THUS ENCLOSED FORM A COMPONENTS OR SETS OF COMPONENTS
---	--

Wiring Diagram (Cont'd)

- A. This drawing is based on IEC symbols.
 - B. Field wiring to be in accordance with the relevant electrical code as well as all other applicable codes and specifications.
 - C. All sources of supply shown on this diagram to be taken from one main isolator, not shown or supplied by the chiller manufacturer.
 - D. Green and yellow wire is used for earth, multi-coloured cable used for low voltage. Red wire used for AC control, blue wire for neutral, black wire for AC and DC power. Orange wire should be used for interlock control wiring supplied by external source.
 - E. Legend designation depicts component abbreviations. Number prefix located, if applicable, on schematic circuit, refers to system thereon, e.g.= 1-FHP2 refers to high pressure cutout no 2 on system no 1.
 - F. All wiring to control section voltage free contacts requires a supply provided by the customer maximum voltage 240 volts. The customer must take particular care when deriving the supplies for the voltage free terminals with regard to a common point of isolation. Thus, these circuits when used must be fed via the common point of isolation the voltage to these circuits is removed when the common point of isolation to the unit is opened. This common point of isolation is not supplied. The voltage free contacts are rated at 100VA. All inductive devices {relays} switch by the voltage free contacts must have their coil suppressed using standard r/c suppressors.
 - G. Customer voltage free contacts connected to terminal 13 must be rated at 30 V 5 mA.
 - H. No controls {relays etc.} Should be mounted in any section of the control panel. Additionally, control wiring not connected to the control panel should not be run through the panel. If these precautions are not followed, electrical noise could cause malfunctions or damage to the unit and its controls.
1. Refer to installation commissioning operation and maintenance manual for customer connections and customer connection notes, non compliance to these instructions will invalidate unit warranty.
 2. Wiring and components for compressor 3 only fitted when unit has 3 compressors on the system. 1-BMP3 is replaced by a link across terminals 134 & 135. 2-BMP3 is replaced by a link across terminals 234 & 235.
 3. FHP2 is only fitted on 0089 and above. When not fitted 1-FHP2 is replaced by a link across terminals 132 & 139. 2-FHP2 is replaced by a link across terminals 232 & 239.
 4. Fitted on units with hot gas bypass option.
 5. EMS option is wired as shown.
 6. This wiring must be used for old display 031-0110-000.
 7. Network connection point.
 8. Printer port.
 9. Remote emergency stop can be wired between terminal 1 and 5 after removing link.
 10. Power factor correction accessory. Power factor correction fitted to each compressor contactor.
 11. Not fitted on compressors with internal motor protection. For system 1 terminals 132 & 133, 133 & 134 And 134 & 135 are linked. For system 2 terminals 232 & 233, 233 & 234 and 234 & 235 are linked.
 12. Only fitted on systems with 3 or 4 fans.
 13. Only fitted on systems with 4 fans.
 14. Only fitted on systems with 5 fans.
 15. Only fitted on systems with 6 fans.
 16. Input switch disconnect or circuit breaker option replaces input terminal block.
 17. Input switch disconnect & system circuit breaker option replaces input terminal block.
 18. 115V control circuit requires a 115V supply unless control circuit transformer-T2 & -F3 are fitted.
 19. For optional hydro kit. Heater -EPH is fitted and wired as shown. On single pump -KP1, -QMMSP1 and -MP1 are fitted & wired as shown. On two pump hydro kits -KP2, -QMMSP2 & -MP2 are also fitted and wired as shown.
 20. Current measurement option wired as shown.
 21. Only fitted on systems with single speed fans.
 22. Only fitted on systems with two speed fans.
 23. Optional compressor manual motors starters.
 24. See sheet 3 of connection diagram for power input options.

User Control Wiring

USER CONTROL WIRING INPUTS

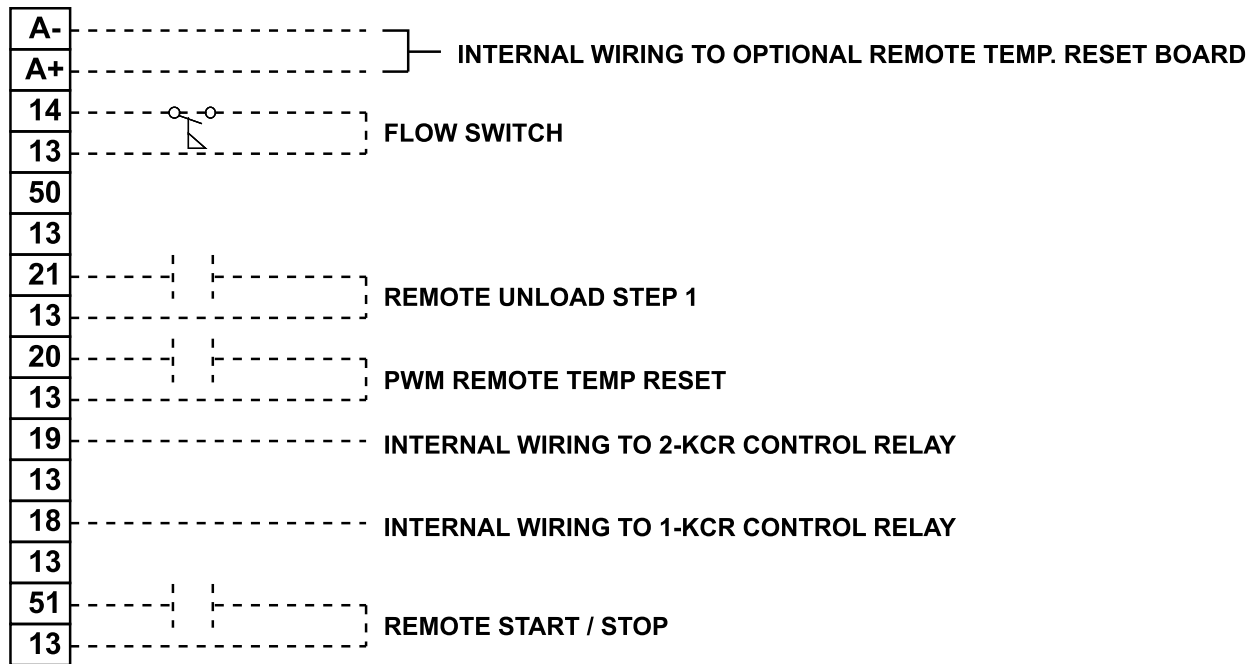

XTBC1

USER CONTROL WIRING OUTPUTS

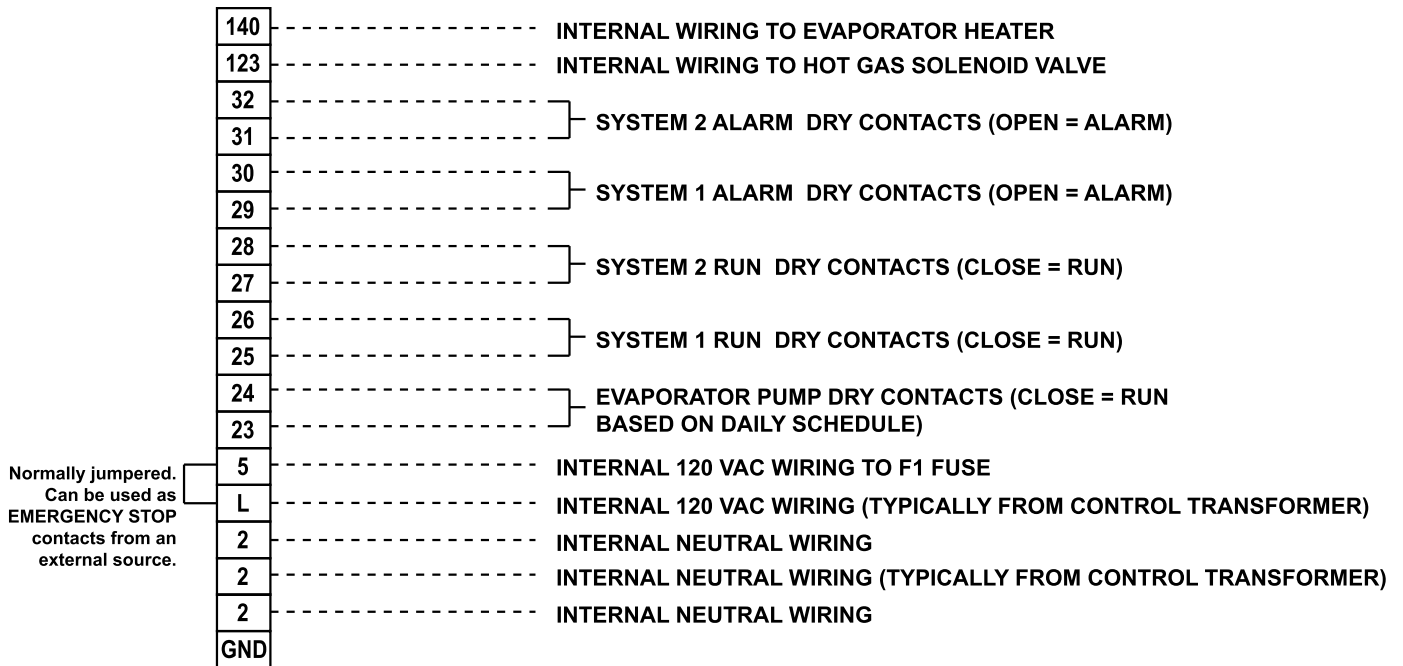

XTBC2

SCROLL CHILLER/HEATPUMP/CONDENSING UNIT					York Talk 2 (eLink)	Board: 031-02550
Item	Version	York P/N	Baud	Comments		
1	C.MMC.13.05, C.MMC.14.05, C.MMC.16.07	031-02755-001, -003	4800	New		
2	C.MMC.13.11, C.MMC.14.11, C.MMC.16.11	031-02755-001, -003	4800	Update: add SCC, section 2		
3	C.MMC.16.12	031-02755-004	4800	Update: -004 release		
4	C.MMC.13.19, C.MMC.14.19, C.MMC.16.19	031-02755-001, -003	4800	Update: V14 add op code 19 and fault code 31; V18 R-454B added as selection Section 2, P56		
5	C.MMC.13.23, C.MMC.14.23, C.MMC.16.23	031-02755-001, -003	4800	Update: V21 Move Bivalent Heat Step from P43 to P80, Tray heater removed; V23 add fault code 32		
6						
7						
8						
9						
10						

SECTION 1

Eng Page Ref	BACnet Object Typ/Ins	BACnet Object Name	LON Profile Name	LON SNVT Type	N2 Metasys	Modbus		Engineering Units		Point List Code: S = Standard O = Optional N = Not Available	Point List Description										
						Address	Scale	Imperial	SI		1	2	3	4	5	6	7	8	9	10	
P03	AV1	YT2_S01_P03	nviYTS01p003	SNVT_count_f (51)	ADF 1	0001	x10	°F PSI	°C BAR	Remote Setpoint [99=Auto] Sys 1 Remote Setpoint (SP Unit)	S	S	S	S	S						
P04	AV2	YT2_S01_P04	nviYTS01p004	SNVT_count_f (51)	ADF 2	0002	x1	None	None	Load Limit Stage [0, 1, 2] Sys 1 Load Limit Stage [0, 1, 2]	S	S	S	S	S						
P05	AV3	YT2_S01_P05	nviYTS01p005	SNVT_count_f (51)	ADF 3	0003	x10	°F °F PSI	°C °C BAR	Remote Heating Setpoint (HP or YCWL HP) Remote Cooling Range (DAT Unit) Sys 2 Remote Setpoint (SP Unit)	O	O	O	O	O						
P06	AV4	YT2_S01_P06	nviYTS01p006	SNVT_count_f (51)	ADF 4	0004	x1	None	None	Remote Heatpump Mode [0=Pnl, 1=Cool, 2=Heat] (HP or YCWL HP) Sys 2 Load Limit Stage [0, 1, 2]	O	O	O	O	O						
P07	BV1	YT2_S01_P07	nviYTS01p007	SNVT_switch (95)	BD 1	0061	N/A	0/1	0/1	Start/Stop Command Sys 1 Start/Stop Command	S	S	S	S	S						
P08	BV2	YT2_S01_P08	nviYTS01p008	SNVT_switch (95)	BD 2	0062	N/A	0/1	0/1	Sys 2 Start/Stop Command	O	O	O	O	O						
P09	BV3	YT2_S01_P09	nviYTS01p009	SNVT_switch (95)	BD 3	0063					N	N	N	N	N						
P10	BV4	YT2_S01_P10	nviYTS01p010	SNVT_switch (95)	BD 4	0064	N/A	0/1	0/1	History Buffer Request	S	S	S	S	S						
P11	AV5	YT2_S01_P11	nvoYTS01p011	SNVT_count_f (51)	ADF 5	0005	x10	°F	°C	Leaving Chiller Liquid Temp	S	S	S	S	S						
P12	AV6	YT2_S01_P12	nvoYTS01p012	SNVT_count_f (51)	ADF 6	0006	x10	°F	°C	Entering Chilled Liquid Temp	S	S	S	S	S						
P13	AV7	YT2_S01_P13	nvoYTS01p013	SNVT_count_f (51)	ADF 7	0007	x10	°F	°C	Leaving Liquid Temp Hot (YCWL)	O	O	O	O	O						
P14	AV8	YT2_S01_P14	nvoYTS01p014	SNVT_count_f (51)	ADF 8	0008	x10	°F	°C	Discharge Air Temp (Cond Unit) Entering Liquid Temp Hot (YCWL)	O	O	O	O	O						
P15	AV9	YT2_S01_P15	nvoYTS01p015	SNVT_count_f (51)	ADF 9	0009	x10	°F	°C	Sys 1 Suction Temperature (EEV)	O	O	O	O	O						
P16	AV10	YT2_S01_P16	nvoYTS01p016	SNVT_count_f (51)	ADF 10	0010	x10	°F	°C	Ambient Air Temperature	S	S	S	S	S						
P17	AV11	YT2_S01_P17	nvoYTS01p017	SNVT_count_f (51)	ADF 11	0011	x10	°F (diff)	°C (diff)	Sys 1 Suction Superheat (EEV)	O	O	O	O	O						
P18	AV12	YT2_S01_P18	nvoYTS01p018	SNVT_count_f (51)	ADF 12	0012	x1	None	None	Sys 1 Run Time in seconds	S	S	S	S	S						
P19	AV13	YT2_S01_P19	nvoYTS01p019	SNVT_count_f (51)	ADF 13	0013	x10	PSI	BAR	Sys 1 Suction Pressure	S	S	S	S	S						
P20	AV14	YT2_S01_P20	nvoYTS01p020	SNVT_count_f (51)	ADF 14	0014	x10	PSI	BAR	Sys 1 Discharge Pressure	S	S	S	S	S						
P21	AV15	YT2_S01_P21	nvoYTS01p021	SNVT_count_f (51)	ADF 15	0015	x10	°F	°C	Sys 1 Suction Temperature (Cond Unit) Sys 1 Cooler Inlet Refrigerant Temp (R-407c)	O	O	O	O	O						
P22	AV16	YT2_S01_P22	nvoYTS01p022	SNVT_count_f (51)	ADF 16	0016	x10	°F	°C	Sys 1 Defrost Temperature (HP)	O	O	O	O	O						
P23	AV17	YT2_S01_P23	nvoYTS01p023	SNVT_count_f (51)	ADF 17	0017	x10	%	%	Sys 1 EEV Output % (EEV)	O	O	O	O	O						
P24	AV18	YT2_S01_P24	nvoYTS01p024	SNVT_count_f (51)	ADF 18	0018	x1	None	None	Sys 1 Anti-Recycle Timer	S	S	S	S	S						
P25	AV19	YT2_S01_P25	nvoYTS01p025	SNVT_count_f (51)	ADF 19	0019	x1	None	None	Anti-Coincident Timer in seconds	S	S	S	S	S						
P26	AV20	YT2_S01_P26	nvoYTS01p026	SNVT_count_f (51)	ADF 20	0020	x10	°F	°C	Sys 2 Suction Temperature (EEV)	O	O	O	O	O						

Eng Page Ref	BACnet Object Typ/Ins	BACnet Object Name	LON Profile Name	LON SNVT Type	N2 Metasys	Modbus		Engineering Units		Point List Code: S = Standard O = Optional N = Not Available											
						Address	Scale	Imperial	SI	Point List Description											
										1	2	3	4	5	6	7	8	9	10		
P70	AV34	YT2_S01_P70	nvoYTS01p070	SNVT_count_f(51)	ADF 34	0044	x10	PSI	BAR	Low Suction Pressure Cutout Cooling	S	S	S	S	S						
P71	AV35	YT2_S01_P71	nvoYTS01p071	SNVT_count_f(51)	ADF 35	0045	x10	PSI	BAR	High Discharge Pressure Cutout	S	S	S	S	S						
P72	AV36	YT2_S01_P72	nvoYTS01p072	SNVT_count_f(51)	ADF 36	0046	x10	°F	°C	Remote Setpoint	S	S	S	S	S						
P73	AV37	YT2_S01_P73	nvoYTS01p073	SNVT_count_f(51)	ADF 37	0047	x10	°F	°C	Cooling Range	S	S	S	S	S						
P74	AV38	YT2_S01_P74	nvoYTS01p074	SNVT_count_f(51)	ADF 38	0048	x10	PSI °F	BAR °C	Remote Setpoint 2 (SP) Remote Heating Setpoint (HP and YCWL HP)	O	O	O	O	O						
P75	AV39	YT2_S01_P75	nvoYTS01p075	SNVT_count_f(51)	ADF 39	0049	x10	PSI °F	BAR °C	Cooling Range 2 (SP) Heating Range (HP and YCWL HP)	O	O	O	O	O						
P76	AV40	YT2_S01_P76	nvoYTS01p076	SNVT_count_f(51)	ADF 40	0050	x10	°F	°C	Sys 1 Discharge Temperature (EEV)	O	O	O	O	O						
P77	AV41	YT2_S01_P77	nvoYTS01p077	SNVT_count_f(51)	ADF 41	0051	x10	°F (diff)	°C (diff)	Sys 1 Discharge Superheat (EEV)	O	O	O	O	O						
P78	AV42	YT2_S01_P78	nvoYTS01p078	SNVT_count_f(51)	ADF 42	0052	x10	°F	°C	Sys 2 Discharge Temperature (EEV)	O	O	O	O	O						
P79	AV43	YT2_S01_P79	nvoYTS01p079	SNVT_count_f(51)	ADF 43	0053	x10	°F (diff)	°C (diff)	Sys 2 Discharge Superheat (EEV)	O	O	O	O	O						
P80	BV25	YT2_S01_P80	nvoYTS01p080	SNVT_switch(95)	BD 25	0085	N/A	0/1	0/1	Bivalent Heat Step (YLAE HP) Compressor Heater (R-410a/R-454B chillers, YCWL chillers)	N	N	N	N	O						
P81	BV26	YT2_S01_P81	nvoYTS01p081	SNVT_switch(95)	BD 26	0086					N	N	N	N	N						
P82	BV27	YT2_S01_P82	nvoYTS01p082	SNVT_switch(95)	BD 27	0087					N	N	N	N	N						
P83	BV28	YT2_S01_P83	nvoYTS01p083	SNVT_switch(95)	BD 28	0088					N	N	N	N	N						
P84	BV29	YT2_S01_P84	nvoYTS01p084	SNVT_switch(95)	BD 29	0089	N/A	0/1	0/1	SCC Auto Detect Available	N	S	S	S	S						

Eng Page Ref	BACnet Object Typ/Ins	BACnet Object Name	LON Profile Name	LON SNVT Type	N2 Metasys	Modbus		Engineering Units		Point List Code: S = Standard O = Optional N = Not Available										
						Address	Scale	Imperial	SI	Point List Description										
											1	2	3	4	5	6	7	8	9	10
P48	BV117	YT2_S02_P48	nvoYTS02p048	SNVT_switch (95)	BD 46	0177	N/A	0/1	0/1	YCWL Mode [0=Chiller, 1=Heatpump]										
P49	BV118	YT2_S02_P49	nvoYTS02p049	SNVT_switch (95)	BD 47	0178				N	O	O	O	O						
P50	BV119	YT2_S02_P50	nvoYTS02p050	SNVT_switch (95)	BD 48	0179	N/A	0/1	0/1	SCC Auto Detect Digit 1										
P51	BV120	YT2_S02_P51	nvoYTS02p051	SNVT_switch (95)	BD 49	0180	N/A	0/1	0/1	SCC Auto Detect Digit 2										
P52	BV121	YT2_S02_P52	nvoYTS02p052	SNVT_switch (95)	BD 50	0181	N/A	0/1	0/1	SCC Auto Detect Digit 3										
P53	BV122	YT2_S02_P53	nvoYTS02p053	SNVT_switch (95)	BD 51	0182	N/A	0/1	0/1	SCC Auto Detect Digit 4										
P54	BV123	YT2_S02_P54	nvoYTS02p054	SNVT_switch (95)	BD 52	0183	N/A	0/1	0/1	SCC Auto Detect Digit 5										
P55	BV124	YT2_S02_P55	nvoYTS02p055	SNVT_switch (95)	BD 53	0184	N/A	0/1	0/1	SCC Auto Detect Digit 6										
P56	MV101	YT2_S02_P56	nvoYTS02p056	SNVT_count_f (51)	ADI 25	0130	x1	None	None	Refrigerant [0=R-22, 1=R-407c, 2=R-410a, 3=R-454B]										
P57	MV102	YT2_S02_P57	nvoYTS02p057	SNVT_count_f (51)	ADI 26	0131				N	N	N	N	N						
P58	MV103	YT2_S02_P58	nvoYTS02p058	SNVT_count_f (51)	ADI 27	0132				N	N	N	N	N						
P59	MV104	YT2_S02_P59	nvoYTS02p059	SNVT_count_f (51)	ADI 28	0133				N	N	N	N	N						
P60	MV105	YT2_S02_P60	nvoYTS02p060	SNVT_count_f (51)	ADI 29	0134				N	N	N	N	N						
P61	MV106	YT2_S02_P61	nvoYTS02p061	SNVT_count_f (51)	ADI 30	0135				N	N	N	N	N						
P62	MV107	YT2_S02_P62	nvoYTS02p062	SNVT_count_f (51)	ADI 31	0136				N	N	N	N	N						
P63	MV108	YT2_S02_P63	nvoYTS02p063	SNVT_count_f (51)	ADI 32	0137				N	N	N	N	N						
P64	MV109	YT2_S02_P64	nvoYTS02p064	SNVT_count_f (51)	ADI 33	0138				N	N	N	N	N						
P65	MV110	YT2_S02_P65	nvoYTS02p065	SNVT_count_f (51)	ADI 34	0139				N	N	N	N	N						
P66	AV130	YT2_S02_P66	nvoYTS02p066	SNVT_count_f (51)	ADF 73	0140				N	N	N	N	N						
P67	AV131	YT2_S02_P67	nvoYTS02p067	SNVT_count_f (51)	ADF 74	0141				N	N	N	N	N						
P68	AV132	YT2_S02_P68	nvoYTS02p068	SNVT_count_f (51)	ADF 75	0142				N	N	N	N	N						
P69	AV133	YT2_S02_P69	nvoYTS02p069	SNVT_count_f (51)	ADF 76	0143				N	N	N	N	N						
P70	AV134	YT2_S02_P70	nvoYTS02p070	SNVT_count_f (51)	ADF 77	0144				N	N	N	N	N						
P71	AV135	YT2_S02_P71	nvoYTS02p071	SNVT_count_f (51)	ADF 78	0145				N	N	N	N	N						
P72	AV136	YT2_S02_P72	nvoYTS02p072	SNVT_count_f (51)	ADF 79	0146				N	N	N	N	N						
P73	AV137	YT2_S02_P73	nvoYTS02p073	SNVT_count_f (51)	ADF 80	0147				N	N	N	N	N						
P74	AV138	YT2_S02_P74	nvoYTS02p074	SNVT_count_f (51)	ADF 81	0148				N	N	N	N	N						
P75	AV139	YT2_S02_P75	nvoYTS02p075	SNVT_count_f (51)	ADF 82	0149				N	N	N	N	N						
P76	AV140	YT2_S02_P76	nvoYTS02p076	SNVT_count_f (51)	ADF 83	0150				N	N	N	N	N						
P77	AV141	YT2_S02_P77	nvoYTS02p077	SNVT_count_f (51)	ADF 84	0151				N	N	N	N	N						
P78	AV142	YT2_S02_P78	nvoYTS02p078	SNVT_count_f (51)	ADF 85	0152				N	N	N	N	N						
P79	AV143	YT2_S02_P79	nvoYTS02p079	SNVT_count_f (51)	ADF 86	0153				N	N	N	N	N						
P80	BV125	YT2_S02_P80	nvoYTS02p080	SNVT_switch (95)	BD 54	0185				N	N	N	N	N						
P81	BV126	YT2_S02_P81	nvoYTS02p081	SNVT_switch (95)	BD 55	0186				N	N	N	N	N						
P82	BV127	YT2_S02_P82	nvoYTS02p082	SNVT_switch (95)	BD 56	0187				N	N	N	N	N						
P83	BV128	YT2_S02_P83	nvoYTS02p083	SNVT_switch (95)	BD 57	0188				N	N	N	N	N						
P84	BV129	YT2_S02_P84	nvoYTS02p084	SNVT_switch (95)	BD 58	0189	N/A	0/1	0/1	Units [0=Imperial, 1=Metric]										

NOTES	
1	LON SNVTs used: SNVT_count_f (51) and SNVT_switch (95). Must use LON eLink.
2	Modbus scaling factors indicated in bold with an asterisk (*) are user configurable by a field technician, if necessary. All Modbus values are of the type SIGNED with the exception of the user configurable values that are all UNSIGNED. Modbus function types supported: ENG P03-P06 = Types 03, 06, 16; ENG P07-P10 = 01, 03, 05, 06, 15, 16; ENG P36-P55 & P80-84 = 01, 02, 03
3	BACnet engineering units shown with an Asterisk (*) will be assigned a BACnet engineering unit type of 95 - No Units.
4	Status codes: Special display characters such as () [] { } / \ % < > are not compatible with eLink N2 formats. Substitute text strings "-", PCT, GTN will be used. String lengths are limited to 60 total characters, including spaces.
5	
6	
7	
8	
9	
10	

Code Value	Operational Code	Code Value	Fault/Inhibit Code
0	No Abnormal Condition	0	No Fault Code
1	Unit Switch Off	1	
2	System Switch Off	2	Low Ambient Temperature
3	Lockout	3	
4	Unit Fault	4	Low Leaving Chilled Liquid Temp
5	System Fault	5	High Discharge Pressure
6	Remote Shutdown	6	
7	Daily Schedule Shutdown	7	Low Suction Pressure
8	No Run Permissive	8	
9	No Cool Load	9	
10	Anti-Coincidence Timer Active	10	
11	Anti-Recycle Timer Active	11	
12	Manual Override	12	
13	Suction Limiting	13	
14	Discharge Limiting	14	
15		15	
16	Load Limiting	16	
17	Compressor(s) Running	17	
18	Heatpump Load Limiting	18	MP/HPCO Fault
19	Pumping Down	19	Low Evaporator Temperature
20		20	
21		21	
22		22	Unit Motor Current
23		23	Low Superheat
24		24	Sensor Fault
25		25	Discharge Inhibit
26		26	MP/HPCO Inhibit
27		27	Pump Trip
28		28	Pump Fail Make Flow
29		29	High Ambient Temperature
30		30	Anti-Vacuum Low Pressure Cutout
31		31	Flow Switch Open
32		32	Leaving Chilled Liquid Temperature Sensor Fault
33		33	
34		34	
35		35	
36		36	
37		37	
38		38	
39		39	
40		40	
41		41	
42		42	
43		43	
44		44	
45		45	
46		46	
47		47	
48		48	
49		49	
50		50	



Air Cooled Scroll Liquid Chiller -YORK YLAA R410A 50Hz & 60Hz

1. GENERAL

1.01. GENERAL REQUIREMENTS

The requirements of this Section shall conform to the general provisions of the Contract, including General and Supplementary Conditions, Conditions of the Contract, and Contract Drawings.

1.02. SCOPE

Provide Microprocessor controlled, multiple scroll compressor, air-cooled, liquid chillers of the scheduled capacities as shown and indicated on the Drawings, including but not limited to:

1. Chiller package
2. Charge of refrigerant and oil
3. Electrical power and control connections
4. Chilled liquid connections
5. Manufacturer start-up

1.03. QUALITY ASSURANCE

A. Products shall be Designed, Tested, Rated and Certified in accordance with, and Installed in compliance with applicable sections of the following Standards and Codes:

1. AHRI 550/590 – Water Chilling Packages Using the Vapor Compression Cycle
2. AHRI 370 – Sound Rating of Large Outdoor Refrigerating and Air-Conditioning Equipment
3. ANSI/ASHRAE 15 – Safety Code for Mechanical Refrigeration
4. ANSI/ASHRAE 34 – Number Designation and Safety Classification of Refrigerants
5. ASHRAE 90.1 – Energy Standard for Buildings Except Low-Rise Residential Buildings
6. ANSI/NFPA 70 – National Electrical Code (N.E.C.)
7. ASME Boiler and Pressure Vessel Code, Section VIII, Division 1
8. OSHA – Occupational Safety and Health Act
9. Manufactured in facility registered to ISO 9001
10. Conform to Intertek Testing Services for construction of chillers and provide ETL/cETL Listed Mark

B. Factory Run Test: Chiller shall be pressure-tested, evacuated and fully charged with refrigerant and oil, and shall be factory operational run tested with water flowing through the vessel.

C. Chiller manufacturer shall have a factory trained and supported service organization.

D. Warranty: Manufacturer shall Warrant all equipment and material of its manufacture against defects in workmanship and material for a period of eighteen (18) months from date of shipment or twelve (12) months from date of start-up, whichever occurs first.

1.04. DELIVERY AND HANDLING

A. Unit shall be delivered to job site fully assembled with all interconnecting refrigerant piping and internal wiring ready for field installation and charged with refrigerant and oil by the Manufacturer.

B. Provide protective covering over vulnerable components for unit protection during shipment. Fit nozzles and open ends with plastic enclosures.

C. Unit shall be stored and handled per Manufacturer's instructions.



2. PRODUCTS

2.01. CHILLER MATERIALS AND COMPONENTS

A. General: Install and commission, as shown on the schedules and plans, factory assembled, charged, and tested air cooled scroll compressor chiller(s) as specified herein. Chiller shall be designed, selected, and constructed using a refrigerant with Flammability rating of "1", as defined by ANSI/ASHRAE STANDARD 34 Number Designation and Safety Classification of Refrigerants. Chiller shall include not less than two refrigerant circuits above 50 tons (200kW), scroll compressors, direct-expansion type evaporator, air-cooled condenser, refrigerant, lubrication system, interconnecting wiring, safety and operating controls including capacity controller, control center, motor starting components and special features as specified herein or required for safe, automatic operation.

B. Cabinet: External structural members shall be constructed of heavy gauge, galvanized steel coated with baked on powder paint which, when subject to ASTM B117, 1000 hour, 5% salt spray test, yields minimum ASTM 1654 rating of "6".

C. Operating Characteristics: Provide low and high ambient temperature control options as required to ensure unit is capable of operation from 30°F to 115°F (-1°C to 46°C) ambient temperature. [Optional: -10°F to 125°F (-23°C to 52°C) ambient.]

D. Service Isolation valves: Discharge (ball type) isolation valves factory installed per refrigerant circuit. Includes a system high-pressure relief valve in compliance with ASHRAE15.

E. Pressure Transducers and Readout Capability

1. Discharge Pressure Transducers: Permits unit to sense and display discharge pressure.
2. Suction Pressure Transducers: Permits unit to sense and display suction pressure.
3. High Ambient Control: Allows units to operate when the ambient temperature is above 115°F (46°C). Includes discharge pressure transducers

2.02. COMPRESSORS

A. Compressors: Shall be hermetic, scroll-type, including:

1. Compliant design for axial and radial sealing.
2. Refrigerant flow through the compressor with 100% suction cooled motor.
3. Large suction side free volume and oil sump to provide liquid handling capability.
4. Compressor crankcase heaters to provide extra liquid migration protection.
5. Annular discharge check valve and reverse vent assembly to provide low-pressure drop, silent shutdown and reverse rotation protection.
6. Initial oil charge.
7. Oil level sight glass.
8. Vibration isolator mounts for compressors.
9. Brazed-type connections for fully hermetic refrigerant circuits.
10. Compressor Motor overloads capable of monitoring compressor motor current. Provides extra protection against compressor reverse rotation, phase-loss and phase-imbalance.

2.03. REFRIGERANT CIRCUIT COMPONENTS

Each refrigerant circuit shall include: a discharge service ball type isolation valve, high side pressure relief, liquid line shutoff valve with charging port, low side pressure relief device, filter-drier, solenoid valve, sight glass with moisture indicator, thermostatic expansion valves, and flexible, closed-cell foam insulated suction line and suction pressure transducer.

2.04. HEAT EXCHANGERS



A. Evaporator:

1. Evaporator shall be brazed-plate stainless steel construction capable of refrigerant working pressure of 650 psig (3103 kPa) and liquid side pressure of 150 psig (1034 kPa) [Option for 300 psig (2068 kPa) available].
2. Brazed plate heat exchangers shall be UL listed.
3. Exterior surfaces shall be covered with 3.4" (19mm), flexible, closed cell insulation, thermal conductivity of 0.26k ([BTU/HR-Ft² - °F]/in.) maximum.
4. Water nozzles shall be provided with grooves for field provided ANSI/AWWA C-606 mechanical couplings.
5. Evaporator shall include vent and drain fittings and thermostatically controlled heaters to protect to -20°F (-29°C) ambient in off-cycle.
6. A 20-mesh, serviceable wye-strainer and mechanical couplings shall be provided for field installation on evaporator inlet prior to startup.
7. Evaporator shall be provided with piping extension kit and mechanical couplings to extend liquid connection from evaporator to edge of unit. Thermal dispersion type flow switch shall be factory installed in the evaporator outlet pipe extension and wired to the unit control panel. Insulation and heat trace on piping shall be responsibility of installing contractor. Extension kit nozzle connections shall be ANSI/AWWA C-606 (grooved).

B. Air-cooled Condenser:

1. Coils: Condenser coils shall be constructed of a single material to avoid galvanic corrosion due to dissimilar metals. Coils and headers are brazed as one piece. Integral sub cooling is included. Coils shall be designed for a design working pressure of 650 PSIG (45 bar). Condenser coil shall be washable with potable water under 100 psi (7 bar) pressure.
2. Low Sound Fans: Shall be dynamically and statically balanced, direct drive, corrosion resistant glass fiber reinforced composite blades molded into a low noise, full-airfoil cross section, providing vertical air discharge and low sound. Each fan shall be provided in an individual compartment to prevent crossflow during fan cycling. Guards of heavy gauge, PVC (poly- vinylchloride) coated or galvanized steel shall be factory installed.
3. Fan Motors: High efficiency, direct drive, 6 pole, 3 phase, insulation class "F", current protected, Totally Enclosed Air-Over (TEAO) , rigid mounted, with double sealed, permanently lubricated, ball bearings.

2.05. CONTROLS

A. General: Automatic start, stop, operating, and protection sequences across the range of scheduled conditions and transients.

B. Power/Control Enclosure: Rain and dust tight NEMA 3R powder painted steel cabinet with hinged, latched, and gasket sealed door.

C. Microprocessor Control Center:

1. Automatic control of compressor start/stop, anti-coincidence and anti-recycle timers, automatic pumpdown at system shutdown, condenser fans, evaporator pump, evaporator heater, unit alarm contacts, and chiller operation from -10°F to 125°F (-23°C to 52°C) ambient. Automatic reset to normal chiller operation after power failure.
2. Software stored in non-volatile memory, with programmed setpoints retained in lithium battery backed real-time-clock (RTC) memory for minimum 5 years.
3. Forty character liquid crystal display, descriptions in English (or Spanish, French, Italian, or German), numeric data in English (or Metric) units. Sealed keypad with sections for Setpoints, Display/Print, Entry, Unit Options & clock, and On/Off Switch.
4. Programmable Setpoints (within Manufacturer limits): display language; chilled liquid temperature setpoint and range, remote reset temperature range, daily schedule/holiday for start/stop, manual override for servicing, low and high ambient cutouts, low liquid temperature cutout, low suction pressure cutout, high discharge pressure cutout, anti-recycle timer (compressor start cycle time), and anti-coincident timer (delay compressor starts).
5. Display Data: Return and leaving liquid temperatures, low leaving liquid temperature cutout setting, low ambient temperature cutout setting, outdoor air temperature, English or metric data, suction pressure cutout



setting, each system suction pressure, liquid temperature reset via a 4-20milliamp or 0-10 VDC input, anti-recycle timer status for each compressor, anti-coincident system start timer condition, compressor run status, no cooling load condition, day, date and time, daily start/stop times, holiday status, automatic or manual system lead/lag control, lead system definition, compressor starts/operating hours (each), status of hot gas valves, evaporator heater and fan operation, run permissive status, number of compressors running, liquid solenoid valve status, load & unload timer status, water pump status.

6. System Safeties: Shall cause individual compressor systems to perform auto shut down; manual reset required after the third trip in 90 minutes. System Safeties include: high discharge pressure, low suction pressure, high pressure switch, and motor protector. Compressor motor protector shall protect against damage due to high input current or thermal overload of windings.

7. Unit Safeties: Shall be automatic reset and cause compressors to shut down if low ambient, low leaving chilled liquid temperature, under voltage, and flow switch operation.

8. Alarm Contacts: Low ambient, low leaving chilled liquid temperature, low voltage, low battery, and (per compressor circuit): high discharge pressure, and low suction pressure.

9. BAS Communications: YORKTalk 2, BACnet MS/TP, Modbus and N2 communication capabilities are standard.

D. Manufacturer shall provide any controls not listed above, necessary for automatic chiller operation. Mechanical Contractor shall provide field control wiring necessary to interface sensors to the chiller control system.

2.06. POWER CONNECTION AND DISTRIBUTION

A. Power Panels:

1. NEMA 3R/12 rain/dust tight, powder painted steel cabinets with hinged, latched, and gasket sealed outer doors. Provide main power connection(s), control power connections, compressor and fan motor start contactors, current overloads, and factory wiring.

2. Power supply shall enter unit at a single location, be 3 phase of scheduled voltage, and connect to individual terminal blocks per compressor. Separate disconnecting means and/or external branch circuit protection (by Contractor) required per applicable local or national codes.

B. Compressor, control and fan motor power wiring shall be located in an enclosed panel or routed through liquid tight conduit.

2.07. ACCESSORIES AND OPTIONS

Some accessories and options supersede standard product features. Your Johnson Controls representative will be pleased to provide assistance.

A. Microprocessor controlled, Factory installed Across-the-Line type compressor motor starters as standard.

B. Low Ambient Control: Permits unit operation to -10°F ambient. Standard unit controls to 30°F ambient.

1. High Ambient Control: Permits unit operation above 115°F ambient.

C. Power Supply Connections:

D. Control Power Transformer: Converts unit power voltage to 120-1-60 (500 VA capacity). Factory-mounting includes primary and secondary wiring between the transformer and the control panel.

E. Protective Chiller Panels (Factory or Field Mounted)

1. Louvered Panels (full unit): Painted steel as per remainder of unit cabinet, to protect condenser coils from incidental damage, visually screen internal components, and prevent unauthorized access to internal components.

F. Thermal Dispersion Flow Switch (Factory installed and wired in piping extension kit): Normally open, 30bar pressure rating, stainless steel 316L construction, IP67, -4°F to 158°F ambient rating.



G. Hot Gas By-Pass: Permits continuous, stable operation at capacities below the minimum step of unloading to as low as 5% capacity (depending on both the unit & operating conditions) by introducing an artificial load on the evaporator. Hot gas by-pass is installed on only one refrigerant circuit.

H. Vibration Isolation (Field installed):

3. EXECUTION

3.01. INSTALLATION

A. General: Rig and Install in full accordance with Manufacturer's requirements, Project drawings, and Contract documents.

B. Location: Locate chiller as indicated on drawings, including cleaning and service maintenance clearance per Manufacturer instructions. Adjust and level chiller on support structure.

C. Components: Installing Contractor shall provide and install all auxiliary devices and accessories for fully operational chiller.

D. Electrical: Coordinate electrical requirements and connections for all power feeds with Electrical Contractor (Division 16).

E. Controls: Coordinate all control requirements and connections with Controls Contractor.

F. Finish: Installing Contractor shall paint damaged and abraded factory finish with touch-up paint matching factory finish.

SECTION 3 – HANDLING AND STORAGE



WARNING

Failure to follow these instructions could result in death, serious injury or equipment damage.

Follow all warnings and instructions in the unit's Manual(s).

<table border="0"> <tr><td style="border: 1px solid black; padding: 2px;">EN</td><td>Installation Instructions for the technician / fitter</td></tr> <tr><td style="border: 1px solid black; padding: 2px;">PL</td><td>Instrukcja instalacji dla technika / monter</td></tr> <tr><td style="border: 1px solid black; padding: 2px;">SV</td><td>Installationsguide för installatör / montör</td></tr> <tr><td style="border: 1px solid black; padding: 2px;">CS</td><td>Pokyny k instalaci pro techniky a montéry</td></tr> </table>	EN	Installation Instructions for the technician / fitter	PL	Instrukcja instalacji dla technika / monter	SV	Installationsguide för installatör / montör	CS	Pokyny k instalaci pro techniky a montéry	<table border="0"> <tr><td style="border: 1px solid black; padding: 2px;">IT</td><td>Istruzioni d'installazione per il personale specializzato</td></tr> <tr><td style="border: 1px solid black; padding: 2px;">NL</td><td>Installatiehandleiding voor de vakman / monteur</td></tr> <tr><td style="border: 1px solid black; padding: 2px;">DE</td><td>Installationsanleitung für die Fachkraft / Monteur</td></tr> <tr><td style="border: 1px solid black; padding: 2px;">ES</td><td>Instrucciones de instalación para el técnico / contratista especializado</td></tr> </table>	IT	Istruzioni d'installazione per il personale specializzato	NL	Installatiehandleiding voor de vakman / monteur	DE	Installationsanleitung für die Fachkraft / Monteur	ES	Instrucciones de instalación para el técnico / contratista especializado	<table border="0"> <tr><td style="border: 1px solid black; padding: 2px;">JA</td><td>一般仕様・取扱説明書</td></tr> <tr><td style="border: 1px solid black; padding: 2px;">FR</td><td>Manuel d'installation pour le spécialiste / monteur</td></tr> <tr><td style="border: 1px solid black; padding: 2px;">RU</td><td>Инструкция по установке для техника/монтажника</td></tr> <tr><td style="border: 1px solid black; padding: 2px;">ZH</td><td>适用于技术人员与安装人员的 安装说明书</td></tr> </table>	JA	一般仕様・取扱説明書	FR	Manuel d'installation pour le spécialiste / monteur	RU	Инструкция по установке для техника/монтажника	ZH	适用于技术人员与安装人员的 安装说明书
EN	Installation Instructions for the technician / fitter																									
PL	Instrukcja instalacji dla technika / monter																									
SV	Installationsguide för installatör / montör																									
CS	Pokyny k instalaci pro techniky a montéry																									
IT	Istruzioni d'installazione per il personale specializzato																									
NL	Installatiehandleiding voor de vakman / monteur																									
DE	Installationsanleitung für die Fachkraft / Monteur																									
ES	Instrucciones de instalación para el técnico / contratista especializado																									
JA	一般仕様・取扱説明書																									
FR	Manuel d'installation pour le spécialiste / monteur																									
RU	Инструкция по установке для техника/монтажника																									
ZH	适用于技术人员与安装人员的 安装说明书																									



1. Follow all applicable regulations and safety practices during rigging and lifting.
2. Prepare and follow written rigging and lifting plan.
3. Rigging must be directed by trained professional rigger.
4. Spreader bars must be used and be long enough to prevent rigging from contacting unit.
5. Use all and only designated lift points according to units manual(s).
6. Locate center of gravity through trial lifts to account for possible variations in unit configuration.
7. Use rigging and lifting techniques that keep unit stable and level.
8. Keep clear of unit when lifted.

035-23962-000 REV A

LD18119

FIGURE 7 - RIGGING AND LIFTING LABEL

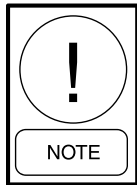

Read carefully the rigging warning label on the chiller packaging.



Rigging and lifting should only be done by a professional rigger in accordance with a written rigging and lifting plan. The most appropriate rigging and lifting method will depend on job specific factors, such as the rigging equipment available and site needs. Therefore a professional rigger must determine the rigging and lifting method to be used and it is beyond the scope of the manual to specify rigging and lifting details.

DELIVERY AND STORAGE

To ensure consistent quality and maximum reliability, all units are tested and inspected before leaving the factory. Units are shipped completely assembled and containing refrigerant under pressure. Units are shipped without export crating unless crating has been specified on the Sales Order.

If the unit is to be put into storage, before installation, the following precautions should be observed:

- The chiller must be “blocked” so that the base is not permitted to sag or bow.
- Ensure that all openings, such as water connections, are securely capped.
- Do not store where exposed to ambient air temperatures exceeding 112°F (44.5°C).
- The condensers should be covered to protect the fins from potential damage and corrosion, particularly where building work is in progress.
- The unit should be stored in a location where there is minimal activity in order to limit the risk of accidental physical damage.
- To prevent inadvertent operation of the pressure relief devices the unit must not be steam cleaned.
- It is recommended that the unit is periodically inspected during storage.

INSPECTION

Remove any transit packing and inspect the unit to ensure that all components have been delivered and that no damage has occurred during transit. If any damage is evident, it should be noted on the carrier’s freight bill and a claim entered in accordance with the instructions given on the advice note.

Major damage must be reported immediately to your local Johnson Controls representative.

MOVING THE CHILLER

Before moving the unit, ensure that the installation site is suitable for installing the unit and is easily capable of supporting the weight of the unit and all associated services.



The unit must only be lifted by the base frame at the points provided. Never move the unit on rollers, or lift the unit using a forklift truck.

Care should be taken to avoid damaging the condenser cooling fins when moving the unit.

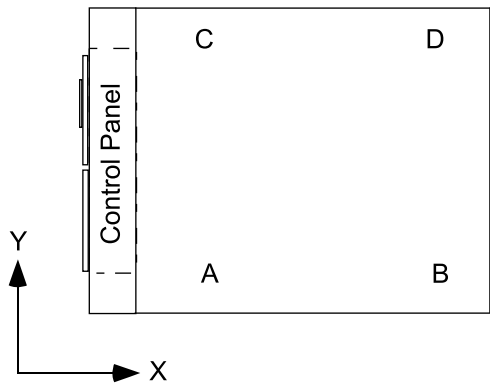

LD18120

4 - 6 Fan Units

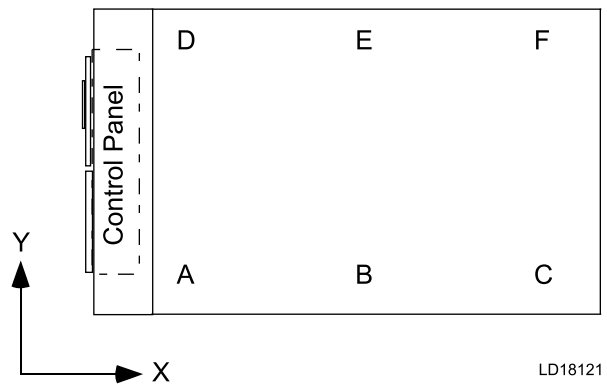

LD18121

8 Fan Units

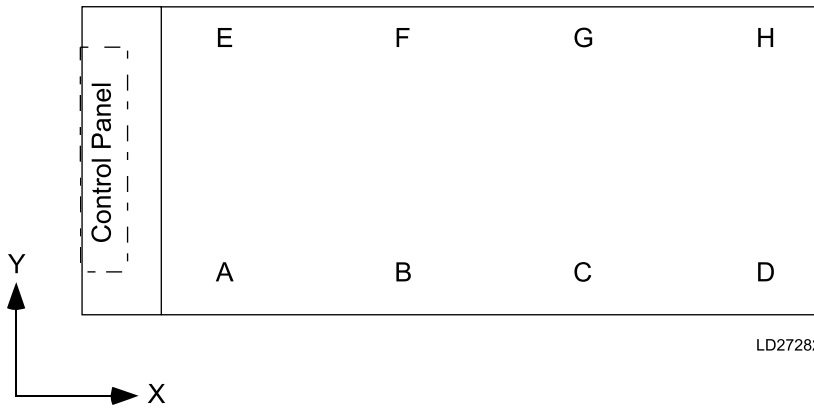

LD27282

10 Fan Units

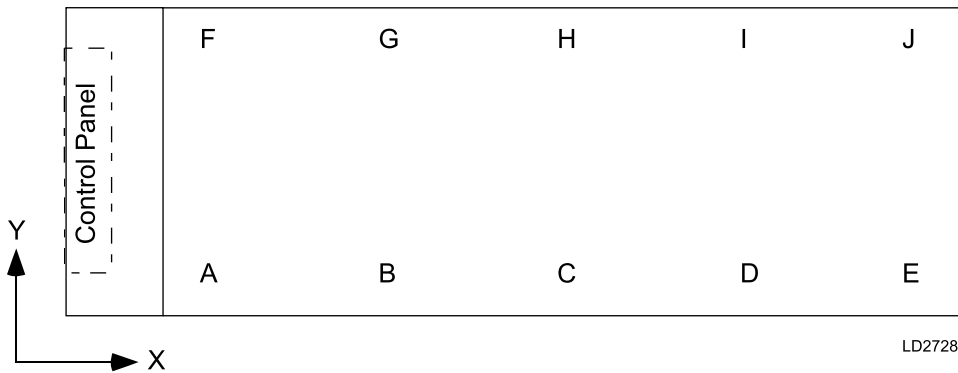

LD27283

12 Fan Units

FIGURE 8 - UNIT RIGGING/LIFTING

LIFTING WEIGHTS

See the unit nameplate for unit shipping weight. Note that weight may vary depending on unit configuration at the time of lifting. See page 54 for further information regarding shipping and operating weights.

LIFTING USING LUGS

Units are provided with lifting holes in the base frame which accept the accessory lifting lug set as shown in the figure below. The lugs (RH and LH) should be inserted into the respective holes in the base frame and turned so that the spring loaded pin engages into the hole and the flanges on the lug lock behind the hole. The lugs should be attached to the cables/chains using shackles or safety hooks.

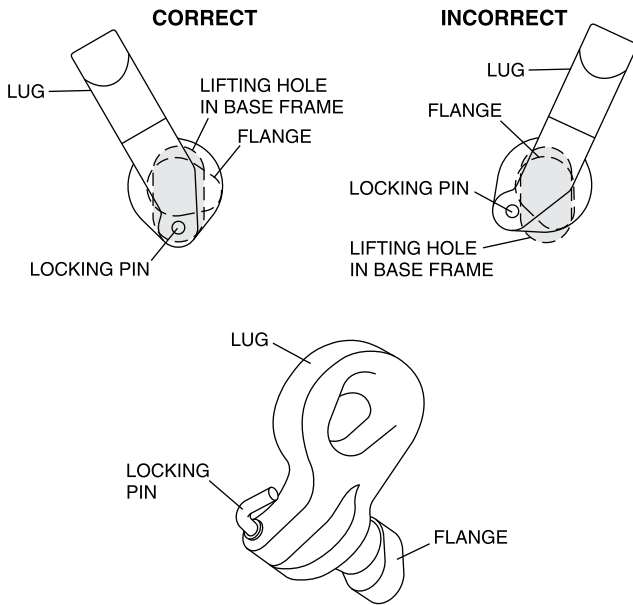

LIFTING USING SHACKLES

The shackles should be inserted into the respective holes in the base frame and secured from the inside.

Use spreader bars to avoid lifting chains hitting the chiller. Various methods of spreader bar arrangements may be used, keeping in mind the intent is to keep the unit stable and to keep the chains from hitting the chiller and causing damage.

Lifting Instructions are placed on a label on the chiller and on the shipping bag.



STANDARD LIMITED WARRANTY ENGINEERED SYSTEMS EQUIPMENT

SERVICE POLICY

Supersedes: 50.05-NM2 (812)

Form 50.05-NM2 (1212)

POLICY STATEMENT

Johnson Controls (JCI) warrants all equipment and associated factory supplied materials or start-up services performed by Johnson Controls in connection therewith, against defects in workmanship and material for a period of eighteen (18) months from date of shipment, or twelve (12) months from date of start up, whichever occurs first. Subject to the exclusions listed below, Johnson Controls, at its option, will repair or replace, FOB point of shipment, such products or components as it finds defective.

Except for reciprocating replacement compressors, which Johnson Controls warrants for a period of twelve (12) months from date of shipment, Johnson Controls warrants Johnson Controls reconditioned or replacement materials, or installation or start-up services performed by Johnson Controls in connection therewith, against defects in workmanship and material for a period of (90) days from date of shipment.

The above represents the minimum warranty policy Johnson Controls will extend to customers. Additional product specific coverage is provided as outlined in related warranty policies. No warranty repairs or replacements will be made until payment for all equipment, materials, or components has been received by Johnson Controls.

EXCLUSIONS:

Unless specifically agreed to in the contract documents, this warranty does not include the following costs and expenses:

1. Labor to remove or reinstall any equipment, materials or components.
2. Shipping, handling or transportation charges, including cranes, safety walks or other safety requirements specific to jobsites.
3. Cost of refrigerant.
4. Freight damage.
5. Field applied coatings added to any surface or heat exchanger.
6. Rental Chillers.

ALL WARRANTIES ARE VOID IF:

1. Equipment is used with refrigerants, oil, additives, or antifreeze agents other than those authorized by supplying factory.
2. Equipment is used with any material or any equipment such as evaporators, tubing, other low side equipment or refrigerant controls not approved by supplying factory.
3. Equipment has been damaged by freezing because it was not properly protected during cold weather or damaged by fire or any other conditions not ordinarily encountered.
4. Equipment is not installed, operated, maintained and serviced in accordance with instructions issued by Johnson Controls.
5. Equipment is damaged due to dirt, air, moisture, or other foreign matter entering the refrigerant system.
6. Equipment is not properly stored, protected, or inspected by the customer during the period from date of shipment to date of initial start-up.
7. Field coating of coil has occurred.
8. Equipment is damaged due to acts of god, abuse, including shipping damage, neglect, sabotage, or acts of terrorists.
9. Equipment has modifications carried out that have an effect on the original design of the product without such work being authorized by the factory. Any on site design changes or unit modification/replacement shall be authorized in advance by the factory.

THIS WARRANTY IS IN LIEU OF ALL OTHER WARRANTIES AND LIABILITIES, EXPRESS OR IMPLIED IN LAW OR IN FACT, INCLUDING THE WARRANTIES OF MERCHANTABILITY AND FITNESS FOR A PARTICULAR PURPOSE. THE WARRANTIES CONTAINED HEREIN SET FORTH BUYER'S SOLE AND EXCLUSIVE REMEDY IN THE EVENT OF A DEFECT IN WORKMANSHIP OR MATERIALS. IN NO EVENT SHALL JOHNSON CONTROLS' LIABILITY FOR DIRECT OR COMPENSATORY DAMAGES EXCEED THE PAYMENTS RECEIVED BY JOHNSON CONTROLS FROM BUYER FOR THE MATERIAL OR EQUIPMENT INVOLVED, NOR SHALL JOHNSON CONTROLS BE LIABLE FOR ANY SPECIAL, INCIDENTAL, OR CONSEQUENTIAL DAMAGES. THESE LIMITATIONS ON LIABILITY AND DAMAGES SHALL APPLY UNDER ALL THEORIES OF LIABILITY OR CAUSES OF ACTION, INCLUDING BUT NOT LIMITED TO, CONTRACT, WARRANTY, TORT, (INCLUDING NEGLIGENCE) OR STRICT LIABILITY. THE ABOVE LIMITATIONS SHALL INURE TO THE BENEFIT OF JOHNSON CONTROLS SUPPLIERS AND SUBCONTRACTORS.



	MCHX COIL CORROSION WARRANTY	
SERVICE POLICY	New Release	Form 50.05-NM6 (1016)

POLICY STATEMENT

Johnson Controls, Inc. (JCI) warrants all new Microchannel Heat Exchangers (MCHX), when installed with factory applied Environment Guard Basic or Environment Guard Premium coil protection option, against failures due to corrosion or workmanship for a period of sixty-six (66) months from date of shipment. The coil protection option must be selected and maintained in accordance with recommendations of the "MICROCHANNEL HEAT EXCHANGER TECHNOLOGY" Application Data document form 150.12-AD1, including maintaining record of quarterly inspection and cleaning. This warranty does not extend to products used for rental chiller duty. Subject to the exclusions listed below, JCI, at its option, will repair or replace, FOB point of shipment, such JCI products or components as it finds defective.

EXCLUSIONS:

Unless specifically agreed to in the contract documents, this warranty does not include the following costs and expenses:

1. Labor to remove or reinstall any equipment, materials or components.
2. Shipping, handling or transportation charges.
3. Cost of refrigerant.
4. Cost of rental chillers or other temporary cooling equipment.

No warranty repairs or replacements will be made until payment for all equipment, materials, or components has

been received by JCI.

ALL WARRANTIES ARE VOID IF:

1. Equipment is used with refrigerants, oil, or antifreeze agents other than those authorized by JCI.
2. Equipment is used with any material or any equipment such as evaporators, tubing, other low side equipment, or refrigerant controls not approved by JCI.
3. Equipment has been damaged by freezing because it is not properly protected during cold weather, or damaged by fire or any other conditions "not" ordinarily encountered.
4. Equipment is not installed, operated, maintained and serviced in accordance with instructions issued by JCI.
5. Equipment is damaged due to dirt, air, moisture, or other foreign matter entering the refrigerant system.
6. Equipment is not properly stored, protected, or inspected by the customer during the period from date of shipment to date of initial start-up.
7. Equipment is damaged due to acts of God, abuse, neglect, sabotage, or acts of terrorists.

THIS WARRANTY IS IN LIEU OF ALL OTHER WARRANTIES AND LIABILITIES, EXPRESS OR IMPLIED IN LAW OR IN FACT, INCLUDING THE WARRANTIES OF MERCHANTABILITY AND FITNESS FOR A PARTICULAR PURPOSE. THE WARRANTIES CONTAINED HEREIN SET FORTH BUYER'S SOLE AND EXCLUSIVE REMEDY IN THE EVENT OF A DEFECT IN WORKMANSHIP OR MATERIALS. IN NO EVENT SHALL JOHNSON CONTROLS' LIABILITY FOR DIRECT OR COMPENSATORY DAMAGES EXCEED THE PAYMENTS RECEIVED BY JOHNSON CONTROLS FROM BUYER FOR THE MATERIAL OR EQUIPMENT INVOLVED, NOR SHALL JOHNSON CONTROLS BE LIABLE FOR ANY SPECIAL, INCIDENTAL, OR CONSEQUENTIAL DAMAGES. THESE LIMITATIONS ON LIABILITY AND DAMAGES SHALL APPLY UNDER ALL THEORIES OF LIABILITY OR CAUSES OF ACTION, INCLUDING BUT NOT LIMITED TO, CONTRACT, WARRANTY, TORT, (INCLUDING NEGLIGENCE) OR STRICT LIABILITY. THE ABOVE LIMITATIONS SHALL INURE TO THE BENEFIT OF JOHNSON CONTROLS SUPPLIERS AND SUBCONTRACTORS.



CERTIFICATE OF LIMITED WARRANTY

JOHNSON CONTROLS EQUIPMENT

Contract Number:
Ship Date:

Model Number: YLAA0200HE
Start Date:

Serial Number:

POLICY STATEMENT

Johnson Controls (JCI) warrants all equipment and associated factory supplied materials or start-up services performed by Johnson Controls in connection therewith, against defects in workmanship and material. **The warranty period begins at start up, or six (6) months from the ship date, whichever occurs first.** Subject to the exclusions listed below, Johnson Controls, at its option, will repair or replace, FOB point of shipment, such products or components as it finds defective.

Except for reciprocating replacement compressors, which Johnson Controls warrants for a period of twelve (12) months from date of shipment, Johnson Controls warrants Johnson Controls reconditioned or replacement materials, or installation or start-up services performed by Johnson Controls in connection therewith, against defects in workmanship and material for a period of (90) days from date of shipment.

The above represents the minimum warranty policy Johnson Controls will extend to customers. Additional product specific coverage is provided as outlined herein or in separate related warranty policies. No warranty repairs or replacements will be made until payment for all equipment, materials, components, or services has been received by Johnson Controls.

Warranty Type	Warranty Duration	Expiration Date
Standard - Entire Unit - Labor only	1 Year	
Standard - Entire Unit - Parts only	1 Year	
Extended - Compressor - Parts and Labor	5 Years	
Extended - Refrigerant	1 Year	

Alongside this limited warranty, for all new York™ air or water-cooled chillers and/or Metasys™ building automation systems installed in the US and Canada and sold through Seller owned and operated branches, Seller also provides a Year One Service Agreement for such equipment, the scope, limitations, terms and conditions of which are at <https://www.johnsoncontrols.com/yearoneservice> (collectively, "Year One Service"). Seller will not provide a credit against purchase price if offered Year One Service is declined.

EXCLUSIONS:

Unless specifically agreed to in the contract documents, or associated with additional warranty options listed above, this warranty does not include the following costs and expenses:

1. Labor to repair, remove, or reinstall any equipment, materials or components.
2. Special shipping, handling or transportation charges, including cranes, safety walks or other safety requirements specific to jobsites.
3. Cost of refrigerant.
4. Freight damage.
5. Field applied coatings added to any surface or heat exchanger.
6. Rental chillers.
7. Normal wear and tear or corrosion.

ALL WARRANTIES ARE VOID IF:

1. Equipment is used with refrigerants, oil, additives, or antifreeze agents other than those authorized by supplying factory.
2. Equipment is used with any material or any equipment such as evaporators, tubing, other low side equipment or refrigerant controls not approved by supplying factory.

3. Equipment has been damaged by freezing because it was not properly protected during cold weather or damaged by fire or any other conditions not ordinarily encountered.
4. Equipment is not applied, installed, operated, maintained and serviced in accordance with instructions issued by Johnson Controls.
5. Equipment is damaged due to dirt, air, moisture, or other foreign matter entering the refrigerant system.
6. Equipment is not properly stored, protected, or inspected by customer during the period from date of shipment to date of initial start-up.
7. Field coating of coil has occurred.
8. Equipment is damaged due to acts of God, abuse, including shipping damage, neglect, sabotage, or acts of terrorists.
9. Equipment has modifications carried out that have an effect on the original design of the product without such work being authorized by the factory. Any on site design changes or unit modification/replacement shall be authorized in advance by the factory.
10. Equipment is moved from the location where it is originally placed in service, unless performed by certified Johnson Controls employees who have followed Johnson Controls' then-current installation and operations procedures as evidenced by signed start-up documentation.

THIS WARRANTY IS IN LIEU OF ALL OTHER WARRANTIES AND LIABILITIES, EXPRESS OR IMPLIED IN LAW OR IN FACT, INCLUDING THE WARRANTIES OF MERCHANTABILITY AND FITNESS FOR A PARTICULAR PURPOSE. THE WARRANTIES CONTAINED HEREIN SET FORTH BUYER' S SOLE AND EXCLUSIVE REMEDY IN THE EVENT OF A DEFECT IN WORKMANSHIP OR MATERIALS. IN NO EVENT SHALL JOHNSON CONTROLS' LIABILITY FOR DIRECT OR COMPENSATORY DAMAGES EXCEED THE PAYMENTS RECEIVED BY JOHNSON CONTROLS FROM BUYER FOR THE MATERIAL OR EQUIPMENT INVOLVED, NOR SHALL JOHNSON CONTROLS BE LIABLE FOR ANY SPECIAL, INCIDENTAL, OR CONSEQUENTIAL DAMAGES. THESE LIMITATIONS ON LIABILITY AND DAMAGES SHALL APPLY UNDER ALL THEORIES OF LIABILITY OR CAUSES OF ACTION, INCLUDING BUT NOT LIMITED TO, CONTRACT, WARRANTY, TORT, (INCLUDING NEGLIGENCE) OR STRICT LIABILITY. THE ABOVE LIMITATIONS SHALL INURE TO THE BENEFIT OF JOHNSON CONTROLS SUPPLIERS AND SUBCONTRACTORS.

Products furnished, but not manufactured, by Johnson Controls are not covered by this warranty. This Warranty does not apply to: i) any equipment, materials or products manufactured according to Buyer's specifications; (ii) consumable equipment, materials or products; (iii) equipment, materials or products purchased through other than JCI or a JCI authorized channel; and (iv) any software (such software being warranted under the applicable User Terms or, if none, the terms of the general end user license agreement found at <http://www.johnsoncontrols.com/techterms>). Products furnished but not manufactured by Johnson Controls may be covered by the manufacturer of such products and Buyer's sole and exclusive remedy for such products is limited to any warranty given by said manufacturer.

To qualify for warranty consideration under this Johnson Controls warranty, Buyer must immediately notify Johnson Controls at the earlier of the Buyer's discovery of the defect or the time at which the Buyer should have discovered the defect with the exercise of due diligence. Buyer must also promptly thereafter return to Johnson Controls (freight pre-paid by Buyer) all defective parts. Nothing herein is intended to provide warranty coverage to lessees or anyone other than Buyer and no third-parties are intended to be beneficiaries of this Limited Warranty.

LIMITED REFRIGERANT WARRANTY

Johnson Controls (JCI) warrants to the customer named herein, that JCI will provide the customer free of charge, with replacement refrigerant in the case of any refrigerant loss due to system leaks as a result of a manufacturing defect. Services to recycle contaminated refrigerant are also included in the event of system contamination resulting from a manufacturing defect. This warranty is offered within the extended warranty period and exclusions stated above and is only available in combination with entire unit parts and labor warranty. This Limited Refrigerant warranty is offered as an extension to the standard limited warranty and is subject to the same limitations and exclusions stated therein, which are hereby incorporated herein by reference. Remote evaporator, remote condenser, finned tube, and mobile units are excluded from this coverage.

COMPRESSOR PARTS AND LABOR WARRANTY

Johnson Controls warrants to Customer parts and labor for compressor only. Coverage does not include any other components associated with the named equipment. This warranty is offered as an extension to the standard limited warranty and is subject to the same limitations and exclusions stated therein.

If you are interested in adding additional coverage, contact your local JCI branch for more information about extended warranty.

Customer Signature: _____

Johnson Controls Representative: _____

Date: _____

Equipment Release Approval Form

The following table must be completed prior to releasing the equipment for fabrication. Please initial the column indicating the information contained in this submittal has been verified, or indicate to refer to a marked-up page.

SUBMITTAL VERIFICATION	
	Purchaser Initials
Unit quantities and tag designations are correct.	
Equipment dimensions (length, width, and height) and weights have been verified to comply with jobsite conditions and rigging requirements.	
Electrical voltage and electrical connections are compatible with jobsite requirements.	
Unit handling/orientation is suitable for installation based on mechanical system and jobsite spatial constraints. This includes (but is not limited to) unit piping/ductwork connections and enclosure/access door locations.	

Important Notes:

- 1) Actual fabrication release cannot commence until this form is signed by the customer and returned to JCI along with a release notification with date and ship to address.
- 2) Equipment "lead-time" does not start until confirmed release documentation is received, and the order is actually released to the factory.
- 3) Modifications to equipment configurations after fabrication release may impact cost and lead-time.
- 4) Attached configurations are as shown in the approved equipment submittals or as defined in superseding customer correspondence.

6) Note that once this document is confirmed, the equipment configurations defined by this document take precedence over all other documents.

7) "Want date" and/or "ship to address" changes made after this document is confirmed may impact cost and lead-time.

Please fill out the following table and refer to the receiving/rigging instructions in this submittal to help ensure a smooth delivery and installation of the equipment.

DELIVERY INFORMATION	
	Please fill out information below
Contact name for coordinating delivery of equipment with transportation company:	
Contact phone number:	
Advance notice required from transportation company prior to delivering equipment (typically 48 hours):	
Ship to address:	
Other special shipping instructions or requirements:	

CUSTOMER APPROVAL:

Customer Name: _____

Signature (*) _____

Date: _____