

THE ROBERTS GROUP, PSC
239-C Southland Drive
LEXINGTON, KY 40503
859-276-2006

Review is for conformance with information given and the design concept expressed in the contract documents. No review is made of detailed dimensions or quantities. Conformance with the contract documents remain the contractor's responsibility.

A NO EXCEPTIONS TAKEN

B APPROVED AS NOTED

C AMEND & RESUBMIT

D REJECTED RESUBMIT SEE REMARKS

DATE: November, 13 2025

REVIEWED BY: G.D.E.

PROJECT: SHELL SHACK
LOCATION: ARLINGTON, TX
TRG#: 25031

RE: RTU SUBMITTAL (DAIKIN IS ALTERNATE TO SPECIFIED TRANE)

COMMENTS:

- 1. Contractor shall coordinate all power, conduits, wiring, and breaker sizes with electrical contractor.**
- 2. Contractor shall coordinate all gas capacities, condensate, piping, and connections with plumbing contractor.**
- 3. Contractor shall coordinate all curb locations and duct connections with structure. Contractor shall provide and install any general steel, duct transitions and/or fittings as required for connection to duct mains in ceiling below for a complete and operational system.**
- 4. Any changes required to accommodate the Daikin alternate to the specified Trane RTU-1 and RTU-2 are the responsibility of this contractor.**

END OF COMMENTS



SUBMITTAL

D4 Construction Services, LLC
PO Box 2707
Rowlett, TX 75030-2707
Office: 972-463-0390
Fax: 972-463-0328

Job No: 251011

Job Name: Shell Shack
Arlington Highlands
4000 Five Points Blvd - Suite 101
Arlington, TX 76018

Spec Section Title: HVAC Equipments

Submittal Title: Rooftop Units - (RTU1/RTU 2)

Submitted To: Civitarese Morgan Architecture
3341 Regent Blvd. Suite 130-321
Irving, TX 75063
Contact: Rick Civitarese

Spec Section No: 23 74 00

Submittal No:

Revision No: 00

Received From: NDT Heating & Air Conditioning
Inc

Contractor's Stamp

This submittal has been reviewed for general Compliance with the plans and specifications. This review and response indicated below does not relieve the subcontractor/supplier of any Contractual responsibilities including the furnishing of all items required by the documents and the confirmation of all quantities and dimensions.

Shop Drawings First Submittal
 Product Data Resubmittal
 Samples Other

Reviewed by Vishal Chouhan
 Approved by Vishal Chouhan
D4CS Date: 11/11/2025

Architect's/Engineer's Stamp

Blank area for Architect's/Engineer's Stamp.



HVAC Equipment Submittal Data

For Review and Approval

11/10/2025

Project Info

Project Name: **Shell Shack**
Software version: **3.0**

Submitted By

Dealer Name: **Bill Fenton**
Email: bill.fenton@daikincomfort.com

Certifications:

Daikin brand heating and cooling units are certified as follows:

- AHRI Certified
- ETL & CETL Listed
- GAMA Certified

Limited Warranty:

- 5 year parts limited warranty
- 20 year heat exchanger limited warranty
- Complete warranty details attached

Daikin North America, LLC is not responsible for products installed outside the United States or its territories, or Canada.

Table of Contents

Model Number	Item	Description	Page
DHG1204LH00227C	RTU	DHG1204L240FABFXXFEXXX Performance	3-6
Dimensional Drawings			
DHG1204LH00227C	DHG7.5_12.5 R32 Dimensional Data		7-7
DHG1204LH00227C	Medium Chassis 10T & 12.5T Blower Curve Direct Drive R32		8-8
Field Install Accessories			
DHG1204LH00227C	RH Room		9-10
DHG1204LH00227C	Thermistors Room		11-12
DHG1204LH00227C	Filtration-MERV8		13-14
DHG1204LH00227C	MC Low Leak Downflow Economizer For DDC Controls W/ Dry Bulb Sensor		15-16
DHG1204LH00227C	MC Hail Guard		17-17
Factory Install Accessories			
DHG1204LH00227C	Conv Outlet - Powered And Non Powered		18-21
DHG1204LH00227C	DDC-BACnet protocol		22-30
DHG1204LH00227C	Non Fused Disconnect Switch		31-34
DHG1204LH00227C	Hinged Panels		35-35
DHG1204LH00227C	HGRH		36-37
DHG1204LH00227C	Thru the base connections Small Medium Chassis		38-41
	Limited Warranty		42-44

Design Requirements		Model Number: DHG1204LH00227C
Cooling Capacity	120,000 BTU/h	Code String: DHG1204L240FABFXXFEXXX
Configuration	Downflow	Tag: RTU
<ul style="list-style-type: none"> - R-32 chlorine-free refrigerant - High-efficiency Copeland scroll compressor(s) - Copper tube / aluminum fin coils - High-capacity, steel-cased filter dryer - High- and Low-pressure switches - Lugged electrical contactor - Single-point power - Color Coded Wiring - Foil Faced Internal Insulation - Heavy-gauge, galvanized-steel cabinet - UV-resistant powder-paint finish - Full perimeter base rail 		Cooling Performance *4 Total Capacity 111,378 BTU/h Sensible Capacity 81,177 BTU/h Cooling Stages Two Refrig Type R-32 Compressor Type Copeland Scroll Pressure Switches High & Low Pressure (std) Outdoor Design Temp 105.00°F Entering Air Temp(db) 80.00°F Entering Air Temp(wb) 67.00°F Leaving Air Temp(db) 61.10°F Leaving Air Temp(wb) 58.00°F Efficiency 17 IEER/12.5 EER
Unit Electrical Data		Heating Performance *4
Power Supply	460/3/60 VOLT/PH	Heat Type Gas
Total Unit MCA	26.2 A	High Stage Input / Output 240.00/194.40 (MBH)
Total Unit MOP	30.0 A	Low Stage Input / Output 180.00/145.80 (MBH)
Indoor Motor HP	3.5 HP	Entering Air Temp 55.00 °F
Total Unit FLA	24.30 A	Leaving Air Temp 100.40 °F
• Compressor RLA	15.4	Heat Exchanger Standard Aluminized
• Blower FLA	7.2	Supply Air Blower Performance
• Outdoor Fan FLA	1.7	ACFM 4000 cfm
SCCR	5 kA	SCFM 3917 cfm
		ESP 1.00 IWG
		Hot Gas Reheat 0.15 IWG
		Filtration-MERV8 0.03 IWG
		Total ESP 1.18 IWG
		Blower Type Direct Drive - Medium Static
		Elevation 400 ft
		Physical Attributes
		Base Unit Oper. Weight (lbs) 1296
		Filter(s) 20"X25"X2" Qty: 2 25"X25"X2" Qty: 2

Outdoor sound (db) at 60 Hz									
Model	A-Weighted	63	125	250	500	1000	2000	4000	8000
120	81.3	N/A	68.2	71.6	73.7	76.0	75.8	70.5	60.7

db - decibel

Notes:

- 1 Outdoor sound data is measured in accordance with AHRI standard 270.
- 2 Measurements are expressed in terms of sound power. Do not compare these values to sound pressure values because sound pressure depends on specific environment factors which normally do not match individual applications. Sound power values are independent of the environment and therefore more accurate.
- 3 A-weighted sound ratings filter out high and very low frequencies, to better approximate the response of average human ear. A-weighted measurements for Daikin units are taken in accordance with AHRI standard 270.
- 4 All air temps are measured at the unit's inlet and outlet. Air temps are not measured at the coil.

HGRH Performance

ODDB	EATDB	EATWB	CFM	TC	SHR	SHC	LATDB	LATWB	EARH	LARH	MR
95.00	78.00	62.00	2250	38773	0.52	20238	70.05	56.22	0.40	0.41	17.28

* HGRH table is closet available data for entered leaving air temperature.

HGRH Performance Notation Reference

- ODDB - Outdoor Dry Bulb Temperature(°F)
- EATDB - Entering Air Dry Bulb Temperature(°F)
- EATWB - Entering Air Wet Bulb Temperature(°F)
- TC - Total Capacity(BTU/h)
- SHC - Sensible Heat Capacity(BTU/h)
- SHR - Sensible Heat Ratio
- LATDB - Leaving Air Dry Bulb Temperature(°F)
- LATWB - Leaving Air Wet Bulb Temperature(°F)
- EARH - Entering Air Relative Humidity(%)
- LARH - Leaving Air Relative Humidity(%)
- MR - Moisture Removal(lbs/h)

LIST OF ACCESSORIES

Model Number: DHG1204LH00227C; Code String: DHG1204L240FABFXXFEXXX; Tag: RTU;

Accessories					
Fld Inst	Fct Inst	Item #	Description	Dimensions	lbs
	Y	TTBCKHE02FI	Thru-The-Base Connections		1
Y		0270L02690MC	14" Roof Curb		N/A
Y		0130L00226	DDC Space Dry-Bulb Sensor Wall Mounted		N/A
	Y	SDSKTP2FIM01	Supply Air Smoke Detector	Fact Inst	11
	Y	HGDRMDG01FI	Hinged Panels		34
Y		DPOFSK02	Overflow Switch		N/A
	Y	CONVOUTFNPM	Non Powered GFCI Convenience Outlet	Fact Inst	2
Y		0270L02680MC	Condenser Hail Guard		N/A
Y		0130L00224	DDC Space Enthalpy Sensor Wall Mounted		N/A
	Y	DSC060B58YH02FI	Non Fused Disconnect Switch	Fact Inst	5
Y		0270L02608MC	Low-Leak Downflow Economizer For DDC Controls W/ Dry Bulb Sensor		N/A
Y		0160L00274	Filtration-MERV8		N/A
	Y		Hot Gas Reheat	1	N/A
	Y		DDC Communicating Controller	8.5 x 6.05	2
	Y		Low Ambient Control		32
			Base Unit Oper. Weight		1296
			Total Weight		1383

CORNER WEIGHTS DIMENSIONS

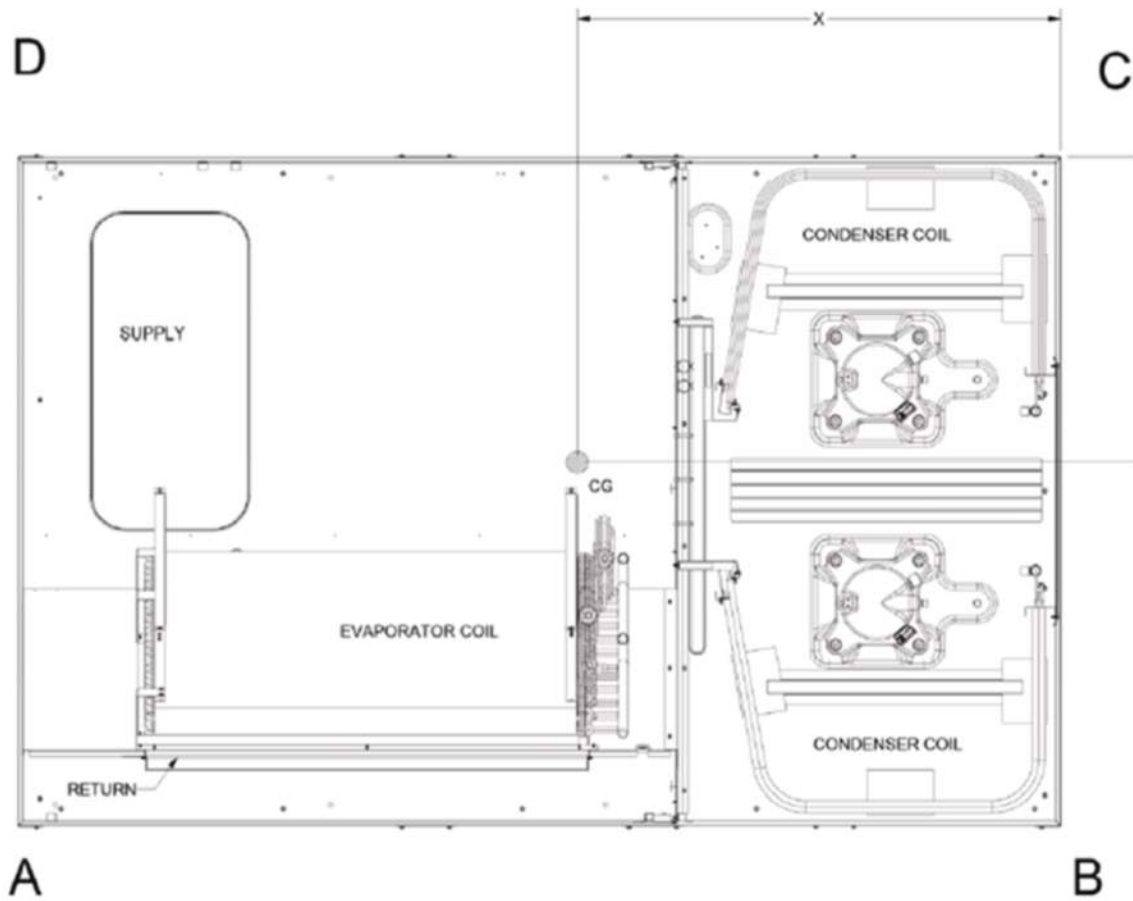

Model	Shipping Weight (lbs)	Operating Weight (lbs)	Corner Weights (lbs)				Length	Width
			A	B	C	D	X (in)	Y (in)
DHG1204LH	1353	1296	328	313	302	353	45.20	31.70

Model Size	DIM "A"
DHG090	54 ³ / ₅
DHG102	54 ³ / ₅
DHG120	54 ³ / ₅
DHG150	58 ³ / ₅

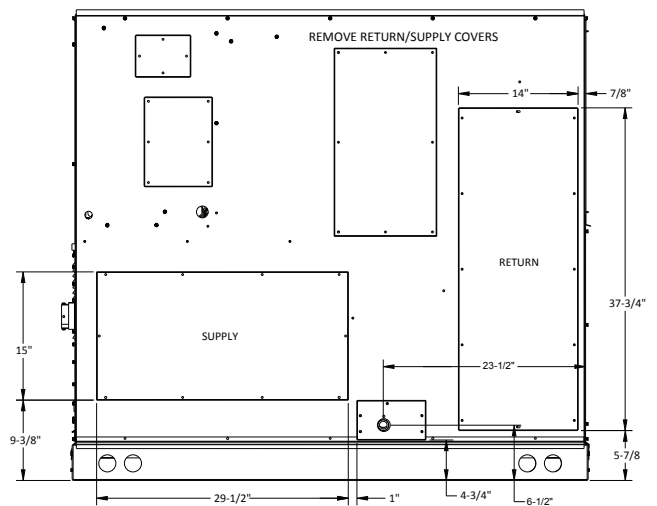
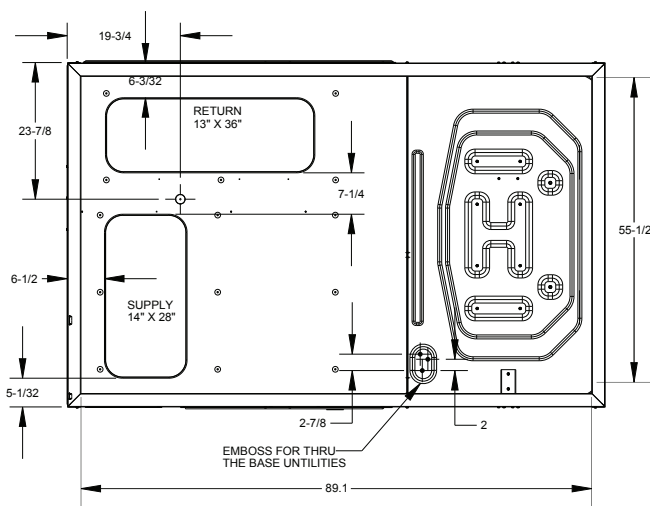
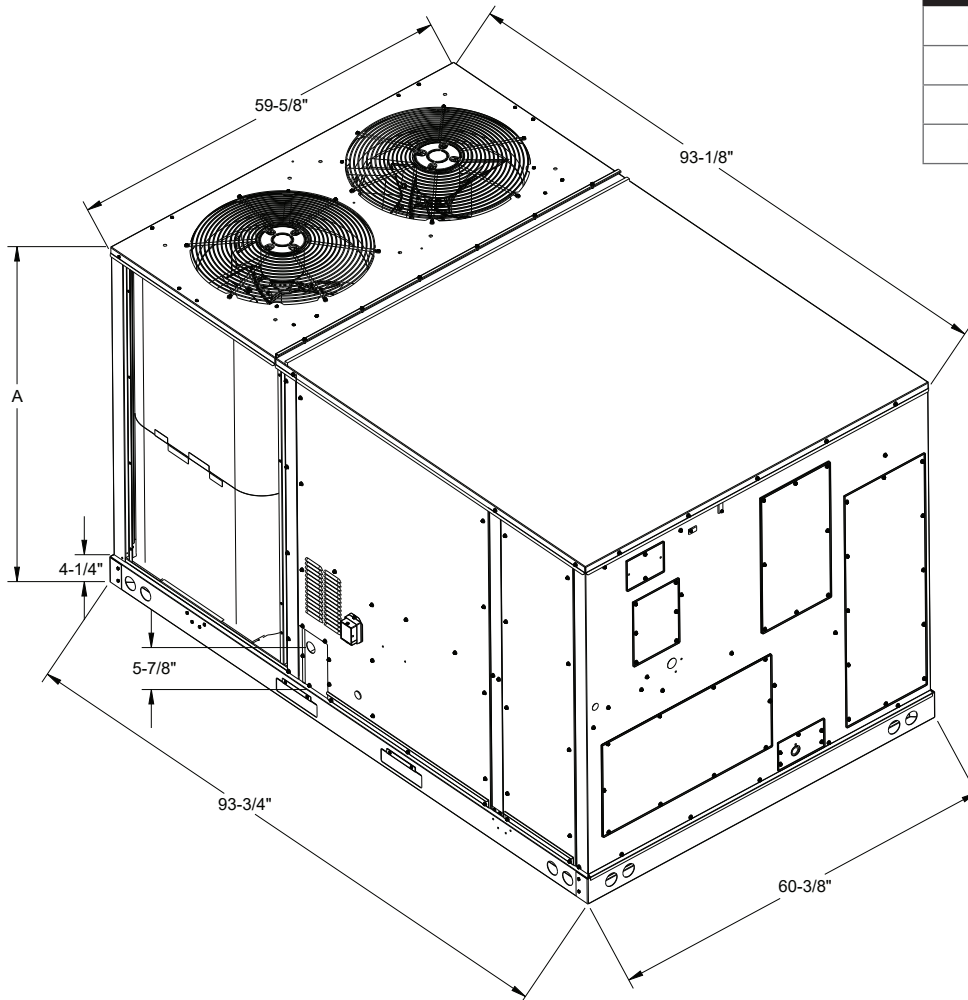

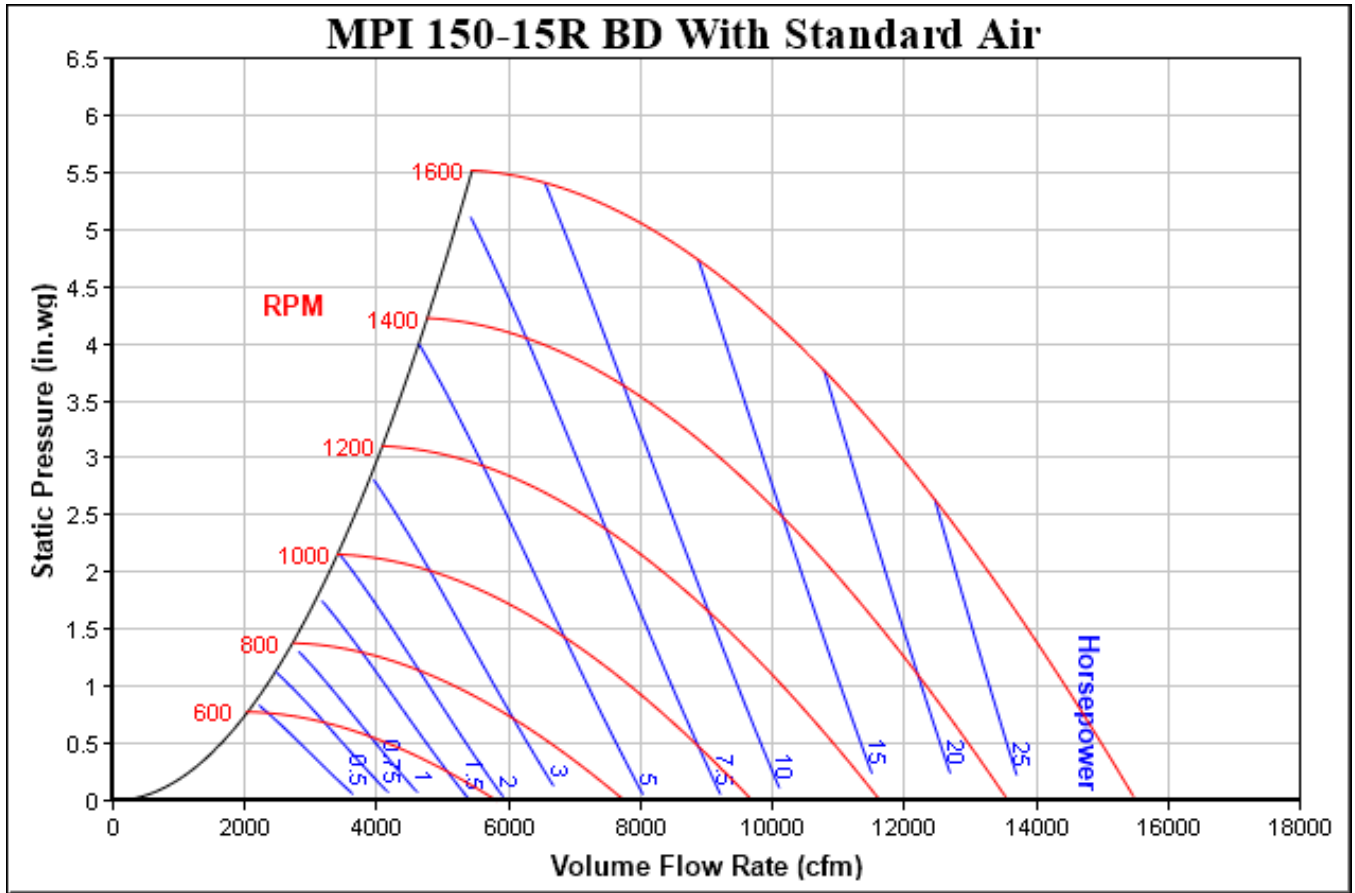



RH ROOM

Relative Humidity Room, Thermistor

The ACI Relative Humidity with Thermistor Room Series utilizes a thermoset polymer capacitive sensing element with a factory fitted hydrophobic filter to improve its moisture resistance. The sensing elements multilayer construction also provides excellent resistance in applications where dust, dirt, oils and common environmental chemicals are found. The RH room sensors include on board DIP switches which allow the user to select the desired output signal and can be powered by AC or DC power sources. Single point field calibration can be performed by using the increment and decrement calibration DIP switches to adjust your curve up or down in +/- 0.5% increments with each toggle of the corresponding switches. These enhancements provide increased flexibility and outstanding long-term reliability without the need to replace the sensors in the field. There are two enclosure options in this series which should satisfy most commercial decors. Both enclosures feature four-way airflow to minimize self-heating. Three point NIST Calibration Certificates are available.

Both enclosures feature four-way airflow to minimize self-heating. Three point NIST Calibration Certificates are available.

Applications: Humidification, Dehumidification, Monitoring Indoor Space Humidity, Clean Rooms, Hospitals, Process Control, Laboratories, Museums, Schools, Office Buildings, Data Centers, ESD (Anti-Static) Control

The ACI RH Thermistors Room is covered by ACI's Five (5) Year Limited Warranty. The warranty can be found in the front of ACI's Sensors & Transmitters catalog, as well as on ACI's website, www.workaci.com.

PRODUCT SPECIFICATIONS

RH Supply Voltage: (Reverse Polarity Protected):	4-20 mA: 250 Ohm Load: 15 - 40 VDC / 18 - 28 VAC 500 Ohm Load: 18 - 40 VDC / 18 - 28 VAC
RH Supply Current (VA):	0-5 VDC: 12 - 40 VDC / 18 - 28 VAC 0-10 VDC: 18 - 40 VDC / 18 - 28 VAC
RH Output Load Resistance:	Voltage Output: 8 mA maximum (0.32 VA) Current Output: 24 mA maximum (0.83 VA)
RH Output Signal:	4-20 mA: 700 Ohms maximum 0-5 VDC or 0-10 VDC: 4K Ohms Minimum
RH Accuracy @ 77°F (25°C):	2-wire: 4 - 20 mA (Factory Default) 3-wire: 0-5 or 0-10 VDC & 4 - 20 mA (Field Selectable)
RH Measurement Range:	+/- 1% over 20% RH Range between 20 to 90% +/- 2%, 3%, or 5% from 10 to 95%
Operating RH Range:	0-100%
Operating Temperature Range:	0 to 95% RH, non-condensing
Storage Temperature Range:	35 to 122°F (1.5 to 60°C)
RH Stability Repeatability Sensitivity:	-40 to 149°F (-40 to 65°C)
RH Response Time (T63):	Less than 2% drift / 5 years 0.5% RH 0.1% RH
RH Sensor Type:	20 Seconds Typical
RH Transmitter Stabilization Time:	Capacitive with Hydrophobic Filter
RH Connections Wire Size:	30 Minutes (Recommended time before doing accuracy verification)
RH Terminal Block Torque Rating:	Screw Terminal Blocks (Polarity Sensitive) 16 (1.31 mm ²) to 26 AWG (0.129 mm ²)
RH NIST Test Points:	4.43 to 5.31 lb-in (0.5 to 0.6 Nm)
Nominal Thermistor Resistive Output @ 77°F (25°C) (Lead Wire Colors) Non-Linear NTC (Negative Temperature Coefficient):	Default Test Points: 3 Points (20%, 50% & 80%) 1% NIST Test Points: 5 Points within selected 20% Range (ie. 30%-50% are 30, 35, 40, 45 & 50)
Thermistor Accuracy 32-158°F (0-70°C):	RHx-1.8K Series: 1.8KΩ (Red/Yellow) RHx-10KS Series: 10KΩ (White/Blue) RHx-3K Series: 3KΩ (White/Brown) RHx-10K-E1 Series: 10KΩ (Gray/Orange) RHx-AN Series (Type III): 10KΩ (White/White) RHx-20K Series: 20KΩ (Brown/Blue) RHx-AN-BC Series: 5.238KΩ (White/Yellow) RHx-50K Series: 50KΩ nominal (Brown/Yellow) RHx-CP Series (Type II): 10KΩ (White/Green) RHx-100KS Series: 100KΩ (Black/Yellow) RHx-CSI Series: 10KΩ (Green/Yellow)
Thermistor Power Dissipation Constant:	+/- 0.36°F (0.2°C) except 10K-E1 Series: +/- 0.54°F (0.3°C)
Thermistor Sensor Response Time (T63):	1.8K Series: +/- 0.9°F (0.5°C) @ 77°F (25°C) & +/- 1.8°F (1.0°C) from 32 to 158°F (0 to 70°C)
Temperature Connections Wire Size:	3 mW/°C except 1.8K Series: 1 mW/°C; 10K-E1 Series: 2 mW/°C
Temperature Terminal Block Torque Rating:	10 Seconds nominal
Enclosure Material (Color):	Screw Terminal Blocks 16 (1.31 mm ²) to 26 AWG (0.129 mm ²)
Enclosure Flammability Rating:	4.43 to 5.31 lb-in (0.5 to 0.6 Nm)
Product Dimensions (L x W x D):	"-R2" Enclosure: ABS (White) "-R" Enclosure: ABS (Beige)
Agency Approvals:	UL94-HB
	"-R2" Enclosure: 4.50" (114.3 mm) x 2.75" (69.85 mm) x 1.12" (28.45 mm) "-R" Enclosure: 4.50" (114.3 mm) x 2.75" (69.85 mm) x 1.12" (28.45 mm)
	A/RHx-xx-R2 Series: 0.17 lbs. (0.077 kg) A/RHx-xx-R Series: 0.17 lbs. (0.077 kg)



ROOM

Wall Mount Enclosures, Thermistor

The ACI Thermistor Room Series combines option flexibility with attractive styling in our “R2” or “R” style enclosures which include four-way air flow design too minimize self-heating to the sensor. These enclosures are offered in a White “R2” or Beige “R” color depending on the enclosure style. These units are designed to be mounted over a single gang junction box or hole in the wall using drywall anchors. Screw terminal blocks are available for making all connections to your building management system (network). An optional 1/8” Black foam pad with pressure sensitive adhesive is available to insulate the sensor from thermal drafts within the wall or wall surface. A 1/16” Hex driver is needed to secure the cover from being easily removed. The “LCD” option uses two temperature sensors to monitor the ambient air temperature in the space and is factory calibrated at a single point.

Applications: Space Temperature Sensing, Decorative Wall Sensor Applications, Office Buildings, Schools, Colleges, Commercial Buildings, OEM Opportunities

The ACI Thermistor Room is covered by ACI's Five (5) Year Limited Warranty. The warranty can be found in the front of ACI's Sensors & Transmitters catalog, as well as on ACI's website, www.workaci.com.

PRODUCT SPECIFICATIONS													
Sensor Type Sensor Curve:	Thermistor Non-Linear, NTC (Negative Temperature Coefficient)												
Number Temperature Sensing Points:	One												
Sensor Output @ 25°C (77°F):	<table border="0"> <tr> <td>A/1.8K Series: 1.8KΩ nominal</td> <td>A/CSI Series: 10KΩ nominal</td> </tr> <tr> <td>A/3K Series: 3KΩ nominal</td> <td>A/10KS Series: 10KΩ nominal</td> </tr> <tr> <td>A/AN Series (Type III): 10KΩ nominal</td> <td>A/10K-E1 Series: 10KΩ nominal</td> </tr> <tr> <td>A/AN-BC Series: 5.238KΩ nominal</td> <td>A/50K: 50KΩ nominal (Brown/Yellow)</td> </tr> <tr> <td>A/20K Series: 20KΩ nominal</td> <td>A/100KS Series: 100KΩ nominal</td> </tr> <tr> <td>A/CP Series (Type II): 10KΩ nominal</td> <td></td> </tr> </table>	A/1.8K Series: 1.8KΩ nominal	A/CSI Series: 10KΩ nominal	A/3K Series: 3KΩ nominal	A/10KS Series: 10KΩ nominal	A/AN Series (Type III): 10KΩ nominal	A/10K-E1 Series: 10KΩ nominal	A/AN-BC Series: 5.238KΩ nominal	A/50K: 50KΩ nominal (Brown/Yellow)	A/20K Series: 20KΩ nominal	A/100KS Series: 100KΩ nominal	A/CP Series (Type II): 10KΩ nominal	
A/1.8K Series: 1.8KΩ nominal	A/CSI Series: 10KΩ nominal												
A/3K Series: 3KΩ nominal	A/10KS Series: 10KΩ nominal												
A/AN Series (Type III): 10KΩ nominal	A/10K-E1 Series: 10KΩ nominal												
A/AN-BC Series: 5.238KΩ nominal	A/50K: 50KΩ nominal (Brown/Yellow)												
A/20K Series: 20KΩ nominal	A/100KS Series: 100KΩ nominal												
A/CP Series (Type II): 10KΩ nominal													
Accuracy 0-70°C (32-158°F):	+/-0.2°C (+/-0.36°F) except A/10K-E1 Series: +/-0.3°C (+/-0.54°F) A/1.8K Series: +/-0.5°C @ 25°C (77°F) and +/-1.0°C (+/-1.8°F)												
Stability:	Sensor Dependent; Contact ACI for more information on specific sensor												
Response Time (63% Step Change):	10 Seconds nominal												
Power Dissipation Constant:	3 mW/°C except A/1.8K Series: 1 mW/°C A/10K-E1 Series: 2 mW/°C												
LCD Display Supply Voltage:	+9 to 35 VDC / 24 VAC (50/60 Hz)												
LCD Display Supply Current/VA:	< 4 mA / 0.12 VA												
LCD Display Accuracy:	+/- 2°F or +/- 2°C @ 71°F (21.5°C) Typical												
LCD Display Descriptor Number of Digits:	°F (Fahrenheit) or °C (Celsius) 3 1/2 Segment Display												
LCD Display Life Expectancy:	50,000 Hours Minimum												
Set Point Specifications Set Point Indication:	See Ordering Grid options on back of Product Data Sheet												
Set Point Tolerance:	+/- 10% of Range												
Override Option:	Short Thermistor (Default); Field (Jumper) Selectable “Dry Contact” Closure (Separate Input); Short Set Point available upon request												
Operating Storage Temperature Range:	1.5 to 50°C (35 to 122°F) Non-LCD: -40 to 65°C (-40 to 149°F), LCD Display: -10 to 65°C (14 to 149°F)												
Operating Humidity Range:	10 to 95% RH, non-condensing												
Connections Wire Size:	Screw Terminal Blocks 16 (1.31 mm ²) to 26 (0.129 mm ²) AWG												
Terminal Block Torque Rating:	0.5 Nm (Minimum); 0.6 Nm (Maximum)												
Enclosure Material Color:	“R2” Enclosure: ABS; Plastic, White, UL94-HB “R” Enclosure: ABS Plastic, Beige UL94-HB												
Product Dimensions:	See Drawing on back of Product Data Sheet												
Product Weight:	A/XX-R/RS/RO Series: 0.14 lbs. (63.5g) A/XX-RSO Series: 0.18 lbs. (81.6g) A/XX-R2/R2S/R2O Series: 0.16 lbs. (72.6g) A/XX-R2SO Series: 0.20 lbs. (90.7g) All LCD Display Units: 0.18 lbs. (81.6g)												
Agency Approvals:	CE**, RoHS2, WEEE												

Note:** All LCD Display Units are not CE Compliant, but they are RoHS2 Compliant



DIMENSIONAL DRAWING

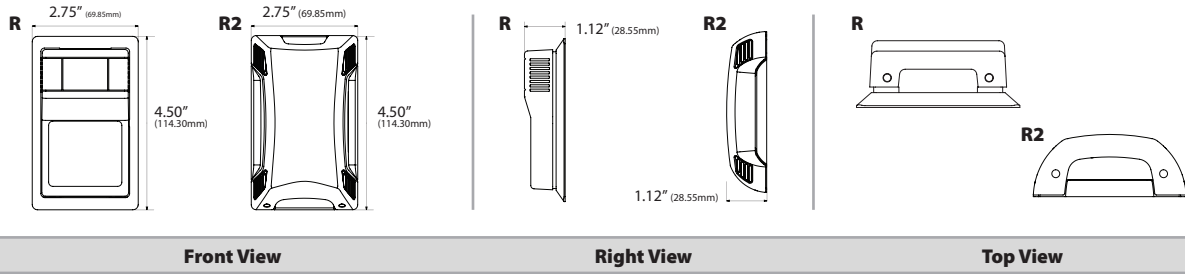

STANDARD ORDERING

Model # Example: A/CP -OR- 144212

Model #	Item #	Description
A/CP-R	144212	10K (Type II), "R" Version, Beige, No Options
A/CP-R2	144213	10K (Type II), "R2" Version, White, No Options
A/AN-R	144208	10K (Type III), "R" Version, Beige, No Options
A/AN-R2	144209	10K (Type III), "R2" Version, White, No Options
A/20K-R	144160	20K, "R" Version, Beige, No Options
A/20K-R2	144170	20K, "R2" Version, White, No Options

CUSTOM ORDERING

Model # Example: A/ 1.8K RS RJ6 LCD F A01 B4

MODEL #

A. Sensor Series No Selection Required	A/	A/
B. Model Series Select One (1)	1.8K 3K AN AN-BC CP CSI 10KS 10K-E1 20K 50K 100KS	
C. Configuration Select One (1)	R = Room RO = Room with Override RS = Room with Set Point RSO = Room with Set Point and Override R2 = Room R2O = Room with Override R2S = Room with Set Point R2SO = Room with Set Point and Override	
D. Communication Jack Select One (1)	---- = No Jack RJ4 = 4 Pin 4 Conductor RJ9, RJ10, or RJ22 Style Head Set Modular Connector RJ6 = 6 Pin 6 Conductor RJ12 Modular Phone Connector 232 = 3.5mm (1/8") Stereo Jack	
E. LCD Display Select One (1)	---- = No LCD Display LCD = With LCD Display (Only Available with "R" Style Enclosure)	
F. LCD Display Descriptor Select One (1)	F = °F (Fahrenheit) C = °C (Celsius)	
G. NIST** Select One (1)	---- = No NIST Certificate NIST = NIST Certificate (3 Points)	
Setpoint Configuration Options Select Options below if RS, RSO, R2S or R2SO was selected as a Configuration (C).		
1. Slidepots*** Select One (1)	Direct Acting (Range in Ohms) A01 = 0 to 100K A02 = 0 to 20K A03 = 0 to 10K A06 = 4.75K to 24.75K A07 = 10K to 30K A08 = 1K to 11K A09 = 0 to 2K A10 = 0 to 1K A11 = 2.05K to 3.05K A12 = 0 to 400 A16 = 0 to 5K A18 = 10K to 15K A20 = 6.19K to 26.19K A26 = 866 to 1,266 A29 = 7.87K to 27.8K Reverse Acting (Range in Ohms) A04 = 1051.1 to 51.1 A14 = 10K to 0 A24 = 9.5K to 1K	
2. Setpoint Stickers Select One (1)	A3 = 18-28 DEG C A4 = 20-30 DEG C B4 = 55-85 DEG F B7 = 60-90 DEG F C5 = COOL/WARM C6 = COOLER/WARMER D3 = WARM/COOL G5 = BLUE/RED (R2 Enclosure)	

Note 1: LCD Display is not compatible with NIST | **Note 2:** Short Sensor is our default but the Dry Contact option is field selectable with terminals included
Note 3: NIST is available in "R" and "R2" only configurations | **Note 4:** Other Setpoint configurations are available. Please contact ACI.

ACCESSORIES ORDERING

Model # Example: A/MOUNTING PLATE BEIGE R -OR- 106821

Model #	Item #	Description
A/MOUNTING PLATE BEIGE R	106821	Wall Mounting Back Plate, Plastic, Beige ("R")
A/MOUNTING PLATE WHITE R	126386	Wall Mounting Back Plate, Plastic, White ("R")
A/MOUNTING PLATE WHITE R2	143369	Wall Mounting Back Plate, Plastic, White ("R2")
LOCKING COVER	107370	Clear Thermostat Guard, Locking Cover, Low Profile
A/ROOM-FOAM-PAD	125690	1/8" Foam Insulation Pad with Adhesive (3" x 2", Black)

THE WORLD LEADER IN CLEAN AIR SOLUTIONS

PerfectPleat® SC M8

(Standard Capacity MERV 8)

EXTENDED SURFACE PLEATED PANEL FILTERS



- Mechanical efficiency – does not rely on eletret charge technology
- Self-supporting DuraFlex® media made from virgin fiber – no wire support needed
- Consistent media with controlled fiber size and blend
- Available in 2" and 4" models
- Environmentally friendly – no dies, no metal, fully incinerable
- Patented media, filter design, and manufacturing process. Patents covered under one or more of the following: US 6398839 B2; US 6254653 B1; US 6159318; US 6165242; US 6387140 B1

PerfectPleat SC M8 filters are designed to consistently increase efficiency throughout the service life of the filter. They have an initial MERV 8 rating respectively, but the efficiency increases significantly when dust loading begins. PerfectPleat SC M8 filters have distinctive self-supporting characteristics that allow a pleating pattern, which promotes airflow and maximizes Dust Holding Capacity (DHC). The PerfectPleat SC M8 filter is best suited for standard capacity pleated panel filter applications, where pleated filters are currently in use. They can also be used to upgrade applications using panel filters.

Superior Design and Construction

The perimeter frame is constructed from the highest wet-strength 28 pt. beverage carrier board, securely bonded to the media pack. Support straps on the air entering side are used in combination with uniquely designed pleat stabilizers on the air leaving side of the 2" model to provide additional strength. The support straps and pleat stabilizers ensure integrity against turbulent airflow. The 2" filter resists crushing and abuse and provides excellent lateral stability for installation in side access systems.

The 4" model utilizes a two piece die cut frame with integral pleat spacers on the air leaving side. Pleat spacing is controlled by straps bonded to the air entering side and the multiple rows of pleat spacers on the air leaving side. The pleat spacers also ensure the pleats remain open during use, maximizing filter life.

DuraFlex® Media—Patented Media Design

Uniform size virgin fibers are assembled in closely controlled blends to create a media that is both self-supporting and consistent in performance. When pleated, DuraFlex media will hold its shape without the wire support characteristic of conventional pleated filters. That means no potential for the formation of rust and safer handling. With the superior resiliency of DuraFlex media and no need for wire support, PerfectPleat SC M8 filters can sustain significant abuse and maintain their shape and pleat spacing. The absence of wire also makes the filter totally incinerable, which can simplify disposal.

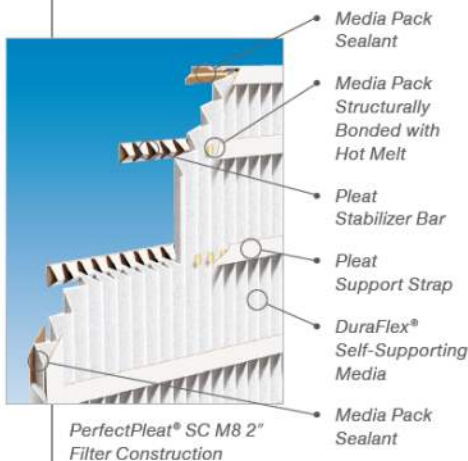

PerfectPleat® SC M8 Filters

Performance Data

Filter	Pleats Per Linear Foot	Rated Initial Resistance (in. w.g.)			Recommended Final Resistance (in. w.g.)	ASHRAE 52.2 MERV	Continuous Operating Temperature Limits
		300 FPM	500 FPM	625 FPM			
2" PerfectPleat SC M8	10	.13	.24	.33	1.0	8	150°F (66°C)
4" PerfectPleat SC M8	9	.11	.23	.35	1.0	8	200°F (93°C)

All performance data based on ASHRAE Standard 52.2. Performance tolerance conforms to Section 6.4 of ANSI/AHRI Standard 850-2013.

Underwriters Laboratories Classification – PerfectPleat filters are UL Classified. Testing was performed according to UL Standard 900.

Composite Minimum Efficiency Curve

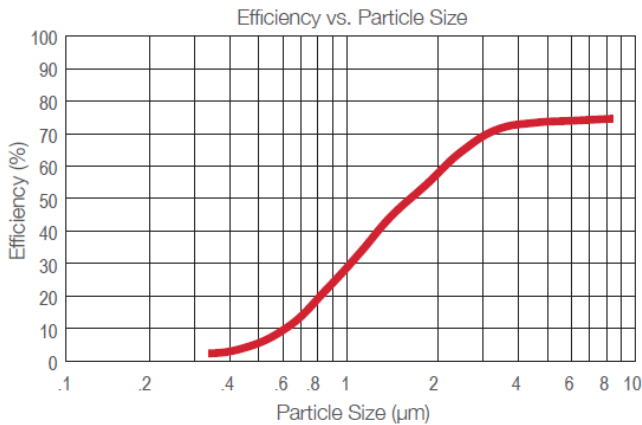

Initial Resistance vs. Filter Face Velocity

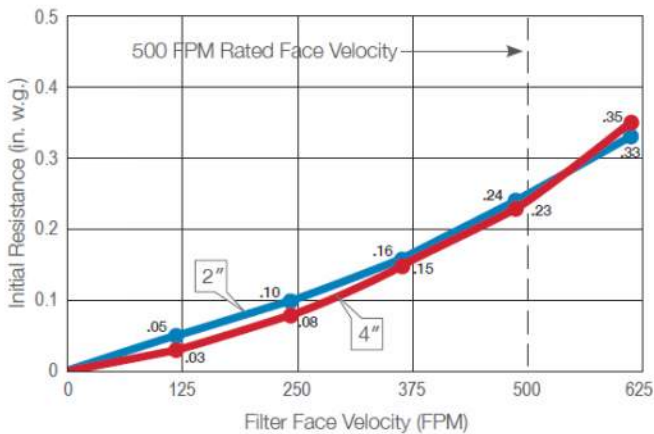

Product Information – Standard Sizes

Nominal Sizes (Inches) (W x H x D)	Actual Sizes (Inches) (W x H x D)	Rated Airflow (SCFM)			Pleats Per Filter
		300 FPM	500 FPM	625 FPM	
10 x 20 x 2	9½ x 19½ x 1¼	400	700	850	8
12 x 20 x 2	11½ x 19½ x 1¼	500	850	1050	10
12 x 24 x 2	11¾ x 23¾ x 1¼	600	1000	1250	10
14 x 25 x 2	13½ x 24½ x 1¼	750	1200	1500	11
15 x 20 x 2	14½ x 19½ x 1¼	650	1050	1300	12
15 x 25 x 2	14½ x 24½ x 1¼	800	1300	1650	12
16 x 16 x 2	15½ x 15½ x 1¼	550	900	1100	13
16 x 20 x 2	15½ x 19½ x 1¼	650	1100	1400	13
16 x 24 x 2	15¾ x 23¾ x 1¼	800	1350	1650	13
16 x 25 x 2	15½ x 24½ x 1¼	850	1400	1750	13
18 x 24 x 2	17¾ x 23¾ x 1¼	900	1500	1900	15
18 x 25 x 2	17½ x 24½ x 1¼	950	1550	1950	15
20 x 20 x 2	19½ x 19½ x 1¼	850	1400	1750	17
20 x 24 x 2	19¾ x 23¾ x 1¼	1000	1650	2100	17
20 x 25 x 2	19½ x 24½ x 1¼	1050	1750	2150	17
24 x 24 x 2	23¾ x 23¾ x 1¼	1200	2000	2500	20
25 x 25 x 2	24½ x 24½ x 1¼	1300	2150	2700	21
12 x 24 x 4	11¾ x 23¾ x 3¼	600	1000	1250	8
16 x 20 x 4	15¾ x 19¾ x 3¼	650	1100	1400	11
16 x 25 x 4	15¾ x 24¾ x 3¼	850	1400	1750	11
18 x 24 x 4	17¾ x 23¾ x 3¼	900	1500	1875	12
20 x 20 x 4	19¾ x 19¾ x 3¼	850	1400	1750	14
20 x 25 x 4	19¾ x 24¾ x 3¼	1050	1750	2150	14
24 x 20 x 4	23¾ x 19¾ x 3¼	1000	1650	2100	14
24 x 24 x 4	23¾ x 23¾ x 3¼	1200	2000	2500	17
25 x 29 x 4	24¾ x 28¾ x 3¼	1500	2500	3150	21

Energy savings may be realized by operating the PerfectPleat SC M8 filters to a lower final resistance. Contact your local AAF Flanders representative for a Total Cost Of Ownership analysis for your specific application.

PerfectPleat® and DuraFlex® are registered trademarks of AAF International in the U.S. and other countries.



AAF Flanders has a policy of continuous product research and improvement and reserves the right to change design and specifications without notice.

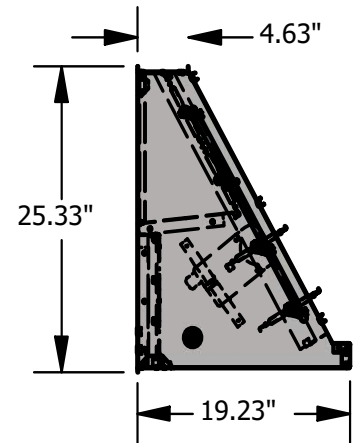
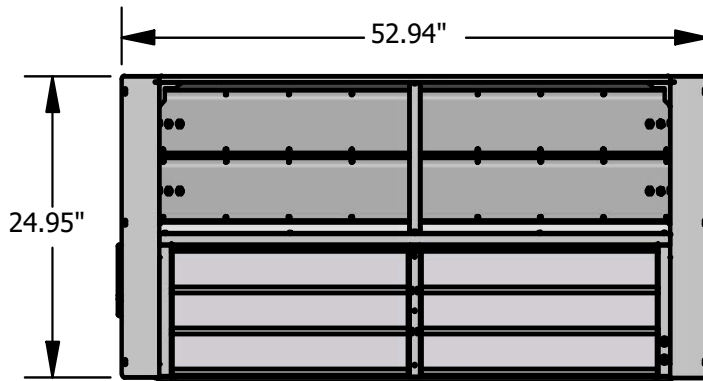
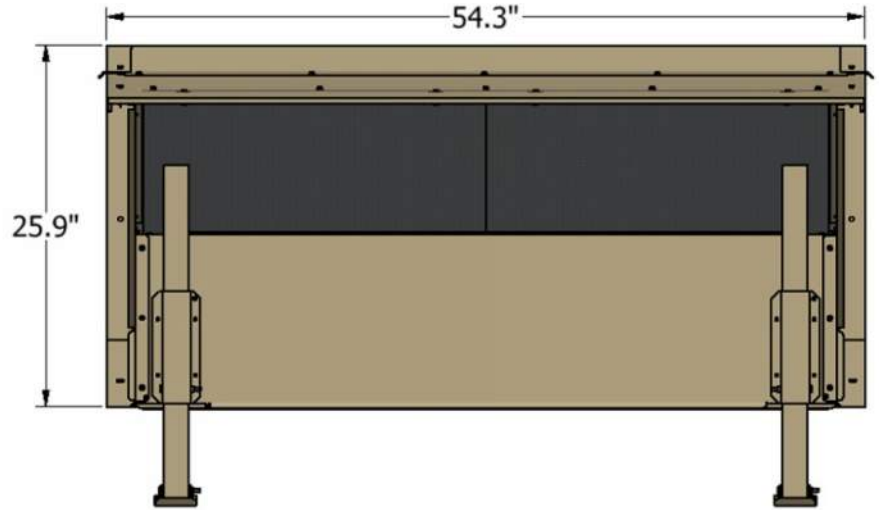
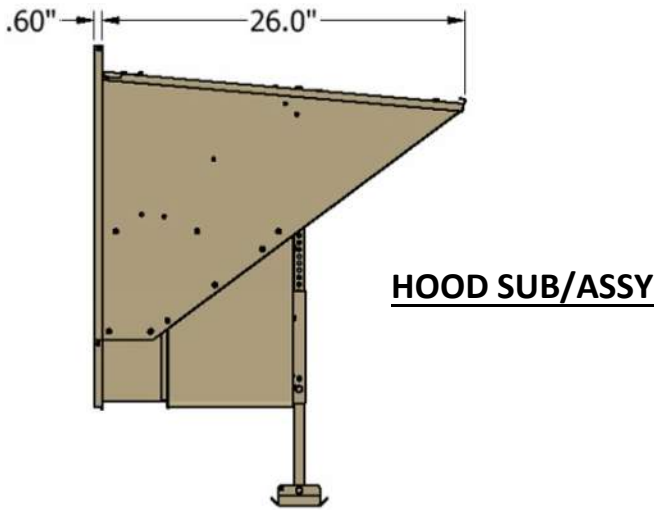

FEATURES

- Fully Modulating
- Up to 100% Fresh Air
- Integrated Barometric Relief
- Hoods Painted to Match Daikin Unit
- Adjustable Minimum Fresh Air
- Fuels 7.5-12.5 Tons
- 115 Pounds

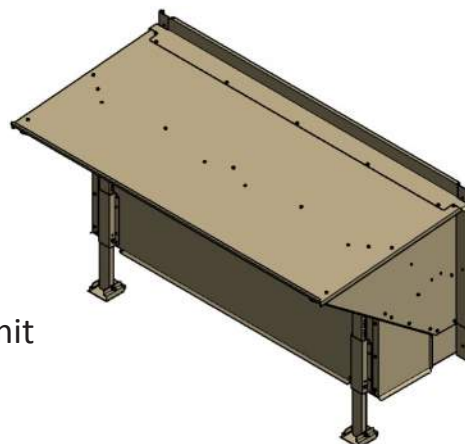

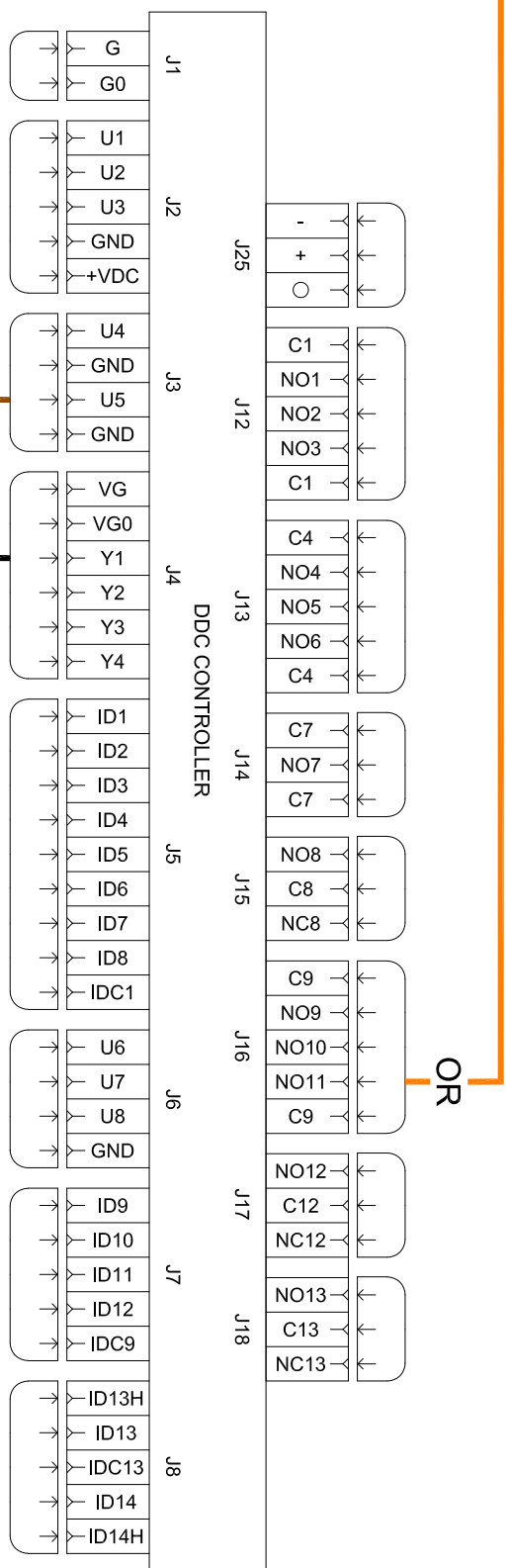

BLOWER STATUS

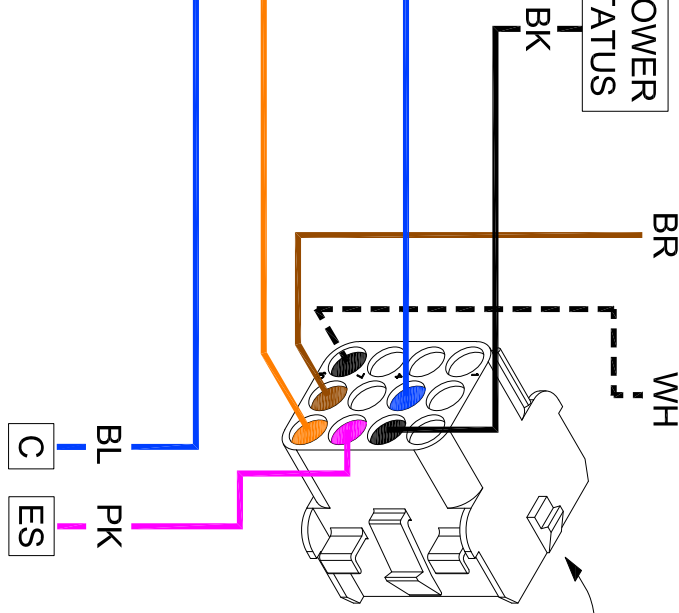

12-PIN DDC ECONOMIZER WIRE HARNESS

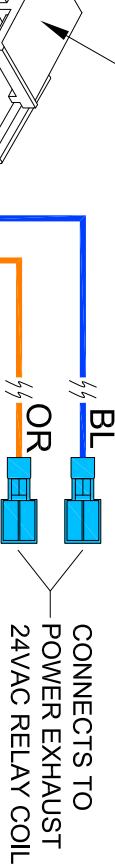

C BL ES
PK

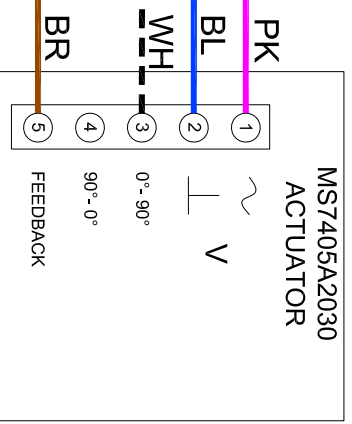

12X-DK-036090DDC WIRE DIAGRAM REV B 10/05/2023
 MODULATING DDC ECONOMIZER
 W/ MS7405A2030 ACTUATOR

(APPLIES TO 122/123/128-DK-036DDC & 122/123/128-DK-090DDC)

Instructions

Remove the guards from the box and inspect for damage. Secure the coil guards to the the unit covering the condenser coil using the included screw package. Each guard is numbered.

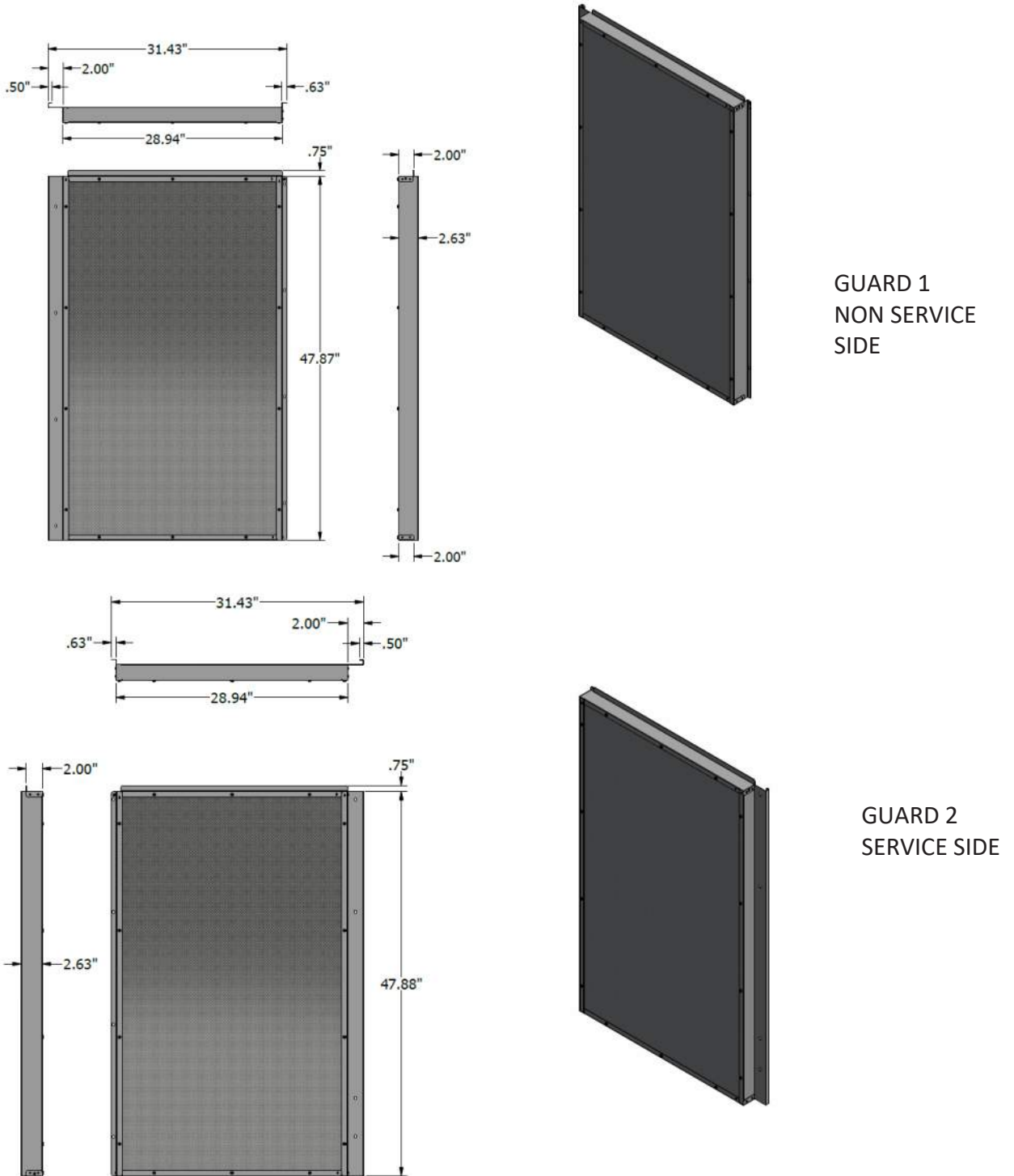

ATTENTION INSTALLING PERSONNEL

As a professional installer you have an obligation to know the product better than the customer. This includes all safety precautions and related items.

Prior to actual installation, thoroughly familiarize yourself with this Instruction Manual. Pay special attention to all safety warnings. Often during installation or repair it is possible to place yourself in a position which is more hazardous than when the unit is in operation.

Remember, it is **your** responsibility to install the product safely and to know it well enough to be able to instruct a customer in its safe use.

Safety is a matter of common sense...a matter of thinking before acting. Most dealers have a list of specific good safety practices...follow them.

The precautions listed in this Installation Manual are intended as supplemental to existing practices. However, if there is a direct conflict between existing practices and the content of this manual, the precautions listed here take precedence.

! WARNING

HIGH VOLTAGE!
TO AVOID THE RISK OF ELECTRICAL SHOCK, WIRING TO THE UNIT MUST BE POLARIZED AND GROUNDED.



! WARNING

HIGH VOLTAGE!
TO AVOID PERSONAL INJURY OR DEATH DUE TO ELECTRICAL SHOCK, DISCONNECT ELECTRICAL POWER BEFORE SERVICING OR CHANGING ANY ELECTRICAL WIRING.



IMPORTANT!

- A GFCI receptacle is different from conventional receptacles. In the event of a ground fault, a GFCI will trip and quickly stop the flow of electricity to prevent serious injury.
- A GFCI receptacle does NOT protect against circuit overloads, short circuits, or shocks. For example, you can still be shocked if you touch bare wires while standing on a non-conducting surface such as a wood floor.
- Your unit has been built with either a powered or non-powered 115V / 15A GFCI outlet for your convenience. This is to only be used while servicing the unit.
- Use this GFCI with copper or copper-clad wire. Do not use it with aluminum wire.
- Do not install this GFCI receptacle on a circuit that powers life support equipment because if the GFCI trips it will shut down the equipment.
- The GFCI receptacle must be kept dry by a weather proof cover and box at all times.
- Test the outlet before use to make sure it has not incurred any damage during shipping. Perform the *Operation Check* listed in this manual.

GFCI Features

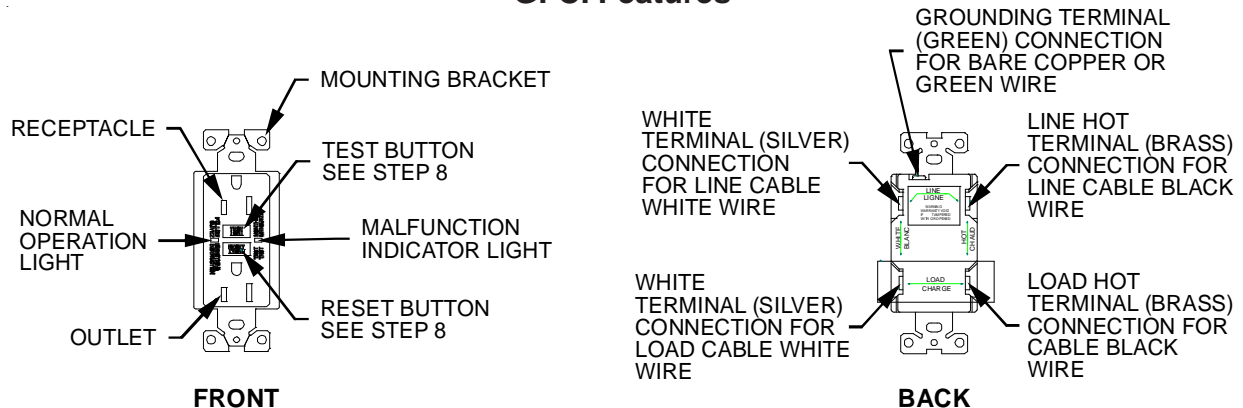

SCREW (TERMINAL) COLORS:
 GREEN = GROUNDING TERMINAL
 SILVER = WHITE TERMINALS
 BRASS = HOT TERMINALS



Your unit will have either a **powered** or **non-powered** GFCI outlet. If your unit has a factory-installed powered convenience outlet, the outlet is ready for use once the unit is installed and operating. See figure below for component locations of the powered outlet.

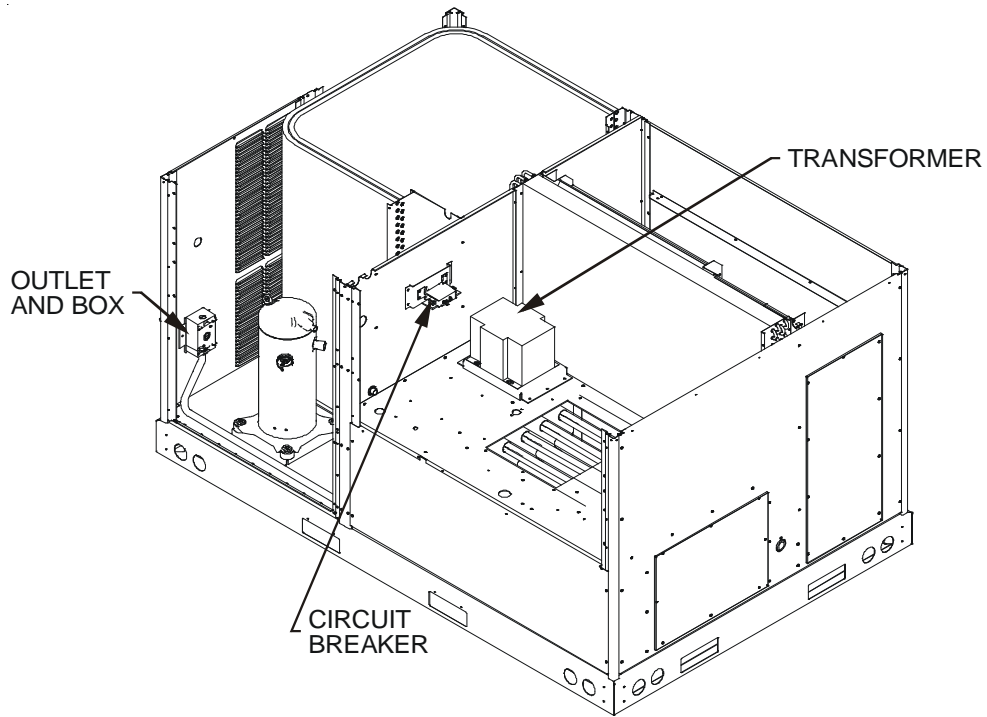

If the power for either needs to be altered from 230V to 208V, please review and follow the instructions listed on the outlet wiring diagram next to the unit diagram. Ensure unit power is OFF before making any wiring changes. See diagram below for your convenience.

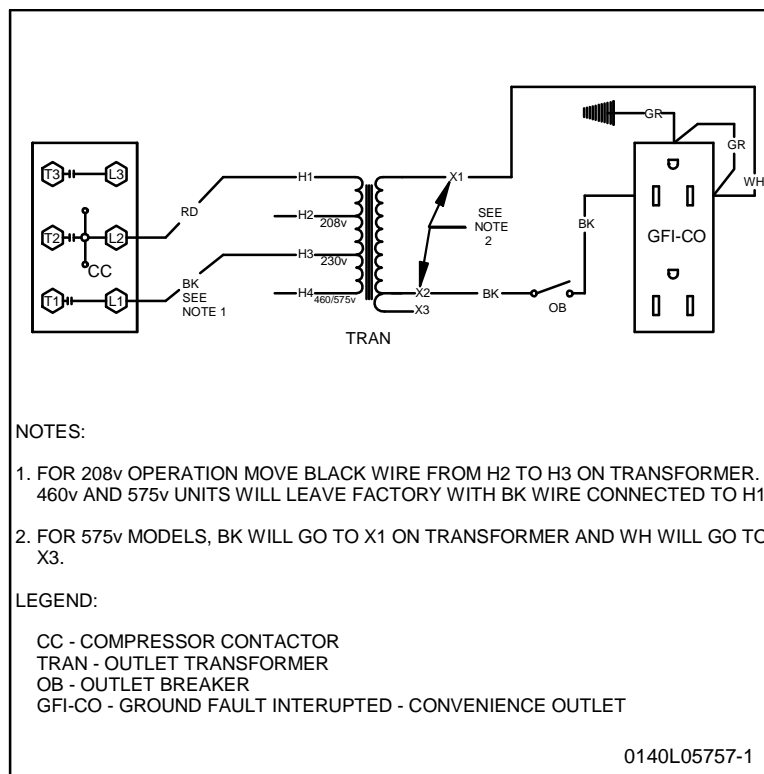

NOTE: There is a 15A breaker mounted to the indoor section of the unit. If outlet is not powered, check the breaker to make sure it is in the ON position. If the breaker has been tripped, check for shorts in the wiring.

NON-POWERED GFCI OUTLET INSTALLATION INSTRUCTIONS

1. Turn power OFF to unit and power source used to power the outlet.
2. Locate the outlet on your unit. It will be near the control box area.
3. Remove gasket and outlet.
4. Bring power into the outlet box as shown. Ensure the wiring is suitable for outdoor conditions. Connect the white wire to the WHITE terminal (Silver).
5. Connect the black wire to the HOT terminal (Brass).
6. Connect a 6-inch bare copper (or GREEN) 12 or 14 AWG wire to the grounding terminal on the GFCI, and a similar wire to the grounding terminal on the box. Connect the ends of these wires to the LINE cable's bare copper (or GREEN) wire using a wire connector.
7. Fold the wires into the box, keeping the grounding wire away from the WHITE and HOT terminals. Screw the receptacle to the box.
8. Install cover as per instructions.

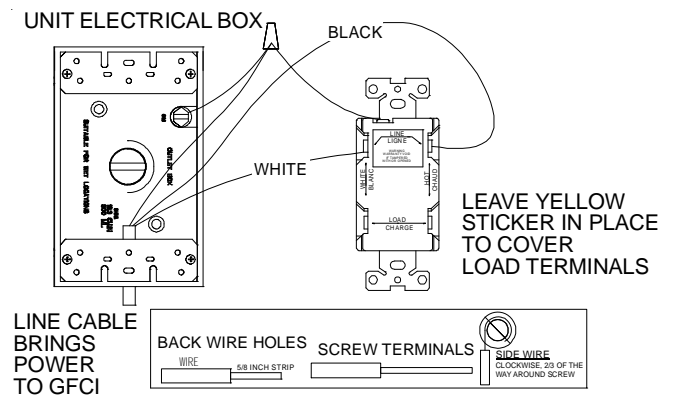
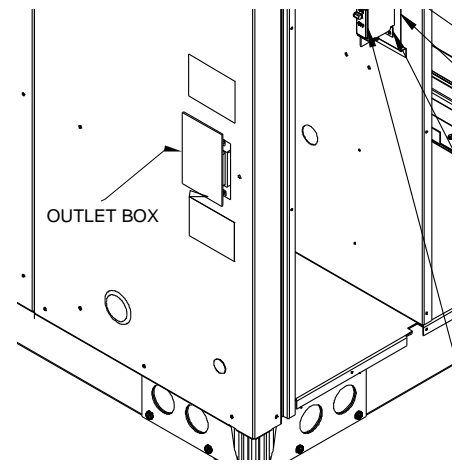

OPERATION CHECK

1. Turn power ON. Press the RESET button fully. Plug a lamp or radio into the GFCI (and leave it plugged-in) to verify that the power is ON.
2. Next, press the TEST button to trip the device. The radio or lamp should shut OFF and the RESET button will pop-out. To restore power, press the RESET button.
3. If the malfunction indicator light (end-of-life indicator LED) (red) lights, the GFCI has stopped functioning and needs to be replaced.

If the outlet does not work as described, turn power OFF and check the wire connections against the diagram shown above. Ensure that there are not loose wires or loose connections.

If the RESET button does not work, check the LINE and LOAD connections. They could be reversed. If there are no wiring mistakes, the receptacle could be damaged and will need to be replaced. If the connections are rewired to the GFCI, please perform the *Operation Check* again.

NOTE: There is a 15A breaker mounted to the indoor section of the unit. If outlet is not powered, check the breaker to make sure it is in the ON position. If the breaker has been tripped, check for shorts in the wiring.

Check the TEST and RESET buttons monthly to assure proper operation.

NON-POWERED AND POWERED GFCI OUTLET COVER INSTALLATION INSTRUCTIONS

1. Locate the outlet on your unit. It will be near the control box area.
2. Remove the gasket.
3. Install the GFCI outlet cover as shown.
4. The outlet cover is shipped with the unit and could be found in control box or blower deck.

ASSEMBLY INSTRUCTIONS: Numbers in parenthesis reflect the balloon numbers on the drawing.

1. Apply gasket (ITEM 6) to base (ITEM 2).
2. Apply adhesive, LOCTITE 4204 or 4205, (ITEM 13) into cord flap gasket slot of cover (ITEM 1) and base (ITEM 2). See gasket slot detail.

3. Insert cord flaps (ITEM 12) into slots of cover and base within 15 seconds of step 2 above. Ensure cord flaps are fully seated and top of flap is flush with the top of cord opening of cover and base. See cord opening detail. Presence of adhesive should not be apparent on any exposed surface of installed cord flap gasket.
4. Snap cover (ITEM 1) to base (ITEM 2).
5. Place wallplates (ITEM 3 & 4) into assembled unit.
6. Place bagged mounting screws (ITEM 5) into assembled unit.
7. Place instruction sheet (ITEM 8) into assembled unit.
8. Close assembled unit.
9. Place assembled unit into packaging bag (ITEM 7).
10. Seal packaging bag (ITEM 7).
11. Place sealed bags into carton (ITEM 10), four rows of three.
12. Place label (ITEM 9) on carton (ITEM 10).
13. Insert quality flyer (ITEM 11).

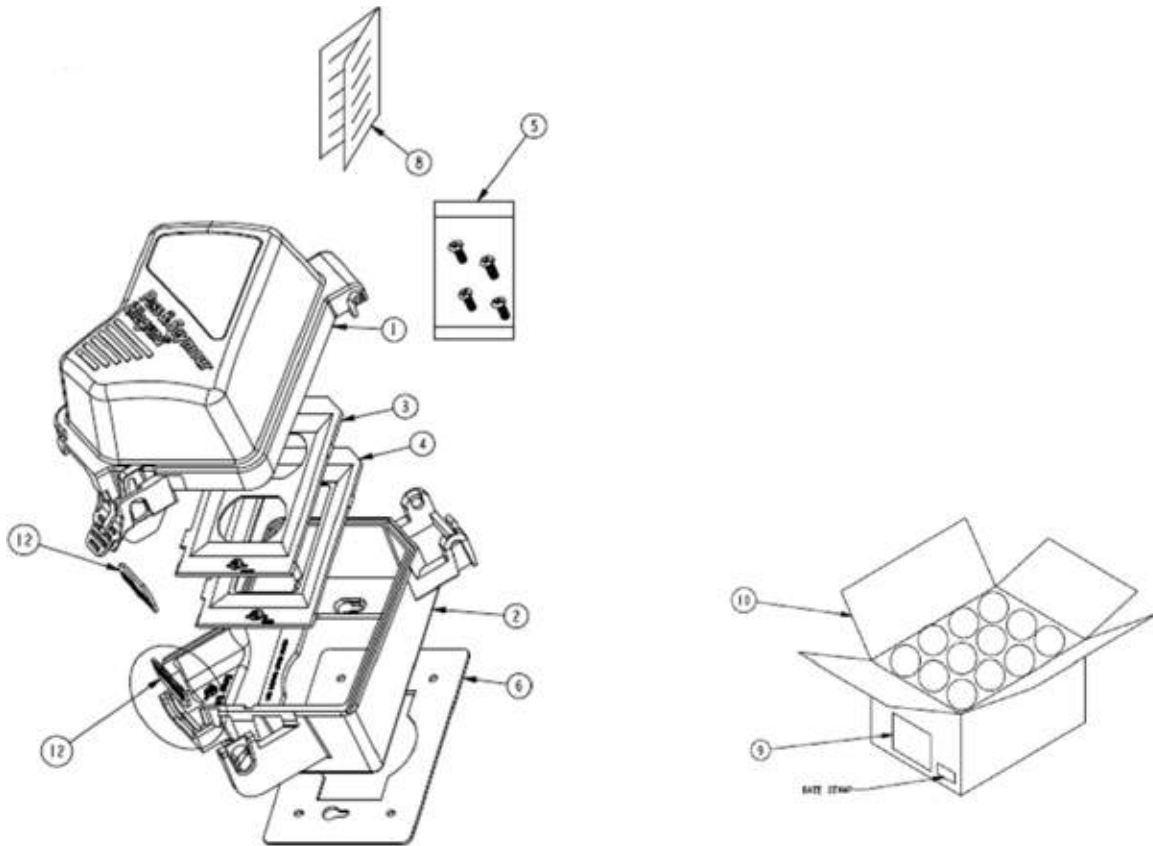

NOTE: SPECIFICATIONS AND PERFORMANCE DATA LISTED HEREIN ARE SUBJECT TO CHANGE WITHOUT NOTICE

Quality Makes the Difference!

All of our systems are designed and manufactured with the same high quality standards regardless of size or efficiency. We have designed these units to significantly reduce the most frequent causes of product failure. They are simple to service and forgiving to operate. We use quality materials and components. Finally, every unit is run tested before it leaves the factory. That's why we know. . . **There's No Better Quality.**

Visit our website at www.daikincomfort.com for information on:

- Products
- Warranties
- Customer Services
- Parts
- Contractor Programs and Training
- Financing Options

© 2013, 2015-2016 **DAIKIN MANUFACTURING COMPANY, L.P.**

Project Name:	Approval:
Location:	Date:
Engineer:	Construction:
Submitted to:	Unit #:
Submitted by:	Drawing #:
Reference:	

MODEL COMPATIBILITY:

Compatible with Light Commercial models: 3 to 12.5 ton High Efficiency (DR* series), 15 to 25 ton Standard Efficiency (DB* series)

SPECIFICATIONS:

PRODUCT IMAGE:



Model	0130M00579	0130M00580
Description	Daikin iLINQ DDC Controller - Standard	Daikin iLINQ DDC Controller - with MHGRH Control
Dimensions	12.4 x 5.2 x 2.8 inches	
Operating Conditions	-4°F to 140°F, 90% RH non-condensing	
Storage Conditions	-22°F to 158°F, 90% RH non-condensing	
Supply Voltage	Dedicated class 2 transformer 24VAC (+10/-15%), 45 VA	
Wiring specs	18 to 22 AWG twisted pair or shielded cable for all sensor installations	
Temperature Inputs	Type III thermistor, 10K Ω @ 77°F	
Analog Inputs (AI)	0 – 10VDC, Input Precision ±0.3% Full Scale	
Number of AIs	8	10
Digital Inputs (DI)	24VAC (+10/-15%) 50/60HZ, Absorbed Current: 5mA	
Number of DIs	14	18
Analog Outputs (AO)	0 – 10Vdc, External Power Supply: 24VAC (+10/-15%), Precision: ±2% Full Scale, Resolution: 8 Bit, Maximum Load: 10mA	
Number of AOs	4	6
Digital Outputs (DO)	8A/250VAC Resistive Load	
Number of DOs	13	18
USB Type “B” Port	1 for Programming, Setup, and Advanced Diagnostics	
USB Type “A” Port	1 for Transferring files	
Ethernet Ports	2 autocross 10/100 MBPS port for BACnet/IP communication and Web Interface	
BACnet/IP Communication	Built-in BACnet/IP (Ethernet port)	
BACnet MS/TP Communication	Built-in RS485 port, Baud rate select from 9600, 19200, 38400 (Default), 57600, and 76800	
LonWorks Communication	Optional communication card (0130M00584) required	
Compliance	UL Listed / CUL Listed BTL Certified (B-BC) California Title 24 certified economizer control	

Daikin North America LLC, 5151 San Felipe, Suite 500, Houston TX, 77056

www.daikinac.com www.daikincity.com

(Daikin's products are subject to continuous improvements. Daikin reserves the right to modify product design, specifications and information in this data sheet without notice and without incurring any obligations)



Submittal Data Sheet

0130M00579/0130M00580– Daikin iLINQ DDC Controller

Project Name: _____	Approval: _____
Location: _____	Date: _____
Engineer: _____	Construction: _____
Submitted to: _____	Unit #: _____
Submitted by: _____	Drawing #: _____
Reference: _____	

OPTIONS:

Type	Name	Part Number	Function
Module	MHGRH Expansion Module	0130M00581	Used for 0130M00580 only DDC Controller expansion module for control of the Modulating Hot Gas Reheat (MHGRH) valve
	LonWorks Communication Card	0130M00584	Communication card allowing connection of the DDC Controller to a LonWorks network
Sensors	Space CO ₂ Sensor	0130L00225	Sensor installed on wall to monitor space CO ₂ level. A CO ₂ sensor is required for demand control ventilation. Sensor output range 0-10Vdc, 0-2000ppm
	Duct CO ₂ Sensor	0130L00220	Sensor installed in return air duct to monitor space CO ₂ level. A CO ₂ sensor is required for demand control ventilation. Sensor output range 0-10Vdc, 0-2000ppm
	Duct Temperature Sensor 4"	0130L00222	Sensor installed in return air or supply air duct to monitor temperature. When installed in the return air duct, this sensor can be used in place of the wall mounted temperature sensor. Sensor type is 10KΩ Type III Thermistor
	Duct Temperature Sensor 8"	0130L00228	
	Duct Temperature and Humidity Sensor	0130L00221	Sensor installed in return air duct to monitor space temperature and humidity level. This sensor can be used in place of the wall mounted temperature and humidity sensor. Temperature sensor type 10KΩ Type III Thermistor. Humidity sensor range 0-10Vdc, 0-100%RH
	Outdoor Air Temperature Sensor	0130L00227	Sensor installed to monitor outdoor air temperature. Sensor type 10KΩ Type III Thermistor
	Outdoor Air Temperature and Humidity Sensor	0130L00223	Sensor installed to monitor outdoor temperature and humidity levels. This sensor can be used in place of the outdoor temperature sensor when humidity must also be monitored. Temperature sensor type 10KΩ Type III Thermistor. Humidity sensor range 0-10Vdc, 0-100%RH
	Space Temperature Sensor	0130L00226	Sensor installed on wall to monitor space temperature. This sensor also provides local setpoint adjustment and a temporary occupancy override button. Sensor type 10KΩ Type III Thermistor
	Space Temperature and Humidity Sensor	0130L00224	Sensor installed on wall to monitor space temperature and humidity levels. This sensor can be used in place of the wall mounted temperature sensor when humidity must also be monitored. This sensor also provides local setpoint adjustment and a temporary occupancy override button. Temperature sensor type 10KΩ Type III Thermistor. Humidity sensor range 0-10Vdc, 0-100%RH

Daikin North America LLC, 5151 San Felipe, Suite 500, Houston TX, 77056
www.daikinac.com www.daikincity.com

(Daikin's products are subject to continuous improvements. Daikin reserves the right to modify product design, specifications and information in this data sheet without notice and without incurring any obligations)



Submittal Data Sheet

0130M00579/0130M00580– Daikin iLINQ DDC
Controller

Project Name: _____

Location: _____

Engineer: _____

Submitted to: _____

Submitted by: _____

Reference: _____

Approval: _____

Date: _____

Construction: _____

Unit #: _____

Drawing #: _____

FEATURES:

- Packaged RTU control:
 - Single speed, two speed, and variable (5) speed blower configurations
 - Blower proving switch software interlock
 - 1 or 2 stages of heating with PID control load calculation
 - Gas, electric stages, electric with SCR control, and heat pump heating configurations
 - 1 or 2 stages of cooling with PID control load calculation
 - 1, 2 or 4 compressors with pressure switch feedback and alarms
 - Lead / lag compressor priority rotation based on runtime
 - Independent defrost of condenser coils
 - Demand defrost interval calculation
- Staged auxiliary electric heat during defrost or when heat pump heating is locked out
- Dehumidification using Modulating Hot Gas Reheat (MHGRH)
- Low suction pressure freeze protection on units with MHGRH dehumidification
- Low ambient condenser fan control on units with MHGRH dehumidification
- Demand control ventilation
- Exhaust fan enable
- Dirty filter alarm
- Emergency shutdown interlock and alarm
- Remote start/stop
- Load shedding
- Local time scheduling, including weekly and holiday events
- Automatic daylight savings time adjustment
- Optimal start / optimal stop
- Onboard trend log storage can be exported to .csv file for analysis
- Live trend logs viewable via web interface
- Selectable TSTAT mode allowing for connection to standard TSTAT, bypassing some of the DDC control logic
- BACnet MS/TP or BACnet IP communication
- LonWorks communication with optional field installed module
- Web interface for commissioning or monitoring through any web browser
- Onboard LCD display for local commissioning or monitoring

Daikin North America LLC, 5151 San Felipe, Suite 500, Houston TX, 77056

www.daikinac.com www.daikincity.com

(Daikin's products are subject to continuous improvements. Daikin reserves the right to modify product design, specifications and information in this data sheet without notice and without incurring any obligations)

Project Name: _____
 Location: _____
 Engineer: _____
 Submitted to: _____
 Submitted by: _____
 Reference: _____

Approval: _____
 Date: _____
 Construction: _____
 Unit #: _____
 Drawing #: _____

SYSTEM DIAGRAM:

- Ethernet Network (Web Interface or BACnet/IP Communication):
 - The controller can be connected to a network switch or PC individually

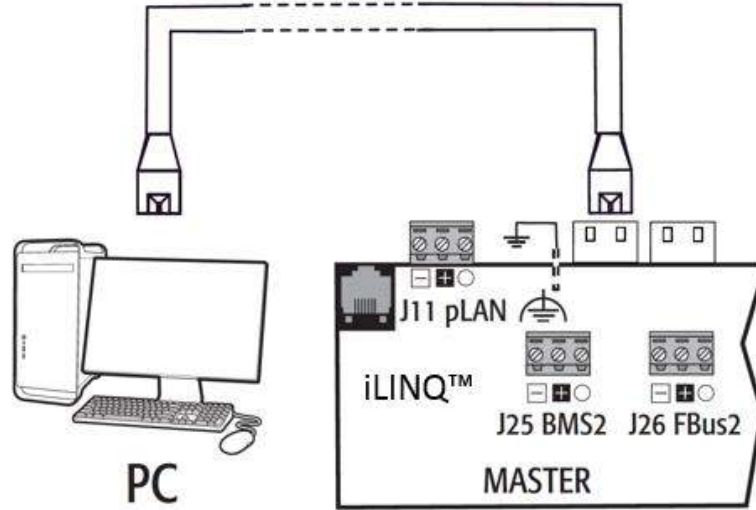

- Multiple controller can be daisy-chained together to a network switch or PC utilizing the second Ethernet port.

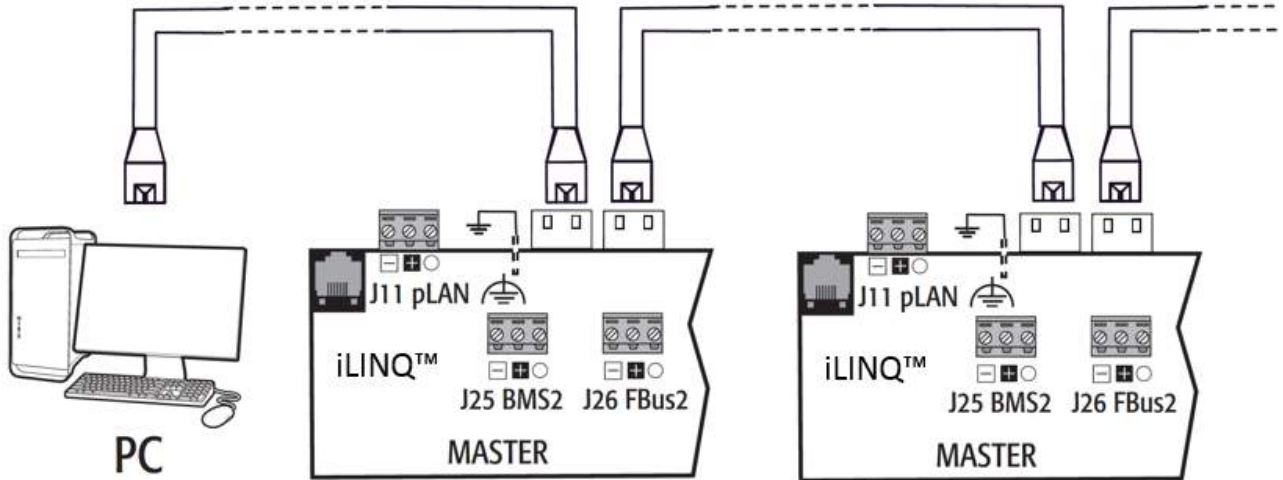

- BACnet MS/TP Network

Daikin North America LLC, 5151 San Felipe, Suite 500, Houston TX, 77056
www.daikinac.com www.daikincity.com

(Daikin's products are subject to continuous improvements. Daikin reserves the right to modify product design, specifications and information in this data sheet without notice and without incurring any obligations)

Project Name: _____
 Location: _____
 Engineer: _____
 Submitted to: _____
 Submitted by: _____
 Reference: _____

Approval: _____
 Date: _____
 Construction: _____
 Unit #: _____
 Drawing #: _____

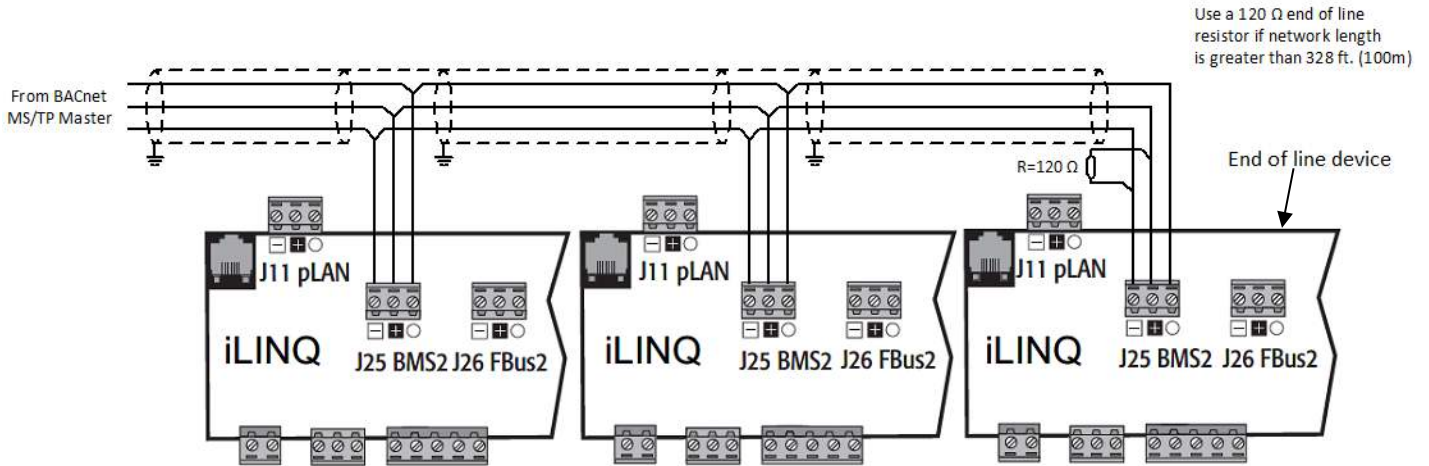

• LonWorks Network

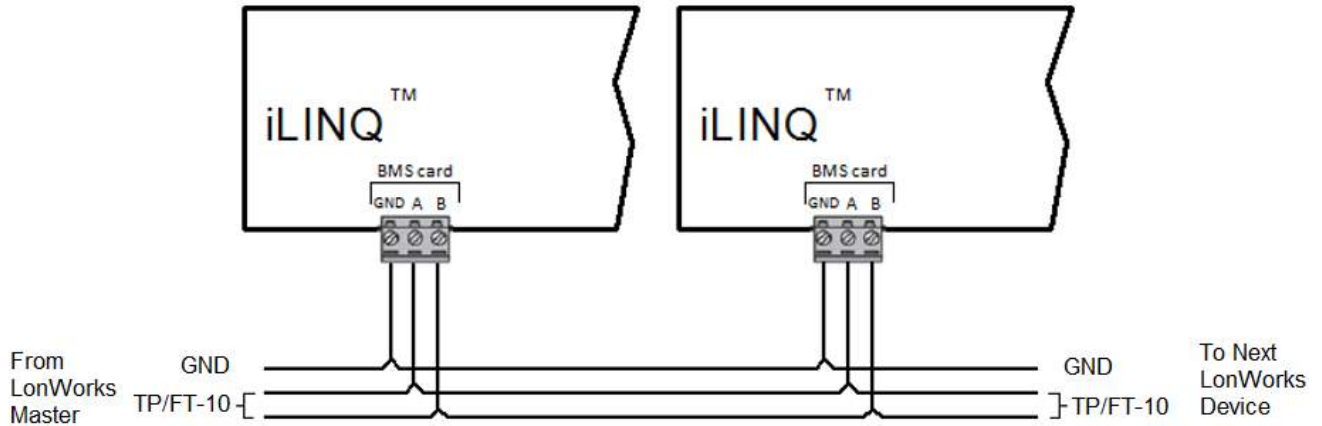

Daikin North America LLC, 5151 San Felipe, Suite 500, Houston TX, 77056
www.daikinac.com www.daikincity.com

(Daikin's products are subject to continuous improvements. Daikin reserves the right to modify product design, specifications and information in this data sheet without notice and without incurring any obligations)

Project Name: _____
 Location: _____
 Engineer: _____
 Submitted to: _____
 Submitted by: _____
 Reference: _____

Approval: _____
 Date: _____
 Construction: _____
 Unit #: _____
 Drawing #: _____

I/O LAYOUT:

- IO Layout Medium (0130M00579):

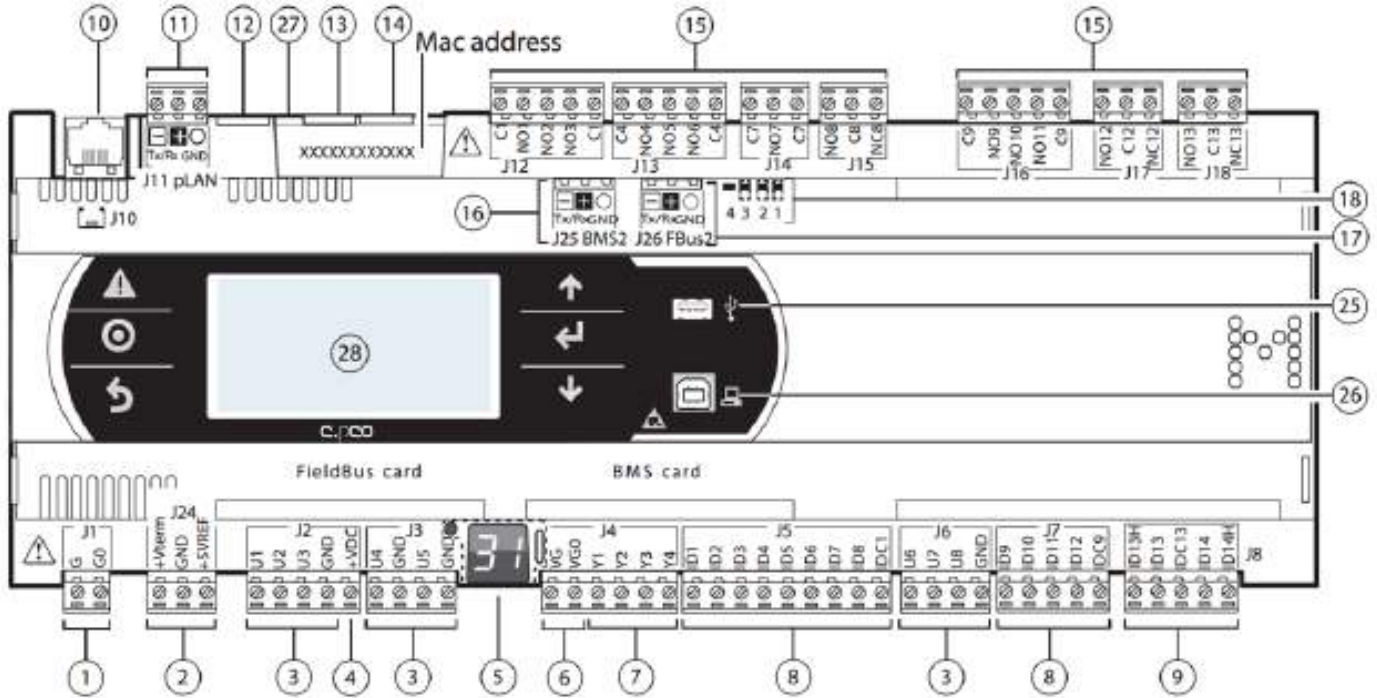

Daikin North America LLC, 5151 San Felipe, Suite 500, Houston TX, 77056
www.daikinac.com www.daikincity.com

(Daikin's products are subject to continuous improvements. Daikin reserves the right to modify product design, specifications and information in this data sheet without notice and without incurring any obligations)

Project Name: _____
 Location: _____
 Engineer: _____
 Submitted to: _____
 Submitted by: _____
 Reference: _____

Approval: _____
 Date: _____
 Construction: _____
 Unit #: _____
 Drawing #: _____

• IO Layout Large (0130M00580):

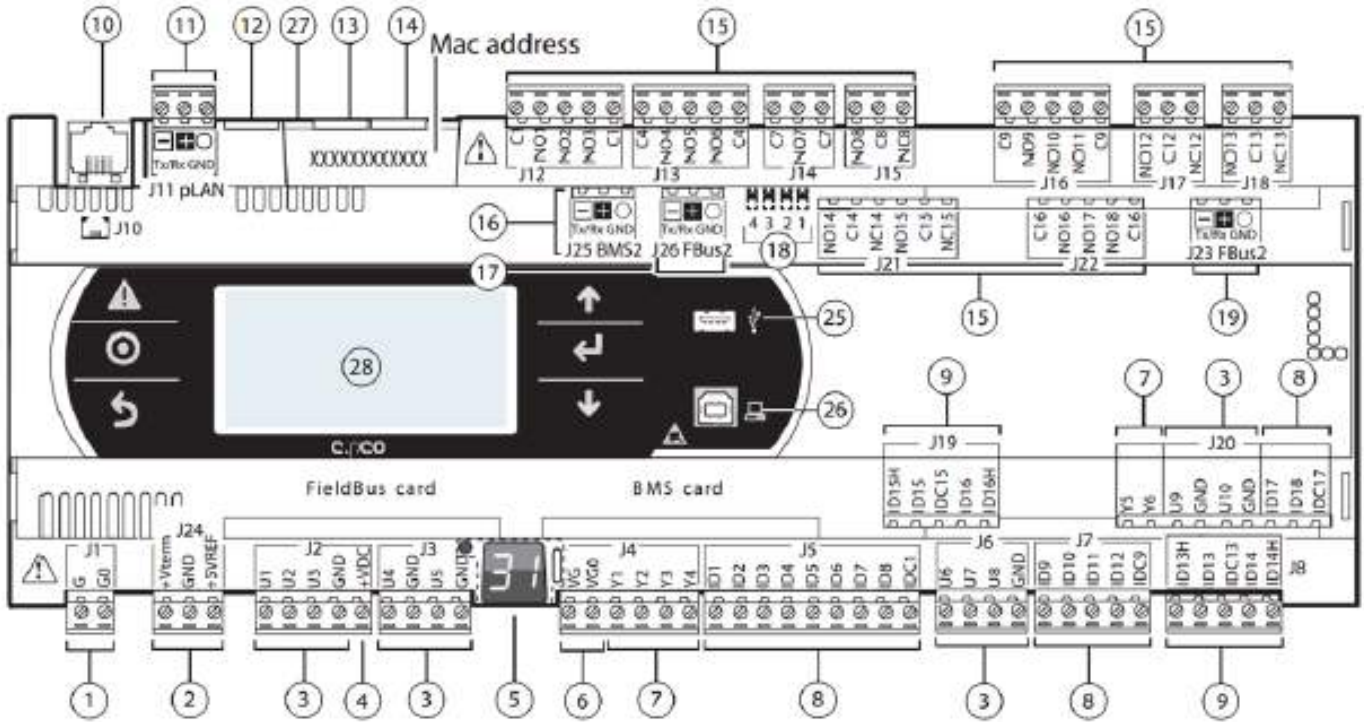

REF	DESCRIPTION	REF	DESCRIPTION
1	Power Connector [G(+), G0(-)]	13	Ethernet Port 1
2	+VTERM: Terminal Power Supply +5VREF: 5VDC Probe Power Supply	14	Ethernet Port 2
3	Analog Inputs	15	Relay Outputs
4	+VDC: 24VDC Power For Active Probes	16	BMS Port
5	pLAN Address LED	17	Fieldbus Port
6	24VAC Power Input For Analog Outputs	18	Fieldbus/BMS Jumpers
7	Analog Outputs	19	Fieldbus Port
8	Digital Inputs	25	USB Host Port
9	Digital Inputs	26	USB Device Port
10	pLAN Connection For Room Terminal	27	Earth Ground Connection
11	pLAN Connection For Room Terminal	28	Display and Keypad
12	Reserved		



Submittal Data Sheet

0130M00579/0130M00580– Daikin iLINQ DDC Controller

Project Name: _____
Location: _____
Engineer: _____
Submitted to: _____
Submitted by: _____
Reference: _____

Approval: _____
Date: _____
Construction: _____
Unit #: _____
Drawing #: _____

DIMENSIONS:

The physical dimension for the medium and large controllers are the same (inches):

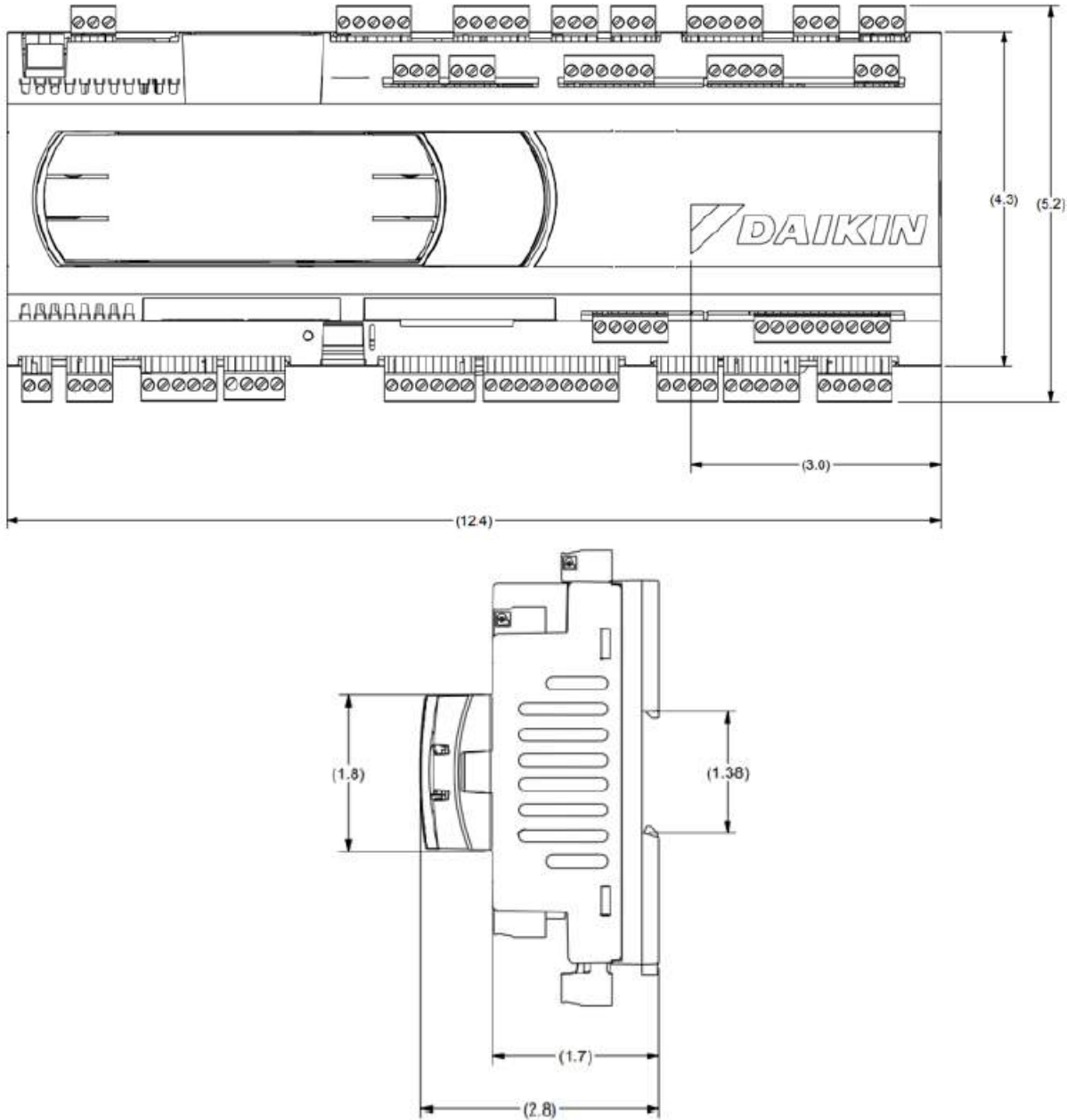

Daikin North America LLC, 5151 San Felipe, Suite 500, Houston TX, 77056

www.daikinac.com www.daikincity.com

(Daikin's products are subject to continuous improvements. Daikin reserves the right to modify product design, specifications and information in this data sheet without notice and without incurring any obligations)



Submittal Data Sheet

0130M00579/0130M00580– Daikin iLINQ DDC Controller

Project Name: _____	Approval: _____
Location: _____	Date: _____
Engineer: _____	Construction: _____
Submitted to: _____	Unit #: _____
Submitted by: _____	Drawing #: _____
Reference: _____	

DOCUMENTATION:

Documentation available on www.daikincity.com and/or www.daikinac.com:

- User Manual
- Quick Start Guide
- BACnet Design Guide
- LonWorks Design Guide
- Submittal
- Product Flyer

Daikin North America LLC, 5151 San Felipe, Suite 500, Houston TX, 77056
www.daikinac.com www.daikincity.com

(Daikin's products are subject to continuous improvements. Daikin reserves the right to modify product design, specifications and information in this data sheet without notice and without incurring any obligations)

FACTORY INSTALLED ELECTRICAL DISCONNECTS INSTALLATION INSTRUCTIONS

© 2013, 2019 **DAIKIN MANUFACTURING COMPANY, L.P.**
5151 San Felipe, Suite 500, Houston, TX 77056
www.daikinac.com
P/N: IOD-7002A Date: JULY 2019

DESCRIPTION

This Installation and Operation manual covers Factory Installed Electrical Disconnects for Daikin Commercial Package Units.

WARNING

ONLY PERSONNEL THAT HAVE BEEN TRAINED TO INSTALL, ADJUST, SERVICE OR REPAIR (HEREINAFTER, "SERVICE") THE EQUIPMENT SPECIFIED IN THIS MANUAL SHOULD SERVICE THE EQUIPMENT. THE MANUFACTURER WILL NOT BE RESPONSIBLE FOR ANY INJURY OR PROPERTY DAMAGE ARISING FROM IMPROPER SERVICE OR SERVICE PROCEDURES. IF YOU SERVICE THIS UNIT, YOU ASSUME RESPONSIBILITY FOR ANY INJURY OR PROPERTY DAMAGE WHICH MAY RESULT. IN ADDITION, IN JURISDICTIONS THAT REQUIRE ONE OR MORE LICENSES TO SERVICE THE EQUIPMENT SPECIFIED IN THIS MANUAL, ONLY LICENSED PERSONNEL SHOULD SERVICE THE EQUIPMENT. IMPROPER INSTALLATION, ADJUSTMENT, SERVICING OR REPAIR OF THE EQUIPMENT SPECIFIED IN THIS MANUAL, OR ATTEMPTING TO INSTALL, ADJUST, SERVICE OR REPAIR THE EQUIPMENT SPECIFIED IN THIS MANUAL WITHOUT PROPER TRAINING MAY RESULT IN PRODUCT DAMAGE, PROPERTY DAMAGE, PERSONAL INJURY OR DEATH.

ATTENTION INSTALLING PERSONNEL

As a professional installer, you have an obligation to know the product better than the customer. This includes all safety precautions and related items.

Prior to actual installation, thoroughly familiarize yourself with this Instruction Manual. Pay special attention to all safety warnings. Often during installation or repair, it is possible to place yourself in a position which is more hazardous than when the unit is in operation.

Remember, it is your responsibility to install the product safely and to know it well enough to be able to instruct a customer in its safe use.

Safety is a matter of common sense...a matter of thinking before acting. Most dealers have a list of specific good safety practices...follow them.

The precautions listed in this Installation Manual are intended as supplemental to existing practices. However, if there is a direct conflict between existing practices and the content of this manual, the precautions listed here take precedence.

WARNING

HIGH VOLTAGE!

TO AVOID THE RISK OF ELECTRICAL SHOCK, WIRING TO THE UNIT MUST BE POLARIZED AND GROUNDED.



PANEL / HANDLE INSTALLATION INSTRUCTIONS

NOTE: All field wiring must be per the National Electric Code. Use Copper Conductors only.

WARNING

HIGH VOLTAGE!

DISCONNECT ALL POWER BEFORE SERVICING OR INSTALLING THIS UNIT. MULTIPLE POWER SOURCES MAY BE PRESENT. FAILURE TO DO SO MAY CAUSE PROPERTY DAMAGE, PERSONAL INJURY OR DEATH.



1. Remove disconnect panel from unit making sure to keep the panel mounting screws.
2. Remove "label" that is covering the Disconnect Shaft opening.
3. Route field wiring through the wire inlet and connect to the top lugs of the disconnect switch (Figure 1). **NOTE:** Disconnect switches are functional in any position. Some might be mounted "upside down". Field wiring should connect in the top as shown.

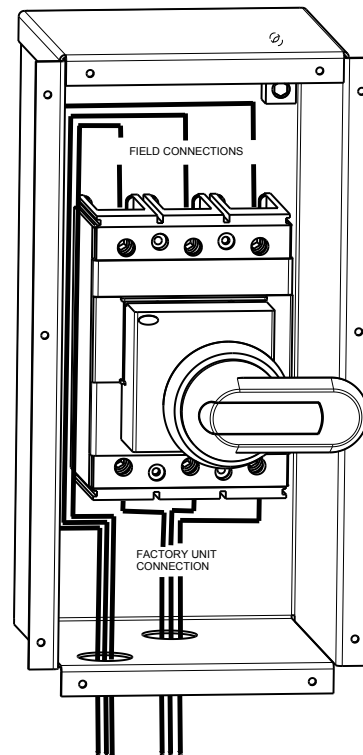

Figure 1

NOTE: For illustration purposes ONLY.
Unit may not be exactly as shown.



4. Attach Handle Assembly to Disconnect Panel with handle oriented as shown in Figure 2. Make sure the handle is in the "OFF" position.

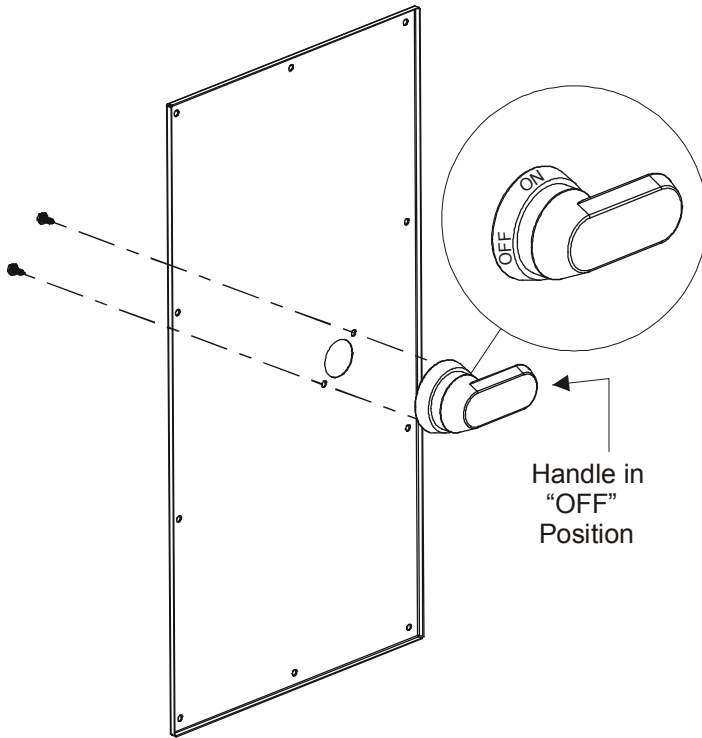

Figure 2

6. Align shaft with the opening in the Handle Assembly and slide Panel/Handle Assembly into place.
7. Secure the panel with the panel mounting screws (Figure 4).

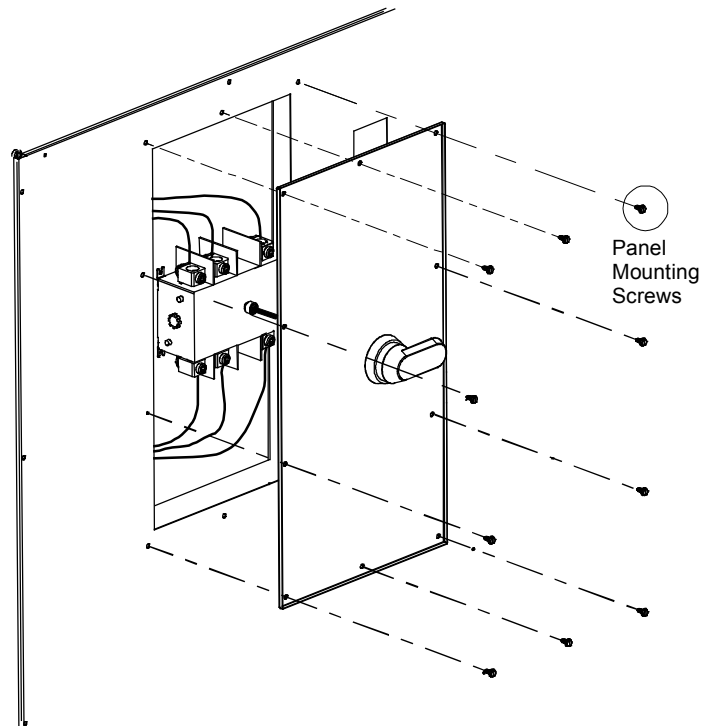

Figure 4

5. Insert "shaft" into the opening on the DISCONNECT SWITCH (Figure 3). Make sure switch is in the "OFF" position (rotated fully counter-clockwise). The "pin" at the handle end of the shaft will be in the horizontal position.

NOTE: Some shafts have a "chamfer" along one edge. This chamfer should be oriented to the "bottom left" when the switch is in the "OFF" position.

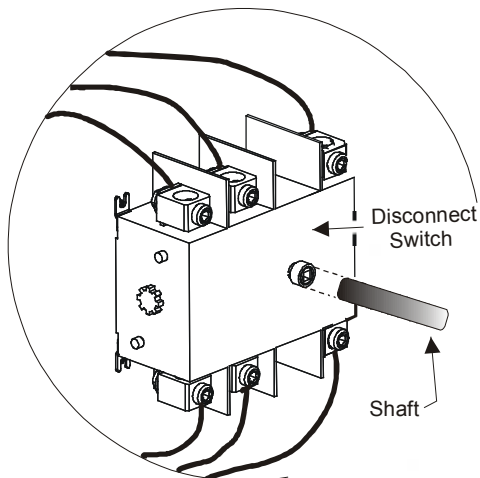

Figure 3

APPENDIX A WIRING DIAGRAM

HIGH VOLTAGE!
DISCONNECT ALL POWER BEFORE SERVICING OR INSTALLING THIS UNIT. MULTIPLE POWER SOURCES MAY BE PRESENT. FAILURE TO DO SO MAY CAUSE PROPERTY DAMAGE, PERSONAL INJURY OR DEATH.

WARNING



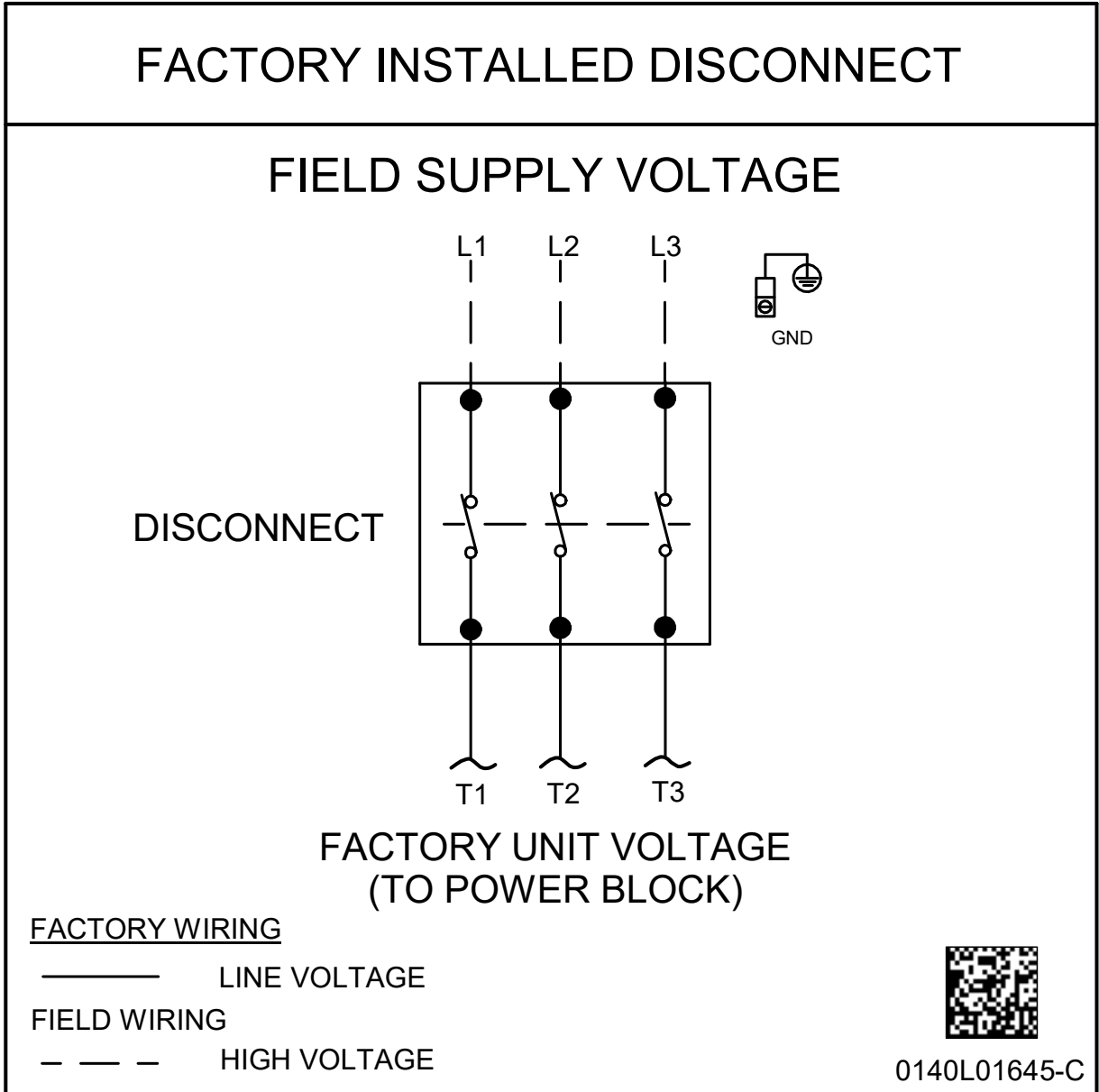

Wiring is subject to change. Always refer to the wiring diagram on the unit for the most up-to-date wiring.

CUSTOMER FEEDBACK

Daikin is very interested in all product comments.

Please fill out the feedback form on the following link:

<https://daikincomfort.com/contact-us>

You can also scan the QR code on the right to be directed to the feedback page.



NOTE: SPECIFICATIONS AND PERFORMANCE DATA LISTED HEREIN ARE SUBJECT TO CHANGE WITHOUT NOTICE

Quality Makes the Difference!

All of our systems are designed and manufactured with the same high quality standards regardless of size or efficiency. We have designed these units to significantly reduce the most frequent causes of product failure. They are simple to service and forgiving to operate. We use quality materials and components. Finally, every unit is run tested before it leaves the factory. That's why we know. . . **There's No Better Quality.**

Visit our website at www.daikinac.com for information on:

- Products
- Warranties
- Customer Services
- Parts
- Contractor Programs and Training
- Financing Options

© 2013, 2019 **DAIKIN MANUFACTURING COMPANY, L.P**

HINGED DOOR, 7.5-12.5 TON

Factory installed hinged door option for 7.5-12.5 ton light commercial models

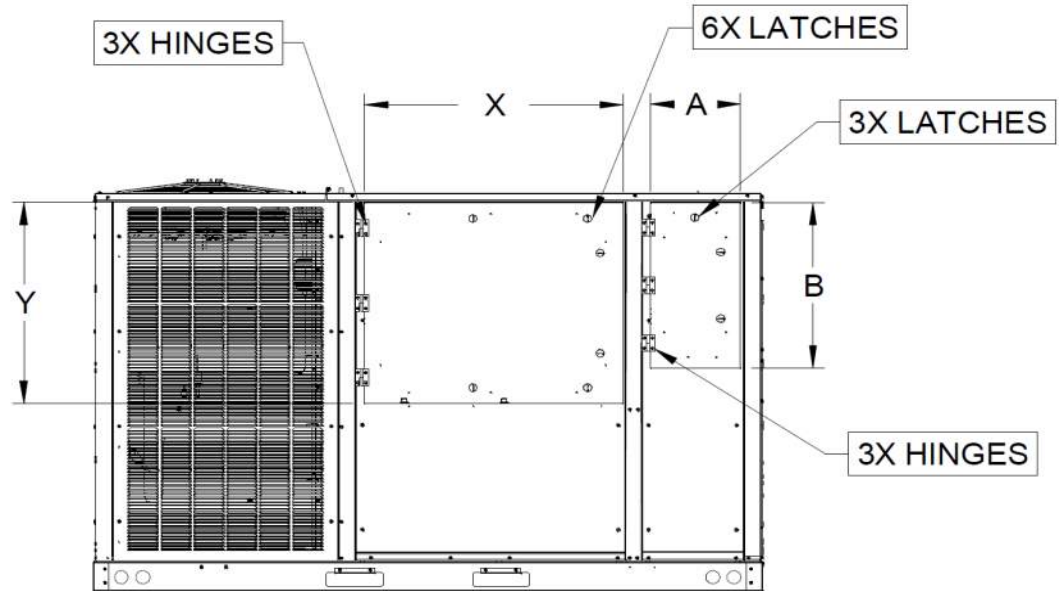

➤ Hinged door size:

- 7.5/8.5/10Ton: A= 12.62, B= 24.46, X= 36.27, Y= 25.65
 - 12.5Ton: A= 12.62, B= 24.46, X= 36.27, Y= 29.63
- (All dimensions in inches)

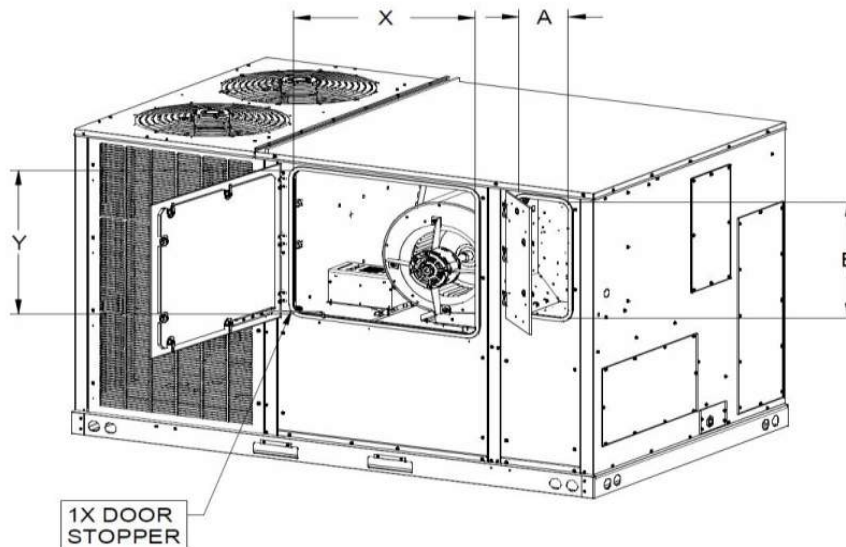

➤ Blower and control box opening:

- 7.5/8.5/10Ton: A= 9.42, B= 22.40, X= 32.61, Y= 23.31
 - 12.5Ton: A= 9.42, B= 22.40, X= 32.61, Y= 27.49
- (All dimensions in inches)



Modulating Hot Gas Reheat Dehumidification Air System

High indoor humidity levels can create uncomfortable experiences for customers, tenants, and occupants. Adding additional dehumidification capability to a standard rooftop can help control humidity levels for high humidity climates. With the Daikin Modulating Hot Gas Reheat Dehumidification Air System, the perfect indoor air is possible!



How it Works:

Using a space temperature and humidity sensor in conjunction with the Daikin *iLINO* Controller and Reheat Module, the unit can initiate a Dehumidification Mode as the space humidity rises above set-point. In this mode, the modulating valve diverts a percentage of the hot gas to the reheat coil as required to maintain supply air temperature requirements while lowering the space relative humidity. The modulating valve system allows smooth transition into dehumidification and longer run time at a steady supply air temperature. The indoor fan will operate at low speed during dehumidification mode. The 2 modes of operation are:

Normal Cooling

Heat Gas Valve (HGV) closed, Purge Valve open

In cooling mode, the unit can operate with one or two compressor stages. The cooling only system operation is the same as a typical refrigerant cycle.

Dehumidification

Heat Gas Valve (HGV) open, Purge Valve closed

If the space temperature is satisfied, but the space humidity is high, the unit will initiate Dehumidification Mode. One or two compressor stages, as allowed by the system, will stage on. The supply air will be regulated at a neutral temperature setting by modulating the HGV to extend operation of the evaporator coils for dehumidification. As space conditions change, the supply air temperature set-point is reset to maintain occupant comfort and optimize compressor operation.

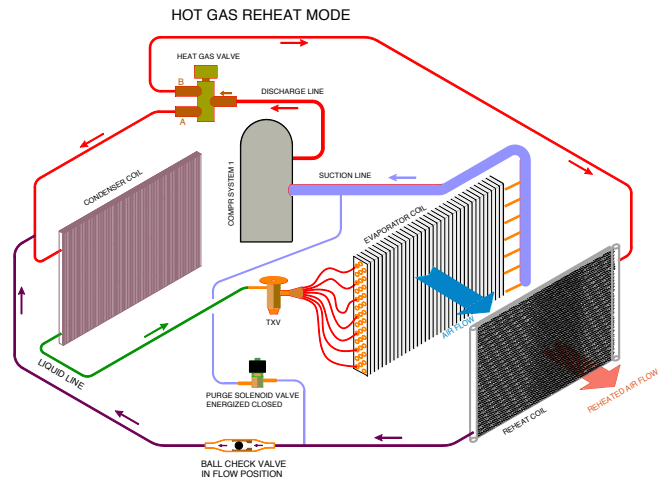
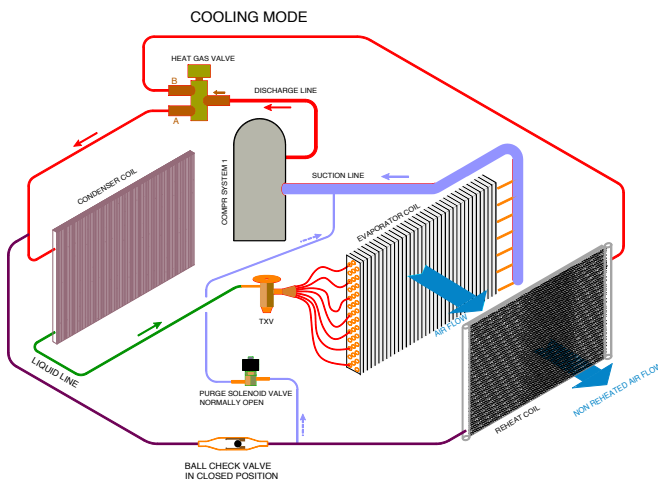

AN IDEAL SOLUTION FOR EVERY APPLICATION:

Schools/Educational Buildings • Restaurant and Shopping Centers • Hospitals and Care Centers
Fitness and Industrial Facilities • Museums, Galleries, and more!

Learn more at www.daikinac.com



Our continuing commitment to quality products may mean a change in specifications without notice.

TTBCKHE01 & TTBCKHE02 THRU-THE-BOTTOM SERVICE CONNECTION KIT (FOR 3-12.5 TON) LIGHT COMMERCIAL GAS UNITS INSTALLATION INSTRUCTIONS



© 2019 **DAIKIN MANUFACTURING COMPANY, L.P.**
19001 Kermier Rd. Waller, TX 77484
www.daikincomfort.com
P/N: IOD-7118 Date: October 2019

Safety Considerations

The following symbols and labels are used throughout this manual to indicate immediate or potential safety hazards. It is the owner's and installer's responsibility to read and comply with all safety information and instructions accompanying these symbols. Failure to heed safety information increases the risk of personal injury, property damage, and/or product damage.

 WARNING
ONLY PERSONNEL THAT HAVE BEEN TRAINED TO INSTALL, ADJUST, SERVICE OR REPAIR (HEREINAFTER, "SERVICE") THE EQUIPMENT SPECIFIED IN THIS MANUAL SHOULD SERVICE THE EQUIPMENT. THE MANUFACTURER WILL NOT BE RESPONSIBLE FOR ANY INJURY OR PROPERTY DAMAGE ARISING FROM IMPROPER SERVICE OR SERVICE PROCEDURES. IF YOU SERVICE THIS UNIT, YOU ASSUME RESPONSIBILITY FOR ANY INJURY OR PROPERTY DAMAGE WHICH MAY RESULT. IN ADDITION, IN JURISDICTIONS THAT REQUIRE ONE OR MORE LICENSES TO SERVICE THE EQUIPMENT SPECIFIED IN THIS MANUAL, ONLY LICENSED PERSONNEL SHOULD SERVICE THE EQUIPMENT. IMPROPER INSTALLATION, ADJUSTMENT, SERVICING OR REPAIR OF THE EQUIPMENT SPECIFIED IN THIS MANUAL, OR ATTEMPTING TO INSTALL, ADJUST, SERVICE OR REPAIR THE EQUIPMENT SPECIFIED IN THIS MANUAL WITHOUT PROPER TRAINING MAY RESULT IN PRODUCT DAMAGE, PROPERTY DAMAGE, PERSONAL INJURY OR DEATH.

PROP 65 WARNING FOR CALIFORNIA CONSUMERS
 WARNING
Cancer and Reproductive Harm - www.P65Warnings.ca.gov
<small>0140M00517-A</small>

 WARNING
HIGH VOLTAGE!
DISCONNECT ALL POWER BEFORE SERVICING OR INSTALLING THIS UNIT. MULTIPLE POWER SOURCES MAY BE PRESENT. FAILURE TO DO SO MAY CAUSE PROPERTY DAMAGE, PERSONAL INJURY OR DEATH.

ATTENTION INSTALLING PERSONNEL

As a professional installer, you have an obligation to know the product better than the customer. This includes all safety precautions and related items.

Prior to actual installation, thoroughly familiarize yourself with this Instruction Manual. Pay special attention to all safety warnings. Often during installation or repair, it is possible to place yourself in a position which is more hazardous than when the unit is in operation.

Remember, it is your responsibility to install the product safely and to know it well enough to be able to instruct a customer in its safe use.

Safety is a matter of common sense...a matter of thinking before acting. Most dealers have a list of specific good safety practices...follow them.

The precautions listed in this Installation Manual are intended as supplemental to existing practices. However, if there is a direct conflict between existing practices and the content of this manual, the precautions listed here take precedence.

	PART NO.	DESCRIPTION	QTY
TTBCKHE01	0163L00152	½" Gas Adapter Fitting	1
	0163L00154	½" Elec. Bulkhead Connector	2
	0163L00196	1-½" Elec. Bulkhead Connector	1
	0121L02301	Bracket Thru the Base	1
	B1910010	Gas Line Grommet	1
	B1393561	#10 x ½" Self-Drilling Screw	2
TTBCKHE02	0163L00154	½" Elec. Bulkhead Connector	2
	0163L00197	2" Elec. Bulkhead Connector	1
	0121L02876	Bracket Thru the Base	1
	B1393561	#10 x ½" Self-Drilling Screw	2

Table 1 - Thru-the-Bottom Connection Parts

DESCRIPTION

Thru-the-bottom service connection kits reduce the number of penetrations in the roof. They provide a watertight way to connect power wiring, control wiring, and the gas supply line through the base of the unit in the condenser section. External connectors must be weatherproof. All holes in the unit base must be sealed (including those around conduit nuts) to prevent water leakage into the building.

When the thru-the-bottom power accessory package is purchased, one of two bulkhead connector sets may be selected for power connections (depending on unit size). Each set contains 3 to 4 bulkhead connectors, depending on unit tonnage (Table 1). The ½ in. diameter bulkhead connectors enable the low-voltage control, and optional convenience outlet, wires to pass through the basepan. The 1-½ or 2 in. bulkhead connector allows the high voltage power wires to pass through the basepan. The ½ in. gas adapter fitting allows the gas line to come up through the basepan (3 to 6 ton units only).



INSTALLATION

Disconnect all power before installing this kit.

Make sure the roof curb is installed and leveled in accordance with the instructions provided with kit.

The thru-the-bottom service connection accessory package must be used with a light commercial unit that has embossment in the outdoor section of the basepan. This opening allows high-voltage power, control wiring, and gas connections to pass through the roof curb and into the basepan of the rooftop unit.

PREPARING THE UNIT FOR INSTALLATION

The accessory thru-the-bottom power or gas connection package fittings must be installed before the unit is set on the roof curb. Gas and electrical connections to the unit must be field installed after the unit is installed on the roof curb.

INSTALL THE UNIT ON THE ROOF CURB

Follow all appropriate instructions required to install the rooftop unit on the roof curb. See installation instructions provided with the roof curb and unit for more specific information.

CREATING HOLES IN THE RAISED SURFACE OF THE UNIT BASEPAN

Each unit is equipped with a raised (embossed) surface in the basepan. This area is located in the compressor compartment (outdoor section) of the unit (see Figure 1). The embossment of the basepan contains three (3) dimples for locating cutouts. Holes can be field cut in the embossed surface so that high voltage power, control wires, and gas connection can be routed through the roof curb basepan

Drill holes for gas and power at the 3 dimples shown below.

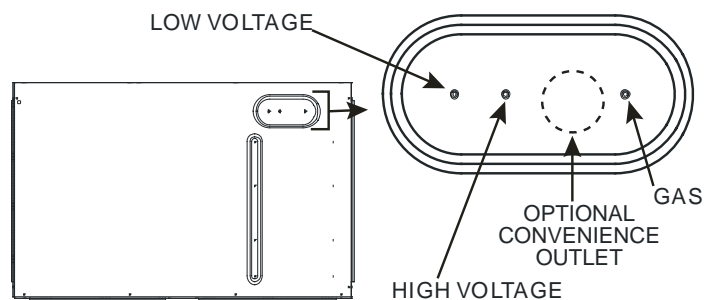

Fig. 1 - 3 - 6 Ton Basepan

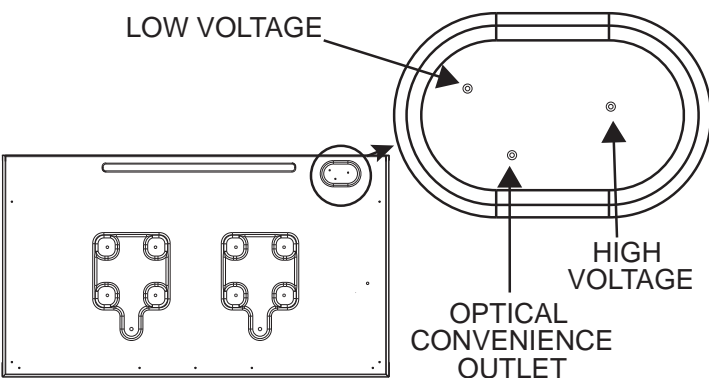

Fig. 2 - 7.5 - 12.5 Ton Basepan

Use a chassis punch or hole saw to create holes in the embossed surface of the basepan per Table 2.

CONNECTION SIZE	USE	REQ. HOLE SIZE
1/2"	Low Voltage	7/8"
1/2"	Gas	1"
3/4"	Gas	1-1/8"
1-1/2"	High Voltage	2"
2"	High Voltage	2-1/2"

Table 2 - Bottom Power Chart

MOUNTING ELECTRIC BULKHEAD CONNECTORS

Once the holes have been cut place electrical bulkhead connectors in basepan. Place gasket and lock ring end of connector beneath the basepan and mount the other end above the basepan.

When the electrical connectors are in place, field supplied and installed liquid tight conduit connectors and conduit may be attached to the connectors. Pull correctly rated high voltage and low voltage wires through appropriate conduits and connect to units per roof top units installation instructions.

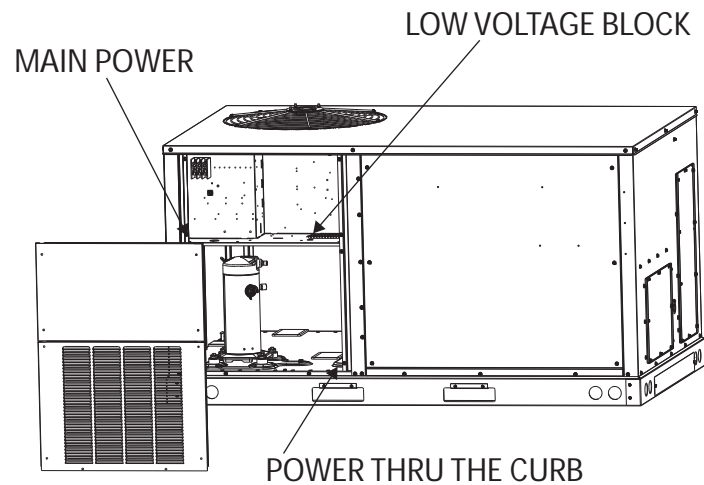

Fig. 3 - 3-6 Ton Power Connections

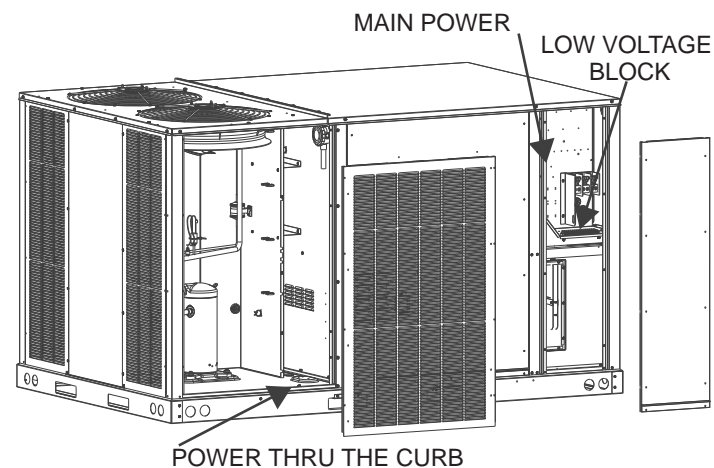

Fig. 4 - 7.5 - 12.5 Ton Power Connections

MAKING GAS CONNECTIONS (3 TO 6 TON UNITS ONLY)

The thru-the-bottom gas connection fitting has male and female threads. The gas fitting also contains two neoprene washers and two locking washers. One neoprene and one locking washer are installed below the unit basepan with the second set being installed on the top side of the basepan before the fitting is tightened. Tighten all fittings. The male threads protrude above the basepan of the unit, while the female threads protrude below the basepan.

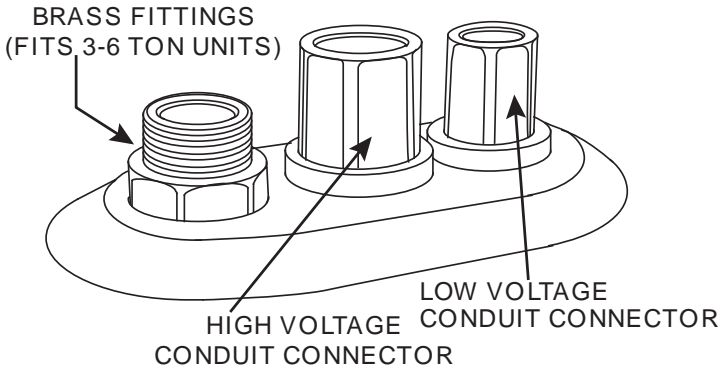

Fig. 5

Install a 5" black pipe nipple and an elbow on the through-the-basepan gas fitting (1/2-in. for 3-6 Ton kit).

If using 1/2-in. pipe, a minimum 12-in. nipple (field-supplied) is required to attach to the elbow and extends the gas piping through compressor access panel (if unit is so equipped). If using 3/4-in. pipe, a minimum 15-in. nipple (field-supplied) is required to extend the gas piping through compressor access panel (if unit is so equipped). Install the gas pipe support bracket to the inside of unit using provided screws. Remove the bottom right ten louvers from the right side of the louvered compressor access panel to allow gas line to exit the unit.



Fig. 6



Fig. 7



Fig. 8

INSTALLING GAS PIPING (3 TO 6 TON UNITS ONLY)

The rating plate is stamped with the model number, type of gas and gas input rating. Make sure the unit is equipped to operate on the type of gas available. Conversion to propane (LP) gas is permitted with the use of the factory authorized conversion kit (see the unit Technical Manual for the appropriate kit). For High Altitude derates, refer to the latest edition of the National Fuel Gas Code NFPA 54/ANSI Z223.1.

A manual gas shut off valve must be field installed external to the roof top unit. In addition, a drip leg must be installed near the inlet connection. A ground joint union connection is required between the external shut off valve and the unit connection to the gas valve to permit removal of the burner assembly for servicing.

NOTE: Inlet gas pressures must not exceed the maximum value shown in Table 3 below.

INLET GAS PRESSURE	
NATURAL	Min. 5.0" W.C., Max. 10.0" W.C.
PROPANE	Min. 11.0" W.C., Max. 14.0" W.C.

Table 3 - Inlet Gas Pressure

CUSTOMER FEEDBACK

Daikin is very interested in all product comments.

Please fill out the feedback form on the following link:

<https://daikincomfort.com/contact-us>

You can also scan the QR code on the right to be directed to the feedback page.



NOTE: SPECIFICATIONS AND PERFORMANCE DATA LISTED HEREIN ARE SUBJECT TO CHANGE WITHOUT NOTICE

© 2019 **DAIKIN MANUFACTURING COMPANY, L.P.**
www.daikincomfort.com

DAIKIN**COMMERCIAL WARRANTY****Models: DRC, DRG, DRH, DHC, DHG, DHH**Who Is Providing The Warranty?

This warranty is provided to you by Daikin Comfort Technologies Manufacturing, L.P. ("Daikin"), which warrants all parts of this heating or air conditioning unit, as described below.

To What Type Of Installations Does This Warranty Apply?

This warranty applies to heating and air conditioning units installed in buildings other than residences.

What Units Does This Warranty Not Cover?

This warranty does not apply to:

- Units that are ordered over the Internet, by telephone, or by other electronic means unless the unit is installed by a dealer adhering to all applicable federal, state, and local codes, policies, and licensing requirements.
- Units that are installed outside the United States, its territories, or Canada.
- Units that are operated in incomplete structures.
- Units that are installed in residential buildings.

What Problems Does This Warranty Cover?

This warranty covers defects in materials and workmanship that appear under normal use and maintenance.

Other Warranties

THIS WARRANTY IS PROVIDED IN LIEU OF ANY OTHER WARRANTIES, WHETHER BY DAIKIN OR ANY OF ITS AFFILIATES, EXPRESS OR IMPLIED, INCLUDING ANY IMPLIED WARRANTY OF MERCHANTABILITY OR FITNESS FOR A PARTICULAR PURPOSE.

What Problems Does This Warranty Not Cover?

Daikin is not responsible for:

- Damage or repairs required as a consequence of faulty installation or application.
- Damage as a result of floods, fires, winds, lightning, natural disasters, accidents, corrosive atmosphere, or other conditions beyond Daikin's control.
- Damage or the need for repairs arising from the use of components or accessories not compatible with this unit.
- Normal maintenance as described in the installation and operating manual, such as cleaning of the coils, filter cleaning and/or replacement, and lubrication.
- Parts or accessories not supplied or designated by the manufacturer.

- Damage or the need for repairs resulting from any improper use, maintenance, operation, or servicing.
- Damage or failure of the unit to start due to interruption, surge, or fluctuation in electrical service or inadequate electrical service.
- Any damage, or the need for any repairs, caused by frozen or broken water pipes, water damage, moisture intrusion, mold or other biological growth. Changes in the appearance of the unit that do not affect its performance.
- Replacement of fuses and replacement or resetting of circuit breakers.
- Damage or the need for repairs resulting from the use of unapproved refrigerant types or used or recycled refrigerant.

When Does Warranty Coverage Begin?

Warranty coverage begins on the "installation date." The installation date is one of two dates:

- (1) The installation date is the date that the unit is originally installed.
- (2) If the date the unit is originally installed cannot be verified, the installation date is three months after the manufacture date. The first four digits of the serial number (YYMM) on the unit indicate the manufacture date. For example, a serial number beginning with "2409" indicates the unit was manufactured in September 2024.

How Long Does Warranty Coverage Last?

The warranty lasts for a period of up to (1) 20 YEARS after the installation date for the heat exchanger (only applicable to units containing a heat exchanger) and (2) 5 YEARS after the installation date on all other parts.

This warranty period does not continue after the unit is removed from the location where it was originally installed.

The replacement of a part under this warranty does not extend the warranty period. In other words, Daikin warrants a replacement part only for the period remaining under the applicable warranty on the original part.

www.daikincomfort.com

For further information about this warranty, contact Homeowner Support by mail to 19001 Kermier Road, Waller, Texas 77484

Part No. PWDLCPPHED
09/2024

DAIKIN**COMMERCIAL WARRANTY****Models: DRC, DRG, DRH, DHC, DHG, DHH**What Will Daikin Do To Correct Problems?

Daikin will furnish a replacement part, without charge for the part only, to replace any part that is found to be defective due to workmanship or materials under normal use and maintenance during the warranty period. Furnishing of the replacement part is Daikin's only responsibility under this warranty.

THE REMEDIES DESCRIBED IN THIS SECTION ARE DAIKIN'S ONLY RESPONSIBILITIES, AND THE OWNER'S ONLY REMEDIES, FOR ANY BREACH OF ANY WARRANTY.

What Won't Daikin Do To Correct Problems?

Daikin will not pay for:

- Labor, freight, or any other cost associated with the service, repair, or operation of the unit, the deinstallation of any defective part, or the installation of any replacement part.
- Electricity or fuel costs, or increases in electricity or fuel costs, for any reason, including additional or unusual use of supplemental electric heat.
- Lodging or transportation charges.
- Refrigerant.

WHETHER ANY CLAIM IS BASED ON NEGLIGENCE OR OTHER TORT, BREACH OF WARRANTY OR OTHER BREACH OF CONTRACT, OR ANY OTHER THEORY, NEITHER DAIKIN NOR ANY OF ITS AFFILIATES SHALL IN ANY EVENT BE LIABLE FOR INCIDENTAL OR CONSEQUENTIAL DAMAGES, INCLUDING BUT NOT LIMITED TO LOST PROFITS, LOSS OF USE OF A UNIT, EXTRA UTILITY EXPENSES, OR DAMAGES TO PROPERTY.

How Can The Owner Receive Warranty Service?

If there is a problem with the unit, contact a licensed contractor.

To receive a replacement part, a licensed contractor must bring the defective part to a Daikin heating and air conditioning products distributor.

For more information about the warranty, write to Homeowner Support, 19001 Kermier Road, Waller, Texas 77484.

Where Can Any Legal Remedies Be Pursued?

ARBITRATION CLAUSE. IMPORTANT. PLEASE REVIEW THIS ARBITRATION CLAUSE. IT AFFECTS YOUR LEGAL RIGHTS.

1. *Parties*: This arbitration clause affects your rights against Daikin Comfort Technologies North America, Inc. and any of its subsidiaries, including but not limited to Daikin Comfort Technologies Manufacturing, L.P., and its or their employees or agents, successors, or assigns, all of whom together are referred to below as "we" or "us" for ease of reference.

2. **ARBITRATION REQUIREMENT: EXCEPT AS STATED BELOW, ANY DISPUTE BETWEEN YOU AND ANY OF US SHALL BE DECIDED BY NEUTRAL, BINDING ARBITRATION RATHER THAN IN COURT OR BY JURY TRIAL.** "Dispute" will be given the broadest possible meaning allowable by law. It includes any dispute, claim, or controversy arising from or relating to your purchase of this heating or air conditioning unit, any warranty upon the unit, or the unit's condition. It also includes determination of the scope or applicability of this Arbitration Clause. The arbitration requirement applies to claims in contract and tort, pursuant to statute, or otherwise.
3. **CLASS-ARBITRATION WAIVER: ARBITRATION IS HANDLED ON AN INDIVIDUAL BASIS. IF A DISPUTE IS ARBITRATED, YOU AND WE EXPRESSLY WAIVE ANY RIGHT TO PARTICIPATE AS A CLASS REPRESENTATIVE OR CLASS MEMBER ON ANY CLASS CLAIM YOU MAY HAVE AGAINST US OR WE AGAINST YOU, OR AS A PRIVATE ATTORNEY GENERAL OR IN ANY OTHER REPRESENTATIVE CAPACITY, TO THE MAXIMUM EXTENT PERMITTED BY LAW. YOU AND WE ALSO WAIVE ANY RIGHT TO PARTICIPATE IN ANY CLASS OR REPRESENTATIVE ACTION IN ANY FORM, INCLUDING ANY CLASS ARBITRATION, OR ANY CONSOLIDATION OF INDIVIDUAL ARBITRATIONS.**
4. *Discovery and Other Rights*: Discovery and rights to appeal in arbitration are generally more limited than in a lawsuit. This applies to both you and us. Other rights that you or we would have in court may not be available in arbitration. Please read this Arbitration Clause and consult the rules of the arbitration organizations listed below for more information.
5. **SMALL CLAIMS COURT OPTION: YOU MAY CHOOSE TO LITIGATE ANY DISPUTE BETWEEN YOU AND ANY OF US IN SMALL CLAIMS COURT, RATHER THAN IN ARBITRATION, IF THE DISPUTE MEETS ALL REQUIREMENTS TO BE HEARD IN SMALL CLAIMS COURT.**
6. *Governing Law*: For residents of the United States, the procedures and effect of the arbitration will be governed by the Federal Arbitration Act (9 U.S.C. § 1 et seq.) rather than by state law concerning arbitration. For residents of Canada, the procedures and effect of the arbitration will be governed by the applicable arbitration law of the province in which you purchased your unit. The law governing your substantive warranty rights and other claims will be the law of the state or province in which your unit was installed. Any court having jurisdiction may enter judgment on the arbitration award.

Part No. PWDLCPPHED
09/2024

DAIKIN**COMMERCIAL WARRANTY****Models: DRC, DRG, DRH, DHC, DHG, DHH**

7. *Rules of the Arbitration:* If the amount in controversy is less than \$250,000, the arbitration will be decided by a single arbitrator. If the amount in controversy is greater than or equal to \$250,000, the arbitration will be decided by a panel of three arbitrators. The arbitrator(s) will be chosen pursuant to the rules of the administering arbitration organization. United States residents may choose JAMS (1920 Main Street, Ste. 300, Irvine, CA 92614, www.jamsadr.com) or, subject to our approval, any other arbitration organization. In addition, Canadian residents may choose the ADR Institute of Canada (234 Eglinton Ave. East, Suite 405, Toronto, Ontario, M4P 1K5, www.amic.org). These organizations' rules can be obtained by contacting the organization or visiting its website. If the chosen arbitration organization's rules conflict with this Arbitration Clause, the provisions of this Arbitration Clause control. The award of the arbitrator(s) shall be final and binding on all parties.
8. *Location of the Arbitration Hearing:* Unless applicable law provides otherwise, the arbitration hearing for United States residents will be conducted in the federal judicial district in which you reside (in your hometown area) or, for Canadian residents, in the province in which you reside, and if you choose, will be in person.
9. *Costs of the Arbitration:* Each party is responsible for its own attorney, expert, and other costs and fees unless applicable law requires otherwise. Each party is also responsible for one-half of any cost and fees charged by the arbitration organization and arbitrator(s) to administer the arbitration to the maximum extent permitted by law or rule. Where permissible by law, the prevailing party may be required to reimburse the other party for the costs and fees of the arbitration organization and arbitrator(s) in whole or in part by decision of the arbitrator(s) at the discretion of the arbitrator(s).
10. *Survival and Enforceability of this Arbitration Clause:* This Arbitration Clause shall survive the expiration or termination, or any transfer, of the warranty on your unit. If any part of this Arbitration Clause, except waivers of class-action rights, is found to be unenforceable for any reason, the remainder of this clause and the warranty shall remain enforceable. If, in a case in which class-action allegations have been made, the waiver of class-action rights under this warranty is found to be unenforceable with respect to any part of the dispute, the parts of the dispute as to which the waiver of class-action rights have been found unenforceable will be severed and will proceed in court without reference or application of this Arbitration Clause. Any remaining parts will proceed in arbitration.

Part No. PWDLCPPHED
09/2024