



# Submittal

*PROPRIETARY AND CONFIDENTIAL PROPERTY OF Trane U.S. Inc. dba Trane  
DISTRIBUTION TO OTHER THAN THE NAMED RECIPIENT IS PROHIBITED*

*© 2021 Trane Technologies All rights reserved*

**Prepared For:**  
VMI

**Date:** November 11, 2021

**Customer P.O. Number:**  
**Customer Project Number:**

**Sold To:**

**Job Number:**  
**Job Name:**  
IBP XVIII Plano

---

Trane U.S. Inc. dba Trane is pleased to provide the enclosed submittal for your review and approval.

## Product Summary

Qty	Product
10	Commercial Rooftop Air Conditioning Units (Midrange)

---

**Ryan G Smith**  
Trane U.S. Inc. dba Trane  
1617 HUTTON DRIVE  
Carrollton, TX 75006-8336  
Cell: (214) 621-0406

*The attached information describes the equipment we propose to furnish for this project, and is submitted for your approval.*

*Product performance and submittal data is valid for a period of 6 months from the date of submittal generation. If six months or more has elapsed between submittal generation and equipment release, the product performance and submittal data will need to be verified. It is the customer's responsibility to obtain such verification.*

## NOTES

Changed SCCR rating to 65,000  
Change curb drawing to correct unit (last page)

## Table Of Contents

<b>Product Summary</b> .....	<b>1</b>
<b>Commercial Rooftop Air Conditioning Units (Midrange) (Items A1 - A10)</b>	
Tag Data .....	3
Product Data .....	3
Performance Data .....	5
Mechanical Specifications .....	8
Unit Dimensions .....	12
Fan Curve .....	26
Weight, Clearance & Rigging Diagram.....	36
Accessory .....	41

**Tag Data - Commercial Rooftop Air Conditioning Units (Midrange) (Qty: 10)**

Item	Tag(s)	Qty	Description	Model Number
A1	RTU-1N	1	60 Ton Packaged Industrial Rooftop	SAHLF6040-
A2	RTU-1S	1	70 Ton Packaged Industrial Rooftop	SXHLF7040-
A3	RTU-2N	1	70 Ton Packaged Industrial Rooftop	SAHLF7040-
A4	RTU-2S	1	70 Ton Packaged Industrial Rooftop	SAHLF7040-
A5	RTU-3N	1	70 Ton Packaged Industrial Rooftop	SAHLF7040-
A6	RTU-3S	1	70 Ton Packaged Industrial Rooftop	SAHLF7040-
A7	RTU-4N	1	70 Ton Packaged Industrial Rooftop	SAHLF7040-
A8	RTU-4S	1	70 Ton Packaged Industrial Rooftop	SAHLF7040-
A9	RTU-5N	1	75 Ton Packaged Industrial Rooftop	SAHLF7540-
A10	RTU-5S	1	75 Ton Packaged Industrial Rooftop	SAHLF7540-

**Product Data - Commercial Rooftop Air Conditioning Units (Midrange)**

**All Units**

- R-410A refrigerant
- 460 Volt-60 Hertz-3 Phase
- 0-100% Economizer
- Economizer control w/ comparative enthalpy
- Grease lines
- 2.00" [51mm] Spring isolators
- MERV 8 High efficiency throwaway filters
- eDrive, Direct drive plenum (DDP) supply fan
- VAV (DTC) with supply & exhaust/return VFD
- cULus
- Non-fused unit disconnect switch
- Low leak outside air dampers
- eFlex Variable speed compressor
- Hinged access doors
- BACnet communication interface module
- Factory-powered 15A GFI Convenience outlet
- 2nd-5th Year Replacement Compressor Warranty

**Item: A1 Qty: 1 Tag(s): RTU-1N**

- DX Cooling only
- 60 Ton unit
- 100% Return 7.5 hp with Statitrac building pressure control
- 700 rpm - Exhaust/return fan
- 15 hp DDP 120% width
- 1500 rpm

**Item: A2 Qty: 1 Tag(s): RTU-1S**

- DX Cooling only with extended casing
- 70 Ton unit
- 100% Return 7.5 hp with Statitrac building pressure control
- 800 rpm - Exhaust/return fan
- 20 hp DDP 120% width
- 1300 rpm

**Item: A3 Qty: 1 Tag(s): RTU-2N**

- DX Cooling only
- 70 Ton unit
- 100% Exhaust - 5 hp with Statitrac building pressure control
- 500 rpm - Exhaust/return fan
- 30 hp DDP 80% width
- 1800 rpm

**Item: A4 Qty: 1 Tag(s): RTU-2S**

- DX Cooling only
- 70 Ton unit
- 100% Exhaust - 5 hp with Statitrac building pressure control

500 rpm - Exhaust/return fan

30 hp DDP 80% width

1700 rpm

**Item: A5, A6, A7, A8 Qty: 4 Tag(s): RTU-3N, RTU-3S, RTU-4N, RTU-4S**

DX Cooling only

70 Ton unit

100% Exhaust - 5 hp with Statitrac building pressure control

500 rpm - Exhaust/return fan

20 hp DDP 120% width

1400 rpm

**Item: A9, A10 Qty: 2 Tag(s): RTU-5N, RTU-5S**

DX Cooling only

75 Ton unit

100% Exhaust - 5 hp with Statitrac building pressure control

500 rpm - Exhaust/return fan

30 hp DDP 120% width

1600 rpm

**Performance Data - Commercial Rooftop Air Conditioning Units (Midrange)**

Tags	RTU-1N	RTU-1S	RTU-2N	RTU-2S	RTU-3N	RTU-3S
Supply airflow (cfm)	18235	20585	22405	22115	21325	21115
Exhaust/Return airflow (cfm)	16000	18000	17000	17000	18000	18000
Elevation (ft)	0.00	0.00	0.00	0.00	0.00	0.00
Cooling entering DB (F)	79.90	79.10	79.20	79.00	79.30	79.30
Cooling entering WB (F)	62.60	62.20	62.30	62.10	62.30	62.30
Ambient DB (F)	102.00	102.00	102.00	102.00	102.00	102.00
leaving coil DB (F)	50.79	49.83	51.24	50.86	50.57	51.15
leaving coil WB (F)	49.62	49.07	50.05	49.71	49.58	49.96
total capacity (MBh)	665.20	762.14	778.28	773.71	770.72	777.35
sensible capacity (MBh)	592.06	694.98	719.53	714.94	708.00	718.81
latent capacity (MBh)	73.14	67.16	58.76	58.77	62.72	58.54
Fan motor heat (MBh)	34.82	41.11	57.85	56.41	47.82	50.77
Evaporator face area (sq ft)	43.00	43.00	43.00	43.00	43.00	43.00
Supply duct static pressure (in H2O)	1.5	1.5	1.5	1.5	1.5	1.5
Return duct static pressure (in H2O)	0.500	0.500	0.400	0.400	0.300	0.300
Component S.P. drop (in H2O)	0.902	1.118	1.286	1.260	1.196	1.270
Total static pressure (in H2O)	3.402	3.618	3.686	3.660	3.496	3.570
Supply motor bhp (bhp)	12.73	15.03	21.15	20.62	17.48	18.56
Supply fan rpm (rpm)	1453	1299	1702	1685	1366	1396
Supply fan efficiency (%)	64.42	66.96	61.16	61.47	67.10	66.94
Exhaust static pressure (in H2O)	1.060	1.220	0.400	0.400	0.300	0.300
Return damper drop (in H2O)	0.560	0.720	-	-	-	-
Exhaust motor bhp (bhp)	4.23	5.63	3.95	3.95	4.44	4.44
Exhaust fan rpm (rpm)	693	766	482	482	487	487
System power (kW)	73.89	85.79	90.73	90.27	87.73	88.64
EER @ AHRI (EER)	10.5	10.1	10.1	10.1	10.1	10.1
IEER @ AHRI (EER)	16.6	16.9	16.9	16.9	16.9	16.9
Minimum circuit ampacity (A)	139.93	162.43	166.63	166.63	159.23	159.23
Maximum overcurrent protection (A)	175.00	200.00	200.00	200.00	175.00	175.00
Minimum disconnect switch size (A)	149.00	175.00	180.00	180.00	171.00	171.00
Recommended dual element (A)	150.00	175.00	200.00	200.00	175.00	175.00
Compressor 1 count (Each)	1.00	1.00	1.00	1.00	1.00	1.00
Compressor 1 RLA (A)	22.20	25.40	25.40	25.40	25.40	25.40
Compressor 2 count (Each)	1.00	1.00	1.00	1.00	1.00	1.00
Compressor 2 RLA (A)	25.50	37.20	37.20	37.20	37.20	37.20
Compressor 3 count (Each)	1.00	1.00	1.00	1.00	1.00	1.00
Compressor 3 RLA (A)	38.90	38.90	38.90	38.90	38.90	38.90
Supply fan motor FLA (A)	11.00	14.30	18.00	18.00	14.30	14.30
Supply motor count ( )	2	2	2	2	2	2
Supply fan count (Each)	2.00	2.00	2.00	2.00	2.00	2.00
Condenser fan FLA (A)	10.80	10.80	10.80	10.80	10.80	10.80
Exhaust fan motor FLA (A)	9.80	9.80	6.60	6.60	6.60	6.60
Other FLA (A)	1.00	2.00	2.00	2.00	2.00	2.00
R-410A refrigerant charge - circuit 1 (lb)	41.8	42.3	41.8	41.8	41.8	41.8
R-410A refrigerant charge - circuit 2 (lb)	40.0	45.0	45.0	45.0	45.0	45.0
Installed point load 1 (lb)	1109.8	880.3	1085.6	1085.6	1085.6	1085.6
Installed point load 2 (lb)	1178.6	992.1	1180.5	1180.5	1180.5	1180.5
Installed point load 3 (lb)	1206.2	980.1	1217.6	1217.6	1217.6	1217.6
Installed point load 4 (lb)	1275.0	1092.0	1312.5	1312.5	1312.5	1312.5
Installed point load 5 (lb)	1302.6	1068.7	1349.6	1349.6	1349.6	1349.6
Installed point load 6 (lb)	1371.4	1180.5	1444.5	1444.5	1444.5	1444.5
Installed point load 7 (lb)	1382.3	1158.2	1458.8	1458.8	1458.8	1458.8
Installed point load 8 (lb)	1451.1	1270.0	1553.7	1553.7	1553.7	1553.7
Installed point load 9 (lb)	-	1257.0	-	-	-	-
Installed point load 10 (lb)	-	1368.8	-	-	-	-

Tags	RTU-1N	RTU-1S	RTU-2N	RTU-2S	RTU-3N	RTU-3S
Total installed weight (lb)	10277.0	11247.8	10602.8	10602.8	10602.8	10602.8
First X dimension (ft)	15.23	16.85	15.50	15.50	15.50	15.50
First Y dimension (ft)	4.95	5.06	4.99	4.99	4.99	4.99
Installed point load 1 - X (in)	4.000	4.000	4.000	4.000	4.000	4.000
Installed point load 1 - Y (in)	4.000	4.000	4.000	4.000	4.000	4.000
Installed point load 2 - X (in)	120.000	101.000	120.000	120.000	120.000	120.000
Installed point load 2 - Y (in)	112.000	112.000	112.000	112.000	112.000	112.000
Installed point load 3 - X (in)	236.000	187.000	236.000	236.000	236.000	236.000
Installed point load 4 - X (in)	332.000	274.000	332.000	332.000	332.000	332.000

Tags	RTU-4N	RTU-4S	RTU-5N	RTU-5S
Supply airflow (cfm)	21050	22180	26860	26605
Exhaust/Return airflow (cfm)	18000	18000	18000	18000
Elevation (ft)	0.00	0.00	0.00	0.00
Cooling entering DB (F)	79.20	79.30	79.50	79.20
Cooling entering WB (F)	62.30	62.30	62.10	61.90
Ambient DB (F)	102.00	102.00	102.00	102.00
leaving coil DB (F)	50.33	51.20	52.30	51.94
leaving coil WB (F)	49.46	49.99	50.80	50.51
total capacity (MBh)	767.84	777.87	867.40	862.84
sensible capacity (MBh)	702.64	719.68	846.72	840.65
latent capacity (MBh)	65.20	58.19	20.68	22.20
Fan motor heat (MBh)	46.84	51.02	67.09	65.91
Evaporator face area (sq ft)	43.00	43.00	43.00	43.00
Supply duct static pressure (in H2O)	2.000	2.000	1.750	1.750
Return duct static pressure (in H2O)	0.300	0.300	0.300	0.300
Component S.P. drop (in H2O)	1.170	1.275	1.697	1.674
Total static pressure (in H2O)	3.470	3.575	3.747	3.724
Supply motor bhp (bhp)	17.12	18.65	24.52	24.10
Supply fan rpm (rpm)	1356	1398	1554	1543
Supply fan efficiency (%)	67.13	66.92	64.58	64.71
Exhaust static pressure (in H2O)	0.300	0.300	0.300	0.300
Exhaust motor bhp (bhp)	4.44	4.44	4.44	4.44
Exhaust fan rpm (rpm)	487	487	487	487
System power (kW)	87.44	88.72	104.11	103.81
EER @ AHRI (EER)	10.1	10.1	9.9	9.9
IEER @ AHRI (EER)	16.9	16.9	17.3	17.3
Minimum circuit ampacity (A)	159.23	159.23	197.03	197.03
Maximum overcurrent protection (A)	175.00	175.00	225.00	225.00
Minimum disconnect switch size (A)	171.00	171.00	215.00	215.00
Recommended dual element (A)	175.00	175.00	225.00	225.00
Compressor 1 count (Each)	1.00	1.00	1.00	1.00
Compressor 1 RLA (A)	25.40	25.40	38.90	38.90
Compressor 2 count (Each)	1.00	1.00	2.00	2.00
Compressor 2 RLA (A)	37.20	37.20	25.40	25.40
Compressor 3 count (Each)	1.00	1.00	1.00	1.00
Compressor 3 RLA (A)	38.90	38.90	37.20	37.20
Supply fan motor FLA (A)	14.30	14.30	20.50	20.50
Supply motor count ( )	2	2	2	2
Supply fan count (Each)	2.00	2.00	2.00	2.00
Condenser fan FLA (A)	10.80	10.80	10.80	10.80
Exhaust fan motor FLA (A)	6.60	6.60	6.60	6.60
Other FLA (A)	2.00	2.00	2.00	2.00
R-410A refrigerant charge - circuit 1 (lb)	41.8	41.8	48.8	48.8
R-410A refrigerant charge - circuit 2 (lb)	45.0	45.0	45.3	45.3
Installed point load 1 (lb)	1085.6	1085.6	1060.9	1060.9

Tags	RTU-4N	RTU-4S	RTU-5N	RTU-5S
Installed point load 2 (lb)	1180.5	1180.5	1136.5	1136.5
Installed point load 3 (lb)	1217.6	1217.6	1236.7	1236.7
Installed point load 4 (lb)	1312.5	1312.5	1312.4	1312.4
Installed point load 5 (lb)	1349.6	1349.6	1412.6	1412.6
Installed point load 6 (lb)	1444.5	1444.5	1488.2	1488.2
Installed point load 7 (lb)	1458.8	1458.8	1558.2	1558.2
Installed point load 8 (lb)	1553.7	1553.7	1633.8	1633.8
Total installed weight (lb)	10602.8	10602.8	10839.2	10839.2
First X dimension (ft)	15.50	15.50	15.83	15.83
First Y dimension (ft)	4.99	4.99	4.96	4.96
Installed point load 1 - X (in)	4.000	4.000	4.000	4.000
Installed point load 1 - Y (in)	4.000	4.000	4.000	4.000
Installed point load 2 - X (in)	120.000	120.000	120.000	120.000
Installed point load 2 - Y (in)	112.000	112.000	112.000	112.000
Installed point load 3 - X (in)	236.000	236.000	236.000	236.000
Installed point load 4 - X (in)	332.000	332.000	332.000	332.000

**Mechanical Specifications - Commercial Rooftop Air Conditioning Units (Midrange)****Item: A1 - A10 Qty: 10 Tag(s): RTU-1N, RTU-1S, RTU-2N, RTU-2S, RTU-3N, RTU-3S, RTU-4N, RTU-4S, RTU-5N, RTU-5S****General - R410A**

Units shall be specifically designed for outdoor rooftop installation on a roof curb and be completely factory assembled and tested, piped, internally wired, fully charged with R-410A compressor oil and shipped in one piece. Units shall be available for direct expansion cooling only, or direct expansion cooling with natural gas, electric, hot water or steam heating. Filters, outside air system, exhaust air system, optional non-fused disconnect switches and all operating and safety controls shall be furnished factory installed. All units shall be cULus approved and factory run tested. Cooling capacity shall be rated in accordance with AHRI Standard 360. All units shall have decals and tags to aid in service and indicate caution areas. Electrical diagrams shall be printed on long life water resistant material and shall ship attached to control panel doors.

**Casing**

Exterior panels shall be zinc coated galvanized steel, phosphatized and painted with a slate grey air-dry finish durable enough to withstand a minimum of 672 hours consecutive salt spray application in accordance with standard ASTM B117. Screws shall be coated with zinc-plus-zinc chromate. Heavy gauge steel hinged access panels with tiebacks to secure door in open position shall provide access to filters and heating sections. Refrigeration components, supply air fan and compressor shall be accessible through removable panels as standard. Unit control panel, filter section, and gas heating section shall be accessible through hinged access panels as standard. Optional Double Wall Construction hinged access doors shall provide access to filters, return/exhaust air, heating and supply fan section. All access doors and panels shall have neoprene gaskets. Interior surfaces or exterior casing members shall have 1/2" fiberglass insulation. Unit base shall be watertight with heavy gauge formed load bearing members, formed recess and curb overhang. Unit lifting lugs shall accept chains or cables for rigging. Lifting lugs shall also serve as unit tiedown points.

**Hinged Access Doors**

Hinged access doors shall provide easy access to supply fan, filters, exhaust/return fan, and heating section. These access doors shall feature double wall construction with dual density insulation sandwiched between heavy gauge galvanized steel panels for strength and durability

**Air-Cooled Condenser Coil - R410A**

Condenser coils shall have all Aluminum Microchannel coils. All coils shall be leak tested at the factory to ensure pressure integrity. The condenser coil is pressure tested to 650psig Subcooling circuit(s) shall be provided as standard.

**Condenser Fans and Motors**

All condenser fans shall be vertical discharge, direct drive fans, statically balanced, with aluminum blades and zinc plated steel hubs. Condenser fan motors shall be three-phase motors with permanently lubricated ball bearings, built-in current and thermal overload protection and weathertight slingers over motor bearings.

**Evaporator Coil - R410A**

Internally enhanced copper tubing of 3/8" or 1/2" O.D. shall be mechanically bonded to heavyduty aluminum fins of configured design. All coils shall be equipped with thermal expansion valves and factory pressure and leak tested.

**Compressors - R410A**

The Trane Scroll compressor shall be industrial grade, direct drive 3600 RPM maximum speed scroll type. The motor shall be suction gas-cooled hermetic design. Compressor shall have centrifugal oil pump with dirt separator, oil sight glass, and oil charging valve. Compressor shall also be provided with thermostatic motor winding temperature control to protect against excessive motor temperatures resulting from over-/under-voltage or loss of charge, high and low pressure cutouts, and reset relay.

**Variable Speed Compressors**

The Trane eFlex variable speed compressor shall be capable of speed modulation from 1500 rpm to a maximum of 6000 rpm. This allows variable speed units to modulate capacities to 15% of full load or below. The compressor motor shall be a permanent magnet type for all but 575V units. Each compressor shall have a crankcase heater installed and properly sized to minimize the amount of liquid refrigerant present in the oil sump during off cycles. Each variable speed compressor is matched with a specially designed variable frequency drive which modulates the speed of the compressor motor and provides several compressor protection functions.

**Phase Monitor**

Shall protect 3-phase equipment from phase loss, phase reversal, and low voltage. Any fault condition shall produce a Failure Indicator LED, and send the unit into an emergency stop condition. cULus approved. (Standard on 20-75T units)

### Supply Fan

Supply fan motors shall be either open drip-proof or enclosed fan cooled. All supply fans shall be dynamically balanced in factory. Supply fan shall be test run in unit and shall reach rated rpm. All 60 Hz supply fan motors meet the Energy Independence Security Act of 2007 (EISA). All 50 Hz supply fan motors meet the U.S. Energy Policy Act of 1992 (EPACT).

### Direct-Drive Plenum Supply Fan

Supply fan shall be [one] [two] single width, single inlet 9-blade plenum fan. Fan blades shall be aluminum backward-inclined airfoil. Plenum fans shall be direct-driven. Entire assembly shall be completely isolated from unit and fan board by 2" deflection spring isolation. Multiple fan widths shall be available to optimize efficiency. Fan shall not require routine maintenance such as fan bearing lubrication, belt tensioning and replacement, sheave alignment, and setscrew torque checks.

### Variable Frequency Drive

Unit shall include factory-installed and tested variable frequency drive[s] (VFD) to provide motor speed modulation. The VFD shall receive a 0-10VDC speed signal from the unit controller. The drive will respond to the signal by accelerating or decelerating to maintain the controlling set point (duct static, space pressure, etc). VFD shall also include the following features:

1. Designed, constructed, and tested in accordance with NEMA ICS, NFPA, and IEC standards and housed in a plastic IP20 enclosure.
2. DC link reactors on both the positive and negative rails of the DC bus equal to 3% impedance to minimize power line harmonics.
3. Full rated output current continuously - 110% of rated current for 60 seconds and 160% of rated current for up to 0.5 second while starting.
4. Isolation between the Drive's power circuitry and control circuitry to ensure operator safety and to protect connected electronic control equipment  
from damage caused by voltage spikes, current surges, and ground loop currents.
5. Audible noise reduction through automatic adjustment of the carrier frequency and frequency avoidance.
6. Rated at 40C with a standard operating range of -10 to 50C (14 to 124F) ambient temperatures and 0 to 95% relative humidity
7. Self-diagnostics and motor protections such as: cULus listed overload, phase loss, and internal thermal overload.
8. Off/Stop and Auto/Start selector switches to start and stop the AC Drive and determine the speed reference.
  - a. On units with bypass, an AC Drive/Off/Bypass hand selector switch shall be provided in the unit control box
  - b. In DRIVE mode speed reference shall be provided by a 0-10 VDC analog input
9. A keypad interface which shall be programmable by language and feature multiple lines for easy reading.
10. Controlled and/or accessible points such as AC Drive Start/Stop, speed reference, and fault diagnostics.
11. Meter points such as motor power in HP, motor power in kW, motor kW-hr, motor current, motor voltage, hours run, DC link voltage, thermal load  
on motor, Thermal load on AC Drive and Heatsink temperature.
12. Troubleshooting features such as:
  - a. AC Drive memory storage of the last 10 faults and related operational data
  - b. Four simultaneous displays: frequency or speed, run time, output amps and output power

c. Keypad which shall display: Reference Signal Value, Output Frequency in Hz or percent, Output Amps, Motor HP, Motor kW, kW

13. Coated circuit boards for protection against corrosive environments

14. Field readable BACnet points to allow for communication of stauts, setpoints and diagnostics to the BAS.

#### **Extended Grease Lines**

Lines shall be provided to allow greasing of supply and exhaust/return fan bearings through the filter access door.

#### **Two-inch Spring Isolators**

Supply and Exhaust/Return fan (if applicable) assemblies shall be isolated with two-inch nominal deflection to reduce transmission of vibrations

#### **Modulating 100 Percent Exhaust Fan with Statitrac Control**

Two, double-inlet, forward-curved fans shall be mounted on a common shaft with fixed sheave drive. All fans shall be dynamically balanced and tested in factory before being installed in unit. Exhaust fan shall be test run as part of unit final run test. Unit shall reach rated rpm before fan shaft passes through first critical speed. Fan shaft shall be mounted on two grease lubricated ball bearings designed for 200,000-hour average life. Optional extended grease lines shall be provided to allow greasing of bearings from unit filter section. Fan motor and assembly shall be mounted on common base to allow consistent belt tension with no relative motion between fan and motor shafts. Entire assembly shall be completely isolated from unit and fan board by double deflection, rubber in shear isolators or spring isolation on motor sizes larger than five hp. For both CV and VAV rooftops, the 100 percent modulating exhaust discharge dampers (or VFD) shall be modulated in response to building pressure. A differential pressure control system, (Statitrac), shall use a differential pressure transducer to compare indoor building pressure to outdoor ambient atmospheric pressure. The FC exhaust fan shall be turned on when required to lower building static pressure setpoint. The (Statitrac) control system shall then modulate the discharge dampers (or VFD) to control the building pressure to within the adjustable, specified dead band that shall be adjustable at the Human Interface Panel. All 60 Hz exhaust fan motors meet the Energy Independence Security Act of 2007 (EISA).

#### **100 Percent Modulating Return Fan with Statitrac Control**

A single width plenum fan with airfoil blade shall be mounted on a shaft with fixed sheave drive. The fan shall be dynamically balanced for the operating envelop and tested in factory before being installed in unit. The plenum fan shall be test run as part of unit final run test. Fan operating envelop rpm shall be below first critical speed. Fan shaft shall be mounted on two grease lubricated ball or roller bearings designed for 200,000-hour average life. Extended grease lines shall be provided to allow greasing of bearings from section base rail. Fan motor and assembly shall be mounted on common base to allow consistent belt tension with no relative motion between fan and motor shafts. The entire assembly shall be completely isolated from unit with 2" spring isolators. The 100 percent modulating relief damper shall be modulated in response to building pressure. A differential pressure control system, (Statitrac), shall use a differential pressure transducer to compare indoor building pressure to outdoor ambient atmospheric pressure. The (Statitrac) control system shall modulate the discharge dampers to control the building pressure to within the adjustable, specified deadband that shall be adjustable at the Human Interface Panel. The return fan VFD shall modulate in response to return plenum pressure. All 60 Hz return fan motors meet the Energy Independence Security Act of 2007 (EISA).

#### **0-100 percent modulating economizer**

Operated through the primary temperature controls to automatically utilize OA for "free" cooling. Automatically modulated return and OA dampers shall maintain proper temperature in the conditioned space. Economizer shall be equipped with an automatic lockout when the outdoor high ambient temperature is too high for proper cooling. Minimum position control shall be standard and adjustable at the Human Interface Panel or with a remote potentiometer or through the building management system. A spring return motor shall ensure closure of OA dampers during unit shutdown or power interruption. Mechanical cooling shall be available to aid the economizer mode at any ambient. Low leak economizer dampers shall be standard with a leakage rate of 2.5 percent of nominal airflow (400 CFM/ton) at 1" wg. static pressure.

#### **Economizer Control with Comparative Enthalpy**

Two enthalpy sensors shall be provided to compare total heat content of the indoor air and outdoor air to determine the most efficient air source when economizing.

#### **low-leak economizer dampers**

Standard low leak dampers shall be provided with chlorinated polyvinyl chloride gasketing added to the damper blades and rolled stainless steel jamb seals to the sides of the damper assembly. Dampers shall have a leakage rate of 1% at 1.0 in WC pressure differential

**High efficiency throwaway, MERV 8**

Shall be two-inch high efficiency MERV 8 media filters with average dust spot efficiency of 25-35 percent and an average arrestance in excess of 90 percent when tested in accordance with ASHRAE 52-76.

**Unit Controller**

DDC microprocessor controls shall be provided to control all unit functions. The control system shall be suitable to control CV or VAV applications. The controls shall be factory-installed and mounted in the main control panel. All factory-installed controls shall be fully commissioned (run tested) at the factory. The unit shall have a Human Interface Panel with a 16 key keypad, a 2 line X 40 character clear English display as standard to provide the operator with full adjustment and display of control data functions. The unit controls shall be used as a stand-alone controller, or as part of a building management system involving multiple units.

1

The unit shall be equipped with a complete microprocessor control system. This system shall consist of temperature and pressure (thermistor and transducer) sensors, printed circuit boards (modules), and a unit mounted Human Interface Panel. Modules (boards) shall be individually replaceable for ease of service. All microprocessors, boards and sensors shall be factory mounted, wired and tested. The microprocessor boards shall be stand-alone DDC controls not dependent on communications with an on-site PC or a Building Management Network. The microprocessors shall be equipped with on-board diagnostics, indicating that all hardware, software and interconnecting wiring are in proper operating condition. The modules (boards) shall be protected to prevent RFI and voltage transients from affecting the board's circuits. All field wiring shall be terminated at separate, clearly marked terminal strip. Direct field wiring to the I/O boards is not acceptable. The microprocessor's memory shall be non-volatile EEPROM type requiring no battery or capacitive backup, while maintaining all data.

2

Zone sensors shall be available in several combinations with selectable features depending on sensor.

3

The Human Interface Panel's keypad display character format shall be 40 characters x 2 lines. The character font shall be 5 x 7 dot matrix plus cursor. The display shall be Supertwist Liquid Crystal Display (LCD) with blue characters on a ray/green background which provides high visibility and ease of interface. The display format shall be in clear English. Two or three digit coded displays are not acceptable.

4

The keypad shall be equipped with 16 individual touch-sensitive membrane key switches. The switches shall be divided into four separate sections and be password protected from change by unauthorized personnel. The six main menus shall be STATUS, SETPOINTS, DIAGNOSTICS, SETUP, CONFIGURATION and SERVICE MODE.

**BACnet Communication Interface Module**

Option shall provide control and monitoring of the rooftop by Tracer SC or a 3rd party building management system utilizing BACnet protocol.

**Unit Interrupt Rating (Standard Short Circuit Current Rating-SCCR)**

A 65,000 Amp rating shall be applied to the unit enclosure using a non-fused circuit breaker for disconnect switch purposes. Fan motors, compressors, and electric heat circuits shall be provided with protective devices that will provide the unit rated level of fault protection. The unit shall be marked with approved cULus markings and will adhere to cULus regulations.

**Factory Powered GFI Convenience Outlet**

A15A, 115V Ground Fault Interrupter convenience outlet shall be factory installed. It shall be wired and powered from a factory mounted transformer. Unit-mounted, non-fused disconnect with external handle shall be furnished with factory powered outlet

**Non-Fused Disconnect Switch with External Handle**

External handle SHALL enable the operator to disconnect unit power with the control box door closed for safety.



Unit Dimensions - Commercial Rooftop Air Conditioning Units (Midrange)

Item: A1 - A10 Qty: 10 Tag(s): RTU-1N, RTU-1S, RTU-2N, RTU-2S, RTU-3N, RTU-3S, RTU-4N, RTU-4S, RTU-5N, RTU-5S

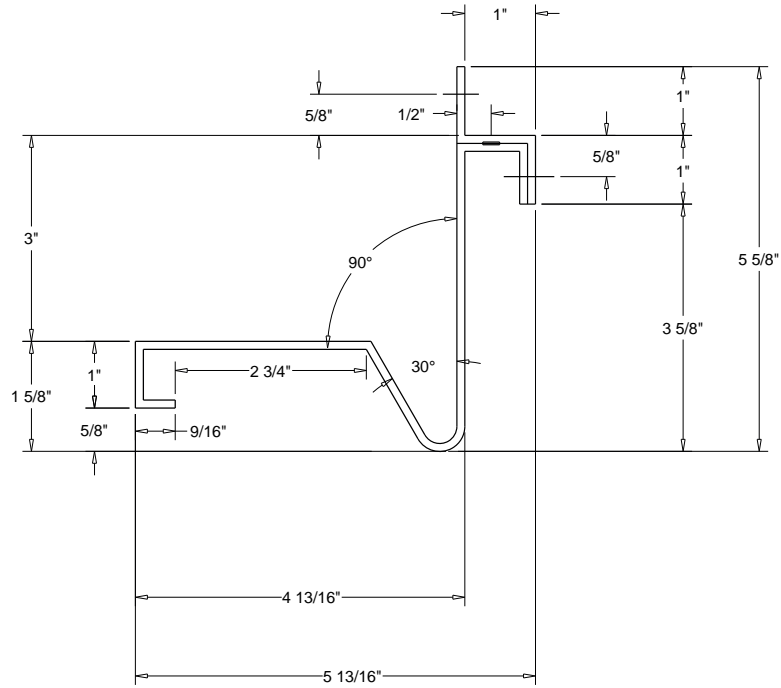

TYPICAL PEDESTAL AND BASE  
DIMENSION DRAWING

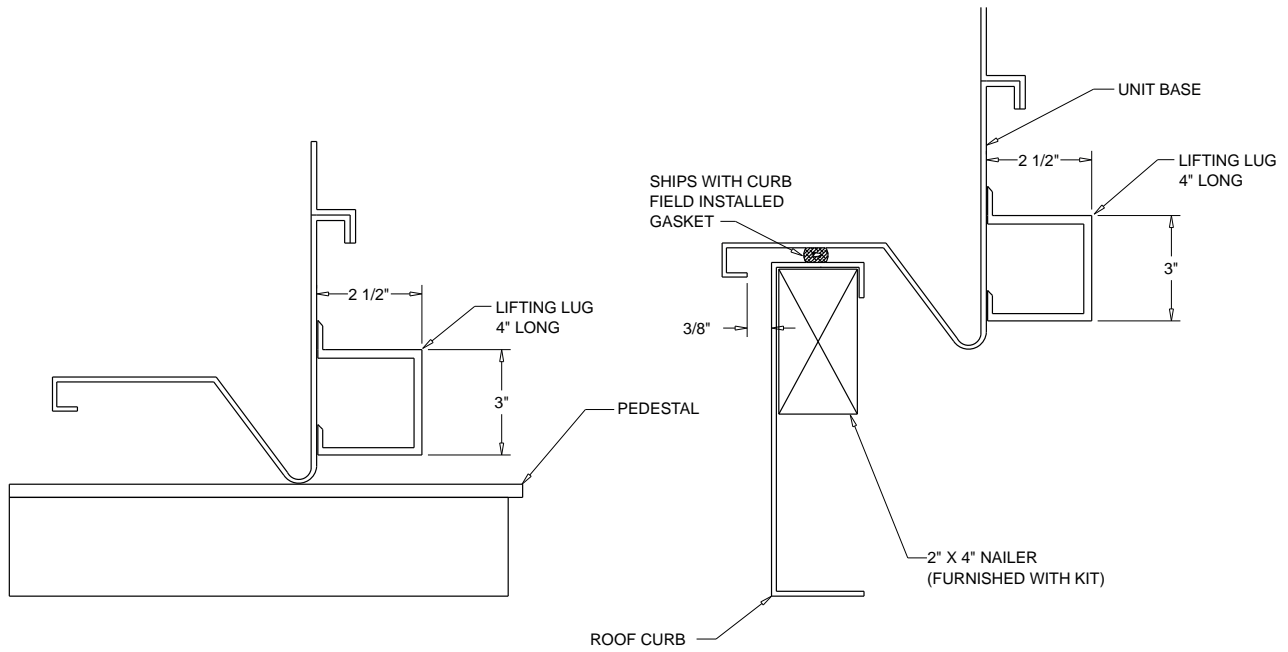

TYPICAL PEDESTAL AND BASE PAN  
DETAIL

TYPICAL ROOF CURB AND BASE PAN  
DETAIL

**Unit Dimensions - Commercial Rooftop Air Conditioning Units (Midrange)**

Item: A1 Qty: 1 Tag(s): RTU-1N

**ELECTRICAL / GENERAL DATA**

<p><b>TONS</b></p> <p>Model (Tonnage): SAHLF60 (60Ton)</p> <p>Unit Operating Voltage Range: 414-506</p> <p>Unit Primary Voltage: 460</p> <p>Unit Hertz: 60</p> <p>Unit Phase: 3</p> <p>EER: 10.5 EER</p> <p>IEER: 16.6 EER</p>	<p><b>GAS HEATING - PERFORMANCE</b></p> <p>Heating Input:</p> <p>Heating Output:</p> <p>Capacity Steps:</p> <p><b>HEATING - GENERAL DATA</b></p> <p>Gas inlet pressure: (in w.c.)</p> <p>Gas Pipe Connection Size:</p>
<p><b>COMPRESSOR</b></p> <p>Compressor 1 Count: 1.00 Each</p> <p>Compressor 1 RLA: 22.20 A</p> <p>Compressor 2 Count: 1.00 Each</p> <p>Compressor 2 RLA: 25.50 A</p> <p>Compressor 3 Count: 1.00 Each</p> <p>Compressor 3 RLA: 38.90 A</p>	<p><b>ELECTRIC HEATER</b></p> <p>Electric Heater Kw:</p> <p>Electric Heater Full Load Amps:</p>
<p><b>SUPPLY FAN MOTOR</b></p> <p>Number of Fans: 2.00 Each</p> <p>Number of Motors: 2</p> <p>Total Horsepower: (8) 15 hp DDP 120% width</p> <p>Supply Fan Motor Full Load Amps: 11.00 A</p> <p>Supply Fan Efficiency: 64.42 %</p>	<p><b>EXHAUST / RETURN FAN MOTOR SECTION</b></p> <p>Number: Value not available</p> <p>Horsepower (Each): 100% Return 7.5 hp with Statitrac building pressure control</p> <p>Exhaust/Return Fan Motor FLA: 9.80 A</p>
<p><b>CONDENSER FAN MOTOR</b></p> <p>Number: 6</p> <p>Horsepower (each): 1.0</p> <p>Condenser Fan Motor Full Load Amps (Total): 10.8</p>	<p><b>FILTERS - TYPE</b></p> <p>Type:</p> <p>Furnished: YES</p> <p>Number: 35</p> <p>Recommended Size: 16" x20" x2"</p>
<p><b>EVAPORATIVE CONDENSER (7)</b></p> <p>Pump Horsepower: N/A</p> <p>Pump Full Load Amps: N/A</p> <p>Sump Heater Full Load Amps: N/A</p> <p>Sump Heater kW: N/A</p>	<p><b>PREFILTERS</b></p> <p>Furnished:</p> <p>Number:</p> <p>Recommended Size:</p>
<p><b>REFRIGERANT TYPE (6)</b></p> <p>Charge Type: R-410A</p> <p>Factory Charge (Circuit #1): 41.8 lb</p> <p>Factory Charge (Circuit #2): 40.0 lb</p>	<p><b>FINAL FILTERS - TYPE</b></p> <p>Type:</p> <p>Furnished:</p> <p>Number:</p> <p>Recommended Size:</p> <p><b>PREFILTERS</b></p> <p>Furnished:</p> <p>Number:</p> <p>Recommended Size:</p>

Notes:

- LOAD 1=Current of the largest motor (compressor or fan motor); LOAD 2=Sum of the currents of all remaining motors; LOAD 3 =Current of electric heaters  
LOAD 4 =Control Power Transformer (20-40 and 24-48 ton units add 3 FL amps for wire sizing formula, 50-75 and 59 - 89 ton units add 6 FL amps)
- For Electric Heat MCA, MOP, RDE values, calculate for both cooling and heating modes. (When determining LOADS, the compressors do not operate when the unit is in heating mode) (On 70-89 ton single source units, heating Load 4 = 12 amps on 200,230 volt units and 9 amps on 460,575 volt units)
- If selected Max Over Cur is less than the Min Cir Amp, then select the lowest maximum fuse size which is equal to or larger than the Min Cir Amp, provided the selected fuse size does not exceed 800 amps.
- If the selected Recommended Dual Element fuse size is greater than the selected Max Over Cur Protection value, then select the Recommended Dual Element fuse size value to equal the Max Over Protection value.
- Compressor KW at AHRI rating conditions of 80/67 -95
- Refrigerant charge is an approx. value. For a more precise value, see unit nameplate and service instructions.
- Sump Heater is an optional feature.
- Total Horsepower is the combined Horsepower for the Supply Fan Motors.



**Unit Dimensions - Commercial Rooftop Air Conditioning Units (Midrange)**

Item: A2 Qty: 1 **Tag(s): RTU-1S**

**ELECTRICAL / GENERAL DATA**

<p><b>TONS</b></p> <p>Model (Tonnage): SXHLF70 (70Ton)</p> <p>Unit Operating Voltage Range: 414-506</p> <p>Unit Primary Voltage: 460</p> <p>Unit Hertz: 60</p> <p>Unit Phase: 3</p> <p>EER: 10.1 EER</p> <p>IEER: 16.9 EER</p>	<p><b>GAS HEATING - PERFORMANCE</b></p> <p>Heating Input:</p> <p>Heating Output:</p> <p>Capacity Steps:</p> <p><b>HEATING - GENERAL DATA</b></p> <p>Gas inlet pressure: (in w.c.)</p> <p>Gas Pipe Connection Size:</p>
<p><b>COMPRESSOR</b></p> <p>Compressor 1 Count: 1.00 Each</p> <p>Compressor 1 RL A: 25.40 A</p> <p>Compressor 2 Count: 1.00 Each</p> <p>Compressor 2 RL A: 37.20 A</p> <p>Compressor 3 Count: 1.00 Each</p> <p>Compressor 3 RL A: 38.90 A</p>	<p><b>ELECTRIC HEATER</b></p> <p>Electric Heater Kw:</p> <p>Electric Heater Full Load Amps:</p>
<p><b>SUPPLY FAN MOTOR</b></p> <p>Number of Fans: 2.00 Each</p> <p>Number of Motors: 2</p> <p>Total Horsepower: (8) 20 hp DDP 120% width</p> <p>Supply Fan Motor Full Load Amps: 14.30 A</p> <p>Supply Fan Efficiency: 66.96 %</p>	<p><b>EXHAUST / RETURN FAN MOTOR SECTION</b></p> <p>Number: Value not available</p> <p>Horsepower (Each): 100% Return 7.5 hp with Statitrac building pressure control</p> <p>Exhaust/Return Fan Motor FLA: 9.80 A</p>
<p><b>CONDENSER FAN MOTOR</b></p> <p>Number: 6</p> <p>Horsepower (each): 1.0</p> <p>Condenser Fan Motor Full Load Amps (Total): 10.8</p>	<p><b>FILTERS - TYPE</b></p> <p>Type:</p> <p>Furnished: YES</p> <p>Number: 35</p> <p>Recommended Size: 16" x20" x2"</p>
<p><b>EVAPORATIVE CONDENSER (7)</b></p> <p>Pump Horsepower: N/A</p> <p>Pump Full Load Amps: N/A</p> <p>Sump Heater Full Load Amps: N/A</p> <p>Sump Heater kW: N/A</p>	<p><b>PREFILTERS</b></p> <p>Furnished:</p> <p>Number:</p> <p>Recommended Size:</p>
<p><b>REFRIGERANT TYPE (6)</b></p> <p>Charge Type: R-410A</p> <p>Factory Charge (Circuit #1): 42.3 lb</p> <p>Factory Charge (Circuit #2): 45.0 lb</p>	<p><b>FINAL FILTERS - TYPE</b></p> <p>Type:</p> <p>Furnished:</p> <p>Number:</p> <p>Recommended Size:</p> <p><b>PREFILTERS</b></p> <p>Furnished:</p> <p>Number:</p> <p>Recommended Size:</p>

Notes:

- LOAD 1=Current of the largest motor (compressor or fan motor); LOAD 2=Sum of the currents of all remaining motors; LOAD 3 =Current of electric heaters  
LOAD 4 =Control Power Transformer (20-40 and 24-48 ton units add 3 FL amps for wire sizing formula, 50-75 and 59 - 89 ton units add 6 FL amps)
- For Electric Heat MCA, MOP, RDE values, calculate for both cooling and heating modes. (When determining LOADS, the compressors do not operate when the unit is in heating mode) (On 70-89 ton single source units, heating Load 4 = 12 amps on 200,230 volt units and 9 amps on 460,575 volt units)
- If selected Max Over Cur is less than the Min Cir Amp, then select the lowest maximum fuse size which is equal to or larger than the Min Cir Amp, provided the selected fuse size does not exceed 800 amps.
- If the selected Recommended Dual Element fuse size is greater than the selected Max Over Cur Protection value, then select the Recommended Dual Element fuse size value to equal the Max Over Protection value.
- Compressor KW at AHRI rating conditions of 80/67 -95
- Refrigerant charge is an approx. value. For a more precise value, see unit nameplate and service instructions.
- Sump Heater is an optional feature.
- Total Horsepower is the combined Horsepower for the Supply Fan Motors.

**Unit Dimensions - Commercial Rooftop Air Conditioning Units (Midrange)**

Item: A3 - A10 Qty: 8 Tag(s): RTU-2N, RTU-2S, RTU-3N, RTU-3S, RTU-4N, RTU-4S, RTU-5N, RTU-5S

- NOTES:
1. VERIFY WEIGHT, CONNECTION, AND ALL DIMENSION WITH INSTALLER DOCUMENTS BEFORE INSTALLATION
  2. LOW AMBIENT DAMPER ONLY COMES WITH SELECTED UNIT.
  3. OVERALL UNIT WIDTH INCREASES 5/8" BEYOND LIFTING LUG WITH ULTRA LOW LEAK POWER EXHAUST DAMPERS
  4. RETURN AIR OPENING CONFIGURATION FOR USES WITH NO AIR OPTION, BAROMETRIC RELIEF, AND EXHAUST FAN.
  5. IF FIELD CONVERTING SUPPLY & RETURN OPENING(S) TO HORIZONTAL OR VERTICAL AIRFLOW, FACTORY MUST VERIFY IF UNIT OPTIONS WILL ALLOW IT. FACTORY INSTALLATION IS ALWAYS RECOMMENDED.

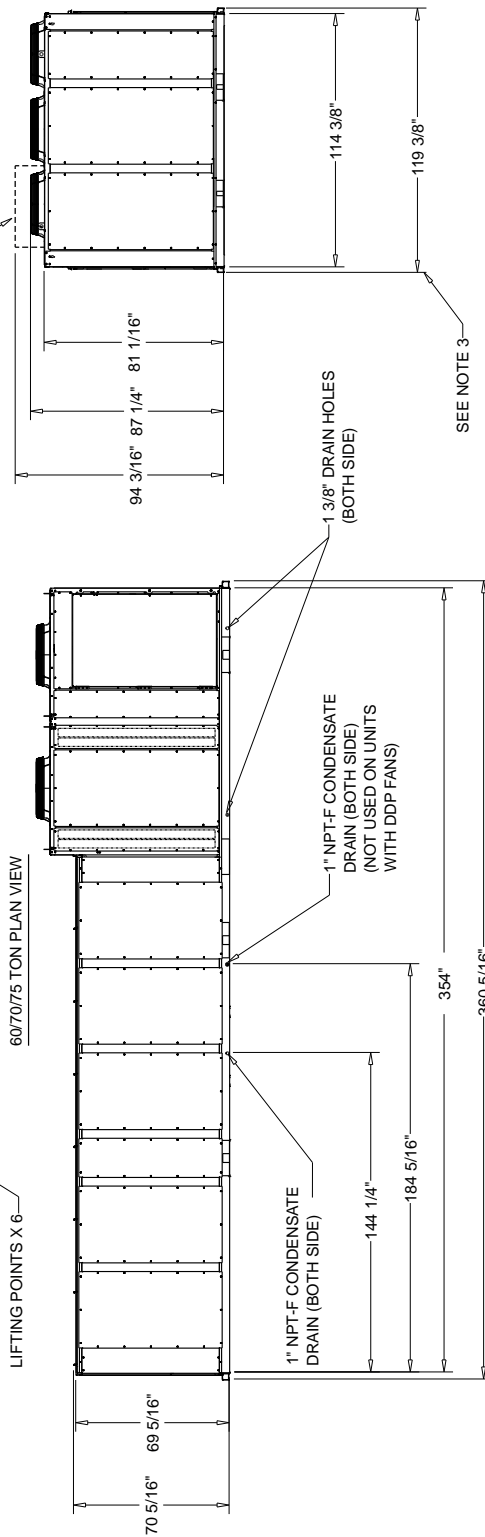
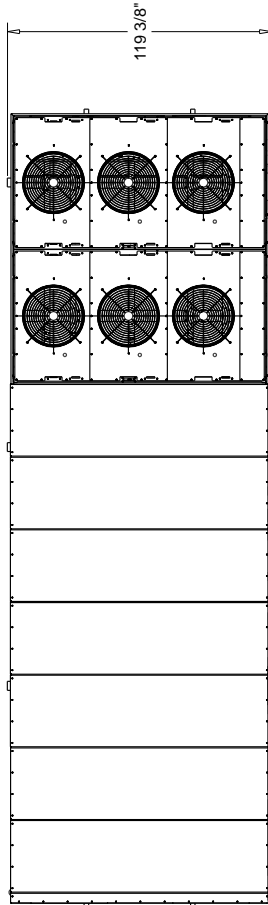

60/70/75 TON FRONT VIEW

60/70/75 TON LEFT SIDE VIEW

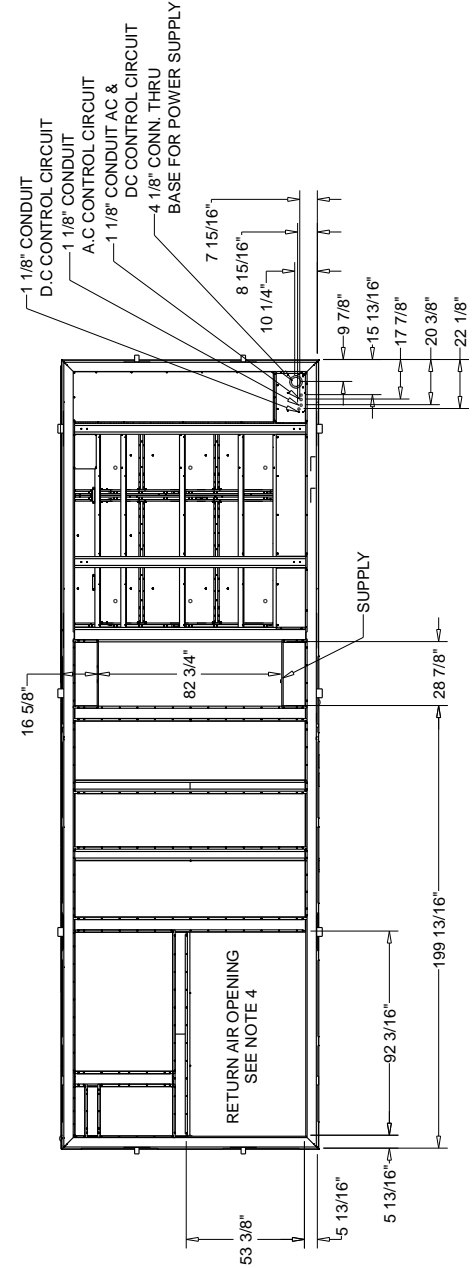

60/70/75 TON PLAN VIEW OF UNIT

**Unit Dimensions - Commercial Rooftop Air Conditioning Units (Midrange)**

Item: A3 Qty: 1 Tag(s): RTU-2N

**ELECTRICAL / GENERAL DATA**

<p><b>TONS</b></p> <p>Model (Tonnage): SAHLF70 (70Ton)</p> <p>Unit Operating Voltage Range: 414-506</p> <p>Unit Primary Voltage: 460</p> <p>Unit Hertz: 60</p> <p>Unit Phase: 3</p> <p>EER: 10.1 EER</p> <p>IEER: 16.9 EER</p>	<p><b>GAS HEATING - PERFORMANCE</b></p> <p>Heating Input:</p> <p>Heating Output:</p> <p>Capacity Steps:</p> <p><b>HEATING - GENERAL DATA</b></p> <p>Gas inlet pressure: (in w.c.)</p> <p>Gas Pipe Connection Size:</p>
<p><b>COMPRESSOR</b></p> <p>Compressor 1 Count: 1.00 Each</p> <p>Compressor 1 RL A: 25.40 A</p> <p>Compressor 2 Count: 1.00 Each</p> <p>Compressor 2 RL A: 37.20 A</p> <p>Compressor 3 Count: 1.00 Each</p> <p>Compressor 3 RL A: 38.90 A</p>	<p><b>ELECTRIC HEATER</b></p> <p>Electric Heater Kw:</p> <p>Electric Heater Full Load Amps:</p>
<p><b>SUPPLY FAN MOTOR</b></p> <p>Number of Fans: 2.00 Each</p> <p>Number of Motors: 2</p> <p>Total Horsepower: (8) 30 hp DDP 80% width</p> <p>Supply Fan Motor Full Load Amps: 18.00 A</p> <p>Supply Fan Efficiency: 61.16 %</p>	<p><b>EXHAUST / RETURN FAN MOTOR SECTION</b></p> <p>Number: Value not available</p> <p>Horsepower (Each): 100% Exhaust - 5 hp with Statitrac building pressure control</p> <p>Exhaust/Return Fan Motor FLA: 6.60 A</p>
<p><b>CONDENSER FAN MOTOR</b></p> <p>Number: 6</p> <p>Horsepower (each): 1.0</p> <p>Condenser Fan Motor Full Load Amps (Total): 10.8</p>	<p><b>FILTERS - TYPE</b></p> <p>Type:</p> <p>Furnished: YES</p> <p>Number: 35</p> <p>Recommended Size: 16" x20" x2"</p>
<p><b>EVAPORATIVE CONDENSER (7)</b></p> <p>Pump Horsepower: N/A</p> <p>Pump Full Load Amps: N/A</p> <p>Sump Heater Full Load Amps: N/A</p> <p>Sump Heater kW: N/A</p>	<p><b>PREFILTERS</b></p> <p>Furnished:</p> <p>Number:</p> <p>Recommended Size:</p>
<p><b>REFRIGERANT TYPE (6)</b></p> <p>Charge Type: R-410A</p> <p>Factory Charge (Circuit #1): 41.8 lb</p> <p>Factory Charge (Circuit #2): 45.0 lb</p>	<p><b>FINAL FILTERS - TYPE</b></p> <p>Type:</p> <p>Furnished:</p> <p>Number:</p> <p>Recommended Size:</p> <p><b>PREFILTERS</b></p> <p>Furnished:</p> <p>Number:</p> <p>Recommended Size:</p>

Notes:

- LOAD 1=Current of the largest motor (compressor or fan motor); LOAD 2=Sum of the currents of all remaining motors; LOAD 3 =Current of electric heaters  
LOAD 4 =Control Power Transformer (20-40 and 24-48 ton units add 3 FL amps for wire sizing formula, 50-75 and 59 - 89 ton units add 6 FL amps)
- For Electric Heat MCA, MOP, RDE values, calculate for both cooling and heating modes. (When determining LOADS, the compressors do not operate when the unit is in heating mode) (On 70-89 ton single source units, heating Load 4 = 12 amps on 200,230 volt units and 9 amps on 460,575 volt units)
- If selected Max Over Cur is less than the Min Clr Amp, then select the lowest maximum fuse size which is equal to or larger than the Min Cir Amp, provided the selected fuse size does not exceed 800 amps.
- If the selected Recommended Dual Element fuse size is greater than the selected Max Over Cur Protection value, then select the Recommended Dual Element fuse size value to equal the Max Over Protection value.
- Compressor KW at AHRI rating conditions of 80/67 -95
- Refrigerant charge is an approx. value. For a more precise value, see unit nameplate and service instructions.
- Sump Heater is an optional feature.
- Total Horsepower is the combined Horsepower for the Supply Fan Motors.

**Unit Dimensions - Commercial Rooftop Air Conditioning Units (Midrange)**

Item: A4 Qty: 1 Tag(s): RTU-2S

**ELECTRICAL / GENERAL DATA**

<p><b>TONS</b></p> <p>Model (Tonnage): SAHLF70 (70Ton)</p> <p>Unit Operating Voltage Range: 414-506</p> <p>Unit Primary Voltage: 460</p> <p>Unit Hertz: 60</p> <p>Unit Phase: 3</p> <p>EER: 10.1 EER</p> <p>IEER: 16.9 EER</p>	<p><b>GAS HEATING - PERFORMANCE</b></p> <p>Heating Input:</p> <p>Heating Output:</p> <p>Capacity Steps:</p> <p><b>HEATING - GENERAL DATA</b></p> <p>Gas inlet pressure: (in w.c.)</p> <p>Gas Pipe Connection Size:</p>
<p><b>COMPRESSOR</b></p> <p>Compressor 1 Count: 1.00 Each</p> <p>Compressor 1 RLA: 25.40 A</p> <p>Compressor 2 Count: 1.00 Each</p> <p>Compressor 2 RLA: 37.20 A</p> <p>Compressor 3 Count: 1.00 Each</p> <p>Compressor 3 RLA: 38.90 A</p>	<p><b>ELECTRIC HEATER</b></p> <p>Electric Heater Kw:</p> <p>Electric Heater Full Load Amps:</p>
<p><b>SUPPLY FAN MOTOR</b></p> <p>Number of Fans: 2.00 Each</p> <p>Number of Motors: 2</p> <p>Total Horsepower: (8) 30 hp DDP 80% width</p> <p>Supply Fan Motor Full Load Amps: 18.00 A</p> <p>Supply Fan Efficiency: 61.47 %</p>	<p><b>EXHAUST / RETURN FAN MOTOR SECTION</b></p> <p>Number: Value not available</p> <p>Horsepower (Each): 100% Exhaust - 5 hp with Statitrac building pressure control</p> <p>Exhaust/Return Fan Motor FLA: 6.60 A</p>
<p><b>CONDENSER FAN MOTOR</b></p> <p>Number: 6</p> <p>Horsepower (each): 1.0</p> <p>Condenser Fan Motor Full Load Amps (Total): 10.8</p>	<p><b>FILTERS - TYPE</b></p> <p>Type:</p> <p>Furnished: YES</p> <p>Number: 35</p> <p>Recommended Size: 16" x20" x2"</p>
<p><b>EVAPORATIVE CONDENSER (7)</b></p> <p>Pump Horsepower: N/A</p> <p>Pump Full Load Amps: N/A</p> <p>Sump Heater Full Load Amps: N/A</p> <p>Sump Heater kW: N/A</p>	<p><b>PREFILTERS</b></p> <p>Furnished:</p> <p>Number:</p> <p>Recommended Size:</p>
<p><b>REFRIGERANT TYPE (6)</b></p> <p>Charge Type: R-410A</p> <p>Factory Charge (Circuit #1): 41.8 lb</p> <p>Factory Charge (Circuit #2): 45.0 lb</p>	<p><b>FINAL FILTERS - TYPE</b></p> <p>Type:</p> <p>Furnished:</p> <p>Number:</p> <p>Recommended Size:</p> <p><b>PREFILTERS</b></p> <p>Furnished:</p> <p>Number:</p> <p>Recommended Size:</p>

Notes:

- LOAD 1=Current of the largest motor (compressor or fan motor); LOAD 2=Sum of the currents of all remaining motors; LOAD 3 =Current of electric heaters  
LOAD 4 =Control Power Transformer (20-40 and 24-48 ton units add 3 FL amps for wire sizing formula, 50-75 and 59 - 89 ton units add 6 FL amps)
- For Electric Heat MCA, MOP, RDE values, calculate for both cooling and heating modes. (When determining LOADS, the compressors do not operate when the unit is in heating mode) (On 70-89 ton single source units, heating Load 4 = 12 amps on 200,230 volt units and 9 amps on 460,575 volt units)
- If selected Max Over Cur is less than the Min Cir Amp, then select the lowest maximum fuse size which is equal to or larger than the Min Cir Amp, provided the selected fuse size does not exceed 800 amps.
- If the selected Recommended Dual Element fuse size is greater than the selected Max Over Cur Protection value, then select the Recommended Dual Element fuse size value to equal the Max Over Protection value.
- Compressor KW at AHRI rating conditions of 80/67 -95
- Refrigerant charge is an approx. value. For a more precise value, see unit nameplate and service instructions.
- Sump Heater is an optional feature.
- Total Horsepower is the combined Horsepower for the Supply Fan Motors.

**Unit Dimensions - Commercial Rooftop Air Conditioning Units (Midrange)**

Item: A5 Qty: 1 Tag(s): RTU-3N

**ELECTRICAL / GENERAL DATA**

<p><b>TONS</b></p> <p>Model (Tonnage): SAHLF70 (70Ton)</p> <p>Unit Operating Voltage Range: 414-506</p> <p>Unit Primary Voltage: 460</p> <p>Unit Hertz: 60</p> <p>Unit Phase: 3</p> <p>EER: 10.1 EER</p> <p>IEER: 16.9 EER</p>	<p><b>GAS HEATING - PERFORMANCE</b></p> <p>Heating Input:</p> <p>Heating Output:</p> <p>Capacity Steps:</p> <p><b>HEATING - GENERAL DATA</b></p> <p>Gas inlet pressure: (in w.c.)</p> <p>Gas Pipe Connection Size:</p>
<p><b>COMPRESSOR</b></p> <p>Compressor 1 Count: 1.00 Each</p> <p>Compressor 1 RL A: 25.40 A</p> <p>Compressor 2 Count: 1.00 Each</p> <p>Compressor 2 RL A: 37.20 A</p> <p>Compressor 3 Count: 1.00 Each</p> <p>Compressor 3 RL A: 38.90 A</p>	<p><b>ELECTRIC HEATER</b></p> <p>Electric Heater Kw:</p> <p>Electric Heater Full Load Amps:</p>
<p><b>SUPPLY FAN MOTOR</b></p> <p>Number of Fans: 2.00 Each</p> <p>Number of Motors: 2</p> <p>Total Horsepower: (8) 20 hp DDP 120% width</p> <p>Supply Fan Motor Full Load Amps: 14.30 A</p> <p>Supply Fan Efficiency: 67.10 %</p>	<p><b>EXHAUST / RETURN FAN MOTOR SECTION</b></p> <p>Number: Value not available</p> <p>Horsepower (Each): 100% Exhaust - 5 hp with Statitrac building pressure control</p> <p>Exhaust/Return Fan Motor FLA: 6.60 A</p>
<p><b>CONDENSER FAN MOTOR</b></p> <p>Number: 6</p> <p>Horsepower (each): 1.0</p> <p>Condenser Fan Motor Full Load Amps (Total): 10.8</p>	<p><b>FILTERS - TYPE</b></p> <p>Type:</p> <p>Furnished: YES</p> <p>Number: 35</p> <p>Recommended Size: 16" x20" x2"</p>
<p><b>EVAPORATIVE CONDENSER (7)</b></p> <p>Pump Horsepower: N/A</p> <p>Pump Full Load Amps: N/A</p> <p>Sump Heater Full Load Amps: N/A</p> <p>Sump Heater kW: N/A</p>	<p><b>PREFILTERS</b></p> <p>Furnished:</p> <p>Number:</p> <p>Recommended Size:</p>
<p><b>REFRIGERANT TYPE (6)</b></p> <p>Charge Type: R-410A</p> <p>Factory Charge (Circuit #1): 41.8 lb</p> <p>Factory Charge (Circuit #2): 45.0 lb</p>	<p><b>FINAL FILTERS - TYPE</b></p> <p>Type:</p> <p>Furnished:</p> <p>Number:</p> <p>Recommended Size:</p> <p><b>PREFILTERS</b></p> <p>Furnished:</p> <p>Number:</p> <p>Recommended Size:</p>

Notes:

- LOAD 1=Current of the largest motor (compressor or fan motor); LOAD 2=Sum of the currents of all remaining motors; LOAD 3 =Current of electric heaters  
LOAD 4 =Control Power Transformer (20-40 and 24-48 ton units add 3 FL amps for wire sizing formula, 50-75 and 59 - 89 ton units add 6 FL amps)
- For Electric Heat MCA, MOP, RDE values, calculate for both cooling and heating modes. (When determining LOADS, the compressors do not operate when the unit is in heating mode) (On 70-89 ton single source units, heating Load 4 = 12 amps on 200,230 volt units and 9 amps on 460,575 volt units)
- If selected Max Over Cur is less than the Min Cir Amp, then select the lowest maximum fuse size which is equal to or larger than the Min Cir Amp, provided the selected fuse size does not exceed 800 amps.
- If the selected Recommended Dual Element fuse size is greater than the selected Max Over Cur Protection value, then select the Recommended Dual Element fuse size value to equal the Max Over Protection value.
- Compressor KW at AHRI rating conditions of 80/67 -95
- Refrigerant charge is an approx. value. For a more precise value, see unit nameplate and service instructions.
- Sump Heater is an optional feature.
- Total Horsepower is the combined Horsepower for the Supply Fan Motors.

**Unit Dimensions - Commercial Rooftop Air Conditioning Units (Midrange)**

Item: A6 Qty: 1 Tag(s): RTU-3S

**ELECTRICAL / GENERAL DATA**

<p><b>TONS</b></p> <p>Model (Tonnage): SAHLF70 (70Ton)                  Unit Operating Voltage Range: 414-506                  Unit Primary Voltage: 460                  Unit Hertz: 60                  Unit Phase: 3</p> <p>EER: 10.1 EER                  IEER: 16.9 EER</p>	<p><b>GAS HEATING - PERFORMANCE</b></p> <p>Heating Input:                  Heating Output:                  Capacity Steps:</p> <p><b>HEATING - GENERAL DATA</b>                  Gas inlet pressure: (in w.c.)                  Gas Pipe Connection Size:</p>
<p><b>COMPRESSOR</b></p> <p>Compressor 1 Count: 1.00 Each                  Compressor 1 RL A: 25.40 A                  Compressor 2 Count: 1.00 Each                  Compressor 2 RL A: 37.20 A                  Compressor 3 Count: 1.00 Each                  Compressor 3 RL A: 38.90 A</p>	<p><b>ELECTRIC HEATER</b></p> <p>Electric Heater Kw:                  Electric Heater Full Load Amps:</p>
<p><b>SUPPLY FAN MOTOR</b></p> <p>Number of Fans: 2.00 Each                  Number of Motors: 2                  Total Horsepower: (8) 20 hp DDP 120% width                  Supply Fan Motor Full Load Amps: 14.30 A                  Supply Fan Efficiency: 66.94 %</p>	<p><b>EXHAUST / RETURN FAN MOTOR SECTION</b></p> <p>Number: Value not available                  Horsepower (Each): 100% Exhaust - 5 hp with Statitrac building pressure control                  Exhaust/Return Fan Motor FLA: 6.60 A</p>
<p><b>CONDENSER FAN MOTOR</b></p> <p>Number: 6                  Horsepower (each): 1.0                  Condenser Fan Motor Full Load Amps (Total): 10.8</p>	<p><b>FILTERS - TYPE</b></p> <p>Type:                  Furnished: YES                  Number: 35                  Recommended Size: 16" x20" x2"</p>
<p><b>EVAPORATIVE CONDENSER (7)</b></p> <p>Pump Horsepower: N/A                  Pump Full Load Amps: N/A                  Sump Heater Full Load Amps: N/A                  Sump Heater kW: N/A</p>	<p><b>PREFILTERS</b></p> <p>Furnished:                  Number:                  Recommended Size:</p>
<p><b>REFRIGERANT TYPE (6)</b></p> <p>Charge Type: R-410A                  Factory Charge (Circuit #1): 41.8 lb                  Factory Charge (Circuit #2): 45.0 lb</p>	<p><b>FINAL FILTERS - TYPE</b></p> <p>Type:                  Furnished:                  Number:                  Recommended Size:</p> <p><b>PREFILTERS</b></p> <p>Furnished:                  Number:                  Recommended Size:</p>

Notes:

- LOAD 1=Current of the largest motor (compressor or fan motor); LOAD 2=Sum of the currents of all remaining motors; LOAD 3 =Current of electric heaters  
 LOAD 4 =Control Power Transformer (20-40 and 24-48 ton units add 3 FL amps for wire sizing formula, 50-75 and 59 - 89 ton units add 6 FL amps)
- For Electric Heat MCA, MOP, RDE values, calculate for both cooling and heating modes. (When determining LOADS, the compressors do not operate when the unit is in heating mode) (On 70-89 ton single source units, heating Load 4 = 12 amps on 200,230 volt units and 9 amps on 460,575 volt units)
- If selected Max Over Cur is less than the Min Cir Amp, then select the lowest maximum fuse size which is equal to or larger than the Min Cir Amp, provided the selected fuse size does not exceed 800 amps.
- If the selected Recommended Dual Element fuse size is greater than the selected Max Over Cur Protection value, then select the Recommended Dual Element fuse size value to equal the Max Over Protection value.
- Compressor KW at AHRI rating conditions of 80/67 -95
- Refrigerant charge is an approx. value. For a more precise value, see unit nameplate and service instructions.
- Sump Heater is an optional feature.
- Total Horsepower is the combined Horsepower for the Supply Fan Motors.

**Unit Dimensions - Commercial Rooftop Air Conditioning Units (Midrange)**

Item: A7 Qty: 1 Tag(s): RTU-4N

**ELECTRICAL / GENERAL DATA**

<p><b>TONS</b></p> <p>Model (Tonnage): SAHLF70 (70Ton)</p> <p>Unit Operating Voltage Range: 414-506</p> <p>Unit Primary Voltage: 460</p> <p>Unit Hertz: 60</p> <p>Unit Phase: 3</p> <p>EER: 10.1 EER</p> <p>IEER: 16.9 EER</p>	<p><b>GAS HEATING - PERFORMANCE</b></p> <p>Heating Input:</p> <p>Heating Output:</p> <p>Capacity Steps:</p> <p><b>HEATING - GENERAL DATA</b></p> <p>Gas inlet pressure: (in w.c.)</p> <p>Gas Pipe Connection Size:</p>
<p><b>COMPRESSOR</b></p> <p>Compressor 1 Count: 1.00 Each</p> <p>Compressor 1 RL A: 25.40 A</p> <p>Compressor 2 Count: 1.00 Each</p> <p>Compressor 2 RL A: 37.20 A</p> <p>Compressor 3 Count: 1.00 Each</p> <p>Compressor 3 RL A: 38.90 A</p>	<p><b>ELECTRIC HEATER</b></p> <p>Electric Heater Kw:</p> <p>Electric Heater Full Load Amps:</p>
<p><b>SUPPLY FAN MOTOR</b></p> <p>Number of Fans: 2.00 Each</p> <p>Number of Motors: 2</p> <p>Total Horsepower: (8) 20 hp DDP 120% width</p> <p>Supply Fan Motor Full Load Amps: 14.30 A</p> <p>Supply Fan Efficiency: 67.13 %</p>	<p><b>EXHAUST / RETURN FAN MOTOR SECTION</b></p> <p>Number: Value not available</p> <p>Horsepower (Each): 100% Exhaust - 5 hp with Statitrac building pressure control</p> <p>Exhaust/Return Fan Motor FLA: 6.60 A</p>
<p><b>CONDENSER FAN MOTOR</b></p> <p>Number: 6</p> <p>Horsepower (each): 1.0</p> <p>Condenser Fan Motor Full Load Amps (Total): 10.8</p>	<p><b>FILTERS - TYPE</b></p> <p>Type:</p> <p>Furnished: YES</p> <p>Number: 35</p> <p>Recommended Size: 16" x20" x2"</p>
<p><b>EVAPORATIVE CONDENSER (7)</b></p> <p>Pump Horsepower: N/A</p> <p>Pump Full Load Amps: N/A</p> <p>Sump Heater Full Load Amps: N/A</p> <p>Sump Heater kW: N/A</p>	<p><b>PREFILTERS</b></p> <p>Furnished:</p> <p>Number:</p> <p>Recommended Size:</p>
<p><b>REFRIGERANT TYPE (6)</b></p> <p>Charge Type: R-410A</p> <p>Factory Charge (Circuit #1): 41.8 lb</p> <p>Factory Charge (Circuit #2): 45.0 lb</p>	<p><b>FINAL FILTERS - TYPE</b></p> <p>Type:</p> <p>Furnished:</p> <p>Number:</p> <p>Recommended Size:</p> <p><b>PREFILTERS</b></p> <p>Furnished:</p> <p>Number:</p> <p>Recommended Size:</p>

Notes:

- LOAD 1=Current of the largest motor (compressor or fan motor); LOAD 2=Sum of the currents of all remaining motors; LOAD 3 =Current of electric heaters  
LOAD 4 =Control Power Transformer (20-40 and 24-48 ton units add 3 FL amps for wire sizing formula, 50-75 and 59 - 89 ton units add 6 FL amps)
- For Electric Heat MCA, MOP, RDE values, calculate for both cooling and heating modes. (When determining LOADS, the compressors do not operate when the unit is in heating mode) (On 70-89 ton single source units, heating Load 4 = 12 amps on 200,230 volt units and 9 amps on 460,575 volt units)
- If selected Max Over Cur is less than the Min Cir Amp, then select the lowest maximum fuse size which is equal to or larger than the Min Cir Amp, provided the selected fuse size does not exceed 800 amps.
- If the selected Recommended Dual Element fuse size is greater than the selected Max Over Cur Protection value, then select the Recommended Dual Element fuse size value to equal the Max Over Protection value.
- Compressor KW at AHRI rating conditions of 80/67 -95
- Refrigerant charge is an approx. value. For a more precise value, see unit nameplate and service instructions.
- Sump Heater is an optional feature.
- Total Horsepower is the combined Horsepower for the Supply Fan Motors.

**Unit Dimensions - Commercial Rooftop Air Conditioning Units (Midrange)**

Item: A8 Qty: 1 Tag(s): RTU-4S

**ELECTRICAL / GENERAL DATA**

<p><b>TONS</b></p> <p>Model (Tonnage): SAHLF70 (70Ton)                  Unit Operating Voltage Range: 414-506                  Unit Primary Voltage: 460                  Unit Hertz: 60                  Unit Phase: 3</p> <p>EER: 10.1 EER                  IEER: 16.9 EER</p>	<p><b>GAS HEATING - PERFORMANCE</b></p> <p>Heating Input:                  Heating Output:                  Capacity Steps:</p> <p><b>HEATING - GENERAL DATA</b>                  Gas inlet pressure: (in w.c.)                  Gas Pipe Connection Size:</p>
<p><b>COMPRESSOR</b></p> <p>Compressor 1 Count: 1.00 Each                  Compressor 1 RLA: 25.40 A                  Compressor 2 Count: 1.00 Each                  Compressor 2 RLA: 37.20 A                  Compressor 3 Count: 1.00 Each                  Compressor 3 RLA: 38.90 A</p>	<p><b>ELECTRIC HEATER</b></p> <p>Electric Heater Kw:                  Electric Heater Full Load Amps:</p>
<p><b>SUPPLY FAN MOTOR</b></p> <p>Number of Fans: 2.00 Each                  Number of Motors: 2                  Total Horsepower: (8) 20 hp DDP 120% width                  Supply Fan Motor Full Load Amps: 14.30 A                  Supply Fan Efficiency: 66.92 %</p>	<p><b>EXHAUST / RETURN FAN MOTOR SECTION</b></p> <p>Number: Value not available                  Horsepower (Each): 100% Exhaust - 5 hp with Statitrac building pressure control                  Exhaust/Return Fan Motor FLA: 6.60 A</p>
<p><b>CONDENSER FAN MOTOR</b></p> <p>Number: 6                  Horsepower (each): 1.0                  Condenser Fan Motor Full Load Amps (Total): 10.8</p>	<p><b>FILTERS - TYPE</b></p> <p>Type:                  Furnished: YES                  Number: 35                  Recommended Size: 16" x20" x2"</p>
<p><b>EVAPORATIVE CONDENSER (7)</b></p> <p>Pump Horsepower: N/A                  Pump Full Load Amps: N/A                  Sump Heater Full Load Amps: N/A                  Sump Heater kW: N/A</p>	<p><b>PREFILTERS</b></p> <p>Furnished:                  Number:                  Recommended Size:</p>
<p><b>REFRIGERANT TYPE (6)</b></p> <p>Charge Type: R-410A                  Factory Charge (Circuit #1): 41.8 lb                  Factory Charge (Circuit #2): 45.0 lb</p>	<p><b>FINAL FILTERS - TYPE</b></p> <p>Type:                  Furnished:                  Number:                  Recommended Size:</p> <p><b>PREFILTERS</b></p> <p>Furnished:                  Number:                  Recommended Size:</p>

Notes:

- LOAD 1=Current of the largest motor (compressor or fan motor); LOAD 2=Sum of the currents of all remaining motors; LOAD 3 =Current of electric heaters  
 LOAD 4 =Control Power Transformer (20-40 and 24-48 ton units add 3 FL amps for wire sizing formula, 50-75 and 59 - 89 ton units add 6 FL amps)
- For Electric Heat MCA, MOP, RDE values, calculate for both cooling and heating modes. (When determining LOADS, the compressors do not operate when the unit is in heating mode) (On 70-89 ton single source units, heating Load 4 = 12 amps on 200,230 volt units and 9 amps on 460,575 volt units)
- If selected Max Over Cur is less than the Min Cir Amp, then select the lowest maximum fuse size which is equal to or larger than the Min Cir Amp, provided the selected fuse size does not exceed 800 amps.
- If the selected Recommended Dual Element fuse size is greater than the selected Max Over Cur Protection value, then select the Recommended Dual Element fuse size value to equal the Max Over Protection value.
- Compressor KW at AHRI rating conditions of 80/67 -95
- Refrigerant charge is an approx. value. For a more precise value, see unit nameplate and service instructions.
- Sump Heater is an optional feature.
- Total Horsepower is the combined Horsepower for the Supply Fan Motors.

**Unit Dimensions - Commercial Rooftop Air Conditioning Units (Midrange)**

Item: A9 Qty: 1 Tag(s): RTU-5N

**ELECTRICAL / GENERAL DATA**

<p><b>TONS</b></p> <p>Model (Tonnage): SAHLF75 (75Ton)</p> <p>Unit Operating Voltage Range: 414-506</p> <p>Unit Primary Voltage: 460</p> <p>Unit Hertz: 60</p> <p>Unit Phase: 3</p> <p>EER: 9.9 EER</p> <p>IEER: 17.3 EER</p>	<p><b>GAS HEATING - PERFORMANCE</b></p> <p>Heating Input:</p> <p>Heating Output:</p> <p>Capacity Steps:</p> <p><b>HEATING - GENERAL DATA</b></p> <p>Gas inlet pressure: (in w.c.)</p> <p>Gas Pipe Connection Size:</p>
<p><b>COMPRESSOR</b></p> <p>Compressor 1 Count: 1.00 Each</p> <p>Compressor 1 RLA: 38.90 A</p> <p>Compressor 2 Count: 2.00 Each</p> <p>Compressor 2 RLA: 25.40 A</p> <p>Compressor 3 Count: 1.00 Each</p> <p>Compressor 3 RLA: 37.20 A</p>	<p><b>ELECTRIC HEATER</b></p> <p>Electric Heater Kw:</p> <p>Electric Heater Full Load Amps:</p>
<p><b>SUPPLY FAN MOTOR</b></p> <p>Number of Fans: 2.00 Each</p> <p>Number of Motors: 2</p> <p>Total Horsepower: (8) 30 hp DDP 120% width</p> <p>Supply Fan Motor Full Load Amps: 20.50 A</p> <p>Supply Fan Efficiency: 64.58 %</p>	<p><b>EXHAUST / RETURN FAN MOTOR SECTION</b></p> <p>Number: Value not available</p> <p>Horsepower (Each): 100% Exhaust - 5 hp with Statitrac building pressure control</p> <p>Exhaust/Return Fan Motor FLA: 6.60 A</p>
<p><b>CONDENSER FAN MOTOR</b></p> <p>Number: 6</p> <p>Horsepower (each): 1.0</p> <p>Condenser Fan Motor Full Load Amps (Total): 10.8</p>	<p><b>FILTERS - TYPE</b></p> <p>Type:</p> <p>Furnished: YES</p> <p>Number: 35</p> <p>Recommended Size: 16" x20" x2"</p>
<p><b>EVAPORATIVE CONDENSER (7)</b></p> <p>Pump Horsepower: N/A</p> <p>Pump Full Load Amps: N/A</p> <p>Sump Heater Full Load Amps: N/A</p> <p>Sump Heater kW: N/A</p>	<p><b>PREFILTERS</b></p> <p>Furnished:</p> <p>Number:</p> <p>Recommended Size:</p>
<p><b>REFRIGERANT TYPE (6)</b></p> <p>Charge Type: R-410A</p> <p>Factory Charge (Circuit #1): 48.8 lb</p> <p>Factory Charge (Circuit #2): 45.3 lb</p>	<p><b>FINAL FILTERS - TYPE</b></p> <p>Type:</p> <p>Furnished:</p> <p>Number:</p> <p>Recommended Size:</p> <p><b>PREFILTERS</b></p> <p>Furnished:</p> <p>Number:</p> <p>Recommended Size:</p>

Notes:

- LOAD 1=Current of the largest motor (compressor or fan motor); LOAD 2=Sum of the currents of all remaining motors; LOAD 3 =Current of electric heaters  
LOAD 4 =Control Power Transformer (20-40 and 24-48 ton units add 3 FL amps for wire sizing formula, 50-75 and 59 - 89 ton units add 6 FL amps)
- For Electric Heat MCA, MOP, RDE values, calculate for both cooling and heating modes. (When determining LOADS, the compressors do not operate when the unit is in heating mode) (On 70-89 ton single source units, heating Load 4 = 12 amps on 200,230 volt units and 9 amps on 460,575 volt units)
- If selected Max Over Cur is less than the Min Cir Amp, then select the lowest maximum fuse size which is equal to or larger than the Min Cir Amp, provided the selected fuse size does not exceed 800 amps.
- If the selected Recommended Dual Element fuse size is greater than the selected Max Over Cur Protection value, then select the Recommended Dual Element fuse size value to equal the Max Over Protection value.
- Compressor KW at AHRI rating conditions of 80/67 -95
- Refrigerant charge is an approx. value. For a more precise value, see unit nameplate and service instructions.
- Sump Heater is an optional feature.
- Total Horsepower is the combined Horsepower for the Supply Fan Motors.

**Unit Dimensions - Commercial Rooftop Air Conditioning Units (Midrange)**

Item: A10 Qty: 1 Tag(s): RTU-5S

**ELECTRICAL / GENERAL DATA**

<p><b>TONS</b></p> <p>Model (Tonnage): SAHLF75 (75Ton)</p> <p>Unit Operating Voltage Range: 414-506</p> <p>Unit Primary Voltage: 460</p> <p>Unit Hertz: 60</p> <p>Unit Phase: 3</p> <p>EER: 9.9 EER</p> <p>IEER: 17.3 EER</p>	<p><b>GAS HEATING - PERFORMANCE</b></p> <p>Heating Input:</p> <p>Heating Output:</p> <p>Capacity Steps:</p> <p><b>HEATING - GENERAL DATA</b></p> <p>Gas inlet pressure: (in w.c.)</p> <p>Gas Pipe Connection Size:</p>
<p><b>COMPRESSOR</b></p> <p>Compressor 1 Count: 1.00 Each</p> <p>Compressor 1 RLA: 38.90 A</p> <p>Compressor 2 Count: 2.00 Each</p> <p>Compressor 2 RLA: 25.40 A</p> <p>Compressor 3 Count: 1.00 Each</p> <p>Compressor 3 RLA: 37.20 A</p>	<p><b>ELECTRIC HEATER</b></p> <p>Electric Heater Kw:</p> <p>Electric Heater Full Load Amps:</p>
<p><b>SUPPLY FAN MOTOR</b></p> <p>Number of Fans: 2.00 Each</p> <p>Number of Motors: 2</p> <p>Total Horsepower: (8) 30 hp DDP 120% width</p> <p>Supply Fan Motor Full Load Amps: 20.50 A</p> <p>Supply Fan Efficiency: 64.71 %</p>	<p><b>EXHAUST / RETURN FAN MOTOR SECTION</b></p> <p>Number: Value not available</p> <p>Horsepower (Each): 100% Exhaust - 5 hp with Statitrac building pressure control</p> <p>Exhaust/Return Fan Motor FLA: 6.60 A</p>
<p><b>CONDENSER FAN MOTOR</b></p> <p>Number: 6</p> <p>Horsepower (each): 1.0</p> <p>Condenser Fan Motor Full Load Amps (Total): 10.8</p>	<p><b>FILTERS - TYPE</b></p> <p>Type:</p> <p>Furnished: YES</p> <p>Number: 35</p> <p>Recommended Size: 16" x20" x2"</p>
<p><b>EVAPORATIVE CONDENSER (7)</b></p> <p>Pump Horsepower: N/A</p> <p>Pump Full Load Amps: N/A</p> <p>Sump Heater Full Load Amps: N/A</p> <p>Sump Heater kW: N/A</p>	<p><b>PREFILTERS</b></p> <p>Furnished:</p> <p>Number:</p> <p>Recommended Size:</p>
<p><b>REFRIGERANT TYPE (6)</b></p> <p>Charge Type: R-410A</p> <p>Factory Charge (Circuit #1): 48.8 lb</p> <p>Factory Charge (Circuit #2): 45.3 lb</p>	<p><b>FINAL FILTERS - TYPE</b></p> <p>Type:</p> <p>Furnished:</p> <p>Number:</p> <p>Recommended Size:</p> <p><b>PREFILTERS</b></p> <p>Furnished:</p> <p>Number:</p> <p>Recommended Size:</p>

Notes:

- LOAD 1=Current of the largest motor (compressor or fan motor); LOAD 2=Sum of the currents of all remaining motors; LOAD 3 =Current of electric heaters  
LOAD 4 =Control Power Transformer (20-40 and 24-48 ton units add 3 FL amps for wire sizing formula, 50-75 and 59 - 89 ton units add 6 FL amps)
- For Electric Heat MCA, MOP, RDE values, calculate for both cooling and heating modes. (When determining LOADS, the compressors do not operate when the unit is in heating mode) (On 70-89 ton single source units, heating Load 4 = 12 amps on 200,230 volt units and 9 amps on 460,575 volt units)
- If selected Max Over Cur is less than the Min Cir Amp, then select the lowest maximum fuse size which is equal to or larger than the Min Cir Amp, provided the selected fuse size does not exceed 800 amps.
- If the selected Recommended Dual Element fuse size is greater than the selected Max Over Cur Protection value, then select the Recommended Dual Element fuse size value to equal the Max Over Protection value.
- Compressor KW at AHRI rating conditions of 80/67 -95
- Refrigerant charge is an approx. value. For a more precise value, see unit nameplate and service instructions.
- Sump Heater is an optional feature.
- Total Horsepower is the combined Horsepower for the Supply Fan Motors.

### Fan Curve - Commercial Rooftop Air Conditioning Units (Midrange)

Item: A1 Qty: 1 Tag(s): RTU-1N

2-2509DPLA01FN

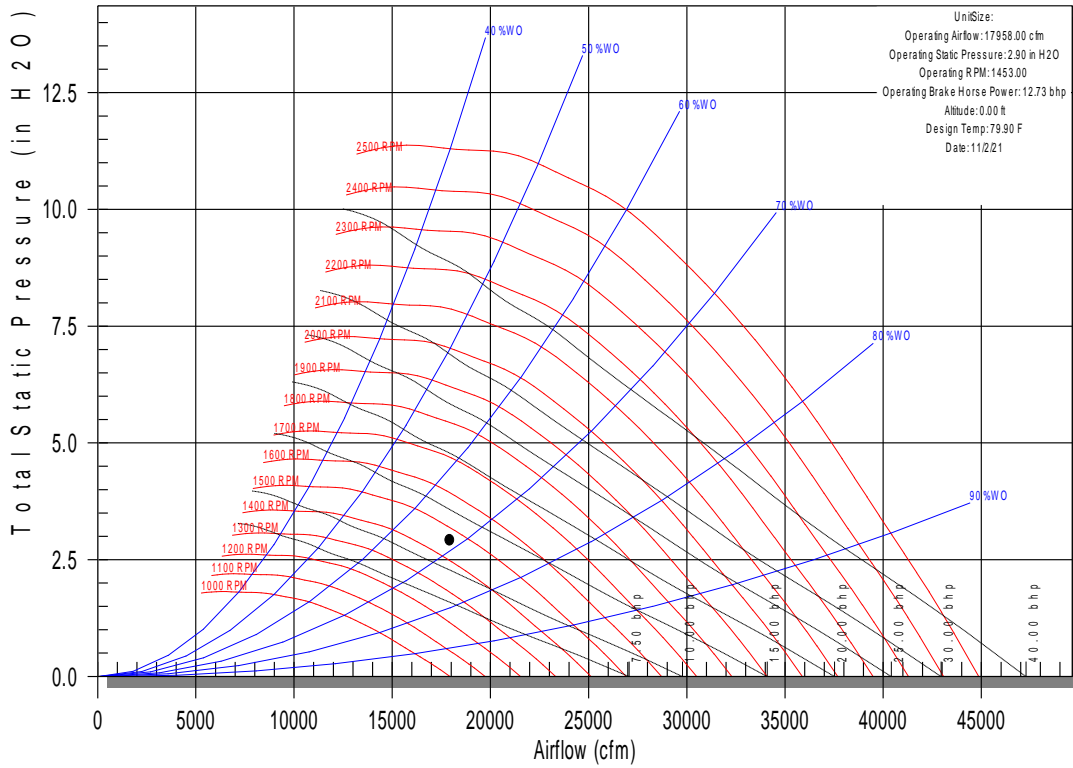

R03

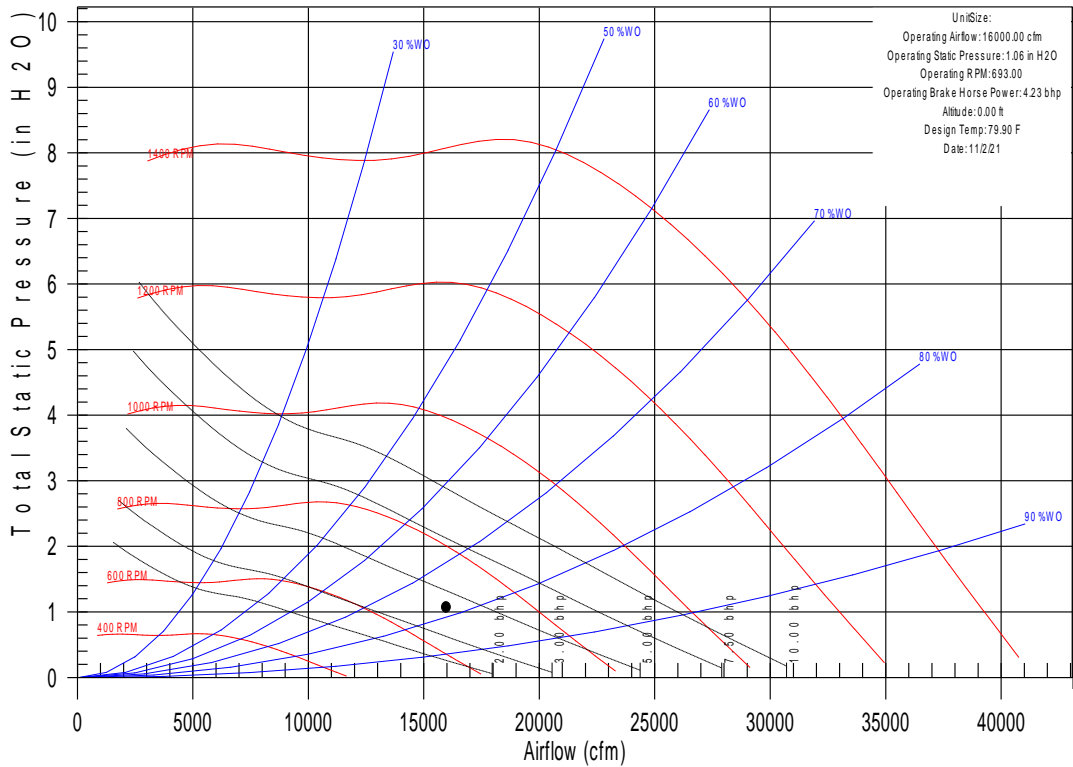

### Fan Curve - Commercial Rooftop Air Conditioning Units (Midrange)

Item: A2 Qty: 1 Tag(s): RTU-1S

2-2710DPLA01FN

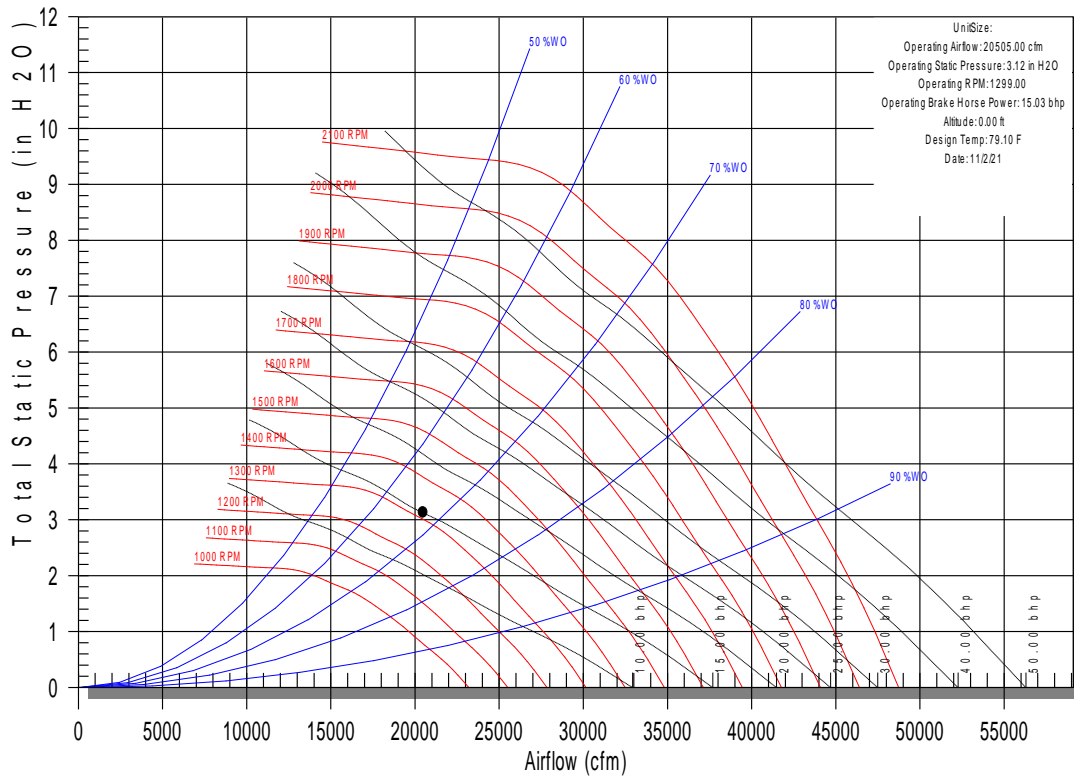

R03

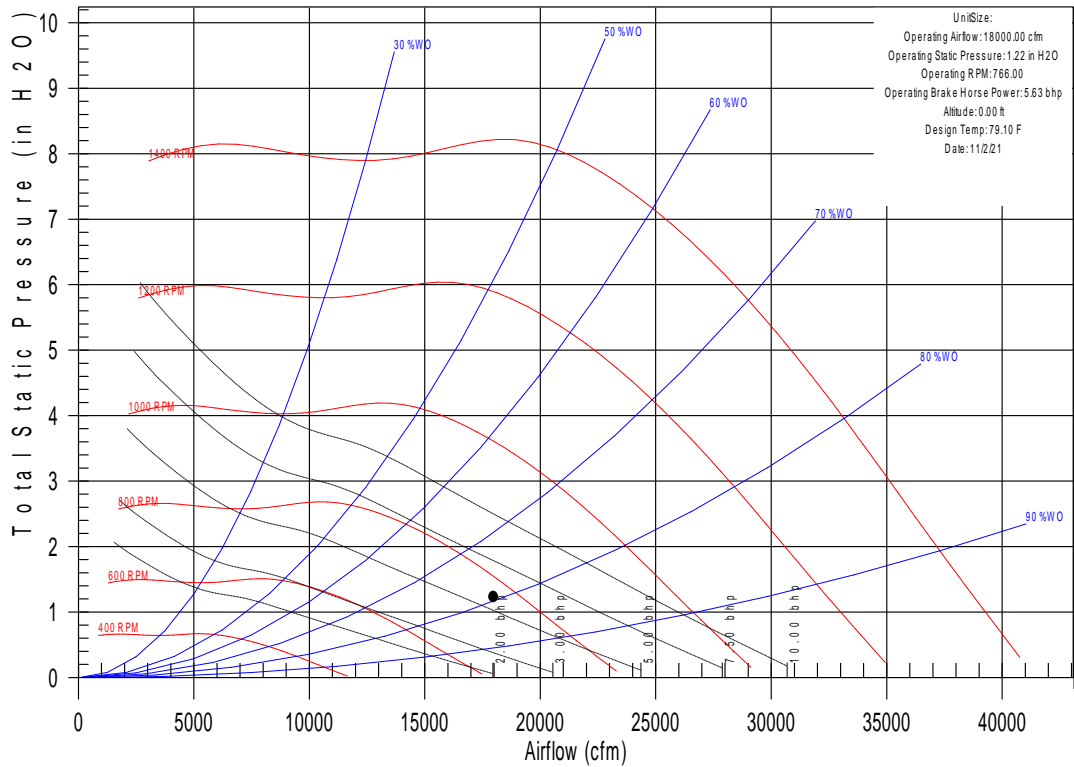

Fan Curve - Commercial Rooftop Air Conditioning Units (Midrange)

Item: A3 Qty: 1 Tag(s): RTU-2N

2-2707DPLA01FN

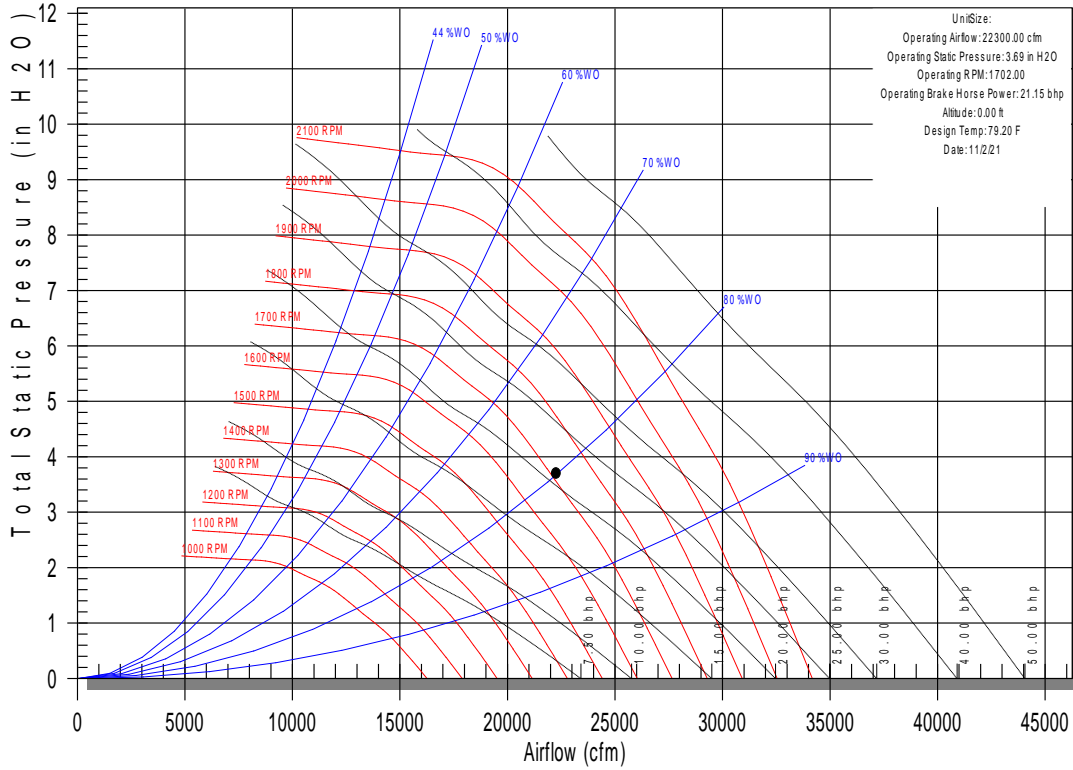

	63Hz	125Hz	250Hz	500Hz	1 kHz	2 kHz	4 kHz	8 kHz
Outdoor Noise:	101	96	93	92	89	86	83	79
Supply Duct:	89	86	91	86	83	75	71	65
Return Duct:	89	80	91	76	70	67	64	68

Fan Curve - Commercial Rooftop Air Conditioning Units (Midrange)

Item: A4 Qty: 1 Tag(s): RTU-2S

2-2707DPLA01FN

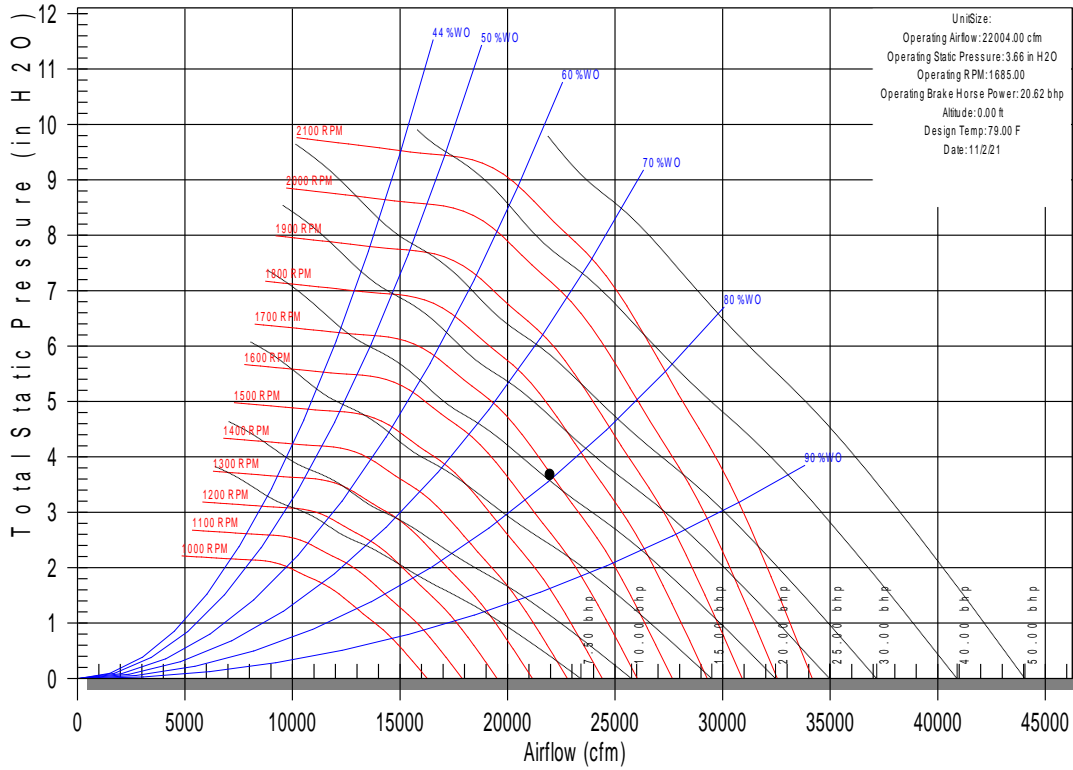

	63Hz	125Hz	250Hz	500Hz	1 kHz	2 kHz	4 kHz	8 kHz
Outdoor Noise:	101	96	93	92	89	86	83	79
Supply Duct:	89	85	91	86	82	75	70	65
Return Duct:	88	80	91	76	70	67	64	68

Fan Curve - Commercial Rooftop Air Conditioning Units (Midrange)

Item: A5 Qty: 1 Tag(s): RTU-3N

2-2710DPLA01FN

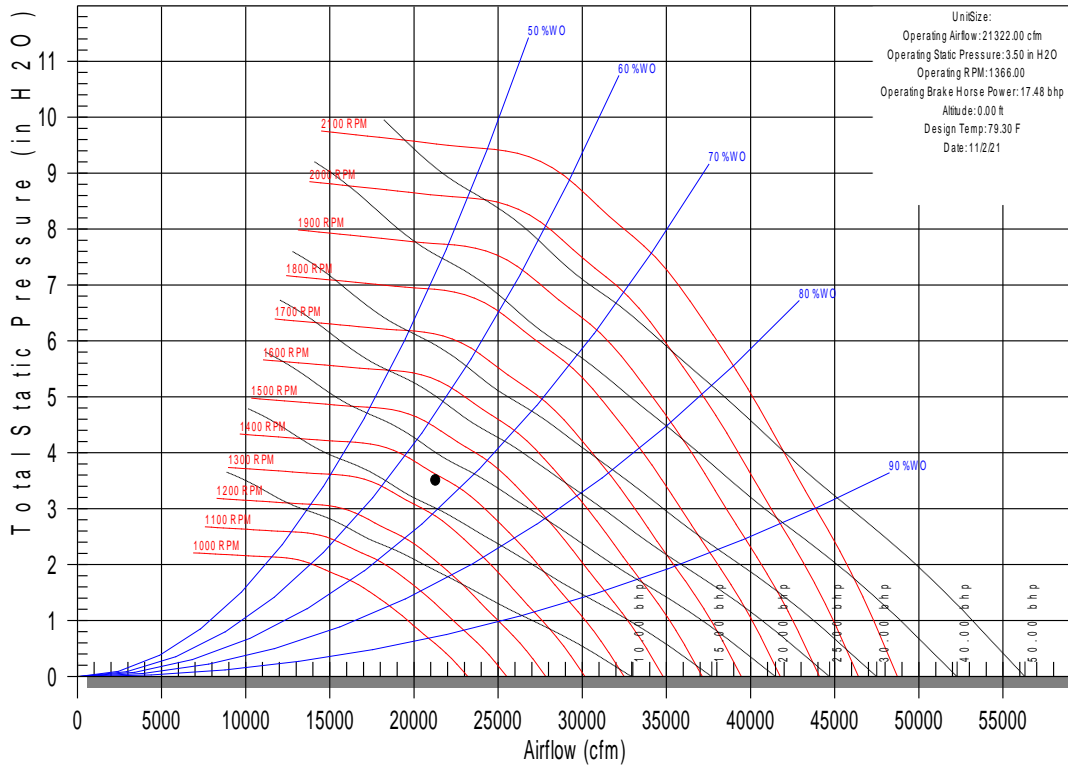

	63Hz	125Hz	250Hz	500Hz	1 kHz	2 kHz	4 kHz	8 kHz
Outdoor Noise:	-1	-1	-1	-1	-1	-1	-1	-1
Supply Duct:	-1	-1	-1	-1	-1	-1	-1	-1
Return Duct:	-1	-1	-1	-1	-1	-1	-1	-1

Fan Curve - Commercial Rooftop Air Conditioning Units (Midrange)

Item: A6 Qty: 1 Tag(s): RTU-3S

2-2710DPLA01FN

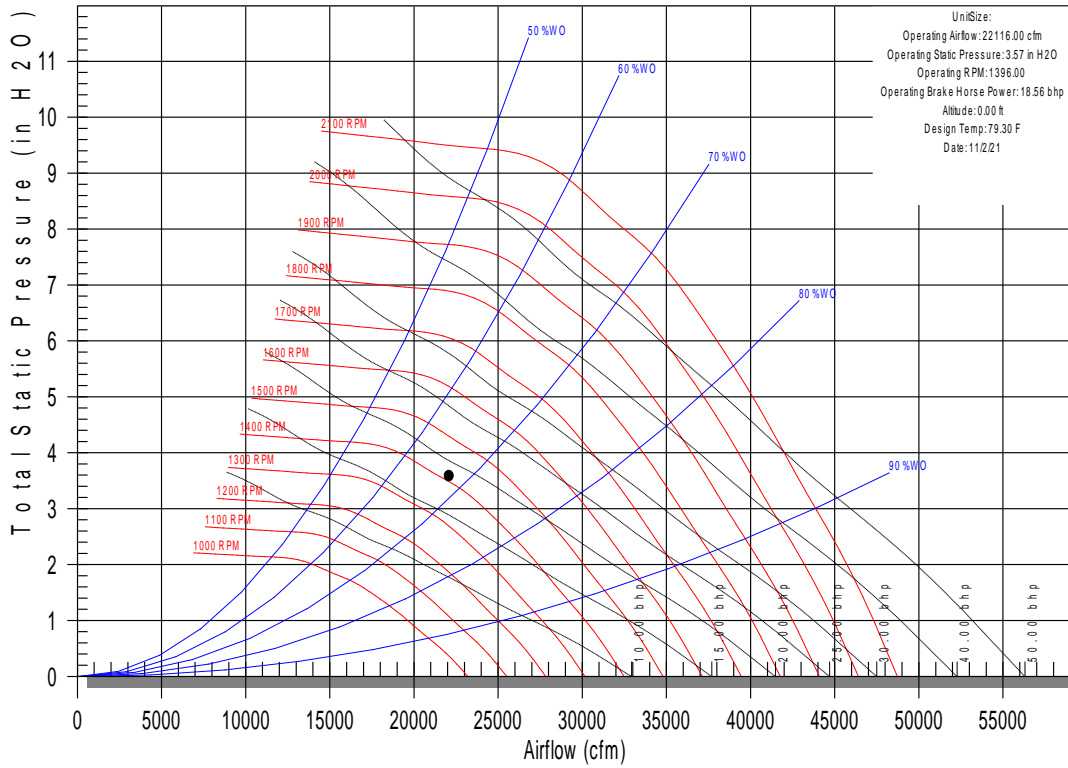

	63Hz	125Hz	250Hz	500Hz	1 kHz	2 kHz	4 kHz	8 kHz
Outdoor Noise:	-1	-1	-1	-1	-1	-1	-1	-1
Supply Duct:	-1	-1	-1	-1	-1	-1	-1	-1
Return Duct:	-1	-1	-1	-1	-1	-1	-1	-1

Fan Curve - Commercial Rooftop Air Conditioning Units (Midrange)

Item: A7 Qty: 1 Tag(s): RTU-4N

2-2710DPLA01FN

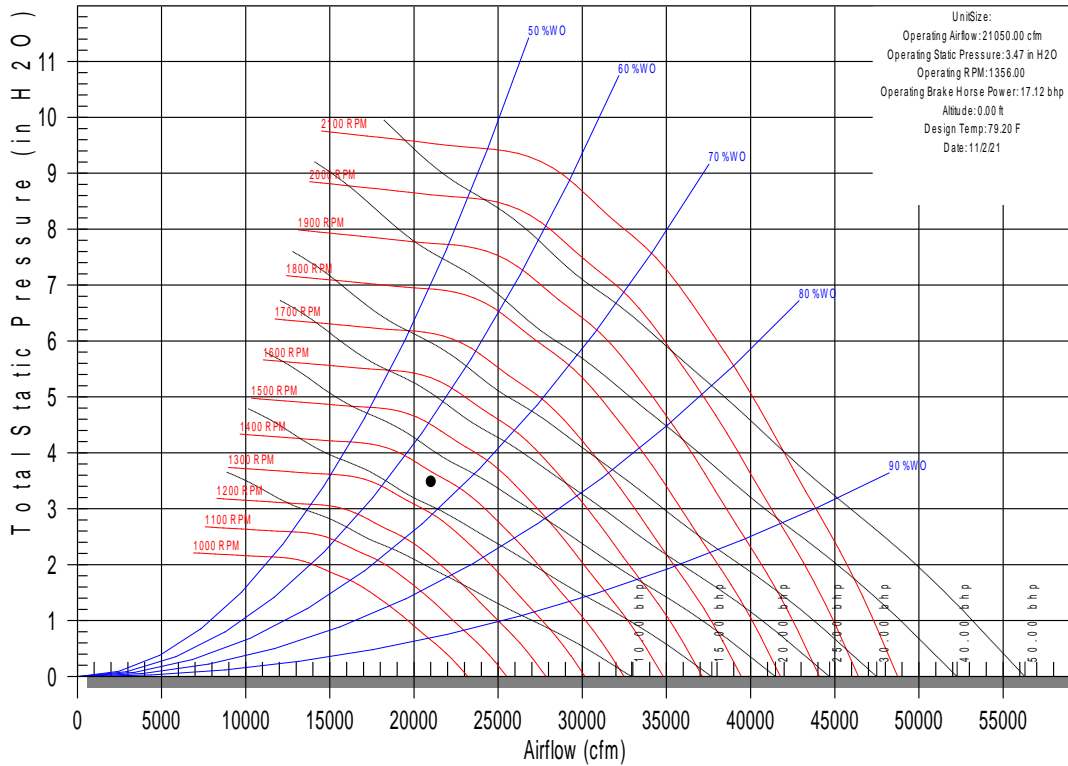

	63Hz	125Hz	250Hz	500Hz	1 kHz	2 kHz	4 kHz	8 kHz
Outdoor Noise:	-1	-1	-1	-1	-1	-1	-1	-1
Supply Duct:	-1	-1	-1	-1	-1	-1	-1	-1
Return Duct:	-1	-1	-1	-1	-1	-1	-1	-1

Fan Curve - Commercial Rooftop Air Conditioning Units (Midrange)

Item: A8 Qty: 1 Tag(s): RTU-4S

2-2710DPLA01FN

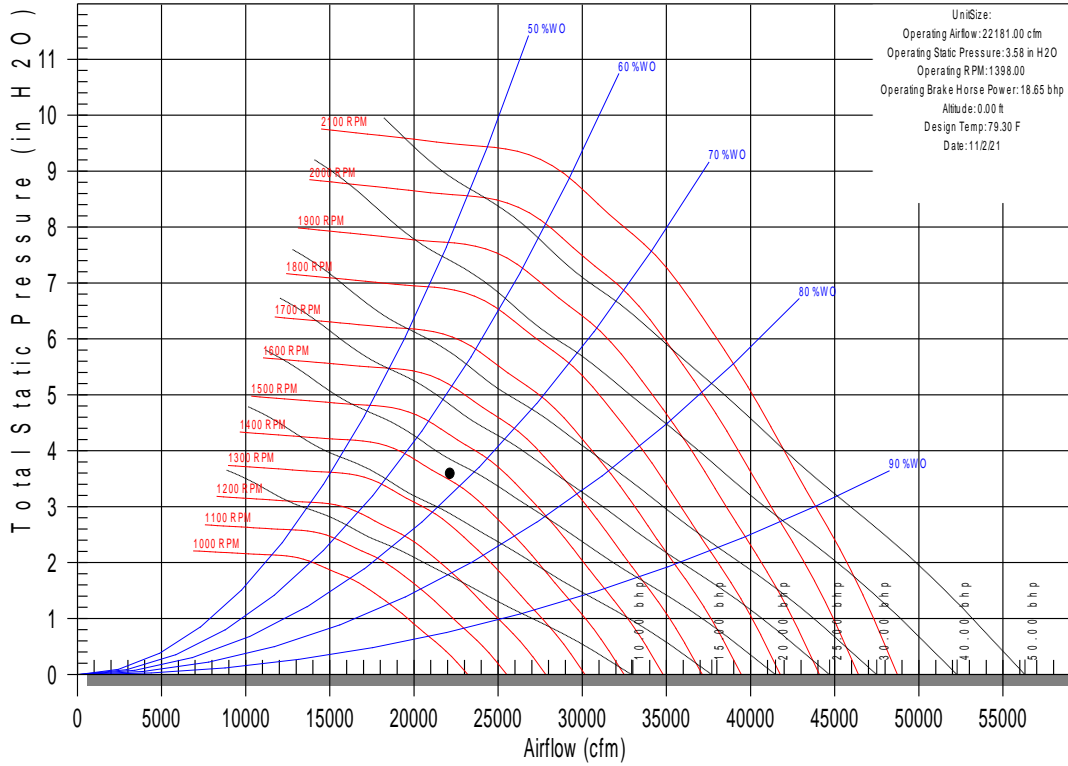

	63Hz	125Hz	250Hz	500Hz	1 kHz	2 kHz	4 kHz	8 kHz
Outdoor Noise:	-1	-1	-1	-1	-1	-1	-1	-1
Supply Duct:	-1	-1	-1	-1	-1	-1	-1	-1
Return Duct:	-1	-1	-1	-1	-1	-1	-1	-1

Fan Curve - Commercial Rooftop Air Conditioning Units (Midrange)

Item: A9 Qty: 1 Tag(s): RTU-5N

2-2710DPLA01FN

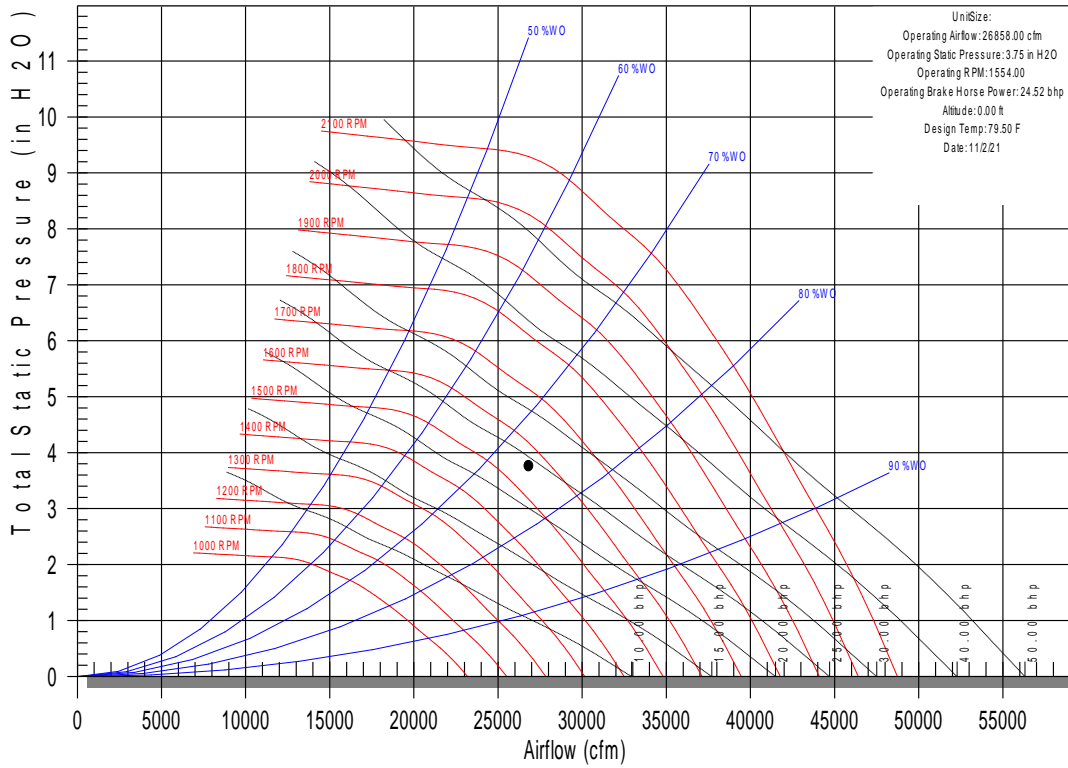

	63Hz	125Hz	250Hz	500Hz	1 kHz	2 kHz	4 kHz	8 kHz
Outdoor Noise:	-1	-1	-1	-1	-1	-1	-1	-1
Supply Duct:	-1	-1	-1	-1	-1	-1	-1	-1
Return Duct:	-1	-1	-1	-1	-1	-1	-1	-1

Fan Curve - Commercial Rooftop Air Conditioning Units (Midrange)

Item: A10 Qty: 1 Tag(s): RTU-5S

2-2710DPLA01FN

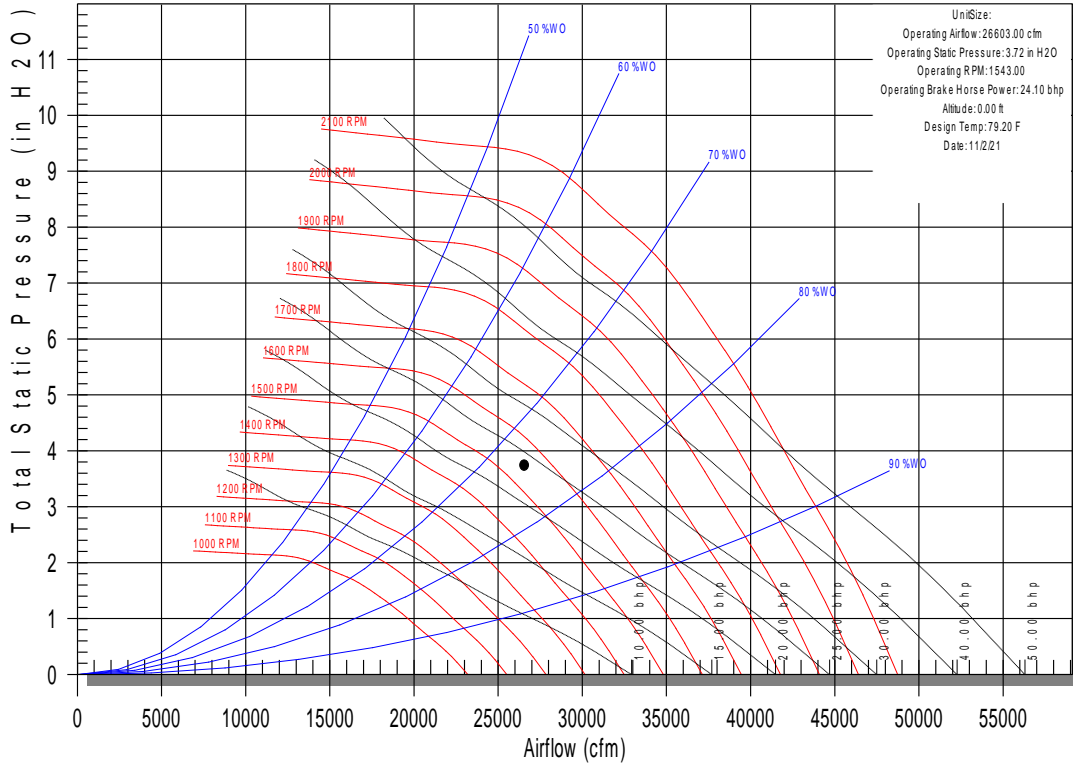

	63Hz	125Hz	250Hz	500Hz	1 kHz	2 kHz	4 kHz	8 kHz
Outdoor Noise:	-1	-1	-1	-1	-1	-1	-1	-1
Supply Duct:	-1	-1	-1	-1	-1	-1	-1	-1
Return Duct:	-1	-1	-1	-1	-1	-1	-1	-1

**Weight, Clearance & Rigging Diagram - Commercial Rooftop Air Conditioning Units (Midrange)**

Item: A1 - A10 Qty: 10 Tag(s): RTU-1N, RTU-1S, RTU-2N, RTU-2S, RTU-3N, RTU-3S, RTU-4N, RTU-4S, RTU-5N, RTU-5S

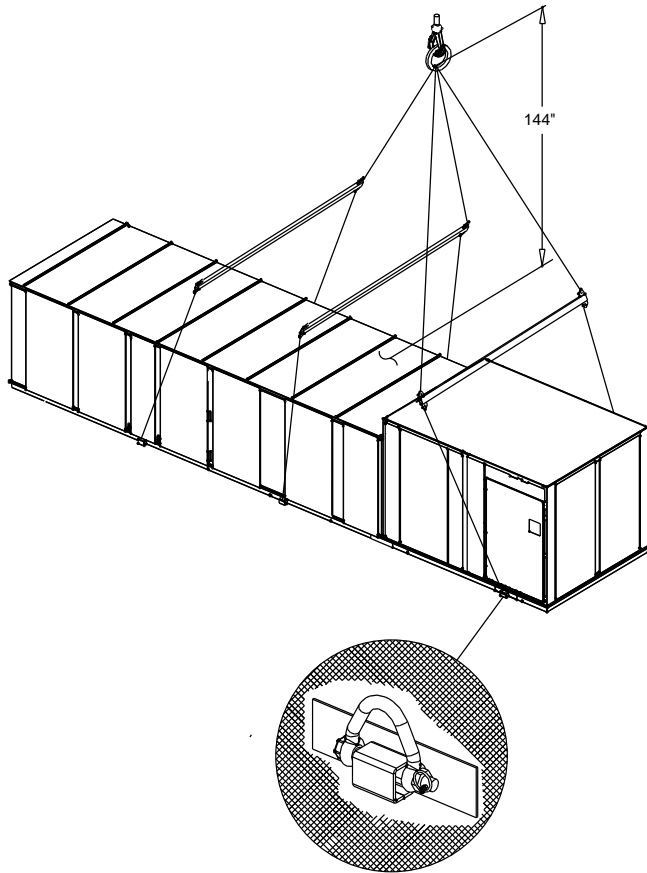

Note:  
 When 2 or more units are to be placed side by side, the distance between the units should be increased to 150% of the recommended single unit clearance. The units should also be staggered to reduce span deflection & assure proper diffusion of exhaust air.

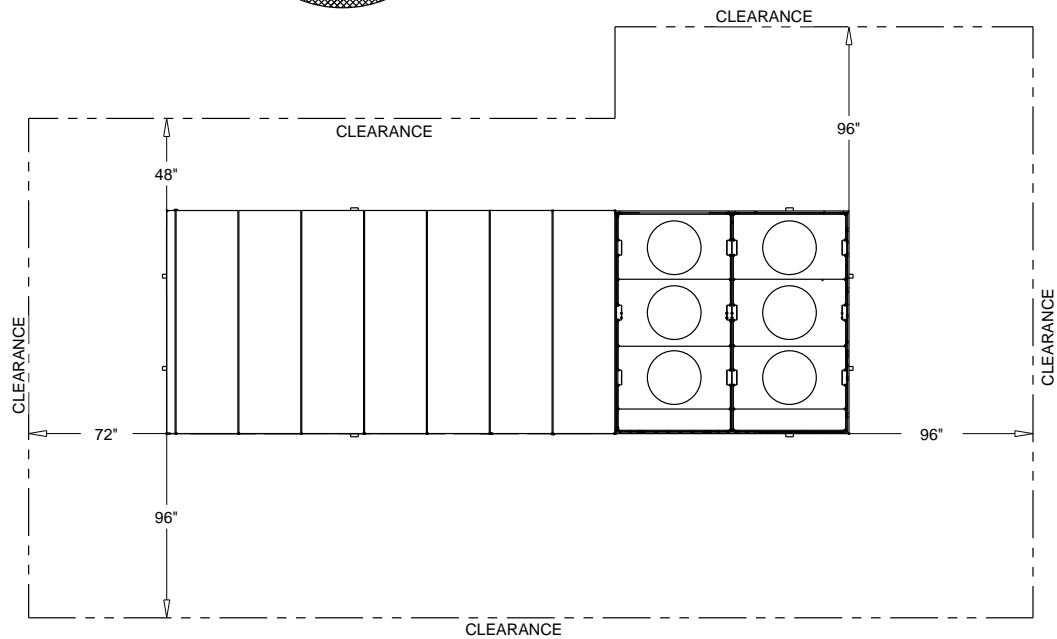
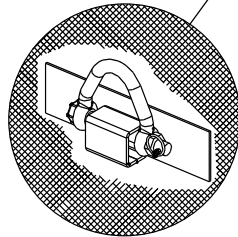

**RIGGING AND CLEARANCE**  
 AIR COOLED DRAWING

**Weight, Clearance & Rigging Diagram - Commercial Rooftop Air Conditioning Units (Midrange)**

Item: A1 Qty: 1 Tag(s): RTU-1N

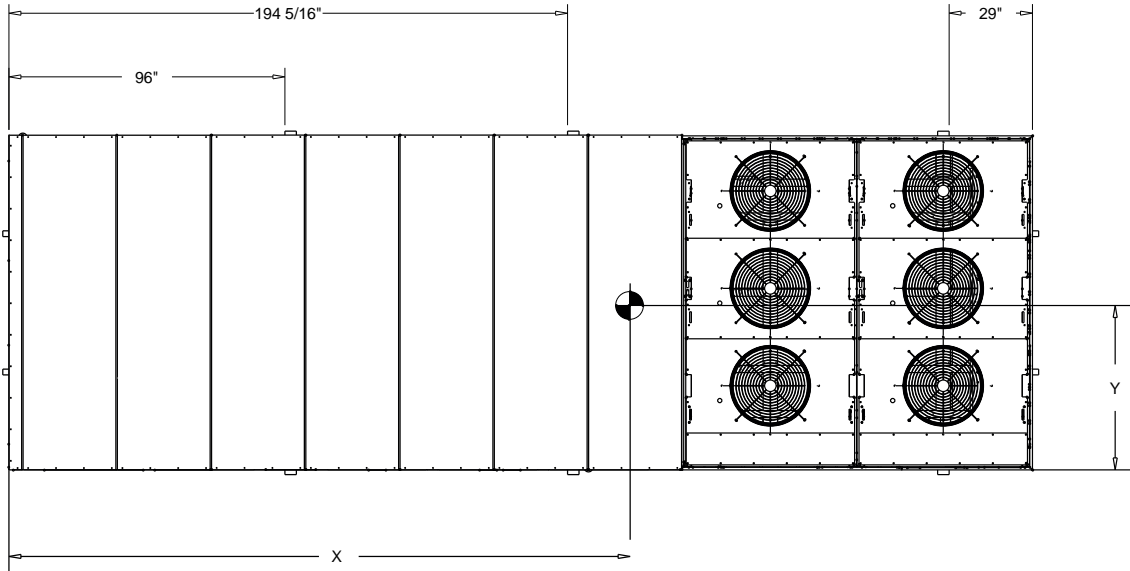

Center of Gravity X:	15.23 ft	Point load X location 1:	4.000 in
Center of Gravity Y:	4.95 ft	Point load X location 2:	120.000 in
Point Load 1:	1109.8 lb	Point load X location 3:	236.000 in
Point Load 2:	1178.6 lb	Point load X location 4:	332.000 in
Point Load 3:	1206.2 lb	Point load X location 5:	N/A
Point Load 4:	1275.0 lb	Point load X location 6:	N/A
Point Load 5:	1302.6 lb	Point load X location 7:	N/A
Point Load 6:	1371.4 lb	Point load X location 8:	N/A
Point Load 7:	1382.3 lb	Point load Y location 1:	4.000 in
Point Load 8:	1451.1 lb	Point load Y location 2:	112.000 in
Total Weight:	10277.0 lb		

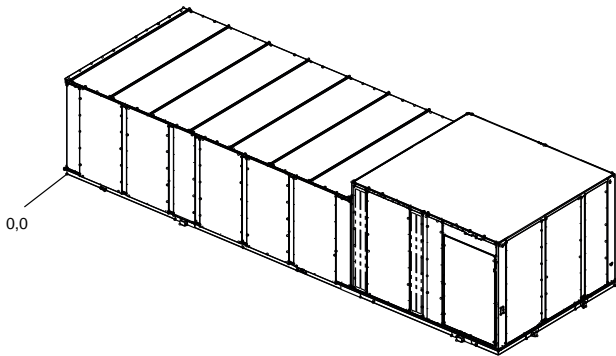

- Notes:
1. The actual weight is stamped on the unit nameplate.
  2. The weight shown represents the typical unit operating weight for the configuration selected. Estimated at +/- 10% of the nameplate weight.
  3. Design Special weights are not displayed. Any weight added through COD (Custom Order Design) will not be accounted in the +/- 10% estimate
  4. When 2 or more units are to be placed side by side, the distance between the units should be increased to 150% of the recommended single unit clearance. The units should also be staggered to reduce span deflection & assure proper diffusion of exhaust air.

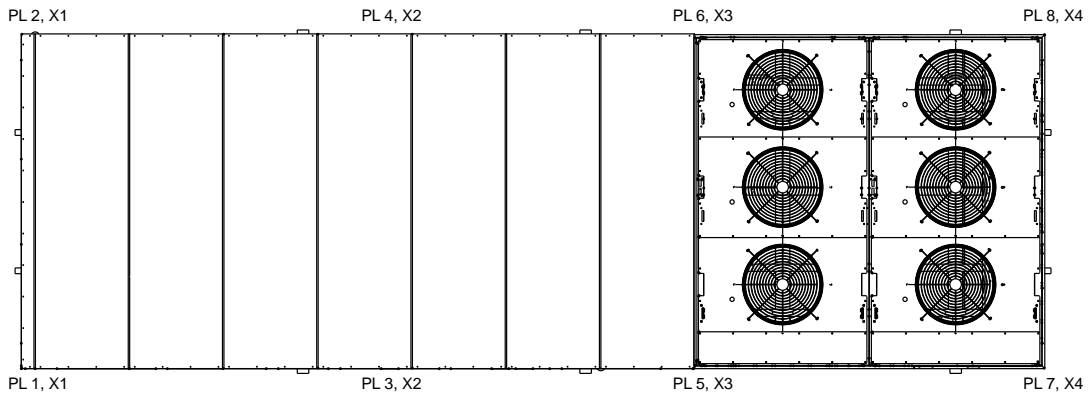

CENTER OF GRAVITY AND INSTALL WEIGHT X-Y POINTS  
AIR COOLED DRAWING

**Weight, Clearance & Rigging Diagram - Commercial Rooftop Air Conditioning Units (Midrange)**

Item: A2 Qty: 1 Tag(s): RTU-1S

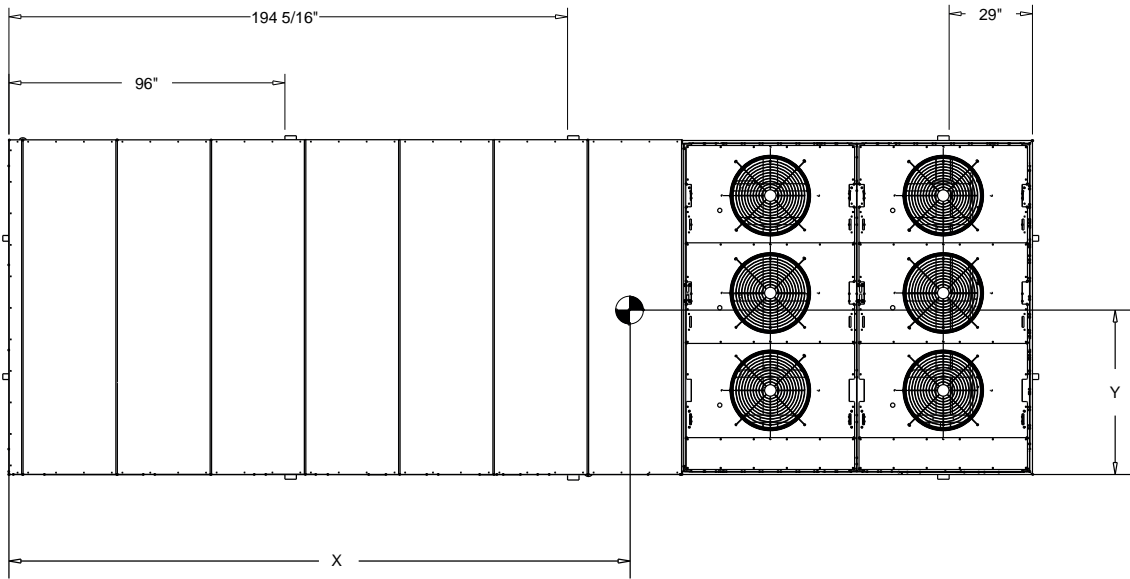

Center of Gravity X:	16.85 ft	Point load X location 1:	4.000 in
Center of Gravity Y:	5.06 ft	Point load X location 2:	101.000 in
Point Load 1:	880.3 lb	Point load X location 3:	187.000 in
Point Load 2:	992.1 lb	Point load X location 4:	274.000 in
Point Load 3:	980.1 lb	Point load X location 5:	370.000 in
Point Load 4:	1092.0 lb	Point load X location 6:	N/A
Point Load 5:	1068.7 lb	Point load X location 7:	N/A
Point Load 6:	1180.5 lb	Point load X location 8:	N/A
Point Load 7:	1158.2 lb	Point load X location 9:	N/A
Point Load 8:	1270.0 lb	Point load X location 10:	N/A
Point Load 9:	1257.0 lb	Point load Y location 1:	4.000 in
Point Load 10:	1368.8 lb	Point load Y location 2:	112.000 in
Total Weight:	11247.8 lb		

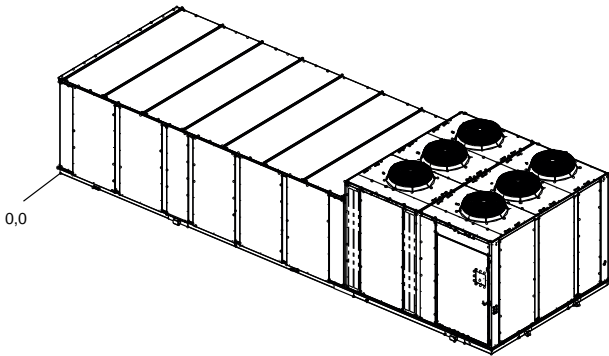

- Notes:
1. The actual weight is stamped on the unit nameplate.
  2. The weight shown represents the typical unit operating weight for the configuration selected. Estimated at +/- 10% of the nameplate weight.
  3. Design Special weights are not displayed. Any weight added through COD (Custom Order Design) will not be accounted in the +/- 10% estimate
  4. When 2 or more units are to be placed side by side, the distance between the units should be increased to 150% of the recommended single unit clearance. The units should also be staggered to reduce span deflection & assure proper diffusion of exhaust air.

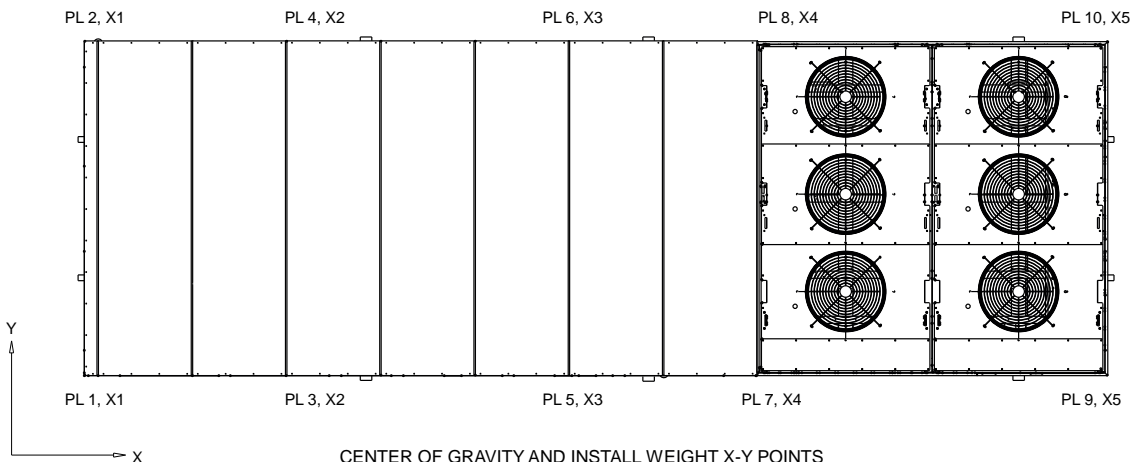

CENTER OF GRAVITY AND INSTALL WEIGHT X-Y POINTS  
AIR COOLED DRAWING

**Weight, Clearance & Rigging Diagram - Commercial Rooftop Air Conditioning Units (Midrange)**  
 Item: A3 - A8 Qty: 6 Tag(s): RTU-2N, RTU-2S, RTU-3N, RTU-3S, RTU-4N, RTU-4S

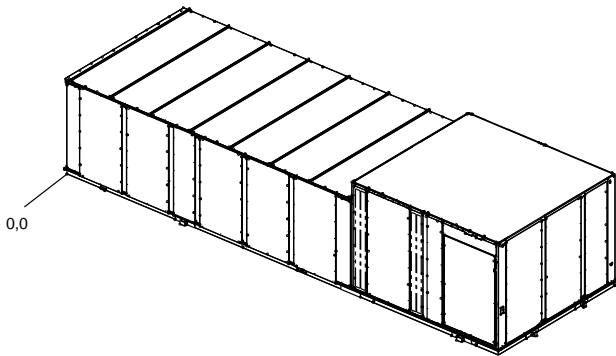
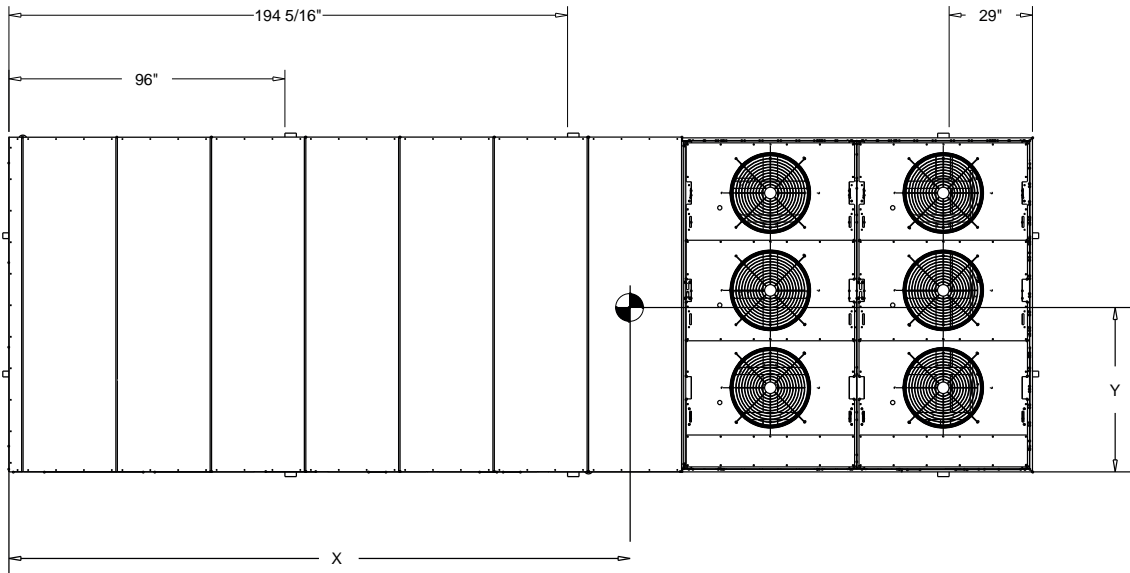

Center of Gravity X:	15.50 ft	Point load X location 1:	4.000 in
Center of Gravity Y:	4.99 ft	Point load X location 2:	120.000 in
Point Load 1:	1085.6 lb	Point load X location 3:	236.000 in
Point Load 2:	1180.5 lb	Point load X location 4:	332.000 in
Point Load 3:	1217.6 lb	Point load X location 5:	N/A
Point Load 4:	1312.5 lb	Point load X location 6:	N/A
Point Load 5:	1349.6 lb	Point load X location 7:	N/A
Point Load 6:	1444.5 lb	Point load X location 8:	N/A
Point Load 7:	1458.8 lb	Point load Y location 1:	4.000 in
Point Load 8:	1553.7 lb	Point load Y location 2:	112.000 in
Total Weight:	10602.8 lb		

- Notes:
1. The actual weight is stamped on the unit nameplate.
  2. The weight shown represents the typical unit operating weight for the configuration selected. Estimated at +/- 10% of the nameplate weight.
  3. Design Special weights are not displayed. Any weight added through COD (Custom Order Design) will not be accounted in the +/- 10% estimate
  4. When 2 or more units are to be placed side by side, the distance between the units should be increased to 150% of the recommended single unit clearance. The units should also be staggered to reduce span deflection & assure proper diffusion of exhaust air.

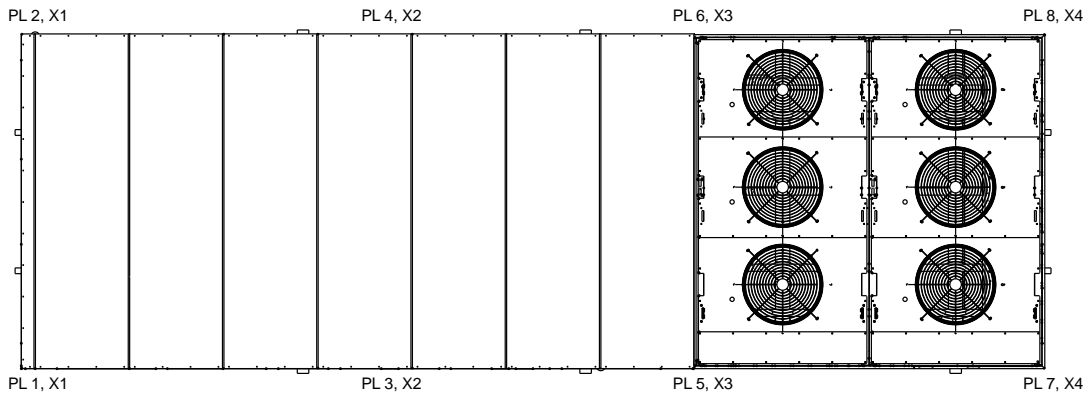

CENTER OF GRAVITY AND INSTALL WEIGHT X-Y POINTS  
 AIR COOLED DRAWING

**Weight, Clearance & Rigging Diagram - Commercial Rooftop Air Conditioning Units (Midrange)**

Item: A9, A10 Qty: 2 Tag(s): RTU-5N, RTU-5S

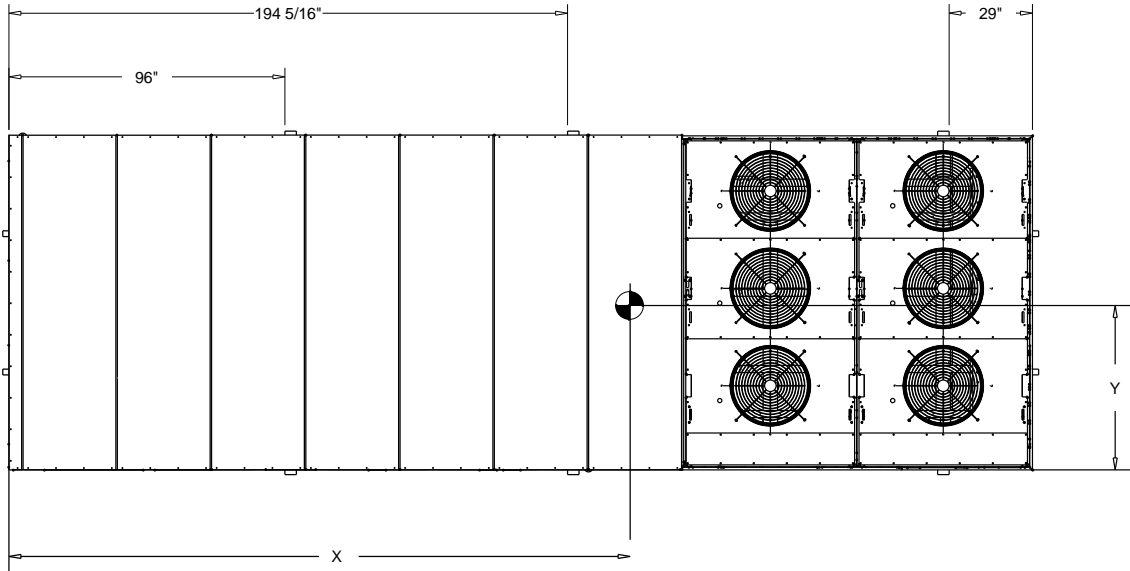

Center of Gravity X:	15.83 ft	Point load X location 1:	4.000 in
Center of Gravity Y:	4.96 ft	Point load X location 2:	120.000 in
Point Load 1:	1060.9 lb	Point load X location 3:	236.000 in
Point Load 2:	1136.5 lb	Point load X location 4:	332.000 in
Point Load 3:	1236.7 lb	Point load X location 5:	N/A
Point Load 4:	1312.4 lb	Point load X location 6:	N/A
Point Load 5:	1412.6 lb	Point load X location 7:	N/A
Point Load 6:	1488.2 lb	Point load X location 8:	N/A
Point Load 7:	1558.2 lb	Point load Y location 1:	4.000 in
Point Load 8:	1633.8 lb	Point load Y location 2:	112.000 in
<b>Total Weight:</b>	<b>10839.2 lb</b>		

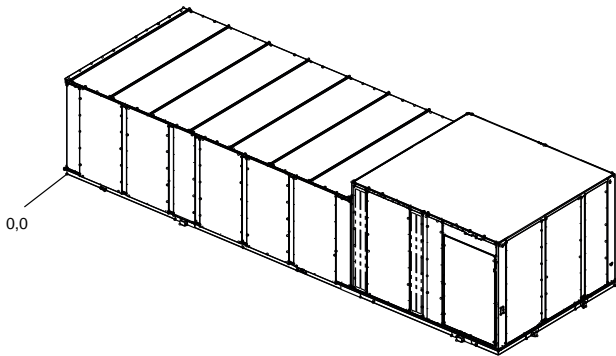

- Notes:
1. The actual weight is stamped on the unit nameplate.
  2. The weight shown represents the typical unit operating weight for the configuration selected. Estimated at +/- 10% of the nameplate weight.
  3. Design Special weights are not displayed. Any weight added through COD (Custom Order Design) will not be accounted in the +/- 10% estimate
  4. When 2 or more units are to be placed side by side, the distance between the units should be increased to 150% of the recommended single unit clearance. The units should also be staggered to reduce span deflection & assure proper diffusion of exhaust air.

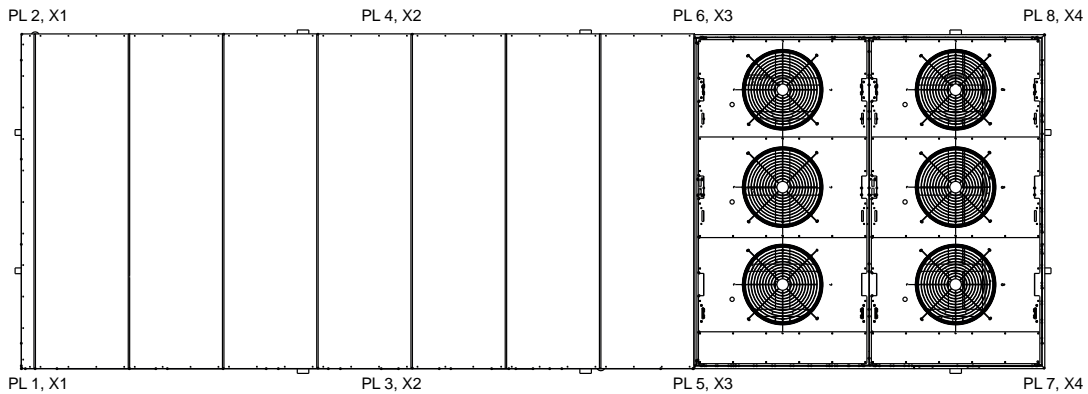

CENTER OF GRAVITY AND INSTALL WEIGHT X-Y POINTS  
AIR COOLED DRAWING

**Accessory - Commercial Rooftop Air Conditioning Units (Midrange)**

**Item: A1 - A10 Qty: 10 Tag(s): RTU-1N, RTU-1S, RTU-2N, RTU-2S, RTU-3N, RTU-3S, RTU-4N, RTU-4S, RTU-5N, RTU-5S**

<p><b>⚠ WARNING</b></p> <p><b>HAZARDOUS VOLTAGE!</b></p> <p>DISCONNECT ALL ELECTRIC POWER INCLUDING REMOTE DISCONNECTS AND FOLLOW LOCK OUT AND TAG PROCEDURES BEFORE SERVICING. INSURE THAT ALL MOTOR CAPACITORS HAVE DISCHARGED STORED VOLTAGE. UNITS WITH VARIABLE SPEED DRIVE, REFER TO DRIVE INSTRUCTIONS FOR CAPACITOR DISCHARGE.</p> <p>FAILURE TO DO THE ABOVE BEFORE SERVICING COULD RESULT IN DEATH OR SERIOUS INJURY.</p>	<p><b>⚠ AVERTISSEMENT</b></p> <p><b>TENSION DANGEREUSE!</b></p> <p>COUPER TOUTES LES TENSIONS ET OUVRIR LES SECTIONNEURS A DISTANCE, PUIS SUIVRE LES PROCEDURES DE VERROUILLAGE ET DES ETIQUETTES AVANT TOUTE INTERVENTION. VERIFIER QUE TOUS LES CONDENSATEURS DES MOTEURS SONT DECHARGES. DANS LE CAS D'UNITES COMPORTANT DES ENTRAINEMENTS A VITESSE VARIABLE, SE REPORTER AUX INSTRUCTIONS DE L'ENTRAINEMENT POUR DECHARGER LES CONDENSATEURS.</p> <p>NE PAS RESPECTER CES MESURES DE PRECAUTION PEUT ENTRAINER DES BLESSURES GRAVES POUVANT ETRE MORTELLES.</p>	<p><b>⚠ ADVERTENCIA</b></p> <p><b>¡VOLTAJE PELIGROSO!</b></p> <p>DESCONECTE TODA LA ENERGIA ELECTRICA, INCLUSO LAS DESCONEXIONES REMOTAS Y SIGA LOS PROCEDIMIENTOS DE CIERRE Y ETIQUETADO ANTES DE PROCEDER AL SERVICIO. ASEGURESE DE QUE TODOS LOS CAPACITORES DEL MOTOR HAYAN DESCARGADO EL VOLTAJE ALMACENADO. PARA LAS UNIDADES CON EJE DE DIRECCION DE VELOCIDAD VARIABLE, CONSULTE LAS INSTRUCCIONES PARA LA DESCARGA DEL CONDENSADOR.</p> <p>EL NO REALIZAR LO ANTERIORMENTE INDICADO, PODRIA OCASIONAR LA MUERTE O SERIAS LESIONES PERSONALES.</p>
---	--	--

**CAUTION**

USE COPPER CONDUCTORS ONLY!

UNIT TERMINALS ARE NOT DESIGNED TO ACCEPT OTHER TYPES OF CONDUCTORS.

FAILURE TO DO SO MAY CAUSE DAMAGE TO THE EQUIPMENT.

**ATTENTION**

N'UTILISER QUE DES CONDUCTEURS EN CUIVRE!

LES BORNES DE L'UNITE NE SONT PAS CONCUES POUR RECEVOIR D'AUTRES TYPES DE CONDUCTEURS.

L'UTILISATION DE TOUT AUTRE CONDUCTEUR PEUT ENDOMMAGER L'EQUIPEMENT.

**PRECAUCION**

UTILICE UNICAMENTE CONDUCTORES DE COBRE!

LAS TERMINALES DE LA UNIDAD NO ESTAN DISENADAS PARA ACEPTAR OTROS TIPOS DE CONDUCTORES.

SI NO LO HACE, PUEDE OCASIONAR DANO AL EQUIPO.

**IMPORTANT!**

DO NOT ENERGIZE UNIT UNTIL CHECK-OUT AND START-UP PROCEDURE HAS BEEN COMPLETED.

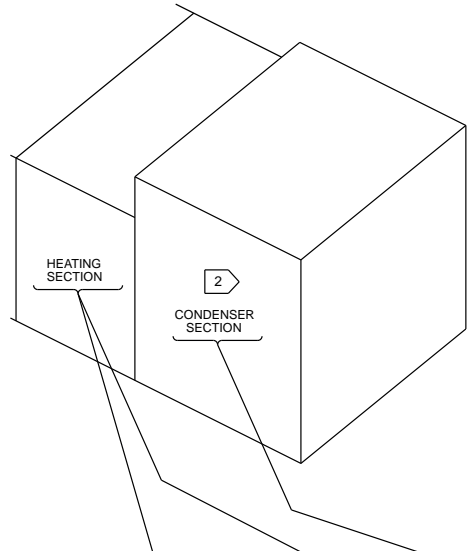

DEVICE PREFIX LOCATION CODE	
AREA	LOCATION
1	INSIDE UNIT CONTROL BOX
2	CONDENSER SECTION
3	AIR HANDLER SECTION
4	HEATING SECTION
5	EXTERNAL FIELD MOUNTED DEVICE

**Note:**  
All wiring and components shown dashed to be supplied and installed by the customer in accordance with local electrical codes.

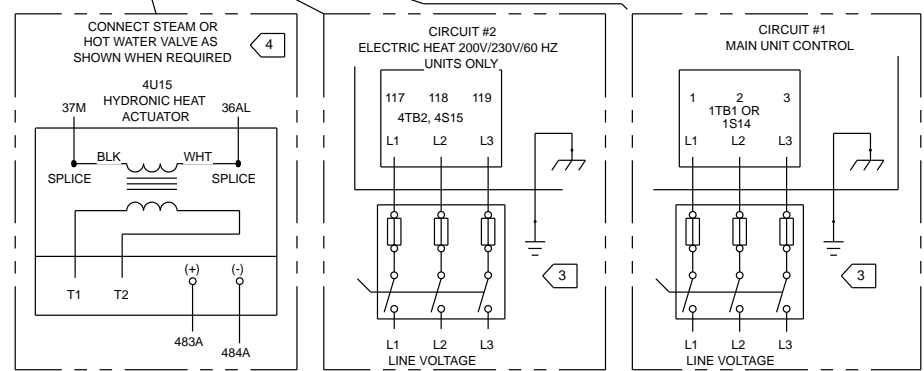

**Accessory - Commercial Rooftop Air Conditioning Units (Midrange)****Item: A1 - A10 Qty: 10 Tag(s): RTU-1N, RTU-1S, RTU-2N, RTU-2S, RTU-3N, RTU-3S, RTU-4N, RTU-4S, RTU-5N, RTU-5S**

## NOTES:

- 1 ALL WIRING AND COMPONENTS SHOWN DASHED TO BE SUPPLIED AND INSTALLED BY THE CUSTOMER IN ACCORDANCE WITH LOCAL ELECTRICAL CODES.
- 2 CUSTOMER CONNECTIONS - MAIN UNIT CONTROL (CIRCUIT #1) - ARE LOCATED IN THE CONDENSER SECTION FOR 20 THRU 75 TON UNITS.
- 3 SEE CUSTOMER CONNECTION WIRE RANGE TABLE FOR ACCEPTABLE WIRE SIZES FOR CONNECTION TO MAIN UNIT TERMINAL BLOCK (1TB1/4TB2) OR DISCONNECT SWITCH (1S14/4S15).
- 4 WIRES TO THE OPTIONAL STEAM AND/OR HOT WATER HEAT VALVE ARE SUPPLIED WITH THE UNIT. WIRE CONNECTIONS TO THE VALVE TO BE MADE BY THE CUSTOMER.
- 6 OPTIONAL 5U57 REMOTE ZONE TEMP SENSOR IS USED FOR UNOCCUPIED HEAT/COOL TEMP CONTROL SENSING.
- 7 WHEN 5U69 REMOTE ZONE TEMP SENSOR IS USED, REMOVE 5U58 INTERGRAL ZONE TEMP SENSOR ATTACHED TO TERMINALS S1 AND S2.
- 8 WIRES USE SHIELDED TWISTED PAIR WIRE.
- 9 USE SHIELDED TWISTED PAIR WIRE. WRAP SHIELDS WITH TAPE TO PREVENT CONTACT WITH GROUND.
- 10 REMOVE JUMPER (1TB4-15 & 1TB4-16) AND INSTALL HIGH DUCT TEMP T-STAT /OR FIELD SUPPLIED DEVICE.
- 11 REMOVE JUMPER (1TB4-17 & 1TB4-18) WHEN FIELD SUPPLIED EXTERNAL AUTO/STOP SWITCH (5S67) IS INSTALLED.
- 12 CHANGEOVER (5K87) AVAILABLE ONLY ON HYDRONIC HEAT UNITS OR MODULATING GAS HEAT UNITS.
- 13 ALARM OUTPUT SWITCHES ON ANY MANUAL RESET DIAGNOSTIC.
- 14 OPTIONAL HEAT MODULE AUX. TEMP (5RT16) IS USED FOR MORNING WARM-UP CONTROL ON UNITS WITH HEATING OPTION.
- 15 TERMINAL BLOCK 1TB17 AND ASSOCIATED WIRING REQUIRED WITH GBAS (1U51) OPTION. DEMAND LIMIT RELAY (5K89) TO BE PROVIDED BY CUSTOMER.
- 16 VENTILATION OVERRIDE MODE CONTACTS RATED 12MA @ 24VDC MINIMUM (5K90 - 5K91 - 5K92 - 5K93 - 5K94) TO BE PROVIDED BY CUSTOMER.
- 17 WIRE NODES 533 & 534 REQUIRED WITH BAS/NETWORK COMM MODULE (1U54) OPTION. USE SHIELDED TWISTED PAIR WIRE.
- 18 FIELD CONNECTIONS TO DRIVE VAV BOXES FULL OPEN DURING NIGHT SETBACK MODE.
- 19 15A FUSE REPLACEMENT IS REQUIRED FOR 50 THRU 60 TON - 0.50 KVA TRANSFORMER WITH 200V - 230V - 460V OR 575V UNIT VOLTAGE.  
20A FUSE REPLACEMENT IS REQUIRED FOR 50 THRU 60 TON - 0.50 KVA TRANSFORMER WITH 380V OR 415V UNIT VOLTAGE.
- 21 CONTACTS RATED 12 MA @ 24VDC MINIMUM.
- 22 CONNECT TO 24VAC CLASS 2 CIRCUITS ONLY.
- 23 REMOVE JUMPER WHEN OPTIONAL FIELD SUPPLIED OUTSIDE AIR SENSOR (3RT3) IS INSTALLED AND THE UNIT DOES NOT HAVE ECONOMIZER.
- 24 FIELD SUPPLIED AND INSTALLED OCCUPIED/UNOCCUPIED CONTACTS (5K86) FOR USE ON UNITS WITHOUT REMOTE PANEL WITH NIGHT SETBACK (5U58).
- 25 GBAS 0-5V OPTION CONNECTIONS.
- 26 GBAS 0-10V OPTION CONNECTIONS.
- 27 FOR GBAS INPUTS A11-A14, "GBAS 0-5V" REQUIRES 0-5V VDC AND "GBAS 0-10V" REQUIRES 0-10VDC.
- 28 "ACTIVE DIAGNOSTICS (BO5)" APPEARS WITH BOTH "GBAS 0-5V" AND "GBAS 0-10V".
- 29 SEE FUSE REPLACEMENT TABLE ON VFD PANEL FOR VFD POWER FUSES (F40, F41, F42).
- 30 SWITCH A53, LOCATED ON THE VFD, MUST BE SET TO "U" (OFF).

**Accessory - Commercial Rooftop Air Conditioning Units (Midrange)**

**Item: A1 - A10 Qty: 10 Tag(s): RTU-1N, RTU-1S, RTU-2N, RTU-2S, RTU-3N, RTU-3S, RTU-4N, RTU-4S, RTU-5N, RTU-5S**

FUSE REPLACEMENT TABLE												
CONDENSER FAN FUSE 1F1 THRU 1F6 CLASS RK5	UNIT VOLTAGE	200	230	380	415	460	575					
	TIME DELAY	25A	25A	15A	15A	15A	15A					
CONTROL POWER FUSE												
CONTROL (1T1) TRANSFORMER RATING		0.25 KVA	0.30 KVA	0.50 KVA	0.75 KVA	1.00 KVA	1.50 KVA					
1F7 CLASS CC - TYPE FNQ-R	20-30 TON	6.25A	6.25A	--	10A	--	--					
	40 TON	15A	20A	--	20A	--	--					
	50-60 TON	--	--	15A	--	20A	--					
	70-75 TON	--	--	--	--	15A	20A					
ELECTRIC HEAT FUSE	4F19 THRU 4F36, 4F46, 47, 48			CLASS K5			60A					
COMPRESSOR PROTECTION FUSE	1F44 & 1F45			TYPE MTH			6A					
TRANSFORMER CIRCUIT FUSE	1F72 THRU 1F74			TYPE FNQ-R			15A					
VFD PROTECTION FUSES (CLASS "T" FUSES) OPTIONAL SUPPLY VFD 1F57 - 1F62, OPTIONAL EXHAUST / RETURN VFD 1F63-1F65												
BELT DRIVE MOTOR 20-130 UNITS	UNIT VOLTAGE	FUSE RATING	3 HP	5 HP	7.5 HP	10 HP	15 HP	20 HP	25 HP	30 HP	40 HP	50 HP
	200V/60/3	600V	40A	60A	80A	100A	150A	200A	225A	300A	350A	N/A
	230V/60/3	600V	30A	45A	70A	90A	125A	175A	200A	250A	300A	N/A
	380V/50/3	600V	15A	30A	45A	50A	90A	100A	125A	150A	200A	N/A
	415V/50/3	600V	15A	30A	45A	50A	90A	100A	125A	150A	200A	N/A
	460V/60/3	600V	15A	25A	35A	45A	60A	90A	100A	125A	150A	200A
OPTIONAL DIRECT DRIVE MOTOR 20-59 UNITS	UNIT VOLTAGE	FUSE RATING	3 HP	5 HP	7.5 HP	10 HP	15 HP 1K-1.6K RPM	15 HP 1.7K-2.4K RPM	20 HP	25 HP	30 HP	
	200V/60/3	600V	40A	60A	80A	100A	150A	150A	200A	225A	300A	
	230V/60/3	600V	25A	45A	70A	90A	125A	125A	175A	200A	250A	
	460V/60/3	600V	15A	25A	35A	45A	70A	60A	90A	100A	125A	
	575V/60/3	600V	15A	15A	25A	35A	50A	50A	70A	80A	100A	
OPTIONAL DIRECTM DIVE MOTOR 60-89 TON	UNIT VOLTAGE	FUSE RATING	10HP	15 HP 1K-1.6K RPM	15 HP 1.7K-2.4K RPM	20HP	30 HP 1K-1.6K RPM	30 HP 1.7-2.4K RPM	40HP	50HP		
	200V/60/3	600V	125A	175A	150A	200A	300A	150A	350A	N/A		
	230V/60/3	600V	95A	150A	125A	175A	250A	250A	300A	N/A		
	460V/60/3	600V	45A	70A	60A	90A	125A	125A	150A	200A		
	575V/60/3	600V	40A	60A	50A	70A	125A	100A	125A	175A		
CUSTOMER CONNECTION WIRE RANGE												
NOTES: A. BLOCK SIZE & DISCONNECT SIZE ARE CALCULATED BY SELECTING THE SIZE GREATER THAN OR EQUAL TO 1.15 X (SUM OF UNIT LOADS). SEE UNIT LITERATURE FOR UNIT LOAD VALUES.	UNITS WITH MAIN POWER TERMINAL BLOCK (ALL VOLTAGES)						UNITS WITH MAIN POWER DISCONNECT SWITCH (ALL VOLTAGES)					
	BLOCK SIZE	WIRE QTY	CONNECTOR WIRE RANGE				DISCONNECT SIZE	WIRE QTY	CONNECTOR WIRE RANGE			
	335 AMP	(1)	#6 - 350 MCM				100 AMP	(1)	#14 - 1/0			
	760 AMP	(2)	#4 - 500 MCM				250 AMP	(1)	#4 - 350 kcmil			
	840 AMP	(2)	#2 - 600 MCM				400 AMP	(1) OR	#1 - 600 kcmil OR			
								(2)	#1 - 250 kcmil			
							600 AMP	(2)	250 - 500 MCM			
						1000 AMP	(3)	3/0 - 500 kcmil				
OPTIONAL CONVENIENCE OUTLET FUSE 1F55 AND 1F56 (TIME DELAY TYPE FNQ-R FUSE)		200V/60/3	230V/60/3	380V/50/3	415V/50/3	460V/60/3	575V/60/3					
		12A	10A	N/A	N/A	5A	4A					

**Accessory - Commercial Rooftop Air Conditioning Units (Midrange)**

**Item: A1 - A10 Qty: 10 Tag(s): RTU-1N, RTU-1S, RTU-2N, RTU-2S, RTU-3N, RTU-3S, RTU-4N, RTU-4S, RTU-5N, RTU-5S**

**WARNING**

**HAZARDOUS VOLTAGE!**  
DISCONNECT ALL ELECTRIC POWER INCLUDING REMOTE DISCONNECTS AND FOLLOW LOCK OUT AND TAG PROCEDURES BEFORE SERVICING. INSURE THAT ALL MOTOR CAPACITORS HAVE DISCHARGED STORED VOLTAGE. UNITS WITH VARIABLE SPEED DRIVE, REFER TO DRIVE INSTRUCTIONS FOR CAPACITOR DISCHARGE.  
  
FAILURE TO DO THE ABOVE BEFORE SERVICING COULD RESULT IN DEATH OR SERIOUS INJURY.

**AVERTISSEMENT**

**TENSION DANGEREUSE!**  
COUPER TOUTES LES TENSIONS ET OUVRIRE LES SECTIONNEURS A DISTANCE, PUIS SUIVRE LES PROCEDURES DE VERROUILLAGE ET DES ETIQUETTES AVANT TOUTE INTERVENTION. VERIFIER QUE TOUTS LES CONDENSATEURS DES MOTEURS SONT DECHARGES. DANS LE CAS D'UNITES COMPORTANT DES ENTRAINEMENTS A VITESSE VARIABLE, SE REPORTER AUX INSTRUCTIONS DE L'ENTRAINEMENT POUR DECHARGER LES CONDENSATEURS.  
  
NE PAS RESPECTER CES MESURES DE PRECAUTION PEUT ENTRAENER DES BLESSURES GRAVES POUVANT ETRE MORTELLES.

**ADVERTENCIA**

**¡VOLTAJE PELIGROSO!**  
DESCONECTE TODA LA ENERGIA ELECTRICA, INCLUSO LAS DESCONEXIONES REMOTAS Y SIGA LOS PROCEDIMIENTOS DE CIERRE Y ETIQUETADO ANTES DE PROCEDER AL SERVICIO. ASEGURESE DE QUE TODOS LOS CAPACITORES DEL MOTOR HAYAN DESCARGADO EL VOLTAJE ALMACENADO. PARA LAS UNIDADES CON EJE DE DIRECCION DE VELOCIDAD VARIABLE, CONSULTE LAS INSTRUCCIONES PARA LA DESCARGA DEL CONDENSADOR.  
  
EL NO REALIZAR LO ANTERIORMENTE INDICADO, PODRIA OCASIONAR LA MUERTE O SERIAS LESIONES PERSONALES.

**CAUTION**

USE COPPER CONDUCTORS ONLY!  
  
UNIT TERMINALS ARE NOT DESIGNED TO ACCEPT OTHER TYPES OF CONDUCTORS.  
  
FAILURE TO DO SO MAY CAUSE DAMAGE TO THE EQUIPMENT.

**ATTENTION**

N'UTILISER QUE DES CONDUCTEURS EN CUIVRE!  
  
LES BORNES DE L'UNITE NE SONT PAS CONCUES POUR RECEVOIR D'AUTRES TYPES DE CONDUCTEURS.  
  
L'UTILISATION DE TOUT AUTRE CONDUCTEUR PEUT ENDOMMAGER L'EQUIPEMENT.

**PRECAUCION**

UTILICE UNICAMENTE CONDUCTORES DE COBRE!  
  
LAS TERMINALES DE LA UNIDAD NO ESTAN DISENADAS PARA ACEPTAR OTROS TIPOS DE CONDUCTORES.  
  
SI NO LO HACE, PUEDE OCASIONAR DANO AL EQUIPO.

**IMPORTANT!**

DO NOT ENERGIZE UNIT UNTIL CHECK-OUT AND START-UP PROCEDURE HAS BEEN COMPLETED.

DEVICE PREFIX LOCATION CODE	
AREA	LOCATION
1	INSIDE UNIT CONTROL BOX
2	CONDENSER SECTION
3	AIR HANDLER SECTION
4	HEATING SECTION
5	EXTERNAL FIELD MOUNTED DEVICE

Note:  
All wiring and components shown dashed to be supplied and installed by the customer in accordance with local electrical codes.

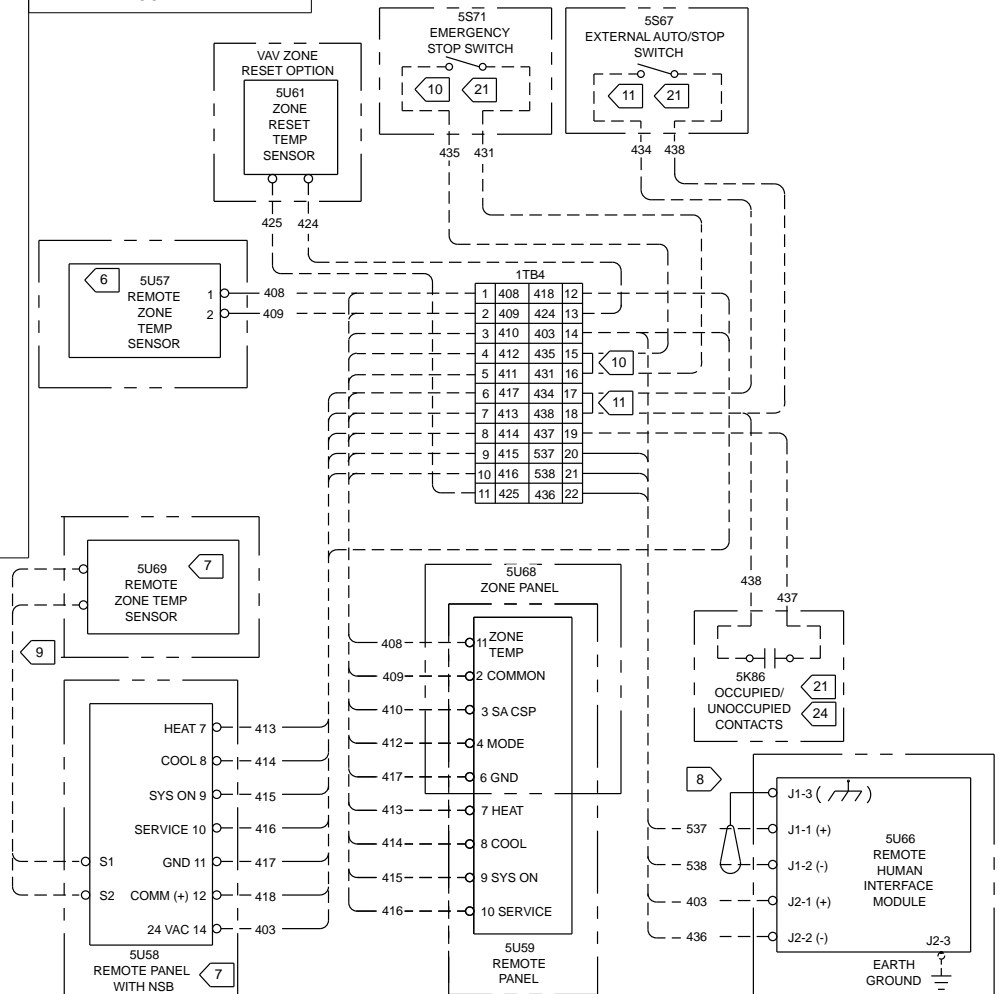

**Accessory - Commercial Rooftop Air Conditioning Units (Midrange)**

**Item: A1 - A10 Qty: 10 Tag(s): RTU-1N, RTU-1S, RTU-2N, RTU-2S, RTU-3N, RTU-3S, RTU-4N, RTU-4S, RTU-5N, RTU-5S**

**⚠ WARNING**

**HAZARDOUS VOLTAGE!**

DISCONNECT ALL ELECTRIC POWER INCLUDING REMOTE DISCONNECTS AND FOLLOW LOCK OUT AND TAG PROCEDURES BEFORE SERVICING. INSURE THAT ALL MOTOR CAPACITORS HAVE DISCHARGED STORED VOLTAGE. UNITS WITH VARIABLE SPEED DRIVE, REFER TO DRIVE INSTRUCTIONS FOR CAPACITOR DISCHARGE.

FAILURE TO DO THE ABOVE BEFORE SERVICING COULD RESULT IN DEATH OR SERIOUS INJURY.

**⚠ AVERTISSEMENT**

**TENSION DANGEREUSE!**

COUPER TOUTES LES TENSIONS ET OUVRIRE LES SECTIONNEURS A DISTANCE, PUIS SUIVRE LES PROCEDURES DE VERROUILLAGE ET DES ETIQUETTES AVANT TOUTE INTERVENTION. VERIFIER QUE TOUS LES CONDENSATEURS DES MOTEURS SONT DECHARGES. DANS LE CAS D'UNITES COMPORTANT DES ENTRAINEMENTS A VITESSE VARIABLE, SE REPORTER AUX INSTRUCTIONS DE L'ENTRAINEMENT POUR DECHARGER LES CONDENSATEURS.

NE PAS RESPECTER CES MESURES DE PRECAUTION PEUT ENTRAÎNER DES BLESSURES GRAVES POUVANT ETRE MORTELLES.

**⚠ ADVERTENCIA**

**¡VOLTAJE PELIGROSO!**

DESCONECTE TODA LA ENERGIA ELECTRICA, INCLUSO LAS DESCONEXIONES REMOTAS Y SIGA LOS PROCEDIMIENTOS DE CIERRE Y ETIQUETADO ANTES DE PROCEDER AL SERVICIO. ASEGURESE DE QUE TODOS LOS CAPACITORES DEL MOTOR HAYAN DESCARGADO EL VOLTAJE ALMACENADO. PARA LAS UNIDADES CON EJE DE DIRECCION DE VELOCIDAD VARIABLE, CONSULTE LAS INSTRUCCIONES PARA LA DESCARGA DEL CONDENSADOR.

EL NO REALIZAR LO ANTERIORMENTE INDICADO, PODRIA OCASIONAR LA MUERTE O SERIAS LESIONES PERSONALES.

**CAUTION**

USE COPPER CONDUCTORS ONLY!

UNIT TERMINALS ARE NOT DESIGNED TO ACCEPT OTHER TYPES OF CONDUCTORS.

FAILURE TO DO SO MAY CAUSE DAMAGE TO THE EQUIPMENT.

**ATTENTION**

N'UTILISER QUE DES CONDUCTEURS EN CUIVRE!

LES BORNES DE L'UNITE NE SONT PAS CONÇUES POUR RECEVOIR D'AUTRES TYPES DE CONDUCTEURS.

L'UTILISATION DE TOUT AUTRE CONDUCTEUR PEUT ENDOMMAGER L'EQUIPEMENT.

**PRECAUCION**

UTILICE UNICAMENTE CONDUCTORES DE COBRE!

LAS TERMINALES DE LA UNIDAD NO ESTAN DISEÑADAS PARA ACEPTAR OTROS TIPOS DE CONDUCTORES.

SI NO LO HACE, PUEDE OCASIONAR DANO AL EQUIPO.

**IMPORTANT!**

DO NOT ENERGIZE UNIT UNTIL CHECK-OUT AND START-UP PROCEDURE HAS BEEN COMPLETED.

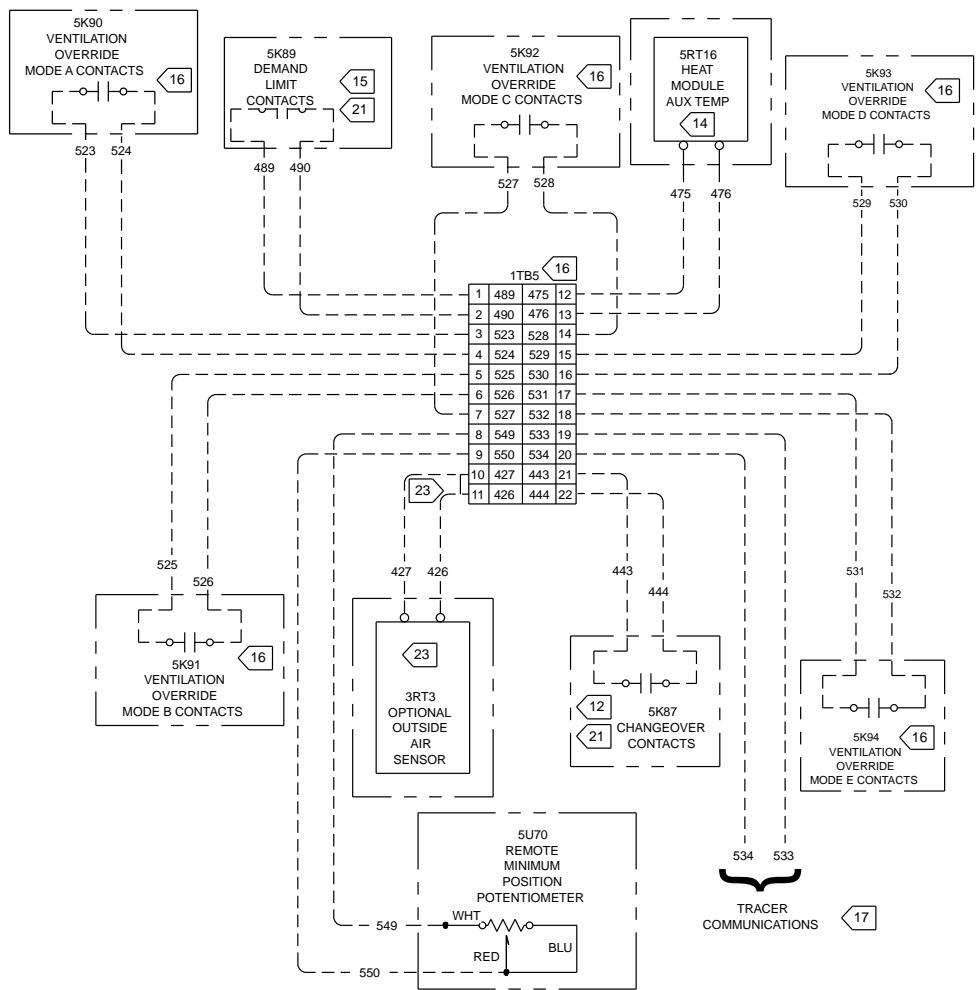

DEVICE PREFIX LOCATION CODE	
AREA	LOCATION
1	INSIDE UNIT CONTROL BOX
2	CONDENSER SECTION
3	AIR HANDLER SECTION
4	HEATING SECTION
5	EXTERNAL FIELD MOUNTED DEVICE

**Note:**  
All wiring and components shown dashed to be supplied and installed by the customer in accordance with local electrical codes.

**Accessory - Commercial Rooftop Air Conditioning Units (Midrange)**

**Item: A1 - A10 Qty: 10 Tag(s): RTU-1N, RTU-1S, RTU-2N, RTU-2S, RTU-3N, RTU-3S, RTU-4N, RTU-4S, RTU-5N, RTU-5S**



**WARNING**

**HAZARDOUS VOLTAGE!**

DISCONNECT ALL ELECTRIC POWER INCLUDING REMOTE DISCONNECTS AND FOLLOW LOCK OUT AND TAG PROCEDURES BEFORE SERVICING. INSURE THAT ALL MOTOR CAPACITORS HAVE DISCHARGED STORED VOLTAGE. UNITS WITH VARIABLE SPEED DRIVE, REFER TO DRIVE INSTRUCTIONS FOR CAPACITOR DISCHARGE.

FAILURE TO DO THE ABOVE BEFORE SERVICING COULD RESULT IN DEATH OR SERIOUS INJURY.



**AVERTISSEMENT**

**TENSION DANGEREUSE!**

COUPER TOUTES LES TENSIONS ET OUVRIER LES SECTIONNEURS A DISTANCE, PUIS SUIVRE LES PROCEDURES DE VERROUILLAGE ET DES ETIQUETTES AVANT TOUTE INTERVENTION. VERIFIER QUE TOUS LES CONDENSATEURS DES MOTEURS SONT DECHARGES. DANS LE CAS D'UNITES COMPORTANT DES ENTRAINEMENTS A VITESSE VARIABLE, SE REPORTER AUX INSTRUCTIONS DE L'ENTRAINEMENT POUR DECHARGER LES CONDENSATEURS.

NE PAS RESPECTER CES MESURES DE PRECAUTION PEUT ENTRAENER DES BLESSURES GRAVES POUVANT ETRE MORTELLES.



**ADVERTENCIA**

**¡VOLTAJE PELIGROSO!**

DESCONECTE TODA LA ENERGIA ELECTRICA, INCLUSO LAS DESCONEXIONES REMOTAS Y SIGA LOS PROCEDIMIENTOS DE CIERRE Y ETIQUETADO ANTES DE PROCEDER AL SERVICIO. ASEGURESE DE QUE TODOS LOS CAPACITORES DEL MOTOR HAYAN DESCARGADO EL VOLTAJE ALMACENADO. PARA LAS UNIDADES CON EJE DE DIRECCION DE VELOCIDAD VARIABLE, CONSULTE LAS INSTRUCCIONES PARA LA DESCARGA DEL CONDENSADOR.

EL NO REALIZAR LO ANTERIORMENTE INDICADO, PODRIA OCASIONAR LA MUERTE O SERIAS LESIONES PERSONALES.

**CAUTION**

USE COPPER CONDUCTORS ONLY!

UNIT TERMINALS ARE NOT DESIGNED TO ACCEPT OTHER TYPES OF CONDUCTORS.

FAILURE TO DO SO MAY CAUSE DAMAGE TO THE EQUIPMENT.

**ATTENTION**

N'UTILISER QUE DES CONDUCTEURS EN CUIVRE!

LES BORNES DE L'UNITE NE SONT PAS CONCUES POUR RECEVOIR D'AUTRES TYPES DE CONDUCTEURS.

L'UTILISATION DE TOUT AUTRE CONDUCTEUR PEUT ENDOMMAGER L'EQUIPEMENT.

**PRECAUCION**

UTILICE UNICAMENTE CONDUCTORES DE COBRE!

LAS TERMINALES DE LA UNIDAD NO ESTAN DISENADAS PARA ACEPTAR OTROS TIPOS DE CONDUCTORES.

SI NO LO HACE, PUEDE OCASIONAR DANO AL EQUIPO.

**IMPORTANT!**

DO NOT ENERGIZE UNIT UNTIL CHECK-OUT AND START-UP PROCEDURE HAS BEEN COMPLETED.

DEVICE PREFIX LOCATION CODE	
AREA	LOCATION
1	INSIDE UNIT CONTROL BOX
2	CONDENSER SECTION
3	AIR HANDLER SECTION
4	HEATING SECTION
5	EXTERNAL FIELD MOUNTED DEVICE

**Note:**  
All wiring and components shown dashed to be supplied and installed by the customer in accordance with local electrical codes.

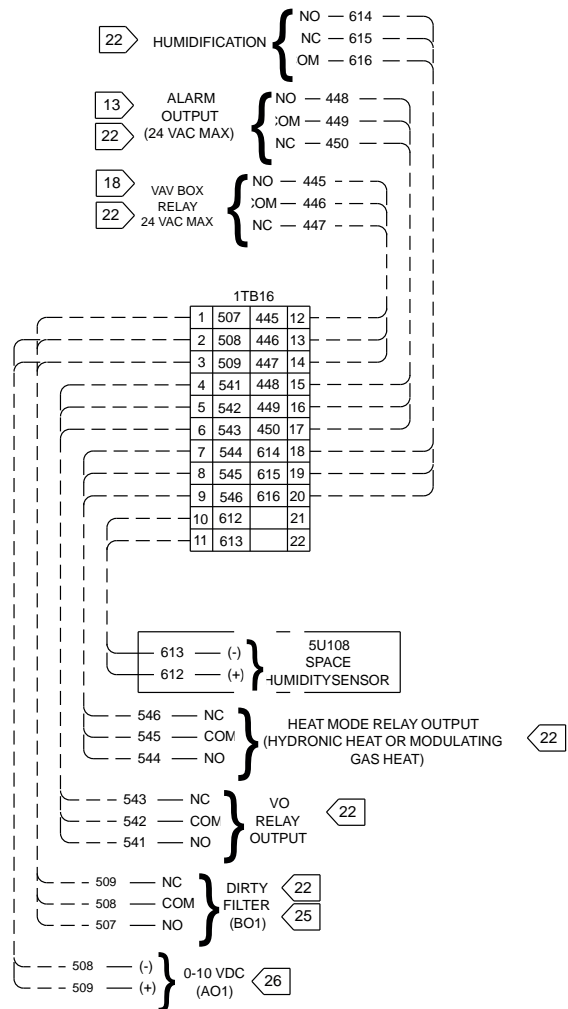

**Accessory - Commercial Rooftop Air Conditioning Units (Midrange)**

Item: A1 - A10 Qty: 10 Tag(s): RTU-1N, RTU-1S, RTU-2N, RTU-2S, RTU-3N, RTU-3S, RTU-4N, RTU-4S, RTU-5N, RTU-5S

DANFOSS VARIABLE FREQUENCY DRIVE PROGRAMMING PARAMETERS			
MENU	PARAMETER	DESCRIPTION	SETTING
LOAD/MOTOR	1-21	MOTOR POWER	SET ONLY FOR APPLICATIONS USING 3HP HIGH EFFICIENCY MOTORS
	1-22	MOTOR VOLTAGE	SET ONLY FOR 200/230V 60HZ 380/415V 50HZ APPLICATIONS
	1-24	MOTOR CURRENT	SET BASED ON MOTOR NAMEPLATE
	1-25	MOTOR NOMINAL SPEED	1800 RPM
	1-73	FLYING START	ENABLED
BRAKES	2-01	DC BRAKE CURRENT	0%
REFERENCE/ RAMPS	3-15	REFERENCE 1 SOURCE	ANALOG INPUT 53 <span style="border: 1px solid black; border-radius: 50%; padding: 2px;">30</span>
	3-41	RAMP 1 RAMP UP TIME	30 SECONDS
	3-42	RAMP 1 RAMP DOWN TIME	30 SECONDS
LIMITS/ WARNINGS	4-12	MOTOR SPEED LOW LIMIT	22HZ
	4-18	CURRENT LIMIT	100% RATED CURRENT
DIGITAL IN/OUT	5-40[0]	FUNCTION RELAY 1	NO ALARM
	5-40[1]	FUNCTION RELAY 2	RUNNING
SPECIAL FUNCTIONS	14-01	SWITCHING FREQUENCY	4.5KHZ
	14-12	FUNCTION AT MAINS IMBALANCE	DERATE
	14-20	RESET MODE	AUTOMATIC RESET X 3
	14-60	FUNCTION AT OVER TEMPERATURE	DERATE

1" Deflection

RTU-1N, 2N, 2S, 3N, 3S, 4N, 4S, 5N, 5S

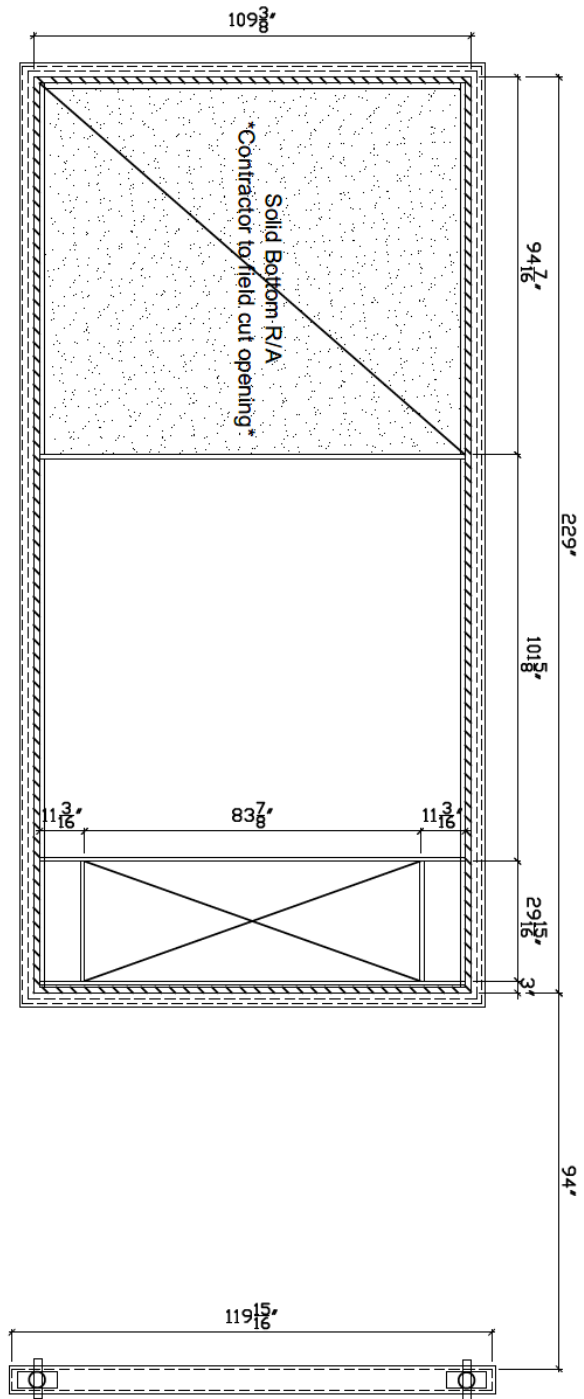
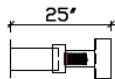
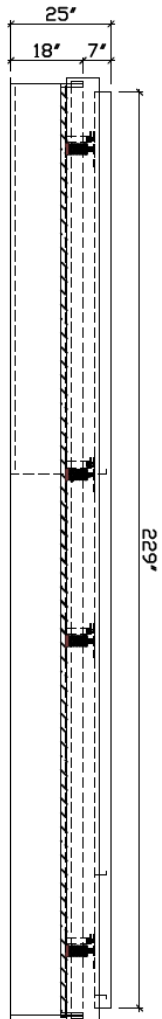

Units:	SAHLF60-70
DWG#:	
Qty:	9
Job#:	
Ship Date:	
Drawn by:	TR

