

Project number: 40705

Project name: IBP XVIII

Note: This submittal is based on equipment and options listed on the attachment(s) and represents our interpretation of your requirements. It is the representative's responsibility to review this submittal and verify that it meets the job specifications.

Project Information

Project name: IBP XVIII

Location: _____

Architect: _____

MEP firm: Venture Mechanical

Mechanical contractor: Venture Mechanical

Date: 10/24/2021

Sales Representative

Submitted by: Bartos Industries

Approvals

Owner's representative: _____

Engineer of record: _____

Mechanical Contractor: _____

PROJECT SCHEDULE																																			
General Unit Data									Static Pressure				Max NC Levels		Fan Powered								Heating Coil Data												
Tag	Qty	Model	Inlet Size	Casing	Handing	Outlet Dim WxH	Max Prim. Airflow (CFM)	Min Prim. Airflow (CFM)	Inlet (in. H2O)	Down stream (in. H2O)	Min Drop (in. H2O)	Unit Drop (in. H2O)	Rad NC	Dis NC	Max Fan Airflow (CFM)	Min Fan Airflow (CFM)	Design Fan Airflow (CFM)	HP	Static Pressure (in. H2O)	Voltage	FLA	MCA	MOCP	Heating Type	Heating Airflow (CFM)	Prim. Heating Ariflow (CFM)	Entering Air Temp (°F)	Leaving Air Temp (°F)	Box LAT (°F)	Electric Heat Capacity (kW)	Volt / Phase	Steps	Notes		
VAV-Cooling Only	8	TH	08	C08	RR	12x10	650	100	1	0.25	0.077	0.077	20	26			0							0	None	0									
VRH-1N-1	1	TH	08	C08	RR	12x10	700	210	1	0.25	0.09	0.09	20	21			0							15	EH	210	210	55	77.57	77.57	1.5	277-1	1 step		
VRH-2S-1	1	TH	06	C06	RR	12x8	300	100	1	0.25	0.071	0.071	18	< 15			0							15	EH	100	100	55	86.6	86.6	1	277-1	1 step		
VRH-5N-1	1	TH	08	C08	RR	12x10	650	100	1	0.25	0.077	0.077	20	24			0							15	EH	200	200	55	78.7	78.7	1.5	277-1	1 step		
VRH-5S-1	1	TH	08	C08	RR	12x10	650	100	1	0.25	0.077	0.077	20	24			0							15	EH	200	200	55	78.7	78.7	1.5	277-1	1 step		
CV-1N-1	1	FCI	08	C2	LL	16x15	420	100	1	0.25	0.034	0.034	26	18	740	175	420	1/8	0.25	277/1	1.1	7.39	15	EH	420	100	55	95	95	4	480-3	1 step			
CV-1S-1	1	FCI	06	C2	LL	16x15	300	100	1	0.25	0.017	0.017	24	18	740	175	300	1/8	0.25	277/1	1.1	5.89	15	EH	300	100	55	95.27	95.27	3	480-3	1 step			
CV-2N-1	1	FCI	08	C2	LL	16x15	420	100	1	0.25	0.034	0.034	26	18	740	175	420	1/8	0.25	277/1	1.1	7.39	15	EH	420	100	55	95	95	4	480-3	1 step			
CV-2S-1	1	FCI	06	C2	LL	16x15	300	100	1	0.25	0.017	0.017	24	18	740	175	300	1/8	0.25	277/1	1.1	5.89	15	EH	300	100	55	95.27	95.27	3	480-3	1 step			
CV-3N-1	1	FCI	08	C2	LL	16x15	420	100	1	0.25	0.034	0.034	26	18	740	175	420	1/8	0.25	277/1	1.1	7.39	15	EH	420	100	55	95	95	4	480-3	1 step			
CV-3S-1	1	FCI	06	C2	LL	16x15	300	100	1	0.25	0.017	0.017	24	18	740	175	300	1/8	0.25	277/1	1.1	5.89	15	EH	300	100	55	95.27	95.27	3	480-3	1 step			
CV-4N-1	1	FCI	08	C2	LL	16x15	420	100	1	0.25	0.034	0.034	26	18	740	175	420	1/8	0.25	277/1	1.1	7.39	15	EH	420	100	55	95	95	4	480-3	1 step			
CV-4S-1	1	FCI	06	C2	LL	16x15	300	100	1	0.25	0.017	0.017	24	18	740	175	300	1/8	0.25	277/1	1.1	5.89	15	EH	300	100	55	95.27	95.27	3	480-3	1 step			
CV-5N-1	1	FCI	08	C2	LL	16x15	420	100	1	0.25	0.034	0.034	26	18	740	175	420	1/8	0.25	277/1	1.1	7.39	15	EH	420	100	55	95	95	4	480-3	1 step			
CV-5S-1	1	FCI	06	C2	LL	16x15	300	100	1	0.25	0.017	0.017	24	18	740	175	300	1/8	0.25	277/1	1.1	5.89	15	EH	300	100	55	95.27	95.27	3	480-3	1 step			
FPB-1S-1	1	FVI	08	C2	LL	16x15	500	50	1	0.25	0.1	0.1	25	< 15	687	360	350	1/6	0.25	277/1	1.1	5.13	15	EH	400	50	55	86.13	86.13	2.5	480-3	1 step			
FPB-2N-1	1	FVI	14	C5	LL	20x17.5	2400	240	1	0.25	0.112	0.112	39	31	1742	954	1610	1/3	0.25	277/1	3.6	31.56	35	EH	1850	240	55	97.06	97.06	18	480-3	2 steps			
FPB-2N-2	1	FVI	10	C2	LL	16x15	1000	100	1	0.25	0.103	0.103	29	16	687	360	500	1/6	0.25	277/1	1.1	10.4	15	EH	600	100	55	97.43	97.43	6	480-3	1 step			
FPB-2S-1	1	FVI	12	C5	LL	20x17.5	2000	200	1	0.25	0.109	0.109	35	21	1742	954	1340	1/3	0.25	277/1	3.6	27.05	30	EH	1540	200	55	97.09	97.09	15	480-3	2 steps			
FPB-2S-2	1	FVI	08	C2	LL	16x15	600	60	1	0.25	0.105	0.105	26	< 15	687	360	400	1/6	0.25	277/1	1.1	8.14	15	EH	460	60	55	97.22	97.22	4.5	480-3	1 step			
VAV-1S-2	1	TH	10	C10	RR	14x12.5	1150	100	1	0.25	0.042	0.042	22	24			0							0	None	0									

Notes

1. All sound power levels references 1 x 10⁻¹² watts.
2. Room NC levels calculated at the Operating Ps Drop.
3. Sound data obtained from tests conducted in accordance with AHRI Standards 880-2011
4. Legend:
 - i. **Apd:** air pressure drop across hot water coil
 - ii. **Min Ps:** minimim static pressure loss through ATU
 - iii. **Unit Ps:** Min Ps + Apd except for all FC boxes and for FV boxes with inlet coil
 - iv. **Op Ps:** Operating Ps Drop
 - v. **Wpd:** head loss or water pressure drop
 - vi. **ESP:** ATU fan external static pressure = Apd + Outlet / Downstream Ps
 - vii. **MRE:** Motor Rates Amps
 - viii. **Heat Flow:** Airflow through hot water coil or electric heater
 - ix. **DAT:** Discharge Air Temperature

PROJECT TAGGING SCHEDULE												
Primary Tag	Item Tag	Qty	Detail	Code String	Max Airflow	Min Airflow	Fan Airflow	Hot Max Airflow	Hot Min Airflow	Heating Airflow	Fan Voltage	
VAV-Cooling Only	VAV-1N-1	1	TH-508	TH 5 08 STU NA NH Z07 Z82 Z55 Z91 Z23 USR 105A Z01 31	650	100	0	0	0	0		
VAV-Cooling Only	VAV-1S-1	1	TH-508	TH 5 08 STU NA NH Z07 Z82 Z55 Z91 Z23 USR 105A Z01 31	650	100	0	0	0	0		
VAV-Cooling Only	VAV-2N-1	1	TH-508	TH 5 08 STU NA NH Z07 Z82 Z55 Z91 Z23 USR 105A Z01 31	650	100	0	0	0	0		
VAV-Cooling Only	VAV-2S-1	1	TH-508	TH 5 08 STU NA NH Z07 Z82 Z55 Z91 Z23 USR 105A Z01 31	650	100	0	0	0	0		
VAV-Cooling Only	VAV-3N-1	1	TH-508	TH 5 08 STU NA NH Z07 Z82 Z55 Z91 Z23 USR 105A Z01 31	650	100	0	0	0	0		
VAV-Cooling Only	VAV-3S-1	1	TH-508	TH 5 08 STU NA NH Z07 Z82 Z55 Z91 Z23 USR 105A Z01 31	650	100	0	0	0	0		
VAV-Cooling Only	VAV-4N-1	1	TH-508	TH 5 08 STU NA NH Z07 Z82 Z55 Z91 Z23 USR 105A Z01 31	650	100	0	0	0	0		
VAV-Cooling Only	VAV-4S-1	1	TH-508	TH 5 08 STU NA NH Z07 Z82 Z55 Z91 Z23 USR 105A Z01 31	650	100	0	0	0	0		
VRH-1N-1		1	TH-508 EH	TH 5 08 1.50 STU SA EH C HS1 ZB1 C3 D1 ZA1D ZP3 Z07 Z82 Z55 Z91 Z23 USR 105E Z01	700	210	0	0	0	210		
VRH-2S-1		1	TH-506 EH	TH 5 06 1.00 STU SA EH C HS1 ZB1 C3 D1 ZA1D ZP3 Z07 Z82 Z55 Z91 Z23 USR 105E Z01	300	100	0	0	0	100		
VRH-5N-1		1	TH-508 EH	TH 5 08 1.50 STU SA EH C HS1 ZB1 C3 D1 ZA1D ZP3 Z07 Z82 Z55 Z91 Z23 USR 105E Z01	650	100	0	0	0	200		
VRH-5S-1		1	TH-508 EH	TH 5 08 1.50 STU SA EH C HS1 ZB1 C3 D1 ZA1D ZP3 Z07 Z82 Z55 Z91 Z23 USR 105E Z01	650	100	0	0	0	200		
CV-1N-1		1	FCI-C2608C EH	FCI C2 6 08 4.00 C EH N HS1 ZB1 C3 D1 ZA1D ZP3 Z22 Z10 32 NIA Z02 Z49 Z88 Z23 82 USR 905E	420	100	420	0	0	420	277/1	
CV-1S-1		1	FCI-C2606C EH	FCI C2 6 06 3.00 C EH N HS1 ZB1 C3 D1 ZA1D ZP3 Z22 Z10 32 NIA Z02 Z49 Z88 Z23 82 USR 905E	300	100	300	0	0	300	277/1	
CV-2N-1		1	FCI-C2608C EH	FCI C2 6 08 4.00 C EH N HS1 ZB1 C3 D1 ZA1D ZP3 Z22 Z10 32 NIA Z02 Z49 Z88 Z23 82 USR 905E	420	100	420	0	0	420	277/1	
CV-2S-1		1	FCI-C2606C EH	FCI C2 6 06 3.00 C EH N HS1 ZB1 C3 D1 ZA1D ZP3 Z22 Z10 32 NIA Z02 Z49 Z88 Z23 82 USR 905E	300	100	300	0	0	300	277/1	
CV-3N-1		1	FCI-C2608C EH	FCI C2 6 08 4.00 C EH N HS1 ZB1 C3 D1 ZA1D ZP3 Z22 Z10 32 NIA Z02 Z49 Z88 Z23 82 USR 905E	420	100	420	0	0	420	277/1	
CV-3S-1		1	FCI-C2606C EH	FCI C2 6 06 3.00 C EH N HS1 ZB1 C3 D1 ZA1D ZP3 Z22 Z10 32 NIA Z02 Z49 Z88 Z23 82 USR 905E	300	100	300	0	0	300	277/1	
CV-4N-1		1	FCI-C2608C EH	FCI C2 6 08 4.00 C EH N HS1 ZB1 C3 D1 ZA1D ZP3 Z22 Z10 32 NIA Z02 Z49 Z88 Z23 82 USR 905E	420	100	420	0	0	420	277/1	
CV-4S-1		1	FCI-C2606C EH	FCI C2 6 06 3.00 C EH N HS1 ZB1 C3 D1 ZA1D ZP3 Z22 Z10 32 NIA Z02 Z49 Z88 Z23 82 USR 905E	300	100	300	0	0	300	277/1	
CV-5N-1		1	FCI-C2608C EH	FCI C2 6 08 4.00 C EH N HS1 ZB1 C3 D1 ZA1D ZP3 Z22 Z10 32 NIA Z02 Z49 Z88 Z23 82 USR 905E	420	100	420	0	0	420	277/1	
CV-5S-1		1	FCI-C2606C EH	FCI C2 6 06 3.00 C EH N HS1 ZB1 C3 D1 ZA1D ZP3 Z22 Z10 32 NIA Z02 Z49 Z88 Z23 82 USR 905E	300	100	300	0	0	300	277/1	
FPB-1S-1		1	FVI-C2508C EH	FVI C2 5 08 2.50 C EH N HS1 ZB1 C3 D1 ZA1D ZP3 Z22 Z10 32 NIA Z02 Z49 Z88 Z23 82 USR 805E	500	50	350	0	0	400	277/1	
FPB-2N-1		1	FVI-C5514C EH	FVI C5 5 14 18.00 C EH N HS2 ZB1 C3 D1 ZA1D ZP3 Z22 Z10 32 NIA Z02 Z49 Z88 Z23 82 USR 805E	2400	240	1610	0	0	1850	277/1	
FPB-2N-2		1	FVI-C2510C EH	FVI C2 5 10 6.00 C EH N HS1 ZB1 C3 D1 ZA1D ZP3 Z22 Z10 32 NIA Z02 Z49 Z88 Z23 82 USR 805E	1000	100	500	0	0	600	277/1	
FPB-2S-1		1	FVI-C5512C EH	FVI C5 5 12 15.00 C EH N HS2 ZB1 C3 D1 ZA1D ZP3 Z22 Z10 32 NIA Z02 Z49 Z88 Z23 82 USR 805E	2000	200	1340	0	0	1540	277/1	
FPB-2S-2		1	FVI-C2508C EH	FVI C2 5 08 4.50 C EH N HS1 ZB1 C3 D1 ZA1D ZP3 Z22 Z10 32 NIA Z02 Z49 Z88 Z23 82 USR 805E	600	60	400	0	0	460	277/1	
VAV-1S-2		1	TH-510	TH 5 10 STU NA NH Z07 Z82 Z55 Z91 Z23 USR 105A Z01 31	1150	100	0	0	0	0		

Project Summary

Qty	Model	Inlet Size	Casing Tag(s)	Model Description
8	TH	08	C08 VAV-Cooling Only	High Performance Single Duct Air Terminal Unit
1	TH	10	C10 VAV-1S-2	High Performance Single Duct Air Terminal Unit
1	TH	06	C06 VRH-2S-1	High Performance Single Duct Air Terminal Unit
3	TH	08	C08 VRH-1N-1, VRH-5N-1, VRH-5S-1	High Performance Single Duct Air Terminal Unit
5	FCI	06	C2 CV-1S-1, CV-2S-1, CV-3S-1, CV-4S-1, CV-5S-1	Series Fan Powered Air Terminal Unit
5	FCI	08	C2 CV-1N-1, CV-2N-1, CV-3N-1, CV-4N-1, CV-5N-1	Series Fan Powered Air Terminal Unit
1	FVI	08	C2 FPB-1S-1	Parallel Fan Powered Air Terminal Unit
1	FVI	08	C2 FPB-2S-2	Parallel Fan Powered Air Terminal Unit
1	FVI	10	C2 FPB-2N-2	Parallel Fan Powered Air Terminal Unit
1	FVI	12	C5 FPB-2S-1	Parallel Fan Powered Air Terminal Unit
1	FVI	14	C5 FPB-2N-1	Parallel Fan Powered Air Terminal Unit

Product Data: High Performance Single Duct Air Terminal Unit

Qty	Description	Model Number
8	High Performance Single Duct Air Terminal Unit	TH 5 08 STU NA NH Z07 Z82 Z55 Z91 Z23 USR 105A Z01 31

Tag(s): VAV-Cooling Only

Selected Options

- 08 Inlet Size : Inlet Size 08 (Min: 100 /Max: 990 CFM)
- STU Eco Low Leakage Series : Standard Terminal Unit
- NA Sound Attenuator : No Attenuator
- NH Heating Type : No Heating Option
- Z07 Casing Material : 22 Ga Construction
- Z82 Outlet : Slip and Drive Connection
- Z55 Liner : 1/2" Fiberglass 1 1/2 lbs.
- Z91 Handing : Handing- Control And Reheat(electric or water) Connections On Right
- Z23 Airflow Sensor : Multi Quadrant Averaging Flow Sensor
- USR Control Type (Select Control Sequence Second) : Controls by Other Factory Mounted
- 105A Control Sequence (Select Control Type First) : 105A - Factory Mounted Controls- 120/24 V trans
- Z01 Control Enclosure : Enclosure & Mounting Plate, Std Control Panel Enclosure and Std. Mntg Plate
- 31 Toggle Switch : Toggle Disconnect Switch

Product Data: High Performance Single Duct Air Terminal Unit

Qty	Description	Model Number
1	High Performance Single Duct Air Terminal Unit	TH 5 10 STU NA NH Z07 Z82 Z55 Z91 Z23 USR 105A Z01 31

Tag(s): VAV-1S-2

Selected Options

- 10 Inlet Size : Inlet Size 10 (Min: 165 /Max: 1640 CFM)
- STU Eco Low Leakage Series : Standard Terminal Unit
- NA Sound Attenuator : No Attenuator
- NH Heating Type : No Heating Option
- Z07 Casing Material : 22 Ga Construction
- Z82 Outlet : Slip and Drive Connection
- Z55 Liner : 1/2" Fiberglass 1 1/2 lbs.
- Z91 Handing : Handing- Control And Reheat(electric or water) Connections On Right
- Z23 Airflow Sensor : Multi Quadrant Averaging Flow Sensor
- USR Control Type (Select Control Sequence Second) : Controls by Other Factory Mounted
- 105A Control Sequence (Select Control Type First) : 105A - Factory Mounted Controls- 120/24 V trans
- Z01 Control Enclosure : Enclosure & Mounting Plate, Std Control Panel Enclosure and Std. Mntg Plate
- 31 Toggle Switch : Toggle Disconnect Switch

METALAIRE™ Model TH-508

Project: IBP XVIII
 Tag: VAV-Cooling Only
 Altitude: 0 Feet

VAV-1N-1, VAV-1S-1, VAV-2N-1, VAV-2S-1, VAV-3N-1, VAV-3S-1, VAV-4N-1, VAV-4S-1

Qty	Mode	Size		CFM		Static Pressure				Max NC Levels	
		Unit	Outlet	Max	Min	Inlet	Downstream	Min Drop	Unit Drop	Rad	Dis
8	TH	08	12x10	990	100	1.00	0.250	0.077	0.077	20	26
						0					



High Performance Single Duct Air Terminal Unit

Design Air Flow

Max Primary:	650 CFM
Min Primary:	100 CFM

Accessories:

Heating Coil:	None
Inlet:	No Attenuator
Outlet:	No Attenuator

Radiated Sound Power Level (db)

Discharge Sound Power Level (db)

Band	Radiated Sound Power Level (db)							NC	Band	Discharge Sound Power Level (db)							NC
	2	3	4	5	6	7	2			3	4	5	6	7			
Primary	58	49	41	36	29	24		Primary	72	66	57	54	47	42			
Total Attenuation	18	19	20	26	31	36		Total Attenuation	27	29	40	51	53	39			
Room Sound Level	40	30	21	10	0	0	20	Room Sound Level	45	37	17	3	0	3	26		

METALAIRE™ Model TH-510

Project: IBP XVIII
 Tag: VAV-1S-2
 Altitude: 0 Feet

Qty	Mode	Size		CFM		Static Pressure				Max NC Levels	
		Unit	Outlet	Max	Min	Inlet	Downstream	Min Drop	Unit Drop	Rad	Dis
1	TH	10	14x12 .5	1640	165	1.00 0	0.250	0.042	0.042	22	24



High Performance Single Duct Air Terminal Unit

Design Air Flow

Max Primary:	1150 CFM
Min Primary:	100 CFM

Accessories:

Heating Coil:	None
Inlet:	No Attenuator
Outlet:	No Attenuator

Radiated Sound Power Level (db)

Discharge Sound Power Level (db)

Band	Radiated Sound Power Level (db)							NC	Band	Discharge Sound Power Level (db)							NC
	2	3	4	5	6	7	2			3	4	5	6	7			
Primary	54	54	47	40	33	27		70	66	60	56	49	46				
Total Attenuation	18	19	20	26	31	36		29	30	41	51	52	39				
Room Sound Level	36	35	27	14	2	0	22	41	36	19	5	0	7	24			

TH500-001 - TH

Qty: 9 Tags: VAV-1S-2, VAV-Cooling Only

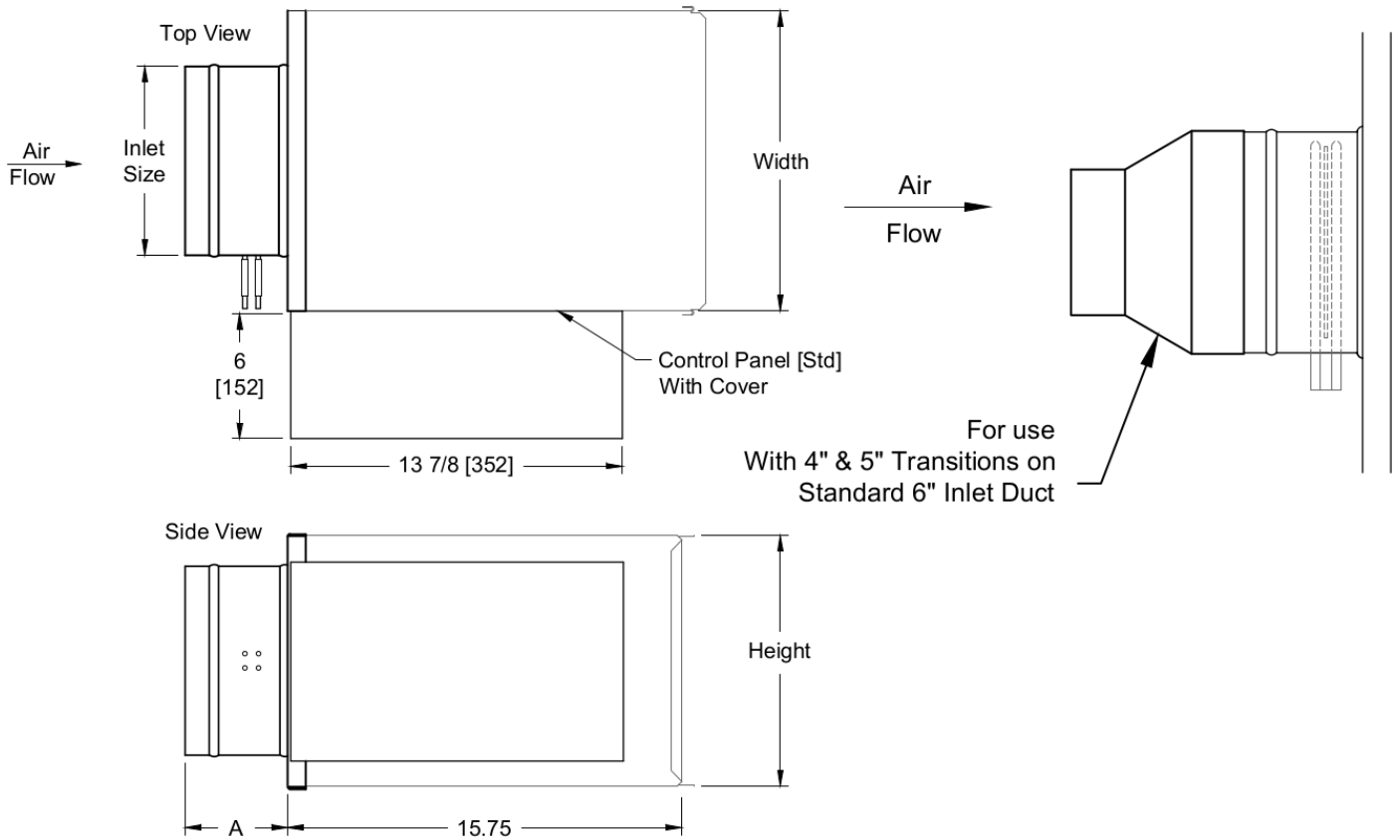

Model Number	Inlet Size		A		Width		Height		Unit wt.			
	in.	mm.	in.	mm.	in.	mm.	in.	mm.	lb.	kg.		
TH504	3 7/8	99	10	254	12	305	8	203	12	5		
TH505	4 7/8	124	10	254	12	305	8	203	12	5		
TH506	5 7/8	149	5	127	12	305	8	203	12	5		
TH508	7 7/8	200	5	127	12	305	10	254	15	7		
TH510	9 7/8	251	5	127	14	356	12 1/2	318	18	8		
TH512	11 7/8	302	5	127	16	406	15	381	22	10		
TH514	13 7/8	353	5	127	20	508	17 1/2	445	24	11		
TH516	15 7/8	403	5	127	24	610	18	457	29	13		
TH520	19 7/8	x	505	x	6	127	30	762	20	508	47	21
	15 7/8		403									
TH524	23 7/8	x	607	x	6	127	38	965	20	508	58	26
	15 7/8		403									

The standard location for control panel is Right Hand on Model TH. Looking in the direction of airflow, the control panel is on the right.

The control panel will overhang the top and bottom of Models TH504 - TH506 1" [46 mm] Control Panel Mounting Surface width by height is 13⁷/₈" x 9³/₄"

Mechanical Specifications

Tag(s): VAV-Cooling Only,VAV-1S-2

General

Furnish and install Single Duct Air Terminal Units. The units shall be the size and capacity as outlined in the plans and specifications. Casing dimensions shall be checked to ensure the terminals fit the available space.

Quality, Agency, Standards

Air terminals shall be certified under the Air Conditioning, Heating and Refrigeration Institute (AHRI) Standard 880-08 Certification Program and carry the AHRI seal. All NC values shall be calculated per AHRI Standard 885-08. Units with NC values calculated per AHRI-885-90 or 98 will not be accepted. Terminal units shall be either ETL® or UL® listed as a complete assembly. Terminal electrical components, including actuators and low voltage controls shall be UL® listed. All electrical components including both line voltage and low voltage shall be mounted in a metal control enclosure. Units shall have a single point field wiring connection. Units shall be manufactured and wired per UL-1995 and in accordance with the National Electric Code.

Shipping

All terminals shall be shipped as a single unit requiring no field assembly. Accessories including hot water coils and electric heaters shall be factory mounted.

Sound Rating

The terminal manufacturer shall provide AHRI certified sound power data for radiated and discharge sound. All NC values shall be calculated per AHRI standard 885-98. Verify sound ratings for the terminal do not exceed specified value at scheduled static pressure. Sound performance shall be AHRI certified. Each individual terminal unit shall bear an AHRI label.

Casing Material : 22 Ga Construction

The terminal casing shall be constructed of minimum 22 gauge galvanized steel.

Outlet : Slip and Drive Connection

Air terminals shall have a slip and drive connection on the discharge.

Liner : 1/2" Fiberglass 1 1/2 lbs.

Air Terminals shall be internally insulated with (1/2") thick, 1.5 lb. /ft³, dual density fiberglass. Insulation and edges shall be coated to prevent air erosion to 6000FPM surface velocity. Insulation shall comply with UL 181 and NFPA 90A.

Handing : Handing- Control And Reheat(electric or water) Connections On Right

Air terminals shall have the controls and reheat connections located on the right side when looking in the direction of the air flow.

Airflow Sensor : Multi Quadrant Averaging Flow Sensor

The inlet flow sensor shall be a multi-point quadrant averaging flow sensor.

Control Enclosure : Enclosure & Mounting Plate, Std Control Panel Enclosure and Std. Mntg Plate

Air terminals shall have a control enclosure and a control mounting plate with offsets to prevent penetration of the air terminal casing when installing controls.

Toggle Switch : Toggle Disconnect Switch

Fan powered terminals shall have a toggle disconnect switch to de-energize the fan motor.

Product Data: High Performance Single Duct Air Terminal Unit

Qty	Description	Model Number
3	High Performance Single Duct Air Terminal Unit	TH 5 08 1.50 STU SA EH C HS1 ZB1 C3 D1 ZA1D ZP3 Z07 Z82 Z55 Z91 Z23 USR 105E Z01

Tag(s): VRH-1N-1, VRH-5N-1, VRH-5S-1

Selected Options

- 08** Inlet Size : Inlet Size 08 (Min: 100 /Max: 990 CFM)
- STU Eco Low Leakage Series : Standard Terminal Unit
- SA Sound Attenuator : Discharge Attenuator
- EH Heating Type : Electric Heating Option
- C Volt Phase : 277-1-60
- HS1 Heat Steps : 1 Step
- ZB1 Transformer Fusing : Transformer with No Fusing
- C3 Disconnect Fusing : Line Disconnect Fusing
- D1 Disconnect : Door Interlocking Non-Fused Line Disconnect Switch
- ZA1D Contactors : Magnetic Contactors per Step
- ZP3 Electric Heating Enclosure : Standard Electric Heat Enclosure
- Z07 Casing Material : 22 Ga Construction
- Z82 Outlet : Slip and Drive Connection
- Z55 Liner : 1/2" Fiberglass 1 1/2 lbs.
- Z91 Handing : Handing- Control And Reheat(electric or water) Connections On Right
- Z23 Airflow Sensor : Multi Quadrant Averaging Flow Sensor
- USR Control Type (Select Control Sequence Second) : Controls by Other Factory Mounted
- 105E Control Sequence (Select Control Type First) : 105E - Factory Mounted Controls- Electric Heat and trans
- Z01 Control Enclosure : Enclosure & Mounting Plate, Std Control Panel Enclosure and Std. Mntg Plate

Product Data: High Performance Single Duct Air Terminal Unit

Qty	Description	Model Number
1	High Performance Single Duct Air Terminal Unit	TH 5 06 1.00 STU SA EH C HS1 ZB1 C3 D1 ZA1D ZP3 Z07 Z82 Z55 Z91 Z23 USR 105E Z01

Tag(s): VRH-2S-1

Selected Options

- 06** Inlet Size : Inlet Size 06 (Min: 55 /Max: 540 CFM)
- STU Eco Low Leakage Series : Standard Terminal Unit
- SA Sound Attenuator : Discharge Attenuator
- EH Heating Type : Electric Heating Option
- C Volt Phase : 277-1-60
- HS1 Heat Steps : 1 Step
- ZB1 Transformer Fusing : Transformer with No Fusing
- C3 Disconnect Fusing : Line Disconnect Fusing
- D1 Disconnect : Door Interlocking Non-Fused Line Disconnect Switch
- ZA1D Contactors : Magnetic Contactors per Step
- ZP3 Electric Heating Enclosure : Standard Electric Heat Enclosure
- Z07 Casing Material : 22 Ga Construction
- Z82 Outlet : Slip and Drive Connection
- Z55 Liner : 1/2" Fiberglass 1 1/2 lbs.
- Z91 Handing : Handing- Control And Reheat(electric or water) Connections On Right
- Z23 Airflow Sensor : Multi Quadrant Averaging Flow Sensor
- USR Control Type (Select Control Sequence Second) : Controls by Other Factory Mounted
- 105E Control Sequence (Select Control Type First) : 105E - Factory Mounted Controls- Electric Heat and trans
- Z01 Control Enclosure : Enclosure & Mounting Plate, Std Control Panel Enclosure and Std. Mntg Plate

METALAIRE™

**Model
TH-508**

Project: IBP XVIII

Tag: VRH-1N-1

Altitude: 0 Feet

Qty	Mode	Unit	Size		CFM			Static Pressure			Max NC Levels	
			Unit	Outlet	Max	Min	Inlet	Downstream	Min Drop	Unit Drop	Rad	Dis
1	TH	08	12x10	990	100	1.00	0.250	0.090	0.090	20	21	
						0						

Electric Heat:

Total Capacity:	Heating Airflow:	Entering Air Temp:	Leaving Air Temp:	Box Leaving Air Temp:	Volt / Phase:	Steps:
1.50 KW	210 CFM	55.00 °F	77.57 °F	77.57 °F	277-1	1 Step



High Performance Single Duct Air Terminal Unit

Electrical Data

Min. Cir. Amps - MCA	MOCP
6.77	15.00

Design Air Flow

Max Primary:	700 CFM
Min Primary:	210 CFM
Primary Heating Airflow:	210 CFM

Accessories:

Heating Coil:	EH
Inlet:	No Attenuator
Outlet:	Attenuator

Radiated Sound Power Level (db)

Discharge Sound Power Level (db)

Band	2	3	4	5	6	7	NC	Band	2	3	4	5	6	7	NC
Primary	58	50	42	37	30	25		Primary	70	64	50	39	32	32	
Total Attenuation	18	19	20	26	31	36		Total Attenuation	29	30	41	51	52	39	
Room Sound Level	40	31	22	11	0	0	20	Room Sound Level	41	34	9	0	0	0	21

METALAIRE™

**Model
TH-506**

Project: IBP XVIII

Tag: VRH-2S-1

Altitude: 0 Feet

Qty	Mode	Unit	Size		CFM					Static Pressure		Max NC Levels	
			Inlet	Outlet	Max	Min	Inlet	Downstream	Min Drop	Unit Drop	Rad	Dis	
1	TH	06	12x8	540	55	1.00	0.250	0.071	0.071	18	0		



High Performance Single Duct Air Terminal Unit

Electric Heat:

Total Capacity:	Heating Airflow:	Entering Air Temp:	Leaving Air Temp:	Box Leaving Air Temp:	Volt / Phase:	Steps:
1.00 KW	100 CFM	55.00 °F	86.60 °F	86.60 °F	277-1	1 Step

Electrical Data

Min. Cir. Amps - MCA	MOCP
4.51	15.00

Design Air Flow

Max Primary:	300 CFM
Min Primary:	100 CFM
Primary Heating Airflow:	100 CFM

Accessories:

Heating Coil:	EH
Inlet:	No Attenuator
Outlet:	Attenuator

Radiated Sound Power Level (db)

Discharge Sound Power Level (db)

Band	2	3	4	5	6	7	NC	Band	2	3	4	5	6	7	NC
Primary	54	47	44	36	33	31		Primary	62	55	46	30	22	26	
Total Attenuation	18	19	20	26	31	36		Total Attenuation	27	29	40	51	53	39	
Room Sound Level	36	28	24	10	2	0	18	Room Sound Level	35	26	6	0	0	0	< 15

METALAIR

**Model
TH-508**

Project: IBP XVIII

Tag: VRH-5N-1

Altitude: 0 Feet

Qty	Mode	Unit	Size		CFM				Static Pressure			Max NC Levels	
			Inlet	Outlet	Max	Min	Inlet	Downstream	Min Drop	Unit Drop	Rad	Dis	
1	TH	08	12x10	990	100	1.00	0.250	0.077	0.077	20	24		



High Performance Single Duct Air Terminal Unit

Electric Heat:

Total Capacity:	Heating Airflow:	Entering Air Temp:	Leaving Air Temp:	Box Leaving Air Temp:	Volt / Phase:	Steps:
1.50 KW	200 CFM	55.00 °F	78.70 °F	78.70 °F	277-1	1 Step

Electrical Data

Min. Cir. Amps - MCA	MOCP
6.77	15.00

Design Air Flow

Max Primary:	650 CFM
Min Primary:	100 CFM
Primary Heating Airflow:	200 CFM

Accessories:

Heating Coil:	EH
Inlet:	No Attenuator
Outlet:	Attenuator

Radiated Sound Power Level (db)

Discharge Sound Power Level (db)

Band	2	3	4	5	6	7	NC	Band	2	3	4	5	6	7	NC
Primary	58	49	41	36	29	24		Primary	70	63	49	38	31	31	
Total Attenuation	18	19	20	26	31	36		Total Attenuation	27	29	40	51	53	39	
Room Sound Level	40	30	21	10	0	0	20	Room Sound Level	43	34	9	0	0	0	24

METALAIRE™

**Model
TH-508**

Project: IBP XVIII

Tag: VRH-5S-1

Altitude: 0 Feet

Qty	Mode	Unit	Size		CFM					Static Pressure		Max NC Levels	
			Inlet	Outlet	Max	Min	Inlet	Downstream	Min Drop	Unit Drop	Rad	Dis	
1	TH	08	12x10	990	100	1.00	0.250	0.077	0.077	20	24		



High Performance Single Duct Air Terminal Unit

Electric Heat:

Total Capacity:	Heating Airflow:	Entering Air Temp:	Leaving Air Temp:	Box Leaving Air Temp:	Volt / Phase:	Steps:
1.50 KW	200 CFM	55.00 °F	78.70 °F	78.70 °F	277-1	1 Step

Electrical Data

Min. Cir. Amps - MCA	MOCP
6.77	15.00

Design Air Flow

Max Primary:	650 CFM
Min Primary:	100 CFM
Primary Heating Airflow:	200 CFM

Accessories:

Heating Coil:	EH
Inlet:	No Attenuator
Outlet:	Attenuator

Radiated Sound Power Level (db)

Discharge Sound Power Level (db)

Band	2	3	4	5	6	7	NC	Band	2	3	4	5	6	7	NC
Primary	58	49	41	36	29	24		Primary	70	63	49	38	31	31	
Total Attenuation	18	19	20	26	31	36		Total Attenuation	27	29	40	51	53	39	
Room Sound Level	40	30	21	10	0	0	20	Room Sound Level	43	34	9	0	0	0	24

TH500-003 - TH with Integral Attenuator and EH

Qty: 4 Tags: VRH-1N-1, VRH-5N-1, VRH-5S-1, VRH-2S-1

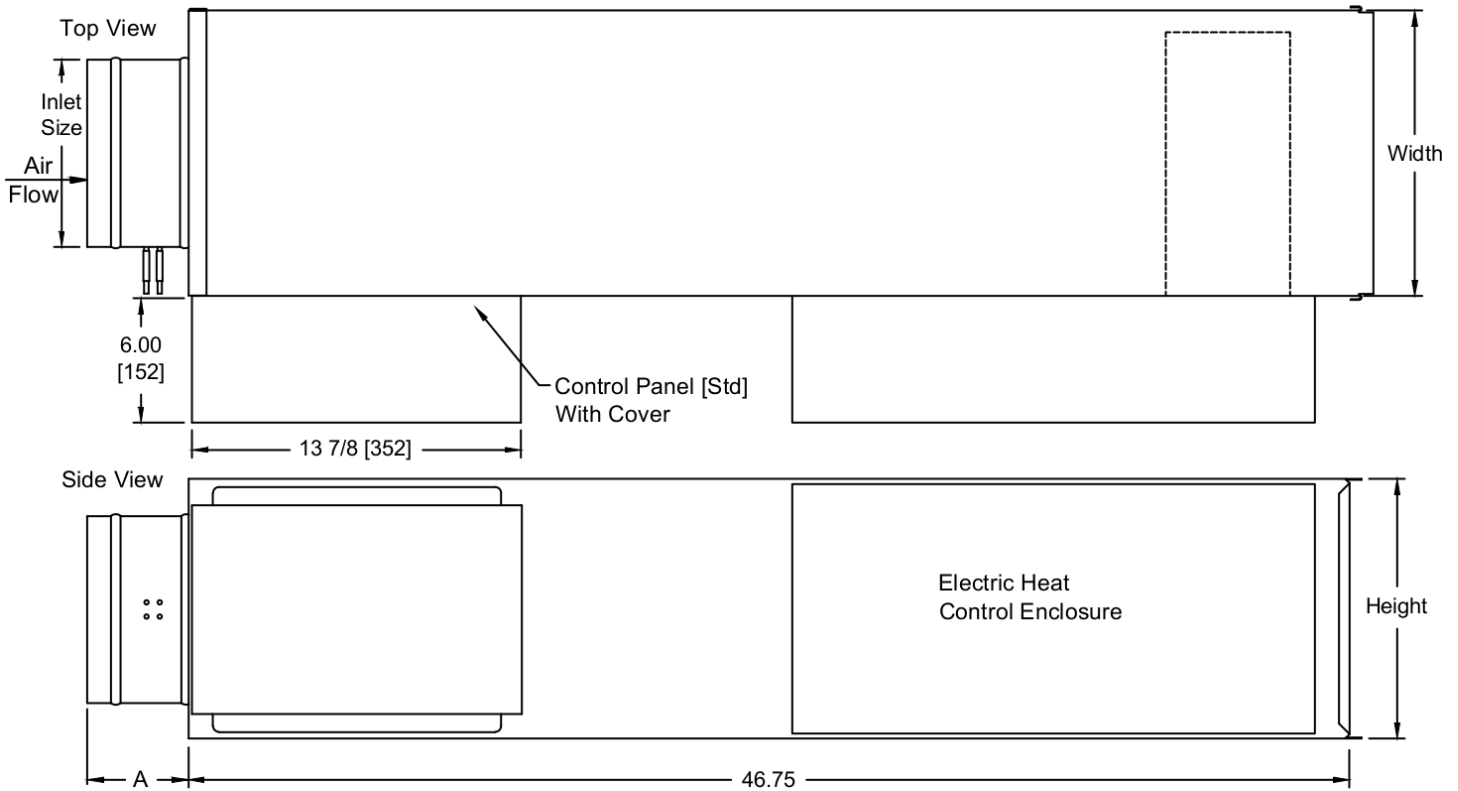

The standard location for control panel is Right Hand on Model TH. Looking in the direction of airflow, the control panel is on the right.

The control panel will overhang the top and bottom of Models TH504 - TH506 $1 \frac{13}{16}$ " [46 mm] or $\frac{13}{16}$ " [20 mm] on TH508 Control Panel Mounting Surface width by height is $13 \frac{7}{8}$ " x $9 \frac{3}{4}$ "

Model Number	Inlet Duct				Unit					
	Nominal Size		A		Width		Height		Unit wt.	
	in.	mm.	in.	mm.	in.	mm.	in.	mm.	lb.	kg.
TH504	3 7/8	99	10	254	12	305	8	203	38	17
TH505	4 7/8	124	10	254	12	305	8	203	38	17
TH506	5 7/8	149	5	127	12	305	8	203	38	17
TH508	7 7/8	200	5	127	12	305	10	254	43	20
TH510	9 7/8	251	5	127	14	356	12 1/2	318	50	23
TH512	11 7/8	302	5	127	16	406	15	381	59	27
TH514	13 7/8	353	5	127	20	508	17 1/2	445	67	30
TH516	15 7/8	403	5	127	24	610	18	457	77	35
TH520	19 7/8 x	505 x	6	127	30	762	20	508	103	47
	15 7/8	403								
TH524	23 7/8 x	607 x	6	127	38	965	20	508	122	55
	15 7/8	403								

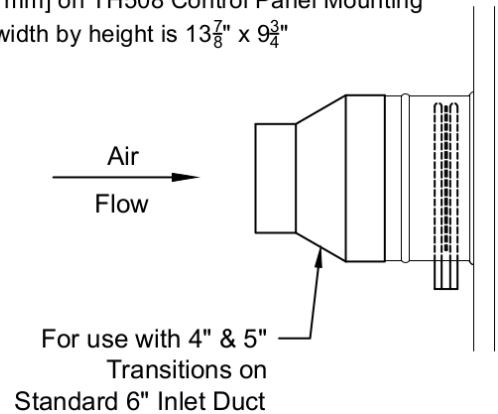

Mechanical Specifications

Tag(s): VRH-1N-1,VRH-2S-1,VRH-5N-1,VRH-5S-1

General

Furnish and install Single Duct Air Terminal Units. The units shall be the size and capacity as outlined in the plans and specifications. Casing dimensions shall be checked to ensure the terminals fit the available space.

Quality, Agency, Standards

Air terminals shall be certified under the Air Conditioning, Heating and Refrigeration Institute (AHRI) Standard 880-08 Certification Program and carry the AHRI seal. All NC values shall be calculated per AHRI Standard 885-08. Units with NC values calculated per AHRI-885-90 or 98 will not be accepted. Terminal units shall be either ETL® or UL® listed as a complete assembly. Terminal electrical components, including actuators and low voltage controls shall be UL® listed. All electrical components including both line voltage and low voltage shall be mounted in a metal control enclosure. Units shall have a single point field wiring connection. Units shall be manufactured and wired per UL-1995 and in accordance with the National Electric Code.

Shipping

All terminals shall be shipped as a single unit requiring no field assembly. Accessories including hot water coils and electric heaters shall be factory mounted.

Sound Rating

The terminal manufacturer shall provide AHRI certified sound power data for radiated and discharge sound. All NC values shall be calculated per AHRI standard 885-98. Verify sound ratings for the terminal do not exceed specified value at scheduled static pressure. Sound performance shall be AHRI certified. Each individual terminal unit shall bear an AHRI label.

Casing Material : 22 Ga Construction

The terminal casing shall be constructed of minimum 22 gauge galvanized steel.

Outlet : Slip and Drive Connection

Air terminals shall have a slip and drive connection on the discharge.

Liner : 1/2" Fiberglass 1 1/2 lbs.

Air Terminals shall be internally insulated with (1/2") thick, 1.5 lb. /ft³, dual density fiberglass. Insulation and edges shall be coated to prevent air erosion to 6000FPM surface velocity. Insulation shall comply with UL 181 and NFPA 90A.

Handing : Handing- Control And Reheat(electric or water) Connections On Right

Air terminals shall have the controls and reheat connections located on the right side when looking in the direction of the air flow.

Airflow Sensor : Multi Quadrant Averaging Flow Sensor

The inlet flow sensor shall be a multi-point quadrant averaging flow sensor.

Control Enclosure : Enclosure & Mounting Plate, Std Control Panel Enclosure and Std. Mntg Plate

Air terminals shall have a control enclosure and a control mounting plate with offsets to prevent penetration of the air terminal casing when installing controls.

Product Data: Series Fan Powered Air Terminal Unit

Qty	Description	Model Number
5	Series Fan Powered Air Terminal Unit	FCI C2 6 08 4.00 C EH N HS1 ZB1 C3 D1 ZA1D ZP3 Z22 Z10 32 NIA Z02 Z49 Z88 Z23 82 USR 905E

Tag(s): CV-1N-1, CV-2N-1, CV-3N-1, CV-4N-1, CV-5N-1

Selected Options

- C2 Unit Case Size : Case Size 2
- 08 Inlet Size : Inlet Size 08 (Min: 100 /Max: 990 CFM)
- C Fan Voltage : 277 V
- EH Heating Type : Electric Heating
- N Volt Phase : 480-3-60
- HS1 Heat Steps : 1 Step
- ZB1 Transformer Fusing : Transformer with No Fusing
- C3 Disconnect Fusing : Line Disconnect Fusing
- D1 Disconnect : Door Interlocking Non-Fused Line Disconnect Switch
- ZA1D Contactors : Magnetic Contactors per Step
- ZP3 Electric Heating Enclosure : Standard Electric Heat Enclosure
- Z22 Fan Motor : PSC Fan Motor, Permanent Split Capacitor fan motor
- Z10 Casing Material : Construction- 20 Ga construction
- 32 Filter Rack : Filter Rack with 1" Filter
- NIA Attenuator : No Attenuator
- Z02 Fan Access Door : Bottom Mount Fan Motor Access Door, Zip Screw
- Z49 Liner : 1" Fiberglass 1 1/2 lbs.
- Z88 Handing : Handing- Control And Reheat(electric or water) Connections On Left
- Z23 Airflow Sensor : Multi Quadrant Averaging Flow Sensor
- 82 Outlet : Slip and Drive Connection
- USR Control Type (Select Control Sequence Second) : Controls by Other Factory Mounted
- 905E Control Sequence (Select Control Type First) : 905E - Factory Mounted Controls- Electric Heat and trans

Product Data: Series Fan Powered Air Terminal Unit

Qty	Description	Model Number
5	Series Fan Powered Air Terminal Unit	FCI C2 6 06 3.00 C EH N HS1 ZB1 C3 D1 ZA1D ZP3 Z22 Z10 32 NIA Z02 Z49 Z88 Z23 82 USR 905E

Tag(s): CV-1S-1, CV-2S-1, CV-3S-1, CV-4S-1, CV-5S-1

Selected Options

- C2 Unit Case Size : Case Size 2
- 06 Inlet Size : Inlet Size 06 (Min: 55 /Max: 540 CFM)
- C Fan Voltage : 277 V
- EH Heating Type : Electric Heating
- N Volt Phase : 480-3-60
- HS1 Heat Steps : 1 Step
- ZB1 Transformer Fusing : Transformer with No Fusing
- C3 Disconnect Fusing : Line Disconnect Fusing
- D1 Disconnect : Door Interlocking Non-Fused Line Disconnect Switch
- ZA1D Contactors : Magnetic Contactors per Step
- ZP3 Electric Heating Enclosure : Standard Electric Heat Enclosure
- Z22 Fan Motor : PSC Fan Motor, Permanent Split Capacitor fan motor
- Z10 Casing Material : Construction- 20 Ga construction
- 32 Filter Rack : Filter Rack with 1" Filter
- NIA Attenuator : No Attenuator
- Z02 Fan Access Door : Bottom Mount Fan Motor Access Door, Zip Screw
- Z49 Liner : 1" Fiberglass 1 1/2 lbs.
- Z88 Handing : Handing- Control And Reheat(electric or water) Connections On Left
- Z23 Airflow Sensor : Multi Quadrant Averaging Flow Sensor
- 82 Outlet : Slip and Drive Connection
- USR Control Type (Select Control Sequence Second) : Controls by Other Factory Mounted
- 905E Control Sequence (Select Control Type First) : 905E - Factory Mounted Controls- Electric Heat and trans

METALAIRE™

**Model
FCI-C2-608**

Project: IBP XVIII

Tag: CV-1N-1

Altitude: 0 Feet

Qty	Mode	Case	Size			CFM			Static Pressure			Max NC Levels	
			Unit	Outlet	Max	Min	Inlet	Downstream	Min Drop	Unit Drop	Rad	Dis	
1	FCI	C2	08	16x15	990	100	1.00	0.250	0.034	0.034	26	18	



Series Fan Powered Air Terminal Unit

Fan Data:

Max Fan Airflow:	Min Fan Airflow:	Motor Type:	Fan HP:	External Static Pressure:	Fan Voltage:	FLA:	MCA:	MOCP:
740 CFM	175 CFM	PSC	1/8	0.25 in. H2O	277/1	1.10	7.39	15.00

Electric Heat:

Total Capacity:	Heating Airflow:	Entering Air Temp:	Leaving Air Temp:	Box Leaving Air Temp:	Volt / Phase:	Steps:
4.00 KW	420 CFM	55.00 °F	95.00 °F	95.00 °F	480-3	1 Step

Electrical Data

Min. Cir. Amps - MCA	MOCP
7.39	15.00

Design Air Flow

Max Primary:	420 CFM
Min Primary:	100 CFM
Fan Airflow:	420 CFM
Primary Heating Airflow:	100 CFM

Accessories:

Heating Coil:	EH
Inlet:	No Attenuator
Outlet:	No Attenuator

Fan Curve

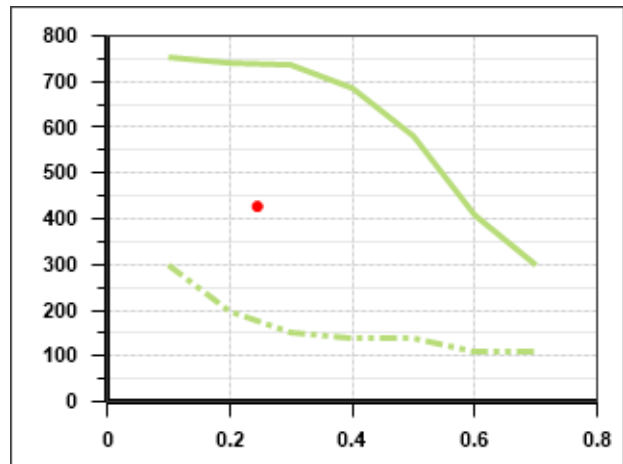

Radiated Sound Power Level (db)

Band	2	3	4	5	6	7	NC
Fan + Primary	57	56	52	41	42	42	
Total Attenuation	18	19	20	26	31	36	
Room Sound Level	39	37	32	15	11	6	26

Discharge Sound Power Level (db)

Band	2	3	4	5	6	7	NC
Fan + Primary	60	60	60	52	50	46	
Total Attenuation	27	29	40	51	53	39	
Room Sound Level	33	31	20	1	0	7	18

METALAIRE™

**Model
FCI-C2-606**

Project: IBP XVIII

Tag: CV-1S-1

Altitude: 0 Feet

Qty	Mode	Case	Size			CFM			Static Pressure			Max NC Levels	
			Unit	Outlet	Max	Min	Inlet	Downstream	Min Drop	Unit Drop	Rad	Dis	
1	FCI	C2	06	16x15	540	55	1.00	0.250	0.017	0.017	24	18	



Series Fan Powered Air Terminal Unit

Fan Data:

Max Fan Airflow:	Min Fan Airflow:	Motor Type:	Fan HP:	External Static Pressure:	Fan Voltage:	FLA:	MCA:	MOCP:
740 CFM	175 CFM	PSC	1/8	0.25 in. H2O	277/1	1.10	5.89	15.00

Electric Heat:

Total Capacity:	Heating Airflow:	Entering Air Temp:	Leaving Air Temp:	Box Leaving Air Temp:	Volt / Phase:	Steps:
3.00 KW	300 CFM	55.00 °F	95.27 °F	95.27 °F	480-3	1 Step

Electrical Data

Min. Cir. Amps - MCA	MOCP
5.89	15.00

Design Air Flow

Max Primary:	300 CFM
Min Primary:	100 CFM
Fan Airflow:	300 CFM
Primary Heating Airflow:	100 CFM

Accessories:

Heating Coil:	EH
Inlet:	No Attenuator
Outlet:	No Attenuator

Fan Curve

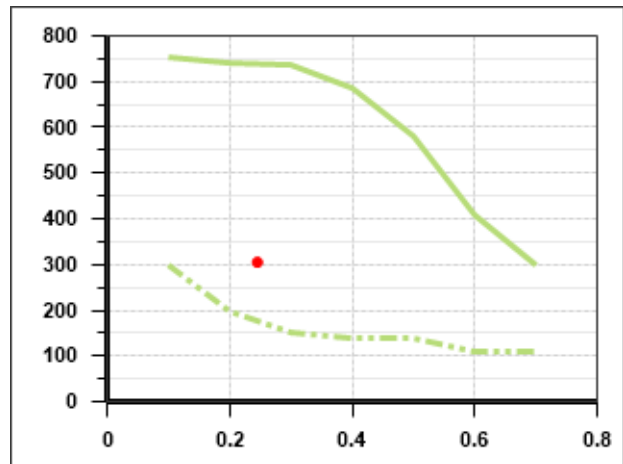

Radiated Sound Power Level (db)

Band	2	3	4	5	6	7	NC
Fan + Primary	55	54	50	39	40	39	
Total Attenuation	18	19	20	26	31	36	
Room Sound Level	37	35	30	13	9	3	24

Discharge Sound Power Level (db)

Band	2	3	4	5	6	7	NC
Fan + Primary	58	60	58	50	48	44	
Total Attenuation	27	29	40	51	53	39	
Room Sound Level	31	31	18	0	0	5	18

METALAIRE™

**Model
FCI-C2-608**

Project: IBP XVIII

Tag: CV-2N-1

Altitude: 0 Feet

Qty	Mode	Case	Size			CFM			Static Pressure			Max NC Levels	
			Unit	Outlet	Max	Min	Inlet	Downstream	Min Drop	Unit Drop	Rad	Dis	
1	FCI	C2	08	16x15	990	100	1.00	0.250	0.034	0.034	26	18	



Series Fan Powered Air Terminal Unit

Fan Data:

Max Fan Airflow:	Min Fan Airflow:	Motor Type:	Fan HP:	External Static Pressure:	Fan Voltage:	FLA:	MCA:	MOCP:
740 CFM	175 CFM	PSC	1/8	0.25 in. H2O	277/1	1.10	7.39	15.00

Electric Heat:

Total Capacity:	Heating Airflow:	Entering Air Temp:	Leaving Air Temp:	Box Leaving Air Temp:	Volt / Phase:	Steps:
4.00 KW	420 CFM	55.00 °F	95.00 °F	95.00 °F	480-3	1 Step

Electrical Data

Min. Cir. Amps - MCA	MOCP
7.39	15.00

Design Air Flow

Max Primary:	420 CFM
Min Primary:	100 CFM
Fan Airflow:	420 CFM
Primary Heating Airflow:	100 CFM

Accessories:

Heating Coil:	EH
Inlet:	No Attenuator
Outlet:	No Attenuator

Fan Curve

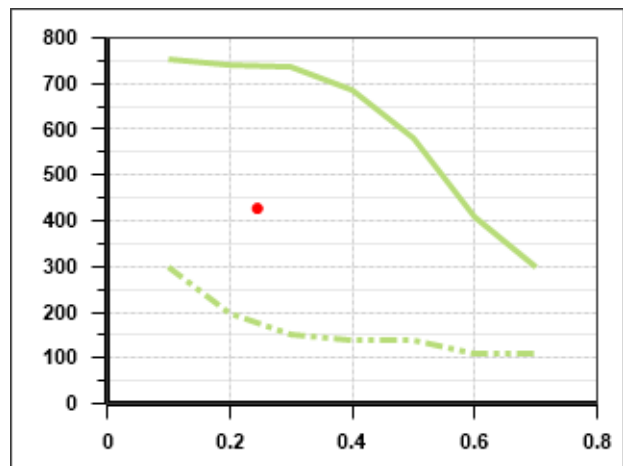

Radiated Sound Power Level (db)

Band	2	3	4	5	6	7	NC
Fan + Primary	57	56	52	41	42	42	
Total Attenuation	18	19	20	26	31	36	
Room Sound Level	39	37	32	15	11	6	26

Discharge Sound Power Level (db)

Band	2	3	4	5	6	7	NC
Fan + Primary	60	60	60	52	50	46	
Total Attenuation	27	29	40	51	53	39	
Room Sound Level	33	31	20	1	0	7	18

METALAIRE™

**Model
FCI-C2-606**

Project: IBP XVIII

Tag: CV-2S-1

Altitude: 0 Feet

Qty	Mode	Case	Size			CFM			Static Pressure			Max NC Levels	
			Unit	Outlet	Max	Min	Inlet	Downstream	Min Drop	Unit Drop	Rad	Dis	
1	FCI	C2	06	16x15	540	55	1.00	0.250	0.017	0.017	24	18	



Series Fan Powered Air Terminal Unit

Fan Data:

Max Fan Airflow:	Min Fan Airflow:	Motor Type:	Fan HP:	External Static Pressure:	Fan Voltage:	FLA:	MCA:	MOCP:
740 CFM	175 CFM	PSC	1/8	0.25 in. H2O	277/1	1.10	5.89	15.00

Electric Heat:

Total Capacity:	Heating Airflow:	Entering Air Temp:	Leaving Air Temp:	Box Leaving Air Temp:	Volt / Phase:	Steps:
3.00 KW	300 CFM	55.00 °F	95.27 °F	95.27 °F	480-3	1 Step

Electrical Data

Min. Cir. Amps - MCA	MOCP
5.89	15.00

Design Air Flow

Max Primary:	300 CFM
Min Primary:	100 CFM
Fan Airflow:	300 CFM
Primary Heating Airflow:	100 CFM

Accessories:

Heating Coil:	EH
Inlet:	No Attenuator
Outlet:	No Attenuator

Fan Curve

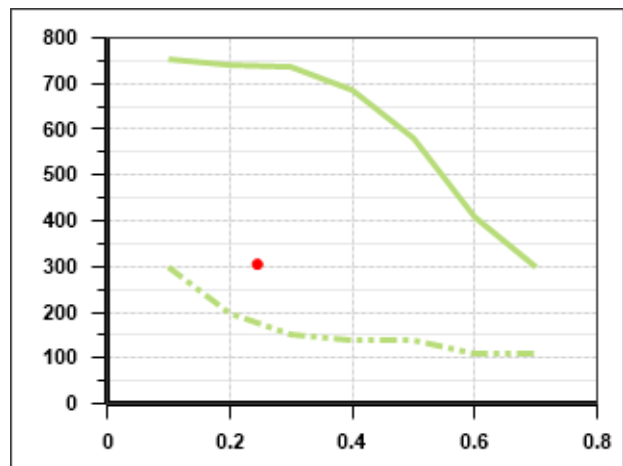

Radiated Sound Power Level (db)

Band	2	3	4	5	6	7	NC
Fan + Primary	55	54	50	39	40	39	
Total Attenuation	18	19	20	26	31	36	
Room Sound Level	37	35	30	13	9	3	24

Discharge Sound Power Level (db)

Band	2	3	4	5	6	7	NC
Fan + Primary	58	60	58	50	48	44	
Total Attenuation	27	29	40	51	53	39	
Room Sound Level	31	31	18	0	0	5	18

METALAIR

Model
FCI-C2-608

Project: IBP XVIII

Tag: CV-3N-1

Altitude: 0 Feet

Qty	Mode	Case	Size			CFM			Static Pressure			Max NC Levels	
			Unit	Outlet	Max	Min	Inlet	Downstream	Min Drop	Unit Drop	Rad	Dis	
1	FCI	C2	08	16x15	990	100	1.00	0.250	0.034	0.034	26	18	



Series Fan Powered Air Terminal Unit

Fan Data:

Max Fan Airflow:	Min Fan Airflow:	Motor Type:	Fan HP:	External Static Pressure:	Fan Voltage:	FLA:	MCA:	MOCP:
740 CFM	175 CFM	PSC	1/8	0.25 in. H2O	277/1	1.10	7.39	15.00

Electric Heat:

Total Capacity:	Heating Airflow:	Entering Air Temp:	Leaving Air Temp:	Box Leaving Air Temp:	Volt / Phase:	Steps:
4.00 KW	420 CFM	55.00 °F	95.00 °F	95.00 °F	480-3	1 Step

Electrical Data

Min. Cir. Amps - MCA	MOCP
7.39	15.00

Design Air Flow

Max Primary:	420 CFM
Min Primary:	100 CFM
Fan Airflow:	420 CFM
Primary Heating Airflow:	100 CFM

Accessories:

Heating Coil:	EH
Inlet:	No Attenuator
Outlet:	No Attenuator

Fan Curve

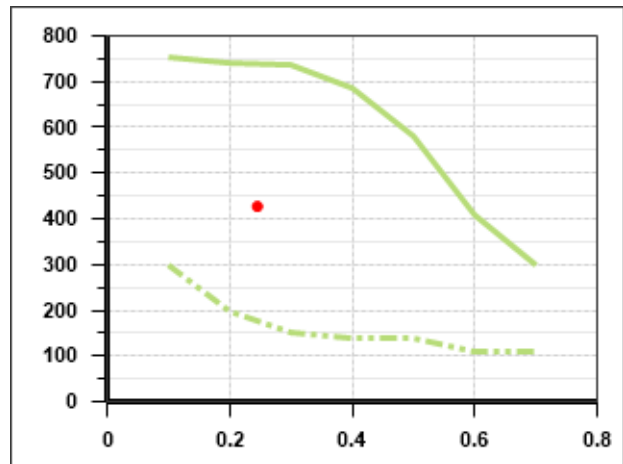

Radiated Sound Power Level (db)

Band	2	3	4	5	6	7	NC
Fan + Primary	57	56	52	41	42	42	
Total Attenuation	18	19	20	26	31	36	
Room Sound Level	39	37	32	15	11	6	26

Discharge Sound Power Level (db)

Band	2	3	4	5	6	7	NC
Fan + Primary	60	60	60	52	50	46	
Total Attenuation	27	29	40	51	53	39	
Room Sound Level	33	31	20	1	0	7	18

METALAIRE™

**Model
FCI-C2-606**

Project: IBP XVIII

Tag: CV-3S-1

Altitude: 0 Feet

Qty	Mode	Case	Size			CFM			Static Pressure			Max NC Levels	
			Unit	Outlet	Max	Min	Inlet	Downstream	Min Drop	Unit Drop	Rad	Dis	
1	FCI	C2	06	16x15	540	55	1.00	0.250	0.017	0.017	24	18	



Series Fan Powered Air Terminal Unit

Fan Data:

Max Fan Airflow:	Min Fan Airflow:	Motor Type:	Fan HP:	External Static Pressure:	Fan Voltage:	FLA:	MCA:	MOCP:
740 CFM	175 CFM	PSC	1/8	0.25 in. H2O	277/1	1.10	5.89	15.00

Electric Heat:

Total Capacity:	Heating Airflow:	Entering Air Temp:	Leaving Air Temp:	Box Leaving Air Temp:	Volt / Phase:	Steps:
3.00 KW	300 CFM	55.00 °F	95.27 °F	95.27 °F	480-3	1 Step

Electrical Data

Min. Cir. Amps - MCA	MOCP
5.89	15.00

Design Air Flow

Max Primary:	300 CFM
Min Primary:	100 CFM
Fan Airflow:	300 CFM
Primary Heating Airflow:	100 CFM

Accessories:

Heating Coil:	EH
Inlet:	No Attenuator
Outlet:	No Attenuator

Fan Curve

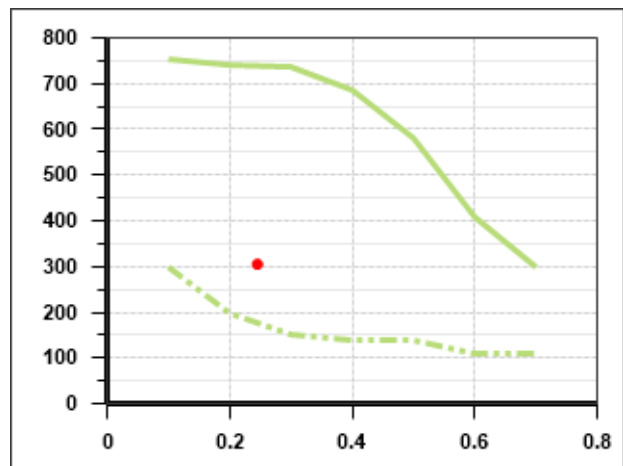

Radiated Sound Power Level (db)

Band	2	3	4	5	6	7	NC
Fan + Primary	55	54	50	39	40	39	
Total Attenuation	18	19	20	26	31	36	
Room Sound Level	37	35	30	13	9	3	24

Discharge Sound Power Level (db)

Band	2	3	4	5	6	7	NC
Fan + Primary	58	60	58	50	48	44	
Total Attenuation	27	29	40	51	53	39	
Room Sound Level	31	31	18	0	0	5	18

METALAIRE™

**Model
FCI-C2-608**

Project: IBP XVIII

Tag: CV-4N-1

Altitude: 0 Feet

Qty	Mode	Case	Size			CFM			Static Pressure			Max NC Levels	
			Unit	Outlet	Max	Min	Inlet	Downstream	Min Drop	Unit Drop	Rad	Dis	
1	FCI	C2	08	16x15	990	100	1.00	0.250	0.034	0.034	26	18	



Series Fan Powered Air Terminal Unit

Fan Data:

Max Fan Airflow:	Min Fan Airflow:	Motor Type:	Fan HP:	External Static Pressure:	Fan Voltage:	FLA:	MCA:	MOCP:
740 CFM	175 CFM	PSC	1/8	0.25 in. H2O	277/1	1.10	7.39	15.00

Electric Heat:

Total Capacity:	Heating Airflow:	Entering Air Temp:	Leaving Air Temp:	Box Leaving Air Temp:	Volt / Phase:	Steps:
4.00 KW	420 CFM	55.00 °F	95.00 °F	95.00 °F	480-3	1 Step

Electrical Data

Min. Cir. Amps - MCA	MOCP
7.39	15.00

Design Air Flow

Max Primary:	420 CFM
Min Primary:	100 CFM
Fan Airflow:	420 CFM
Primary Heating Airflow:	100 CFM

Accessories:

Heating Coil:	EH
Inlet:	No Attenuator
Outlet:	No Attenuator

Fan Curve

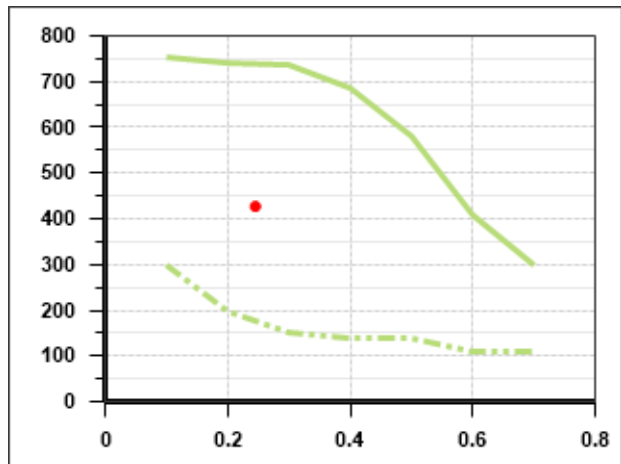

Radiated Sound Power Level (db)

Band	2	3	4	5	6	7	NC
Fan + Primary	57	56	52	41	42	42	
Total Attenuation	18	19	20	26	31	36	
Room Sound Level	39	37	32	15	11	6	26

Discharge Sound Power Level (db)

Band	2	3	4	5	6	7	NC
Fan + Primary	60	60	60	52	50	46	
Total Attenuation	27	29	40	51	53	39	
Room Sound Level	33	31	20	1	0	7	18

METALAIRE™

**Model
FCI-C2-606**

Project: IBP XVIII

Tag: CV-4S-1

Altitude: 0 Feet

Qty	Mode	Case	Size			CFM			Static Pressure			Max NC Levels	
			Unit	Outlet	Max	Min	Inlet	Downstream	Min Drop	Unit Drop	Rad	Dis	
1	FCI	C2	06	16x15	540	55	1.00	0.250	0.017	0.017	24	18	



Series Fan Powered Air Terminal Unit

Fan Data:

Max Fan Airflow:	Min Fan Airflow:	Motor Type:	Fan HP:	External Static Pressure:	Fan Voltage:	FLA:	MCA:	MOCP:
740 CFM	175 CFM	PSC	1/8	0.25 in. H2O	277/1	1.10	5.89	15.00

Electric Heat:

Total Capacity:	Heating Airflow:	Entering Air Temp:	Leaving Air Temp:	Box Leaving Air Temp:	Volt / Phase:	Steps:
3.00 KW	300 CFM	55.00 °F	95.27 °F	95.27 °F	480-3	1 Step

Electrical Data

Min. Cir. Amps - MCA	MOCP
5.89	15.00

Design Air Flow

Max Primary:	300 CFM
Min Primary:	100 CFM
Fan Airflow:	300 CFM
Primary Heating Airflow:	100 CFM

Accessories:

Heating Coil:	EH
Inlet:	No Attenuator
Outlet:	No Attenuator

Fan Curve

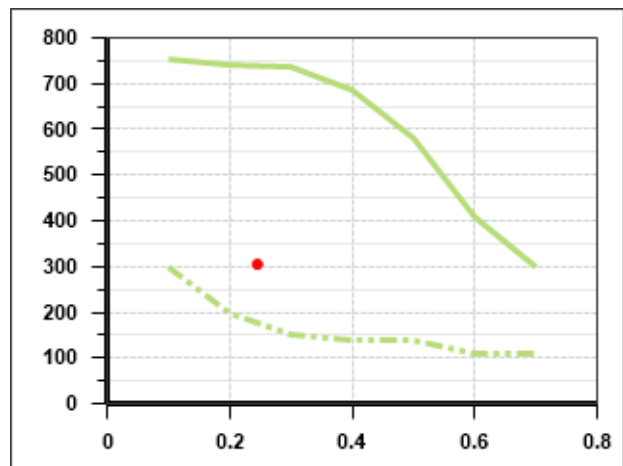

Radiated Sound Power Level (db)

Band	2	3	4	5	6	7	NC
Fan + Primary	55	54	50	39	40	39	
Total Attenuation	18	19	20	26	31	36	
Room Sound Level	37	35	30	13	9	3	24

Discharge Sound Power Level (db)

Band	2	3	4	5	6	7	NC
Fan + Primary	58	60	58	50	48	44	
Total Attenuation	27	29	40	51	53	39	
Room Sound Level	31	31	18	0	0	5	18

METALAIRE™

**Model
FCI-C2-608**

Project: IBP XVIII

Tag: CV-5N-1

Altitude: 0 Feet

Qty	Mode	Case	Size			CFM			Static Pressure			Max NC Levels	
			Unit	Outlet	Max	Min	Inlet	Downstream	Min Drop	Unit Drop	Rad	Dis	
1	FCI	C2	08	16x15	990	100	1.00	0.250	0.034	0.034	26	18	



Series Fan Powered Air Terminal Unit

Fan Data:

Max Fan Airflow:	Min Fan Airflow:	Motor Type:	Fan HP:	External Static Pressure:	Fan Voltage:	FLA:	MCA:	MOCP:
740 CFM	175 CFM	PSC	1/8	0.25 in. H2O	277/1	1.10	7.39	15.00

Electric Heat:

Total Capacity:	Heating Airflow:	Entering Air Temp:	Leaving Air Temp:	Box Leaving Air Temp:	Volt / Phase:	Steps:
4.00 KW	420 CFM	55.00 °F	95.00 °F	95.00 °F	480-3	1 Step

Electrical Data

Min. Cir. Amps - MCA	MOCP
7.39	15.00

Design Air Flow

Max Primary:	420 CFM
Min Primary:	100 CFM
Fan Airflow:	420 CFM
Primary Heating Airflow:	100 CFM

Accessories:

Heating Coil:	EH
Inlet:	No Attenuator
Outlet:	No Attenuator

Fan Curve

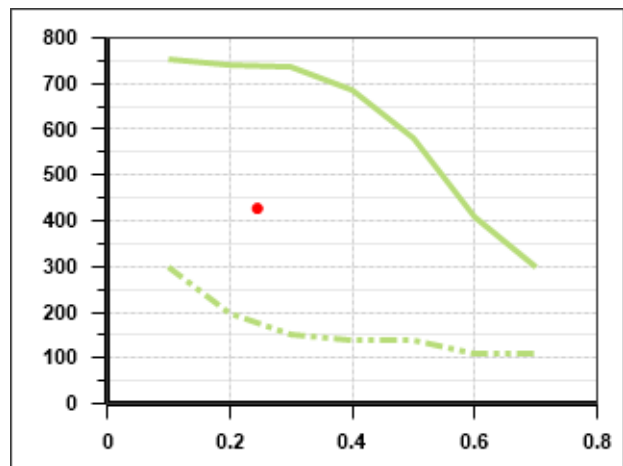

Radiated Sound Power Level (db)

Band	2	3	4	5	6	7	NC
Fan + Primary	57	56	52	41	42	42	
Total Attenuation	18	19	20	26	31	36	
Room Sound Level	39	37	32	15	11	6	26

Discharge Sound Power Level (db)

Band	2	3	4	5	6	7	NC
Fan + Primary	60	60	60	52	50	46	
Total Attenuation	27	29	40	51	53	39	
Room Sound Level	33	31	20	1	0	7	18

METALAIRE™

**Model
FCI-C2-606**

Project: IBP XVIII

Tag: CV-5S-1

Altitude: 0 Feet

Qty	Mode	Case	Size			CFM			Static Pressure			Max NC Levels	
			Unit	Outlet	Max	Min	Inlet	Downstream	Min Drop	Unit Drop	Rad	Dis	
1	FCI	C2	06	16x15	540	55	1.00	0.250	0.017	0.017	24	18	



Series Fan Powered Air Terminal Unit

Fan Data:

Max Fan Airflow:	Min Fan Airflow:	Motor Type:	Fan HP:	External Static Pressure:	Fan Voltage:	FLA:	MCA:	MOCP:
740 CFM	175 CFM	PSC	1/8	0.25 in. H2O	277/1	1.10	5.89	15.00

Electric Heat:

Total Capacity:	Heating Airflow:	Entering Air Temp:	Leaving Air Temp:	Box Leaving Air Temp:	Volt / Phase:	Steps:
3.00 KW	300 CFM	55.00 °F	95.27 °F	95.27 °F	480-3	1 Step

Electrical Data

Min. Cir. Amps - MCA	MOCP
5.89	15.00

Design Air Flow

Max Primary:	300 CFM
Min Primary:	100 CFM
Fan Airflow:	300 CFM
Primary Heating Airflow:	100 CFM

Accessories:

Heating Coil:	EH
Inlet:	No Attenuator
Outlet:	No Attenuator

Fan Curve

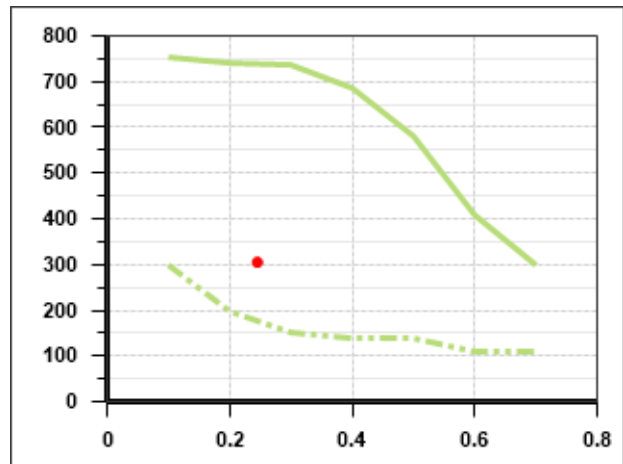

Radiated Sound Power Level (db)

Band	2	3	4	5	6	7	NC
Fan + Primary	55	54	50	39	40	39	
Total Attenuation	18	19	20	26	31	36	
Room Sound Level	37	35	30	13	9	3	24

Discharge Sound Power Level (db)

Band	2	3	4	5	6	7	NC
Fan + Primary	58	60	58	50	48	44	
Total Attenuation	27	29	40	51	53	39	
Room Sound Level	31	31	18	0	0	5	18

FCI600-003 - FCI with EH

Qty: 10 Tags: CV-1N-1, CV-2N-1, CV-3N-1, CV-4N-1, CV-5N-1, CV-1S-1, CV-2S-1, CV-3S-1, CV-4S-1, CV-5S-1

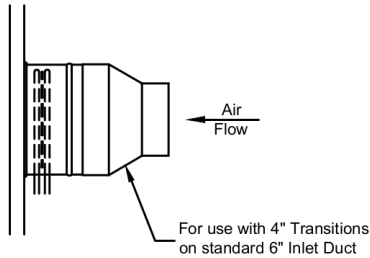
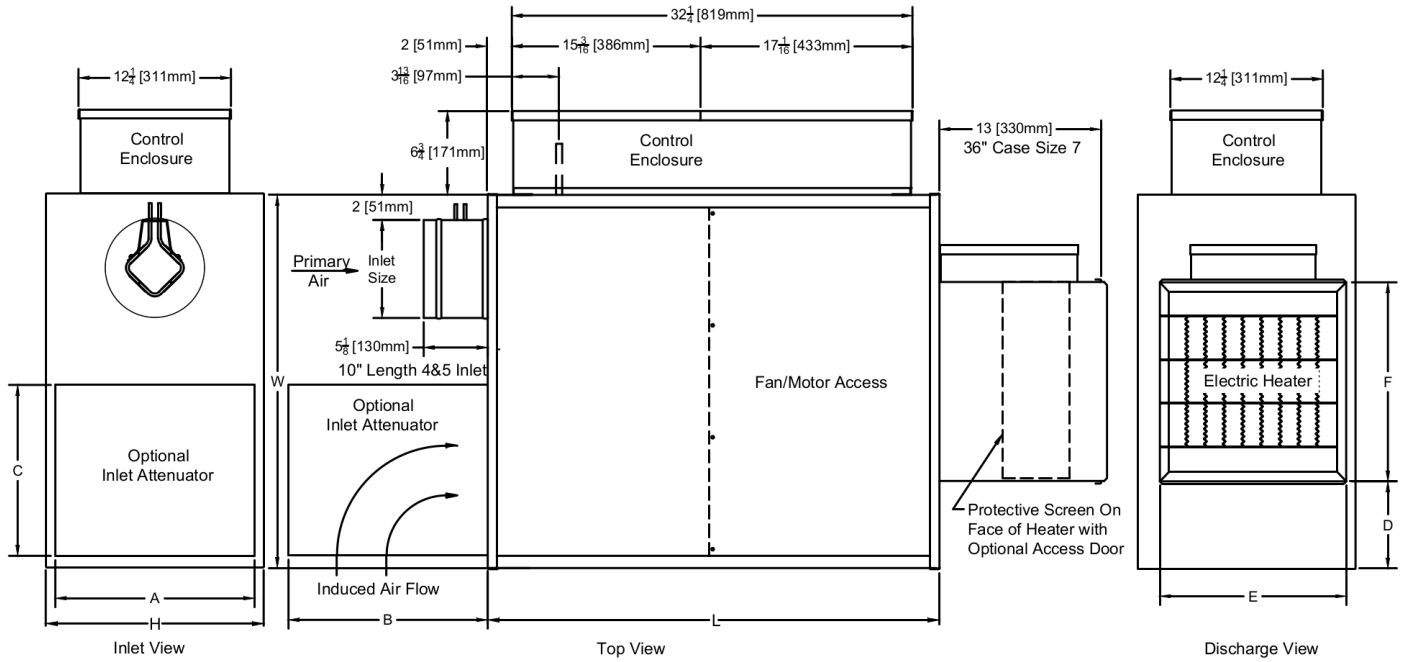

The standard location for control enclosure is Left Hand on Model FCI. Looking in the direction of airflow, the control enclosure is on the left.

Air Filter Sizes Are Equal To Induction Attenuator dimensions A & B

Field Connected Induction Duct Dimensions Should Equal A - 2" & B - 2" with a 1" Flange

Case Size	Inlet Size		Horse Power	Unit Height H	Unit Width W	Unit Length L	Induction Attenuator			Discharge		
	Standard	Optional					Height A	Width B	Length C	Loc. D	Height E	Width F
2	8 (203)	4,5,6,10,12	1/8	17 1/2 (445)	30 (762)	36 (914)	16 (406)	16 (406)	15 (381)	7 (178)	15 (381)	16 (406)
3	10 (254)	4,5,6, 8,12,14	1/8	17 1/2 (445)	36 (914)	40 (1016)	16 (406)	20 (508)	19 (483)	10 (254)	15 (381)	16 (406)
4	12 (305)	8,10,14	1/4	17 1/2 (445)	36 (914)	40 (1016)	16 (406)	20 (508)	19 (483)	8 (203)	17 1/2 (445)	20 (508)
5	14 (356)	10,12,16	1/3	20 (508)	40 (1016)	40 (1016)	20 (508)	20 (508)	19 (483)	10 (254)	17 1/2 (445)	20 (508)
6	16 (406)	10,12,14	1	20 (508)	42 (1067)	42 (1067)	20 (508)	24 (610)	21 (533)	10 (254)	17 1/2 (445)	20 (508)
7	18x16 (457x406)	12,14,16	3/4 (2)	20 (508)	46 (1168)	46 (1168)	20 (508)	24 (610)	23 (584)	4 (102)	20 (508)	38 (965)

Induction Filter and Frame Option 08 and 32

Qty: 10 Tags: CV-1N-1, CV-2N-1, CV-3N-1, CV-4N-1, CV-5N-1, CV-1S-1, CV-2S-1, CV-3S-1, CV-4S-1, CV-5S-1

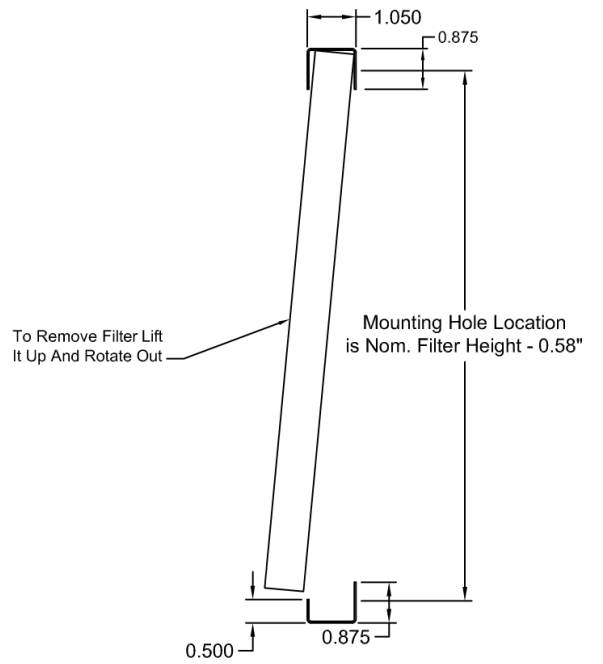
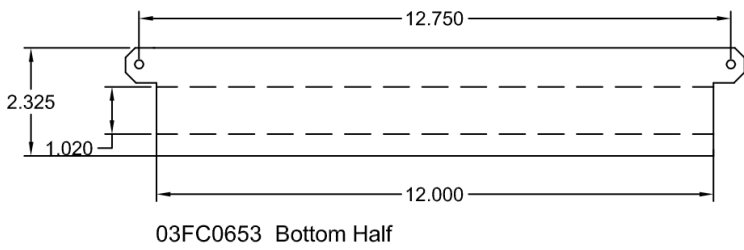
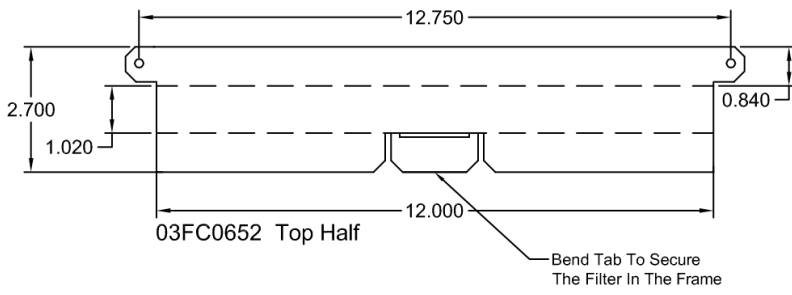

Mechanical Specifications

Tag(s): CV-1N-1,CV-1S-1,CV-2N-1,CV-2S-1,CV-3N-1,CV-3S-1,CV-4N-1,CV-4S-1,CV-5N-1,CV-5S-1

Quality, Agency, Standards

Air terminals shall be certified under the Air Conditioning, Heating and Refrigeration Institute (AHRI) Standard 880-08 Certification Program and carry the AHRI seal. All NC values shall be calculated per AHRI Standard 885-08. Units with NC values calculated per AHRI-885-90 or 98 will not be accepted. Terminal units shall be either ETL® or UL® listed as a complete assembly. Terminal electrical components, including actuators and low voltage controls shall be UL® listed. All electrical components including both line voltage and low voltage shall be mounted in a metal control enclosure. Units shall have a single point field wiring connection. Units shall be manufactured and wired per UL-1995 and in accordance with the National Electric Code.

Shipping

All terminals shall be shipped as a single unit requiring no field assembly. Accessories including hot water coils and electric heaters shall be factory mounted.

Sound Rating

The terminal manufacturer shall provide AHRI certified sound power data for radiated and discharge sound. All NC values shall be calculated per AHRI standard 885-98. Verify sound ratings for the terminal do not exceed specified value at scheduled static pressure. Sound performance shall be AHRI certified. Each individual terminal unit shall bear an AHRI label.

Fan Motor : PSC Fan Motor, Permanent Split Capacitor fan motor

Air terminals shall have a flanged connection on the discharge of the box.

Casing Material : Construction- 20 Ga construction

The terminal casing shall be constructed of minimum 20 gauge galvanized steel.

Filter Rack : Filter Rack with 1" Filter

Fan powered terminals shall have a filter rack and a 1" MERV 6-7 rated dust filter installed at the fan air intake.

Fan Access Door : Bottom Mount Fan Motor Access Door, Zip Screw

Fan powered terminals shall have a zip screw, non-recessed, bottom mount, access door for access to the blower/motor assembly.

Liner : 1" Fiberglass 1 1/2 lbs.

Air Terminals shall be internally insulated with (1") thick, 1.5 lb. /ft³, dual density fiberglass. Insulation and edges shall be coated to prevent air erosion to 6000FPM surface velocity. Insulation shall comply with UL 181 and NFPA 90A.

Handing : Handing- Control And Reheat(electric or water) Connections On Left

Air terminals shall have the controls and reheat connections located on the left side when looking in the direction of the air flow.

Airflow Sensor : Multi Quadrant Averaging Flow Sensor

The inlet flow sensor shall be a multi-point quadrant averaging flow sensor.

Outlet : Slip and Drive Connection

Air terminals shall have a slip and drive connection on the discharge.

Product Data: Parallel Fan Powered Air Terminal Unit

Qty	Description	Model Number
1	Parallel Fan Powered Air Terminal Unit	FVI C2 5 08 2.50 C EH N HS1 ZB1 C3 D1 ZA1D ZP3 Z22 Z10 32 NIA Z02 Z49 Z88 Z23 82 USR 805E

Tag(s): FPB-1S-1

Selected Options

- C2 Unit Case Size : Case Size 2
- 08 Inlet Size : Inlet Size 08 (Min: 100 /Max: 990 CFM)
- C Fan Voltage : 277 V
- EH Heating Type : Electric Heating
- N Volt Phase : 480-3-60
- HS1 Heat Steps : 1 Step
- ZB1 Transformer Fusing : Transformer with No Fusing
- C3 Disconnect Fusing : Line Disconnect Fusing
- D1 Disconnect : Door Interlocking Non-Fused Line Disconnect Switch
- ZA1D Contactors : Magnetic Contactors per Step
- ZP3 Electric Heating Enclosure : Standard Electric Heat Enclosure
- Z22 Fan Motor : PSC Fan Motor, Permanent Split Capacitor fan motor
- Z10 Casing Material : Construction- 20 Ga construction
- 32 Filter Rack : Filter Rack with 1" Filter
- NIA Attenuator : No Attenuator
- Z02 Fan Access Door : Bottom Mount Fan Motor Access Door, Zip Screw
- Z49 Liner : 1" Fiberglass 1 1/2 lbs.
- Z88 Handing : Handing- Control And Reheat(electric or water) Connections On Left
- Z23 Airflow Sensor : Multi Quadrant Averaging Flow Sensor
- 82 Outlet : Slip and Drive Connection
- USR Control Type (Select Control Sequence Second) : Controls by Other Factory Mounted
- 805E Control Sequence (Select Control Type First) : 805E - Factory Mounted Controls- Electric Heat and trans

Product Data: Parallel Fan Powered Air Terminal Unit

Qty	Description	Model Number
1	Parallel Fan Powered Air Terminal Unit	FVI C5 5 14 18.00 C EH N HS2 ZB1 C3 D1 ZA1D ZP3 Z22 Z10 32 NIA Z02 Z49 Z88 Z23 82 USR 805E

Tag(s): FPB-2N-1

Selected Options

- C5 Unit Case Size : Case Size 5
- 14 Inlet Size : Inlet Size 14 (Min: 325 /Max: 3250 CFM)
- C Fan Voltage : 277 V
- EH Heating Type : Electric Heating
- N Volt Phase : 480-3-60
- HS2 Heat Steps : 2 Steps
- ZB1 Transformer Fusing : Transformer with No Fusing
- C3 Disconnect Fusing : Line Disconnect Fusing
- D1 Disconnect : Door Interlocking Non-Fused Line Disconnect Switch
- ZA1D Contactors : Magnetic Contactors per Step
- ZP3 Electric Heating Enclosure : Standard Electric Heat Enclosure
- Z22 Fan Motor : PSC Fan Motor, Permanent Split Capacitor fan motor
- Z10 Casing Material : Construction- 20 Ga construction
- 32 Filter Rack : Filter Rack with 1" Filter
- NIA Attenuator : No Attenuator
- Z02 Fan Access Door : Bottom Mount Fan Motor Access Door, Zip Screw
- Z49 Liner : 1" Fiberglass 1 1/2 lbs.
- Z88 Handing : Handing- Control And Reheat(electric or water) Connections On Left
- Z23 Airflow Sensor : Multi Quadrant Averaging Flow Sensor
- 82 Outlet : Slip and Drive Connection
- USR Control Type (Select Control Sequence Second) : Controls by Other Factory Mounted
- 805E Control Sequence (Select Control Type First) : 805E - Factory Mounted Controls- Electric Heat and trans

Product Data: Parallel Fan Powered Air Terminal Unit

Qty	Description	Model Number
1	Parallel Fan Powered Air Terminal Unit	FVI C2 5 10 6.00 C EH N HS1 ZB1 C3 D1 ZA1D ZP3 Z22 Z10 32 NIA Z02 Z49 Z88 Z23 82 USR 805E

Tag(s): FPB-2N-2

Selected Options

- C2 Unit Case Size : Case Size 2
- 10 Inlet Size : Inlet Size 10 (Min: 165 /Max: 1640 CFM)
- C Fan Voltage : 277 V
- EH Heating Type : Electric Heating
- N Volt Phase : 480-3-60
- HS1 Heat Steps : 1 Step
- ZB1 Transformer Fusing : Transformer with No Fusing
- C3 Disconnect Fusing : Line Disconnect Fusing
- D1 Disconnect : Door Interlocking Non-Fused Line Disconnect Switch
- ZA1D Contactors : Magnetic Contactors per Step
- ZP3 Electric Heating Enclosure : Standard Electric Heat Enclosure
- Z22 Fan Motor : PSC Fan Motor, Permanent Split Capacitor fan motor
- Z10 Casing Material : Construction- 20 Ga construction
- 32 Filter Rack : Filter Rack with 1" Filter
- NIA Attenuator : No Attenuator
- Z02 Fan Access Door : Bottom Mount Fan Motor Access Door, Zip Screw
- Z49 Liner : 1" Fiberglass 1 1/2 lbs.
- Z88 Handing : Handing- Control And Reheat(electric or water) Connections On Left
- Z23 Airflow Sensor : Multi Quadrant Averaging Flow Sensor
- 82 Outlet : Slip and Drive Connection
- USR Control Type (Select Control Sequence Second) : Controls by Other Factory Mounted
- 805E Control Sequence (Select Control Type First) : 805E - Factory Mounted Controls- Electric Heat and trans

Product Data: Parallel Fan Powered Air Terminal Unit

Qty	Description	Model Number
1	Parallel Fan Powered Air Terminal Unit	FVI C5 5 12 15.00 C EH N HS2 ZB1 C3 D1 ZA1D ZP3 Z22 Z10 32 NIA Z02 Z49 Z88 Z23 82 USR 805E

Tag(s): FPB-2S-1

Selected Options

- C5 Unit Case Size : Case Size 5
- 12 Inlet Size : Inlet Size 12 (Min: 235 /Max: 2350 CFM)
- C Fan Voltage : 277 V
- EH Heating Type : Electric Heating
- N Volt Phase : 480-3-60
- HS2 Heat Steps : 2 Steps
- ZB1 Transformer Fusing : Transformer with No Fusing
- C3 Disconnect Fusing : Line Disconnect Fusing
- D1 Disconnect : Door Interlocking Non-Fused Line Disconnect Switch
- ZA1D Contactors : Magnetic Contactors per Step
- ZP3 Electric Heating Enclosure : Standard Electric Heat Enclosure
- Z22 Fan Motor : PSC Fan Motor, Permanent Split Capacitor fan motor
- Z10 Casing Material : Construction- 20 Ga construction
- 32 Filter Rack : Filter Rack with 1" Filter
- NIA Attenuator : No Attenuator
- Z02 Fan Access Door : Bottom Mount Fan Motor Access Door, Zip Screw
- Z49 Liner : 1" Fiberglass 1 1/2 lbs.
- Z88 Handing : Handing- Control And Reheat(electric or water) Connections On Left
- Z23 Airflow Sensor : Multi Quadrant Averaging Flow Sensor
- 82 Outlet : Slip and Drive Connection
- USR Control Type (Select Control Sequence Second) : Controls by Other Factory Mounted
- 805E Control Sequence (Select Control Type First) : 805E - Factory Mounted Controls- Electric Heat and trans

Product Data: Parallel Fan Powered Air Terminal Unit

Qty	Description	Model Number
1	Parallel Fan Powered Air Terminal Unit	FVI C2 5 08 4.50 C EH N HS1 ZB1 C3 D1 ZA1D ZP3 Z22 Z10 32 NIA Z02 Z49 Z88 Z23 82 USR 805E

Tag(s): FPB-2S-2

Selected Options

- C2 Unit Case Size : Case Size 2
- 08 Inlet Size : Inlet Size 08 (Min: 100 /Max: 990 CFM)
- C Fan Voltage : 277 V
- EH Heating Type : Electric Heating
- N Volt Phase : 480-3-60
- HS1 Heat Steps : 1 Step
- ZB1 Transformer Fusing : Transformer with No Fusing
- C3 Disconnect Fusing : Line Disconnect Fusing
- D1 Disconnect : Door Interlocking Non-Fused Line Disconnect Switch
- ZA1D Contactors : Magnetic Contactors per Step
- ZP3 Electric Heating Enclosure : Standard Electric Heat Enclosure
- Z22 Fan Motor : PSC Fan Motor, Permanent Split Capacitor fan motor
- Z10 Casing Material : Construction- 20 Ga construction
- 32 Filter Rack : Filter Rack with 1" Filter
- NIA Attenuator : No Attenuator
- Z02 Fan Access Door : Bottom Mount Fan Motor Access Door, Zip Screw
- Z49 Liner : 1" Fiberglass 1 1/2 lbs.
- Z88 Handing : Handing- Control And Reheat(electric or water) Connections On Left
- Z23 Airflow Sensor : Multi Quadrant Averaging Flow Sensor
- 82 Outlet : Slip and Drive Connection
- USR Control Type (Select Control Sequence Second) : Controls by Other Factory Mounted
- 805E Control Sequence (Select Control Type First) : 805E - Factory Mounted Controls- Electric Heat and trans

METALAIR

Model
FVI-C2-508

Project: IBP XVIII

Tag: **FPB-1S-1**

Altitude: 0 Feet

Qty	Mode	Case	Size			CFM			Static Pressure			Max NC Levels	
			Unit	Outlet	Max	Min	Inlet	Downstream	Min Drop	Unit Drop	Rad	Dis	
1	FVI	C2	08	16x15	990	100	1.00	0.250	0.100	0.100	25	0	



Parallel Fan Powered Air Terminal Unit

Fan Data:

Max Fan Airflow:	Min Fan Airflow:	Motor Type:	Fan HP:	External Static Pressure:	Fan Voltage:	FLA:	MCA:	MOCP:
687 CFM	360 CFM	PSC	1/6	0.25 in. H2O	277/1	1.10	5.13	15.00

Electric Heat:

Total Capacity:	Heating Airflow:	Entering Air Temp:	Leaving Air Temp:	Box Leaving Air Temp:	Volt / Phase:	Steps:
2.50 KW	400 CFM	55.00 °F	86.13 °F	86.13 °F	480-3	1 Step

Electrical Data

Min. Cir. Amps - MCA	MOCP
5.13	15.00

Design Air Flow

Max Primary:	500 CFM
Min Primary:	50 CFM
Fan Airflow:	350 CFM
Primary Heating Airflow:	50 CFM

Accessories:

Heating Coil:	EH
Inlet:	No Attenuator
Outlet:	No Attenuator

Fan Curve

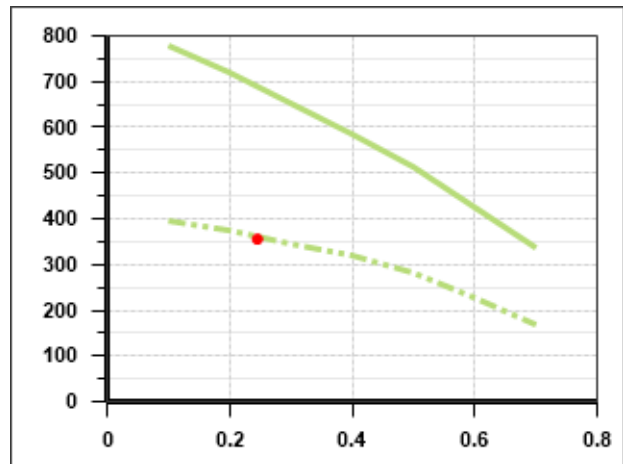

Radiated Sound Power Level (db)

Band	2	3	4	5	6	7	NC
Max Cooling	51	42	34	29	23	26	
Max Heating	60	56	46	40	36	34	
Total Attenuation	18	19	20	26	31	36	
Room Sound Level	42	37	26	14	5	0	25

Discharge Sound Power Level (db)

Band	2	3	4	5	6	7	NC
Max Cooling	61	49	42	44	36	31	
Max Heating	57	52	50	50	44	38	
Total Attenuation	27	29	40	51	53	39	
Room Sound Level	30	23	10	0	0	0	< 15

METALAIR

Model
FVI-C5-514

Project: IBP XVIII

Tag: **FPB-2N-1**

Altitude: 0 Feet

Qty	Mode	Case	Size		CFM		Static Pressure			Max NC Levels		
			Unit	Outlet	Max	Min	Inlet	Downstream	Min Drop	Unit Drop	Rad	Dis
1	FVI	C5	14	20x17 .5	3250	325	1.00	0.250	0.112	0.112	39	31



Parallel Fan Powered Air Terminal Unit

Fan Data:

Max Fan Airflow:	Min Fan Airflow:	Motor Type:	Fan HP:	External Static Pressure:	Fan Voltage:	FLA:	MCA:	MOCP:
1742 CFM	954 CFM	PSC	1/3	0.25 in. H2O	277/1	3.60	31.56	35.00

Electric Heat:

Total Capacity:	Heating Airflow:	Entering Air Temp:	Leaving Air Temp:	Box Leaving Air Temp:	Volt/Phase:	Steps:
18.00 KW	1850 CFM	55.00 °F	97.06 °F	97.06 °F	480-3	2 Steps

Electrical Data

Min. Cir. Amps - MCA	MOCP
31.56	35.00

Design Air Flow

Max Primary:	2400 CFM
Min Primary:	240 CFM
Fan Airflow:	1610 CFM
Primary Heating Airflow:	240 CFM

Accessories:

Heating Coil:	EH
Inlet:	No Attenuator
Outlet:	No Attenuator

Fan Curve

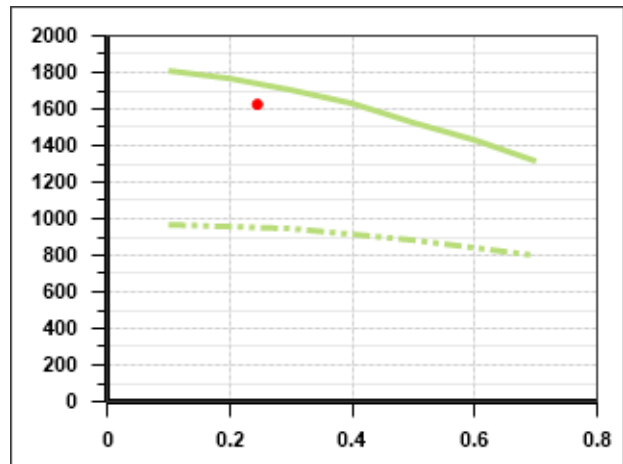

Radiated Sound Power Level (db)

Band	2	3	4	5	6	7	NC
Max Cooling	59	54	45	41	36	31	
Max Heating	72	67	64	54	53	52	
Total Attenuation	18	19	20	26	31	36	
Room Sound Level	54	48	44	28	22	16	39

Discharge Sound Power Level (db)

Band	2	3	4	5	6	7	NC
Max Cooling	66	60	53	53	49	44	
Max Heating	74	72	64	63	61	62	
Total Attenuation	29	30	41	51	52	39	
Room Sound Level	45	42	23	12	9	23	31

METALAIR

Model
FVI-C2-510

Project: IBP XVIII

Tag: **FPB-2N-2**

Altitude: 0 Feet

Qty	Mode	Case	Size		CFM		Static Pressure			Max NC Levels		
			Unit	Outlet	Max	Min	Inlet	Downstream	Min Drop	Unit Drop	Rad	Dis
1	FVI	C2	10	16x15	1640	165	1.00	0.250	0.103	0.103	29	16
							0					



Parallel Fan Powered Air Terminal Unit

Fan Data:

Max Fan Airflow:	Min Fan Airflow:	Motor Type:	Fan HP:	External Static Pressure:	Fan Voltage:	FLA:	MCA:	MOCP:
687 CFM	360 CFM	PSC	1/6	0.25 in. H2O	277/1	1.10	10.40	15.00

Electric Heat:

Total Capacity:	Heating Airflow:	Entering Air Temp:	Leaving Air Temp:	Box Leaving Air Temp:	Volt / Phase:	Steps:
6.00 KW	600 CFM	55.00 °F	97.43 °F	97.43 °F	480-3	1 Step

Electrical Data

Min. Cir. Amps - MCA	MOCP
10.40	15.00

Design Air Flow

Max Primary:	1000 CFM
Min Primary:	100 CFM
Fan Airflow:	500 CFM
Primary Heating Airflow:	100 CFM

Accessories:

Heating Coil:	EH
Inlet:	No Attenuator
Outlet:	No Attenuator

Fan Curve

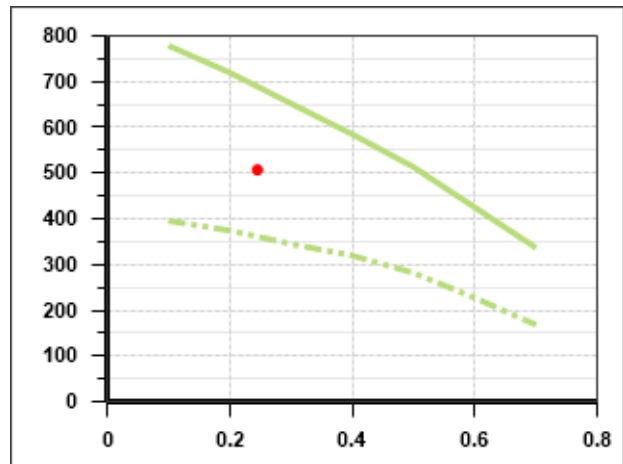

Radiated Sound Power Level (db)

Band	2	3	4	5	6	7	NC
Max Cooling	54	47	39	33	28	32	
Max Heating	64	59	49	42	38	36	
Total Attenuation	18	19	20	26	31	36	
Room Sound Level	46	40	29	16	7	0	29

Discharge Sound Power Level (db)

Band	2	3	4	5	6	7	NC
Max Cooling	64	54	48	48	44	40	
Max Heating	59	54	54	53	48	42	
Total Attenuation	27	29	40	51	53	39	
Room Sound Level	37	25	8	0	0	1	16

METALAIRE™

Model
FVI-C5-512

Project: IBP XVIII

Tag: **FPB-2S-1**

Altitude: 0 Feet

Qty	Mode	Case	Size		CFM		Static Pressure			Max NC Levels		
			Unit	Outlet	Max	Min	Inlet	Downstream	Min Drop	Unit Drop	Rad	Dis
1	FVI	C5	12	20x17 .5	2350	235	1.00 0	0.250	0.109	0.109	35	21



Parallel Fan Powered Air Terminal Unit

Fan Data:

Max Fan Airflow:	Min Fan Airflow:	Motor Type:	Fan HP:	External Static Pressure:	Fan Voltage:	FLA:	MCA:	MOCP:
1742 CFM	954 CFM	PSC	1/3	0.25 in. H2O	277/1	3.60	27.05	30.00

Electric Heat:

Total Capacity:	Heating Airflow:	Entering Air Temp:	Leaving Air Temp:	Box Leaving Air Temp:	Volt / Phase:	Steps:
15.00 KW	1540 CFM	55.00 °F	97.09 °F	97.09 °F	480-3	2 Steps

Electrical Data

Min. Cir. Amps - MCA	MOCP
27.05	30.00

Design Air Flow

Max Primary:	2000 CFM
Min Primary:	200 CFM
Fan Airflow:	1340 CFM
Primary Heating Airflow:	200 CFM

Accessories:

Heating Coil:	EH
Inlet:	No Attenuator
Outlet:	No Attenuator

Fan Curve

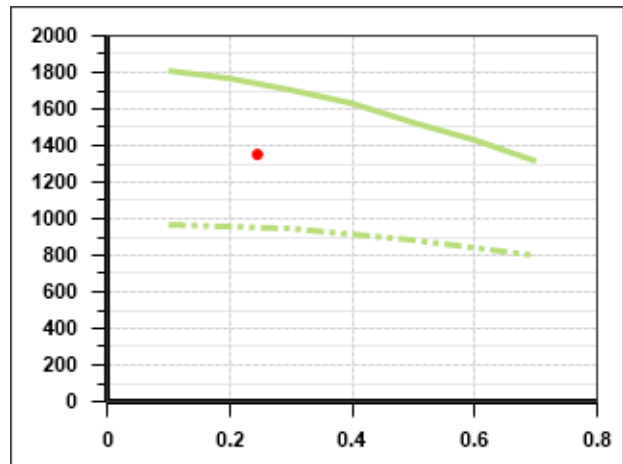

Radiated Sound Power Level (db)

Band	2	3	4	5	6	7	NC
Max Cooling	57	52	44	40	34	30	
Max Heating	69	63	60	51	50	49	
Total Attenuation	18	19	20	26	31	36	
Room Sound Level	51	44	40	25	19	13	35

Discharge Sound Power Level (db)

Band	2	3	4	5	6	7	NC
Max Cooling	64	58	52	52	46	42	
Max Heating	63	64	61	59	56	55	
Total Attenuation	29	30	41	51	52	39	
Room Sound Level	34	34	20	8	4	16	21

METALAIRE™

**Model
FVI-C2-508**

Project: IBP XVIII

Tag: **FPB-2S-2**

Altitude: 0 Feet

Qty	Mode	Case	Size			CFM			Static Pressure			Max NC Levels	
			Unit	Outlet	Max	Min	Inlet	Downstream	Min Drop	Unit Drop	Rad	Dis	
1	FVI	C2	08	16x15	990	100	1.00	0.250	0.105	0.105	26	0	



Parallel Fan Powered Air Terminal Unit

Fan Data:

Max Fan Airflow:	Min Fan Airflow:	Motor Type:	Fan HP:	External Static Pressure:	Fan Voltage:	FLA:	MCA:	MOCP:
687 CFM	360 CFM	PSC	1/6	0.25 in. H2O	277/1	1.10	8.14	15.00

Electric Heat:

Total Capacity:	Heating Airflow:	Entering Air Temp:	Leaving Air Temp:	Box Leaving Air Temp:	Volt / Phase:	Steps:
4.50 KW	460 CFM	55.00 °F	97.22 °F	97.22 °F	480-3	1 Step

Electrical Data

Min. Cir. Amps - MCA	MOCP
8.14	15.00

Design Air Flow

Max Primary:	600 CFM
Min Primary:	60 CFM
Fan Airflow:	400 CFM
Primary Heating Airflow:	60 CFM

Accessories:

Heating Coil:	EH
Inlet:	No Attenuator
Outlet:	No Attenuator

Fan Curve

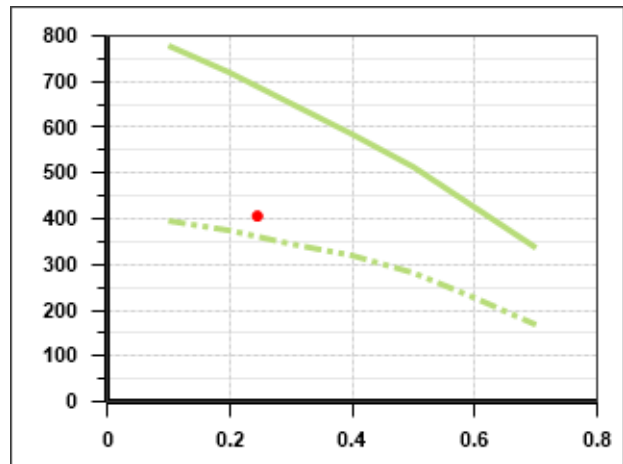

Radiated Sound Power Level (db)

Band	2	3	4	5	6	7	NC
Max Cooling	52	43	35	30	24	27	
Max Heating	62	57	47	41	37	35	
Total Attenuation	18	19	20	26	31	36	
Room Sound Level	44	38	27	15	6	0	26

Discharge Sound Power Level (db)

Band	2	3	4	5	6	7	NC
Max Cooling	62	50	44	45	38	33	
Max Heating	57	52	52	51	46	39	
Total Attenuation	27	29	40	51	53	39	
Room Sound Level	30	23	12	0	0	0	< 15

FVI500-004 - FVI with EH

Qty: 5 Tags: FPB-1S-1, FPB-2N-1, FPB-2N-2, FPB-2S-1, FPB-2S-2

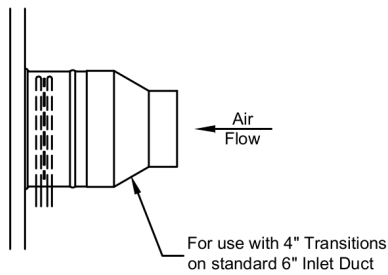
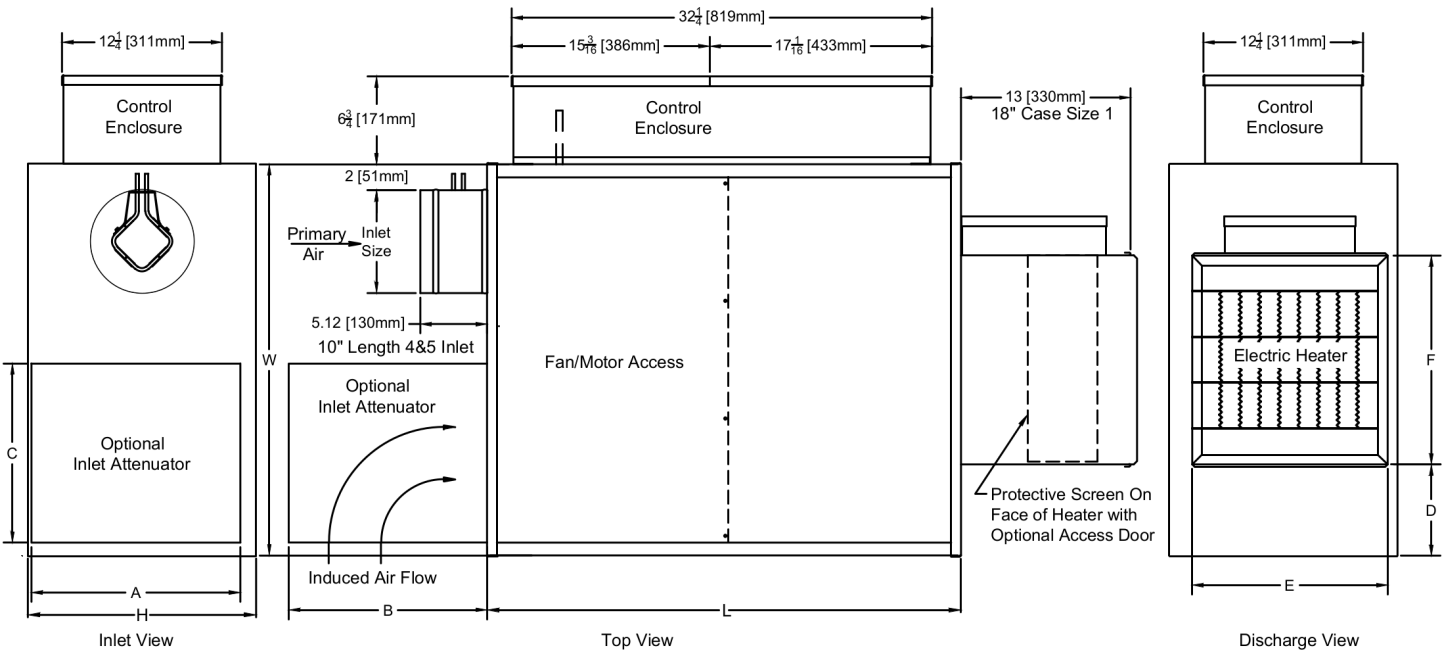

The standard location for control enclosure is Left Hand on Model FVI. Looking in the direction of airflow, the control enclosure is on the left.

Air Filter Sizes Are Equal To Induction Attenuator dimensions A & B

Field Connected Induction Duct Dimensions Should Equal A - 2" & B - 2" with a 1" Flange

Case Size	Inlet Size		Horse Power	Unit Height H	Unit Width W	Unit Length L	Optional Induction Attenuator			Discharge		
	Standard	Optional					Height A	Width B	Length C	Loc. D	Height E	Width F
1	6 (152)	4, 5, 8, 10	1/8	17 1/2 (445)	30 (762)	36 (914)	16 (406)	16 (406)	15 (381)	7 (178)	15 (381)	16 (406)
2	8 (203)	4,5,6,10	1/6	17 1/2 (445)	30 (762)	36 (914)	16 (406)	16 (406)	15 (381)	7 (178)	15 (381)	16 (406)
3	10 (254)	4,5,6,8,12,14	1/4	17 1/2 (445)	36 (914)	40 (1016)	16 (406)	20 (508)	19 (483)	10 (254)	15 (381)	16 (406)
4	12 (305)	8,10,12,14	1/4	17 1/2 (445)	36 (914)	40 (1016)	16 (406)	20 (508)	19 (483)	8 (203)	17 1/2 (445)	20 (508)
5	14 (356)	10,12,16	1/3	20 (508)	40 (1016)	40 (1016)	20 (508)	20 (508)	19 (483)	10 (254)	17 1/2 (445)	20 (508)
6	16 (406)	10,12,14	1/2	20 (508)	42 (1067)	42 (1067)	20 (508)	24 (610)	21 (533)	10 (254)	17 1/2 (445)	20 (508)
7	16 (406)	12,14	1	20 (508)	42 (1067)	42 (1067)	20 (508)	24 (610)	23 (584)	6 (152)	20 (508)	30 (762)

Induction Filter and Frame Option 08 and 32

Qty: 5 Tags: FPB-1S-1, FPB-2N-1, FPB-2N-2, FPB-2S-1, FPB-2S-2

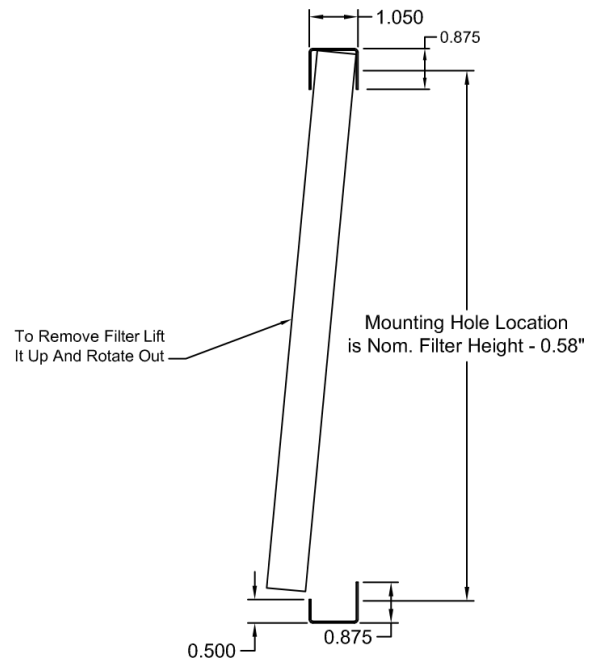
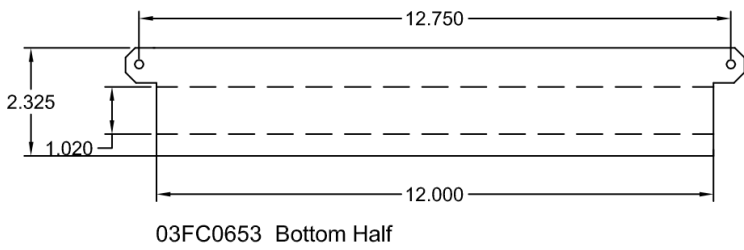
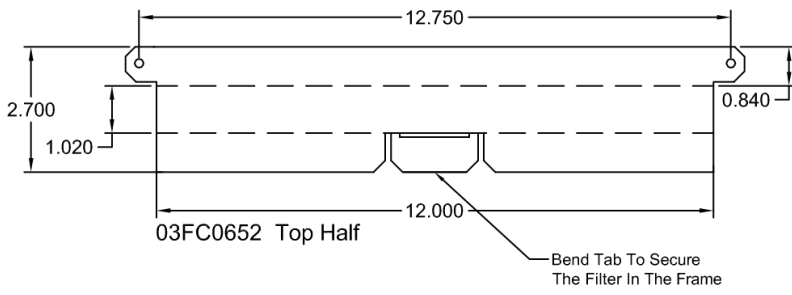

Mechanical Specifications

Tag(s): FPB-1S-1,FPB-2N-1,FPB-2N-2,FPB-2S-1,FPB-2S-2

Quality, Agency, Standards

Air terminals shall be certified under the Air Conditioning, Heating and Refrigeration Institute (AHRI) Standard 880-08 Certification Program and carry the AHRI seal. All NC values shall be calculated per AHRI Standard 885-08. Units with NC values calculated per AHRI-885-90 or 98 will not be accepted. Terminal units shall be either ETL® or UL® listed as a complete assembly. Terminal electrical components, including actuators and low voltage controls shall be UL® listed. All electrical components including both line voltage and low voltage shall be mounted in a metal control enclosure. Units shall have a single point field wiring connection. Units shall be manufactured and wired per UL-1995 and in accordance with the National Electric Code.

Shipping

All terminals shall be shipped as a single unit requiring no field assembly. Accessories including hot water coils and electric heaters shall be factory mounted.

Sound Rating

The terminal manufacturer shall provide AHRI certified sound power data for radiated and discharge sound. All NC values shall be calculated per AHRI standard 885-98. Verify sound ratings for the terminal do not exceed specified value at scheduled static pressure. Sound performance shall be AHRI certified. Each individual terminal unit shall bear an AHRI label.

Fan Motor : PSC Fan Motor, Permanent Split Capacitor fan motor

Air terminals shall have a flanged connection on the discharge of the box.

Casing Material : Construction- 20 Ga construction

The terminal casing shall be constructed of minimum 20 gauge galvanized steel.

Filter Rack : Filter Rack with 1" Filter

Fan powered terminals shall have a filter rack and a 1" MERV 6-7 rated dust filter installed at the fan air intake.

Fan Access Door : Bottom Mount Fan Motor Access Door, Zip Screw

Fan powered terminals shall have a zip screw, non-recessed, bottom mount, access door for access to the blower/motor assembly.

Liner : 1" Fiberglass 1 1/2 lbs.

Air Terminals shall be internally insulated with (1") thick, 1.5 lb. /ft³, dual density fiberglass. Insulation and edges shall be coated to prevent air erosion to 6000FPM surface velocity. Insulation shall comply with UL 181 and NFPA 90A.

Handing : Handing- Control And Reheat(electric or water) Connections On Left

Air terminals shall have the controls and reheat connections located on the left side when looking in the direction of the air flow.

Airflow Sensor : Multi Quadrant Averaging Flow Sensor

The inlet flow sensor shall be a multi-point quadrant averaging flow sensor.

Outlet : Slip and Drive Connection

Air terminals shall have a slip and drive connection on the discharge.