

FOR QUESTIONS, CALL THE
 Highwoods Group
 REGION 40
 PHONE: (919) 875-0420
 EMAIL: reg40@captiveaire.com

EXHAUST FAN INFORMATION - JOB#5909089

FAN UNIT NO	TAG	QTY	FAN UNIT MODEL #	MANUFACTURER	CFM	ESP	RPM	MOTOR ENCL	HP	BHP	PHASE	VOLT	FLA	WEIGHT (LBS)	SDNES
1	EF-2	1	DR12HFA	CAPTIVEAIRE	150	0.600	1282	TEAD-ECM	0.250	0.0930	1	115	2.9	50	6.1

FAN OPTIONS

FAN UNIT NO	TAG	QTY	DESCRIPTION
1	EF-2	1	ECM WIRING PACKAGE - EXHAUST - MANUAL DR 0-10VDC REFERENCE SPEED CTRL -MSC- (TELCD), CCW ROTATION
		1	1 12-BDD DAMPER
		1	2 YEAR PARTS WARRANTY

FAN ACCESSORIES

FAN UNIT NO	TAG	EXHAUST				SUPPLY		
		GREASE CUP	GRAVITY DAMPER	WALL MOUNT	SIDE DISCHARGE	GRAVITY DAMPER	MOTORIZED DAMPER	WALL MOUNT
1	EF-2		YES					

CURB ASSEMBLIES

NO	DN FAN	TAG	WEIGHT	ITEM	SIZE
1	# 1	EF-2	31 LBS	CURB	17.500"W X 17.500"L X 26.000"H ALONG LENGTH, RIGHT.

FAN #1 DR12HFA - EXHAUST FAN (EF-2)

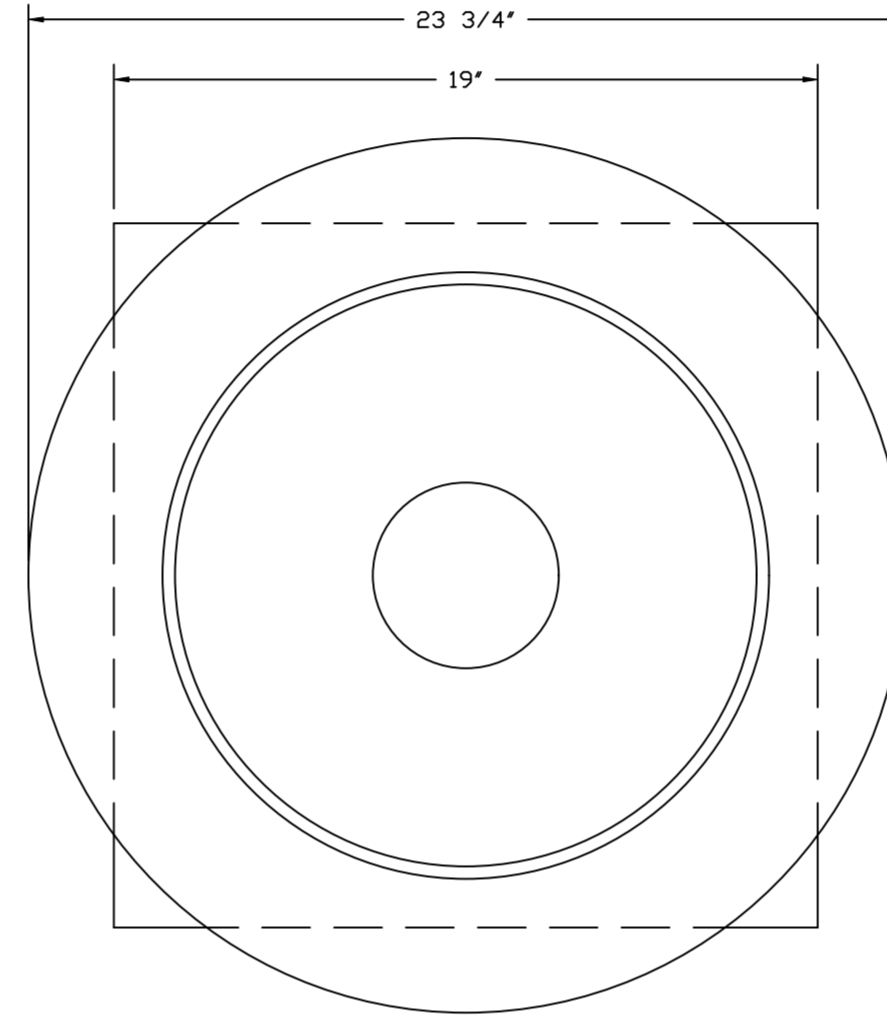
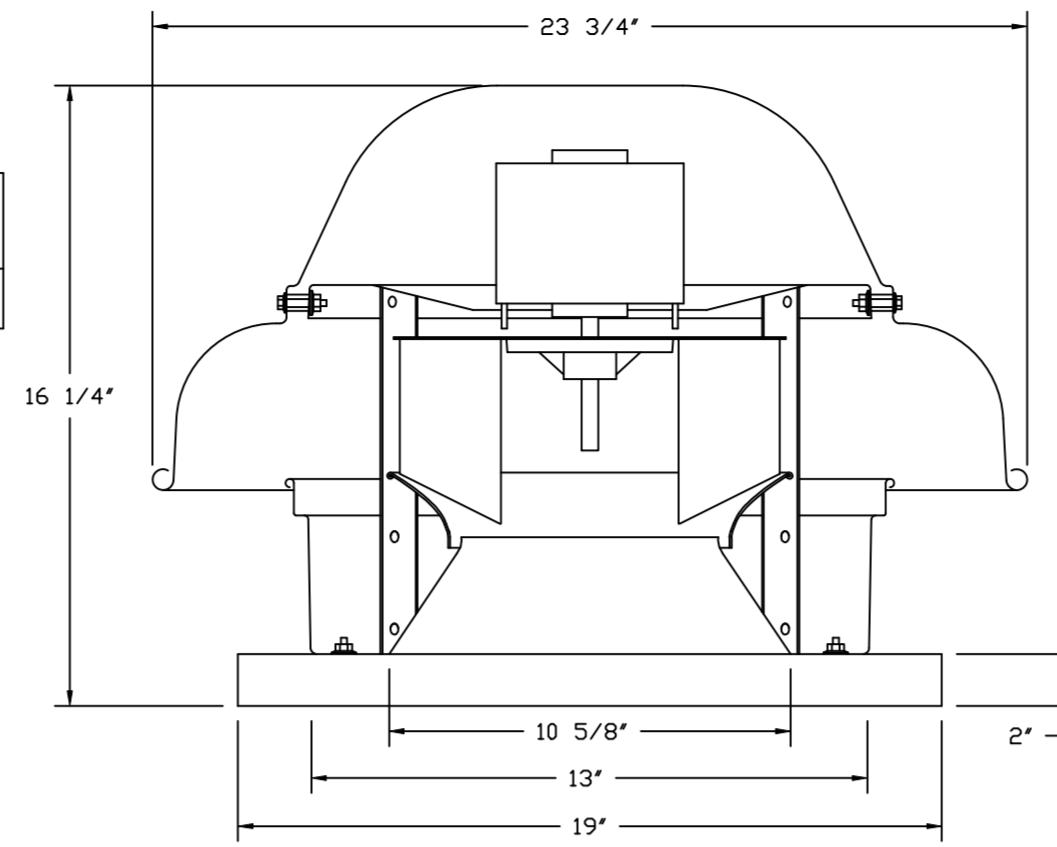

TOP VIEW

FEATURES:

- DIRECT DRIVE CONSTRUCTION (NO BELTS/PULLEYS).
- ROOF MOUNTED FANS.
- UL705.
- SAFETY DISCONNECT.
- STANDARD BIRD SCREEN.
- SPEED CONTROL.
- THERMAL OVERLOAD PROTECTION (SINGLE PHASE).

OPTIONS

- ECM WIRING PACKAGE - EXHAUST - MANUAL DR 0-10VDC REFERENCE SPEED CONTROL -MSC- (TELCD), CCW ROTATION.
- 1 12-BDD DAMPER.
- 2 YEAR PARTS WARRANTY.

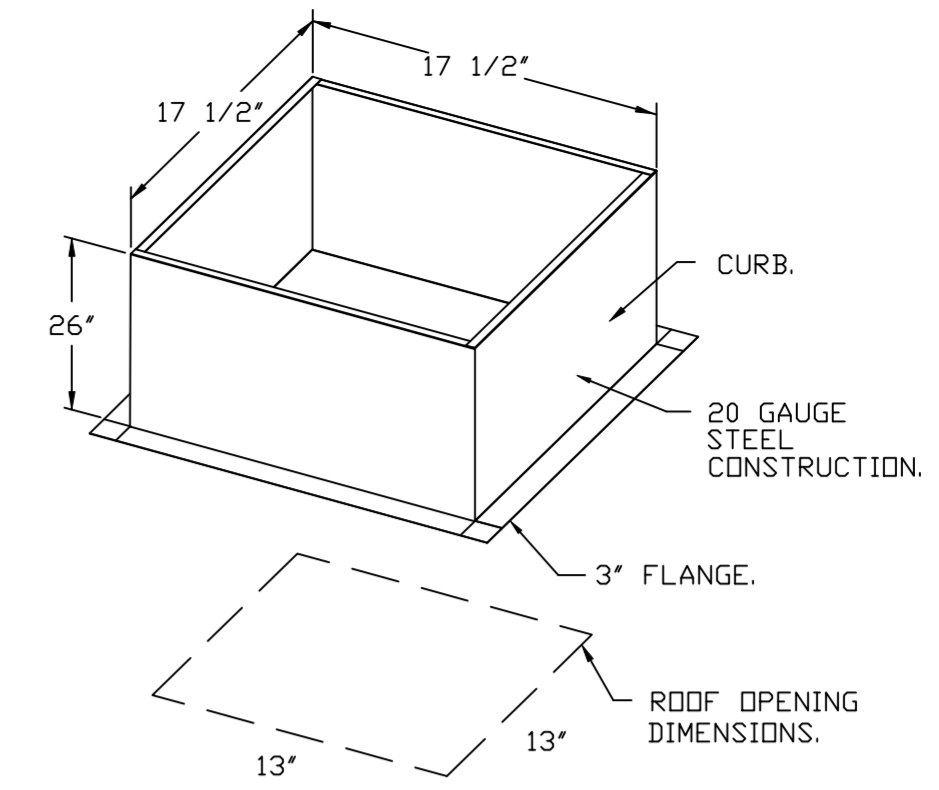

BACKDRAFT DAMPER INSTALLATION

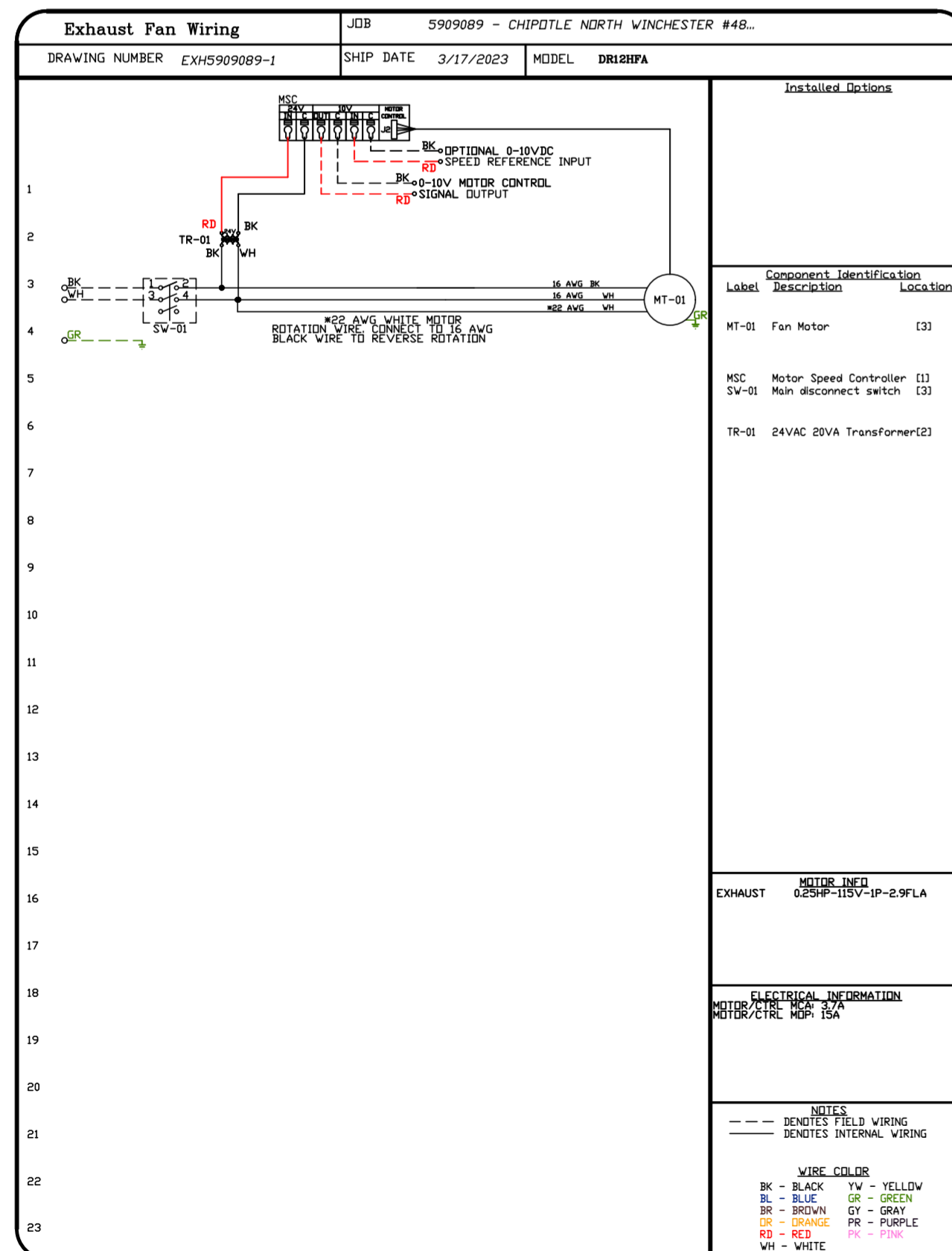
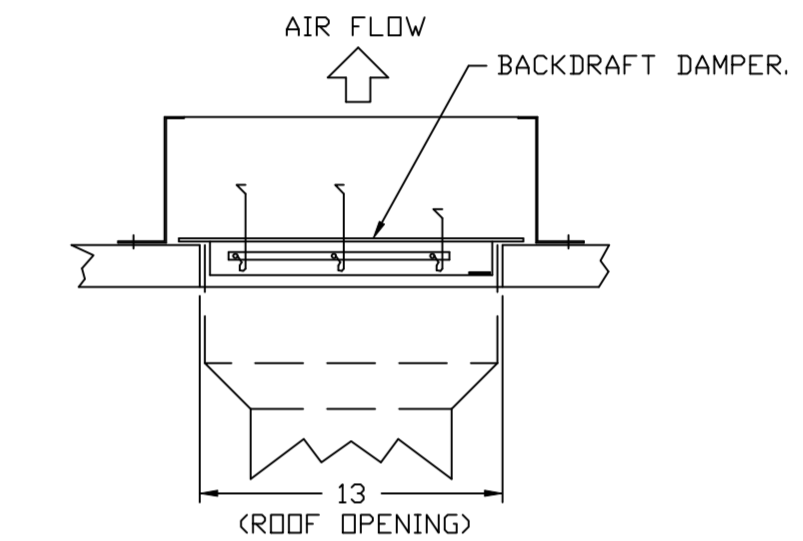

REVISIONS

DESCRIPTION	DATE:

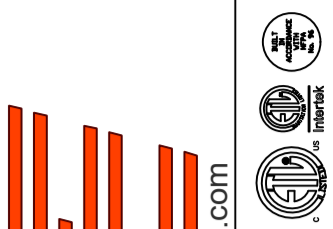

www.captiveaire.com

Highwoods Group

4641 Paragon Park Rd., Raleigh, NC 27616 PHONE: (919) 875-0420 FAX: (919) 875-0577 EMAIL: reg40@captiveaire.com

CHIPOTLE NORTH WINCHESTER #4823
 WINCHESTER, VA, 22603

DATE: 3/17/2023

DWG.#: 5909089

DRAWN BY: JMB-40

SCALE: 3/4" = 1'-0"

MASTER DRAWING

SHEET NO.