



Lennox National Accounts Project Submittal

Project Name: Barnes & Noble #2237 - Saint Peters, MO
Project Number: 400803
Project Altitude: 500
Project Location:
Saint Peters, Missouri US

Date: 2/9/2023
Quote: 303199
Roof Top Units: 8
Split Systems: 0

Customer: Barnes & Noble Inc
National Account: Barnes & Noble Inc

Table of Contents

Tag	Qty	Model	Description
<u>RTU 1,3</u>	2	LGT210H4M	LGT210H4M-G 17.5T CONF E=12.0
<u>RTU 2,4</u>	2	LGT210H4M	LGT210H4M-G 17.5T CONF E=12.0
<u>RTU 5</u>	1	LGT048H4E	LGT048H4E-G 4T CONF S=17
<u>RTU 6</u>	1	LGT060H4E	LGT060H4E-G 5T CONF S=17
<u>RTU 7</u>	1	LGT036H4E	LGT036H4E-G 3T CONF S=17.0
<u>RTU 8</u>	1	LGT120H4E	LGT120H4E-G 10T CONF E=12.1
<u>Miscellaneous Items</u>			

Revit® Building Information Modeling (BIM) - [Click here](#)

AutoCAD® Templates - [Click here](#)



Lennox National Accounts Project Submittal

Tag: RTU 1,3
Model: LGT210H4M - LGT210H4M-G 17.5T CONF E=12.0

UNIT OVERVIEW

Voltage	IEER EER	MCA/MOCP (amp)	Gross Cooling Ttl/Sens (MBH)	Net Cooling Ttl/Sens (MBH)	Supply Air Flow (cfm)	ESP/TSP (in.WC)	EAT DB/WB (°F)	LAT DB/WB (°F)
460V 3Ph 60Hz	16 12	42 / 45	218.8 / 166.3	208.4 / 155.9	7,000	0.50 / 0.87	80.0 / 67.0	57.0 / 56.6

COOLING

Cooling Performance			Temperatures (DB/WB °F)		
Gross Cooling (Ttl/Sens)	218.8 / 166.3 MBH		Ambient	95.0	
Net Cooling (Ttl/Sens)	208.4 / 155.9 MBH		Entering	80.0	67.0
Coil Moisture Removal	49.49 lb/hr		Leaving - (Coil)	57.0	
System Moisture Removal	49.49 lb/hr		Leaving - (Unit)	58.5	

ARI Performance		Compressors		Refrigerant		Condensate Drain	
ARI Cooling	206.0 / 200.0 MBH	Cooling Stages	4.0	Type	R-410A	Qty	1
ARI Power	16,600 W	Compressor Qty	4	Charge	26 LBS. 1 OZ.	Size	1 in.
		Compressor RLA	20.8 amp			Pipe Thread	FPT

HEATING

Heating Performance		Temperatures (DB/WB °F)		Specifications	
Output (High/Low)	389.0 / 389.0 MBH	Leaving	51.5	Heat Stages	2
Input (High/Low)	480.0 / 156.0 MBH			Thermal Efficiency	81.0%
Heat Rise	51.5 °F			Gas Line Size	1 in.
				Gas Pressure	7 in.WC

VENTILATION

Air Flow (cfm)		Supply Fan		Air Resistance (in.WC)	
Supply	7,000	Nominal Power	5.00 hp	Total	0.87
		Required Power	3.59 hp	Ext Supply	0.50
		Drive Type	MSAV Belt Drive		
		RPM Range	685 - 856 rpm		
		Required RPM	848 rpm		

AIR RESISTANCE - OPTIONS/ACCESSORIES (in.WC)

Wet Coil	Humiditrol	Heat	Economizer	Filters	Diffuser	Exhaust	ERW
0.10		0.19	0.04	0.04			

ELECTRICAL

Voltage	460V 3Ph / 60Hz	Compressor RLA	20.8 amp
MCA	42 amp	Cooling FLA Total	33.6 amp
MOCP	45 amp	Condenser FLA	5.2 amp
Condenser Power	1500 W	Supply Fan FLA	7.6 amp
Oper Range-Nom Volt	+/- 10%		

ADDITIONAL DATA

Cabinet	132.62 in. x 91.12 in. x 54.25 in.	Total Weight	2,862 lb
Downflow Supply	20.0 in. x 28.0 in.	Base Unit Net Weight	2,569 lb
Downflow Return	15.0 in. x 60.5 in.	OAS/Econ Weight	167 lb
Filters	(6) 24.0 in. x 24.0 in. x 2.0 in.	Gas Heat Weight	64 lb
Sound Rating	94 dBA		



Lennox National Accounts Project Submittal

Tag: RTU 1,3

Factory Installed Options

- High Performance Economizer Upgrade Factory Installed
- Single Enthalpy High Performance Economizer
- Belt Drive
- Unit Orientation Downflow
- Supply Fan: Multi-Stage Air Volume Belt
- 440V/460V/480V 3Phase
- 80Amp Disconnect Factory Installed
- Built-in BACnet IP and MS/TP (standard)
- Supply Motor - 5.0 Hp Std- w/ MSAV
- Supply Drive Kit 3 (685-856 RPM)
- Std Static Power Exhaust Fan
- 480K A.S. (Dual Stage)
- Combination Coil/Hail Guards Factory Installed
- Hinged Access Doors Factory Installed
- 15A GFCI Factory Installed/Field Wired
- Supply Air Smoke Detector Factory Installed
- Return Air Smoke Detector Factory Installed
- Environ Condenser Coil System Factory Installed
- 2" MERV8 - Filter Factory installed

Field Installed Accessories

Catalog Number	Qty	Description
54W78	2	Downflow Barometric Relief Dampers Field Installed
87N53	2	CO2 Sensors - Wall-mount, off-white plastic cover, no display Field Installed
Y3027	2	BE RTS2-AOS Multi Signal Accessory

Product Features

Cabinet

- Hinged Access Panels
- Durable Outdoor Enamel Paint Finish
- Totally Enclosed Outdoor Fan Motor
- PVC Coated Fan Guard
- Corrosion-Resistant Drain Pan
- Isolated Compressor Compartment

Cooling System

- Scroll Compressor
- Expansion Valves
- High Capacity Driers
- Crankcase Heater
- System can operate from 0°F to 125°F without any additional controls
- Pre-charged Refrigeration System
- Internal Pressure Relief Valve
- Building Automation Integrated Control - Up to 4 Stages of Cooling

Heating System

- Redundant Automatic Gas Valve with Manual Shut-off
- Electronic Flame Sensor
- Direct Spark Ignition
- Aluminized Steel Inshot Burners
- If configured for room sensor control, additional staging may be possible. Refer to performance tables within the EHB

Control System

- Fan and Limit Controls
- Overload Protection
- Microprocessor Controls – Lennox® CORE Control System
- Auto reset high & low pressure switch with strike 3 lockout feature in Lennox® CORE Control System
- Limited warranty on Lennox® CORE Control System of 3 years
- Built-in BACnet IP & MS/TP
- Phase/Voltage Detection

Compliance



Lennox National Accounts Project Submittal

All models are ASHRAE 90.1-2019 energy efficiency compliant and meet or exceed requirements of Section 6.8
All models meet DOE 2018 and 2023 energy efficiency standards
Model meets California Code of Regulations, Title 24 and ASHRAE 90.1-2016 Section 6.4.3.10 requirements for staged airflow
Model meets HCAI (formerly OSHPD) OSP and Special Seismic Certification (Number: OSP-0596) and meet 2018 International Building Code (IBC), 2019
California Building Code (CBC) ASCE 7, and ICC-ES AC156
ISO 9001 Registered Manufacturing Quality System

Warranty

Limited warranty on aluminized heat exchanger of 10 years
Limited warranty on compressor of 5 years
Limited warranty on Environ Coil System of 3 years
Limited warranty on High Performance Economizer of 5 years
Limited warranty on all other components of 1 year
See Limited Warranty Certificate included with unit for details



Lennox National Accounts Project Submittal

Corner Weights (lb)								Center of Gravity (in.)			
AA		BB		CC		DD		EE		FF	
Base	Max	Base	Max	Base	Max	Base	Max	Base	Max	Base	Max
512	624	620	709	787	809	650	712	58.99	57.31	40.16	42.54

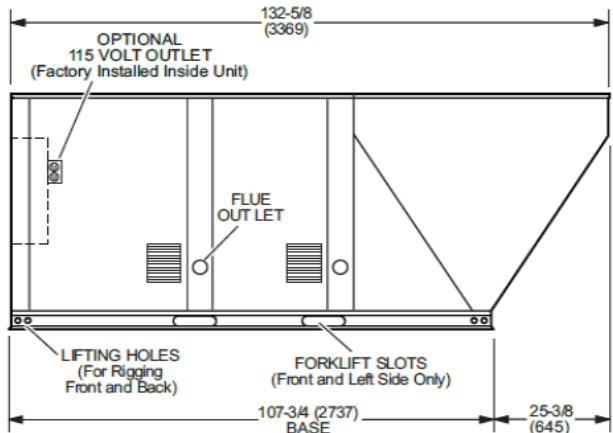
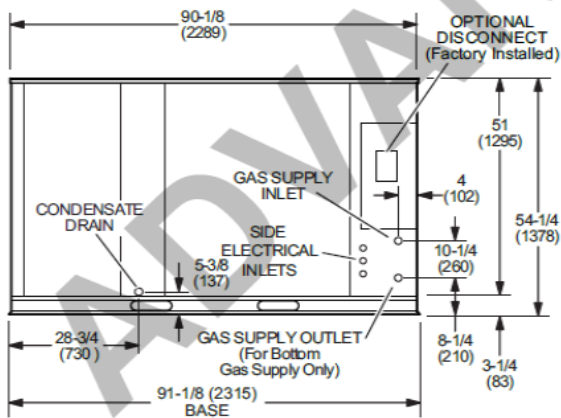
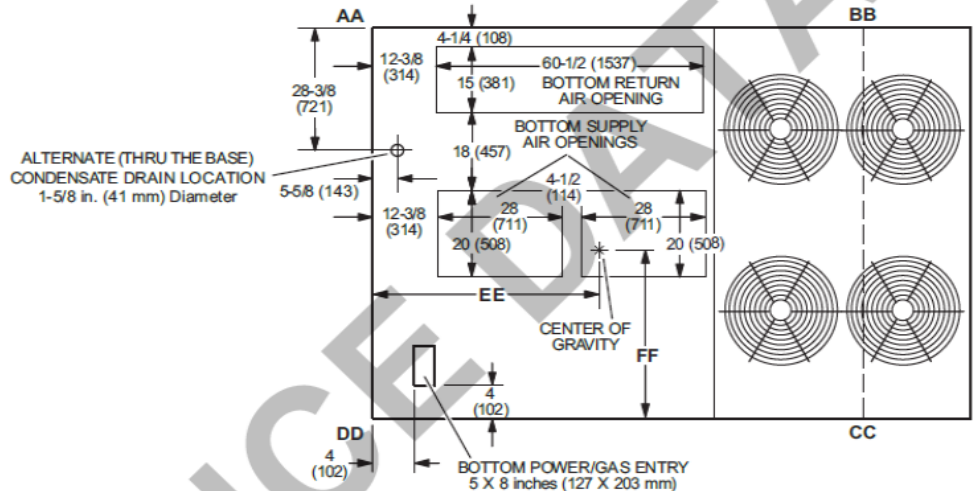



Lennox National Accounts Project Submittal

OUTDOOR AIR HOOD DETAIL

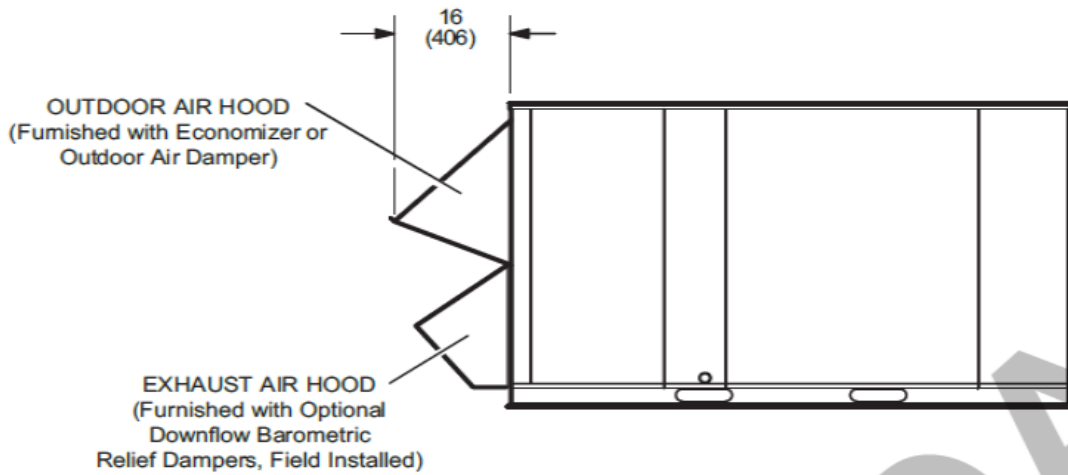

OPTIONAL HORIZONTAL BAROMETRIC RELIEF DAMPERS WITH HOOD (Field installed in horizontal return air duct adjacent to unit)

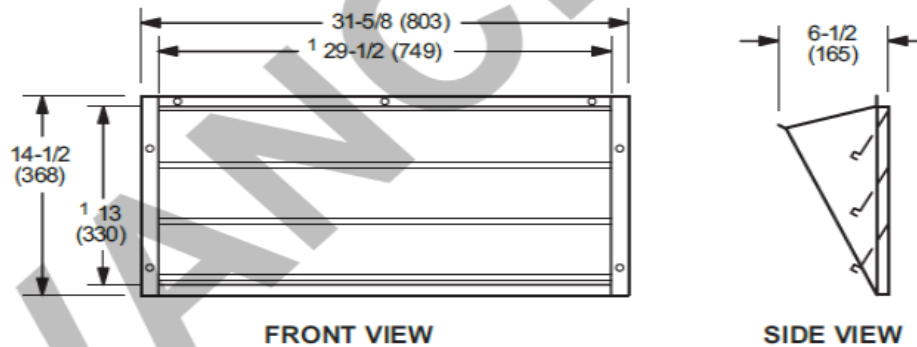

NOTE - Two furnished per order no.
¹ NOTE - Opening size required in return air duct.



Lennox National Accounts Project Submittal

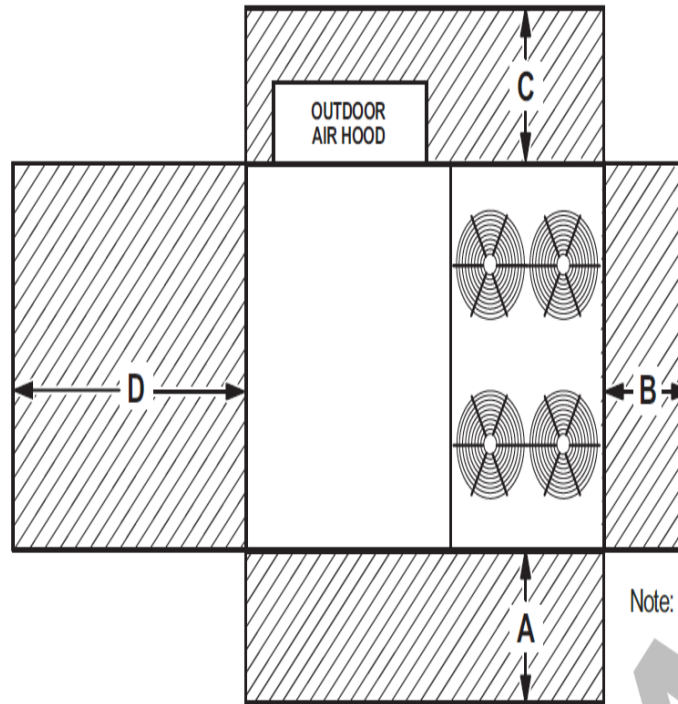

Note: Models with four outdoor fans shown.
Dimension clearances are for all sizes.

¹ Unit Clearance	A		B		C		D		Top Clearance
	in.	mm	in.	mm	in.	mm	in.	mm	
Service Clearance	60	1524	36	914	36	934	66	1676	Unobstructed
Clearance to Combustibles	36	914	1	25	1	25	1	25	
Minimum Operation Clearance	45	1143	36	914	36	914	41	1041	

NOTE - Entire perimeter of unit base requires support when elevated above the mounting surface.

¹ Service Clearance - Required for removal of serviceable parts.

Clearance to Combustibles - Required clearance to combustible material.



Lennox National Accounts Project Submittal

Tag: RTU 2,4
Model: LGT210H4M - LGT210H4M-G 17.5T CONF E=12.0

UNIT OVERVIEW

Voltage	IEER EER	MCA/MOCP (amp)	Gross Cooling Ttl/Sens (MBH)	Net Cooling Ttl/Sens (MBH)	Supply Air Flow (cfm)	ESP/TSP (in.WC)	EAT DB/WB (°F)	LAT DB/WB (°F)
460V 3Ph 60Hz	16 12	42 / 45	218.8 / 166.3	208.1 / 155.5	7,000	0.50 / 0.91	80.0 / 67.0	57.0 / 56.6

COOLING

Cooling Performance		Temperatures (DB/WB °F)		
Gross Cooling (Ttl/Sens)	218.8 / 166.3 MBH	Ambient	95.0	
Net Cooling (Ttl/Sens)	208.1 / 155.5 MBH	Entering	80.0	67.0
Coil Moisture Removal	49.49 lb/hr	Leaving - (Coil)	57.0	56.6
System Moisture Removal	49.49 lb/hr	Leaving - (Unit)	58.5	57.2

ARI Performance		Compressors		Refrigerant		Condensate Drain	
ARI Cooling	206.0 / 200.0 MBH	Cooling Stages	4.0	Type	R-410A	Qty	1
ARI Power	16,600 W	Compressor Qty	4	Charge		Size	1 in.
		Compressor RLA	20.8 amp			Pipe Thread	FPT

HUMIDITROL - HOT GAS REHEAT

Humiditrol Dehumidification Performance		Temperatures (DB/WB °F)		
Gross Cooling - Stage 1(Ttl/Sens)	39.7 / 30.2 MBH	Ambient	95.0	
Gross Cooling - Stage 2 (Ttl/Sens)	124.1 / 64.5 MBH	Entering	80.0	67.0
Moisture Removal - Stage 1	9.0 lb/hr	Leaving - (Stage 1)	74.5	64.1
Moisture Removal - Stage 2	56.2 lb/hr	Leaving - (Stage 2)	67.2	60.9

HEATING

Heating Performance		Temperatures (DB/WB °F)		Specifications		
Output (High/Low)	389.0 / 389.0 MBH	Leaving	51.5		Heat Stages	2
Input (High/Low)	480.0 / 156.0 MBH				Thermal Efficiency	81.0%
Heat Rise	51.5 °F				Gas Line Size	1 in.
					Gas Pressure	7 in.WC

VENTILATION

Air Flow (cfm)		Supply Fan			Air Resistance (in.WC)	
Supply	7,000	Nominal Power	5.00 hp		Total	0.91
		Required Power	3.70 hp		Ext Supply	0.50
		Drive Type	MSAV Belt Drive			
		RPM Range	850 - 1,045 rpm			
		Required RPM	861 rpm			

AIR RESISTANCE - OPTIONS/ACCESSORIES (in.WC)

Wet Coil	Humiditrol	Heat	Economizer	Filters	Diffuser	Exhaust	ERW
0.10	0.04	0.19	0.04	0.04			

ELECTRICAL

Voltage	460V 3Ph / 60Hz	Compressor RLA	20.8 amp
MCA	42 amp	Cooling FLA Total	33.6 amp
MOCP	45 amp	Condenser FLA	5.2 amp
Condenser Power	1500 W	Supply Fan FLA	7.6 amp
Oper Range-Nom Volt	+/- 10%		

ADDITIONAL DATA

Cabinet	132.62 in. x 91.12 in. x 54.25 in.	Total Weight	2,912 lb
Downflow Supply	20.0 in. x 28.0 in.	Base Unit Net Weight	2,569 lb
Downflow Return	15.0 in. x 60.5 in.	OAS/Econ Weight	167 lb
Filters	(6) 24.0 in. x 24.0 in. x 2.0 in.	Humiditrol Weight	50 lb
Sound Rating	94 dBA	Gas Heat Weight	64 lb



Lennox National Accounts Project Submittal

Tag: RTU 2,4

Factory Installed Options

High Performance Economizer Upgrade Factory Installed
 Single Enthalpy High Performance Economizer
 Belt Drive
 Unit Orientation Downflow
 Supply Fan: Multi-Stage Air Volume Belt
 440V/460V/480V 3Phase
 80Amp Disconnect Factory Installed
 Built-in BACnet IP and MS/TP (standard)
 Supply Motor - 5.0 Hp Std- w/ MSAV
 Supply Drive Kit 4 (850-1045 RPM)
 Std Static Power Exhaust Fan
 480K A.S. (Dual Stage)
 Combination Coil/Hail Guards Factory Installed
 Hinged Access Doors Factory Installed
 15A GFCI Factory Installed/Field Wired
 Supply Air Smoke Detector Factory Installed
 Return Air Smoke Detector Factory Installed
 Environ Condenser Coil System Factory Installed
 Humiditrol Factory Installed
 2" MERV8 - Filter Factory installed

Field Installed Accessories

Catalog Number	Qty	Description
54W78	2	Downflow Barometric Relief Dampers Field Installed
17M50	2	Humidity Sensor Kit Field Installed
87N53	2	CO2 Sensors - Wall-mount, off-white plastic cover, no display Field Installed
Y3027	2	BE RTS2-AOS Multi Signal Accessory

Product Features

Cabinet

Hinged Access Panels
 Durable Outdoor Enamel Paint Finish
 Totally Enclosed Outdoor Fan Motor
 PVC Coated Fan Guard
 Corrosion-Resistant Drain Pan
 Isolated Compressor Compartment

Cooling System

Scroll Compressor
 Expansion Valves
 High Capacity Driers
 Crankcase Heater
 System can operate from 0°F to 125°F without any additional controls
 Pre-charged Refrigeration System
 Internal Pressure Relief Valve
 Building Automation Integrated Control - Up to 4 Stages of Cooling
 Humiditrol - Hot Gas Reheat Dehumidification System

Heating System

Redundant Automatic Gas Valve with Manual Shut-off
 Electronic Flame Sensor
 Direct Spark Ignition
 Aluminized Steel Inshot Burners
 If configured for room sensor control, additional staging may be possible. Refer to performance tables within the EHB

Control System

Fan and Limit Controls
 Overload Protection
 Microprocessor Controls – Lennox® CORE Control System
 Auto reset high & low pressure switch with strike 3 lockout feature in Lennox® CORE Control System
 Limited warranty on Lennox® CORE Control System of 3 years
 Built-in BACnet IP & MS/TP



Lennox National Accounts Project Submittal

Phase/Voltage Detection

Compliance

All models are ASHRAE 90.1-2019 energy efficiency compliant and meet or exceed requirements of Section 6.8

All models meet DOE 2018 and 2023 energy efficiency standards

Model meets California Code of Regulations, Title 24 and ASHRAE 90.1-2016 Section 6.4.3.10 requirements for staged airflow

Model meets HCAI (formerly OSHPD) OSP and Special Seismic Certification (Number: OSP-0596) and meet 2018 International Building Code (IBC), 2019

California Building Code (CBC) ASCE 7, and ICC-ES AC156

ISO 9001 Registered Manufacturing Quality System

Warranty

Limited warranty on aluminized heat exchanger of 10 years

Limited warranty on compressor of 5 years

Limited warranty on Environ Coil System of 3 years

Limited warranty on High Performance Economizer of 5 years

Limited warranty on all other components of 1 year

See Limited Warranty Certificate included with unit for details



Lennox National Accounts Project Submittal

Corner Weights (lb)								Center of Gravity (in.)			
AA		BB		CC		DD		EE		FF	
Base	Max	Base	Max	Base	Max	Base	Max	Base	Max	Base	Max
512	624	620	709	787	809	650	712	58.99	57.31	40.16	42.54

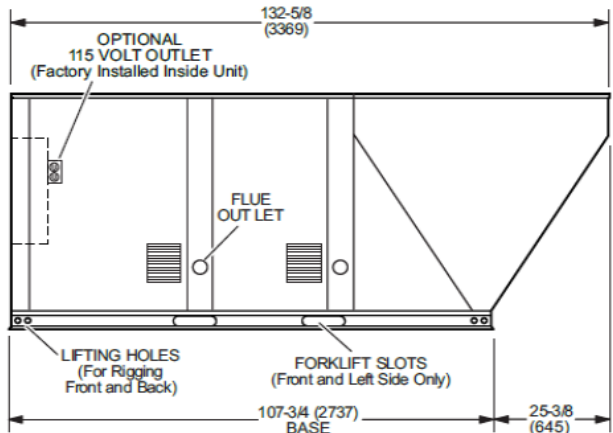
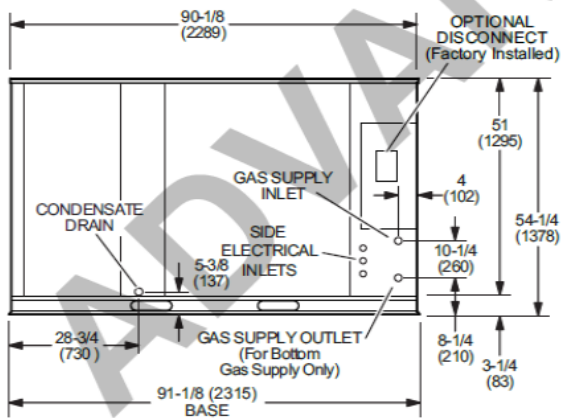
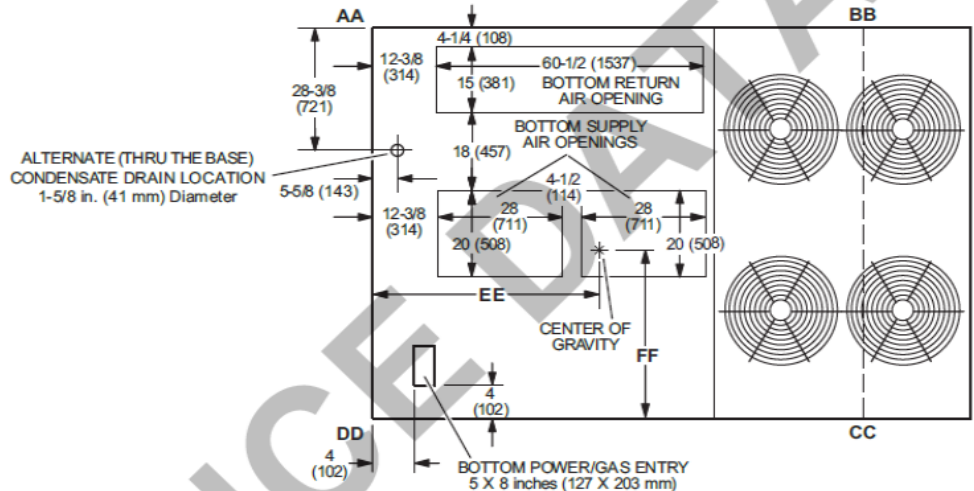



Lennox National Accounts Project Submittal

OUTDOOR AIR HOOD DETAIL

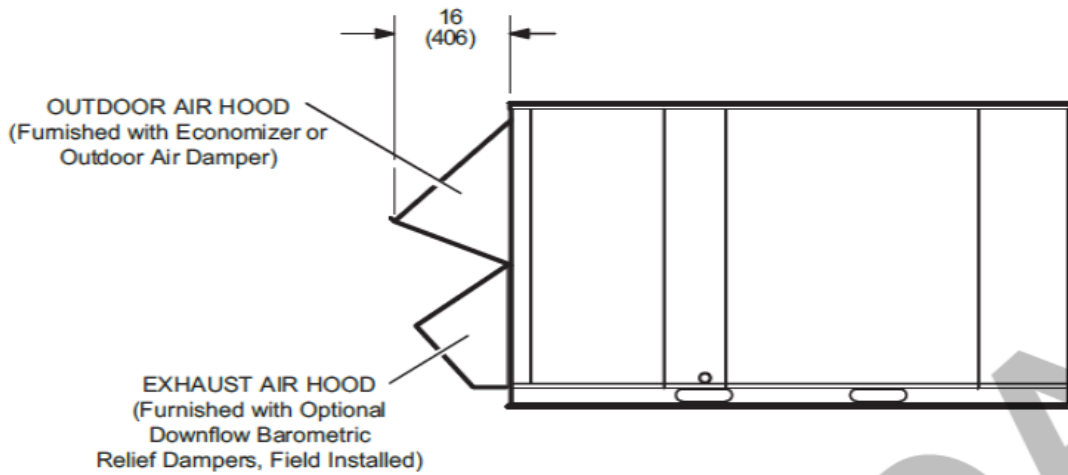

OPTIONAL HORIZONTAL BAROMETRIC RELIEF DAMPERS WITH HOOD (Field installed in horizontal return air duct adjacent to unit)

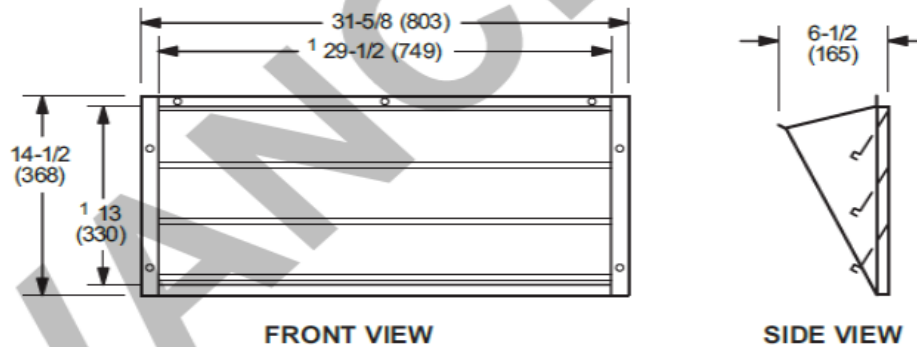

NOTE - Two furnished per order no.
¹ NOTE - Opening size required in return air duct.



Lennox National Accounts Project Submittal

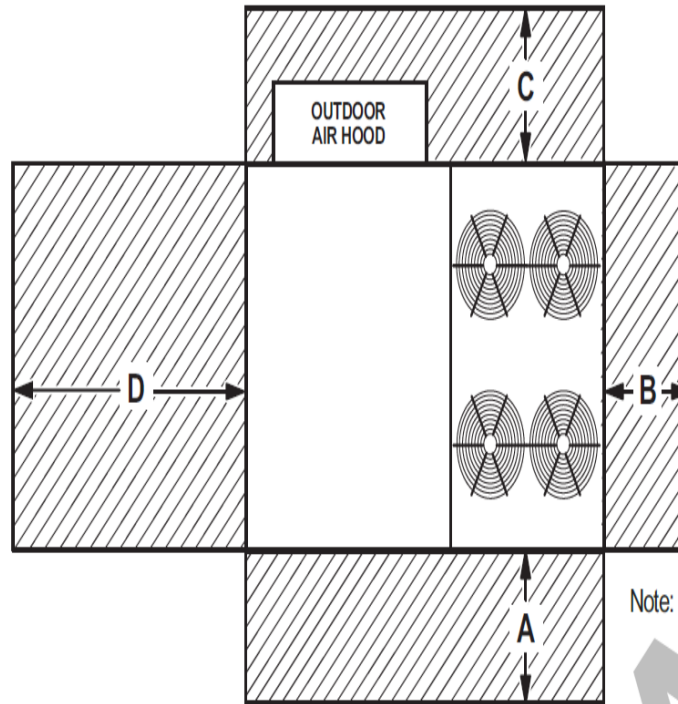

Note: Models with four outdoor fans shown.
Dimension clearances are for all sizes.

¹ Unit Clearance	A		B		C		D		Top Clearance
	in.	mm	in.	mm	in.	mm	in.	mm	
Service Clearance	60	1524	36	914	36	934	66	1676	Unobstructed
Clearance to Combustibles	36	914	1	25	1	25	1	25	
Minimum Operation Clearance	45	1143	36	914	36	914	41	1041	

NOTE - Entire perimeter of unit base requires support when elevated above the mounting surface.

¹ Service Clearance - Required for removal of serviceable parts.

Clearance to Combustibles - Required clearance to combustible material.



Lennox National Accounts Project Submittal

Tag: RTU 5
Model: LGT048H4E - LGT048H4E-G 4T CONF S=17

UNIT OVERVIEW

Voltage	SEER EER	MCA/MOCP (amp)	Gross Cooling Ttl/Sens (MBH)	Net Cooling Ttl/Sens (MBH)	Supply Air Flow (cfm)	ESP/TSP (in.WC)	EAT DB/WB (°F)	LAT DB/WB (°F)
460V 3Ph 60Hz	17 12.8	13 / 15	49.6 / 34.7	47.4 / 32.5	1,600	0.50 / 0.68	80.0 / 67.0	59.0 / 56.7

COOLING

Cooling Performance			Temperatures (DB/WB °F)		
Gross Cooling (Ttl/Sens)	49.6 / 34.7 MBH		Ambient	95.0	
Net Cooling (Ttl/Sens)	47.4 / 32.5 MBH		Entering	80.0	67.0
Coil Moisture Removal	14.02 lb/hr		Leaving - (Coil)	59.0	56.7
System Moisture Removal	14.02 lb/hr		Leaving - (Unit)	60.4	57.3

ARI Performance		Compressors		Refrigerant		Condensate Drain	
ARI Cooling	50.1 / 49.0 MBH	Cooling Stages	2.0	Type	R-410A	Qty	1
ARI Power	3,800 W	Compressor Qty	1	Charge	5 LBS. 4 OZ.	Size	1 in.
		Compressor RLA	5.7 amp			Pipe Thread	npt

HEATING

Heating Performance		Temperatures (DB/WB °F)		Specifications	
Output (High/Low)	121.0 / 92.0 MBH	Leaving	69.4	Heat Stages	2
Input (High/Low)	150.0 / 113.0 MBH			Thermal Efficiency NOX	81.0%
Heat Rise	69.4 °F			Gas Line Size	0.5 in.
				Gas Pressure	7 in.WC

VENTILATION

Air Flow (cfm)		Supply Fan		Air Resistance (in.WC)	
Supply	1,600	Nominal Power	1.00 hp	Total	0.68
	0	Required Power	0.69 hp	Ext Supply	0.50
		Drive Type	ECM Direct Drive		
		Required Watts	515 W		
		Motor Torque	56		

AIR RESISTANCE - OPTIONS/ACCESSORIES (in.WC)

Wet Coil	Humiditrol	Heat	Economizer	Filters	Diffuser	Exhaust	ERW
0.06		0.04	0.04	0.04			

ELECTRICAL

Voltage	460V 3Ph / 60Hz	Compressor RLA	5.7 amp
MCA	13 amp	Cooling FLA Total	10.8 amp
MOCP	15 amp	Condenser FLA	1.4 amp
Condenser Power	300 W	Supply Fan FLA	3.7 amp
Oper Range-Nom Volt	+/- 10%		

ADDITIONAL DATA

Cabinet	85.25 in. x 47.00 in. x 46.88 in.	Total Weight	779 lb
Downflow Supply	20.0 in. x 18.0 in.	Base Unit Net Weight	629 lb
Downflow Return	29.0 in. x 11.0 in.	OAS/Econ Weight	131 lb
Filters	(4) 20.0 in. x 20.0 in. x 2.0 in.	Gas Heat Weight	19 lb
Sound Rating	75 dBA		



Lennox National Accounts Project Submittal

Tag: RTU 5

Factory Installed Options

- High Performance Economizer Upgrade Factory Installed
- Single Enthalpy High Performance Economizer
- Direct Drive
- Unit Orientation Downflow
- Supply Fan: Multi-Speed ECM Direct Drive
- 440V/460V/480V 3Phase
- 80Amp Disconnect Factory Installed
- Built-in BACnet IP and MS/TP (standard)
- Supply Motor - 1.0 Hp ECM - Multi-Speed Direct Drive
- Barometric Relief Damper (Fac)
- 150K A.S. (Dual Stage)
- Low Nox Factory Installed
- Combination Coil/Hail Guards Factory Installed
- Hinged Access Doors Factory Installed
- 15A GFCI Factory Installed/Field Wired
- Phase/Voltage Detection Factory Installed
- Supply Air Smoke Detector Factory Installed
- Return Air Smoke Detector Factory Installed
- Environ Condenser Coil System Factory Installed
- 2" MERV8 - Filter Factory installed

Field Installed Accessories

Catalog Number	Qty	Description
Y3027	1	BE RTS2-AOS Multi Signal Accessory

Product Features

Cabinet

- Hinged Access Panels
- Durable Outdoor Enamel Paint Finish
- Totally Enclosed Outdoor Fan Motor
- PVC Coated Fan Guard
- Corrosion-Resistant Removable, Reversible Drain Pan
- Isolated Compressor Compartment

Cooling System

- Scroll Compressor
- Expansion Valves
- High Capacity Driers
- Crankcase Heater
- System can operate from 0°F to 125°F without any additional controls
- Pre-charged Refrigeration System
- Internal Pressure Relief Valve

Heating System

- Redundant Automatic Gas Valve with Manual Shut-off
- Electronic Flame Sensor
- Direct Spark Ignition
- Aluminized Steel Inshot Burners
- If configured for room sensor control, additional staging may be possible. Refer to performance tables within the EHB

Control System

- Fan and Limit Controls
- Overload Protection
- Microprocessor Controls – Lennox® CORE Control System
- Auto reset high & low pressure switch with strike 3 lockout feature in Lennox® CORE Control System
- Limited warranty on Lennox® CORE Control System of 3 years
- Built-in BACnet IP & MS/TP

Compliance

- All models are ASHRAE 90.1-2019 energy efficiency compliant and meet or exceed requirements of Section 6.8
- All models meet DOE 2018 and 2023 energy efficiency standards
- Model meets California Code of Regulations, Title 24 and ASHRAE 90.1-2016 Section 6.4.3.10 requirements for staged airflow



Lennox National Accounts Project Submittal

Model meets HCAI (formerly OSHPD) OSP and Special Seismic Certification (Number: OSP-0596) and meet 2018 International Building Code (IBC), 2019 California Building Code (CBC) ASCE 7, and ICC-ES AC156
ISO 9001 Registered Manufacturing Quality System

Warranty

Limited warranty on aluminized heat exchanger of 10 years
Limited warranty on compressor of 5 years
Limited warranty on Environ Coil System of 3 years
Limited warranty on High Performance Economizer of 5 years
Limited warranty on all other components of 1 year
See Limited Warranty Certificate included with unit for details



Lennox National Accounts Project Submittal

Corner Weights (lb)						Center of Gravity (in.)					
AA		BB		CC		DD		EE		FF	
Base	Max	Base	Max	Base	Max	Base	Max	Base	Max	Base	Max
131	168	161	207	220	283	179	230	38.25	39.75	19.88	19.88

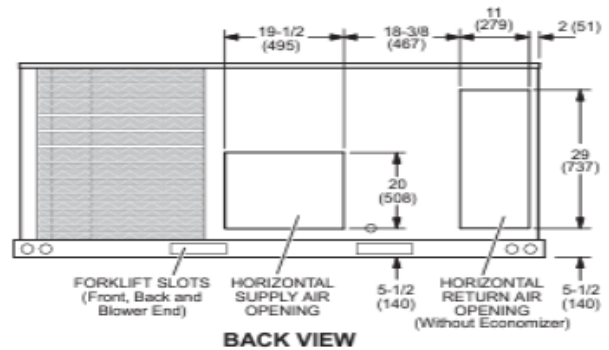
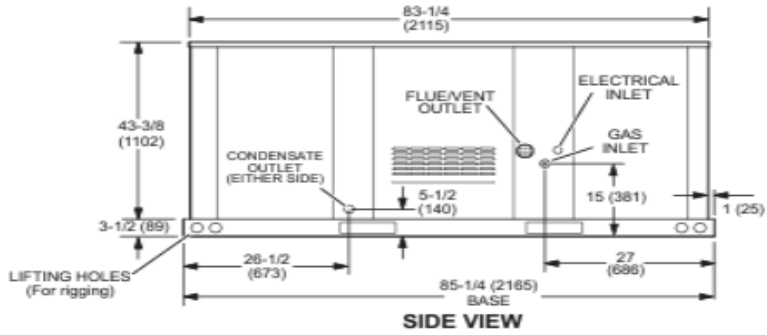
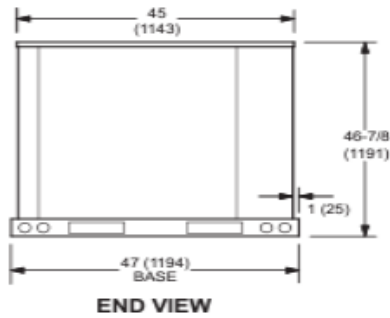
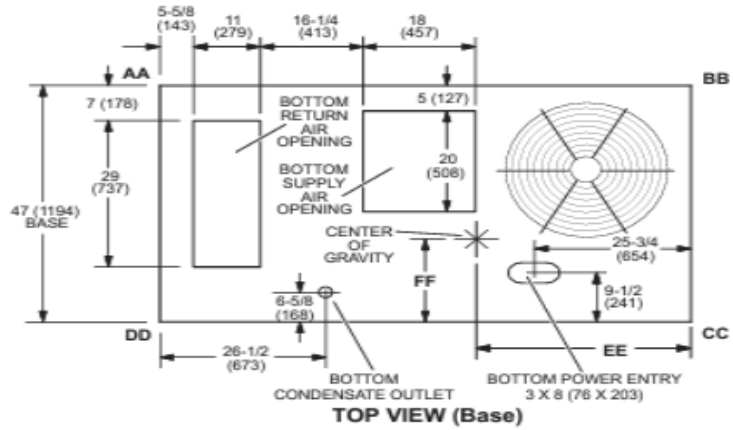



Lennox National Accounts Project Submittal

UNIT CLEARANCES

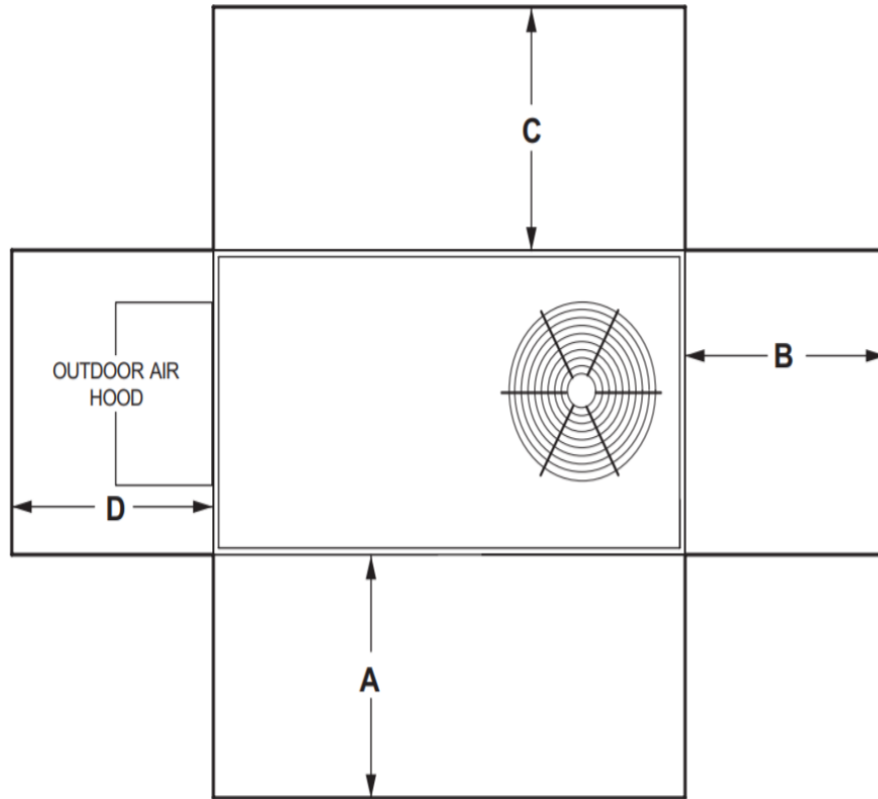

¹ Unit Clearance	A		B		C		D		Top Clearance
	in.	mm	in.	mm	in.	mm	in.	mm	
Service Clearance	48	1219	36	914	36	934	36	914	Unobstructed
Clearance to Combustibles	36	914	1	25	1	25	1	25	
Minimum Operation Clearance	36	914	36	914	36	914	36	914	

NOTE - Entire perimeter of unit base requires support when elevated above the mounting surface.

¹ **Service Clearance** - Required for removal of serviceable parts.

Clearance to Combustibles - Required clearance to combustible material.

Minimum Operation Clearance - Required clearance for proper unit operation.



Lennox National Accounts Project Submittal

Tag: RTU 6
 Model: LGT060H4E - LGT060H4E-G 5T CONF S=17

UNIT OVERVIEW

Voltage	SEER EER	MCA/MOCP (amp)	Gross Cooling Ttl/Sens (MBH)	Net Cooling Ttl/Sens (MBH)	Supply Air Flow (cfm)	ESP/TSP (in.WC)	EAT DB/WB (°F)	LAT DB/WB (°F)
460V 3Ph 60Hz	17 12.7	12 / 15	63.0 / 47.2	60.4 / 44.7	2,000	0.50 / 0.76	80.0 / 67.0	57.2 / 56.5

COOLING

Cooling Performance			Temperatures (DB/WB °F)		
Gross Cooling (Ttl/Sens)	63.0 / 47.2 MBH		Ambient	95.0	
Net Cooling (Ttl/Sens)	60.4 / 44.7 MBH		Entering	80.0	67.0
Coil Moisture Removal	14.84 lb/hr		Leaving - (Coil)	57.2	56.5
System Moisture Removal	14.84 lb/hr		Leaving - (Unit)	58.4	57.0

ARI Performance		Compressors		Refrigerant		Condensate Drain	
ARI Cooling	61.6 / 60.0 MBH	Cooling Stages	2.0	Type	R-410A	Qty	1
ARI Power	4,600 W	Compressor Qty	1	Charge	4 LBS. 13 OZ.	Size	1 in.
		Compressor RLA	6.5 amp			Pipe Thread	npt

HEATING

Heating Performance		Temperatures (DB/WB °F)		Specifications	
Output (High/Low)	121.0 / 92.0 MBH	Leaving	55.6	Heat Stages	2
Input (High/Low)	150.0 / 113.0 MBH			Thermal Efficiency NOX	81.0%
Heat Rise	55.6 °F			Gas Line Size	0.5 in.
				Gas Pressure	7 in.WC

VENTILATION

Air Flow (cfm)		Supply Fan		Air Resistance (in.WC)	
Supply	2,000	Nominal Power	1.50 hp	Total	0.76
	0	Required Power	0.81 hp	Ext Supply	0.50
		Drive Type	MSAV Direct Drive		
		Required Watts	604 W		

AIR RESISTANCE - OPTIONS/ACCESSORIES (in.WC)

Wet Coil	Humiditrol	Heat	Economizer	Filters	Diffuser	Exhaust	ERW
0.10		0.06	0.05	0.05			

ELECTRICAL

Voltage	460V 3Ph / 60Hz	Compressor RLA	6.5 amp
MCA	12 amp	Cooling FLA Total	10.2 amp
MOCP	15 amp	Condenser FLA	1.4 amp
Condenser Power	350 W	Supply Fan FLA	2.3 amp
Oper Range-Nom Volt	+/- 10%		

ADDITIONAL DATA

Cabinet	85.25 in. x 47.00 in. x 46.88 in.	Total Weight	780 lb
Downflow Supply	20.0 in. x 18.0 in.	Base Unit Net Weight	630 lb
Downflow Return	29.0 in. x 11.0 in.	OAS/Econ Weight	131 lb
Filters	(4) 20.0 in. x 20.0 in. x 2.0 in.	Gas Heat Weight	19 lb
Sound Rating	82 dBA		



Lennox National Accounts Project Submittal

Tag: RTU 6

Factory Installed Options

- High Performance Economizer Upgrade Factory Installed
- Single Enthalpy High Performance Economizer
- Direct Drive
- Unit Orientation Downflow
- Supply Fan: Multi-Speed ECM Direct Drive
- 440V/460V/480V 3Phase
- 80Amp Disconnect Factory Installed
- Built-in BACnet IP and MS/TP (standard)
- Supply Motor - 1.5 Hp ECM - w/ MSAV
- Barometric Relief Damper (Fac)
- 150K A.S. (Dual Stage)
- Low Nox Factory Installed
- Combination Coil/Hail Guards Factory Installed
- Hinged Access Doors Factory Installed
- 15A GFCI Factory Installed/Field Wired
- Phase/Voltage Detection Factory Installed
- Supply Air Smoke Detector Factory Installed
- Return Air Smoke Detector Factory Installed
- Environ Condenser Coil System Factory Installed
- 2" MERV8 - Filter Factory installed

Field Installed Accessories

Catalog Number	Qty	Description
Y3027	1	BE RTS2-AOS Multi Signal Accessory

Product Features

Cabinet

- Hinged Access Panels
- Durable Outdoor Enamel Paint Finish
- Totally Enclosed Outdoor Fan Motor
- PVC Coated Fan Guard
- Corrosion-Resistant Removable, Reversible Drain Pan
- Isolated Compressor Compartment

Cooling System

- Scroll Compressor
- Expansion Valves
- High Capacity Driers
- Crankcase Heater
- System can operate from 0°F to 125°F without any additional controls
- Pre-charged Refrigeration System
- Internal Pressure Relief Valve

Heating System

- Redundant Automatic Gas Valve with Manual Shut-off
- Electronic Flame Sensor
- Direct Spark Ignition
- Aluminized Steel Inshot Burners
- If configured for room sensor control, additional staging may be possible. Refer to performance tables within the EHB

Control System

- Fan and Limit Controls
- Overload Protection
- Microprocessor Controls – Lennox® CORE Control System
- Auto reset high & low pressure switch with strike 3 lockout feature in Lennox® CORE Control System
- Limited warranty on Lennox® CORE Control System of 3 years
- Built-in BACnet IP & MS/TP

Compliance

- All models are ASHRAE 90.1-2019 energy efficiency compliant and meet or exceed requirements of Section 6.8
- All models meet DOE 2018 and 2023 energy efficiency standards
- Model meets California Code of Regulations, Title 24 and ASHRAE 90.1-2016 Section 6.4.3.10 requirements for staged airflow



Lennox National Accounts Project Submittal

Model meets HCAI (formerly OSHPD) OSP and Special Seismic Certification (Number: OSP-0596) and meet 2018 International Building Code (IBC), 2019 California Building Code (CBC) ASCE 7, and ICC-ES AC156
ISO 9001 Registered Manufacturing Quality System

Warranty

Limited warranty on aluminized heat exchanger of 10 years
Limited warranty on compressor of 5 years
Limited warranty on Environ Coil System of 3 years
Limited warranty on High Performance Economizer of 5 years
Limited warranty on all other components of 1 year
See Limited Warranty Certificate included with unit for details



Lennox National Accounts Project Submittal

Corner Weights (lb)						Center of Gravity (in.)					
AA		BB		CC		DD		EE		FF	
Base	Max	Base	Max	Base	Max	Base	Max	Base	Max	Base	Max
131	168	161	207	220	283	179	230	38.25	39.75	19.88	19.88

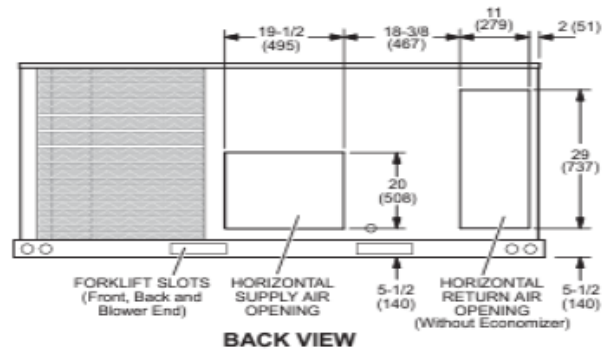
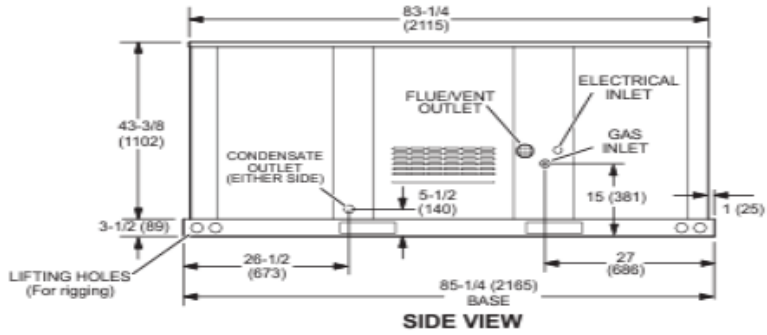
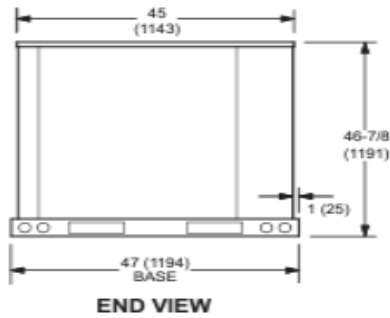
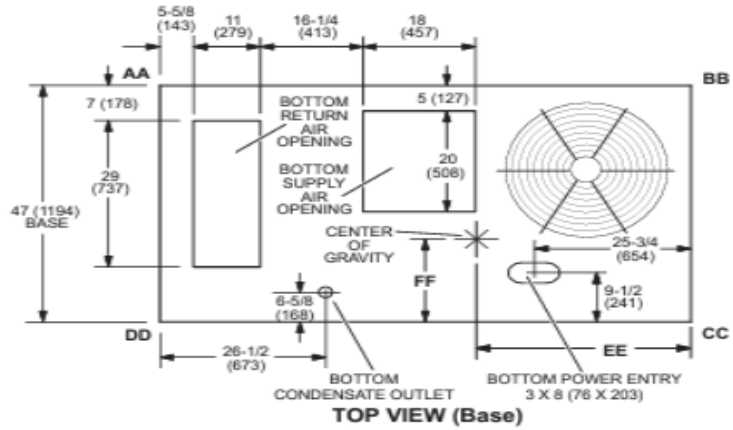



Lennox National Accounts Project Submittal

UNIT CLEARANCES

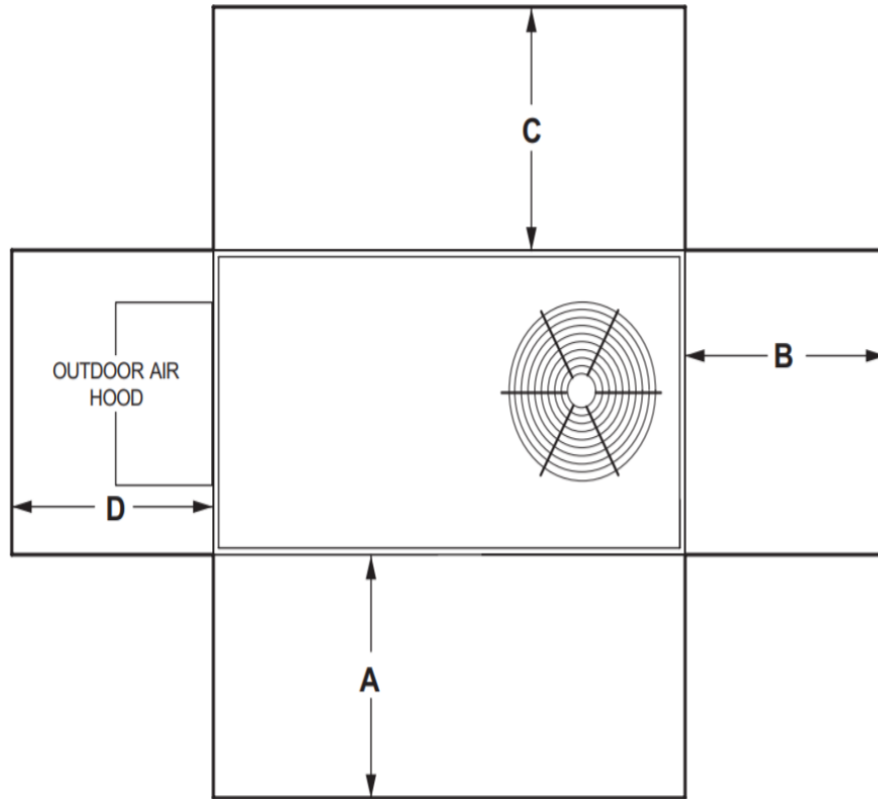

¹ Unit Clearance	A		B		C		D		Top Clearance
	in.	mm	in.	mm	in.	mm	in.	mm	
Service Clearance	48	1219	36	914	36	934	36	914	Unobstructed
Clearance to Combustibles	36	914	1	25	1	25	1	25	
Minimum Operation Clearance	36	914	36	914	36	914	36	914	

NOTE - Entire perimeter of unit base requires support when elevated above the mounting surface.

¹ **Service Clearance** - Required for removal of serviceable parts.

Clearance to Combustibles - Required clearance to combustible material.

Minimum Operation Clearance - Required clearance for proper unit operation.



Lennox National Accounts Project Submittal

Tag: RTU 7
Model: LGT036H4E - LGT036H4E-G 3T CONF S=17.0

UNIT OVERVIEW

Voltage	SEER EER	MCA/MOCP (amp)	Gross Cooling Ttl/Sens (MBH)	Net Cooling Ttl/Sens (MBH)	Supply Air Flow (cfm)	ESP/TSP (in.WC)	EAT DB/WB (°F)	LAT DB/WB (°F)
460V 3Ph 60Hz	17 13.3	9 / 15	37.0 / 26.6	35.7 / 25.3	1,200	0.50 / 0.62	80.0 / 67.0	58.6 / 56.8

COOLING

Cooling Performance		Temperatures (DB/WB °F)	
Gross Cooling (Ttl/Sens)	37.0 / 26.6 MBH	Ambient	95.0
Net Cooling (Ttl/Sens)	35.7 / 25.3 MBH	Entering	80.0 67.0
Coil Moisture Removal	9.76 lb/hr	Leaving - (Coil)	58.6 56.8
System Moisture Removal	9.76 lb/hr	Leaving - (Unit)	59.6 57.2

ARI Performance		Compressors		Refrigerant		Condensate Drain	
ARI Cooling	36.6 / 36.0 MBH	Cooling Stages	2.0	Type	R-410A	Qty	1
ARI Power	2,700 W	Compressor Qty	1	Charge	5 LBS. 11 OZ.	Size	1 in.
		Compressor RLA	4 amp			Pipe Thread	npt

HEATING

Heating Performance		Temperatures (DB/WB °F)		Specifications	
Output (High/Low)	87.0 / 66.0 MBH	Leaving	66.4	Heat Stages	2
Input (High/Low)	108.0 / 81.0 MBH			Thermal Efficiency NOX	81.0%
Heat Rise	66.4 °F			Gas Line Size	0.5 in.
				Gas Pressure	7 in.WC

VENTILATION

Air Flow (cfm)		Supply Fan		Air Resistance (in.WC)	
Supply	1,200	Nominal Power	0.50 hp	Total	0.62
	0	Required Power	0.41 hp	Ext Supply	0.50
		Drive Type	ECM Direct Drive		
		Required Watts	308 W		
		Motor Torque	66		

AIR RESISTANCE - OPTIONS/ACCESSORIES (in.WC)

Wet Coil	Humiditrol	Heat	Economizer	Filters	Diffuser	Exhaust	ERW
0.03		0.02	0.04	0.03			

ELECTRICAL

Voltage	460V 3Ph / 60Hz	Compressor RLA	4.0 amp
MCA	9 amp	Cooling FLA Total	7.6 amp
MOCP	15 amp	Condenser FLA	1.4 amp
Condenser Power	175 W	Supply Fan FLA	2.2 amp
Oper Range-Nom Volt	+/- 10%		

ADDITIONAL DATA

Cabinet	85.25 in. x 47.00 in. x 46.88 in.	Total Weight	769 lb
Downflow Supply	20.0 in. x 18.0 in.	Base Unit Net Weight	630 lb
Downflow Return	29.0 in. x 11.0 in.	OAS/Econ Weight	131 lb
Filters	(4) 20.0 in. x 20.0 in. x 2.0 in.	Gas Heat Weight	8 lb
Sound Rating	75 dBA		



Lennox National Accounts Project Submittal

Tag: RTU 7

Factory Installed Options

- High Performance Economizer Upgrade Factory Installed
- Single Enthalpy High Performance Economizer
- Direct Drive
- Unit Orientation Downflow
- Supply Fan: Multi-Speed ECM Direct Drive
- 440V/460V/480V 3Phase
- 80Amp Disconnect Factory Installed
- Built-in BACnet IP and MS/TP (standard)
- Supply Motor - 0.50 Hp ECM - w/ MSAV
- Barometric Relief Damper (Fac)
- 108K A.S. (Dual Stage)
- Low Nox Factory Installed
- Combination Coil/Hail Guards Factory Installed
- Hinged Access Doors Factory Installed
- 15A GFCI Factory Installed/Field Wired
- Phase/Voltage Detection Factory Installed
- Supply Air Smoke Detector Factory Installed
- Return Air Smoke Detector Factory Installed
- Environ Condenser Coil System Factory Installed
- 2" MERV8 - Filter Factory installed

Field Installed Accessories

Catalog Number	Qty	Description
Y3027	1	BE RTS2-AOS Multi Signal Accessory

Product Features

Cabinet

- Hinged Access Panels
- Durable Outdoor Enamel Paint Finish
- Totally Enclosed Outdoor Fan Motor
- PVC Coated Fan Guard
- Corrosion-Resistant Removable, Reversible Drain Pan
- Isolated Compressor Compartment

Cooling System

- Scroll Compressor
- Expansion Valves
- High Capacity Driers
- Crankcase Heater
- System can operate from 0°F to 125°F without any additional controls
- Pre-charged Refrigeration System
- Internal Pressure Relief Valve

Heating System

- Redundant Automatic Gas Valve with Manual Shut-off
- Electronic Flame Sensor
- Direct Spark Ignition
- Aluminized Steel Inshot Burners
- If configured for room sensor control, additional staging may be possible. Refer to performance tables within the EHB

Control System

- Fan and Limit Controls
- Overload Protection
- Microprocessor Controls – Lennox® CORE Control System
- Auto reset high & low pressure switch with strike 3 lockout feature in Lennox® CORE Control System
- Limited warranty on Lennox® CORE Control System of 3 years
- Built-in BACnet IP & MS/TP

Compliance

- All models are ASHRAE 90.1-2019 energy efficiency compliant and meet or exceed requirements of Section 6.8
- All models meet DOE 2018 and 2023 energy efficiency standards
- Model meets California Code of Regulations, Title 24 and ASHRAE 90.1-2016 Section 6.4.3.10 requirements for staged airflow



Lennox National Accounts Project Submittal

Model meets HCAI (formerly OSHPD) OSP and Special Seismic Certification (Number: OSP-0596) and meet 2018 International Building Code (IBC), 2019 California Building Code (CBC) ASCE 7, and ICC-ES AC156
ISO 9001 Registered Manufacturing Quality System

Warranty

Limited warranty on aluminized heat exchanger of 10 years
Limited warranty on compressor of 5 years
Limited warranty on Environ Coil System of 3 years
Limited warranty on High Performance Economizer of 5 years
Limited warranty on all other components of 1 year
See Limited Warranty Certificate included with unit for details



Lennox National Accounts Project Submittal

Corner Weights (lb)						Center of Gravity (in.)					
AA		BB		CC		DD		EE		FF	
Base	Max	Base	Max	Base	Max	Base	Max	Base	Max	Base	Max
131	168	161	207	220	283	179	230	38.25	39.75	19.88	19.88

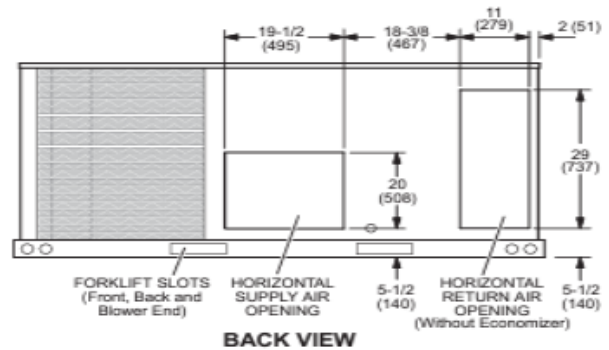
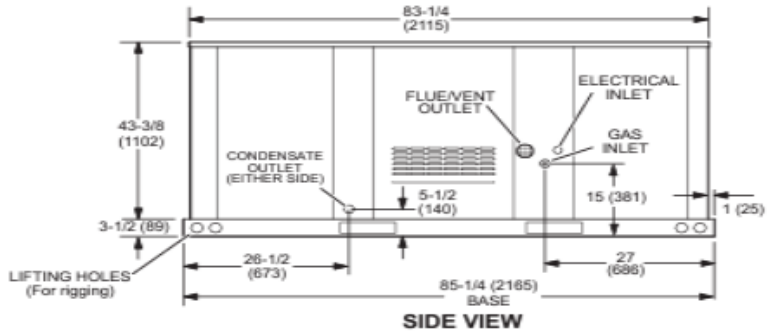
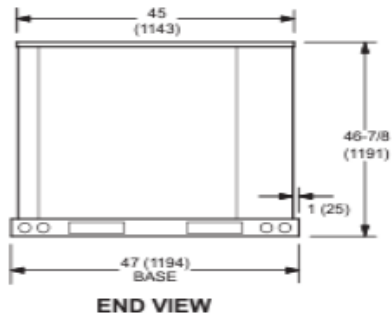
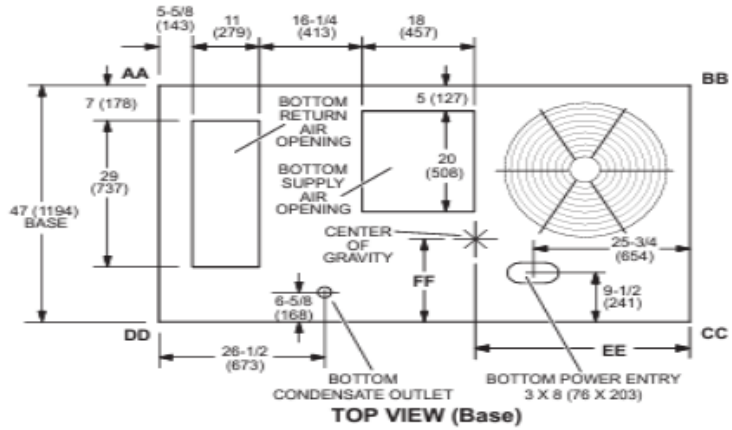



Lennox National Accounts Project Submittal

UNIT CLEARANCES

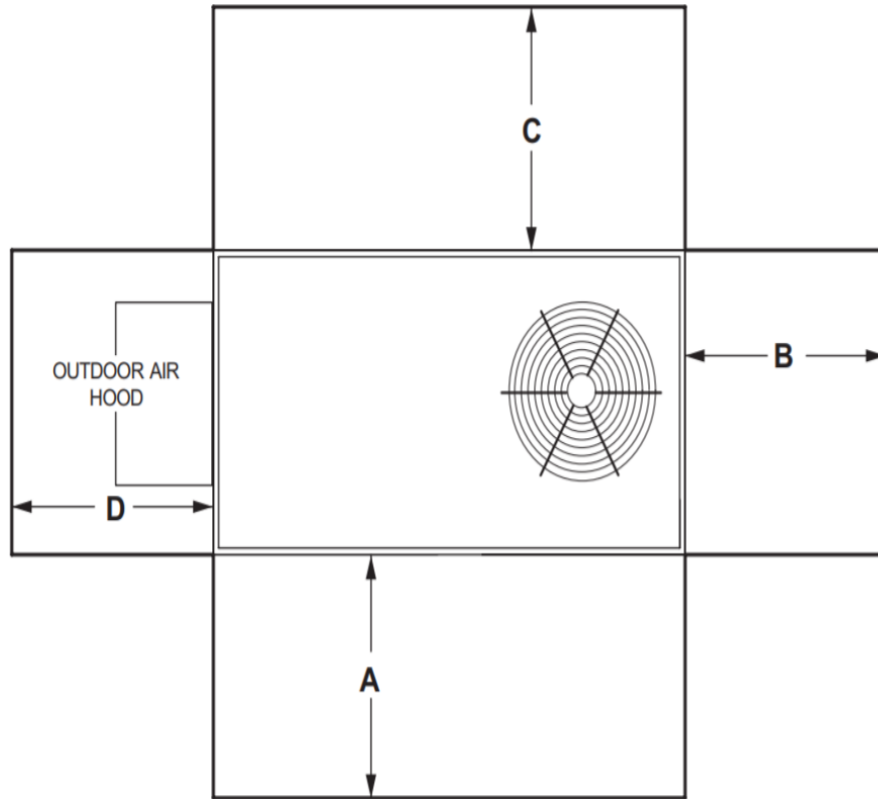

¹ Unit Clearance	A		B		C		D		Top Clearance
	in.	mm	in.	mm	in.	mm	in.	mm	
Service Clearance	48	1219	36	914	36	934	36	914	Unobstructed
Clearance to Combustibles	36	914	1	25	1	25	1	25	
Minimum Operation Clearance	36	914	36	914	36	914	36	914	

NOTE - Entire perimeter of unit base requires support when elevated above the mounting surface.

¹ **Service Clearance** - Required for removal of serviceable parts.

Clearance to Combustibles - Required clearance to combustible material.

Minimum Operation Clearance - Required clearance for proper unit operation.



Lennox National Accounts Project Submittal

Tag: RTU 8
Model: LGT120H4E - LGT120H4E-G 10T CONF E=12.1

UNIT OVERVIEW

Voltage	IEER EER	MCA/MOCP (amp)	Gross Cooling Ttl/Sens (MBH)	Net Cooling Ttl/Sens (MBH)	Supply Air Flow (cfm)	ESP/TSP (in.WC)	EAT DB/WB (°F)	LAT DB/WB (°F)
460V 3Ph 60Hz	15.5 12.1	26 / 30	121.9 / 89.0	114.1 / 81.2	4,000	0.50 / 1.09	80.0 / 67.0	58.5 / 56.9

COOLING

Cooling Performance		Temperatures (DB/WB °F)	
Gross Cooling (Ttl/Sens)	121.9 / 89.0 MBH	Ambient	95.0
Net Cooling (Ttl/Sens)	114.1 / 81.2 MBH	Entering	80.0 67.0
Coil Moisture Removal	31.02 lb/hr	Leaving - (Coil)	58.5 56.9
System Moisture Removal	31.02 lb/hr	Leaving - (Unit)	60.4 57.6

ARI Performance		Compressors		Refrigerant		Condensate Drain	
ARI Cooling	117.0 / 114.0 MBH	Cooling Stages	3.0	Type	R-410A	Qty	1
ARI Power	9,500 W	Compressor Qty	2	Charge	14 LBS. 0 OZ.	Size	1 in.
		Compressor RLA	14.9 amp			Pipe Thread	npt

HEATING

Heating Performance		Temperatures (DB/WB °F)		Specifications	
Output (High/Low)	194.0 / 126.4 MBH	Leaving	44.9	Heat Stages	2
Input (High/Low)	240.0 / 156.0 MBH			Thermal Efficiency	81.0%
Heat Rise	44.9 °F			Gas Line Size	0.75 in.
				Gas Pressure	7 in.WC

VENTILATION

Air Flow (cfm)		Supply Fan		Air Resistance (in.WC)	
Supply	4,000	Nominal Power	3.75 hp	Total	1.09
	0	Required Power	2.46 hp	Ext Supply	0.50
		Drive Type	ECM Direct Drive		
		Required Watts	1,831 W		

AIR RESISTANCE - OPTIONS/ACCESSORIES (in.WC)

Wet Coil	Humiditrol	Heat	Economizer	Filters	Diffuser	Exhaust	ERW
0.14		0.22	0.19	0.04			

ELECTRICAL

Voltage	460V 3Ph / 60Hz	Compressor RLA	14.9 amp
MCA	26 amp	Cooling FLA Total	22.6 amp
MOCP	30 amp	Condenser FLA	3.0 amp
Condenser Power	1000 W	Supply Fan FLA	4.7 amp
Oper Range-Nom Volt	+/- 10%		

ADDITIONAL DATA

Cabinet	101.25 in. x 60.12 in. x 46.88 in.	Total Weight	1,356 lb
Downflow Supply	20.0 in. x 28.0 in.	Base Unit Net Weight	1,210 lb
Downflow Return	24.0 in. x 27.0 in.	OAS/Econ Weight	83 lb
Filters	(4) 20.0 in. x 25.0 in. x 2.0 in.	Gas Heat Weight	32 lb
Sound Rating	90 dBA		



Lennox National Accounts Project Submittal

Tag: RTU 8

Factory Installed Options

- High Performance Economizer Upgrade Factory Installed
- Single Enthalpy High Performance Economizer
- Direct Drive
- Unit Orientation Downflow
- Supply Fan: Multi-Speed ECM Direct Drive
- 440V/460V/480V 3Phase
- 80Amp Disconnect Factory Installed
- Built-in BACnet IP and MS/TP (standard)
- Supply Motor - 3.75 Hp - DirectPlus w/MSAV
- Std Static Power Exhaust Fan
- 240K A.S. (Dual Stage)
- Combination Coil/Hail Guards Factory Installed
- Hinged Access Doors Factory Installed
- 15A GFCI Factory Installed/Field Wired
- Supply Air Smoke Detector Factory Installed
- Return Air Smoke Detector Factory Installed
- Environ Condenser Coil System Factory Installed
- 2" MERV8 - Filter Factory installed

Field Installed Accessories

Catalog Number	Qty	Description
87N53	1	CO2 Sensors - Wall-mount, off-white plastic cover, no display Field Installed
Y3027	1	BE RTS2-AOS Multi Signal Accessory

Product Features

Cabinet

- Hinged Access Panels
- Durable Outdoor Enamel Paint Finish
- Totally Enclosed Outdoor Fan Motor
- PVC Coated Fan Guard
- Corrosion-Resistant Removable, Reversible Drain Pan
- Isolated Compressor Compartment

Cooling System

- Scroll Compressor
- Expansion Valves
- High Capacity Driers
- Crankcase Heater
- System can operate from 0°F to 125°F without any additional controls
- Pre-charged Refrigeration System
- Internal Pressure Relief Valve

Heating System

- Redundant Automatic Gas Valve with Manual Shut-off
- Electronic Flame Sensor
- Direct Spark Ignition
- Aluminized Steel Inshot Burners
- If configured for room sensor control, additional staging may be possible. Refer to performance tables within the EHB

Control System

- Fan and Limit Controls
- Overload Protection
- Microprocessor Controls – Lennox® CORE Control System
- Auto reset high & low pressure switch with strike 3 lockout feature in Lennox® CORE Control System
- Limited warranty on Lennox® CORE Control System of 3 years
- Built-in BACnet IP & MS/TP
- Phase/Voltage Detection

Compliance

- All models are ASHRAE 90.1-2019 energy efficiency compliant and meet or exceed requirements of Section 6.8
- All models meet DOE 2018 and 2023 energy efficiency standards
- Model meets California Code of Regulations, Title 24 and ASHRAE 90.1-2016 Section 6.4.3.10 requirements for staged airflow



Lennox National Accounts Project Submittal

Model meets HCAI (formerly OSHPD) OSP and Special Seismic Certification (Number: OSP-0596) and meet 2018 International Building Code (IBC), 2019 California Building Code (CBC) ASCE 7, and ICC-ES AC156
ISO 9001 Registered Manufacturing Quality System

Warranty

Limited warranty on aluminized heat exchanger of 10 years
Limited warranty on compressor of 5 years
Limited warranty on Environ Coil System of 3 years
Limited warranty on High Performance Economizer of 5 years
Limited warranty on all other components of 1 year
See Limited Warranty Certificate included with unit for details



Lennox National Accounts Project Submittal

Corner Weights (lb)								Center of Gravity (in.)			
AA		BB		CC		DD		EE		FF	
Base	Max	Base	Max	Base	Max	Base	Max	Base	Max	Base	Max
306	349	275	305	295	326	334	382	46.50	45.50	24.50	25.50

Model No.	DIMENSIONS																UNIT							
	CORNER WEIGHTS																CENTER OF GRAVITY							
	AA		BB		CC		DD		EE		FF		Base		Max.		Base		Max.					
	lbs.	kg	lbs.	kg	lbs.	kg	lbs.	kg	lbs.	kg	lbs.	kg	lbs.	kg	in.	mm	in.	mm	in.	mm				
092	293	133	338	153	263	119	295	134	286	130	316	143	326	148	370	168	46.5	1181	45.5	1156	24.5	622	25.5	648
102	294	134	340	154	265	120	297	135	288	131	318	144	328	149	372	169	46.5	1181	45.5	1156	24.5	622	25.5	648
120	306	139	349	158	275	125	305	138	295	134	326	148	334	152	382	173	46.5	1181	45.5	1156	24.5	622	25.5	648
150	316	143	359	163	284	129	314	142	304	138	393	178	345	157	393	178	46.5	1181	45.5	1156	24.5	622	25.5	648

Base Unit - The unit with NO INTERNAL OPTIONS.

Max. Unit - The unit with ALL INTERNAL OPTIONS Installed. (Economizer, Standard Static Power Exhaust Fans, Controls, etc.). Does not include accessories external to unit or high static power exhaust.

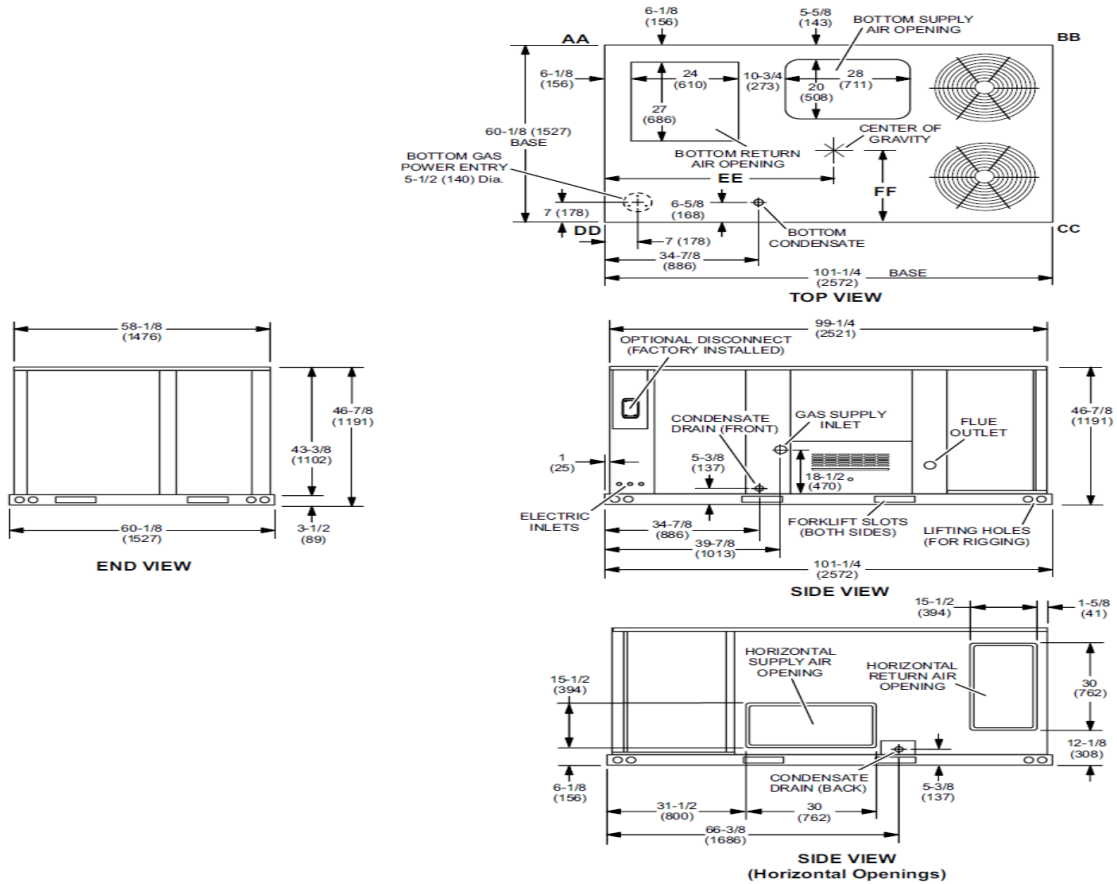

OUTDOOR AIR HOOD DETAIL

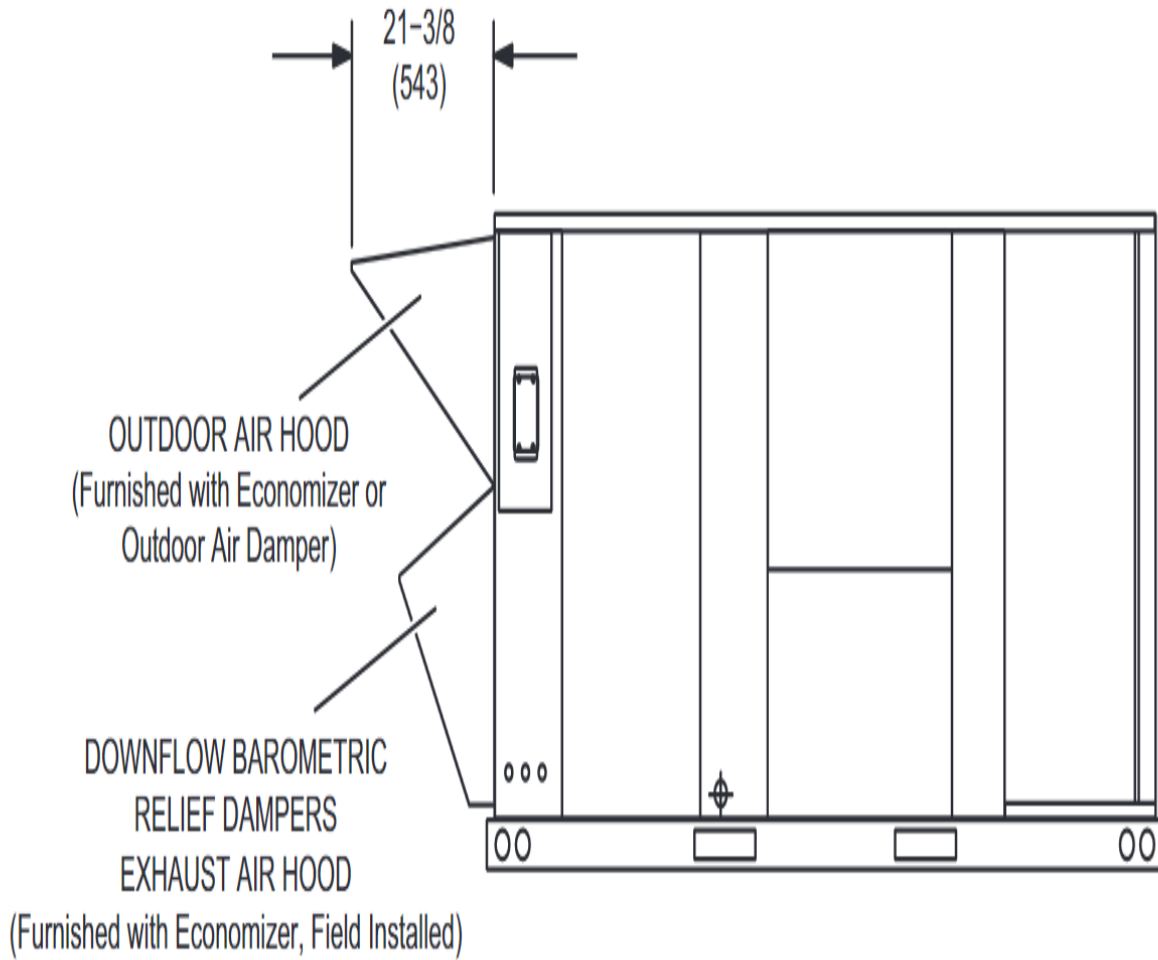



Lennox National Accounts Project Submittal

UNIT CLEARANCES

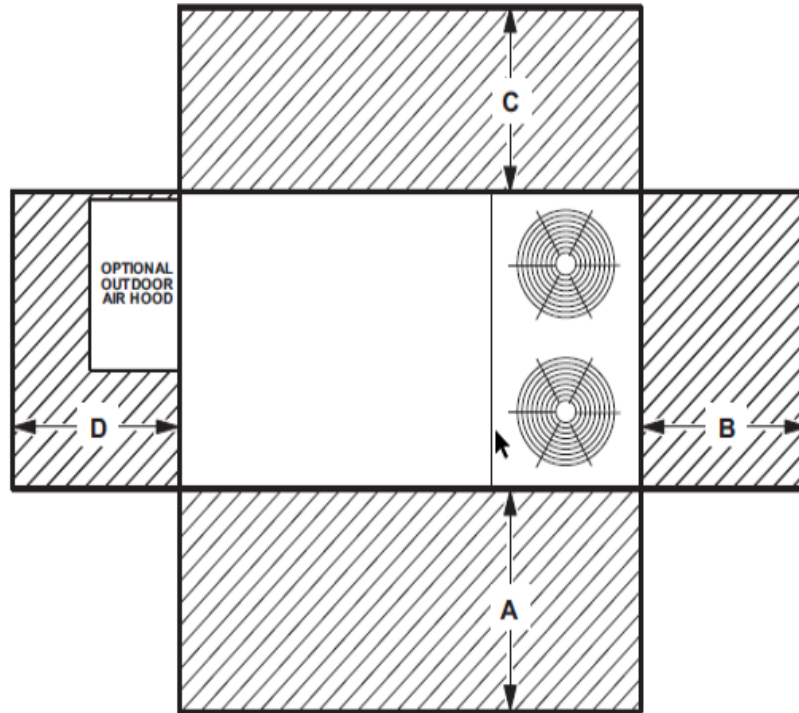

¹ Unit Clearance	A		B		C		D		Top Clearance
	in.	mm	in.	mm	in.	mm	in.	mm	
Service Clearance	60	1524	36	914	36	934	60	1524	Unobstructed
Clearance to Combustibles	36	914	1	25	1	25	1	25	
Minimum Operation Clearance	36	914	36	914	36	914	36	914	

NOTE - Entire perimeter of unit base requires support when elevated above the mounting surface.

¹ Service Clearance - Required for removal of serviceable parts.

Clearance to Combustibles - Required clearance to combustible material.

Minimum Operation Clearance - Required clearance for proper unit operation.



Lennox National Accounts Project Submittal

Tag: Miscellaneous Items

Miscellaneous Items

Tag	Catalog Number	Qty	Description
Curb Adapters RTU 5,6,7			
	COMSD	3	Curbs Plus Adapters # LX108LX6
Curb Adapter RTU 8			
	COMSD	1	Curbs Plus Adapter # LX296LX9
Wind Clips			
	COMSD	4	Clips (set of 10)