



SUBMITTAL SHEET

Edifice, LLC
NC4205 . - CMS Grier Elementary School

Project: NC4205 .
CMS Grier Elementary School
7515 The Plaza
Charlotte, NC
28215

Spec Section Num: 236426
Submittal: 236426.001
Revision: 1
Package:
Date: 5/4/2022 EDT

Submittal Title: Air Cooled Water Chillers Product Data
Submittal Detail:
Response Due By: 5/18/2022 EDT

Contractor:
Malachi Alexander
Edifice, Inc.

Contractor's Stamp

THIS REVIEW IS FOR GENERAL COMPLIANCE WITH THE DESIGN CONCEPT THE SUBCONTRACTOR / VENDOR IS RESPONSIBLE FOR DIMENSIONS TO BE CONFIRMED AND COORDINATED IN THE FIELD AND REMAINS RESPONSIBLE FOR VERIFICATION OF ALL QUANTITIES. EDIFICE IS NOT RESPONSIBLE FOR ANY DEVIATION FROM THE CONTRACT DOCUMENTS. DEVIATIONS AND / OR SUBSTITUTIONS MUST BE CLEARLY IDENTIFIED. APPROVAL OF ANY DEVIATIONS / SUBSTITUTIONS MUST BE MADE BY OWNER OR DESIGN TEAM.

Architect:
Bill Nord
Optima Engineering, pa

Architect's Stamp

SHOP DRAWING REVIEW

NO EXCEPTION TAKEN
 APPROVED AS NOTED
 REVISE AND RESUBMIT
 REJECTED



REVIEW IS FOR GENERAL COMPLIANCE WITH THE INTENT OF THE CONTRACT DOCUMENTS. MECHANICAL CONTRACTOR SHALL ASSUME RESPONSIBILITY FOR CORRECTNESS, DIMENSIONS, DETAILS, QUANTITIES AND ALL COST ASSOCIATED WITH SUBSTITUTED EQUIPMENT, INCLUDING MAINTENANCE ACCESS, CLEARANCES, BUILDING ALTERATIONS, REPLACEMENT OF OTHER SYSTEM COMPONENTS, ETC.

BY Bill Nord DATE 5/11/2022

Response:
Comment: In response to the seismic comment from previous submittal. Carrier do not provide any standard statements regarding seismic for our equipment. Seismic certifications can be achieved via ETO which significantly increases lead time and price for units.

see submittal for comments



SUBMITTAL

Project

CMS Hidden Valley, Grier, Newell

Date

April 27 2022

Mechanical Engineer

Optima Engineering

Mechanical Contractor

Superior Mechanical Systems Inc.

In accordance with Specification Section 236426
AIR COOLED WATER CHILLERS

Notes:

1. In response to the seismic comment from previous submittal. **Carrier** do not provide any standard statements regarding seismic for our equipment. Seismic certifications can be achieved via ETO which significantly increases lead time and price for units.

The seismic/vibration items will be in the vibration submittal package.

Table Of Contents

Project: CMS Hidden Valley, Grier, Newell
Prepared By: Paul Shelor

04/27/2022
03:51PM

CH-1	3
Unit Report.....	4
Certified Drawing.....	5
Field Wiring Diagram.....	6
Guide Specifications.....	7
Detailed Performance Report.....	18

CH-1

**Tag Cover Sheet
Unit Report
Certified Drawing
Wiring Diagram
Guide Specification
Detailed Performance Report**

Unit Report For CH-1

Project: CMS Hidden Valley, Grier, Newell
 Prepared By: Paul Shelor

04/27/2022
 03:51PM

Unit Information

Tag Name:..... **CH-1**
 Model Number:..... **30XV250**
 Condenser Type:..... **Air Cooled**
 Compressor Type:..... **VFD Screw**
 Nameplate Voltage:..... **460-3-60** V-Ph-Hz
 Quantity:..... **1**
 Manufacturing Source:..... **Charlotte, NC USA**
 Refrigerant:..... **R134A**
 Independent Refrigerant Circuits:..... **2**
 Capacity Control Steps:..... **0**
 Minimum Capacity:..... **15.0** %
 Shipping Weight:..... **15660** lb
 Operating Weight:..... **15958** lb
 Unit Length:..... **299** in
 Unit Width:..... **88** in
 Unit Height:..... **99** in

Accessories and Installed Options

Isolation Valve(s)
 Suction Line Insulation
 Control Transformer
 Non-Fused Disconnect
 EMM (includes GFI Convenience Outlet)
 Flooded Evaporator, 2 pass, w/ Heater
 Variable Speed Condenser Fans
 High SCCR 65 kA Current Rating
 None
 Full Hail Guard
 Low Ambient Head Pressure Control
 Standard Tier

Chiller Warranty Information (Note: for US & Canada only)

First Year - Parts Only (Standard)
 Start up, First Unit
 Complete Unit Year 2-10.5 Parts Parts & Labor

Ordering Information

Part Number	Description	Quantity
30XV-2506S4006DD3	Packaged Chiller	1
	Base Unit	
	Isolation Valve(s)	
	Suction Line Insulation	
	Control Transformer	
	Non-Fused Disconnect	
	EMM (includes GFI Convenience Outlet)	
	Flooded Evaporator, 2 pass, w/ Heater	
	Variable Speed Condenser Fans	
	High SCCR 65 kA Current Rating	
	None	
	Full Hail Guard	

Part Load Efficiency rating does not match scheduled value.
Coordinate power requirements for evaporator heater and heat tracing with Electrical Drawings.
Coordinate Controls functions with BAS Contractor, including built in Lead/Lag compressor control and Open Protocol
Verify Full Hail Guard complies with Architectural Louvers Panels accessory
Coordinate equipment weight with concrete pad.
Verify Phase Loss Protection provided
Verify neoprene isolators provided
Specifications call for operating range down to 10% of design capacity.
Verify protective coating for insulation exposed to weather

JOB NAME:
-

BUYER:
-

SALES ENG.:
-

MODEL NO.:
-

JOB NO.:
-

P.O. NO.:
-

PREPARED BY:
-

ELECTRICAL CHARACTERISTICS:
-

JOBSITE LOCATION:
-

SALES OFFICE:
-

REFRIGERANT NO.:
-

NOTES:
-

COND: 1, 1A-1F
COOLER: 2, 2A-2G
MACHINE ASSEMBLY
NON CONTROL PANEL
END VIEW

DATE: -
REVISION: -

THIS DOCUMENT IS THE PROPERTY OF CARRIER CORP. AND IS DELIVERED UPON THE EXPRESS CONDITION THAT THE CONTENTS WILL NOT BE DISCLOSED OR USED WITHOUT CARRIER CORP. WRITTEN CONSENT.

SUBMISSION OF THESE DWG'S. OR DOCUMENTS DOES NOT CONSTITUTE PART PERFORMANCE OR ACCEPTANCE OF CONTRACT.

CARRIER DWG # 026000 600-1
REV. 01 OF 01
DATE: 7-18-2020
SUPERSEDES DWG. DA LD:

30XV
SHT 05 OF 07

UNIT	A	B	C
250 STD	22.17[563.1]	10.99[279.1]	6"
275 STD	23.28[591.3]	11.87[301.5]	8"

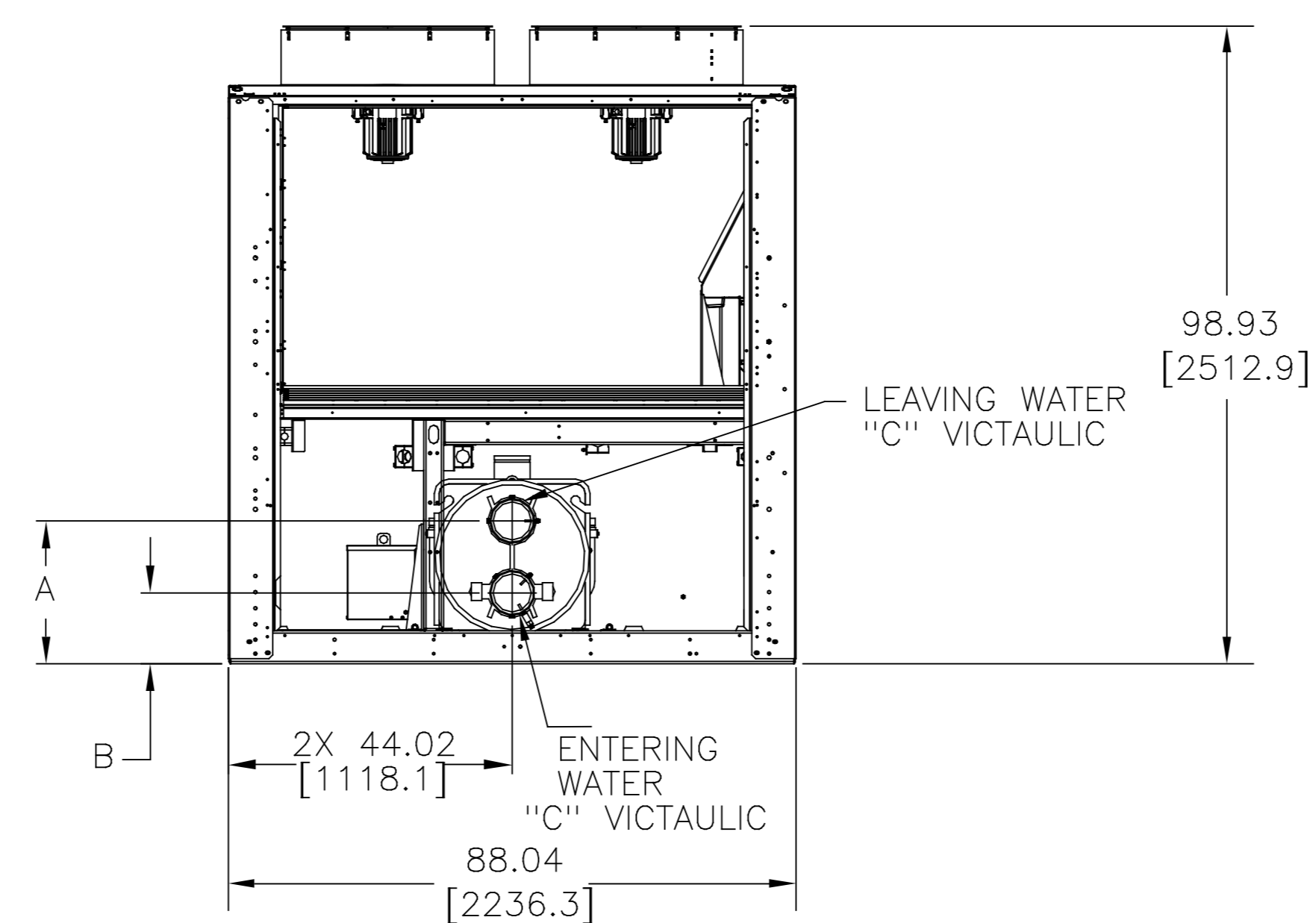

FLOODED EVAPORATOR, 2 PASS

30XV NON CONTROL PANEL END VIEW

JOB NAME:
-

BUYER:
-

SALES ENG.:
-

MODEL NO.:
-

JOB NO.:
-

P.O. NO.:
-

PREPARED BY:
-

ELECTRICAL CHARACTERISTICS:
-

JOB SITE LOCATION:
-

SALES OFFICE:
-

REFRIGERANT NO.:
-

NOTES:
-

COND: 1, 1A-1F
COOLER: 2, 2A-2G
MACHINE ASSEMBLY
CONTROL PANEL END VIEW

DATE: -

REVISION: -

THIS DOCUMENT IS THE PROPERTY OF CARRIER CORP. AND IS DELIVERED UPON THE EXPRESS CONDITION THAT THE CONTENTS WILL NOT BE DISCLOSED OR USED WITHOUT CARRIER CORP. WRITTEN CONSENT.

SUBMISSION OF THESE DWG'S. OR DOCUMENTS DOES NOT CONSTITUTE PART PERFORMANCE OR ACCEPTANCE OF CONTRACT.

CARRIER DWG # 036000 600-0
REV. - SHEET 01 OF 01
DATE: 7-13-2020
SUPERSEDES DWG. DA LD:
-

30XV

SHT 04 OF 07

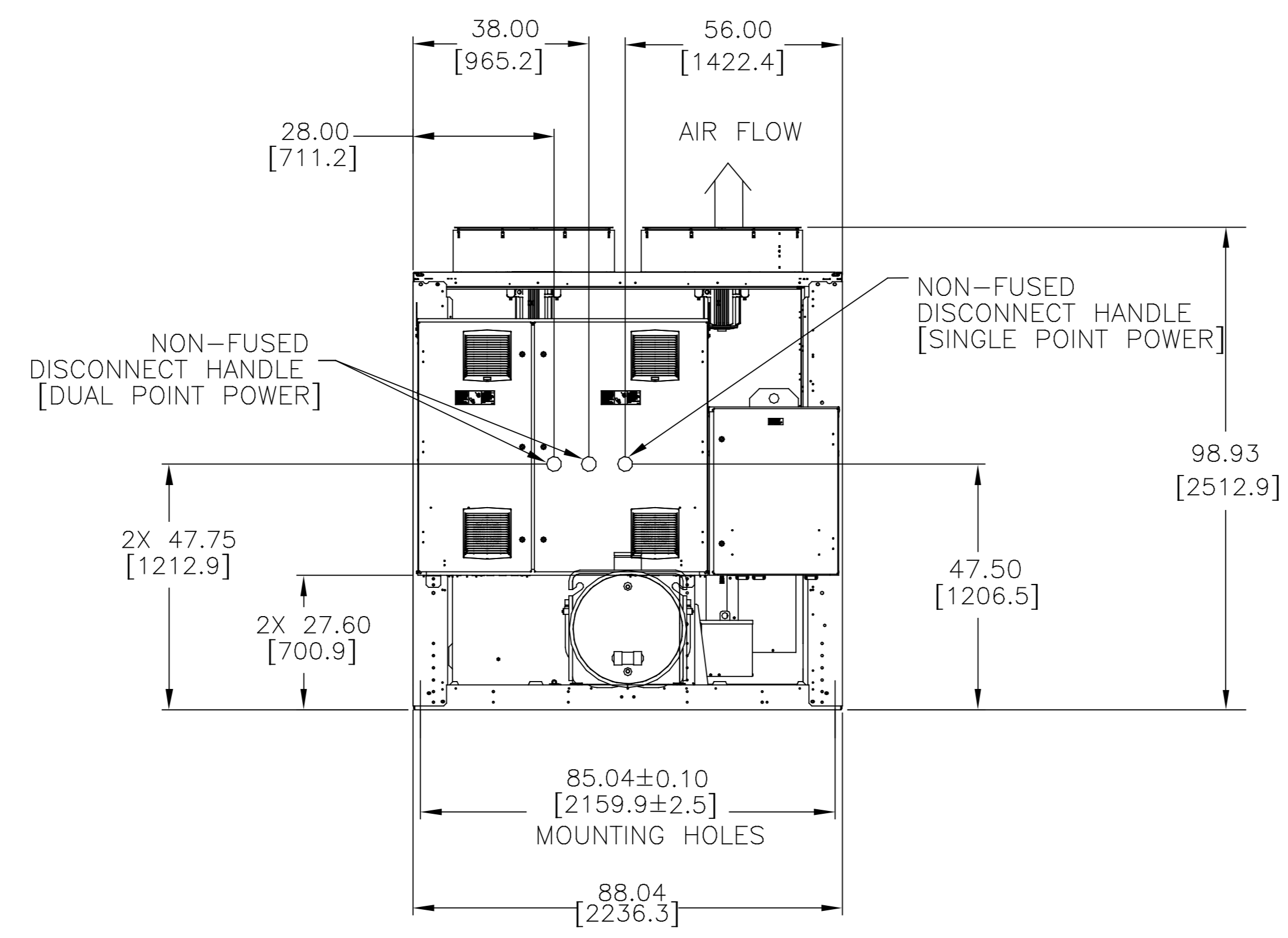

30XV CONTROL PANEL END VIEW

JOB NAME:
-

BUYER:
-

SALES ENG.:

MODEL NO.:

JOB NO.:

P.O. NO.:

PREPARED BY:

ELECTRICAL CHARACTERISTICS:

JOB SITE LOCATION:

SALES OFFICE:

REFRIGERANT NO.:

NOTES:

COND: 1, 1A-1F
COOLER: 2, 2A-2G
MACHINE ASSEMBLY
FRONT VIEW

DATE: -
REVISION: -

THIS DOCUMENT IS THE PROPERTY OF CARRIER CORP. AND IS DELIVERED UPON THE EXPRESS CONDITION THAT THE CONTENTS WILL NOT BE DISCLOSED OR USED WITHOUT CARRIER CORP. WRITTEN CONSENT.
SUBMISSION OF THESE DWG'S OR DOCUMENTS DOES NOT CONSTITUTE PART PERFORMANCE OR ACCEPTANCE OF CONTRACT.

CARRIER DWG # 016000 600-1
REV. - SHIT 01 OF 01
DATE: 7-18-2020
SUPERSEDES DWG. DA LD:

30XV

SHT 01 OF 07

UNIT	CENTER OF GRAVITY									
	CGx				CGy		CGz			
	MCHX		AL/CU		CU/CU					
	INCH	MM	INCH	MM	INCH	MM	INCH	MM	INCH	MM
30XV-250 STD	137.7	3497	137.9	3502	138.2	3510	45.4	1152	34.2	869
30XV-275 STD	138.7	3522	139.2	3535	139.0	3531	45.4	1154	34.0	864

⊕ SYMBOL DENOTES CG

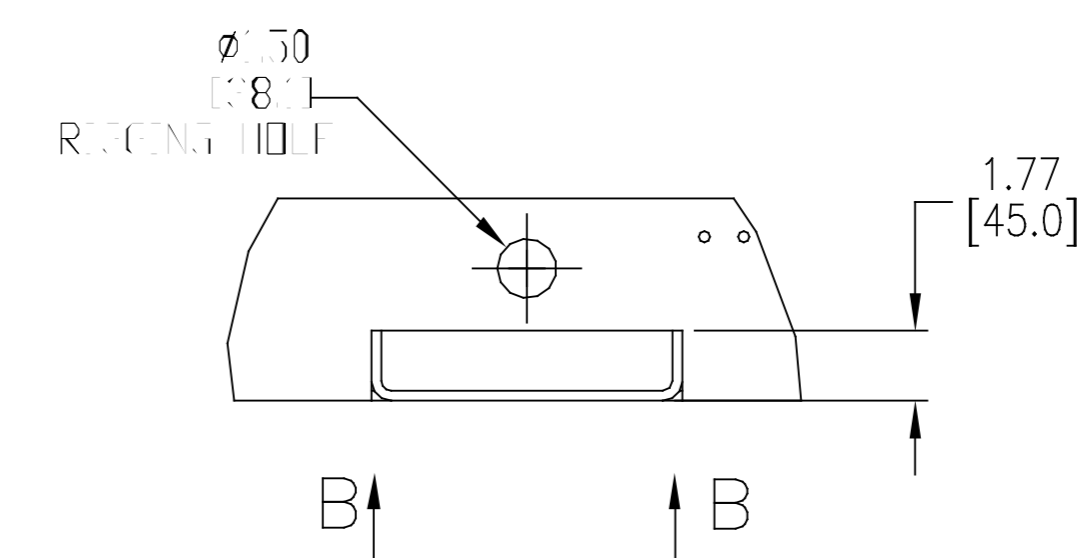

DETAIL A
AT (10) PLCS

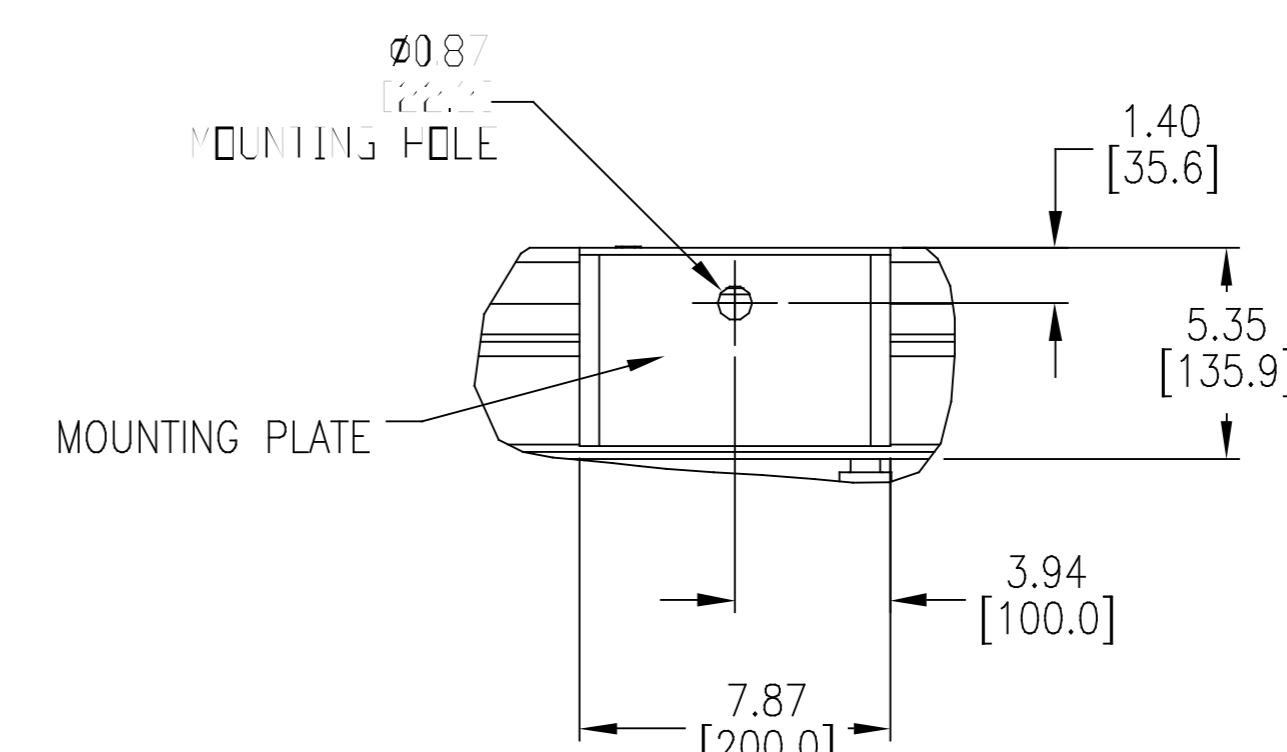

View B-B
30XV MOUNTING PLATE

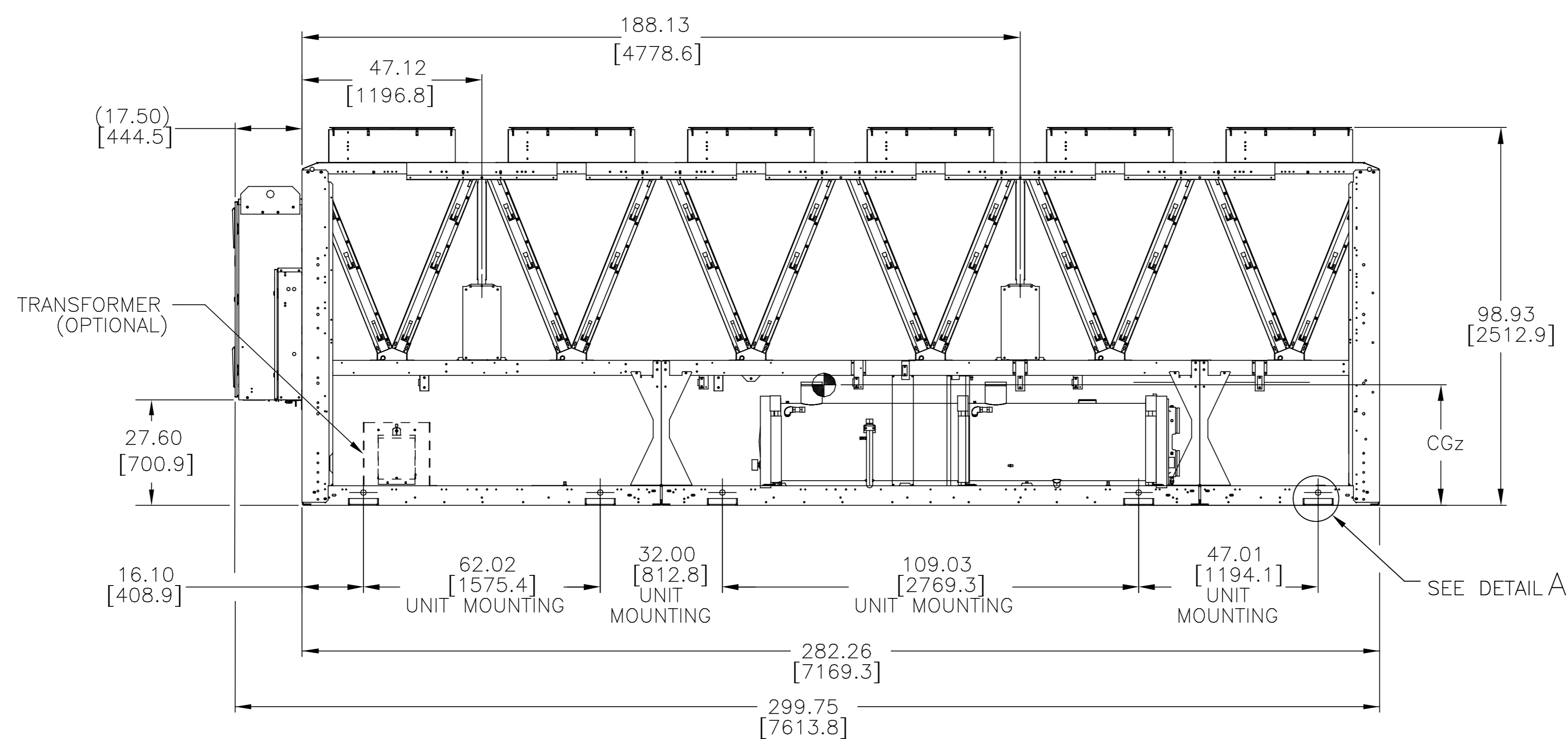

30XV FRONT VIEW
(CONDENSER HEADER END)

PREFERRED MAIN POWER SUPPLY CONDUIT ROUTING.
GENERIC LOCATION - DO NOT PLACE CONDUIT IN FRONT OF CONTROL PANEL.
ACCESS FOR SERVICE IS REQUIRED.

UNIT	CENTER OF GRAVITY									
	MCHX		AL/CU		CU/CU		CGy		CGz	
	INCH	MM	INCH	MM	INCH	MM	INCH	MM	INCH	MM
30XV-250 STD	137.7	3497	137.9	3502	138.2	3510	45.4	1152	34.2	869
30XV-275 STD	138.7	3522	139.2	3535	139.0	3531	45.4	1154	34.0	864

⊕ SYMBOL DENOTES CG

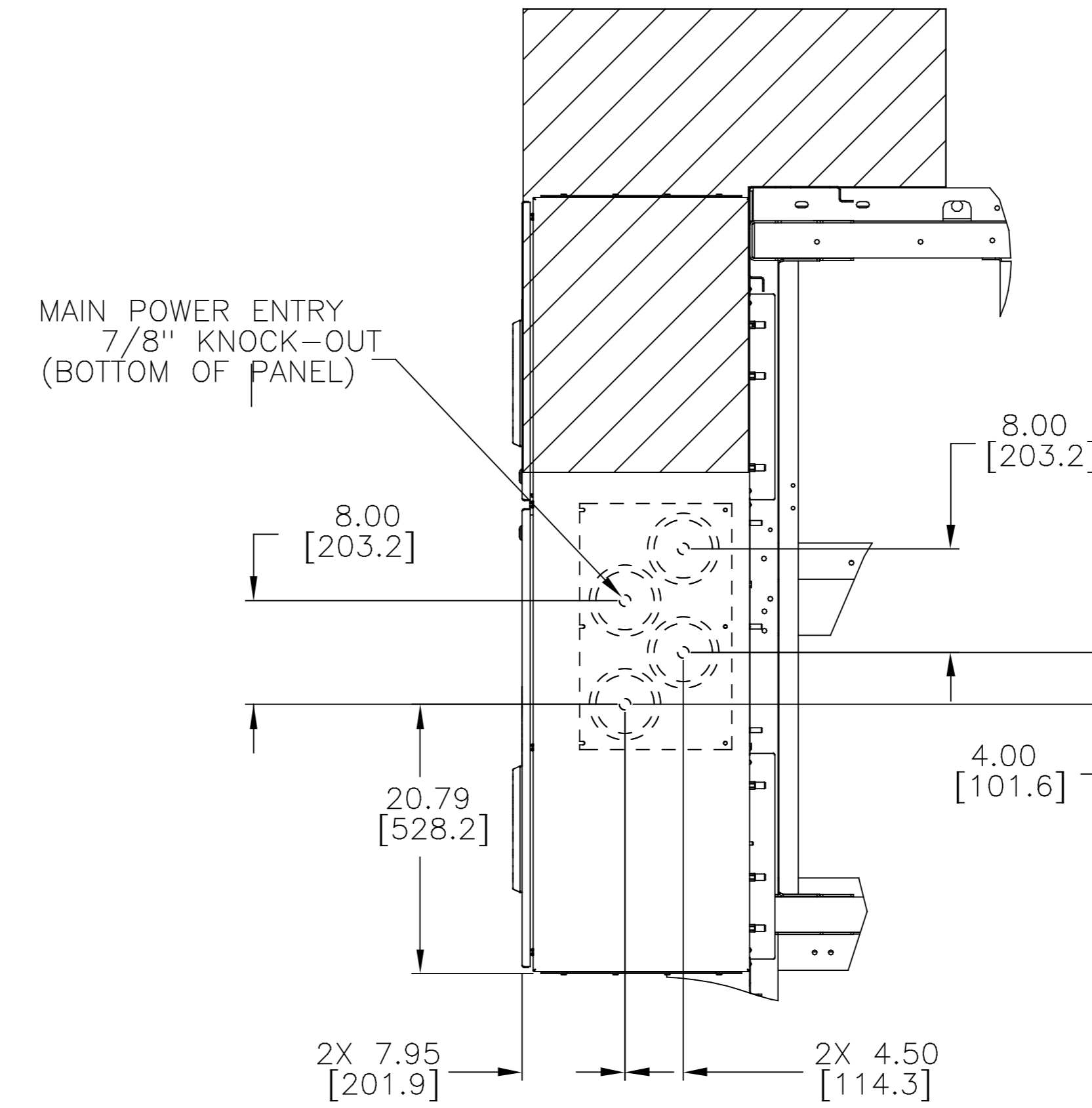

DETAIL C
(TOP VIEW- KNOCK OUTS ON BOTTOM OF CONTROL BOX)

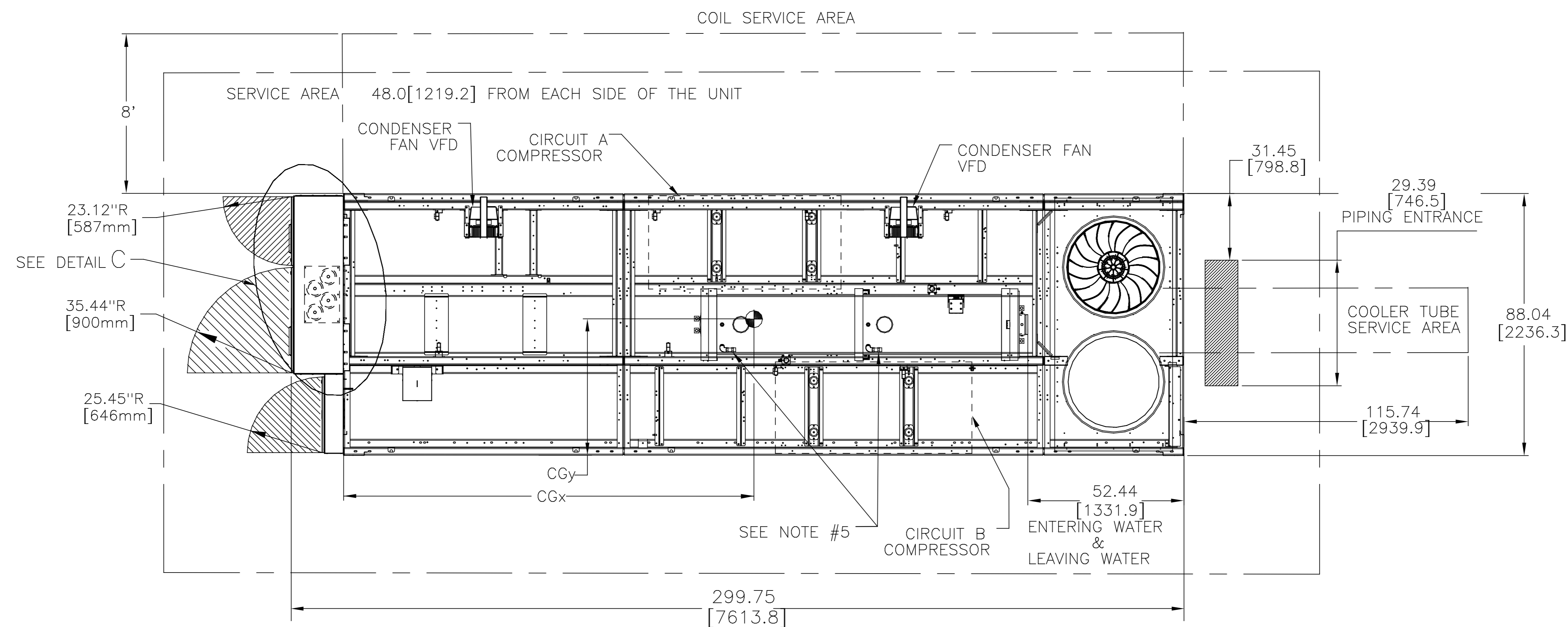

30XV PLAN VIEW

JOB NAME: -

BUYER: -

SALES ENG.: -

MODEL NO.: -

JOB NO.: -

P.O. NO.: -

PREPARED BY: -

ELECTRICAL CHARACTERISTICS: -

JOB SITE LOCATION: -

SALES OFFICE: -

REFRIGERANT NO.: -

NOTES:

COND: 1, 1A-1F
COOLER: 2, 2A-2G
MACHINE ASSEMBLY
PLAN VIEW

DATE: -

REVISION: -

THIS DOCUMENT IS THE PROPERTY OF CARRIER CORP. AND IS DELIVERED UPON THE EXPRESS CONDITION THAT THE CONTENTS WILL NOT BE DISCLOSED OR USED WITHOUT CARRIER CORP. WRITTEN CONSENT.

SUBMISSION OF THESE DWG'S. OR DOCUMENTS DOES NOT CONSTITUTE PART PERFORMANCE OR ACCEPTANCE OF CONTRACT.

CARRIER DWG # 02X6000 600-P
REV. - SH 01 OF 01
DATE: 7-18-2020
SUPERSEDES DWG. DA LD: -

30XV
SHT 02 OF 07

JOB NAME:
-

BUYER:
-

SALES ENG.:
-

MODEL NO.:
-

JOB NO.:
-

P.O. NO.:
-

PREPARED BY:
-

ELECTRICAL CHARACTERISTICS:
-

JOBSITE LOCATION:
-

SALES OFFICE:
-

REFRIGERANT NO.:
-

NOTES:
-

COND: 1, 1A-1F
COOLER: 2, 2A-2G
MACHINE ASSEMBLY
REAR VIEW

DATE: -

REVISION: -

THIS DOCUMENT IS THE PROPERTY OF CARRIER CORP. AND IS DELIVERED UPON THE EXPRESS CONDITION THAT THE CONTENTS WILL NOT BE DISCLOSED OR USED WITHOUT CARRIER CORP. WRITTEN CONSENT.

SUBMISSION OF THESE DWG'S. OR DOCUMENTS DOES NOT CONSTITUTE PART PERFORMANCE OR ACCEPTANCE OF CONTRACT.

CARRIER DWG # 03XV6000 600-R
 REV. 03 OF 07
 DATE: 7-18-2020
 SUPERSEDES DWG. DA LD:

30XV

SHT 03 OF 07

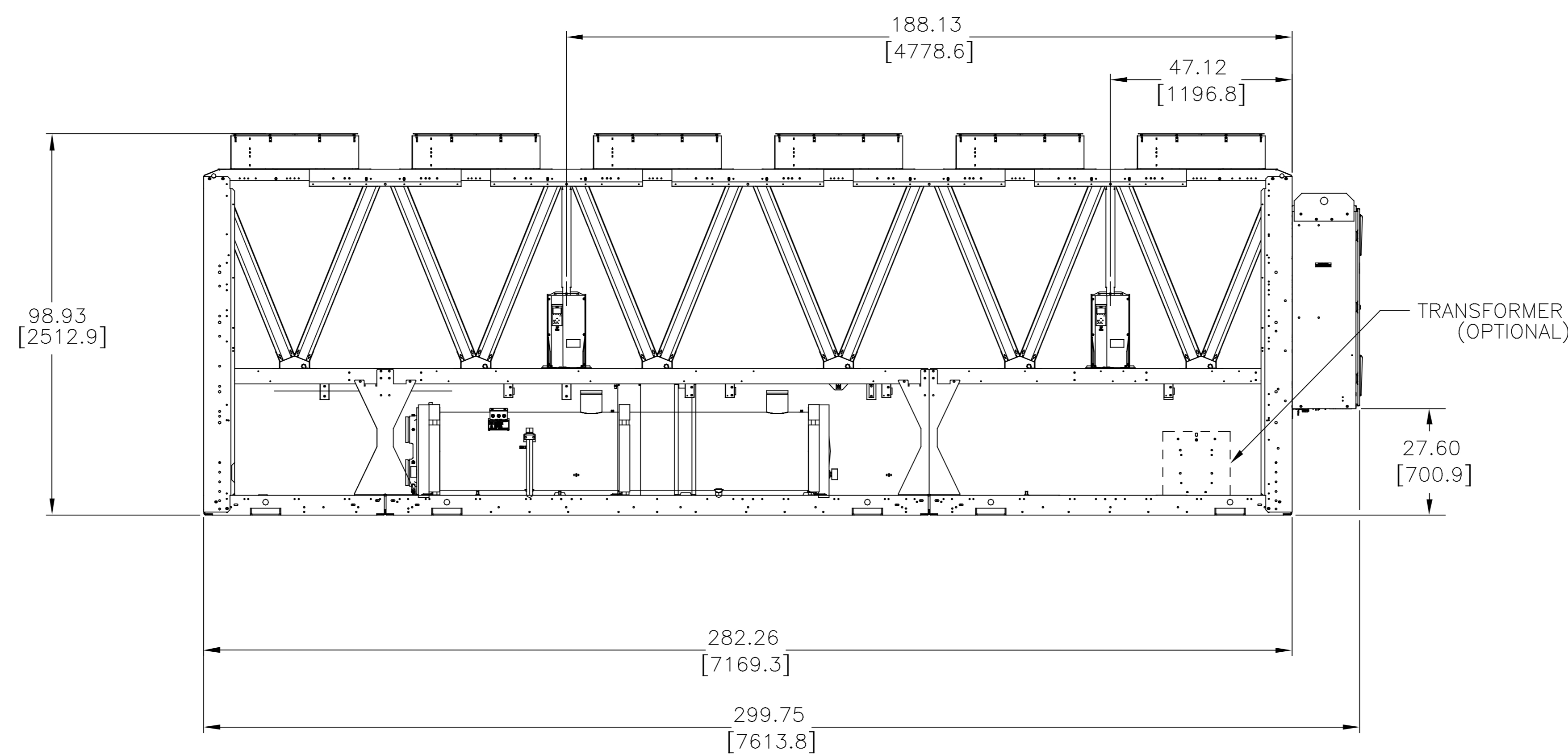

30XV REAR VIEW

JOB NAME:
-

BUYER:
-

SALES ENG.:
-

MODEL NO.:
-

JOB NO.:
-

P.O. NO.:
-

PREPARED BY:
-

ELECTRICAL CHARACTERISTICS:
-

JOBSITE LOCATION:
-

SALES OFFICE:
-

REFRIGERANT NO.:
-

NOTES:
-

COND: 1, 1A-1F
COOLER: 2, 2A-2G
MACHINE ASSEMBLY
ELE. DROP POINT VIEW

DATE: -
REVISION: -

THIS DOCUMENT IS THE PROPERTY OF CARRIER CORP. AND IS DELIVERED UPON THE EXPRESS CONDITION THAT THE CONTENTS WILL NOT BE DISCLOSED OR USED WITHOUT CARRIER CORP. WRITTEN CONSENT.

SUBMISSION OF THESE DWG'S. OR DOCUMENTS DOES NOT CONSTITUTE PART PERFORMANCE OR ACCEPTANCE OF CONTRACT.

CARRIER DWG # 006000 600-03
REV. 01 SH 01 OF 01
DATE: 7-15-2020
SUPERSEDES DWG. DATA ID:
-

30XV
SHT 06 OF 07

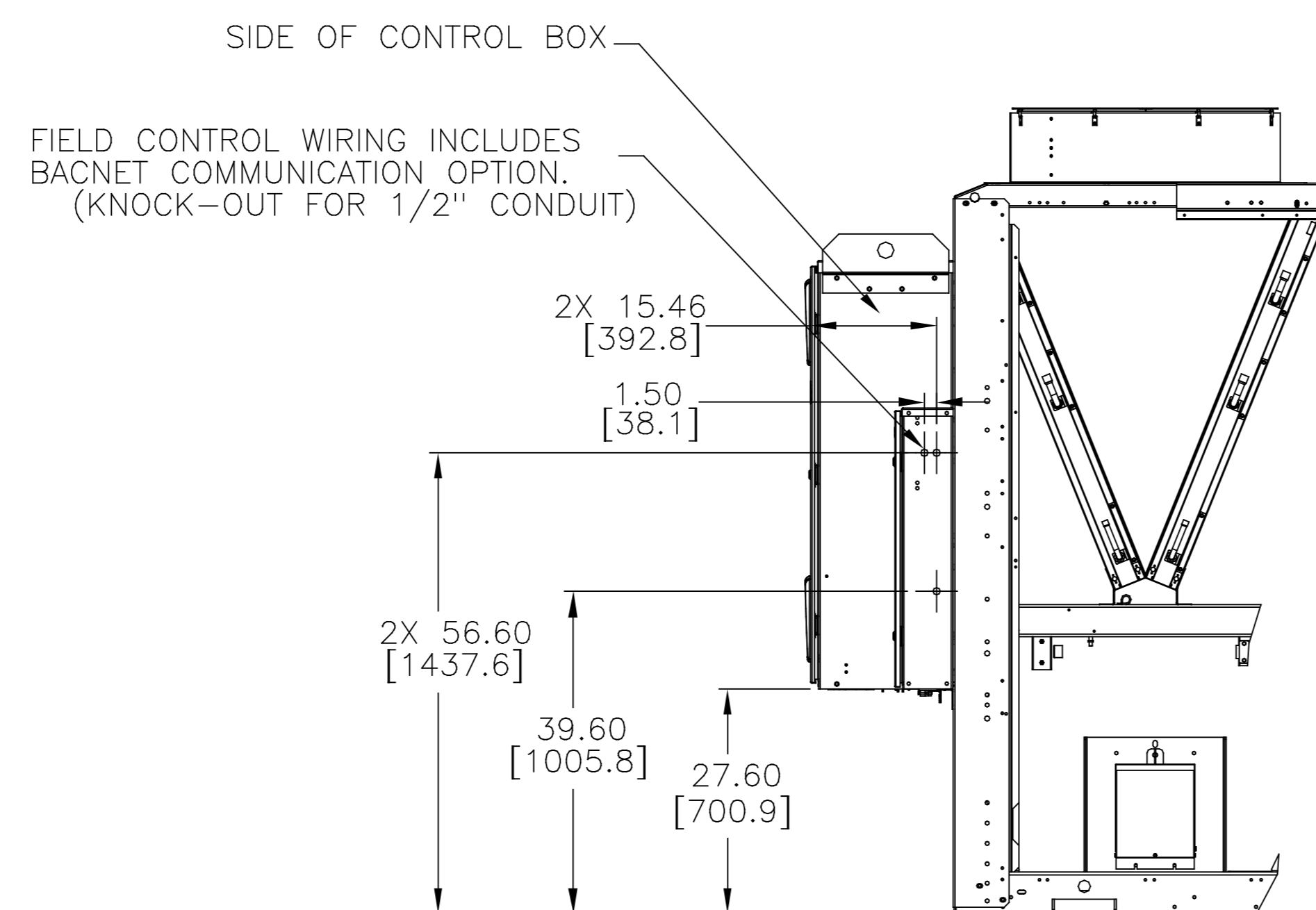

30XV SURFACE CONTACT OR ELECTRICAL DROP POINTS

NOTES:

- FACTORY WIRING IS IN ACCORDANCE WITH UL 1995 STANDARDS. FIELD MODIFICATIONS OR ADDITIONS MUST BE IN COMPLIANCE WITH ALL APPLICABLE CODES.
- WIRING FOR MAIN FIELD SUPPLY MUST BE RATED 75C MINIMUM. USE COPPER FOR ALL UNITS.

3ØV UNIT SIZE	VOLTAGE	DISCONNECT OPTION	NO. OF CONDUCTORS PER PHASE	LUG RANGE
SINGLE POINT POWER				
140-200	208/230V	NO	4	#2AWG - 750 KCMIL
140-325	380-575V	NO	2	#2AWG - 600 KCMIL
140-200	380-575V	NFD	2	2/0 - 500 KCMIL
225-325	380-440V	NFD	4	4/0 - 500 KCMIL
225-325	460-575V	NFD	3 or (2)	3/0 - 400 KCMIL OR (500KCMIL-750KCMIL)
350-500	380-440V	NO	6	#2AWG - 750 KCMIL
350-500	460-575V	NO	4	#2AWG - 750 KCMIL
350-500	380-440V	NFD	6	#2AWG - 600 KCMIL
350-500	460-575V	NFD	4	4/0 - 500 KCMIL
DUAL POINT POWER				
140-200	208/230V	NO	3	3/0 - 400 KCMIL
140-200	380-575V	NO	1 OR (2)	2/0-500 KCMIL OR (2/0-250 KCMIL)
225-325	380-575V	NO	2	#2AWG - 500 KCMIL
140-200	380-575V	NFD	1 OR (2)	2/0-500 KCMIL OR (2/0-250 KCMIL)
225-325	380-575V	NFD	2	#2AWG - 500 KCMIL
350-500	380-440V	NO	4	#2AWG - 750 KCMIL
350-500	460-575V	NO	2	#2AWG - 600 KCMIL
350-500	380-575V (HSCCR)	NO	3	3/0 - 400 KCMIL

LEGEND:

- A - ALARM
- PMP - CHILLED WATER PUMP
- EMM - ENERGY MANAGEMENT
- TB - TERMINAL BLOCK
- MLV - MINIMUM LOAD VALVE
- NEC - NATIONAL ELECTRIC CODE
- HSCCR - HIGH SHORT CIRCUIT CURRENT RATING
- SCCR - SHORT CIRCUIT CURRENT RATING

- TERMINALS 9 AND 10 OF TB5 ARE FOR FIELD EXTERNAL CONNECTIONS FOR REMOTE ON-OFF. THE CONTACTS MUST BE RATED FOR DRY CIRCUIT APPLICATION CAPABLE OF HANDLING A 24VAC LOAD UP TO 50 MA.
- TERMINALS 11 AND 23 OF TB5 ARE FOR CONTROL OF CHILLED WATER PUMP 1 (PMP 1) STARTER. TERMINALS 15 AND 22 OF TB5 ARE FOR CONTROL OF CHILLED WATER PUMP 2 (PMP 2) STARTER. THE MAXIMUM LOAD ALLOWED FOR THE CHILLED WATER PUMP RELAY IS 5 VA SEALED, 10 VA INRUSH AT 24 V. FIELD POWER SUPPLY IS NOT REQUIRED.
- TERMINALS 12 AND 21 OF TB5 ARE FOR A ALARM RELAY. THE MAXIMUM LOAD ALLOWED FOR THE ALARM RELAY IS 10 VA SEALED, 25 VA INRUSH AT 24V. FIELD POWER SUPPLY IS NOT REQUIRED.
- MAKE APPROPRIATE CONNECTIONS TO TB6 AS SHOWN FOR ENERGY MANAGEMENT BOARD OPTIONS. THE CONTACTS FOR OCCUPANCY OVERRIDE, DEMAND LIMIT AND ICE DONE OPTIONS MUST BE RATED FOR DRY CIRCUIT APPLICATION CAPABLE OF HANDLING A 24VAC LOAD UP TO 50 MA.
- TERMINAL BLOCKS, TB5 & TB6 ARE LOCATED IN THE LOW VOLTAGE SECTION OF POWERBOX FOR ALL UNITS. REFER TO CERTIFIED DIMENSIONAL DRAWING FOR EACH UNIT TO GET THE EXACT LOCATIONS.
- REFER TO CERTIFIED DIMENSIONAL DRAWINGS FOR EXACT LOCATIONS OF THE MAIN POWER AND CONTROL POWER ENTRANCE LOCATIONS.
- TERMINALS 18 & 26 OF TB6 ARE FOR ALERT RELAY AND TERMINALS 20 & 26 OF TB6 ARE FOR SHUTDOWN RELAY. THE MAXIMUM LOAD ALLOWED FOR THE ALERT AND SHUTDOWN RELAY IS 10 VA SEALED, 25 VA INRUSH AT 24V. FIELD POWER SUPPLY IS NOT REQUIRED.

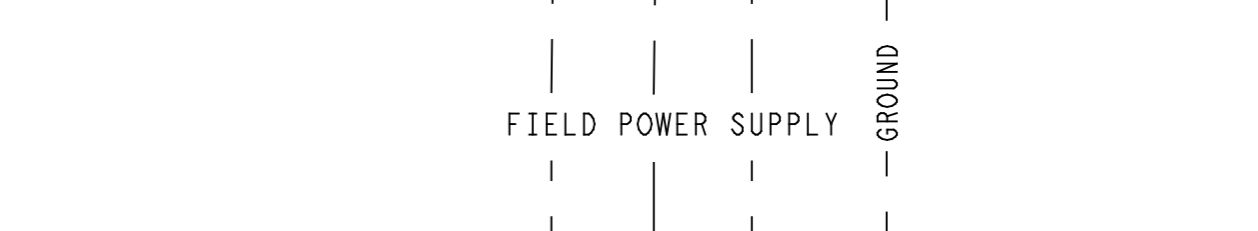
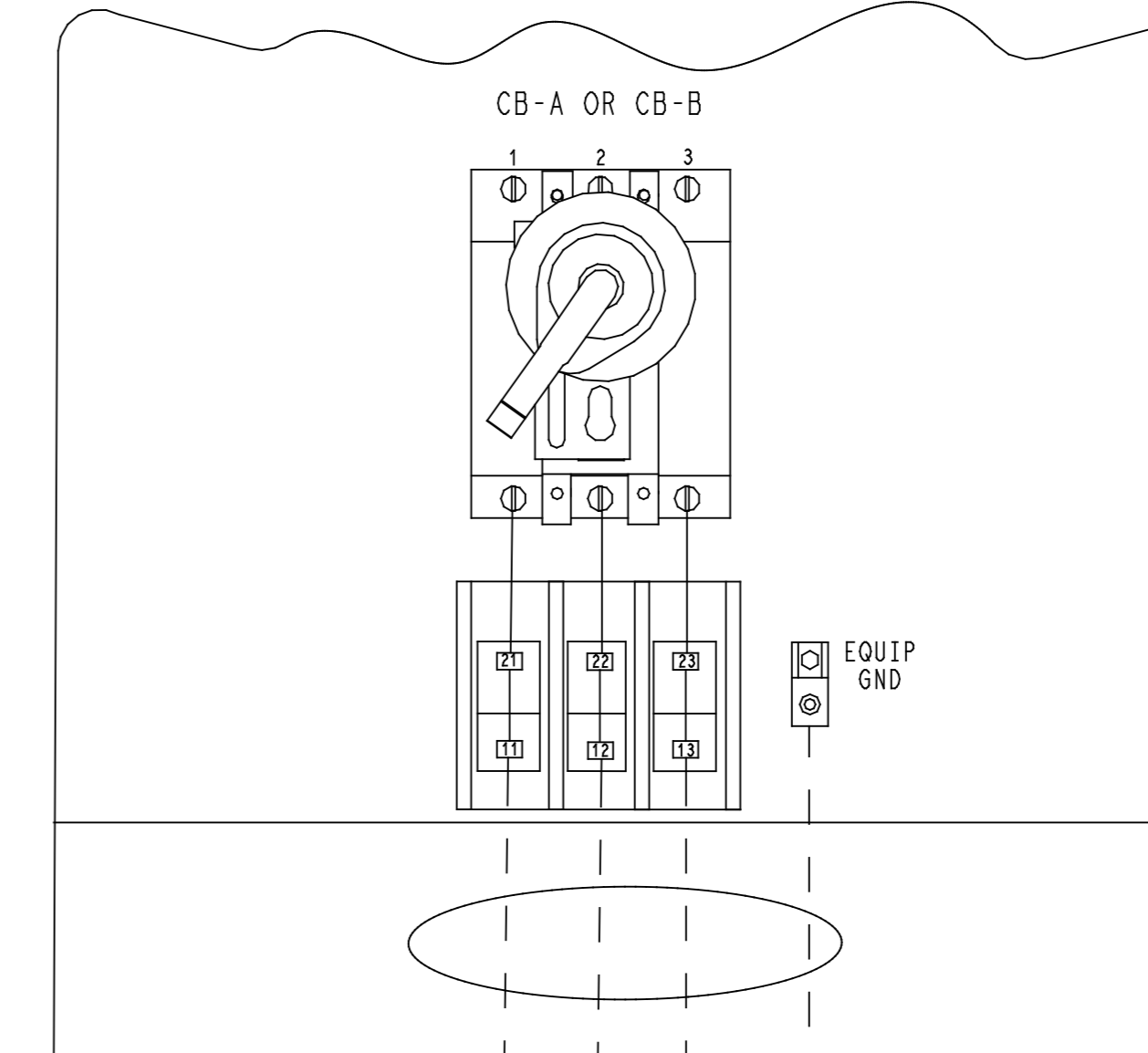
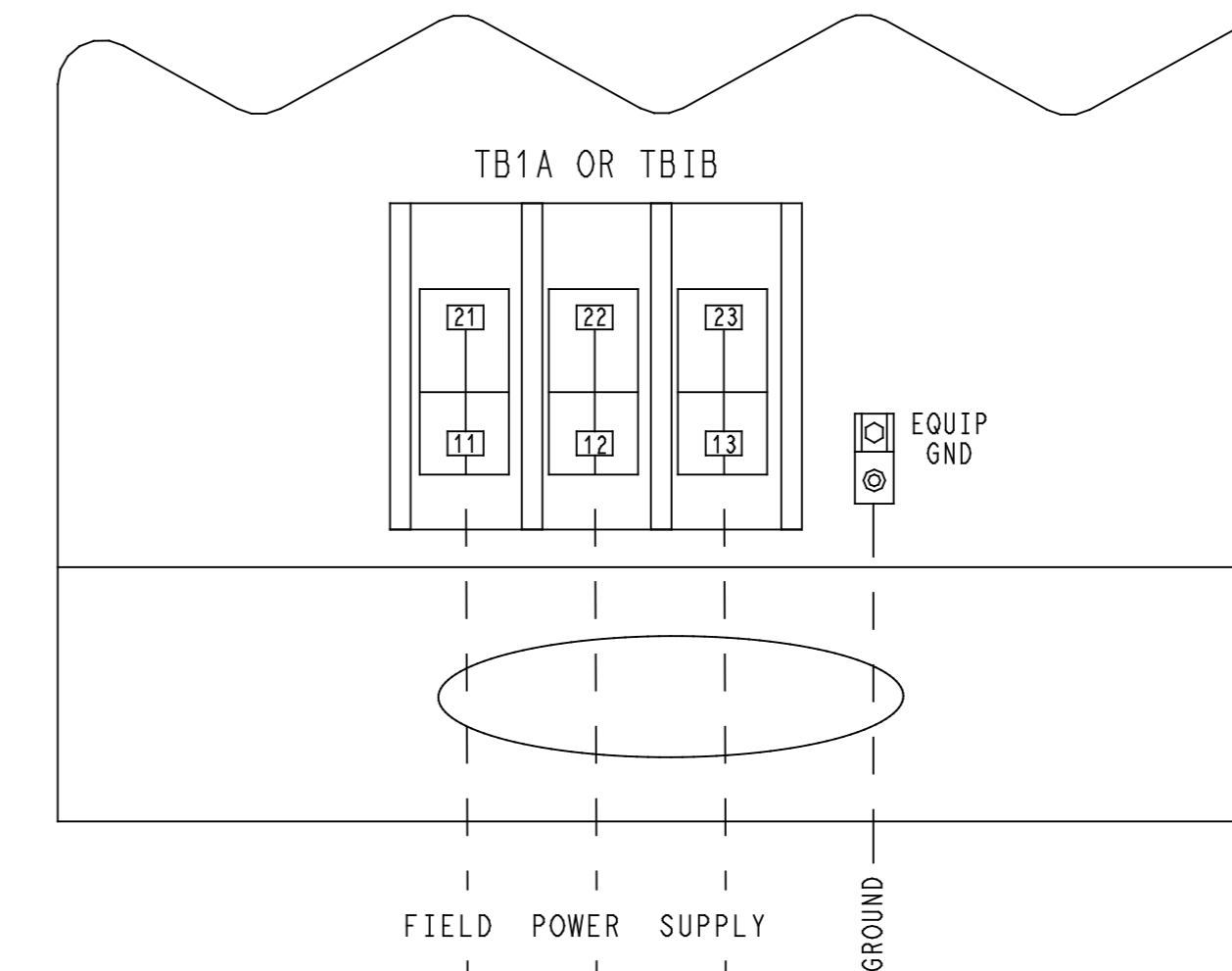
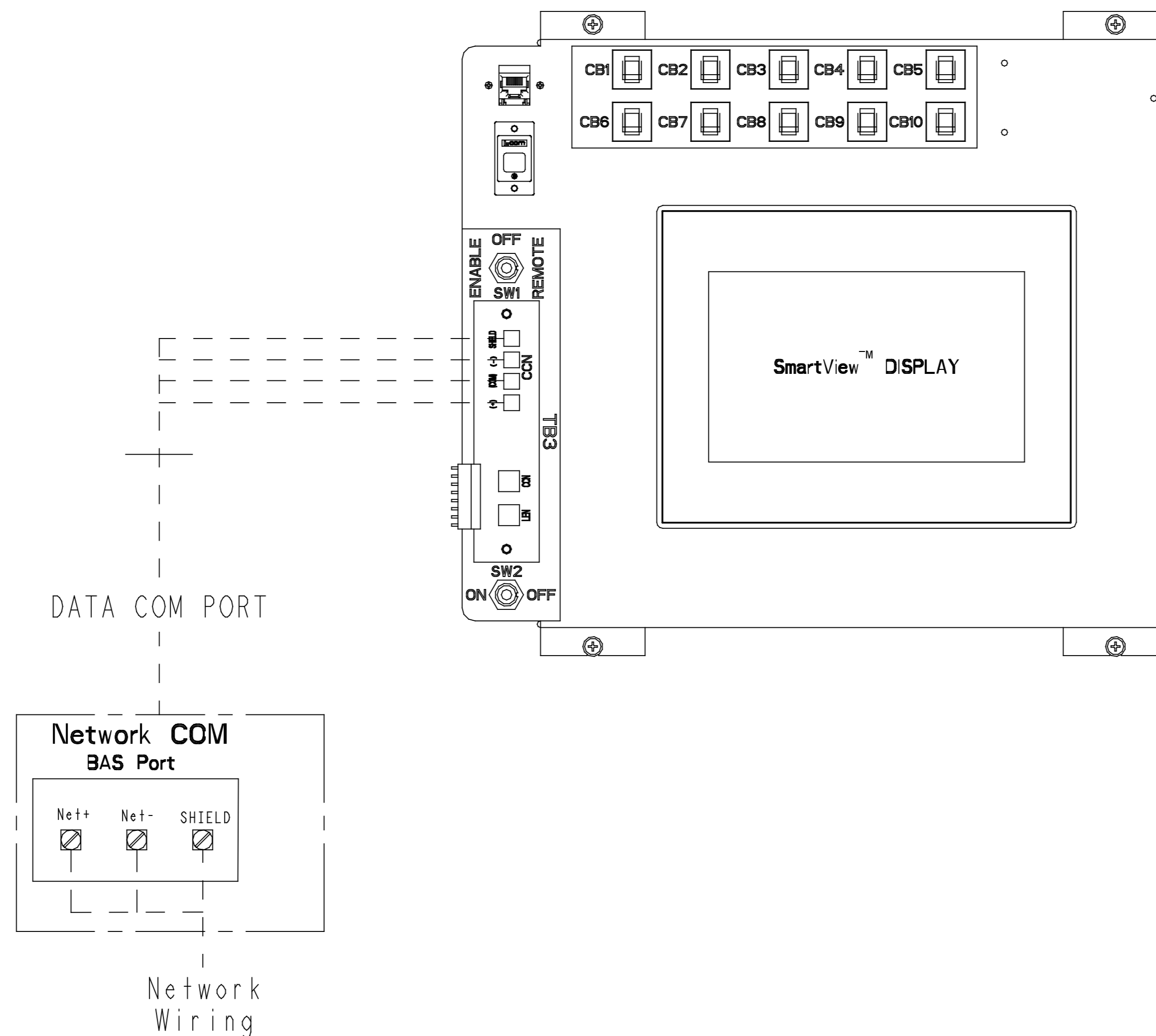

NON-FUSED DISCONNECT

JOB NAME: _____

BUYER: _____

SALES OFFICE: _____

MODEL NO: _____

JOB NO: _____

P.O. NO: _____

PREPARED BY: _____

FIELD WIRING CHARACTERISTICS: _____

JOB SITE LOCATION: _____

SALES OFFICE: _____

REFERENCE NO: _____

NOTES: _____

COND: 1, 2A-1F
COOLER: 2, 2A-2C
FIELD WIRING DRAWING: F-W-
DATE: _____

REVISION: ---

THIS DOCUMENT IS THE PROPERTY OF CARRIER CORP AND IS DELIVERED UPON THE EXPRESS CONDITION THAT THE CONTENTS WILL NOT BE REPRODUCED OR USED WITHOUT CARRIER CORP WRITTEN CONSENT.

SUBMISSION OF THESE DWGS OR DOCUMENTS DOES NOT CONSTITUTE PARTIAL OR FULL ACCEPTANCE OF CONTRACT.

CARRIER DWG #02X60002800-11W
REV: 01 OF 01
DATE: 7-9-2020
SUPERSEDES DWG. DATE: _____

30XV
SHEET 01 OF 03

JOB NAME:
-

BUYER:
-

CALEO ENG:

MODEL NO:
-

JOB NO:
-

P.O. NO:

PREPARED BY:
-

FIELD/RTCA CHARACTERISTICS:
-

JOB SITE LOCATION:

CALEO OFFICE:

REFERENTIAL NO:
-

NOTES:

COND: 1, 2A-1F
COOLER: 2, 2A-2C
FIELD WIRING DRAWING
#W-2

DATE: -

REVISION: ---

THIS DOCUMENT IS THE PROPERTY OF CARRIER CORP AND IS DELIVERED TO YOU FOR EXPRESS CONDITION THAT THE CONTENTS WILL NOT BE REPRODUCED OR USED WITHOUT CARRIER CORP WRITTEN CONSENT.

SUBMISSION OF THESE DWGS OR DOCUMENTS DOES NOT CONSTITUTE PART PER OR FAULT OR ACCEPTANCE OF CONTRACT.

CARRIER DWG #02X6000-800-01/2
REV. 01 OF 01
DATE: 7-9-2020
SUPERSEDES DWG. DATE:

30X

SHT 02 OF 03

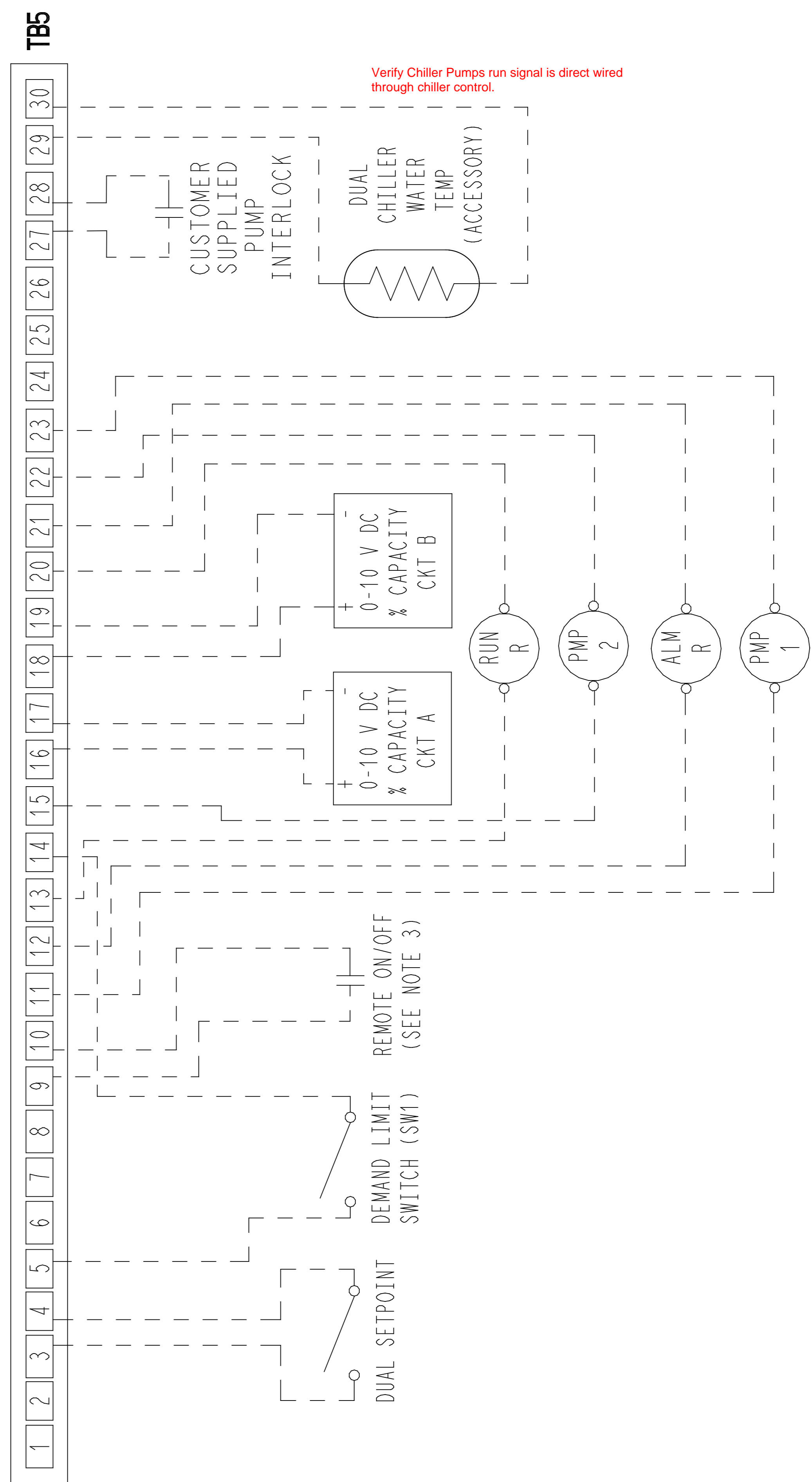
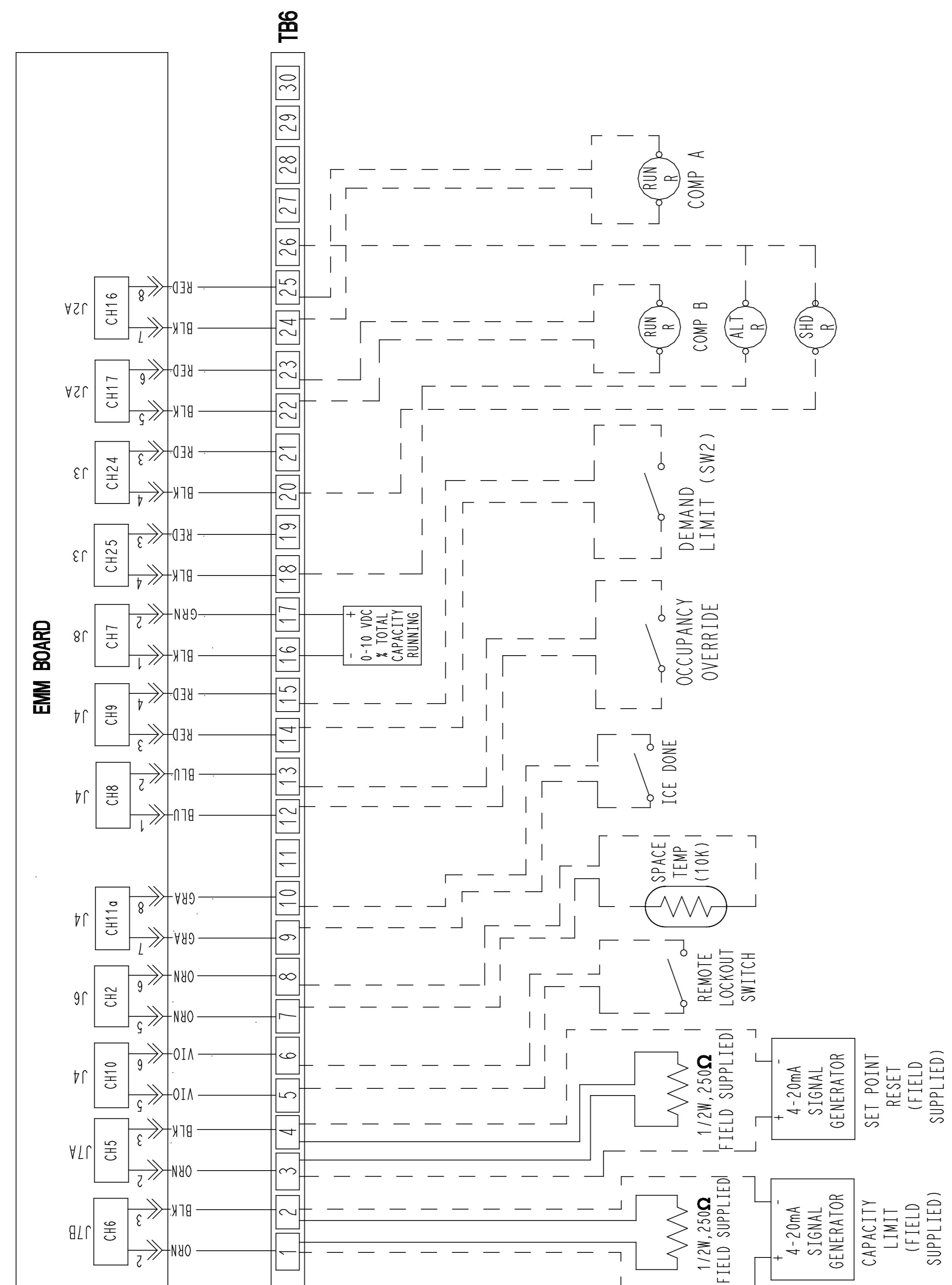

Verify Chiller Pumps run signal is direct wired through chiller control.

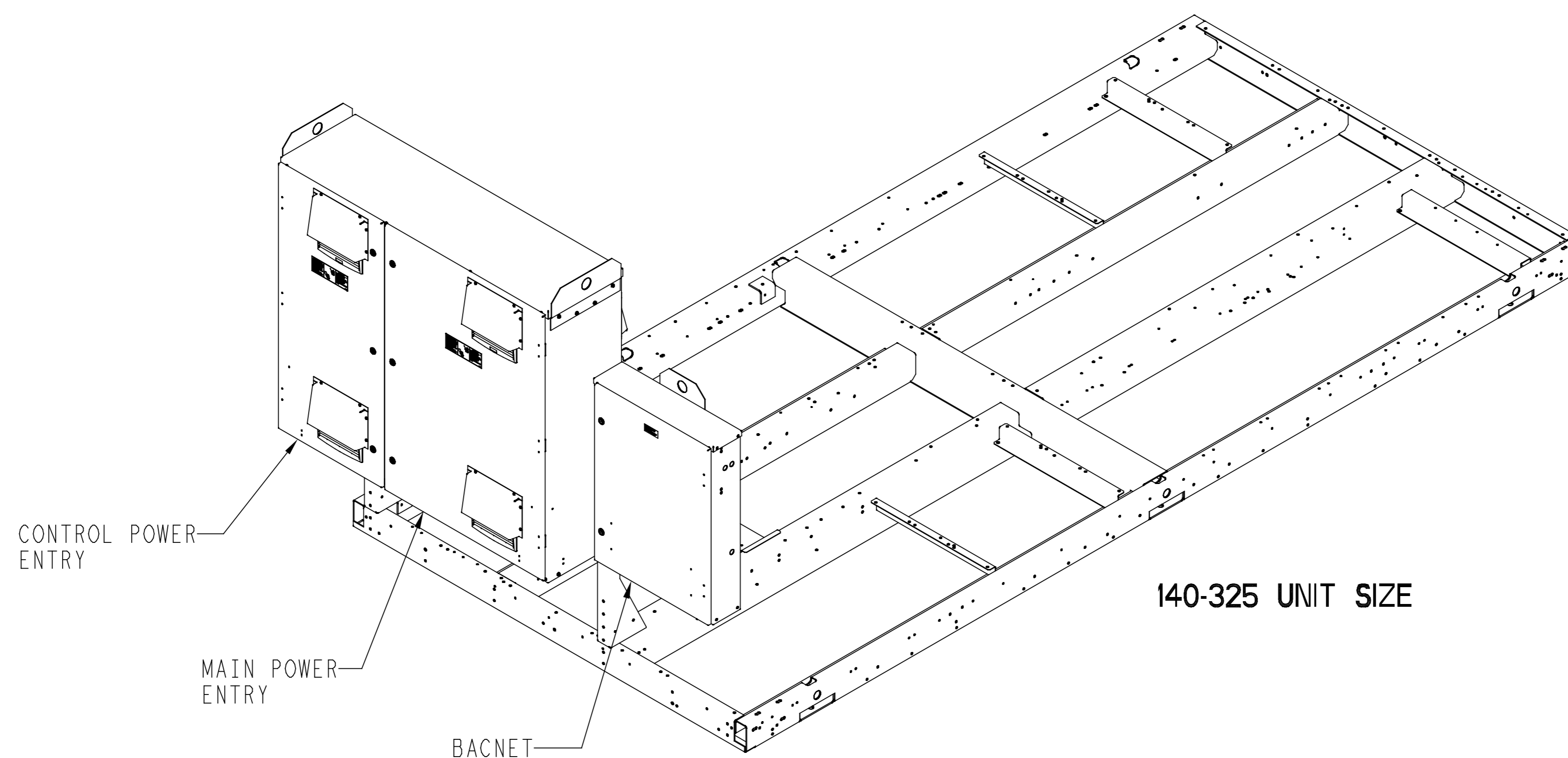

JOB NAME:
-

BUYER:
-

SALES OFFICE:
-

MODEL NO:
-

JOB NO:
-

P.O. NO:
-

PREPARED BY:
-

FIELD WIRING CHARACTERISTICS:
-

JOB SITE LOCATION:
-

SALES OFFICE:
-

REFERENTIAL NO:
-

NOTES:
-

COND: 1, 2A-1F
COOLER: 2, 2A-2C
FIELD WIRING DRAWING:
FWS

DATE: -
REVISION: ---

THIS DOCUMENT IS THE PROPERTY OF CARRIER CORP AND IS DELIVERED UPON THE EXPRESS CONDITION THAT THE CONTENTS WILL NOT BE REPRODUCED OR USED WITHOUT CARRIER CORP WRITTEN CONSENT.

SUBMISSION OF THESE DWGS OR DOCUMENTS DOES NOT CONSTITUTE PARTIAL OR FULL ACCEPTANCE OF CONTRACT.

CARRIER DWG # 02V60002800-014

REV: - SHEET 01 OF 01
DATE: 7-9-2020

SUPPLEMENTAL DWG. DATED:
-

30X

SHEET 03 OF 03

NOTES:

1. UNIT MUST HAVE CLEARANCES AS FOLLOWS:
 TOP— DO NOT RESTRICT.
 SIDES AND END— 6' FROM SOLID SURFACE.
 FOR AIRFLOW SIDE— 8' REQUIRED FOR COIL SERVICE AREA.
 IF MULTIPLE UNITS ARE INSTALLED AT THE SAME SITE, A MINIMUM SEPERATION OF 10FT (3M)
 BETWEEN THE SIDES OF THE MACHINES IS REQUIRED TO MAINTAIN PROPER AIRFLOW.
2. FACTORY WIRING IS IN ACCORDANCE WITH UL 1995 STANDARDS. FIELD MODIFICATIONS OR
 ADDITIONS MUST BE IN COMPLIANCE WITH ALL APPLICABLE CODES.
3. WIRING FOR MAIN FIELD SUPPLY MUST BE RATED 75C MINIMUM. USE COPPER FOR ALL UNITS.
4. TEMPERATURE RELIEF DEVICES ARE LOCATED ON LIQUID LINES, AND ECONOMIZER ASSEMBLIES
 AND HAVE 3/8" SAE FLARE CONNECTION. DO NOT CAP OR OTHERWISE OBSTRUCT
 TEMPERATURE/PRESSURE RELIEF.
5. PRESSURE RELIEF DEVICES ARE LOCATED ON THE EVAPORATOR (3/4" NPT MALE CONNECTOR) AND ON
 EACH OIL SEPERATOR (3/8" FLARE CONNECTOR).
6. DIMENSIONS SHOWN ARE IN INCHES, DIMENSIONS IN [] ARE IN MM.



P.O. BOX 4808, FORT RAINIER, IL, 60142

JOB NAME:
—

BUYER:
—

SALES ENG.:
—

MODEL NO.:
—

JOB NO.:
—

P.O. NO.:
—

PREPARED BY:
—

ELECTRICAL
CHARACTERISTICS:
—

JOBSITE LOCATION:
—

SALES OFFICE:
—

REFRIGERANT NO.:
—

NOTES:
—

COND: 1, 1A-1F
 COOLER: 2, 2A-2G
 MACHINE ASSEMBLY
 NOTES

DATE: —

REVISION: —

THIS DOCUMENT IS THE PRO-
 PERTY OF CARRIER CORP.
 AND IS DELIVERED UPON THE
 EXPRESS CONDITION THAT THE
 CONTENTS WILL NOT BE DIS-
 CLOSED OR USED WITHOUT
 CARRIER CORP. WRITTEN
 CONSENT.

SUBMISSION OF THESE DWG'S.
 OR DOCUMENTS DOES NOT
 CONSTITUTE PART PERFOR-
 MANCE OR ACCEPTANCE OF
 CONTRACT.

CARRIER DIAG #101V6000 600-1/14

REV. — SHIT 07 OF 07

DATE: 7-18-2020

SUPERSEDES DWG. DA LD:
—

30XV

SHT 07 OF 07

Outdoor Air-Cooled Liquid Chiller

HVAC Guide Specifications

Size Range: **140 to 500 Tons, Nominal**

(490 to 1760 kW, Nominal)

Carrier Model Number: **30XV with Greenspeed®**

Intelligence

Part 1 — General

1.01 SYSTEM DESCRIPTION

Microprocessor controlled, air-cooled liquid chiller for outdoor installation, utilizing variable speed screw compressors on all models, and utilizing low sound variable speed fans on all mid and high-tier models.

1.02 QUALITY ASSURANCE

- A. Unit shall be rated in accordance with AHRI (Air-Conditioning, Heating and Refrigeration Institute) Standard 550/590 (U.S.A.) latest edition and all units shall meet requirements of ASHRAE (American Society of Heating, Refrigeration and Air-Conditioning Engineers) Standard 90.1-2016.
- B. Unit construction shall comply with ASHRAE 15 Safety Code, UL (Underwriters Laboratories) 1995, and ASME (American Society of Mechanical Engineers) applicable codes (U.S.A. codes).
- C. The management system governing the manufacture of this product is ISO (International Organization for Standardization) 9001:2015 certified.
- D. An operational test, in which the chiller is run under load, is performed at the factory. This test checks for proper operation of fans as well as various controls and safeties, and a Certificate of Unit Testing, indicating successful end-of-line testing, is provided with the unit.

1.03 DELIVERY, STORAGE AND HANDLING

- A. Unit controls shall be capable of with- standing 150°F (65.5°C) storage temperatures in the control compartment.
- B. Unit shall be stored and handled per unit manufacturer's recommendations.

1.04 PHYSICAL LAYOUT

- A. Unit shall be located such that minimum recommended airflow clearances are maintained.
- B. If minimum recommended clearances cannot be maintained, an ExpertFit™ analysis must be performed. The Expert-Fit software model is available in the chiller selection program and predicts air-cooled chiller performance within a confined space.

Part 2 — Products

2.01 EQUIPMENT

NOTE: To avoid extended chiller downtime, when changing chiller sensors and/or instrumentation, no control panel reprogramming shall be required.

A. General:

Factory assembled, single-piece chassis, air-cooled liquid chiller. Contained within the unit cabinet shall be all factory wiring, piping, controls, refrigerant charge (R-134a), and special features required prior to field start-up.

B. Materials of Construction:

1. The base rail is industrial-quality, 7 ga, zinc-dipped galvanized frame (with Magni-coated screws).
2. Cabinet shall be galvanized steel casing with a baked enamel powder or pre-painted finish.
3. Painted parts shall withstand 1000 hours in constant neutral salt spray under ASTM B117 conditions with a 1 mm scribe per ASTM D1654. After test, painted parts shall show no signs of wrinkling or cracking, no loss of adhesion, no evidence of blistering, and the mean creepage shall not exceed 1/4 in. (Rating ≥ 4 per ASTM D1654) on either side of the scribe line.

C. Fans:

1. On standard-tier units, condenser fans shall be direct-driven, 9-blade airfoil cross-section, reinforced polymer construction, shrouded-axial type, and shall be statically and dynamically balanced with inherent corrosion resistance.
2. On mid-tier and high-tier units, condenser fans shall be variable speed, 9-blade airfoil cross-section, reinforced polymer construction, shrouded-axial type, and shall be statically and dynamically balanced with inherent corrosion resistance.
3. The variable speed drives for mid-tier and high-tier unit condenser fans shall include a DC link reactor.
4. Air shall be discharged vertically upward.
5. All VFDs on the chiller (compressor motors and fans) shall be fully air cooled and shall not require an additional glycol cooling system, thus avoiding the maintenance associated with such cooling systems.
6. Fans shall be protected by coated steel wire safety guards.
7. Fan blades shall have serrated edges to minimize the sound that is produced.
8. Variable speed condenser fans are not available for unit sizes 225-500 at 208/230 v or for unit size 140 at any voltage.

D. Compressor/Compressor Assembly:

1. Comprised of semi-hermetic twin screw type compressors.
2. Compressor motor shall be direct drive, VFD (variable frequency drive) controlled to match the load requirement, with a maximum speed of 5880 or 6300 rpm. The motors are protected by motor temperature sensors, and are suction gas cooled.
3. In order to optimally match building load, maximize chiller power factor and help equalize compressor run time, all chiller compressors must be VFD controlled.
4. For improved reliability with fewer moving parts, the compressor shall not employ a slide valve.
5. Capacity control shall utilize a VFD to unload each compressor from 100% to 25% of full load, resulting in a chiller minimum load of less than 15%. A VI (volume index) valve is used to optimize the efficiency at full and part load conditions.
6. The VFD for each compressor motor shall include a DC link reactor.
7. Compressor shall include an internal muffler to reduce pulsations in the system.
8. All VFDs on the chiller (compressor motors and fans) shall be fully air cooled and shall not require an additional glycol cooling system, thus avoiding the maintenance associated with such cooling systems. If supplying VFD glycol cooling system equipment, manufacturer must provide a separate line item in their quotation for the following:
 - a. Every five years glycol solution replacement and clean strainer
 - b. Yearly pH test
 - c. Yearly fluid level check
 - d. Yearly glycol condenser cleaning
 - e. Hail guard provided for glycol condenser section
 - f. The following list of critical parts must be provided:
 - g. Glycol pump
 - h. Glycol condenser or plate frame heat exchanger
 - i. Extra hoses and clamps
 - j. Backup fan coil fan
 - k. Backup fan coil evaporator

9. Compressor performance shall not rely on an internal Teflon¹ coating because this material deteriorates over time. This deterioration results in loss of capacity, higher operating costs due to lower efficiency and increased maintenance requirements.

E. Flooded Evaporator:

1. Shall be mechanically cleanable tubes in a shell-and-tube type evaporator with removable heads.
2. Tubes shall be internally enhanced seamless-copper type rolled into tube sheets.
3. Shall be equipped with Victaulic-type water connections.
4. Shell and evaporator heads shall be insulated with 3/4-in. PVC foam (closed-cell) with a maximum K factor of 0.28.
5. Design shall incorporate 2 independent refrigerant circuits.
6. Evaporator shall be tested and stamped in accordance with ASME Code for a refrigerant working side pressure of 220 psig (1517 kPa). Evaporator shall have a maximum water-side pressure of 300 psig (2068 kPa).
7. Evaporator shall have a evaporator drain and vent.
8. Low-ambient temperature protection: unit shall have factory-installed evaporator heater (where applicable) to protect evaporator from ambient temperature freeze down to 0°F (-17.8°C).
9. Evaporator shall be provided with a factory-installed flow switch.

Verify insulation protective coating on exposed surfaces.

F. Condenser:

1. Coil shall be air-cooled Novation® heat exchanger technology (MCHX) and shall have a series of flat tubes containing a series of multiple, parallel flow microchannels layered between the refrigerant manifolds. Novation coils shall consist of a two-pass arrangement. Coil construction shall consist of aluminum alloys for fins, tubes, and manifolds in combination with a corrosion-resistant coating.
2. Tubes shall be cleaned, dehydrated, and sealed.
3. Assembled condenser coils shall be pressure tested at the coil factory at 660 psig (5448 kPa) and subsequently shall be leak tested at 145 psig ±5 psig (1000 kPa ±34.5 kPa) and pressure tested at 350 psig (2413 kPa) at final unit assembly.
4. To plan the chiller installation and for ease of maintenance/coil removal, all refrigerant piping entering and leaving the condenser coils shall be located on only one side of the chiller so the coils can be removed (when needed) from the side free of piping. This is important to consider because removing the coils from the header side, although possible, involves extra labor due to extra bending and brazing of the coil headers.

G. Refrigeration Components:

Refrigerant circuit components shall include replaceable-core filter drier, moisture indicating sight glass, electronic expansion valve, discharge service valves and liquid line service valves, and complete operating charge of both refrigerant R-134a and compressor oil.

H. Controls, Safeties, and Diagnostics:

1. Unit controls shall include the following minimum components:
 - a. Microprocessor with non-volatile memory. Battery backup system shall not be accepted.
 - b. Separate terminal block for power and controls.
 - c. Separate 115-v power supply to serve all controllers, relays, and control components.
 - d. ON/OFF control switch.
 - e. Replaceable solid-state controllers.
 - f. Pressure sensors installed to measure suction, oil, economizer, discharge, and liquid pressure. Thermistors installed to measure evaporator entering and leaving fluid temperatures and outside-air temperature.

¹Teflon is a registered trademark of DuPont.

2. Unit controls shall include the following functions:
 - a. Automatic circuit lead/lag.
 - b. Capacity control based on leaving chilled fluid temperature and compensated by rate of change of return-fluid temperature with temperature set point accuracy to 0.1°F (0.05°C).
 - c. Limiting the chilled fluid temperature pull-down rate at start-up to an adjustable range of 0.2°F to 2°F (0.1 to 1.1°C) per minute to prevent excessive demand spikes at start-up.
 - d. Seven-day time schedule.
 - e. Leaving chilled fluid temperature reset from return fluid and outside air temperature.
 - f. Chilled water pump start/stop control.
 - g. Chiller control for parallel chiller applications without addition of hardware modules and control panels (requires thermistors).
 - h. Timed maintenance scheduling to signal maintenance activities for strainer maintenance and user-defined maintenance activities.
 - i. Low ambient protection to energize evaporator heaters (if installed).
 - j. Single step demand limit control activated by remote contact closure.
 - k. Night time sound mode to reduce the sound of the machine by a user-defined schedule.
3. Diagnostics:
 - a. The control panel shall include, as standard, a display:
 - 1) Seven-inch color touch screen display with stylus.
 - 2) Display shall allow a user to navigate through menus, select desired options and modify data.
 - b. Features of the display shall include:
 - 1) Multiple connection ports for USB, Ethernet or BACnet IP, LEN (local equipment network), and Carrier Comfort Network® (CCN) connections. NOTE: BACnet IP may require additional programming.
 - 2) Automatic reporting of alarms over email.
 - 3) Ability to graphically plot trends of system performance and conditions over time.
 - 4) Graphical summary display of current chiller operation and water conditions.
 - 5) Display shall allow access to configuration, maintenance, service, set point, time schedules, alarm history, and status data.
 - 6) Three levels of password protection against unauthorized access to configuration and maintenance information, and display set up parameters.
 - 7) Full compatibility with the Carrier Comfort Network® (CCN) system to provide email alarm notification and to provide network capability to fully monitor and control chiller.
 - 8) Display shall be capable of displaying the last 50 alarms with clear full text description and time and date stamp, and will store a snapshot of operating conditions before and after the 10 most recent alarms.
 - 9) Display run hours and number of starts for machine and individual compressors.
 - 10) Display current draw for each circuit compressor and fans.
 - 11) The control system shall allow software upgrade without the need for new hardware modules.
4. Safeties:
 - a. Unit shall be equipped with thermistors and all necessary components in conjunction with the control system to provide the unit with the following protections:
 - 1) Reverse rotation.
 - 2) Low chilled fluid temperature.
 - 3) Motor overtemperature.
 - 4) High pressure.
 - 5) Electrical overload.
 - 6) Loss of phase.
 - 7) Loss of chilled water flow.
 - b. Condenser-fan motors shall have internal overcurrent protection.

I. Operating Characteristics:

1. Unit, without modification, shall be capable of starting and running at outdoor ambient temperatures from 32°F (0°C) to 125.6°F (52°C) for all units employing variable speed condenser fans and outdoor ambient temperatures from 32°F (0°C) to 105°F (40.6°C) for units that do not employ variable speed condenser fans. Selections up to 125.6°F (52°C) must be provided when requested, and both mid and high tier units shall be operational up to 131°F (55°C).
2. Unit shall be capable of starting up with 95°F (35°C) entering fluid temperature to the evaporator.
3. After power restoration, and with the Capacity Recovery™ feature (a standard controls feature) enabled, unit shall be capable of full capacity recovery in less than 5 minutes.

J. Motors:

Condenser-fan motors shall be totally enclosed, air over, variable speed, 3-phase type with permanently lubricated bearings and Class F insulation. Fans shall be 8-pole for standard tier units and 6-pole for medium and high tier units.

K. Electrical Requirements:

1. Unit primary electrical power supply shall enter the unit at a single location (all chiller voltage/size combinations shall have the ability to accommodate 2 power supplies to meet job-specific requirements).
2. Primary electrical power supply shall be rated to operate up to 125.6°F (52°C) ambient temperature for all models.
3. Unit shall operate on 3-phase power at the voltage shown in the equipment schedule.
4. Control points shall be accessed through terminal block.
5. Unit shall be shipped with factory control and power wiring installed.
6. Unit shall have a standard SCCR (short circuit current rating) value of 25 kA for all voltages other than 575-v, and 10 kA for 575-v units.

L. Chilled Water Circuit:

1. Chilled water circuit shall be rated for 300 psig (2068 kPa). Units with optional hydronic kit are rated for 150 psig(1034kPa) working pressure.
2. Thermal dispersion proof of flow switch shall be factory installed and wired.

N. Special Features:

Certain standard features are not applicable when the features designated by * are specified. For assistance in amending the specifications, contact your Carrier representative.

1. Variable Speed Condenser Fans:

All fans on the unit shall have variable speed fan motors to provide higher part load efficiency and reduced acoustic levels. Each fan circuit shall have a factory-installed, independent variable speed drive with display. Variable speed drives are rated IP-55 enclosures and UL Listed. The use of this option, with the addition of anti-freeze in the evaporator circuit and wind baffles, shall allow running with outdoor ambient temperatures down to -20°F (-29°C). Variable speed condenser fans also allow the chiller to operate at ambient temperatures as high as 125.6°F (52°C). This option is only available on standard-tier units because both mid-tier and high-tier units are automatically provided with this functionality. Variable speed condenser fans are not available for unit sizes 225-500 at 208/230 v or for unit size 140 standard tier at any voltage.

2. Unit-Mounted Non-Fused Disconnect:

Unit shall be supplied with factory-installed, lockable, non-fused electrical disconnect for main power supply. This factory option is not available with dual point power in sizes 350-500.

3. Energy Management Module:

A factory or field-installed module shall provide the following energy management capabilities: 4 to 20 mA signals for leaving fluid temperature reset, cooling set point reset or demand limit control; 2-step demand limit control (from 0% to 100%) activated by a remote contact closure; and discrete input for "Ice Done" indication for ice

storage system interface. When a factory-installed version of this device is selected, a GFI convenience outlet is also included.

4. Condenser Coil Trim Panels:

Unit shall be supplied with factory-installed or field-installed coil covers. Factory-installed coil trim panels are not available when a factory-installed full hail guard is selected.

5. Isolation Valve Option:

Unit shall be supplied with factory-installed isolation valve which provides a means of isolating the compressors from the evaporator vessel, which is beneficial in servicing the chiller. The isolation option comes in various configurations depending on the installation region (Middle Eastern or elsewhere). On all units which are not installed in the Middle East region, a liquid line service valve and a motorized discharge isolation valve are always provided per refrigerant circuit. For Middle Eastern regions only, a manual discharge valve is standard and a motorized discharge ball valve is optional. The selection of the isolation valve option results in chillers which are equipped with a liquid line service valve, a discharge service valve (motorized or manual type), and a series of valves on or near the evaporator. The net effect is to provide isolation capability in the condenser area, the evaporator area and the compressor area.

NOTE: The only situation in which the isolation of the condenser area allows the full charge to be stored in the condenser is when round tube, plate fin (RTPF) coils are employed.

6. Suction Line Insulation:

Unit shall be supplied with suction line insulation. Insulation shall be tubular closed-cell insulation. This option shall be required with applications with leaving fluid temperatures below 30°F (-1.1°C) and recommended for areas of high dewpoints where condensation may be a concern.

7. Control Transformer:

Unit shall be supplied with a factory-installed transformer that will allow supply control circuit power from the main unit power supply. This is automatically provided on 50 Hz chillers.

8. GFI Convenience Outlet:

Shall be field-installed and mounted with easily accessible 115-v female receptacle. Shall include 4-amp GFI (ground fault interrupt) receptacle. Not available with 380-v units. This item is automatically included when a factory-installed energy management module is selected.

9. High SCCR (Short Circuit Current Rating):

The optional high SCCR (short circuit current rating) device shall allow the chiller to tolerate a 65 kA (all voltages except 575-v) or a 35 kA (575-v units) short circuit current for a brief period of time while protecting downstream components. The high SCCR option shall provide a higher level of protection than the standard unit. At 208/230-v, this option is only available with the combination of dual point power and unit sizes 140-200. For unit sizes 350-500, when dual-point power is selected, two molded case switches will be provided, and non-fused disconnects are not available.

10. Full Hail Guard:

Unit shall be equipped with factory or field-installed louvered panels on the sides and ends of the machine which firmly fasten to the machine frame. These panels shall cover the unit from top to bottom, thus negating any need for coil trim panels. For all chillers which are designed with vertical coils on the outside of the unit, full hail guard coverage shall be required to protect the unit from exposure to the elements.

11. Low Sound Kit:

Unit shall be provided with factory-installed sheet metal enclosures with sound-absorbing panels for each compressor as well as an external muffler between each compressor and its associated oil separator.

12. Sound Optimization:

Unit shall be selected with customized software to best meet customer sound and capacity requirements.

Detailed Performance Summary For CH-1

Project: CMS Hidden Valley, Grier, Newell
 Prepared By: Paul Shelor

04/27/2022
 03:51 PM



AquaForce™ Air-Cooled Variable Speed Screw Chiller



Unit Information

Tag Name: **CH-1**
 Model Number: **30XV250S**
 Condenser Type: **Air Cooled**
 Compressor Type: **VFD Screw**
 Nameplate Voltage: **460-3-60 V-Ph-Hz**
 Quantity: **1**
 Manufacturing Source: **Charlotte, NC USA**
 ASHRAE 90.1: **2013/2016, 2010, 2007**
 Refrigerant: **R-134a**
 Minimum Capacity: **15.00** %
 Shipping Weight: **15660** lb
 Operating Weight: **15958** lb
 Refrigerant Weight (Circuit A): **160** lb
 Refrigerant Weight (Circuit B): **170** lb
 Unit Length: **299** in
 Unit Width: **88** in
 Unit Height: **99** in
 Required Pad Length: **282** in
 Minimum Outdoor Operating Temp: **-20.0** °F

Condenser Information

Altitude: **0.000** ft
 Number of Fans: **12**
 Total Condenser Fan Air Flow: **174,000** CFM
 Entering Air Temperature: **95.0** °F

Integrated Pump Information

No Pump Selected

Accessories and Installed Options

Isolation Valve(s)
 Suction Line Insulation
 Control Transformer
 Non-Fused Disconnect
 EMM (includes GFI Convenience Outlet)
 Flooded Evaporator, 2 pass, w/ Heater
 Variable Speed Condenser Fans
 High SCCR 65 kA Current Rating
 None
 Full Hail Guard
 Low Ambient Head Pressure Control
 Standard Tier

Performance Information

Cooling Capacity: **259.5** Tons
 Total Compressor Power: **267.3** kW
 Total Fan Motor Power: **23.52** kW
 Total Unit Power (without pump): **295.4** kW
 Efficiency (without pump) (EER): **10.54** BTU/Wh

Electrical Information

Unit Voltage: **460-3-60** V-Ph-Hz
 Connection Type: **Single Point**
 Minimum Voltage: **414** Volts
 Maximum Voltage: **506** Volts
 SCCR: **65** kA

Evaporator Information

Fluid Type: **Fresh Water**
 Fouling Factor: **0.000100** (hr-sqft-F)/BTU
 Leaving Temperature: **44.00** °F
 Entering Temperature: **56.00** °F
Fluid Flow: 517.3 gpm
 Fluid Flow Min: **270.0** gpm
 Fluid Flow Max: **1,234** gpm
Pressure Drop: 14.2 ft H2O

Amps	Electrical	Electrical
	Circuit 1	Circuit 2
MCA	493.0	---
MOCP	600.0	---
Rec Fuse Size	600.0	---

Detailed Performance Summary For CH-1

Project: CMS Hidden Valley, Grier, Newell
 Prepared By: Paul Shelor

04/27/2022
 03:51 PM

Integrated Part Load Value (AHRI)

IPLV:IP:.....18.38 BTU/Wh

Unit Performance				
Percent of Full Load Capacity, %	100.00	75.00	50.00	25.00
Percent of Full Load Power, %	100.00	54.03	25.85	10.66
Unloading Sequence	A	A	A	A
Cooling Capacity, Tons	259.3	194.5	129.6	64.82
Total Unit Power, kW	295.3	159.6	76.33	31.50
Efficiency (EER), BTU/Wh	10.53	14.62	20.38	24.70
Evaporator Data				
Fluid Entering Temperature, °F	54.00	51.49	48.99	46.50
Fluid Leaving Temperature, °F	44.00	44.00	44.00	44.00
Fluid Flow Rate, gpm	620.0	620.0	620.0	620.0
Fouling Factor, (hr-sqft-F)/BTU	0.000100	0.000100	0.000100	0.000100
Pressure Drop, psi	8.91	8.95	8.99	9.03
Condenser Data				
Entering Air Temperature, °F	95.0	80.0	65.0	55.0

Sound power measured in accordance with ANSI/AHRI Standard 370-2015.



Certified in accordance with the AHRI Air-Cooled Water-Chilling Packages Certification Program, which is based on AHRI Standard 550/590 (I-P) and AHRI Standard 551/591 (SI). Certified units may be found in the AHRI Directory at www.ahridirectory.org.

Detailed Performance Summary For CH-1

Project: CMS Hidden Valley, Grier, Newell
 Prepared By: Paul Shelor

04/27/2022
 03:51 PM

Unit Parameters

Tag Name:..... **CH-1**
 Model Number:..... **30XV250**
 Condenser Type:..... **Air Cooled**
 Compressor Type:..... **VFD Screw**
 Chiller Nameplate Voltage:..... **460-3-60** V-Ph-Hz
 Quantity:..... **1**
 Manufacturing Source:..... **Charlotte, NC USA**
 Refrigerant:..... **R-134a**
 Shipping Weight:..... **15660** lb
 Operating Weight:..... **15958** lb
 Refrigerant Weight (Circuit A):..... **160** lb
 Refrigerant Weight (Circuit B):..... **170** lb
 Unit Length:..... **299** in
 Unit Width:..... **88** in
 Unit Height:..... **99** in
 Required Pad Length:..... **282** in

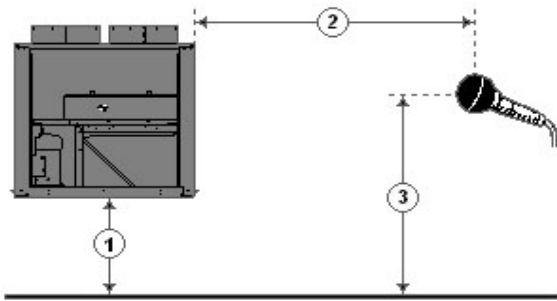

1 - Chiller Height Above Ground
 2 - Horizontal Distance From Chiller to Receiver
 3 - Receiver Height Above Ground
 (See Note 3)

Accessories and Installed Options

Isolation Valve(s)	Flooded Evaporator, 2 pass, w/ Heater
Suction Line Insulation	Variable Speed Condenser Fans
Control Transformer	High SCCR 65 kA Current Rating
Non-Fused Disconnect	None
EMM (includes GFI Convenience Outlet)	Full Hail Guard

Acoustic Information

Table 1. A-Weighted Sound Power Levels (dB re 1 picowatt). See note #1.

Octave Band Center Frequency, Hz	63	125	250	500	1k	2k	4k	8k	Overall
100% Load	65	79	83	95	96	97	91	79	101
75% Load	63	76	82	90	90	87	79	74	94
50% Load	60	70	79	84	85	80	71	71	89
25% Load	57	67	76	81	82	78	68	68	86

Table 2. A-Weighted Sound Pressure Levels (dB re 20 micropascals) calculated based upon user defined input for dimensions 1, 2 and 3 as shown in above diagram. See note #2 and #3.

Octave Band Center Frequency, Hz	63	125	250	500	1k	2k	4k	8k	Overall
100% Load	36	49	54	65	67	67	62	50	72
75% Load	33	47	52	60	60	58	50	44	65
50% Load	30	41	49	55	55	50	42	41	59
25% Load	27	38	47	52	53	48	39	38	57

- Notes: (1) Measurements performed in accordance with AHRI Standard 370-2015 for air cooled Chillers.
 (2) Chiller is assumed to be a point source on a reflecting plane.
 (3) Without user defined input, the default dimensions used to construct Table 2 are as follows:
 1 - Chiller Height Above Ground = 0.0 ft
 2 - Horizontal Distance From Chiller to Receiver = 30.0 ft
 3 - Receiver Height Above Ground = 3.0 ft

30XV 200T-250T — ENGLISH

UNIT 30XV WITH FLOODED EVAPORATOR	200			225			250		
TIER (MODEL NO. POS. 10)	S	M	H	S	M	H	S	M	H
CHASSIS DIMENSIONS (in.) (Note 1)									
Length	254.6	301.6	348.6	251.7	298.7	345.7	298.7	345.7	392.7
Width					88.0				
Height					98.9				
SHIPPING WEIGHT (lb) (Note 2)									
Al-Cu Condenser Coil	12,785	14,004	14,943	13,627	14,667	15,715	15,893	17,117	18,316
Cu-Cu Condenser Coil	14,207	15,690	16,911	15,033	16,383	17,881	17,580	19,085	20,565
MCHX Condenser Coil	12,090	13,157	13,946	12,902	13,810	14,677	15,117	16,170	17,217
Al-Cu Condenser Coil with Pump Option*	—	15,169	16,415	—	—	16,880	—	—	19,481
Cu-Cu Condenser Coil with Pump Option*	—	16,856	18,383	—	—	19,046	—	—	21,730
MCHX Condenser Coil with Pump Option*	—	14,322	15,418	—	—	15,842	—	—	18,382
OPERATING WEIGHT (lb) (Note 3)									
Al-Cu Condenser Coil	13,012	14,260	15,200	13,910	14,965	16,013	16,191	17,514	18,712
Cu-Cu Condenser Coil	14,433	15,947	17,167	15,316	16,681	18,179	17,878	19,482	20,961
MCHX Condenser Coil	12,317	13,413	14,202	13,185	14,108	14,975	15,415	16,566	17,614
Al-Cu Condenser Coil with Pump Option*	—	15,641	16,887	—	—	17,394	—	—	20,093
Cu-Cu Condenser Coil with Pump Option*	—	17,256	18,855	—	—	19,560	—	—	22,342
MCHX Condenser Coil with Pump Option*	—	14,722	15,890	—	—	16,356	—	—	18,995
REFRIGERANT TYPE (Standard Evaporator)									
	R-134a EXV Controlled System								
Refrigerant Charge (lb) Ckt A/ Ckt B (RTPF)	195/205	213/223	231/241	253/187	276/210	294/228	238/248	266/276	284/294
Refrigerant Charge (lb) Ckt A/ Ckt B (MCHX)	130/140	135/145	140/150	175/135	185/145	190/150	160/170	175/185	180/190
REFRIGERANT TYPE (Brine Evaporator)									
	R-134a EXV Controlled System								
Refrigerant Charge (lb) Ckt A/ Ckt B (RTPF)	215/225	233/243	251/261	273/207	296/230	314/248	258/268	276/286	294/304
Refrigerant Charge (lb) Ckt A/ Ckt B (MCHX)	150/160	155/165	160/170	195/155	205/165	210/170	180/190	185/195	190/200
COMPRESSOR									
	Semi-Hermetic Twin Rotary Screw								
Quantity	2	2	2	2	2	2	2	2	2
Full Load Capacity Split Ckt A / Ckt B (Note 4)	50/50	50/50	50/50	60/40	60/40	60/40	50/50	50/50	50/50
Oil Charge (gal) Ckt A/Ckt B	5.5/5.5	5.5/5.5	5.5/5.5	6.0/5.5	6.0/5.5	6.0/5.5	6.0/6.0	6.0/6.0	6.0/6.0
Minimum Capacity (%) (Note 5)	<15	<15	<15	<15	<15	<15	<15	<15	<15
EVAPORATOR									
Net Fluid Volume (gal.)	27	31	31	34	36	36	36	48	48
Maximum Refrigerant Pressure (psig)	220	220	220	220	220	220	220	220	220
Maximum Water-Side Pressure (psig)	300	300	300	300	300	300	300	300	300
WATER CONNECTIONS									
Drain (NPT, in.)	3/8	3/8	3/8	3/8	3/8	3/8	3/8	3/8	3/8
Standard (2-Pass), Inlet and Outlet, Victaulic (in.) Fresh Water/Comfort Brine	5/5	6/6	6/6	6/6	6/6	6/6	6/6	8/8	8/8
1 Pass, Inlet and Outlet, Victaulic (in.) Fresh Water/Process Brine	5/—	8/6	8/—	8/—	8/—	8/—	8/—	8/8	8/—
3 Pass, Inlet and Outlet, Victaulic (in.) Fresh Water/Comfort Brine	5/5	5/5	5/5	6/6	6/6	6/6	6/6	8/6	8/6
Std (2-Pass) & 3-Pass w/Pump, Inlet and Outlet, Victaulic (in.) Fresh Water	6/6	6/6	6/6	6/6	6/6	6/6	6/6	6/6	6/6
Std (2-Pass) & 3-Pass w/Pump, Inlet and Outlet, Victaulic (in.) Comfort Brine	6/6	6/6	6/6	6/6	6/6	6/6	6/6	6/6	6/6
CONDENSER FANS (Note 6)									
	Shrouded Axial Type, Vertical Discharge								
Maximum Fan Speed (rpm)	1140	1140	1140	1140	1140	1140	1140	1140	1140
No. Fans (Ckt A/ Ckt B)	5/5	6/6	7/7	6/4	7/5	8/6	6/6	7/7	8/8
Total Airflow (cfm) RTPF Coil	131,400	157,680	183,960	131,400	157,680	183,960	157,680	183,960	210,240
Total Airflow (cfm) MCHX Coil	145,000	174,000	203,000	145,000	174,000	203,000	174,000	203,000	232,000
CONDENSER COILS									
No. Coils (Ckt A/ Ckt B)	5/5	6/6	7/7	6/4	7/5	8/6	6/6	7/7	8/8

LEGEND

Cu	—	Copper
Al	—	Aluminum
EXV	—	Electronic Expansion Valve
MCHX	—	Microchannel Heat Exchanger
RTPF	—	Round Tube/Plate Fin

* The indicated weights for units with the pump option should assume that the unit is provided with the maximum number of pumps available for the application. In certain instances, one less pump may be provided.

NOTES:

- More precise dimensions are available on the certified prints.
- Unit shipping weight includes the base unit plus coil trim panels, but no other options or accessories are included. The shipping weight is equal to the operating weight (indicated above) minus the weight of the water in the evaporator.
- Unit operating weight includes the base unit plus coil trim panels, but no other options or accessories are included. Selected options and accessories will slightly alter the unit weight. See pages 17-28 for the mounting weight detail.
- The capacity split is indicative of both compressors operating at a full load condition. The actual capacity split at most operating conditions will not match these values.
- The minimum capacity is less than 15% for units sized at full capacity. Please use the chiller selection program to determine actual minimum capacity values.
- Standard-tier models without the variable speed condenser fan option have a maximum speed of 840 rpm.

APPENDIX E — BACNET IP POINTS

OBJECT NAME	OBJECT TYPE	INSTANCE	OPTION	PV ACCESS	DESCRIPTION
ALARMRST_alarm_1	AV	110	IR	RO	Jbus Current Alarm 1
ALARMRST_alarm_2	AV	111	IR	RO	Jbus Current Alarm 2
ALARMRST_alarm_3	AV	112	IR	RO	Jbus Current Alarm 3
ALARMRST_alarm_4	AV	113	IR	RO	Jbus Current Alarm 4
ALARMRST_alarm_5	AV	114	IR	RO	Jbus Current Alarm 5
ALARMRST_ALM	AV	109		RO	Alarm State
ALARMRST_RST_ALM	BV	72		RO	Alarm Reset
ALM_AUX1_1_COM_F	BV	157	IR	RO	AUX1_1_COM_F
ALM_AUX1_2_COM_F	BV	158	IR	RO	AUX1_2_COM_F
ALM_AUX1_3_COM_F	BV	159	IR	RO	AUX1_3_COM_F
ALM_AUX1_4_COM_F	BV	160	IR	RO	AUX1_4_COM_F
ALM_CCN_EMSTOP_F	BV	186	IR	RO	CCN_EMSTOP_F
ALM_CHWSTEMP_F	BV	133	IR	RO	CHWSTEMP_F
ALM_COOL_EWT_F	BV	130	IR	RO	COOL_EWT_F
ALM_COOL_LWT_F	BV	131	IR	RO	COOL_LWT_F
ALM_COOL_PUMP1_F	BV	187	IR	RO	COOL_PUMP1_F
ALM_COOL_PUMP2_F	BV	188	IR	RO	COOL_PUMP2_F
ALM_COOLER_FLOW_F	BV	196	IR	RO	COOLER_FLOW_F
ALM_COOLER_FREEZE_F	BV	170	IR	RO	COOLER_FREEZE_F
ALM_CP_TMP_A_F	BV	140	IR	RO	CP_TMP_A_F
ALM_CP_TMP_B_F	BV	141	IR	RO	CP_TMP_B_F
ALM_DATABASE_F	BV	220	IR	RO	DATABASE_F
ALM_DGT_A_T_F	BV	136	IR	RO	DGT_A_T_F
ALM_DGT_B_T_F	BV	137	IR	RO	DGT_B_T_F
ALM_DP_A_F	BV	145	IR	RO	DP_A_F
ALM_DP_B_F	BV	146	IR	RO	DP_B_F
ALM_ECO_P_A_F	BV	151	IR	RO	ECO_P_A_F
ALM_ECO_P_B_F	BV	152	IR	RO	ECO_P_B_F
ALM_ECO_T_A_F	BV	142	IR	RO	ECO_T_A_F
ALM_ECO_T_B_F	BV	143	IR	RO	ECO_T_B_F
ALM_EMM_BRD_COM_F	BV	161	IR	RO	EMM_BOARD_COM_F
ALM_FAN_DRIVE_A1_ALERT	BV	210	IR	RO	FAN_DRIVE_A1_ALERT
ALM_FAN_DRIVE_A1_F	BV	202	IR	RO	FAN_DRIVE_A1_F
ALM_FAN_DRIVE_A2_ALERT	BV	211	IR	RO	FAN_DRIVE_A2_ALERT
ALM_FAN_DRIVE_A2_F	BV	203	IR	RO	FAN_DRIVE_A2_F
ALM_FAN_DRIVE_A3_ALERT	BV	212	IR	RO	FAN_DRIVE_A3_ALERT
ALM_FAN_DRIVE_A3_F	BV	204	IR	RO	FAN_DRIVE_A3_F
ALM_FAN_DRIVE_B1_ALERT	BV	213	IR	RO	FAN_DRIVE_B1_ALERT
ALM_FAN_DRIVE_B1_F	BV	205	IR	RO	FAN_DRIVE_B1_F
ALM_FAN_DRIVE_B2_ALERT	BV	214	IR	RO	FAN_DRIVE_B2_ALERT
ALM_FAN_DRIVE_B2_F	BV	206	IR	RO	FAN_DRIVE_B2_F
ALM_FAN_DRIVE_B3_ALERT	BV	215	IR	RO	FAN_DRIVE_B3_ALERT
ALM_FAN_DRIVE_B3_F	BV	207	IR	RO	FAN_DRIVE_B3_F
ALM_FAN_DRIVEA1_COM_F	BV	164	IR	RO	FAN_DRIVEA1_COM_F
ALM_FAN_DRIVEA2_COM_F	BV	165	IR	RO	FAN_DRIVEA2_COM_F
ALM_FAN_DRIVEA3_COM_F	BV	166	IR	RO	FAN_DRIVEA3_COM_F
ALM_FAN_DRIVEB1_COM_F	BV	167	IR	RO	FAN_DRIVEB1_COM_F
ALM_FAN_DRIVEB2_COM_F	BV	168	IR	RO	FAN_DRIVEB2_COM_F

LEGEND

AV — Analog Value	IR — Intrinsic Reporting
BV — Binary Value	RO — Read Only
CMD — Command	RW — Read Write
COV — Change of Value	TL — Trend Log

APPENDIX E — BACNET IP POINTS (cont)

OBJECT NAME	OBJECT TYPE	INSTANCE	OPTION	PV ACCESS	DESCRIPTION
ALM_FAN_DRIVEB3_COM_F	BV	169	IR	RO	FAN_DRIVEB3_COM_F
ALM_HIGH_CP_TMP_A_F	BV	216	IR	RO	HIGH_CP_TMP_A_F
ALM_HIGH_CP_TMP_B_F	BV	217	IR	RO	HIGH_CP_TMP_B_F
ALM_HIGH_DGT_A_F	BV	192	IR	RO	HIGH_DGT_A_F
ALM_HIGH_DGT_B_F	BV	193	IR	RO	HIGH_DGT_B_F
ALM_HP_SWITCH_A_F	BV	218	IR	RO	HP_SWITCH_A_F
ALM_HP_SWITCH_B_F	BV	219	IR	RO	HP_SWITCH_B_F
ALM_ILL_FACT_CONF_F	BV	185	IR	RO	ILL_FACT_CONF_F
ALM_INI_FACT_CONF_F	BV	184	IR	RO	INI_FACT_CONF_F
ALM_LENSCAN_F	BV	221	IR	RO	LENSCAN_F
ALM_LIQUID_P_A_F	BV	153	IR	RO	LIQUID_P_A_F
ALM_LIQUID_P_B_F	BV	154	IR	RO	LIQUID_P_B_F
ALM_LIQUID_T_A_F	BV	138	IR	RO	LIQUID_T_A_F
ALM_LIQUID_T_B_F	BV	139	IR	RO	LIQUID_T_B_F
ALM_LOCK_F	BV	173	IR	RO	LOCK_F
ALM_LOSS_COM_MS_F	BV	174	IR	RO	LOSS_COM_MS_F
ALM_LOW_OIL_A_P_F	BV	175	IR	RO	LOW_OIL_A_P_F
ALM_LOW_OIL_B_P_F	BV	176	IR	RO	LOW_OIL_B_P_F
ALM_LOW_OIL_LEVEL_A_F	BV	181	IR	RO	LOW_OIL_LEVEL_A_F
ALM_LOW_OIL_LEVEL_B_F	BV	182	IR	RO	LOW_OIL_LEVEL_B_F
ALM_LOW_SUCTION_A_F	BV	171	IR	RO	LOW_SUCTION_A_F
ALM_LOW_SUCTION_B_F	BV	172	IR	RO	LOW_SUCTION_B_F
ALM_M_S_CONFIG_F	BV	183	IR	RO	M_S_CONFIG_F
ALM_OAT_F	BV	132	IR	RO	OAT_F
ALM_OIL_DROP_A_P_F	BV	179	IR	RO	OIL_DROP_A_P_F
ALM_OIL_DROP_B_P_F	BV	180	IR	RO	OIL_DROP_B_P_F
ALM_OIL_FILT_A_P_F	BV	177	IR	RO	OIL_FILT_A_P_F
ALM_OIL_FILT_B_P_F	BV	178	IR	RO	OIL_FILT_B_P_F
ALM_OIL_P_A_F	BV	149	IR	RO	OIL_P_A_F
ALM_OIL_P_B_F	BV	150	IR	RO	OIL_P_B_F
ALM_REFRIG_ESCAPE_F	BV	191	IR	RO	REFRIGERANT_ESCAPE_F
ALM_SCT_OUT_OF_CP_M_A_F	BV	189	IR	RO	SCT_OUT_OF_CP_MAP_A_F
ALM_SCT_OUT_OF_CP_M_B_F	BV	190	IR	RO	SCT_OUT_OF_CP_MAP_B_F
ALM_SENSORS_SWAP_F	BV	197	IR	RO	SENSORS_SWAP_F
ALM_SIOB1_COM_F	BV	155	IR	RO	SIOB1_COM_F
ALM_SIOB2_COM_F	BV	156	IR	RO	SIOB2_COM_F
ALM_SP_A_F	BV	147	IR	RO	SP_A_F
ALM_SP_B_F	BV	148	IR	RO	SP_B_F
ALM_SPACE_TEMP_F	BV	144	IR	RO	SPACE_TEMP_F
ALM_SST_OUT_OF_CP_M_A_F	BV	198	IR	RO	SST_OUT_OF_CP_MAP_A_F
ALM_SST_OUT_OF_CP_M_B_F	BV	199	IR	RO	SST_OUT_OF_CP_MAP_B_F
ALM_STEPPER_ECO_A_F	BV	224	IR	RO	STEPPER_ECO_A_F
ALM_STEPPER_ECO_B_F	BV	225	IR	RO	STEPPER_ECO_B_F
ALM_STEPPER_EXV_A_F	BV	222	IR	RO	STEPPER_EXV_A_F
ALM_STEPPER_EXV_B_F	BV	223	IR	RO	STEPPER_EXV_B_F
ALM_SUCT_VALV_CLOSD_A_F	BV	194	IR	RO	SUCT_VALV_CLOSED_A_F
ALM_SUCT_VALV_CLOSD_B_F	BV	195	IR	RO	SUCT_VALV_CLOSED_B_F
ALM_SUCTION_T_A_F	BV	134	IR	RO	SUCTION_T_A_F

LEGEND

AV — Analog Value	IR — Intrinsic Reporting
BV — Binary Value	RO — Read Only
CMD — Command	RW — Read Write
COV — Change of Value	TL — Trend Log

APPENDIX E — BACNET IP POINTS (cont)

OBJECT NAME	OBJECT TYPE	INSTANCE	OPTION	PV ACCESS	DESCRIPTION
ALM_SUCTION_T_B_F	BV	135	IR	RO	SUCTION_T_B_F
ALM_VI_DIAG_A_ALERT	BV	226	IR	RO	VI_DIAG_A_ALERT
ALM_VI_DIAG_B_ALERT	BV	227	IR	RO	VI_DIAG_B_ALERT
ALM_VLT_DRIVE_A_ALERT	BV	208	IR	RO	VLT_DRIVE_A_ALERT
ALM_VLT_DRIVE_A_F	BV	200	IR	RO	VLT_DRIVE_A_F
ALM_VLT_DRIVE_B_ALERT	BV	209	IR	RO	VLT_DRIVE_B_ALERT
ALM_VLT_DRIVE_B_F	BV	201	IR	RO	VLT_DRIVE_B_F
ALM_VLT_DRIVE1_COM_F	BV	162	IR	RO	VLT_DRIVE1_COM_F
ALM_VLT_DRIVE2_COM_F	BV	163	IR	RO	VLT_DRIVE2_COM_F
BACNET_bacena	BV	117		RO	BACnet Enable
BACNET_bacunit	BV	118		RO	Metric Units? (Blackbox)
BACNET_bcmd	AV	515		RO	BACnet Management Device
BACNET_ident	AV	514		RO	Identifier
BACNET_network	AV	513		RO	Network
CAPACTRL_cap_lim	AV	191	IR	RO	Current Capacity Limit
CAPACTRL_cap_pc_a	AV	196	IR	RO	Estimated Capacity A
CAPACTRL_cap_pc_b	AV	201	IR	RO	Estimated Capacity B
CAPACTRL_capmoda	AV	193	IR	RO	Capa Ctrl Stat Nb A
CAPACTRL_capmodb	AV	198	IR	RO	Capacity Ctrl Stat Nb B
CAPACTRL_CirRunNb	AV	207	IR	RO	Circuit Running Number
CAPACTRL_cMaxFrqA	AV	202	IR	RO	Max Comp. Frequency A
CAPACTRL_cMaxFrqB	AV	203	IR	RO	Max Comp. Frequency B
CAPACTRL_ctrl_wt	AV	189	IR	RO	Controlled Water Temp
CAPACTRL_cwt_rate	AV	190	IR	RO	Ctrl Water Temp, Deg/Min
CAPACTRL_drvcmda	AV	192	IR	RO	Wished Comp. Frequency A
CAPACTRL_drvcmdb	AV	197	IR	RO	Wished Comp. Frequency B
CAPACTRL_DualMast	AV	210	IR	RO	Dual Circuit Master
CAPACTRL_icapmoda	AV	194	IR	RO	Last Capa Ctrl Stat Nb A
CAPACTRL_icapmodb	AV	199	IR	RO	Last Capa Ctrl Stat Nb B
CAPACTRL_overrida	AV	195	IR	RO	Override Capacity Nb A
CAPACTRL_overridb	AV	200	IR	RO	Override Capacity Nb B
CAPACTRL_reset	AV	206	IR	RO	Reset Amount
CAPACTRL_StatCirA	AV	208	IR	RO	State of Circuit A
CAPACTRL_StatCirB	AV	209	IR	RO	State of Circuit B
CAPACTRL_viCmdA	AV	204	IR	RO	Comp. VI Cmd A
CAPACTRL_viCmdB	AV	205	IR	RO	Comp. VI Cmd B
CAPACTRL_xSpdHigh	AV	211	IR	RO	Transfer Spd, add cir
CAPACTRL_xSpdLow	AV	212	IR	RO	Transfer Spd, remove cir
CMP_PI_cpt_kp_a	AV	410		RO	Comp Temp PI, Kp Cir A
CMP_PI_cpt_kp_b	AV	425		RO	Comp Temp PI, Kp Cir B
CMP_PI_cpt_ni_a	AV	412		RO	Comp Temp PI, NI Cir A
CMP_PI_cpt_ni_b	AV	427		RO	Comp Temp PI, NI Cir B
CMP_PI_cpt_ti_a	AV	411		RO	Comp Temp PI, Ti Cir A
CMP_PI_cpt_ti_b	AV	426		RO	Comp Temp PI, Ti Cir B
CMP_PI_dgt_kp_a	AV	407		RO	DGT PI Kp, Cir A
CMP_PI_dgt_kp_b	AV	422		RO	DGT PI Kp, Cir B
CMP_PI_dgt_ni_a	AV	409		RO	DGT PI, NI Cir A
CMP_PI_dgt_ni_b	AV	424		RO	DGT PI, NI Cir B

LEGEND

AV — Analog Value	IR — Intrinsic Reporting
BV — Binary Value	RO — Read Only
CMD — Command	RW — Read Write
COV — Change of Value	TL — Trend Log

APPENDIX E — BACNET IP POINTS (cont)

OBJECT NAME	OBJECT TYPE	INSTANCE	OPTION	PV ACCESS	DESCRIPTION
CMP_Pi_dgt_ti_a	AV	408		RO	DGT PI, Ti Cir A
CMP_Pi_dgt_ti_b	AV	423		RO	DGT PI, Ti Cir B
CMP_Pi_dp_kp_a	AV	413		RO	Disch Press PI, Kp Cir A
CMP_Pi_dp_kp_b	AV	428		RO	Disch Press PI, Kp Cir B
CMP_Pi_dp_ni_a	AV	415		RO	Disch Press PI, NI Cir A
CMP_Pi_dp_ni_b	AV	430		RO	Disch Press PI, NI Cir B
CMP_Pi_dp_ti_a	AV	414		RO	Disch Press PI, Ti Cir A
CMP_Pi_dp_ti_b	AV	429		RO	Disch Press PI, Ti Cir B
CMP_Pi_ lsp_kp_a	AV	416		RO	Low SP PI, Kp Cir A
CMP_Pi_ lsp_kp_b	AV	431		RO	Low SP PI, Kp Cir B
CMP_Pi_ lsp_ni_a	AV	418		RO	Low SP PI, NI Cir A
CMP_Pi_ lsp_ni_b	AV	433		RO	Low SP PI, NI Cir B
CMP_Pi_ lsp_ti_a	AV	417		RO	Low SP PI, Ti Cir A
CMP_Pi_ lsp_ti_b	AV	432		RO	Low SP PI, Ti Cir B
CMP_Pi_wt_kp_a	AV	404		RO	Water Temp PI, Kp, Cir A
CMP_Pi_wt_kp_b	AV	419		RO	Water Temp PI, Kp, Cir B
CMP_Pi_wt_ni_a	AV	406		RO	Water Temp PI, NI Cir A
CMP_Pi_wt_ni_b	AV	421		RO	Water Temp PI, NI Cir B
CMP_Pi_wt_ti_a	AV	405		RO	Water Temp PI, Ti Cir A
CMP_Pi_wt_ti_b	AV	420		RO	Water Temp PI, Ti Cir B
CP_ENABL_en_cp_a	BV	121		RO	Compressor A Disable
CP_ENABL_en_cp_b	BV	122		RO	Compressor B Disable
DELTA_chdp_hys	AV	483		RO	cmp high dp hysteresis
DELTA_chdtact	AV	484		RO	cmp high dt act offset
DELTA_chtdspt	AV	485		RO	cmp high dt stp offset
DELTA_cramprt	AV	512		RO	Compressor Ramp Rate
DELTA_dgt_act	AV	503		RO	dgt limit act offset
DELTA_dgt_hyst	AV	502		RO	dgt hysteresis
DELTA_dgt_spt	AV	504		RO	dgt limit spt offset
DELTA_dsh_act	AV	506		RO	dsh act offset
DELTA_dsh_hyst	AV	505		RO	dsh hysteresis
DELTA_dshdelay	AV	507		RO	exv_no_dsh_delay
DELTA_fhdp_hys	AV	486		RO	fan high dp hysteresis
DELTA_fhdtact	AV	487		RO	fan high dt act offset
DELTA_fhdtstp	AV	488		RO	fan high dt stp offset
DELTA_hsp_hyst	AV	492		RO	high sp hysteresis
DELTA_hstdact	AV	493		RO	high st act offset
DELTA_hstdspt	AV	494		RO	high st stp offset
DELTA_ldp_hys	AV	489		RO	low dp hysteresis
DELTA_ldtdact	AV	490		RO	low dt act offset
DELTA_ldtdspt	AV	491		RO	low dt stp offset
DELTA_lsp_hyst	AV	495		RO	low sp hysteresis
DELTA_ilstact	AV	496		RO	low st act offset
DELTA_ilstdcpa	AV	498		RO	deltat IstEXV vs IstCAPA
DELTA_ilstdspt	AV	497		RO	low st stp offset
DELTA_mopdelay	AV	508		RO	exv_no_mop_delay
DELTA_mt_dact	AV	500		RO	motor temp act offset
DELTA_mt_dspt	AV	501		RO	motor temp stp offset

LEGEND

AV — Analog Value	IR — Intrinsic Reporting
BV — Binary Value	RO — Read Only
CMD — Command	RW — Read Write
COV — Change of Value	TL — Trend Log

APPENDIX E — BACNET IP POINTS (cont)

OBJECT NAME	OBJECT TYPE	INSTANCE	OPTION	PV ACCESS	DESCRIPTION
DELTA_mt_hyst	AV	499		RO	motor temp hysteresis
DELTA_sbc_act	AV	510		RO	subcool act offset
DELTA_sbc_hys	AV	509		RO	subcool hysteresis
DELTA_sbc_spt	AV	511		RO	Subcooling Setpoint A
DELTA_wateesys	AV	482		RO	water_t_hysteresis
ECO_CTRL_eco_a	AV	247		RO	EXV Eco Position Cir A
ECO_CTRL_eco_b	AV	248		RO	EXV Eco Position Cir B
ECO_Pi_capa_lim	AV	547		RO	Capacity Lim Disable Eco
ECO_Pi_eco_max	AV	546		RO	EXV Eco. Max Position
ECO_Pi_eco_min	AV	545		RO	EXV Eco. Min Position
ECO_Pi_ecoshspa	AV	548		RO	Eco Superheat Setpoint A
ECO_Pi_ecoshspb	AV	549		RO	Eco Superheat Setpoint B
ECO_Pi_ecsh_kpa	AV	539		RO	EXV Eco. SH Kp, Cir A
ECO_Pi_ecsh_kpb	AV	542		RO	EXV Eco. SH Kp, Cir B
ECO_Pi_ecsh_nia	AV	541		RO	EXV Eco. SH NI Cir A
ECO_Pi_ecsh_nib	AV	544		RO	EXV Eco. SH NI Cir B
ECO_Pi_ecsh_tia	AV	540		RO	EXV Eco. SH Ti Cir A
ECO_Pi_ecsh_tib	AV	543		RO	EXV Eco. SH Ti Cir B
EXV_CFG_apr_kp_a	AV	476		RO	Appr. PI, Kp Cir A
EXV_CFG_apr_kp_b	AV	479		RO	Appr. PI, Kp Cir B
EXV_CFG_apr_ni_a	AV	478		RO	Appr. PI, NI Cir A
EXV_CFG_apr_ni_b	AV	481		RO	Appr. PI, NI Cir B
EXV_CFG_apr_stp	AV	439		RO	Approach Setpoint
EXV_CFG_apr_ti_a	AV	477		RO	Appr. PI, Ti Cir A
EXV_CFG_apr_ti_b	AV	480		RO	Appr. PI, Ti Cir B
EXV_CFG_dop_kp_a	AV	452		RO	Dop PI, Kp Cir A
EXV_CFG_dop_kp_b	AV	470		RO	Dop PI, Kp Cir B
EXV_CFG_dop_ni_a	AV	454		RO	Dop PI, NI Cir A
EXV_CFG_dop_ni_b	AV	472		RO	Dop PI, NI Cir B
EXV_CFG_dop_ti_a	AV	453		RO	Dop PI, Ti Cir A
EXV_CFG_dop_ti_b	AV	471		RO	Dop PI, Ti Cir B
EXV_CFG_dsh_kp_a	AV	443		RO	DSH PI, Kp Cir A
EXV_CFG_dsh_kp_b	AV	461		RO	DSH PI, Kp Cir B
EXV_CFG_dsh_ni_a	AV	445		RO	DSH PI, NI Cir A
EXV_CFG_dsh_ni_b	AV	463		RO	DSH PI, NI Cir B
EXV_CFG_dsh_ti_a	AV	444		RO	DSH PI, Ti Cir A
EXV_CFG_dsh_ti_b	AV	462		RO	DSH PI, Ti Cir B
EXV_CFG_fixeddsh	AV	434		RO	Fixed DSH Setpoint
EXV_CFG_hsp_kp_a	AV	446		RO	High SP PI, Kp Cir A
EXV_CFG_hsp_kp_b	AV	464		RO	High SP PI, Kp Cir B
EXV_CFG_hsp_ni_a	AV	448		RO	High SP PI, NI Cir A
EXV_CFG_hsp_ni_b	AV	466		RO	High SP PI, NI Cir B
EXV_CFG_hsp_ti_a	AV	447		RO	High SP PI, Ti Cir A
EXV_CFG_hsp_ti_b	AV	465		RO	High SP PI, Ti Cir B
EXV_CFG_lsp_kp_a	AV	449		RO	Low SP PI, Kp Cir A
EXV_CFG_lsp_kp_b	AV	467		RO	Low SP PI, Kp Cir B
EXV_CFG_lsp_ni_a	AV	451		RO	Low SP PI, NI Cir A
EXV_CFG_lsp_ni_b	AV	469		RO	Low SP PI, NI Cir B

LEGEND

AV — Analog Value	IR — Intrinsic Reporting
BV — Binary Value	RO — Read Only
CMD — Command	RW — Read Write
COV — Change of Value	TL — Trend Log

APPENDIX E — BACNET IP POINTS (cont)

OBJECT NAME	OBJECT TYPE	INSTANCE	OPTION	PV ACCESS	DESCRIPTION
EXV_CFG_lsp_ti_a	AV	450		RO	Low SP PI, Ti Cir A
EXV_CFG_lsp_ti_b	AV	468		RO	Low SP PI, Ti Cir B
EXV_CFG_sbc_kp_a	AV	440		RO	Subcool PI, Kp Cir A
EXV_CFG_sbc_kp_b	AV	458		RO	Subcool PI, Kp Cir B
EXV_CFG_sbc_ni_a	AV	442		RO	Subcool PI, NI Cir A
EXV_CFG_sbc_ni_b	AV	460		RO	Subcool PI, NI Cir B
EXV_CFG_sbc_ti_a	AV	441		RO	Subcool PI, Ti Cir A
EXV_CFG_sbc_ti_b	AV	459		RO	Subcool PI, Ti Cir B
EXV_CFG_scsp_max	AV	435		RO	Subcooling Setpoint Max
EXV_CFG_scsp_min	AV	436		RO	Subcooling Setpoint Min
EXV_CFG_sh_sp_a	AV	437		RO	Superheat Setpoint A
EXV_CFG_sh_sp_b	AV	438		RO	Superheat Setpoint B
EXV_CFG_ssh_kp_a	AV	455		RO	Suction SH PI, Kp Cir A
EXV_CFG_ssh_kp_b	AV	473		RO	Suction SH PI, Kp Cir B
EXV_CFG_ssh_ni_a	AV	457		RO	Suction SH PI, NI Cir A
EXV_CFG_ssh_ni_b	AV	475		RO	Suction SH PI, NI Cir B
EXV_CFG_ssh_ti_a	AV	456		RO	Suction SH PI, Ti Cir A
EXV_CFG_ssh_ti_b	AV	474		RO	Suction SH PI, Ti Cir B
EXV_CTRL_DSH_A	AV	158		RO	Discharge Superheat A
EXV_CTRL_DSH_B	AV	170		RO	Discharge Superheat B
EXV_CTRL_dsh_spa	AV	159		RO	Dis. Superheat Setpnt A
EXV_CTRL_dsh_spb	AV	171		RO	Dis. Superheat Setpnt B
EXV_CTRL_EXV_A	AV	157		RO	EXV Position Circuit A
EXV_CTRL_EXV_B	AV	169		RO	EXV Position Circuit B
EXV_CTRL_exv_lsta	AV	166		RO	EXV Previous State A
EXV_CTRL_exv_lstb	AV	178		RO	EXV Previous State B
EXV_CTRL_exv_sta	AV	165		RO	EXV State A
EXV_CTRL_exv_stb	AV	177		RO	EXV State B
EXV_CTRL_exvwposa	AV	167		RO	EXV Wished Position A
EXV_CTRL_exvwposb	AV	179		RO	EXV Wished Position B
EXV_CTRL_ov_exv_a	AV	156		RO	EXV Override Circuit A
EXV_CTRL_ov_exv_b	AV	168		RO	EXV Override Circuit B
EXV_CTRL_pinch_a	AV	162		RO	Evap ExchangeDT Cir A
EXV_CTRL_pinch_b	AV	174		RO	Evap ExchangeDT Cir B
EXV_CTRL_SH_A	AV	160		RO	Suction Superheat A
EXV_CTRL_SH_B	AV	172		RO	Suction Superheat B
EXV_CTRL_sh_sp_a	AV	161		RO	Suct. Superheat Setpnt A
EXV_CTRL_sh_sp_b	AV	173		RO	Suct. Superheat Setpnt B
EXV_CTRL_subc_spa	AV	164		RO	Subcooling Setpoint A
EXV_CTRL_subc_spb	AV	176		RO	Subcooling Setpoint B
EXV_CTRL_subcoola	AV	163		RO	Subcooling Circuit A
EXV_CTRL_subcoolb	AV	175		RO	Subcooling Circuit B
FACTORY_cpass_nb	AV	323		RO	Evap Pass Number
FACTORY_emm_nrcp	BV	100		RO	Energy Management Module
FACTORY_fac_pass	AV	324		RO	Factory Password
FACTORY_fan_fact	AV	327		RO	Fan Freq Factor(0.7-1.1)
FACTORY_fMaxEnA	BV	103		RO	Enable Max Frequency A
FACTORY_fMaxEnB	BV	104		RO	Enable Max Frequency B

LEGEND

AV — Analog Value	IR — Intrinsic Reporting
BV — Binary Value	RO — Read Only
CMD — Command	RW — Read Write
COV — Change of Value	TL — Trend Log

APPENDIX E — BACNET IP POINTS (cont)

OBJECT NAME	OBJECT TYPE	INSTANCE	OPTION	PV ACCESS	DESCRIPTION
FACTORY_fMaxOvrA	AV	325		RO	Max Frequency Override A
FACTORY_fMaxOvrB	AV	326		RO	Max Frequency Override B
FACTORY_fMinOvr	AV	328		RO	Min Frequency Override
FACTORY_freq_60H	BV	96		RO	60Hz Sel (No=50, Yes=60)
FACTORY_heat_sel	BV	98		RO	Evap Heater Installed
FACTORY_lastspda	AV	329		RO	Low Amb. Start Spd A
FACTORY_lastspdb	AV	330		RO	Low Amb. Start Spd B
FACTORY_leak_chk	BV	102		RO	Leakage Charge Detection
FACTORY_loambopt	BV	101		RO	Low Ambient Option (STD)
FACTORY_mfg_tier	AV	322		RO	Tier 0=STD, 1=MID, 2=HI
FACTORY_mst_slv	BV	99		RO	Master Slave Setup
FACTORY_probrine	BV	97		RO	Process Brine Evap
FACTORY_unitsize	AV	320		RO	Unit Capacity
FACTORY_voltage	AV	321		RO	Power Supply Voltage
FACTORY2_eco_cnfa	AV	333		RO	Economizer A Steps Numb
FACTORY2_eco_cnfba	AV	334		RO	Economizer B Steps Numb
FACTORY2_exvmax_a	AV	331		RO	EXV A Maximum Steps Numb
FACTORY2_exvmax_b	AV	332		RO	EXV B Maximum Steps Numb
FACTORY2_vfd_cmp	AV	335		RO	Nb VFD Compressor
FACTORY2_vfd_fana	AV	336		RO	Nb Fan Drive Cir A
FACTORY2_vfd_fanb	AV	337		RO	Nb Fan Drive Cir B
FAN_CFG_cp_factA	AV	527		RO	Compressor Factor A
FAN_CFG_cp_factB	AV	528		RO	Compressor Factor B
FAN_CFG_fan_ctrl	BV	119		RO	Fan Ctrl Type (Vari,Fix), Optimization Parameters
FAN_CFG_fan_hlim	AV	522		RO	Fan Max Frequency
FAN_CFG_fan_llim	AV	523		RO	Fan Min Frequency
FAN_CFG_fldp_kpa	AV	516		RO	Fan Low DP PI, Kp, Cir A
FAN_CFG_fldp_kpb	AV	519		RO	Fan Low DP PI, Kp, Cir B
FAN_CFG_fldp_nia	AV	518		RO	Fan Low DP PI, NI Cir A
FAN_CFG_fldp_nib	AV	521		RO	Fan Low DP PI, NI Cir B
FAN_CFG_fldp_tia	AV	517		RO	Fan Low DP PI, Ti Cir A
FAN_CFG_fldp_tib	AV	520		RO	Fan Low DP PI, Ti Cir B
FAN_CFG_fldtfact	AV	529		RO	Fan Low Dis. Factor
FAN_CFG_n_coilsA	AV	525		RO	Cir Cond Coil Number A
FAN_CFG_n_coilsB	AV	526		RO	Cir Cond Coil Number B
FAN_CFG_os_d_amp	AV	532		RO	Opt. Disturbance Ampl.
FAN_CFG_os_d_per	AV	533		RO	Opt. Disturbance Period
FAN_CFG_os_f_pow	AV	534		RO	Opt. Freeze Power Tol.
FAN_CFG_sct_bias	AV	536		RO	SCT bias at start
FAN_CFG_sct_decr	AV	538		RO	Decrement SCT bias time
FAN_CFG_sct_tim	AV	537		RO	Total SCT bias time
FAN_CFG_sync_Kp	AV	524		RO	Synchronizing Output Kp
FAN_CFG_xt_enabl	BV	120		RO	Optimization Enable
FAN_CFG_xt_in_tl	AV	531		RO	Opt. Deviation Tolerance
FAN_CFG_xt_s_smp	AV	530		RO	Stability Sample Nb
FAN_CFG_xtosflt	AV	535		RO	Opt. Filter Time
FAN_CTRL_fan_f_a	AV	249	IR	RO	Fan Freq Cir A
FAN_CTRL_fan_f_b	AV	257	IR	RO	Fan Freq Cir B

LEGEND

AV — Analog Value	IR — Intrinsic Reporting
BV — Binary Value	RO — Read Only
CMD — Command	RW — Read Write
COV — Change of Value	TL — Trend Log

APPENDIX E — BACNET IP POINTS (cont)

OBJECT NAME	OBJECT TYPE	INSTANCE	OPTION	PV ACCESS	DESCRIPTION
FAN_CTRL_fan_1sta	AV	251	IR	RO	Fan Previous State A
FAN_CTRL_fan_1stb	AV	259	IR	RO	Fan Previous State B
FAN_CTRL_fan_moda	AV	253	IR	RO	Fan Mode A
FAN_CTRL_fan_modb	AV	261	IR	RO	Fan Mode B
FAN_CTRL_fan_sta	AV	250	IR	RO	Fan State A
FAN_CTRL_fan_stb	AV	258	IR	RO	Fan State B
FAN_CTRL_fan_txta	AV	254	IR	RO	Fan Mode Text A
FAN_CTRL_fan_txtb	AV	262	IR	RO	Fan Mode Text B
FAN_CTRL_fcont_a	AV	256	IR	RO	Fan Contactors On A
FAN_CTRL_fcont_b	AV	264	IR	RO	Fan Contactors On B
FAN_CTRL_ftotpowa	AV	255	IR	RO	Fan Tot Pwr Filtered A
FAN_CTRL_ftotpowb	AV	263	IR	RO	Fan Tot Pwr Filtered B
FAN_CTRL_wfan_f_a	AV	252	IR	RO	Fan Wished Freq A
FAN_CTRL_wfan_f_b	AV	260	IR	RO	Fan Wished Freq B
FAN_DRV_fd_CCTa1	AV	273	IR	RO	Fan Drive Ctrl Card T A1
FAN_DRV_fd_CCTa2	AV	282	IR	RO	Fan Drive Ctrl Card T A2
FAN_DRV_fd_CCTa3	AV	291	IR	RO	Fan Drive Ctrl Card T A3
FAN_DRV_fd_CCTb1	AV	300	IR	RO	Fan Drive Ctrl Card T B1
FAN_DRV_fd_CCTb2	AV	309	IR	RO	Fan Drive Ctrl Card T B2
FAN_DRV_fd_CCTb3	AV	318	IR	RO	Fan Drive Ctrl Card T B3
FAN_DRV_fd_DCVa1	AV	271	IR	RO	Fan Drv DC Link Volt A1
FAN_DRV_fd_DCVa2	AV	280	IR	RO	Fan Drv DC Link Volt A2
FAN_DRV_fd_DCVa3	AV	289	IR	RO	Fan Drv DC Link Volt A3
FAN_DRV_fd_DCVb1	AV	298	IR	RO	Fan Drv DC Link Volt B1
FAN_DRV_fd_DCVb2	AV	307	IR	RO	Fan Drv DC Link Volt B2
FAN_DRV_fd_DCVb3	AV	316	IR	RO	Fan Drv DC Link Volt B3
FAN_DRV_fd_Fa1	AV	269	IR	RO	Fan Drive Frequency A1
FAN_DRV_fd_Fa2	AV	278	IR	RO	Fan Drive Frequency A2
FAN_DRV_fd_Fa3	AV	287	IR	RO	Fan Drive Frequency A3
FAN_DRV_fd_Fb1	AV	296	IR	RO	Fan Drive Frequency B1
FAN_DRV_fd_Fb2	AV	305	IR	RO	Fan Drive Frequency B2
FAN_DRV_fd_Fb3	AV	314	IR	RO	Fan Drive Frequency B3
FAN_DRV_fd_HSTa1	AV	272	IR	RO	Fan Drive Heat Sink T A1
FAN_DRV_fd_HSTa2	AV	281	IR	RO	Fan Drive Heat Sink T A2
FAN_DRV_fd_HSTa3	AV	290	IR	RO	Fan Drive Heat Sink T A3
FAN_DRV_fd_HSTb1	AV	299	IR	RO	Fan Drive Heat Sink T B1
FAN_DRV_fd_HSTb2	AV	308	IR	RO	Fan Drive Heat Sink T B2
FAN_DRV_fd_HSTb3	AV	317	IR	RO	Fan Drive Heat Sink T B3
FAN_DRV_fd_la1	AV	266	IR	RO	Fan Drive Amps A1
FAN_DRV_fd_la2	AV	275	IR	RO	Fan Drive Amps A2
FAN_DRV_fd_la3	AV	284	IR	RO	Fan Drive Amps A3
FAN_DRV_fd_lb1	AV	293	IR	RO	Fan Drive Amps B1
FAN_DRV_fd_lb2	AV	302	IR	RO	Fan Drive Amps B2
FAN_DRV_fd_lb3	AV	311	IR	RO	Fan Drive Amps B3
FAN_DRV_fd_pwr	AV	319	IR	RO	Total Fan Drive Power
FAN_DRV_fd_pwra1	AV	265	IR	RO	Fan Drive Power A1
FAN_DRV_fd_pwra2	AV	274	IR	RO	Fan Drive Power A2
FAN_DRV_fd_pwra3	AV	283	IR	RO	Fan Drive Power A3

LEGEND

AV — Analog Value	IR — Intrinsic Reporting
BV — Binary Value	RO — Read Only
CMD — Command	RW — Read Write
COV — Change of Value	TL — Trend Log

APPENDIX E — BACNET IP POINTS (cont)

OBJECT NAME	OBJECT TYPE	INSTANCE	OPTION	PV ACCESS	DESCRIPTION
FAN_DRV_fd_pwrB1	AV	292	IR	RO	Fan Drive Power B1
FAN_DRV_fd_pwrB2	AV	301	IR	RO	Fan Drive Power B2
FAN_DRV_fd_pwrB3	AV	310	IR	RO	Fan Drive Power B3
FAN_DRV_fd_Sa1	AV	268	IR	RO	Fan Drive Speed A1
FAN_DRV_fd_Sa2	AV	277	IR	RO	Fan Drive Speed A2
FAN_DRV_fd_Sa3	AV	286	IR	RO	Fan Drive Speed A3
FAN_DRV_fd_Sb1	AV	295	IR	RO	Fan Drive Speed B1
FAN_DRV_fd_Sb2	AV	304	IR	RO	Fan Drive Speed B2
FAN_DRV_fd_Sb3	AV	313	IR	RO	Fan Drive Speed B3
FAN_DRV_fd-Ta1	AV	270	IR	RO	Fan Drive Torque A1
FAN_DRV_fd-Ta2	AV	279	IR	RO	Fan Drive Torque A2
FAN_DRV_fd-Ta3	AV	288	IR	RO	Fan Drive Torque A3
FAN_DRV_fd-Tb1	AV	297	IR	RO	Fan Drive Torque B1
FAN_DRV_fd-Tb2	AV	306	IR	RO	Fan Drive Torque B2
FAN_DRV_fd-Tb3	AV	315	IR	RO	Fan Drive Torque B3
FAN_DRV_fd_Va1	AV	267	IR	RO	Fan Drive Voltage A1
FAN_DRV_fd_Va2	AV	276	IR	RO	Fan Drive Voltage A2
FAN_DRV_fd_Va3	AV	285	IR	RO	Fan Drive Voltage A3
FAN_DRV_fd_Vb1	AV	294	IR	RO	Fan Drive Voltage B1
FAN_DRV_fd_Vb2	AV	303	IR	RO	Fan Drive Voltage B2
FAN_DRV_fd_Vb3	AV	312	IR	RO	Fan Drive Voltage B3
FAN_DRV2_FD_COMA1	BV	88	IR	RO	Comm Fan Drive A1 Ok
FAN_DRV2_FD_COMA2	BV	89	IR	RO	Comm Fan Drive A2 Ok
FAN_DRV2_FD_COMA3	BV	90	IR	RO	Comm Fan Drive A3 Ok
FAN_DRV2_FD_COMB1	BV	91	IR	RO	Comm Fan Drive B1 Ok
FAN_DRV2_FD_COMB2	BV	92	IR	RO	Comm Fan Drive B2 Ok
FAN_DRV2_FD_COMB3	BV	93	IR	RO	Comm Fan Drive B3 Ok
FAN_DRV2_SET_FDA1	BV	82	IR	RO	Fan Drive A1 Attach
FAN_DRV2_SET_FDA2	BV	83	IR	RO	Fan Drive A2 Attach
FAN_DRV2_SET_FDA3	BV	84	IR	RO	Fan Drive A3 Attach
FAN_DRV2_SET_FDB1	BV	85	IR	RO	Fan Drive B1 Attach
FAN_DRV2_SET_FDB2	BV	86	IR	RO	Fan Drive B2 Attach
FAN_DRV2_SET_FDB3	BV	87	IR	RO	Fan Drive B3 Attach
FAN_DRV2_stopfana	BV	94	IR	RO	Stop Cir A Fan Drive
FAN_DRV2_stopfanb	BV	95	IR	RO	Stop Cir B Fan Drive
GENCONF_ice_cnfg	BV	2		RO	Ice Mode Enable
GENCONF_lim_sel	AV	3		RO	Demand Limit Type Select, 0 = None, 1 = Switch Control, 2 = 4-20mA Control
GENCONF_nh_end	AV	5		RO	Night Mode End Hour
GENCONF_nh_limit	AV	6		RO	Night Capacity Limit
GENCONF_nh_start	AV	4		RO	Night Mode Start Hour
GENCONF_off_on_d	AV	2		RO	Unit Off to On Delay
GENCONF_prio_cir	AV	1		RO	Cir Priority Sequence 0=Auto, 1=A Prio 2=B Prio
GENCONF_ramp_sel	BV	1		RO	Ramp Loading Enable
GENCONF_shortcyc	BV	3		RO	Short Cycle Management
GENUNIT_CAP_T	AV	24	COV IR	RO	Percent Total Capacity
GENUNIT_CHIL_OCC_rd	BV	7	IR	RO	Net.: Cmd Occupied
GENUNIT_CHIL_OCC_wr	BV	129	IR CMD	RW	Net.: Cmd Occupied
GENUNIT_CHIL_S_S_rd	BV	6		RO	Net.: Cmd Start/Stop

LEGEND

AV — Analog Value	IR — Intrinsic Reporting
BV — Binary Value	RO — Read Only
CMD — Command	RW — Read Write
COV — Change of Value	TL — Trend Log

APPENDIX E — BACNET IP POINTS (cont)

OBJECT NAME	OBJECT TYPE	INSTANCE	OPTION	PV ACCESS	DESCRIPTION
GENUNIT_CHIL_S_S_wr	BV	123	IR CMD	RW	Net.: Cmd Start/Stop
GENUNIT_CTRL_PNT_rd	AV	26	COV IR	RO	Control Point
GENUNIT_CTRL_PNT_wr	AV	557	IR CMD	RW	Control Point
GENUNIT_CTRL_TYP	AV	20	IR	RO	Local=0 Net.=1 Remote=2
GENUNIT_DEM_LIM_rd	AV	27		RO	Active Demand Limit Val
GENUNIT_DEM_LIM_wr	AV	558	IR CMD	RW	Active Demand Limit Val
GENUNIT_EMSTOP_rd	BV	9		RO	Emergency Stop
GENUNIT_EMSTOP_wr	BV	126	IR CMD	RW	Emergency Stop
GENUNIT_min_left	AV	22		RO	Minutes Left for Start
GENUNIT_min_lim	AV	28		RO	Demand Limit Minimum
GENUNIT_SP	AV	25		RO	Current Setpoint
GENUNIT_SP_OCC_rd	BV	8		RO	Setpoint Occupied?
GENUNIT_SP_OCC_wr	BV	128	IR CMD	RW	Setpoint Occupied?
GENUNIT_SP_SEL_rd	AV	23		RO	Setpoint Select, 0=Auto, 1=Spt1, 2=Spt2
GENUNIT_SP_SEL_wr	AV	559	IR CMD	RW	Setpoint Select
GENUNIT_STATUS	AV	21	COV IR	RO	Run Status
INPUTS_HEATR_SW	BV	19	IR	RO	Evap Heater Detector
INPUTS_ICE_SW	BV	17	IR	RO	Ice Done Storage Switch
INPUTS_leak_2_v	AV	65	IR	RO	Leakage Detector 2
INPUTS_leak_v	AV	64	IR	RO	Leakage Detector 1
INPUTS_LIM_ANAL	AV	63	IR	RO	Remote Dem. Limit
INPUTS_LIM_SW1	BV	12	IR	RO	Limit Switch 1
INPUTS_LIM_SW2	BV	13	IR	RO	Limit Switch 2
INPUTS_OCC_OVSW	BV	18	IR	RO	Occupied Override Switch
INPUTS_OIL_L_A	BV	14	IR	RO	Oil Level Input A
INPUTS_OIL_L_B	BV	15	IR	RO	Oil Level Input B
INPUTS_ONOFF_SW	BV	10	IR	RO	Remote On/Off Switch
INPUTS_REM_LOCK	BV	16	IR	RO	Customer Interlock
INPUTS_SETP_SW	BV	11	IR	RO	Remote Setpoint Switch
INPUTS_SP_RESET	AV	62	IR	RO	Remote Reset Setpoint
LAST_POR_date_of1	AV	138	IR	RO	PowerDown 1:day-mon-year
LAST_POR_date_of2	AV	142	IR	RO	PowerDown 2:day-mon-year
LAST_POR_date_of3	AV	146	IR	RO	PowerDown 3:day-mon-year
LAST_POR_date_of4	AV	150	IR	RO	PowerDown 4:day-mon-year
LAST_POR_date_of5	AV	154	IR	RO	PowerDown 5:day-mon-year
LAST_POR_date_on1	AV	136	IR	RO	Power On 1 :day-mon-year
LAST_POR_date_on2	AV	140	IR	RO	Power On 2 :day-mon-year
LAST_POR_date_on3	AV	144	IR	RO	Power On 3 :day-mon-year
LAST_POR_date_on4	AV	148	IR	RO	Power On 4 :day-mon-year
LAST_POR_date_on5	AV	152	IR	RO	Power On 5 :day-mon-year
LAST_POR_time_of1	AV	139	IR	RO	PowerDown 1:hour-minute
LAST_POR_time_of2	AV	143	IR	RO	PowerDown 2:hour-minute
LAST_POR_time_of3	AV	147	IR	RO	PowerDown 3:hour-minute
LAST_POR_time_of4	AV	151	IR	RO	PowerDown 4:hour-minute
LAST_POR_time_of5	AV	155	IR	RO	PowerDown 5:hour-minute
LAST_POR_time_on1	AV	137	IR	RO	Power On 1 :hour-minute
LAST_POR_time_on2	AV	141	IR	RO	Power On 2 :hour-minute
LAST_POR_time_on3	AV	145	IR	RO	Power On 3 :hour-minute

LEGEND

AV — Analog Value	IR — Intrinsic Reporting
BV — Binary Value	RO — Read Only
CMD — Command	RW — Read Write
COV — Change of Value	TL — Trend Log

APPENDIX E — BACNET IP POINTS (cont)

OBJECT NAME	OBJECT TYPE	INSTANCE	OPTION	PV ACCESS	DESCRIPTION
LAST_POR_time_on4	AV	149	IR	RO	Power On 4 :hour-minute
LAST_POR_time_on5	AV	153	IR	RO	Power On 5 :hour-minute
LIMITS_chdpacta	AV	217	IR	RO	ENV comp high dp act A
LIMITS_chdpactb	AV	234	IR	RO	ENV comp high dp act B
LIMITS_chdpstpa	AV	218	IR	RO	ENV comp high dp stp A
LIMITS_chdpstpb	AV	235	IR	RO	ENV comp high dp stp B
LIMITS_dgtacta	AV	228	IR	RO	dgt act A
LIMITS_dgtactb	AV	245	IR	RO	dgt_act B
LIMITS_dgtstpa	AV	229	IR	RO	dgt stp A
LIMITS_dgtstpb	AV	246	IR	RO	dgt_stp B
LIMITS_dshacta	AV	213	IR	RO	EXV_dsh_act A
LIMITS_dshactb	AV	230	IR	RO	EXV_dsh_act B
LIMITS_dshstpa	AV	214	IR	RO	EXV_dsh_stp A
LIMITS_dshstpb	AV	231	IR	RO	EXV_dsh_stp B
LIMITS_elspacta	AV	215	IR	RO	EXV_lsp_act A
LIMITS_elspactb	AV	232	IR	RO	EXV_lsp_act B
LIMITS_elspstpa	AV	216	IR	RO	EXV_lsp_stp A
LIMITS_elspstpb	AV	233	IR	RO	EXV_lsp_stp B
LIMITS_fhdpacta	AV	219	IR	RO	ENV fan high dp act A
LIMITS_fhdpactb	AV	236	IR	RO	ENV fan high dp act B
LIMITS_fhdpstpa	AV	220	IR	RO	ENV fan high dp stp A
LIMITS_fhdpstpb	AV	237	IR	RO	ENV fan high dp stp B
LIMITS_hspacta	AV	223	IR	RO	ENV high sp act A
LIMITS_hspactb	AV	240	IR	RO	ENV high sp act B
LIMITS_hspstpa	AV	224	IR	RO	ENV high sp stp A
LIMITS_hspstpb	AV	241	IR	RO	ENV high sp stp B
LIMITS_ldpacta	AV	221	IR	RO	ENV low dp act A
LIMITS_ldpactb	AV	238	IR	RO	ENV low dp act B
LIMITS_ldpstpa	AV	222	IR	RO	ENV low dp stp A
LIMITS_ldpstpb	AV	239	IR	RO	ENV low dp stp B
LIMITS_lspacta	AV	225	IR	RO	ENV low sp act A
LIMITS_lspactb	AV	242	IR	RO	ENV low sp act B
LIMITS_lspdcpa	AV	227	IR	RO	ENV low sp delta A
LIMITS_lspdcpb	AV	244	IR	RO	ENV low sp delta B
LIMITS_lspstpa	AV	226	IR	RO	ENV low sp stp A
LIMITS_lspstpb	AV	243	IR	RO	ENV low sp stp B
M_MSTSLV_cap_max	BV	81		RO	Max Available Capacity ?
M_MSTSLV_l_strt_d	AV	182		RO	Lag Start Delay
M_MSTSLV_lagstat	AV	185		RO	Slave lagstat
M_MSTSLV_lead_sel	BV	78		RO	Lead Unit is the:
M_MSTSLV_ll_chang	BV	79		RO	Lead/lag Changeover?
M_MSTSLV_ll_hr_d	AV	183		RO	Lead/lag Hours Delta
M_MSTSLV_ll_pull	BV	80		RO	Lead Pulldown ?
M_MSTSLV_ms_activ	BV	77		RO	Master/Slave Ctrl Active
M_MSTSLV_ms_error	AV	184		RO	Master/Slave Error
M_MSTSLV_slav_ewt	AV	187		RO	Slave Evap Ent. Fluid
M_MSTSLV_slav_hr	AV	186		RO	Slave Operating Hours
M_MSTSLV_slav_lwt	AV	188		RO	Slave Evap Leav. Fluid

LEGEND

AV — Analog Value	IR — Intrinsic Reporting
BV — Binary Value	RO — Read Only
CMD — Command	RW — Read Write
COV — Change of Value	TL — Trend Log

APPENDIX E — BACNET IP POINTS (cont)

OBJECT NAME	OBJECT TYPE	INSTANCE	OPTION	PV ACCESS	DESCRIPTION
M_MSTSLV_slv_capt	AV	181		RO	Slave Chiller Total Cap
M_MSTSLV_slv_stat	AV	180		RO	Slave Chiller State
MODES_m_2stpt	BV	64	IR	RO	Second Setpoint In Use
MODES_m_delay	BV	63	IR	RO	Start Up Delay In Effect
MODES_m_demlim	BV	66	IR	RO	Demand Limit Active
MODES_m_ice	BV	71	IR	RO	Ice Mode In Effect, Active Alarms:
MODES_m_night	BV	69	IR	RO	Night Low Noise Active
MODES_m_pmpper	BV	68	IR	RO	Pump Periodic Start
MODES_m_pmprot	BV	67	IR	RO	Evaporator Pump Rotation
MODES_m_reset	BV	65	IR	RO	Reset In Effect
MODES_m_slave	BV	70	IR	RO	Master Slave Active
MST_SLV_lag_mini	AV	402		RO	Lag Minimum Running Time
MST_SLV_lag_pump	AV	403		RO	Lag Unit Pump Control, 0=Stop if Unit Stops, 1=Run if Unit Stops
MST_SLV_lead_pul	AV	400		RO	Lead Pulldown Time
MST_SLV_lead_sel	AV	397		RO	Lead Lag Select, 0=Always Lead, 1=Lag Once Failed Only, 2=Lead/Lag Runtime Sel
MST_SLV_ll_bal_d	AV	398		RO	Lead/Lag Balance Delta
MST_SLV_ll_serie	BV	116		RO	Chiller In Series
MST_SLV_lstr_tim	AV	399		RO	Lead/Lag Start Timer
MST_SLV_ms_ctrl	AV	395		RO	Master Control Type, 1=Local Control, 2=Remote Control, 3=CCN Control
MST_SLV_ms_sel	AV	394		RO	Master/Slave Select, 0=Disable, 1=Master, 2=Slave
MST_SLV_slv_addr	AV	396		RO	Slave Address
MST_SLV_start_dt	AV	401		RO	Start If Error Higher
OUTPUTS_ALARM	BV	34	IR	RO	Alarm Relay Status
OUTPUTS_ALERT	BV	36	IR	RO	Alert Relay State
OUTPUTS_BOX_HTR	BV	57	IR	RO	Control Box Heater
OUTPUTS_C_HEATER	BV	38	IR	RO	Evap Heater Output
OUTPUTS_CAPT_010	AV	70	IR	RO	Chiller Capacity Signal
OUTPUTS_CAPT010A	AV	66	IR	RO	Capacity Signal Cir A
OUTPUTS_CAPT010B	AV	68	IR	RO	Capacity Signal Cir B
OUTPUTS_CP_A	BV	21	IR	RO	Compressor A
OUTPUTS_CP_B	BV	28	IR	RO	Compressor B
OUTPUTS_FCA1	BV	39	IR	RO	Fan Contactor 1A
OUTPUTS_FCA2	BV	40	IR	RO	Fan Contactor 2A
OUTPUTS_FCA3	BV	41	IR	RO	Fan Contactor 3A
OUTPUTS_FCA4	BV	42	IR	RO	Fan Contactor 4A
OUTPUTS_FCA5	BV	43	IR	RO	Fan Contactor 5A
OUTPUTS_FCA6	BV	44	IR	RO	Fan Contactor 6A
OUTPUTS_FCA7	BV	45	IR	RO	Fan Contactor 7A
OUTPUTS_FCA8	BV	46	IR	RO	Fan Contactor 8A
OUTPUTS_FCB1	BV	47	IR	RO	Fan Contactor 1B
OUTPUTS_FCB2	BV	48	IR	RO	Fan Contactor 2B
OUTPUTS_FCB3	BV	49	IR	RO	Fan Contactor 3B
OUTPUTS_FCB4	BV	50	IR	RO	Fan Contactor 4B
OUTPUTS_FCB5	BV	51	IR	RO	Fan Contactor 5B
OUTPUTS_FCB6	BV	52	IR	RO	Fan Contactor 6B

LEGEND

AV — Analog Value	IR — Intrinsic Reporting
BV — Binary Value	RO — Read Only
CMD — Command	RW — Read Write
COV — Change of Value	TL — Trend Log

APPENDIX E — BACNET IP POINTS (cont)

OBJECT NAME	OBJECT TYPE	INSTANCE	OPTION	PV ACCESS	DESCRIPTION
OUTPUTS_FCB7	BV	53	IR	RO	Fan Contactor 7B
OUTPUTS_FCB8	BV	54	IR	RO	Fan Contactor 8B
OUTPUTS_ISO_OP_A	BV	24	IR	RO	Ref Iso Relay Energize A
OUTPUTS_ISO_OP_B	BV	31	IR	RO	Ref Iso Relay Energize B
OUTPUTS_ISO_POSA	BV	25	IR	RO	Ref Iso Valve State A
OUTPUTS_ISO_POSB	BV	32	IR	RO	Ref Iso Valve State B
OUTPUTS_LABEL_A	BV	20	IR	RO	CIRCUIT A
OUTPUTS_LABEL_B	BV	27	IR	RO	CIRCUIT B
OUTPUTS_OIL_HT_A	BV	26	IR	RO	Oil Heater Output A
OUTPUTS_OIL_HT_B	BV	33	IR	RO	Oil Heater Output B
OUTPUTS_OIL_SL_A	BV	22	IR	RO	Oil Solenoid Output A
OUTPUTS_OIL_SL_B	BV	29	IR	RO	Oil Solenoid Output B
OUTPUTS_RUNNING	BV	35	IR	RO	Running Relay Status
OUTPUTS_SHUTDOWN	BV	37	IR	RO	Shutdown Indicator State
OUTPUTS_VFAN_A	AV	67	IR	RO	VariFan Speed A
OUTPUTS_VFAN_B	AV	69	IR	RO	VariFan Speed B
OUTPUTS_VFD_EN_A	BV	55	IR	RO	Comp. HW Enable A
OUTPUTS_VFD_EN_B	BV	56	IR	RO	Comp. HW Enable B
OUTPUTS_VI_A	BV	23	IR	RO	VI Solenoid Output A
OUTPUTS_VI_B	BV	30	IR	RO	VI Solenoid Output B
PRESSURE_DOP_A	AV	53	COV IR	RO	Delta Oil Pressure A
PRESSURE_DOP_B	AV	59	COV IR	RO	Delta Oil Pressure B
PRESSURE_DP_A	AV	50	COV IR	RO	Discharge Pressure A
PRESSURE_DP_B	AV	56	COV IR	RO	Discharge Pressure B
PRESSURE_ECO_P_A	AV	54	COV IR	RO	Economizer Pressure A
PRESSURE_ECO_P_B	AV	60	COV IR	RO	Economizer Pressure B
PRESSURE_LIQ_P_A	AV	55	COV IR	RO	Liquid Pressure A
PRESSURE_LIQ_P_B	AV	61	COV IR	RO	Liquid Pressure B
PRESSURE_OP_A	AV	52	COV IR	RO	Oil Pressure A
PRESSURE_OP_B	AV	58	COV IR	RO	Oil Pressure B
PRESSURE_SP_A	AV	51	COV IR	RO	Main Suction Pressure A
PRESSURE_SP_B	AV	57	COV IR	RO	Main Suction Pressure B
PUMPCONF_cpumpseq	AV	7		RO	Evap Pumps Sequence, 0 = No Pump, 1 = One Pump Only, 2 = Two Pumps Auto, 3 = Pump#1 Manual, 4 = Pump#2 Manual
PUMPCONF_pump_del	AV	8		RO	Pump Auto Rotation Delay
PUMPCONF_pump_loc	BV	5		RO	Flow Checked If Pump Off
PUMPCONF_pump_per	BV	4		RO	Pump Sticking Protection
PUMPSTAT_CPUMP_1_rd	BV	58	IR	RO	Evap Pump #1 Command
PUMPSTAT_CPUMP_1_wr	BV	124	IR CMD	RW	Evap Pump #1 Command
PUMPSTAT_CPUMP_2_rd	BV	59	IR	RO	Evap Pump #2 Command
PUMPSTAT_CPUMP_2_wr	BV	125	IR CMD	RW	Evap Pump #2 Command
PUMPSTAT_FLOW_SW	BV	61	IR	RO	Evap Flow Switch #1
PUMPSTAT_FLOW_SWB	BV	62	IR	RO	Evap Flow Switch #2
PUMPSTAT_ROTCPUMP_rd	BV	60	IR	RO	Rotate Evap Pumps ?
PUMPSTAT_ROTCPUMP_wr	BV	127	IR CMD	RW	Rotate Evap Pumps ?
RESETCFG_cr_deg	AV	19		RO	Cooling Reset Deg. Value
RESETCFG_cr_sel	AV	10		RO	Cooling Reset Select, 0=None, 1=OAT, 2=Delta T, 3=4-20mA control, Cooling Reset Select, 4=Space Temp

LEGEND

AV — Analog Value	IR — Intrinsic Reporting
BV — Binary Value	RO — Read Only
CMD — Command	RW — Read Write
COV — Change of Value	TL — Trend Log

APPENDIX E — BACNET IP POINTS (cont)

OBJECT NAME	OBJECT TYPE	INSTANCE	OPTION	PV ACCESS	DESCRIPTION
RESETCFG_dt_cr_fu	AV	14		RO	Delta T Full Reset Value
RESETCFG_dt_cr_no	AV	13		RO	Delta T No Reset Value
RESETCFG_oat_crfu	AV	12		RO	OAT Full Reset Value
RESETCFG_oat_cmo	AV	11		RO	OAT No Reset Value
RESETCFG_spacr_fu	AV	18		RO	Space T Full Reset Value
RESETCFG_spacr_no	AV	17		RO	Space T No Reset Value
RESETCFG_v_cr_fu	AV	16		RO	Current Full Reset Value
RESETCFG_v_cr_no	AV	15		RO	Current No Reset Value
RUNTIME_HR_CP_A	AV	73	IR	RO	Compressor A Hours
RUNTIME_HR_CP_B	AV	75	IR	RO	Compressor B Hours
RUNTIME_hr_cpum1	AV	77	IR	RO	Evap Pump #1 Hours
RUNTIME_hr_cpum2	AV	78	IR	RO	Evap Pump #2 Hours
RUNTIME_HR_MACH	AV	71	IR	RO	Machine Operating Hours
RUNTIME_hrfana01	AV	81	IR	RO	Circuit A Fan #1 Hours
RUNTIME_hrfana02	AV	82	IR	RO	Circuit A Fan #2 Hours
RUNTIME_hrfana03	AV	83	IR	RO	Circuit A Fan #3 Hours
RUNTIME_hrfana04	AV	84	IR	RO	Circuit A Fan #4 Hours
RUNTIME_hrfana05	AV	85	IR	RO	Circuit A Fan #5 Hours
RUNTIME_hrfana06	AV	86	IR	RO	Circuit A Fan #6 Hours
RUNTIME_hrfana07	AV	87	IR	RO	Circuit A Fan #7 Hours
RUNTIME_hrfana08	AV	88	IR	RO	Circuit A Fan #8 Hours
RUNTIME_hrfana09	AV	89	IR	RO	Circuit A Fan #9 Hours
RUNTIME_hrfana10	AV	90	IR	RO	Circuit A Fan #10 Hours
RUNTIME_hrfana11	AV	91	IR	RO	Circuit A Fan #11 Hours
RUNTIME_hrfana12	AV	92	IR	RO	Circuit A Fan #12 Hours
RUNTIME_hrfana13	AV	93	IR	RO	Circuit A Fan #13 Hours
RUNTIME_hrfana14	AV	94	IR	RO	Circuit A Fan #14 Hours
RUNTIME_hrfanb01	AV	95	IR	RO	Circuit B Fan #1 Hours
RUNTIME_hrfanb02	AV	96	IR	RO	Circuit B Fan #2 Hours
RUNTIME_hrfanb03	AV	97	IR	RO	Circuit B Fan #3 Hours
RUNTIME_hrfanb04	AV	98	IR	RO	Circuit B Fan #4 Hours
RUNTIME_hrfanb05	AV	99	IR	RO	Circuit B Fan #5 Hours
RUNTIME_hrfanb06	AV	100	IR	RO	Circuit B Fan #6 Hours
RUNTIME_hrfanb07	AV	101	IR	RO	Circuit B Fan #7 Hours
RUNTIME_hrfanb08	AV	102	IR	RO	Circuit B Fan #8 Hours
RUNTIME_hrfanb09	AV	103	IR	RO	Circuit B Fan #9 Hours
RUNTIME_hrfanb10	AV	104	IR	RO	Circuit B Fan #10 Hours
RUNTIME_hrfanb11	AV	105	IR	RO	Circuit B Fan #11 Hours
RUNTIME_hrfanb12	AV	106	IR	RO	Circuit B Fan #12 Hours
RUNTIME_hrfanb13	AV	107	IR	RO	Circuit B Fan #13 Hours
RUNTIME_hrfanb14	AV	108	IR	RO	Circuit B Fan #14 Hours
RUNTIME_st_cp_a	AV	74	IR	RO	Compressor A Starts
RUNTIME_st_cp_b	AV	76	IR	RO	Compressor B Starts
RUNTIME_st_mach	AV	72	IR	RO	Machine Starts
RUNTIME_VlctA	AV	79	IR	RO	VI Cycle Count A
RUNTIME_VlctB	AV	80	IR	RO	VI Cycle Count B
SERVICE1_AntiFrz	BV	113		RO	Pump Rot. AntiFrz Protec
SERVICE1_apr_en	AV	355		RO	Approach Ctrl at Start??

LEGEND

AV — Analog Value	IR — Intrinsic Reporting
BV — Binary Value	RO — Read Only
CMD — Command	RW — Read Write
COV — Change of Value	TL — Trend Log

APPENDIX E — BACNET IP POINTS (cont)

OBJECT NAME	OBJECT TYPE	INSTANCE	OPTION	PV ACCESS	DESCRIPTION
SERVICE1_auto_sm	BV	111		RO	Auto Start When SM Lost
SERVICE1_cdrv_cfg	BV	110		RO	Send comp. drive config?
SERVICE1_ewt_cirA	AV	342		RO	EWT Probe on Cir A Side
SERVICE1_ewt_opt	BV	105		RO	Entering Fluid Control
SERVICE1_fastcapr	AV	341		RO	Fast Capacity Recovery
SERVICE1_fdrv_cfg	BV	109		RO	Send fan drive config?
SERVICE1_flui_tpy	AV	338		RO	Evaporator Fluid Type, 1 = Water, 2 = Med Brine, 3 = Low Brine
SERVICE1_freez_ov	AV	346		RO	Freeze Override Offset
SERVICE1_freezesp	AV	339		RO	Brine Freeze Setpoint
SERVICE1_heatersp	AV	345		RO	Evap Heater Delta Spt
SERVICE1_leak_thr	AV	343			Leakage Charge Threshold
SERVICE1_leak_tmr	AV	344		RO	Leakage Charge Timer
SERVICE1_metric	BV	108		RO	Metric Units? (Blackbox)
SERVICE1_mini_lwt	AV	340		RO	Brine Minimum Fluid Temp
SERVICE1_odrecspd	AV	350		RO	Oil Delta Recover Speed
SERVICE1_odtrspd	AV	348		RO	Oil Delta Trigger Speed
SERVICE1_orectim	AV	351		RO	Oil Recover Time
SERVICE1_otrigtim	AV	349		RO	Oil Trigger Time
SERVICE1_RFI_conf	BV	107		RO	Compressor RFI Filter En
SERVICE1_ser_pass	BV	106		RO	Service Password
SERVICE1_ViChkEn	BV	112		RW	VI Self-Test Enable
SERVICE1_ViPwrChk	AV	347		RW	VI Self-Test Threshold
SERVICE1_vistrtdt	AV	353		RO	High VI Time at Start
SERVICE1_vistrten	AV	354		RO	Enable High VI at Start
SERVICE1_wateesys	AV	352		RO	Water Temp Hysteresis
SETPOINT_cramp_sp	AV	553		RW	Cooling Ramp Loading
SETPOINT_csp1	AV	550		RW	Cooling Setpoint 1
SETPOINT_csp2	AV	551		RW	Cooling Setpoint 2
SETPOINT_ice_sp	AV	552		RW	Cooling Ice Setpoint
SETPOINT_lim_sp1	AV	554		RW	Switch Limit Setpoint 1
SETPOINT_lim_sp2	AV	555		RW	Switch Limit Setpoint 2
SETPOINT_lim_sp3	AV	556		RW	Switch Limit Setpoint 3
TEMP_CHWSTEMP	AV	49	COV IR	RO	Chill Water Temp (Opt.)
TEMP_COOL_EWT	AV	29	COV IR	RO	Evap Entering Fluid
TEMP_COOL_LWT	AV	30	COV IR	RO	Evap Leaving Fluid
TEMP_CP_TMP_A	AV	37	COV IR	RO	Motor Temperature Cir A
TEMP_CP_TMP_B	AV	45	COV IR	RO	Motor Temperature Cir B
TEMP_DGT_A	AV	36	COV IR	RO	Discharge Gas Temp Cir A
TEMP_DGT_B	AV	44	COV IR	RO	Discharge Gas Temp Cir B
TEMP_ECO_T_A	AV	38	COV IR	RO	EXV Eco. Tmp Cir A
TEMP_ECO_T_B	AV	46	COV IR	RO	EXV Eco. Tmp Cir B
TEMP_LIQ_T_A	AV	39	COV IR	RO	Liquid Temperature A
TEMP_LIQ_T_B	AV	47	COV IR	RO	Liquid Temperature B
TEMP_OAT	AV	31	COV IR	RO	Outdoor Air Temperature
TEMP_SCT_A	AV	32	COV IR	RO	Saturated Cond Tmp Cir A

LEGEND

AV — Analog Value	IR — Intrinsic Reporting
BV — Binary Value	RO — Read Only
CMD — Command	RW — Read Write
COV — Change of Value	TL — Trend Log

APPENDIX E — BACNET IP POINTS (cont)

OBJECT NAME	OBJECT TYPE	INSTANCE	OPTION	PV ACCESS	DESCRIPTION
TEMP_SCT_B	AV	40	COV IR	RO	Saturated Cond Tmp Cir B
TEMP_SLT_A	AV	34	COV IR	RO	Saturated Liquid Temp A
TEMP_SLT_B	AV	42	COV IR	RO	Saturated Liquid Temp B
TEMP_SPACETMP	AV	48	COV IR	RO	Space Temp (Opt.)
TEMP_SST_A	AV	33	COV IR	RO	Saturated Suction Temp A
TEMP_SST_B	AV	41	COV IR	RO	Saturated Suction Temp B
TEMP_SUCT_A	AV	35	COV IR	RO	Compressor Suction Tmp A
TEMP_SUCT_B	AV	43	COV IR	RO	Compressor Suction Tmp B
TL_cap_pc_a	TL	40	IR	RW	Estimated Capacity A
TL_cap_pc_b	TL	42	IR	RW	Estimated Capacity B
TL_COOL_EWT	TL	4	IR	RW	Evap Entering Fluid
TL_COOL_LWT	TL	5	IR	RW	Evap Leaving Fluid
TL_CP_TMP_A	TL	10	IR	RW	Motor Temperature Cir A
TL_CP_TMP_B	TL	15	IR	RW	Motor Temperature Cir B
TL_ctrl_wt	TL	38	IR	RW	Controlled Water Temp
TL_DEM_LIM	TL	3	IR	RW	Active Demand Limit Val
TL_DGT_A	TL	9	IR	RW	Discharge Gas Temp Cir A
TL_DGT_B	TL	14	IR	RW	Discharge Gas Temp Cir B
TL_drv_Fa	TL	29	IR	RW	Cir A Drive Frequency
TL_drv_Fb	TL	32	IR	RW	Cir B Drive Frequency
TL_drv_la	TL	28	IR	RW	Cir A Drive Amps
TL_drv_lb	TL	31	IR	RW	Cir B Drive Amps
TL_drv_pwr	TL	33	IR	RW	Total Comp Drive Power
TL_drv_pwra	TL	27	IR	RW	Cir A Drive Power
TL_drv_pwrb	TL	30	IR	RW	Cir B Drive Power
TL_eco_a	TL	43	IR	RW	EXV Eco Position Cir A
TL_eco_b	TL	44	IR	RW	EXV Eco Position Cir B
TL_ECO_P_A	TL	17	IR	RW	Economizer Pressure A
TL_ECO_P_B	TL	18	IR	RW	Economizer Pressure B
TL_ECO_T_A	TL	11	IR	RW	EXV Eco. Tmp Cir A
TL_ECO_T_B	TL	16	IR	RW	EXV Eco. Tmp Cir B
TL_EXV_A	TL	35	IR	RW	EXV Position Circuit A
TL_EXV_B	TL	37	IR	RW	EXV Position Circuit B
TL_fan_f_a	TL	45	IR	RW	Fan Freq Cir A
TL_fan_f_b	TL	46	IR	RW	Fan Freq Cir B
TL_fd_pwr	TL	51	IR	RW	Total Fan Drive Power
TL_fd_pwr	TL	51	IR	RW	Total Fan Drive Power
TL_fd_pwra1	TL	47	IR	RW	Fan Drive Power A1
TL_fd_pwra1	TL	47	IR	RW	Fan Drive Power A1
TL_fd_pwra2	TL	48	IR	RW	Fan Drive Power A2
TL_fd_pwra2	TL	48	IR	RW	Fan Drive Power A2
TL_fd_pwrb1	TL	49	IR	RW	Fan Drive Power B1
TL_fd_pwrb1	TL	49	IR	RW	Fan Drive Power B1
TL_fd_pwrb2	TL	50	IR	RW	Fan Drive Power B2
TL_fd_pwrb2	TL	50	IR	RW	Fan Drive Power B2
TL_HR_CP_A	TL	23	IR	RW	Compressor A Hours
TL_HR_CP_B	TL	25	IR	RW	Compressor B Hours
TL_HR_MACH	TL	21	IR	RW	Machine Operating Hours

LEGEND

AV — Analog Value	IR — Intrinsic Reporting
BV — Binary Value	RO — Read Only
CMD — Command	RW — Read Write
COV — Change of Value	TL — Trend Log

APPENDIX E — BACNET IP POINTS (cont)

OBJECT NAME	OBJECT TYPE	INSTANCE	OPTION	PV ACCESS	DESCRIPTION
TL_OAT	TL	6	IR	RW	Outdoor Air Temperature
TL_OIL_L_A	TL	19	IR	RW	Oil Level Input A
TL_OIL_L_B	TL	20	IR	RW	Oil Level Input B
TL_ov_exv_a	TL	34	IR	RW	EXV Override Circuit A
TL_ov_exv_b	TL	36	IR	RW	EXV Override Circuit B
TL_overrida	TL	39	IR	RW	Override Capacity Nb A
TL_overridb	TL	41	IR	RW	Override Capacity Nb B
TL_SCT_A	TL	7	IR	RW	Saturated Cond Tmp Cir A
TL_SCT_B	TL	12	IR	RW	Saturated Cond Tmp Cir B
TL_SP_SEL	TL	2	IR	RW	Setpoint Select
TL_SST_A	TL	8	IR	RW	Saturated Suction Temp A
TL_SST_B	TL	13	IR	RW	Saturated Suction Temp B
TL_st_cp_a	TL	24	IR	RW	Compressor A Starts
TL_st_cp_b	TL	26	IR	RW	Compressor B Starts
TL_st_mach	TL	22	IR	RW	Machine Starts
TL_STATUS	TL	1	IR	RW	Run Status
UPDTHOUR_hr_cp_a	AV	358		RO	Compressor A Hours
UPDTHOUR_hr_cp_b	AV	360		RO	Compressor B Hours
UPDTHOUR_hr_cpum1	AV	362		RO	Evap Pump #1 Hours
UPDTHOUR_hr_cpum2	AV	363		RO	Evap Pump #2 Hours
UPDTHOUR_hr_mach	AV	356		RO	Machine Operating Hours
UPDTHOUR_hrfana01	AV	366		RO	Circuit A Fan #1 Hours
UPDTHOUR_hrfana02	AV	367		RO	Circuit A Fan #2 Hours
UPDTHOUR_hrfana03	AV	368		RO	Circuit A Fan #3 Hours
UPDTHOUR_hrfana04	AV	369		RO	Circuit A Fan #4 Hours
UPDTHOUR_hrfana05	AV	370		RO	Circuit A Fan #5 Hours
UPDTHOUR_hrfana06	AV	371		RO	Circuit A Fan #6 Hours
UPDTHOUR_hrfana07	AV	372		RO	Circuit A Fan #7 Hours
UPDTHOUR_hrfana08	AV	373		RO	Circuit A Fan #8 Hours
UPDTHOUR_hrfana09	AV	374		RO	Circuit A Fan #9 Hours
UPDTHOUR_hrfana10	AV	375		RO	Circuit A Fan #10 Hours
UPDTHOUR_hrfana11	AV	376		RO	Circuit A Fan #11 Hours
UPDTHOUR_hrfana12	AV	377		RO	Circuit A Fan #12 Hours
UPDTHOUR_hrfana13	AV	378		RO	Circuit A Fan #13 Hours
UPDTHOUR_hrfana14	AV	379		RO	Circuit A Fan #14 Hours
UPDTHOUR_hrfanb01	AV	380		RO	Circuit B Fan #1 Hours
UPDTHOUR_hrfanb02	AV	381		RO	Circuit B Fan #2 Hours
UPDTHOUR_hrfanb03	AV	382		RO	Circuit B Fan #3 Hours
UPDTHOUR_hrfanb04	AV	383		RO	Circuit B Fan #4 Hours
UPDTHOUR_hrfanb05	AV	384		RO	Circuit B Fan #5 Hours
UPDTHOUR_hrfanb06	AV	385		RO	Circuit B Fan #6 Hours
UPDTHOUR_hrfanb07	AV	386		RO	Circuit B Fan #7 Hours
UPDTHOUR_hrfanb08	AV	387		RO	Circuit B Fan #8 Hours
UPDTHOUR_hrfanb09	AV	388		RO	Circuit B Fan #9 Hours
UPDTHOUR_hrfanb10	AV	389		RO	Circuit B Fan #10 Hours
UPDTHOUR_hrfanb11	AV	390		RO	Circuit B Fan #11 Hours
UPDTHOUR_hrfanb12	AV	391		RO	Circuit B Fan #12 Hours
UPDTHOUR_hrfanb13	AV	392		RO	Circuit B Fan #13 Hours

LEGEND

AV — Analog Value	IR — Intrinsic Reporting
BV — Binary Value	RO — Read Only
CMD — Command	RW — Read Write
COV — Change of Value	TL — Trend Log

APPENDIX E — BACNET IP POINTS (cont)

OBJECT NAME	OBJECT TYPE	INSTANCE	OPTION	PV ACCESS	DESCRIPTION
UPDTHOUR_hrfanb14	AV	393		RO	Circuit B Fan #14 Hours
UPDTHOUR_st_cp_a	AV	359		RO	Compressor A Starts
UPDTHOUR_st_cp_b	AV	361		RO	Compressor B Starts
UPDTHOUR_st_mach	AV	357		RO	Machine Starts Number
UPDTHOUR_VlctA	AV	364		RO	VI Cycle Count A
UPDTHOUR_VlctB	AV	365		RO	VI Cycle Count B
USERCONF_use_pass	AV	9		RW	User Password
VLT_DRV_drv_CCTa	AV	123	IR	RO	Cir A Drive Ctrl Card T
VLT_DRV_drv_CCTb	AV	133	IR	RO	Cir B Drive Ctrl Card T
VLT_DRV_drv_DCVa	AV	121	IR	RO	Cir A Drive DC Link Volt
VLT_DRV_drv_DCVb	AV	131	IR	RO	Cir B Drive DC Link Volt
VLT_DRV_drv_Fa	AV	119	IR	RO	Cir A Drive Frequency
VLT_DRV_drv_Fb	AV	129	IR	RO	Cir B Drive Frequency
VLT_DRV_drv_HSTa	AV	122	IR	RO	Cir A Drive Heat Sink T
VLT_DRV_drv_HSTb	AV	132	IR	RO	Cir B Drive Heat Sink T
VLT_DRV_drv_HTRa	AV	124	IR	RO	Cir A Drive Heater
VLT_DRV_drv_HTRb	AV	134	IR	RO	Cir B Drive Heater
VLT_DRV_drv_Ia	AV	116	IR	RO	Cir A Drive Amps
VLT_DRV_drv_Ib	AV	126	IR	RO	Cir B Drive Amps
VLT_DRV_drv_pwr	AV	135	IR	RO	Total Comp Drive Power
VLT_DRV_drv_pwra	AV	115	IR	RO	Cir A Drive Power
VLT_DRV_drv_pwrb	AV	125	IR	RO	Cir B Drive Power
VLT_DRV_drv_Sa	AV	118	IR	RO	Cir A Drive Speed
VLT_DRV_drv_Sb	AV	128	IR	RO	Cir B Drive Speed
VLT_DRV_drv-Ta	AV	120	IR	RO	Cir A Drive Torque
VLT_DRV_drv-Tb	AV	130	IR	RO	Cir B Drive Torque
VLT_DRV_drv_Va	AV	117	IR	RO	Cir A Drive Voltage
VLT_DRV_drv_Vb	AV	127	IR	RO	Cir B Drive Voltage
VLT_DRV_SET_DRVA	BV	73	IR	RO	Drive A Attach
VLT_DRV_SET_DRVB	BV	74	IR	RO	Drive B Attach
VLT_DRV_VLT_COMA	BV	75	IR	RO	Comm with Drive A Ok
VLT_DRV_VLT_COMB	BV	76	IR	RO	Comm with Drive B Ok

LEGEND

AV — Analog Value	IR — Intrinsic Reporting
BV — Binary Value	RO — Read Only
CMD — Command	RW — Read Write
COV — Change of Value	TL — Trend Log

START-UP CHECKLIST FOR 30XV LIQUID CHILLERS

(Remove and use for Job File)

NOTE: To avoid injury to personnel and damage to equipment or property when completing the procedures listed in this start-up checklist, use good judgment, follow safe practices, and adhere to the safety considerations/information as outlined in preceding sections of this Controls, Start-Up, Operation, Service and Troubleshooting document.

A. PROJECT INFORMATION

Job name _____
 Address _____
 City _____ State _____ Zip _____

Equipment tag/mark for _____
 Installing contractor _____
 Sales office _____
 Start-up performed by _____

Design Information

	CAPACITY	EWT	LWT	FLUID TYPE	FLOW RATE	P.D.	AMBIENT
Evaporator							

Unit

Model _____ Serial _____

Compressors

Compressor A
 Model _____ Serial _____

Compressor B
 Model _____ Serial _____

Evaporator

Model _____ Serial _____

B. PRELIMINARY EQUIPMENT CHECK (This section to be completed by installing contractor)

1. Is there any physical damage? Yes No
 Will this prevent start-up? Yes No
 Description: _____

2. Unit is installed level as per the installation instructions. Yes No
3. Power supply agrees with the unit nameplate. Yes No
4. Correct control voltage _____ vac. Yes No
5. Electrical power wiring is installed properly. Yes No
6. Unit is properly grounded. Yes No
7. Electrical circuit protection has been sized and installed properly. Yes No
8. All terminals are tight. Yes No
9. All plug assemblies are tight. Yes No
10. All cables, thermistors and transducers have been inspected for cross wires. Yes No
11. All thermistors are fully inserted into wells. Yes No
12. Oil separator heaters energized for 24 hours before start-up. Yes No
13. Relief valve vent piping per local codes. Yes No

Chilled Water System Check

- 1. All chilled water valves are open. Yes No
- 2. All piping is connected properly. Yes No
- 3. All air has been purged from the system. Yes No
- 4. Chilled water pump starter controlled by chiller. Yes No
- 5. Chilled water flow switch operational. Yes No
- 6. Units installed in open loop: inlet piping to evaporator includes a 20 mesh strainer within 10 ft of unit. Yes No
- 7. Water loop volume greater than 3 gal/ton (40 L/kW) for air conditioning or 6 gal/ton (80 L/kW) for process cooling and low ambient operation. Yes No
- 8. Proper loop freeze protection provided to ____ °F (°C).
Antifreeze type _____ Concentration ____%.
(If antifreeze solution is not utilized on 30XV machines and the minimum outdoor ambient is below 32°F (0° C), then items 10 and 11 have to be completed to provide evaporator freeze protection to -20°F (-28.9°C). Refer to Installation Instructions for proper evaporator winterization procedure.) Yes No
- 9. Outdoor piping wrapped with electric heater tape. Yes No
- 10. Evaporator heaters and oil separator heaters installed and operational. Yes No
- 11. Is the Unit equipped with low ambient head pressure control?
a. If yes, are wind baffles installed? Yes No

C. UNIT START-UP

- 1. All liquid line service valves are open. Yes No
- 2. Verify actuated ball valve (ABV) operation. Yes No
- 3. All suction and discharge service valves are open. Yes No
- 4. Economizer service valves open. (Leaving Main EXV and Leaving Brazed Plate Heat Exchanger [Economizer]) Yes No
- 5. Oil service valves open. Yes No
- 6. Leak check unit. Locate, repair and report any refrigerant leaks. Yes No
- 7. Voltage at terminal block is within unit nameplate range. Yes No
 Check voltage imbalance: A-B _____ A-C _____ B-C _____
 Average voltage = _____ (A-B + A-C + B-C)/3
 Maximum deviation from average voltage = _____
 Voltage imbalance = _____ % (max. deviation / average voltage) X 100
 Is voltage imbalance less than 2%. Yes No
 (DO NOT start chiller if voltage imbalance is greater than 2%. Contact local utility for assistance.)
- 8. Verify evaporator flow rate
 Pressure entering evaporator _____ psig (kPa)
 Pressure leaving evaporator _____ psig (kPa)
 Evaporator pressure drop _____ psig (kPa)
 Psig x 2.31 ft/psi = _____ ft of water
 kPa x 0.334 m/psi = _____ mm of water
 Evaporator flow rate _____ gpm (L/s) (See Evaporator Pressure Drop Curve)

Start and Operate Machine

- 1. Complete component test utilizing Quick Test Mode
- 2. Operate all condenser fans and verify operation and rotation.
- 3. Operate compressors using manual test mode.
- 4. Check refrigerant and oil charge. Record charge information.
- 5. Record compressor and condenser fan motor current.
- 6. Record operating data.
- 7. Provide operating instructions to owner’s personnel.

CUT ALONG DOTTED LINE

Refrigerant Charge

Additional charge required Circuit A _____ Circuit B _____

Oil Charge

Additional charge required Circuit A _____ Circuit B _____

Oil Separator Oil Level Unit Sizes 140-325 and 350 Circuit B

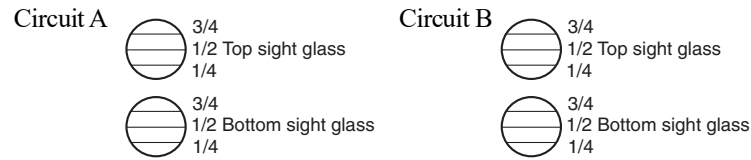

NOTE: Oil level should be visible in top sight glass.

SmartView™ Software Version

ACG-SR-10D2AA ___ ___ ___

To obtain software version, navigate to **Menu → General Parameters** and find "SW Version" displayed in this table.

Record Configuration Information

PATH	SmartView™ DESCRIPTION	DEFAULT	ENTRY
Login Button	Language	English	
	Units	US Imp	
Main Menu→General Parameters	Setpoint Select	0 (Auto)	
Main Menu→Configuration Menu→ General Configuration	Cir Priority Sequence	0 (Auto)	
	Ramp Loading Enable	0 (No)	
	Unit Off to On Delay	1 min	
	Demand Limit Type Select	0 (None)	
	Night Mode Start Hour	0	
	Night Mode End Hour	0	
	Night Capacity Limit	100%	
	Ice Mode Enable	0 (No)	
Main Menu→Configuration Menu→ Pump Configuration	Evap Pumps Sequence	0 (No Pump)	
	Pump Auto Rotation Delay	48 hours	
	Pump Sticking Protection	0 (No)	
	Flow Checked If Pump Off	1 (Yes)	
Main Menu→Configuration Menu→User Config.	User Password	11	
Main Menu→Configuration Menu→ Reset Configuration	Cooling Reset Select	0 (No reset)	
	OAT No Reset Value	14° F (-10° C)	
	OAT Full Reset Value	14° F (-10° C)	
	Delta T No Reset Value	0 °F (0 °C)	
	Delta T Full Reset Value	0 °F (0 °C)	
	Current No Reset Value	0 mA	
	Current Full Reset Value	0 mA	
	Space T No Reset Value	14° F (-10° C)	
	Space T Full Reset Value	14° F (-10° C)	
	Cooling Reset Deg. Value	0° F (0° C)	
Main Menu→Configuration Menu→ Factory Parameters	Unit Capacity	Unit Dependent	
	Power Supply Voltage	Unit Dependent	
	Energy Management Module	0	
	Leakage Charge Detection	0	

CUT ALONG DOTTED LINE

CUT ALONG DOTTED LINE

Record Configuration Information

PATH	SmartView™ DESCRIPTION	DEFAULT	ENTRY	
Main Menu→Configuration Menu→ Service Parameters	Evaporator Fluid Type	1 (Water)		
	Entering Fluid Control	no		
	Brine Freeze Setpoint	34° F (1.1° C)		
	Brine Minimum fluid temp	38° F (3.3° C)		
	Fast Capacity Recovery	0		
	EWT Probe on cir A side	yes		
	Service Password	88		
	Leakage Charge Threshold	2.5 Volts		
	Leakage Charge Timer	60 min.		
	Compressor RFI Filter En	on		
	Metric Units?	no		
	Send fan drive config?	yes		
	Send comp. Drive config?	yes		
	Evaporator Heater Delta Spt	2 (Number of deg added to brine freeze setpoint to enable heater)		
	Freeze override offset	0 °F (0 °C)		
	Auto Start When SM Lost	0 (disable)		
	VI Self-Test Threshold	1.15 kW		
	Pump Rot. AntiFrz Protec	on		
	Main Menu→Configuration Menu→ Master Slave Config	Master/Slave Select	0 (disable)	
		Master Control Type	1 (Local)	
Slave Address		2		
Lead Lag Select		0 (Always Lead)		
Lead/Lag Balance Delta		168 hours		
Lead/Lag Start Timer		10 min		
Lead Pulldown Time		0 min		
Start If Error Higher		4 °F (2.2 °C)		
Lag Minimum Running Time		0 min		
Lag Unit Pump Control		0 (Stop if Unit Stops)		
Chiller In Series		0 (No)		
Main Menu→Setpoint Table	Cooling Setpoint 1	44° F (6.7° C)		
	Cooling Setpoint 2	44° F (6.7° C)		
	Cooling Ice Setpoint	44° F (6.7° C)		
	Cooling Ramp Loading	1°F (0.6 °C)		
	Switch Limit Setpoint 1	100%		
	Switch Limit Setpoint 2	100%		
	Switch Limit Setpoint 3	100%		

LEGEND

Spt — Set Point

Component Test — Complete the following tests to make sure all peripheral components are operational before the compressors are started.

PATH	SmartView™ DESCRIPTION	CHECK WHEN COMPLETE
	Quick Test Enable (Unit must be in Local OFF)	
	Circuit A EXV Position	
	Circuit A Oil Solenoid	
	EXV Eco Position Cir A	
	Oil Heater Circuit A	
	Capacity Cir A Output	
	Comp A Running Output	
	Isolation Valve State A	
	Circuit A VI	
	VariFan Speed A	
	Circuit B EXV Position	
	Circuit B Oil Solenoid	
	EXV Eco Position Cir B	
	Oil Heater Circuit B	
	Capacity Cir B Output	
	Comp B Running Output	
	Isolation Valve State B	
	Circuit B VI	
	VariFan Speed B	
	Evaporator Heater	
	Evaporator Pump 1	
	Evaporator Pump 2	
	Alarm Relay Status	
	Shutdown Relay Status	
	Running Relay Status	
	Alert Relay Switch	
	Set Flow Switch	
	Capacity Total Output	
	Comp drive heater A	
	Comp drive heater B	
	Fan Contactor 1A	
	Fan Contactor 2A	
	Fan Contactor 3A	
	Fan Contactor 4A	
	Fan Contactor 5A	
	Fan Contactor 6A	
	Fan Contactor 7A	
	Fan Contactor 8A	
	Fan Contactor 1B	
	Fan Contactor 2B	
	Fan Contactor 3B	
	Fan Contactor 4B	
	Fan Contactor 5B	
	Fan Contactor 6B	
	Fan Contactor 7B	
	Fan Contactor 8B	
	Comp. HW Enable A	
	Comp. HW Enable B	
	Control Box Heater	

Main Menu→Quick Test Table

CUT ALONG DOTTED LINE

CUT ALONG DOTTED LINE

Operating Data:

Record the following information from the Run Status, Temperatures and Outputs Modes when machine is in a stable operating condition.

TEMPERATURES

EVAPORATOR ENTERING FLUID _____
 EVAPORATOR LEAVING FLUID _____
 CONTROL POINT _____
 CAPACITY _____
 OUTSIDE AIR TEMPERATURE _____
 CHWS TEMPERATURE _____ (Dual Chiller Control Only)

CIRCUIT A

CIRCUIT B

SATURATED COND TMP CIRC A	_____	SATURATED COND TMP CIRC B	_____
SATURATED SUCTION TEMP A	_____	SATURATED SUCTION TEMP B	_____
SATURATED LIQUID TMP A	_____	SATURATED LIQUID TMP B	_____
COMPRESSOR SUCTION TMP A	_____	COMPRESSOR SUCTION TMP B	_____
DISCHARGE GAS TEMP CIR A	_____	DISCHARGE GAS TEMP CIR B	_____
MOTOR TEMPERATURE CIR A	_____	MOTOR TEMPERATURE CIR B	_____
EXV ECO. TMP CIR A	_____	EXV ECO. TMP CIR B	_____
LIQUID TEMPERATURE A	_____	LIQUID TEMPERATURE B	_____

COMPRESSOR MOTOR CURRENT

L1 L2 L3

COMPRESSOR A1 _____
 COMPRESSOR B1 _____

CONDENSER FAN MOTOR CURRENT, STANDARD TIER UNITS

L1 L2 L3 L1 L2 L3

FAN MOTOR A1	_____	_____	_____	FAN MOTOR B1	_____	_____	_____
FAN MOTOR A2	_____	_____	_____	FAN MOTOR B2	_____	_____	_____
FAN MOTOR A3	_____	_____	_____	FAN MOTOR B3	_____	_____	_____
FAN MOTOR A4	_____	_____	_____	FAN MOTOR B4	_____	_____	_____
FAN MOTOR A5	_____	_____	_____	FAN MOTOR B5	_____	_____	_____
FAN MOTOR A6	_____	_____	_____	FAN MOTOR B6	_____	_____	_____
FAN MOTOR A7	_____	_____	_____	FAN MOTOR B7	_____	_____	_____
FAN MOTOR A8	_____	_____	_____	FAN MOTOR B8	_____	_____	_____
FAN MOTOR A9	_____	_____	_____	FAN MOTOR B9	_____	_____	_____
FAN MOTOR A10	_____	_____	_____	FAN MOTOR B10	_____	_____	_____
FAN MOTOR A11	_____	_____	_____	FAN MOTOR B11	_____	_____	_____
FAN MOTOR A12	_____	_____	_____	FAN MOTOR B12	_____	_____	_____

CONDENSER FAN MOTOR CURRENT, STANDARD TIER WITH LOW AMBIENT MID AND HIGH TIER

Hz A

VFD A1 _____
 VFD A2 _____
 VFD B1 _____
 VFD B2 _____

HEATER CURRENT

EVAPORATOR HEATER CURRENT _____
 OIL SEPARATOR HEATER CURRENT CIRCUIT A _____
 OIL SEPARATOR HEATER CURRENT CIRCUIT B _____

COMMENTS:

CUT ALONG DOTTED LINE

CUT ALONG DOTTED LINE

SIGNATURES:

Start-up
Technician

_____ Date _____

Customer
Representative

_____ Date _____

© 2021 Carrier

Manufacturer reserves the right to discontinue, or change at any time, specifications or designs without notice and without incurring obligations.
Catalog No. 04-53300222-01 Printed in U.S.A. Form 30XV-4T Pg CL-8 12-21 Replaces: 30XV-3T