

FOR QUESTIONS, CALL THE
Highwoods Group
REGION 40
PHONE: (919) 875 - 0420
EMAIL: reg40@captivair.com

PATENT NUMBERS

AC-PSP (UNITED STATES) - US PATENT 7963830 B2.
AC-PSP WALL (CANADA) - CA PATENT 2820509.
AC-PSP ISLAND (CANADA) - CA PATENT 2520330.

HOOD INFORMATION - JOB#7032765

| HOOD NO | TAG | MODEL | MANUFACTURER | LENGTH | MAX COOKING TEMP | TYPE | APPLIANCE DUTY | DESIGN CFM/FT | TOTAL EXH CFM | EXHAUST PLENUM RISER(S) | | | | MUA CFM | AC CFM | HOOD CONSTRUCTION | HOOD CONFIG | | | |
|---------|-----|------------------|--------------|--------|------------------|------|----------------|---------------|---------------|-------------------------|------|--------|------|---------|---------|-------------------|-------------|----------------------|-------|------------|
| | | | | | | | | | | WIDTH | LENG | HEIGHT | DIA | | | | CFM | VEL | SP | END TO END |
| 1 | | 5424 ND-2-ACSP-F | CAPTIVEAIRE | 12' 9" | 600 DEG | I | HEAVY | 200 | 2550 | 10' | 24' | 4' | 2550 | 1530 | -0.966" | 1300 | 696 | 430 SS WHERE EXPOSED | ALONE | ALONE |

HOOD INFORMATION

| HOOD NO | TAG | FILTER(S) | | | | | LIGHT(S) | | | UTILITY CABINET(S) | | | | FIRE SYSTEM PIPING | HOOD HANGING WEIGHT | | |
|---------|-----|-----------------------|-----|--------|--------|------------------------|----------|----------------|------------|--------------------|-------------|------------------|---------|--------------------|---------------------|--------------------|-------------------|
| | | TYPE | QTY | HEIGHT | LENGTH | EFFICIENCY @ 7 MICRONS | QTY | TYPE | WIRE GUARD | LOCATION | SIZE | FIRE SYSTEM TYPE | SIZE | | | ELECTRICAL MODEL # | SWITCHES QUANTITY |
| 1 | | CAPTRATE SOLID FILTER | 9 | 16" | 16" | 85% SEE FILTER SPEC | 8 | L55 SERIES E26 | NO | RIGHT | 12"x54"x24" | TANK FS | 4.0/4.0 | SC-311110MA | 1 LIGHT 1 FAN | YES | 1213 LBS |

HOOD OPTIONS

| HOOD NO | TAG | OPTION |
|---------|-----|---|
| 1 | | FIELD WRAPPER 10.00" HIGH FRONT, LEFT, RIGHT. INSULATION FOR BACK OF HOOD. RISER SENSOR INSTALL 6IN PLEN. RIGHT VERTICAL END PANEL 27" TOP WIDTH, 21" BOTTOM WIDTH, 80" HIGH INSULATED 430 SS. LEFT VERTICAL END PANEL 27" TOP WIDTH, 21" BOTTOM WIDTH, 80" HIGH INSULATED 430 SS. FULL DIMENSION HANGING BRACKET - FRONT. |

PERFORATED SUPPLY PLENUM(S)

| HOOD NO | TAG | POS | LENGTH | WIDTH | HEIGHT | TYPE | RISER(S) | | | | |
|---------|-----|-------|--------|-------|--------|------|----------|------|-----|--------|--------|
| | | | | | | | WIDTH | LENG | DIA | CFM | SP |
| 1 | | Front | 165' | 19' | 6' | MUA | 6" | 28" | | 432 | 0.127" |
| | | | | | | MUA | 6" | 28" | | 432 | 0.127" |
| | | | | | | MUA | 6" | 28" | | 432 | 0.127" |
| | | | | | | AC | | 8" | 116 | 0.043" | |
| | | | | | | AC | | 8" | 116 | 0.043" | |
| | | | | | | AC | | 8" | 116 | 0.043" | |
| | | | | | | AC | | 8" | 116 | 0.043" | |
| | | | | | | AC | | 8" | 116 | 0.043" | |

1" LAYER OF INSULATION FACTORY INSTALLED IN INTERNAL BACK STANDOFF. MEETS 0 INCH REQUIREMENTS FOR CLEARANCE TO COMBUSTIBLE SURFACES.

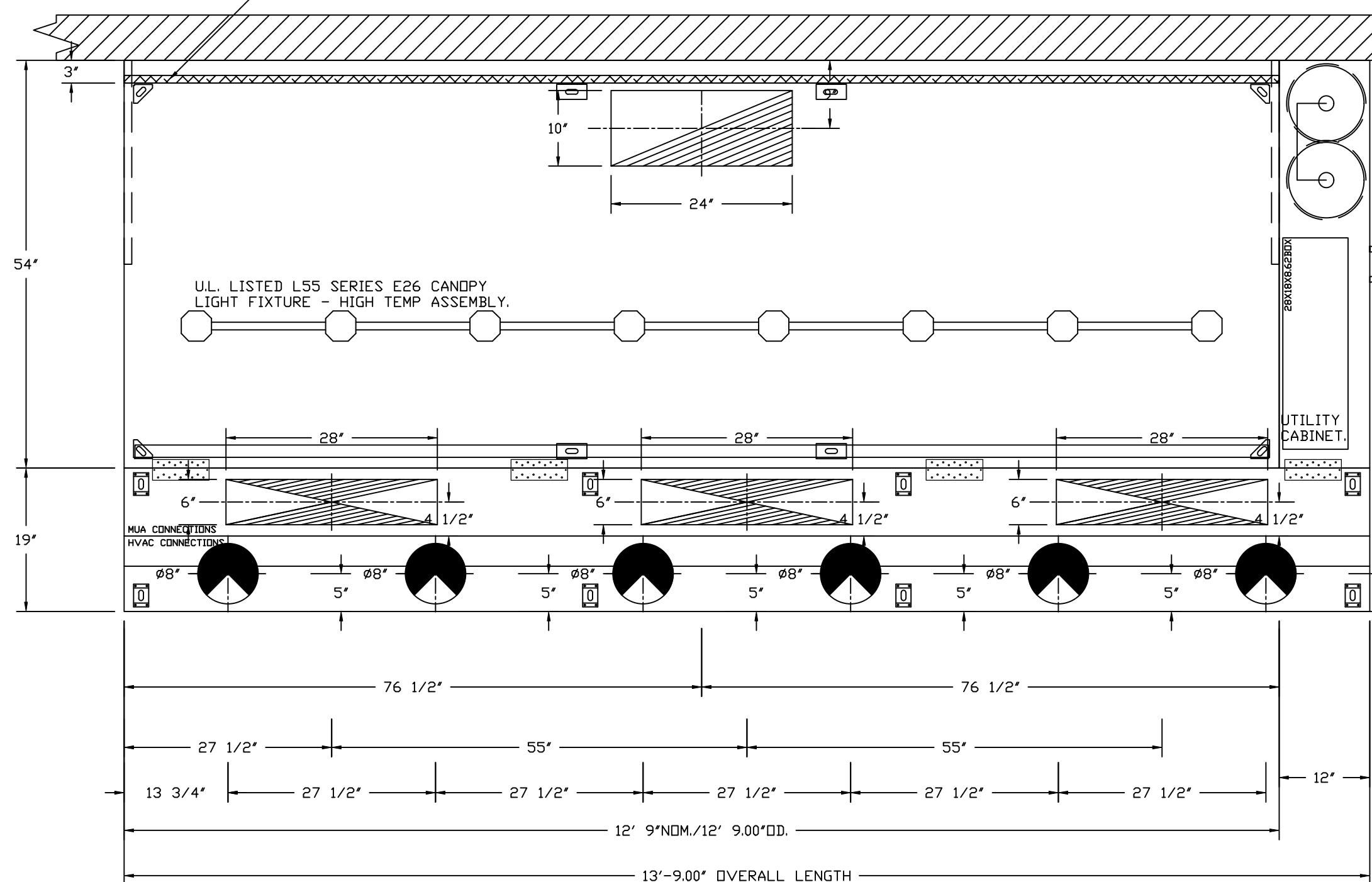

PLAN VIEW - HOOD #1
12' 9.00" LONG 5424ND-2-ACSP-F
NOTE: ADDITIONAL HANGING ANGLES PROVIDED FOR HOODS 12" AND LONGER.

ACSP SHIPS LOOSE FOR FIELD INSTALLATION

CLEARANCE TO COMBUSTIBLES

| HOODS # | SURFACE | *CLEARANCE |
|---------|---------|------------|
| 1 | TOP | 18" |
| | FRONT | 0" |
| | BACK | 0" |
| | LEFT | 18" |
| | RIGHT | 0" |

- *0" CLEARANCE TO COMBUSTIBLES CONFORMS TO UL710 STANDARD.
- HOOD MOUNTED UTILITY CABINETS REQUIRE 36" SERVICE CLEARANCE.

HOOD CORNER HANGING ANGLE (HARDWARE BY INSTALLER)

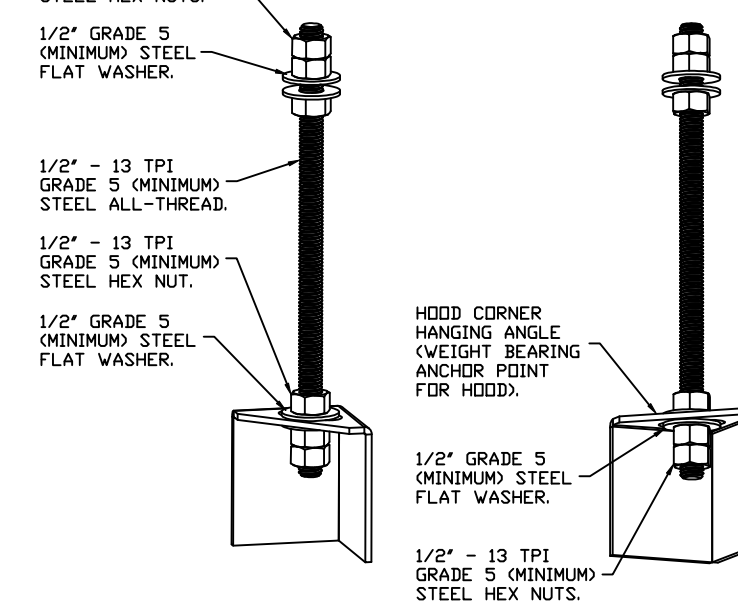

ASSEMBLY INSTRUCTIONS

HANGING ANGLE MUST BE SUPPORTED WITH 1/2" - 13 TPI GRADE 5 (MINIMUM) ALL-THREAD. SANDWICH HANGING ANGLES AND CEILING ANCHOR POINTS WITH 1/2" GRADE 5 (MINIMUM) STEEL FLAT WASHERS AND 1/2" - 13 TPI GRADE 5 (MINIMUM) HEX NUTS AS SHOWN. MUST USE DOUBLED HEX NUT CONFIGURATION BENEATH HOOD HANGING ANGLES AND ABOVE CEILING ANCHORS. MAINTAIN 1/4" OF EXPOSED THREADS BENEATH BOTTOM HEX NUT. TORQUE ALL HEX NUTS TO 57 FT-LBS.

SPECIFICATION: CAPTRATE® GREASE-STOP® SOLID FILTER

THE CAPTRATE GREASE-STOP SOLID FILTER IS A SINGLE-STAGE FILTER FEATURING A UNIQUE S-BAFFLE DESIGN IN CONJUNCTION WITH A SLOTTED REAR BAFFLE DESIGN, TO DELIVER EXCEPTIONAL FILTRATION EFFICIENCY.

FILTER IS STAINLESS STEEL CONSTRUCTION, AND SIZED TO FIT INTO STANDARD 2-INCH DEEP HOOD CHANNEL(S).

UNITS SHALL INCLUDE STAINLESS STEEL HANDLES AND A FASTENING DEVICE TO SECURE THE TWO COMPONENTS WHEN ASSEMBLED.

GREASE EXTRACTION EFFICIENCY PERFORMANCE SHALL REMOVE AT LEAST 75% OF GREASE PARTICLES FIVE MICRONS IN SIZE, AND 85% GREASE PARTICLES SEVEN MICRONS IN SIZE AND LARGER, WITH A CORRESPONDING PRESSURE DROP NOT TO EXCEED 1.0 INCHES OF WATER GAUGE.

THE CAPTRATE GREASE-STOP SOLID WAS TESTED TO ASTM STANDARD ASTM F2519-05. MANUFACTURER APPROVED FOR USE IN SOLID FUEL APPLICATIONS AS A SPARK ARRESTER.

EFFICIENCY VS. PARTICLE DIAMETER

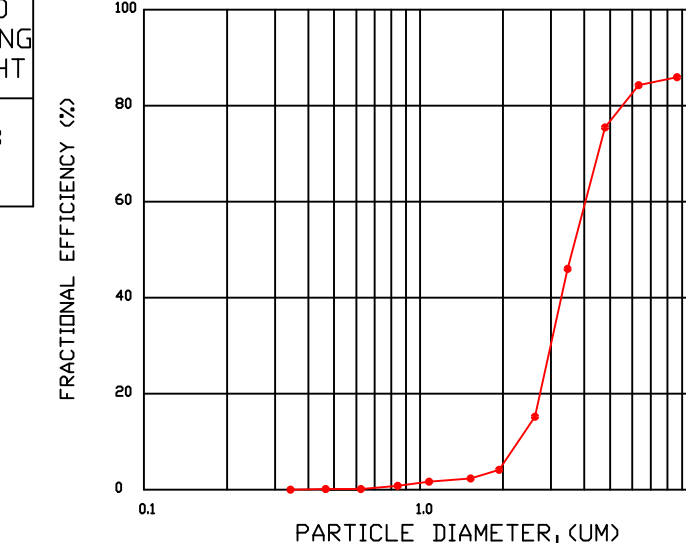

PRESSURE DROP VS. FLOW RATE

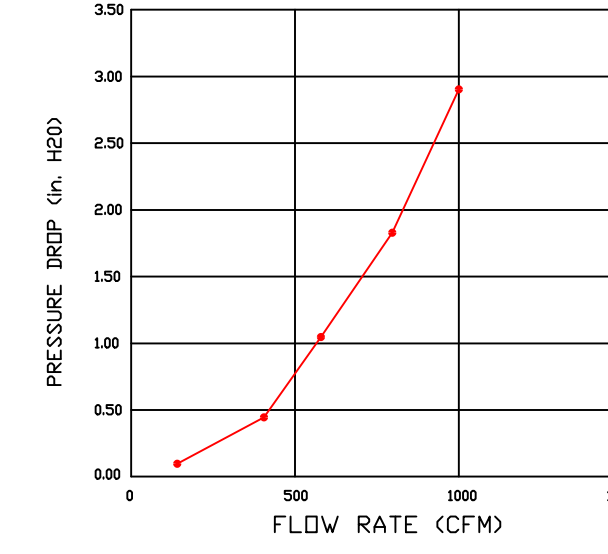

CAPTRATE FILTERS ARE BUILT IN COMPLIANCE WITH:

- NFPA #96.
- NSF STANDARD #2.
- UL STANDARD #1046.
- INT. MECH. CODE (IMC).
- ULC-S649.



FULL LENGTH HANGING ANGLE (HARDWARE BY INSTALLER)

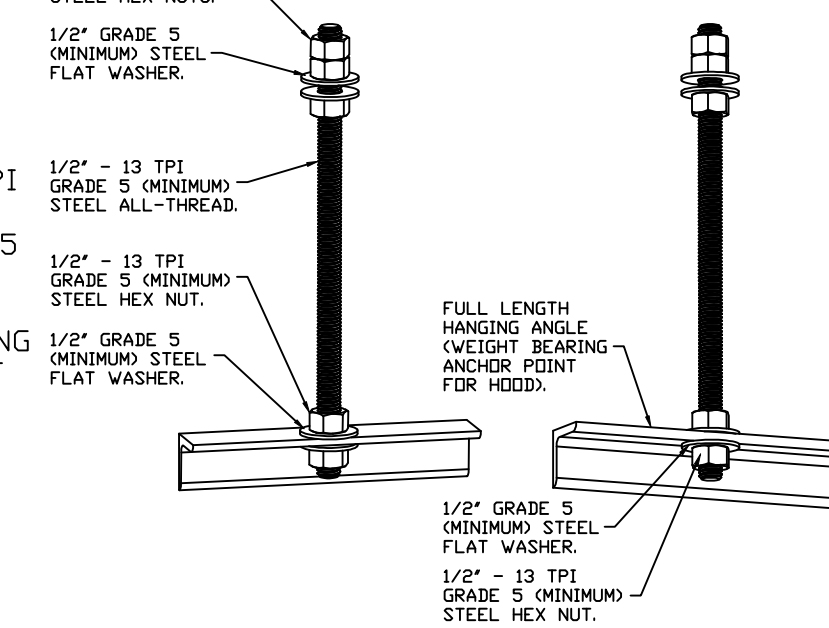

ASSEMBLY INSTRUCTIONS

HANGING ANGLE MUST BE SUPPORTED WITH 1/2" - 13 TPI GRADE 5 (MINIMUM) ALL-THREAD. SANDWICH HANGING ANGLES AND CEILING ANCHOR POINTS WITH 1/2" GRADE 5 (MINIMUM) STEEL FLAT WASHERS AND 1/2" - 13 TPI GRADE 5 (MINIMUM) HEX NUTS AS SHOWN. MUST USE DOUBLED HEX NUT CONFIGURATION ABOVE CEILING ANCHORS. SINGLE HEX NUT BENEATH HANGING ANGLE IS ACCEPTABLE FOR FULL LENGTH HANGING ANGLES. MAINTAIN 1/4" OF EXPOSED THREADS BENEATH BOTTOM HEX NUT. TORQUE ALL HEX NUTS TO 57 FT-LBS.

SUPPLY PLENUM HANGING ANGLE (HARDWARE BY INSTALLER)

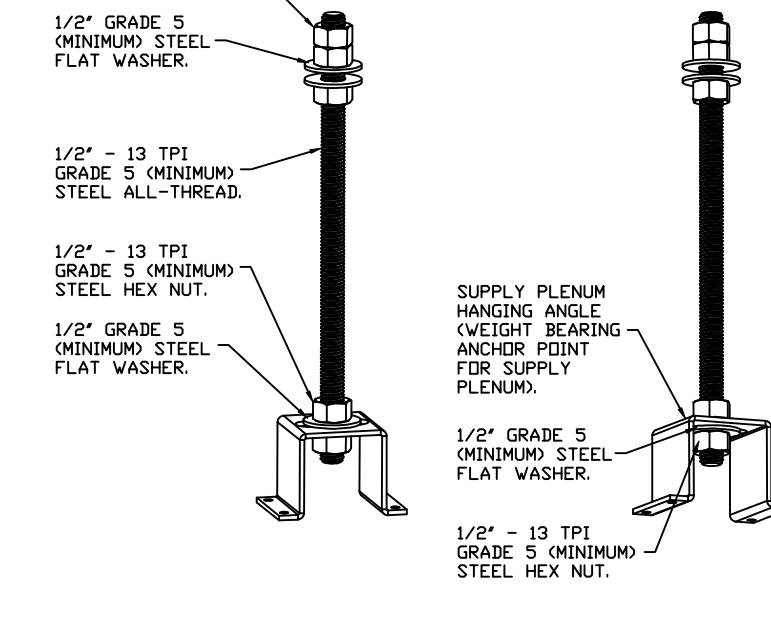

ASSEMBLY INSTRUCTIONS

HANGING ANGLE MUST BE SUPPORTED WITH 1/2" - 13 TPI GRADE 5 (MINIMUM) ALL-THREAD. SANDWICH HANGING ANGLES AND CEILING ANCHOR POINTS WITH 1/2" GRADE 5 (MINIMUM) STEEL FLAT WASHERS AND 1/2" - 13 TPI GRADE 5 (MINIMUM) HEX NUTS AS SHOWN. MUST USE DOUBLED HEX NUT CONFIGURATION ABOVE CEILING ANCHORS. SINGLE HEX NUT BENEATH HANGING ANGLE IS ACCEPTABLE FOR PSP HANGING ANGLES. MAINTAIN 1/4" OF EXPOSED THREADS BENEATH BOTTOM HEX NUT. TORQUE ALL HEX NUTS TO 57 FT-LBS.

REVISIONS

| DESCRIPTION | DATE: |
|-------------|-------|
| | |
| | |
| | |
| | |

CAPTIVEAIRE

Highwoods Group
www.captivair.com
4641 Paragon Park Rd., Raleigh, NC 27616 PHONE: (919) 875 - 0420 FAX: 9198750577 EMAIL: reg40@captivair.com

CHIPOTLE EAST MELBOURNE #5337
INDIAN HARBOR BEACH, FL, 32937

DATE: 9/10/2024
DWG.#: 7032765
DRAWN BY: JMB-40
SCALE: 3/4" = 1'-0"
MASTER DRAWING

SHEET NO.
1

FIRE SYSTEM INFORMATION - JOB#7032765

| FIRE SYSTEM NO | TAG | TYPE | SIZE | MAX FP | DESIGN FP | INSTALLATION | |
|----------------|-----|---------|---------|--------|-----------|--------------------|------------------|
| | | | | | | SYSTEM | LOCATION ON HOOD |
| 1 | | TANK FS | 4.0/4.0 | 40 | 32 | FIRE CABINET RIGHT | RIGHT, HOOD 1 |

GAS VALVE(S)

| FIRE SYSTEM NO | TAG | TYPE | SIZE | SUPPLIED BY |
|----------------|-----|---------------|-------|--------------------|
| 1 | | SC ELECTRICAL | 1.500 | CAPTIVEAIR SYSTEMS |

FIRE SYSTEM PARTS LIST KEY

| FIRE SYSTEM NO | TAG | KEY NUMBER - PART DESCRIPTION | QTY BY FACTORY | QTY BY DIST |
|----------------|-----|---|----------------|-------------|
| 1 | | 0 - 0 - TANK FIRE SUPPRESSION POST-DISCHARGE PROCEDURE UTILITY CABINET LABEL SHEET. | 1 | 0 |
| | | 0 - 0 - TANK FIRE SUPPRESSION MAINTENANCE GUIDE UTILITY CABINET LABEL SHEET. | 1 | 0 |
| | | 0 - 0 - 12-F28021-32144-DT-360 DUCT FIRE THERMOSTAT WITH 12 FOOT WIRE LEADS. ND, CLOSE ON TEMP RISE AT 360°F. (A0034310). | 1 | 0 |
| | | 0 - 0 - 32-00002 QUIK SEAL - 1/2" (UL). | 1 | 0 |
| | | 0 - 0 - 4429K153 1/2" MALE NPT TO 1/2" FEMALE NPT ELBOW, BRASS. | 2 | 0 |
| | | 0 - 0 - 4429K422 1/2" X 1/4" BRASS REDUCING BUSHING. | 1 | 0 |
| | | 0 - 0 - 79525 1/2" 90 PRO-PRESS ELBOW WITH 1/2" NPT FEMALE CONNECTION, VIEGA. | 1 | 0 |
| | | 0 - 0 - 79580 1/2" X 1/2" PRO-PRESS TEE X 1/2" NPT FEMALE CONNECTION, VIEGA. | 2 | 0 |
| | | 0 - 0 - 87-120042-001 SECONDARY ACTUATOR VALVE (SVA) - SINGLE ACTUATOR, REQUIRES PRIMARY RELEASE ACTUATOR, TANK FIRE SUPPRESSION. | 1 | 0 |
| | | 0 - 0 - 87-120045-001 HOSE, SECONDARY ACTUATOR HOSE, 7.5' BRAIDED STAINLESS STEEL, TANK FIRE SUPPRESSION. | 1 | 0 |
| | | 0 - 0 - 87-300001-001 TANK - PRESSURIZED TANK USED FOR TANK FIRE SUPPRESSION. | 2 | 0 |
| | | 0 - 0 - 87-300030-001 PRIMARY ACTUATOR KIT (PAK) - ACTUATOR AND RELEASE SOLENOID ASSEMBLY, ONE NEEDED PER FIRE SYSTEM, SUPERVISED, TANK FIRE SUPPRESSION. | 1 | 0 |
| | | 0 - 0 - 87-300030-001 PRIMARY ACTUATOR KIT (PAK) - ACTUATOR AND RELEASE SOLENOID ASSEMBLY, ONE NEEDED PER FIRE SYSTEM, SUPERVISED, TANK FIRE SUPPRESSION. | 1 | 0 |
| | | 0 - 0 - 87-300152-001 HARDWARE, SVA BOLTS, TANK FIRE SUPPRESSION. | 8 | 0 |
| | | 0 - 0 - 9055455PC PRO PRESS 1/2 PRESS X PRESS 90 ELBOW LD. | 7 | 0 |
| | | 0 - 0 - 9097200PC PRO PRESS PC611 1/2 PRESS TEE LD. | 7 | 0 |
| | | 0 - 0 - 98694A115 HARDWARE, DATANKLOCK LOCKING BRACKET SQUARE NUTS 5/16" ZINC, TANK FIRE SUPPRESSION. | 4 | 0 |
| | | 0 - 0 - A0034332 JUNCTION BOX FOR MANUAL PULL STATION. 1.5" DEEP BACK BOX, RED COLOR. | 1 | 0 |
| | | 0 - 0 - A31484 1/4" NPT SCHRADER VALVE AND CAP, JB INDUSTRIES. 1/4" FLARE X 1/4" MPT HALF UNION. USED ON TANK SERVICE PORT. | 1 | 0 |
| | | 0 - 0 - B1145 3/8" BLACK IRON 90 ELL. | 3 | 0 |
| | | 0 - 0 - DATANKLOCK DISCHARGE ADAPTER TANK LOCKING PLATE FOR FIRE SYSTEM TANK INSTALLATION IN UTILITY CABINETS, TANK FIRE SUPPRESSION. | 2 | 0 |
| | | 0 - 0 - TANK STRAP TANK STRAP - USED FOR TANK FIRE SUPPRESSION. | 6 | 0 |
| | | 0 - 0 - TFS-UCTANKBRACKET TANK BRACKET FOR FIRE SYSTEM TANK INSTALLATION IN UTILITY CABINETS, TANK FIRE SUPPRESSION. | 2 | 0 |
| | | 0 - 0 - WK-283952-000 DISCHARGE ADAPTER, TANK FIRE SUPPRESSION. | 2 | 0 |
| | | 16 - 16 - 79210 1/2" X 3/8" NPT MALE ADAPTER, VIEGA. | 8 | 0 |
| | | 16 - 16 - DL-F NOZZLE - TANK PROTECTION APPLIANCE COVERAGE NOZZLE (INCLUDES METAL BLOW OFF CAP, LANYARD, USED WITH CHROME-PLATED PIPE). | 8 | 0 |
| | | 26 - 26 - QSA-3/8 QUIK SEAL - 3/8" (UL). | 8 | 0 |
| | | 34 - 34 - A0034331 24VDC SINGLE ACTION MANUAL ACTUATION DEVICE (PUSH/PULL STATION) WITH PROTECTIVE COVER, ONE (1) NORMALLY OPEN CONTACT. RED COLOR. | 1 | 0 |

| REVISIONS | |
|-------------|-------|
| DESCRIPTION | DATE: |
| | |
| | |
| | |
| | |

Highwoods Group
4641 Paragon Park Rd., Raleigh, NC 27616 PHONE: (919) 875 - 0420 FAX: 9198750577 EMAIL: reg40@captivair.com

CHIPOTLE EAST MELBOURNE #5337
 INDIAN HARBOR BEACH, FL, 32937

| |
|----------------------------|
| DATE: 9/10/2024 |
| DWG.#: 7032765 |
| DRAWN BY: JMB-40 |
| SCALE: 3/4" = 1'-0" |
| MASTER DRAWING |

SHEET NO.
3

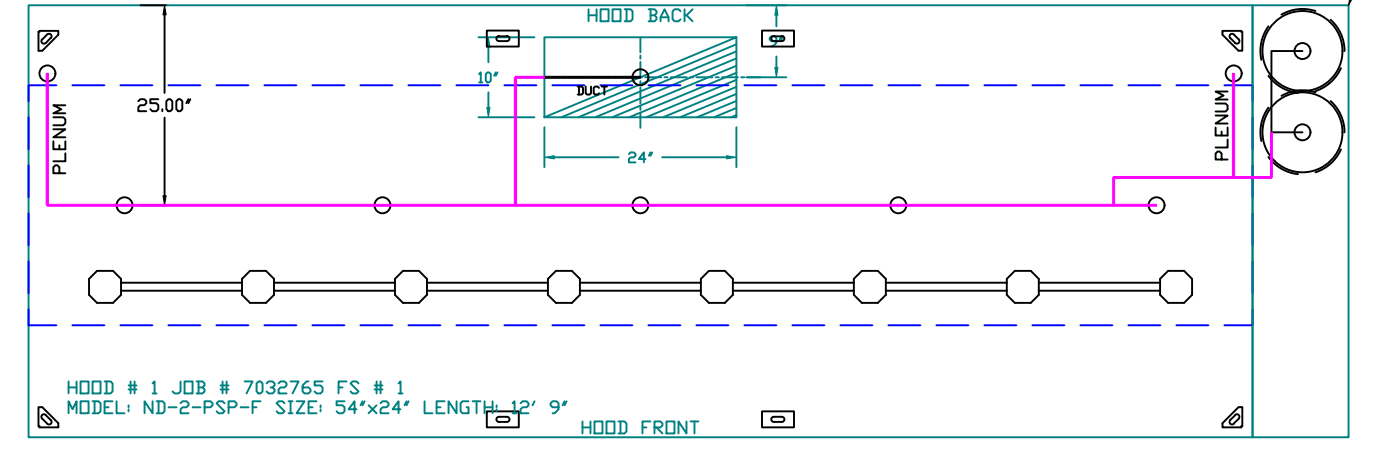

SYSTEM REQUIRES A MINIMUM OF 7 FT OF EQUIVALENT PIPE LENGTH BETWEEN TANK AND NEAREST APPLIANCE NOZZLE FOR MOST APPLIANCES. EACH 90 DEGREE ELBOW ADDS 1.5 FT OF EQUIVALENT LENGTH. SEE MANUAL FOR DETAILS.

- NOTES
- FIELD PIPE DROPS AS SHOWN.
 - PIPING, ELBOWS, TEES, AND NOZZLES SUPPLIED BY CAS.
 - FIELD INSTALLED DROP: FACTORY WILL PROVIDE QTY 2 60IN LONG PIECES OF CHROME PLATED PIPING SHIPPED LOOSE TO BE FIELD-INSTALLED.
 - SHIP LOOSE DROP: FACTORY WILL PROVIDE THE EXACT CHROME PIPE LENGTH NEEDED SHIPPED LOOSE TO BE FIELD-INSTALLED.
 - RELOCATE NOZZLES IF FLOW PATTERN IS BLOCKED BY SHELVING, SALAMANDERS, ETC.
 - OVERLAPPING COVERAGE SHALL NOT BE USED ON ANY APPLIANCE WITH AN OBSTRUCTION.
 - IF APPLICABLE, EXTENDED PRE-PIPED DROPS ARE SHIPPED LOOSE.
 - FACTORY PIPING EXTENDS A MAXIMUM OF 6' ABOVE THE TOP OF THE HOOD.

INCLUDES: FIELD INSTALLATION AND HOOKUP DURING NORMAL BUSINESS HOURS BY CERTIFIED INSTALLERS ONLY IN THE LOCATION NOTED ABOVE. TWO SITE VISITS ONLY (ONE VISIT TO SET PULL STATION & SYSTEM HOOKUP AND ONE VISIT FOR DNE TEST). ADDITIONAL VISITS WILL RESULT IN ADDITIONAL CHARGES. ONE MECHANICAL OR ELECTRICAL GAS VALVE PER SYSTEM AT A MAXIMUM SIZE OF 2". PERMIT, AND SYSTEM TEST. EXCLUDES: UNION LABOR & PREVAILING WAGE (LABOR & WAGES WILL BE ADDED IF APPLICABLE), GAS VALVE INSTALLATION, ELECTRICAL HOOKUP AND CONNECTIONS, HANGING OF FIRE CABINET, SHUNT TRIP, HANDHELD EXTINGUISHER(S), ON-SITE RE-PIPING DUE TO EQUIPMENT LAYOUT CHANGES.

- APPLIANCE DIMENSIONS LISTED REPRESENT THE COOKING SURFACE SIZE, NOT THE OVERALL APPLIANCE SIZE.
- THIS FIRE SYSTEM COMPLIES WITH UL 300 REQUIREMENTS.

- DL-F NOZZLE PART NUMBER REPLACES 3070-3/8H-10-SS
 JOB #: 7032765
 JOB NAME: CHIPOTLE EAST MELBOURNE #5337.

SYSTEM SIZE: TANK-SP-2 DESIGN FP: 32. MAXIMUM FP: 40.
 HOOD # 1 12' 9.00' LONG x 54' WIDE x 24' HIGH.
 RISER # 1 SIZE: 10" x 24".
 HOOD # 1 METAL BLOW-OFF CAPS INCLUDED.

- HEAVY-DUTY APPLIANCES (RATED 600°F) WILL REQUIRE AN ADDITIONAL DOWNSTREAM FIRESTAT IN THE EVENT THAT THE DUCTWORK CONTAINS ANY HORIZONTAL RUNS OVER 25 FT IN LENGTH.
- MEDIUM TO LIGHT-DUTY APPLIANCES (RATED 450°F) WILL NOT REQUIRE ANY ADDITIONAL DOWNSTREAM DETECTION.

| AGENT DISTRIBUTION PIPING LIMITATIONS | |
|---|----------------------|
| PIPE SECTION | MAX PIPE LENGTH (FT) |
| MAX SUPPLY LINE TO FIRST OVERLAPPING NOZZLE | 42 |
| OVERLAPPING NOZZLE APPLIANCE BRANCH | 10 |
| DEDICATED NOZZLE APPLIANCE BRANCH | 10 |

LEGEND - FIRE CABINET TANK SYSTEM

- 4 GALLON TANK.
- PRIMARY ACTUATOR RELEASE.
- SECONDARY ACTUATOR RELEASE.
- PRESSURE SUPERVISION SWITCH.
- PRIMARY HOSE ASSEMBLY.
- SECONDARY HOSE ASSEMBLY.
- REMOTE MANUAL ACTUATION DEVICE.

FACTORY PIPING EXTENDS A MAXIMUM OF 6' ABOVE THE TOP OF THE HOOD.

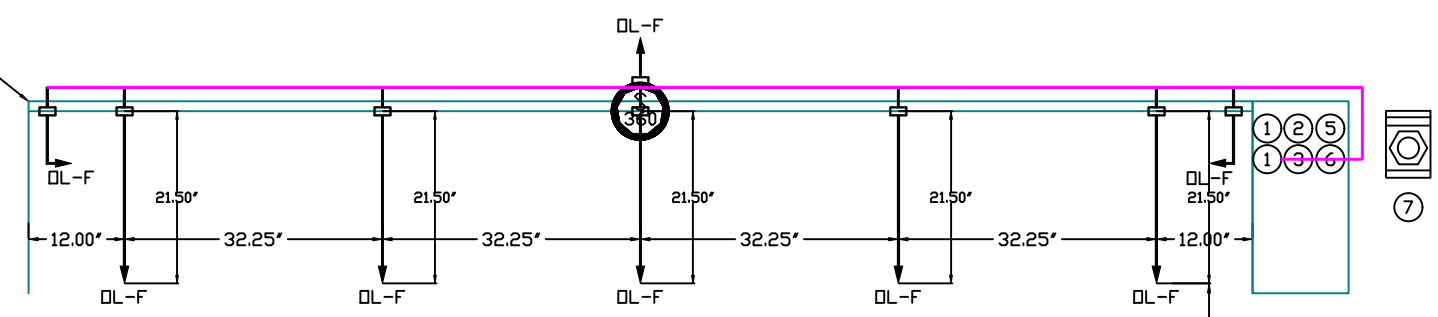

NOZZLE HEIGHT
 35-50' FROM
 COOKING SURFACE.
 (45.25')

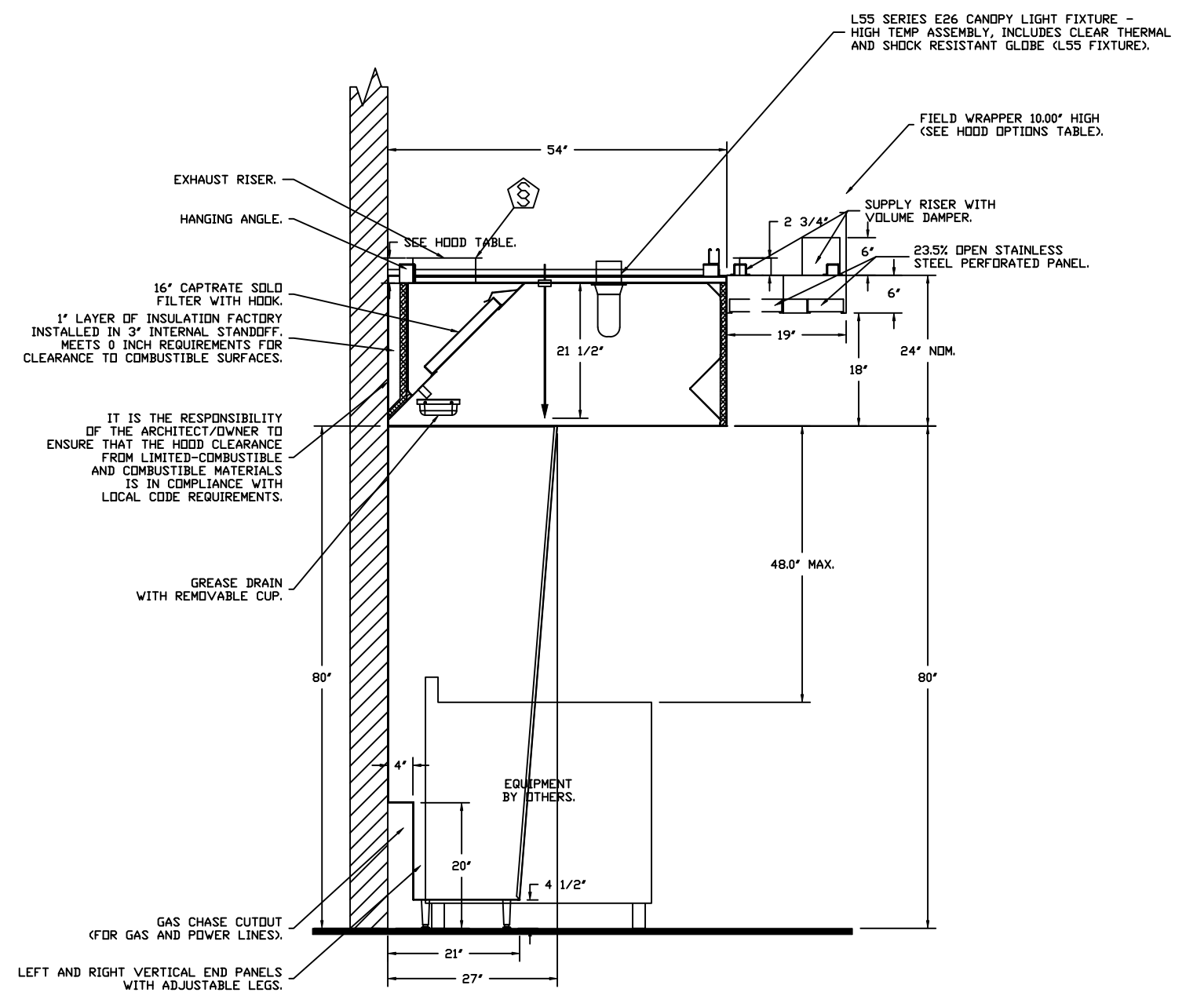
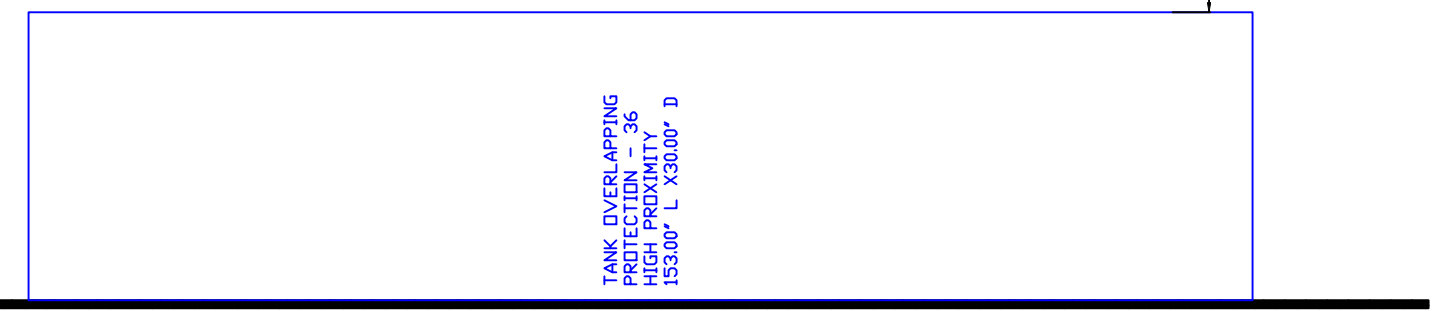

SECTION VIEW - MODEL 5424ND-2-ACPSP-F
 HOOD - #1

| GAS VALVES AND STRAINERS | | | | | | | | | | | | | | | | | |
|--------------------------|--------|---------|---------------------|-----------------------|------------------------------------|----------------------|---------|---------|---------|---------|---------|--------------|----------------------|-----------------------|----------------------|------------------------|--|
| TYPE | SIZE | VOLTAGE | GAS VALVE SIZING | | | GAS VALVE DIMENSIONS | | | | | | INSTALLATION | | | PART NUMBERS | | |
| | | | MIN. INLET PRESSURE | MAX. INLET PRESSURE | FLOW AT 1 IN.W.C. DROP NATURAL GAS | DIM "A" | DIM "B" | DIM "C" | DIM "D" | DIM "E" | DIM "F" | DIM "G" | MOUNTING ORIENTATION | GAS VALVE PART NUMBER | STRAINER PART NUMBER | GAS VALVE/STRAINER KIT | |
| ELECTRICAL | 1-1/2" | 24 VDC | 0 PSIG (0 IN.W.C.) | 5 PSIG (1.38 IN.W.C.) | 2,400,000 BTU/HR | 1.561,219 | 7-5/8" | 6-3/8" | 5-3/4" | 6-3/16" | 14-1/8" | 12-5/16" | HORIZONTAL | 8214275-24VDC | 4417967 | (S)C(S)E(C)I-1/2-24 | |

ELECTRIC GAS VALVES ONLY:
 3/4"-2" 120VAC GAS VALVES CAN BE MOUNTED WITH THE SOLIDHOOD IN ANY POSITION ABOVE HORIZONTAL.
 2 1/2"-3" 120VAC GAS VALVES MUST BE MOUNTED WITH THE SOLIDHOOD VERTICAL AND UPRIGHT.
 24VDC GAS VALVES MUST BE MOUNTED WITH THE SOLIDHOOD VERTICAL AND UPRIGHT.

ALL GAS VALVES/STRAINERS:
 PROPER CLEARANCE MUST BE PROVIDED IN ORDER TO SERVICE THE STRAINERS A MINIMUM OF 4" CLEARANCE DISTANCE MUST BE PROVIDED AT THE BASE OF THE STRAINER CUSTOMER MUST VERIFY BTU CONSUMPTION AS WELL AS PRESSURE RATING, SPECIFIC GRAVITY OF NATURAL GAS = 0.64, SPECIFIC GRAVITY OF LP = 1.52.

CALCULATIONS:
 TO CALCULATE GAS FLOW FOR OTHER THAN 1 IN.W.C. PRESSURE DROP
 NEW BTU/HR = (BTU/HR AT 1 IN.W.C. PRESSURE DROP) X NEW PRESSURE DROP^{0.85}
 TO CALCULATE GAS FLOW FOR OTHER THAN 0.64 SPECIFIC GRAVITY
 NEW BTU/HR = (BTU/HR AT 0.64) X (0.64 / NEW SPECIFIC GRAVITY)^{0.85}

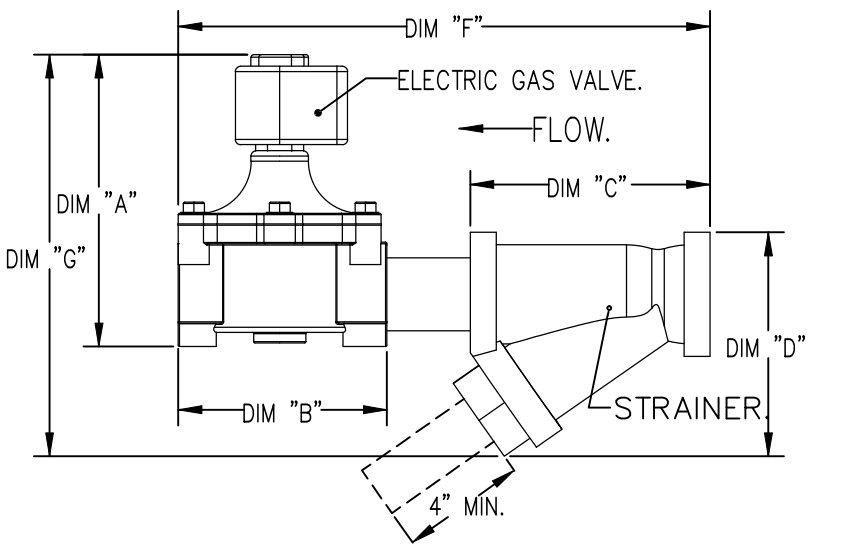

REVISIONS

| DESCRIPTION | DATE: |
|-------------|-------|
| | |
| | |
| | |
| | |
| | |

CAPTIVE

Highwoods Group
 www.captivevairs.com
 www.highwoodsgroup.com

CHIPOTLE EAST MELBOURNE #5337
 INDIAN HARBOR BEACH, FL, 32937

DATE: 9/10/2024
 DWG.#: 7032765
 DRAWN BY: JMB-40
 SCALE: 1/2" = 1'-0"
 MASTER DRAWING

SHEET NO.
 4

4641 Paragon Park Rd., Raleigh, NC, 27616 PHONE: (919) 975-0420 FAX: 9198750577 EMAIL: reg40@captivevairs.com

EXHAUST FAN INFORMATION – JOB#7032765

| FAN UNIT NO | TAG | QTY | FAN UNIT MODEL # | MANUFACTURER | CFM | ESP | RPM | MOTOR ENCL | HP | BHP | PHASE | VOLT | FLA | DISCHARGE VELOCITY | WEIGHT (LBS) | SDNES |
|-------------|------|-----|------------------|--------------|------|-------|------|--------------|-------|--------|-------|------|-----|--------------------|--------------|-------|
| 1 | EF-1 | 1 | DU180HFA | CAPTIVEAIRE | 2550 | 1.450 | 1220 | TEFC,PREMIUM | 2.000 | 1.2800 | 3 | 208 | 7.3 | 589 FPM | 199 | 16.6 |
| 2 | EF-2 | 1 | DR12HFA | CAPTIVEAIRE | 150 | 0.600 | 1282 | TEAO-ECM | 0.250 | 0.0940 | 1 | 115 | 2.9 | | 53 | 6.1 |

MUA FAN INFORMATION – JOB#7032765

| FAN UNIT NO | TAG | QTY | FAN UNIT MODEL # | BLOWER | HOUSING | MIN CFM | DESIGN CFM | ESP | RPM | MOTOR ENCL | HP | BHP | PHASE | VOLT | FLA | MCA | MOCP | WEIGHT (LBS) | SDNES |
|-------------|-------|-----|------------------|------------|----------|---------|------------|-------|------|-------------|-------|--------|-------|------|-----|------|------|--------------|-------|
| 3 | MAU-1 | 1 | A1-D.250-15D | 15MF-1-MDD | A1-D.250 | 1000 | 1300 | 0.500 | 1546 | DDP,PREMIUM | 1.000 | 0.5690 | 3 | 208 | 3.1 | 3.9A | 15A | 507 | 12.1 |

GAS FIRED MAKE-UP AIR UNIT(S)

| FAN UNIT NO | TAG | INPUT BTUs | OUTPUT BTUs | TEMP RISE | REQUIRED INPUT GAS PRESSURE | GAS TYPE | BURNER EFFICIENCY(%) |
|-------------|-------|------------|-------------|-----------|-----------------------------|----------|----------------------|
| 3 | MAU-1 | 48302 | 44438 | 32°F | 7 IN. W.C. - 14 IN. W.C. | NATURAL | 92 |

FAN OPTIONS

| FAN UNIT NO | TAG | QTY | DESCRIPTION |
|-------------|-------|-----|--|
| 1 | EF-1 | 1 | GREASE BOX |
| | | 1 | REMOVE HINGE KIT LABEL FROM THE FAN BASE |
| 2 | EF-2 | 1 | MIAMI DADE CERTIFICATION – NDA-1 ALUMINUM UPBLAST |
| | | 1 | 2 YEAR PARTS WARRANTY |
| 2 | EF-2 | 1 | I 12-BDD DAMPER |
| | | 1 | ECM WIRING PACKAGE – MANUAL DR 0-10VDC REFERENCE SPEED CONTROL –RTC- (TELCO MOTOR), CCW ROTATION |
| 3 | MAU-1 | 1 | MIAMI DADE CERTIFICATION – NDA-1 ALUMINUM DOWNBLAST 10 |
| | | 1 | 2 YEAR PARTS WARRANTY |
| 3 | MAU-1 | 1 | SIZE 1 TEMPERED COMMERCIAL DOWN DISCHARGE FOR DIRECT DRIVE AHUS |
| | | 1 | INLET PRESSURE GAUGE, 0-35" |
| | | 1 | MANIFOLD PRESSURE GAUGE, -5 TO 15" WC |
| | | 1 | SHIP LOOSE GAS STRAINER 3/4" |
| | | 1 | MOTORIZED BACKDRAFT DAMPER FOR A1-D HOUSING – MEETS AMCA CLASS 1A RATING |
| | | 1 | MIAMI DADE CERTIFICATION – NDA-2 SUPPLY |
| | | 1 | SEPARATE 120V WIRING PACKAGE (REQUIRED AND USED ONLY FOR DCV OR PREWIRE WITH VFD) – THREE PHASE ONLY |
| | | 1 | 2 YEAR PARTS WARRANTY |
| | | 1 | EXTERIOR GAS CONNECTION PROVIDED BY FACTORY WITH QUICK SEAL AND ANTI-ROTATION BRACKET |

FAN ACCESSORIES

| FAN UNIT NO | TAG | EXHAUST | | | | SUPPLY | | | |
|-------------|-------|-------------|----------------|------------|----------------|----------------|------------------|------------|--|
| | | GRAVITY CUP | GRAVITY DAMPER | WALL MOUNT | SIDE DISCHARGE | GRAVITY DAMPER | MOTORIZED DAMPER | WALL MOUNT | |
| 1 | EF-1 | YES | | | | | | | |
| 2 | EF-2 | | YES | | | | | | |
| 3 | MAU-1 | | | | | | YES | | |

CURB ASSEMBLIES

| NO | ON FAN | TAG | WEIGHT | ITEM | SIZE |
|----|--------|-------|---------|------|--|
| 1 | # 1 | EF-1 | 50 LBS | CURB | 26.500"W X 26.500"L X 26.000"H VENTED 16 GAUGE. |
| 2 | # 2 | EF-2 | 51 LBS | CURB | 17.500"W X 17.500"L X 26.000"H 16 GAUGE. |
| 3 | # 3 | MAU-1 | 108 LBS | CURB | 21.000"W X 71.000"L X 20.000"H INSULATED 16 GAUGE. |

| HMI SCHEDULE | | | | |
|--------------|---------------|--------------|----------------|----------------|
| UNIT NUMBER | HMI # | HMI LOCATION | TEMP AVERAGING | MODBUS ADDRESS |
| FAN #3 | HMI #1 – UNIT | IN UNIT | NOT AVERAGED | 55 |

Miami-Dade NDA2 Supply Fans

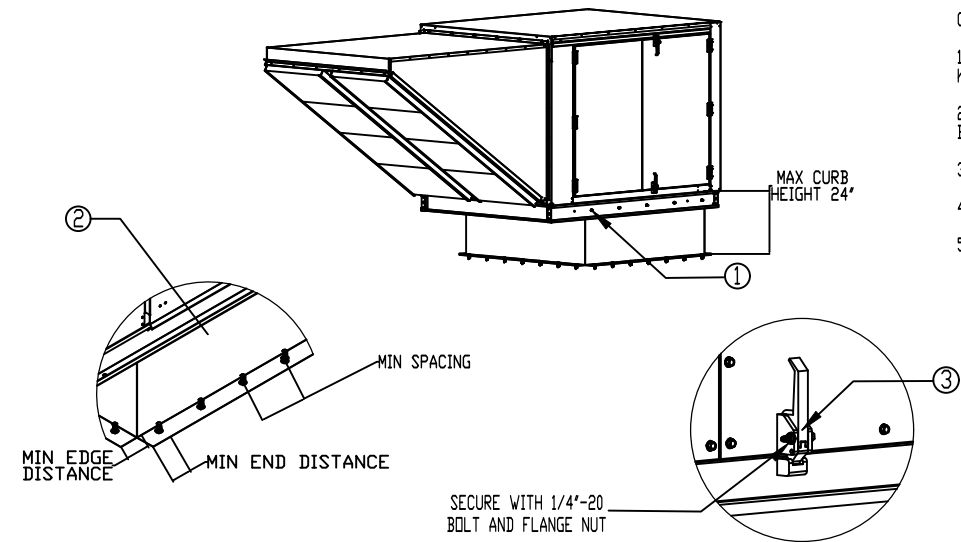

General Notes

- This approval is for the structural capacity and impact rating of the exterior housing only; it does not include any interior mechanism or electrical part.
- These fans have not been wind tested for Wind Driven Rain Test per Florida Building Code, TAS300 (A)-95.
- Tested in accordance to Florida Building Code test protocol TAS201, TAS202, TAS203.
- Tested for areas including high velocity hurricane zones.
- Tested under Miami-Dade County Notification number ATI-08033.

- INSTALLATION INSTRUCTIONS:
1. SECURE LID TO FAN USING (5) 1/4" X 1/4" ZINC PLATED SELF DRILLING SCREW (ELCO DRIL-FLEX OR BETTER) THROUGH FAN WALLS. SEE TABLE BELOW FOR QTY.
- SECURE FAN BASE TO CURB USING (12) 5/16" X 2" GALVANIZED SELF DRILLING SCREWS (ELCO DRIL-FLEX OR BETTER) THROUGH PRE-PUNCHED HOLES IN THE FAN BASE. SEE TABLE BELOW FOR QTY.
- SECURE CURB TO ROOF OR WALL BY DRILLING 1/4" DIA PILOT HOLES IN THE CURB FLANGE AT LOCATIONS SHOWN IN THE DIAGRAM SEE TABLE BELOW FOR FASTENER TYPE, USE TABLE BELOW FOR FASTENER QTY.

DESIGN PRESSURE: +100 / -100 PSF
LARGE MISSILE IMPACT RESISTANT

| INSTALLATION FASTENER TYPES | | | | | | | | | | | |
|-----------------------------|---|---|--------------------------------|--|--|--|---|--|--|--|--|
| Fan To Curb | Door to Frame | | Wood (50 = 0.42 Min.) | | Steel (12 Gauge Min.) | | Concrete (2500 psi Min. Cracked Concrete) | | | | |
| Fastener | 5/16" x 1-1/2" Self Drilling Screw (ELCO DRIL-FLEX OR BETTER) | 1/4" x 1/4" x 2" Self Drilling Screw (ELCO DRIL-FLEX OR BETTER) | 3/8" Dia. Zinc Plated Lag Bolt | 1/4" x 1/4" Dri-Flex Self Drilling Screw | 3/8" Dia. SS Hilti Kwik Bolt T2 Expansion Anchor | 3/8" Dia. SS Hilti Kwik Bolt T2 Expansion Anchor | | | | | |
| Minimum Thread Penetration | N/A | 2" | 2" | 12 Gauge | 2-5/16" | 2-5/16" | | | | | |
| Minimum Edge Distance | N/A | N/A | 1-1/2" | 3/8" | 3" | 3" | | | | | |
| Minimum End Distance | N/A | 1-1/2" | 2-5/8" | 3/8" | 4" | 4" | | | | | |
| Minimum Spacing | N/A | See Table | 1-1/2" | 3/4" | 3" | 3" | | | | | |

| INSTALLATION FASTENER QTY | | | | | | | | | | | | |
|---------------------------|-------------|------------|-------|-----------|------------|-------|-----------|----------|-----------|------------|-------|----|
| FAN MODEL | CURB TO FAN | | | WOOD | | | STEEL | | CONCRETE | | | |
| | LONG SIDE | SHORT SIDE | TOTAL | LONG SIDE | SHORT SIDE | TOTAL | LONG SIDE | PER SIDE | LONG SIDE | SHORT SIDE | TOTAL | |
| Direct Fired 1 | 5 | 2 | 14 | 8 | 3 | 22 | 6 | 2 | 16 | 7 | 2 | 18 |

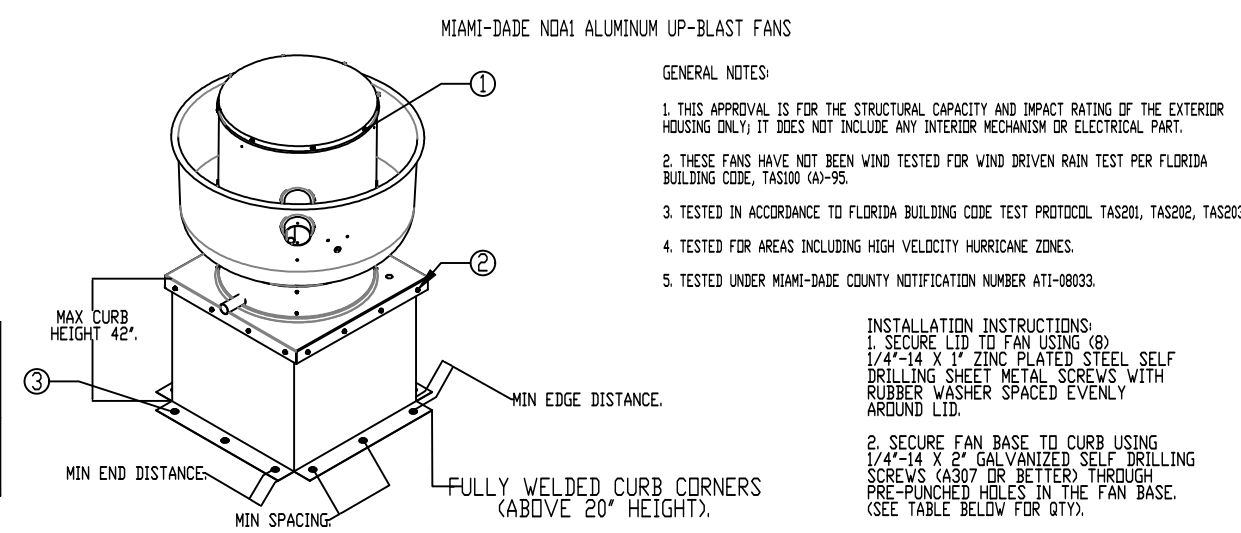

GENERAL NOTES

- This approval is for the structural capacity and impact rating of the exterior housing only; it does not include any interior mechanism or electrical part.
- These fans have not been wind tested for Wind Driven Rain Test per Florida Building Code, TAS300 (A)-95.
- Tested in accordance to Florida Building Code test protocol TAS201, TAS202, TAS203.
- Tested for areas including high velocity hurricane zones.
- Tested under Miami-Dade County Notification number ATI-08033.

- INSTALLATION INSTRUCTIONS:
1. SECURE LID TO FAN USING (5) 1/4" X 1/4" ZINC PLATED SELF DRILLING SCREW (ELCO DRIL-FLEX OR BETTER) THROUGH FAN WALLS. SEE TABLE BELOW FOR QTY.
- SECURE FAN BASE TO CURB USING (12) 5/16" X 2" GALVANIZED SELF DRILLING SCREWS (ELCO DRIL-FLEX OR BETTER) THROUGH PRE-PUNCHED HOLES IN THE FAN BASE. SEE TABLE BELOW FOR QTY.
- SECURE CURB TO ROOF OR WALL BY DRILLING 1/4" DIA PILOT HOLES IN THE CURB FLANGE AT LOCATIONS SHOWN IN THE DIAGRAM SEE TABLE BELOW FOR FASTENER TYPE, USE TABLE BELOW FOR FASTENER QTY.

| INSTALLATION FASTENER TYPES | | | | | | | | | | | |
|-----------------------------|---|--------------------------------|--|--|---|--|--|--|--|--|--|
| FAN TO CURB | WOOD (50 = 0.42 MIN.) | | STEEL (12 GAUGE MIN.) | | CONCRETE (2500 PSI MIN. CRACKED CONCRETE) | | | | | | |
| FASTENER | 5/16" x 2" SELF DRILLING SCREW (ELCO DRIL-FLEX OR BETTER) | 3/8" DIA. ZINC PLATED LAG BOLT | 1/4" x 1/4" DRI-FLEX SELF DRILLING SCREW | 3/8" DIA. SS HILTI KWIK BOLT T2 EXPANSION ANCHOR | | | | | | | |
| MINIMUM THREAD PENETRATION | N/A | 2-1/2" | 12 GAUGE | 2" | | | | | | | |
| MINIMUM EDGE DISTANCE | N/A | 1-1/2" | 3/8" | 3" | | | | | | | |
| MINIMUM END DISTANCE | N/A | 2-5/8" | 3/8" | 3" | | | | | | | |
| MINIMUM SPACING | N/A | 1-1/2" | 3/4" | 5-1/2" | | | | | | | |

| INSTALLATION FASTENER QTY | | | | | | | | | | | | |
|---------------------------|-------------|-------|-----------|----------|-------|----------|-------|----------|----------|----------|-------|----|
| FAN MODEL | CURB TO FAN | | | WOOD | | | STEEL | | CONCRETE | | | |
| | PER SIDE | TOTAL | LONG SIDE | PER SIDE | TOTAL | PER SIDE | TOTAL | PER SIDE | TOTAL | PER SIDE | TOTAL | |
| Direct | 3 | 12 | 3 | 12 | 3 | 20 | 6 | 24 | 6 | 24 | 3 | 20 |

MIAMI-DADE COUNTY – WALL CURB INSTALLATION GUIDE

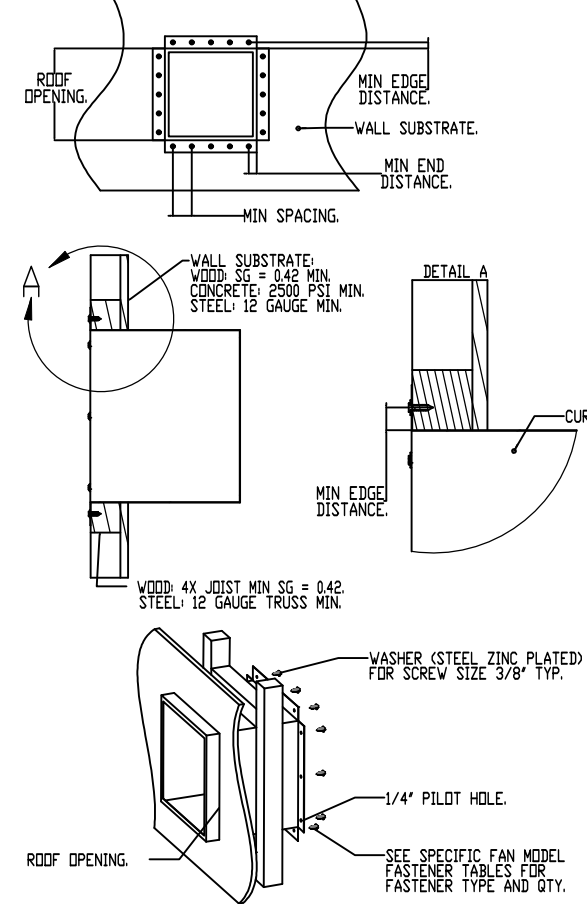

MIAMI-DADE NDA1 ALUMINUM DOWN-BLAST FANS

GENERAL NOTES

- This approval is for the structural capacity and impact rating of the exterior housing only; it does not include any interior mechanism or electrical part.
- These fans have not been wind tested for Wind Driven Rain Test per Florida Building Code, TAS300 (A)-95.
- Tested in accordance to Florida Building Code test protocol TAS201, TAS202, TAS203.
- Tested for areas including high velocity hurricane zones.
- Tested under Miami-Dade County Notification number ATI-08033.

- INSTALLATION INSTRUCTIONS:
1. SECURE LID TO FAN USING (5) 1/4" X 1/4" ZINC PLATED SELF DRILLING SCREW (ELCO DRIL-FLEX OR BETTER) THROUGH FAN WALLS. SEE TABLE BELOW FOR QTY.
- SECURE FAN BASE TO CURB USING (12) 5/16" X 2" GALVANIZED SELF DRILLING SCREWS (ELCO DRIL-FLEX OR BETTER) THROUGH PRE-PUNCHED HOLES IN THE FAN BASE. SEE TABLE BELOW FOR QTY.
- SECURE CURB TO ROOF OR WALL BY DRILLING 1/4" DIA PILOT HOLES IN THE CURB FLANGE AT LOCATIONS SHOWN IN THE DIAGRAM SEE TABLE BELOW FOR FASTENER TYPE, USE TABLE BELOW FOR FASTENER QTY.

| INSTALLATION FASTENER TYPES | | | | | | | | | | | |
|-----------------------------|---|--------------------------------|--|--|---|--|--|--|--|--|--|
| FAN TO CURB | WOOD (50 = 0.42 MIN.) | | STEEL (12 GAUGE MIN.) | | CONCRETE (2500 PSI MIN. CRACKED CONCRETE) | | | | | | |
| FASTENER | 5/16" x 2" SELF DRILLING SCREW (ELCO DRIL-FLEX OR BETTER) | 3/8" DIA. ZINC PLATED LAG BOLT | 1/4" x 1/4" DRI-FLEX SELF DRILLING SCREW | 3/8" DIA. SS HILTI KWIK BOLT T2 EXPANSION ANCHOR | | | | | | | |
| MINIMUM THREAD PENETRATION | N/A | 2-1/2" | 12 GAUGE | 2" | | | | | | | |
| MINIMUM EDGE DISTANCE | N/A | 1-1/2" | 3/8" | 3" | | | | | | | |
| MINIMUM END DISTANCE | N/A | 2-5/8" | 3/8" | 3" | | | | | | | |
| MINIMUM SPACING | N/A | 1-1/2" | 3/4" | 5-1/2" | | | | | | | |

| INSTALLATION FASTENER QTY | | | | | | | | | | | | |
|---------------------------|-------------|-------|-----------|----------|-------|----------|-------|----------|----------|----------|-------|----|
| FAN MODEL | CURB TO FAN | | | WOOD | | | STEEL | | CONCRETE | | | |
| | PER SIDE | TOTAL | LONG SIDE | PER SIDE | TOTAL | PER SIDE | TOTAL | PER SIDE | TOTAL | PER SIDE | TOTAL | |
| Direct | 3 | 12 | 3 | 12 | 3 | 20 | 6 | 24 | 6 | 24 | 3 | 20 |

REVISIONS

| DESCRIPTION | DATE: |
|-------------|-------|
| | |
| | |
| | |
| | |



CHIPOTLE EAST MELBOURNE #5337
INDIAN HARBOR BEACH, FL, 32937

DATE: 9/10/2024

DWG.#:
7032765

DRAWN BY: JMB-40

SCALE:
3/4" = 1'-0"

MASTER DRAWING

SHEET NO.

FAN #1 DU180HFA - EXHAUST FAN (EF-1)

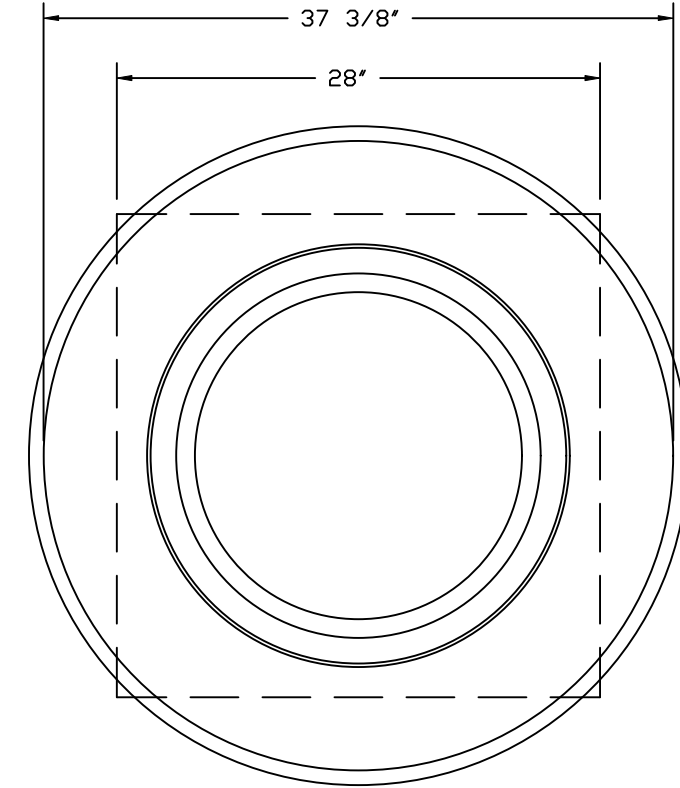
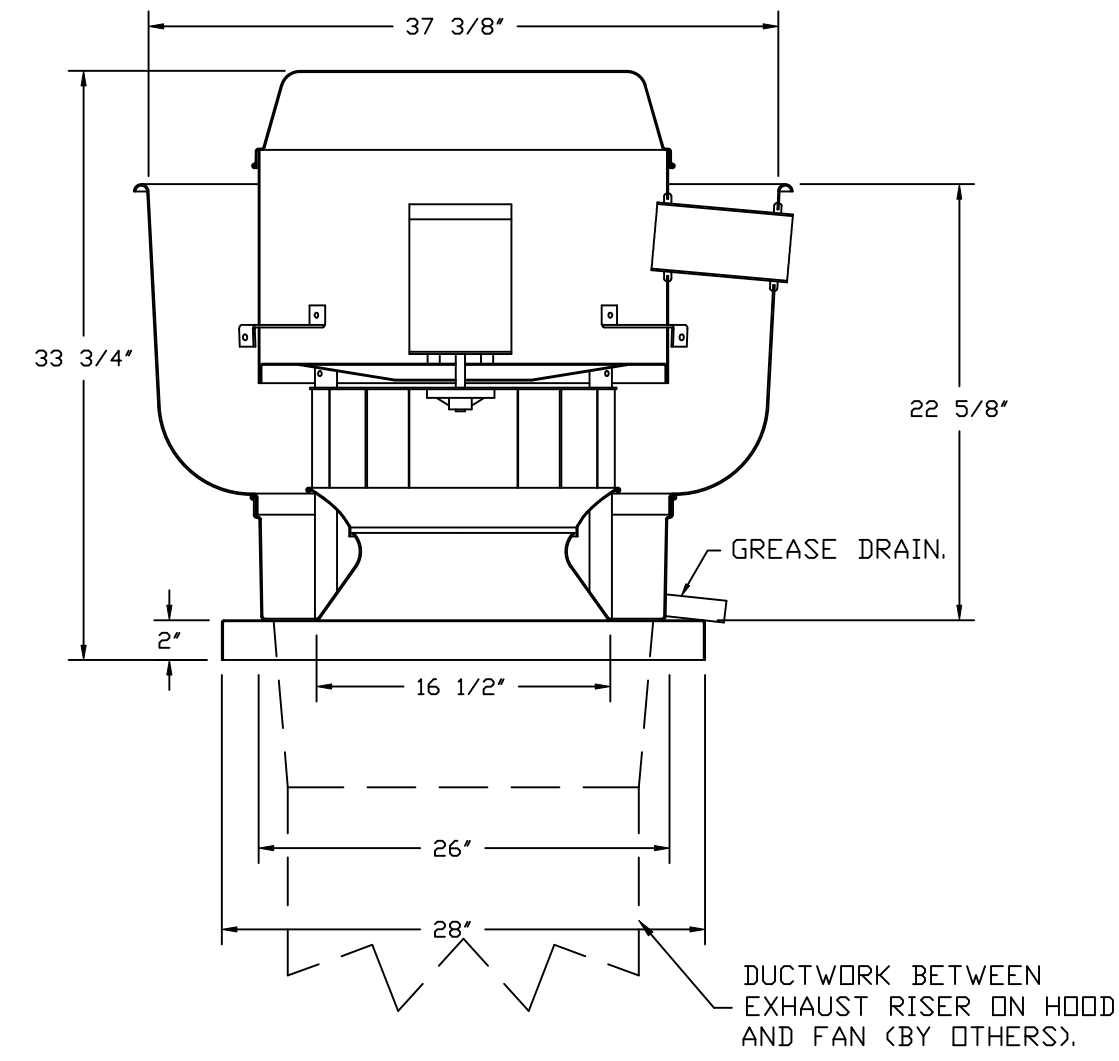

TOP VIEW

FEATURES:

- DIRECT DRIVE CONSTRUCTION (NO BELTS/PULLEYS).
- ROOF MOUNTED FANS.
- RESTAURANT MODEL.
- UL705 AND UL762 AND ULC-S645
- VARIABLE SPEED CONTROL.
- INTERNAL WIRING.
- THERMAL OVERLOAD PROTECTION (SINGLE PHASE).
- HIGH HEAT OPERATION 300°F (149°C).
- GREASE CLASSIFICATION TESTING.
- NEMA 3R SAFETY DISCONNECT SWITCH.

NORMAL TEMPERATURE TEST
EXHAUST FAN MUST OPERATE CONTINUOUSLY WHILE EXHAUSTING AIR AT 300°F (149°C) UNTIL ALL FAN PARTS HAVE REACHED THERMAL EQUILIBRIUM, AND WITHOUT ANY DETERIORATING EFFECTS TO THE FAN WHICH WOULD CAUSE UNSAFE OPERATION.

ABNORMAL FLARE-UP TEST
EXHAUST FAN MUST OPERATE CONTINUOUSLY WHILE EXHAUSTING BURNING GREASE VAPORS AT 600°F (316°C) FOR A PERIOD OF 15 MINUTES WITHOUT THE FAN BECOMING DAMAGED TO ANY EXTENT THAT COULD CAUSE AN UNSAFE CONDITION.

OPTIONS

- GREASE BDX.
- REMOVE HINGE KIT LABEL FROM THE FAN BASE.
- MIAMI DADE CERTIFICATION - NDA-1 ALUMINUM UPBLAST.
- 2 YEAR PARTS WARRANTY.

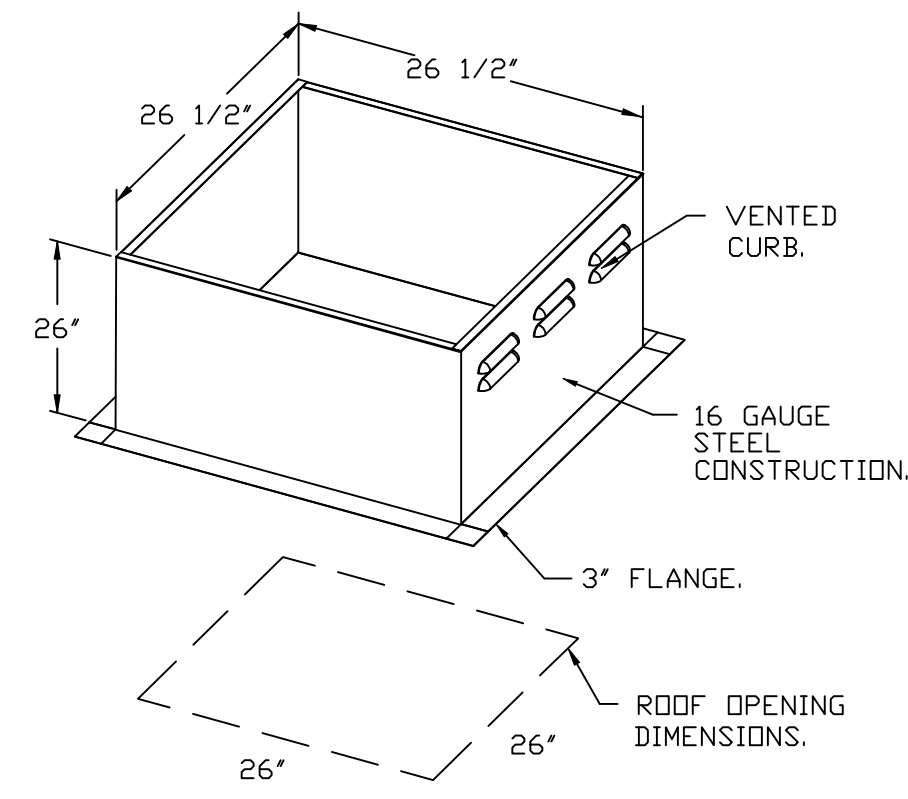

| REVISIONS | |
|-------------|-------|
| DESCRIPTION | DATE: |
| | |
| | |
| | |
| | |

www.captiveaire.com

Highwoods Group

4641 Paragon Park Rd., Raleigh, NC, 27616 PHONE: (919) 875 - 0420 FAX: 9198750577 EMAIL: reg40@captiveaire.com

CHIPOTLE EAST MELBOURNE #5337

INDIAN HARBOR BEACH, FL, 32937

| |
|----------------------------|
| DATE: 9/10/2024 |
| DWG.#: 7032765 |
| DRAWN BY: JMB-40 |
| SCALE: 3/4" = 1'-0" |
| MASTER DRAWING |

SHEET NO.

6

FAN #2_DR12HFA - EXHAUST FAN (EF-2)

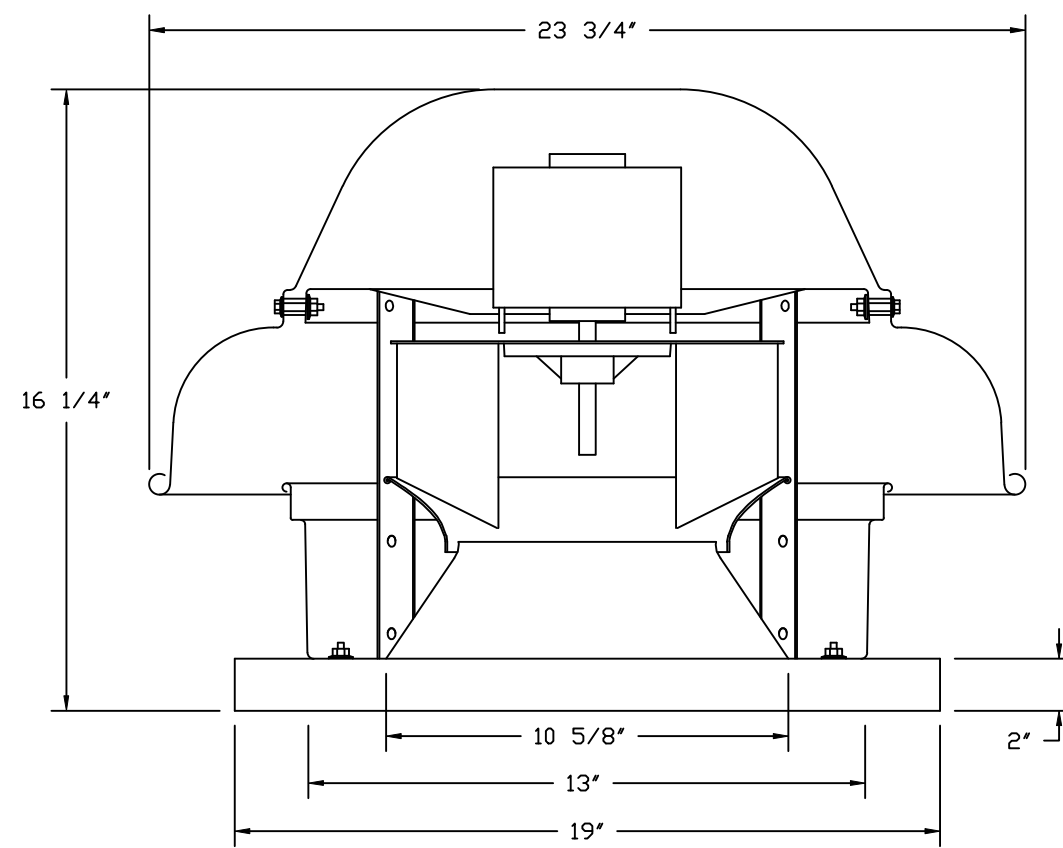

FEATURES:

- DIRECT DRIVE CONSTRUCTION (NO BELTS/PULLEYS).
- ROOF MOUNTED FANS.
- UL705.
- SAFETY DISCONNECT.
- STANDARD BIRD SCREEN.
- SPEED CONTROL.
- THERMAL OVERLOAD PROTECTION (SINGLE PHASE).

OPTIONS:

- 1 12-BDD DAMPER.
- ECM WIRING PACKAGE - MANUAL OR 0-10VDC REFERENCE SPEED CONTROL.
- RTC - (TELCO MOTOR), CCW ROTATION.
- MIAMI DADE CERTIFICATION - NDA-1 ALUMINUM DOWNBLAST 10.
- 2 YEAR PARTS WARRANTY.

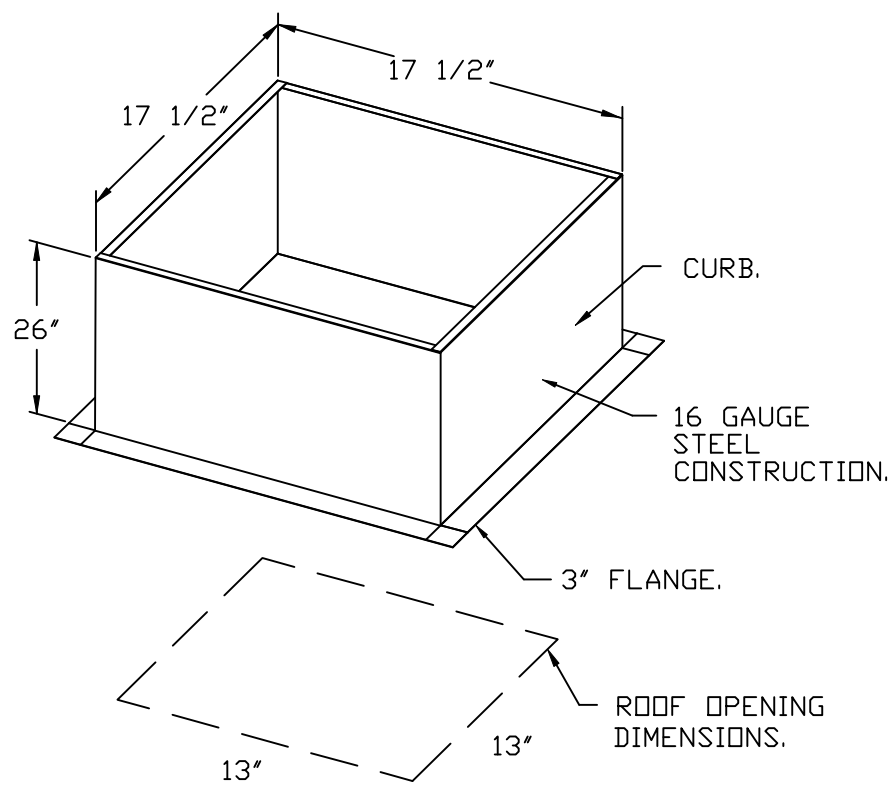

BACKDRAFT DAMPER INSTALLATION

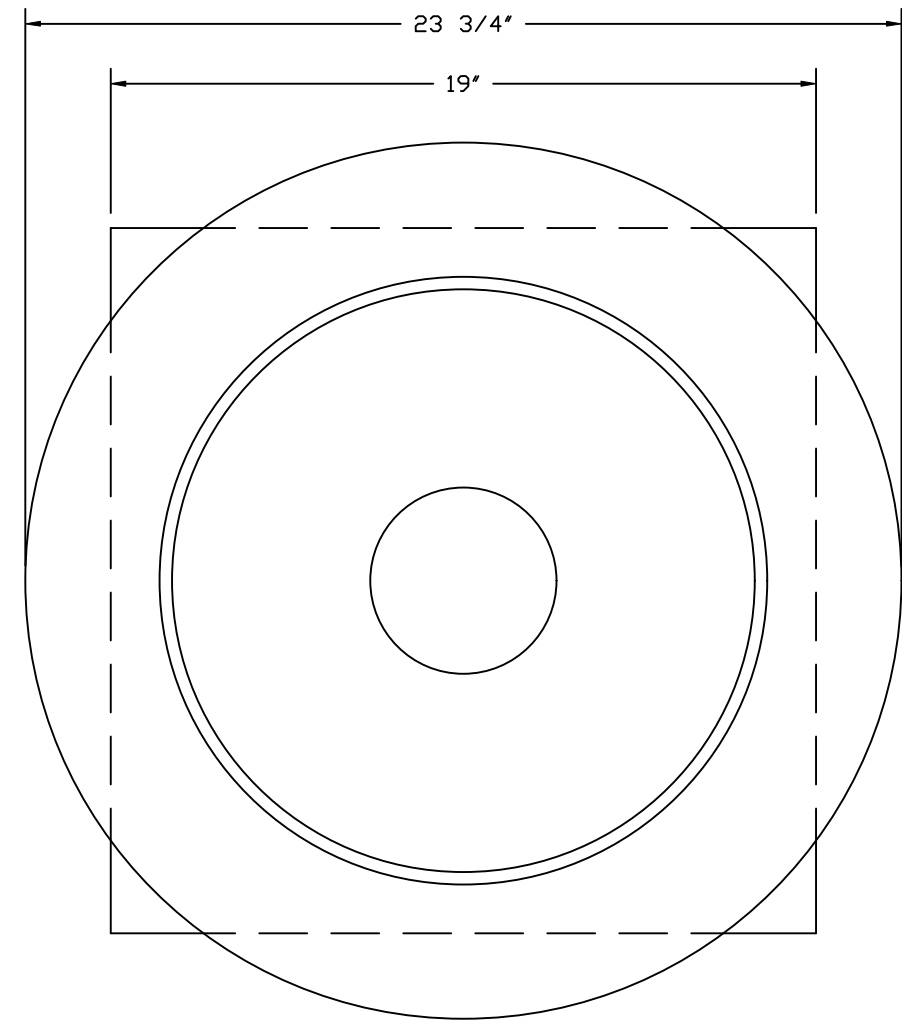
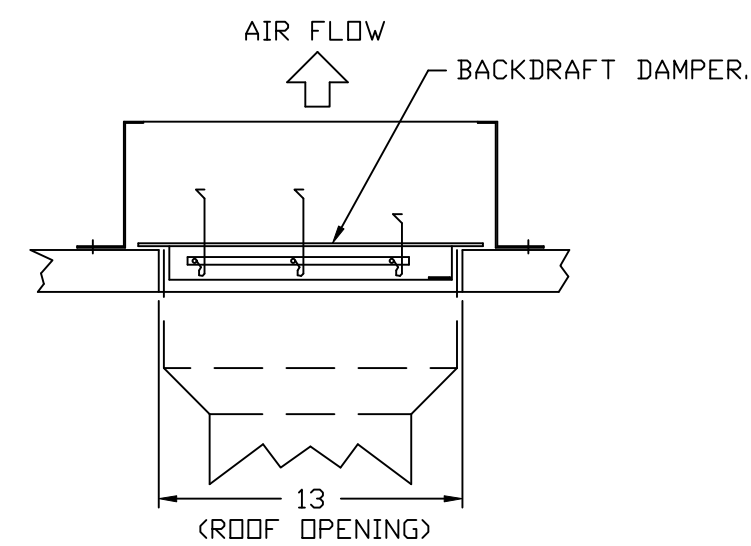

TOP VIEW

REVISIONS

| REVISION | DESCRIPTION | DATE |
|----------|-------------|------|
| △ | | |
| △ | | |
| △ | | |
| △ | | |

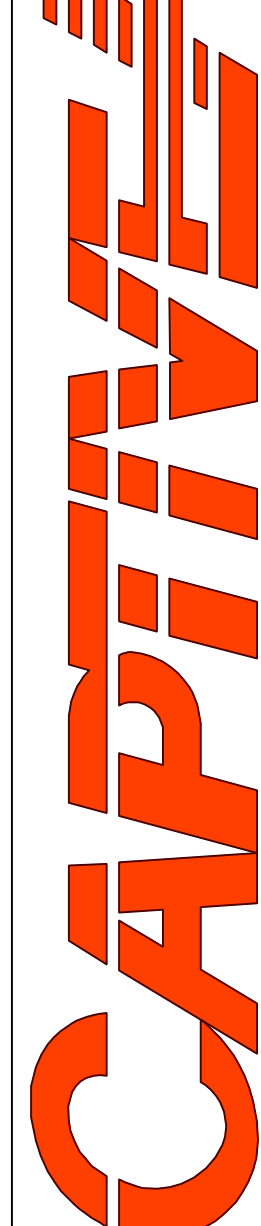
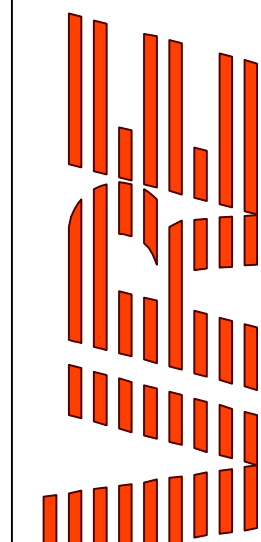
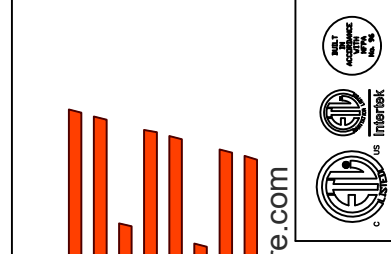

Highwoods Group

4641 Paragon Park Rd., Raleigh, NC, 27616 PHONE: (919) 875 - 0420 FAX: 9198750577 EMAIL: reg40@captiveaire.com

CHIPOTLE EAST MELBOURNE #5337
 INDIAN HARBOR BEACH, FL, 32937

DATE: 9/10/2024

DWG.#:
7032765

DRAWN BY: JMB-40

SCALE:
3/4" = 1'-0"

MASTER DRAWING

SHEET NO.
7

- FAN #3 AI-D250-1SD - HEATER (MAU-1)
1. DIRECT GAS FIRED HEATED MAKE UP AIR UNIT WITH 15" MIXED FLOW DIRECT DRIVE FAN.
 2. INTAKE HOOD WITH EZ FILTERS.
 3. DOWN DISCHARGE - AIR FLOW RIGHT -> LEFT.
 4. DOWN DISCHARGE CONSTRUCTION FOR SIZE 1 DIRECT DRIVE AHUS.
 5. GAS PRESSURE GAUGE, 0-35", 2.5" DIAMETER, 1/4" THREAD SIZE.
 6. GAS PRESSURE GAUGE, -5 TO +15 INCHES WC, 2.5" DIAMETER, 1/4" THREAD SIZE.
 7. SHIP LOOSE GAS STRAINER TO BE INSTALLED UPSTREAM OF UNIT CONNECTION, 3/4" CONNECTION.
 8. MODIFIED BACK DRAFT DAMPER 16" X 16" FOR SIZE 1 STANDARD & MODULAR HEATER UNITS W/EXTENDED SHAFT, STANDARD GALVANIZED CONSTRUCTION, 3/4" REAR FLANGE, LOW LEAKAGE, TFB20S ACTUATOR INCLUDED.
 9. MIAMI DADE IMPACT AND WIND LOAD CERTIFICATION +30 / -130 PSF - MIAMI DADE COUNTY PRODUCT CONTROL APPROVED. FLORIDA BUILDING CODE APPROVAL. ROOF MOUNT EXHAUST CURBS UP TO 20" HIGH MUST BE 18 GAUGE ALUMINIZED.
 10. SEPARATE 120VAC WIRING PACKAGE FOR MAKE-UP AIR UNITS. OPTION MUST BE SELECTED WHEN MOUNTING VFD IN PREWIRE PANEL OR WITH DCV PACKAGE. PROVIDES SEPARATE 120VAC INPUT TO SUPPLY FAN. THIS 120V SIGNAL MUST BE RUN BY ELECTRICIAN FROM DCV TO MUA SWITCH.
 11. HINGED DOUBLE WALL INSULATED DOOR ASSEMBLY (BURNER/BLOWER SECTION).
 12. EXTERIOR GAS CONNECTION PROVIDED BY FACTORY WITH QUICK SEAL AND ANTI-ROTATION BRACKET.
 13. 2 YEAR PARTS WARRANTY.

NOTE: SUPPLY DUCT MUST BE INSTALLED TO MEET SMACNA STANDARDS. A MINIMUM STRAIGHT DUCT LENGTH MUST BE MAINTAINED DOWNSTREAM OF UNIT DISCHARGE AS OUTLINED IN AMCA PUBLICATION 201. WHEN USING RECTANGULAR DUCTWORK, ELBOWS MUST BE RADIUS THROAT, RADIUS BACK WITH TURNING VANES. FLEXIBLE DUCTWORK AND SQUARE THROAT/SQUARE BACK ELBOWS SHOULD NOT BE USED. ANY TRANSITION AND/OR TURNS IN THE DUCTWORK WILL CAUSE SYSTEM EFFECT. SYSTEM EFFECT WILL DRAMATICALLY INCREASE STATIC PRESSURE AND REDUCE AIRFLOW. DO NOT RELY ON UNIT TO SUPPORT DUCT IN ANY WAY. FAILURE TO PROPERLY SIZE DUCTWORK MAY CAUSE SYSTEM EFFECTS AND REDUCE PERFORMANCE OF THE EQUIPMENT. SUGGESTED STRAIGHT DUCT SIZE IS 14" x 14".

SUPPLY SIDE HEATER INFORMATION:

WINTER TEMPERATURE = 43°F. TEMP. RISE = 32°F.
 BTUS CALCULATED OFF ACTUAL AIR DENSITY.
 OUTPUT BTUS AT ALTITUDE OF 0.0 FT. = 44443.
 INPUT BTUS AT ALTITUDE OF 0.0 FT. = 48308.
 OUTPUT BTUS AT ALTITUDE OF 3 FT. = 44438.
 INPUT BTUS AT ALTITUDE OF 3 FT. = 48302.

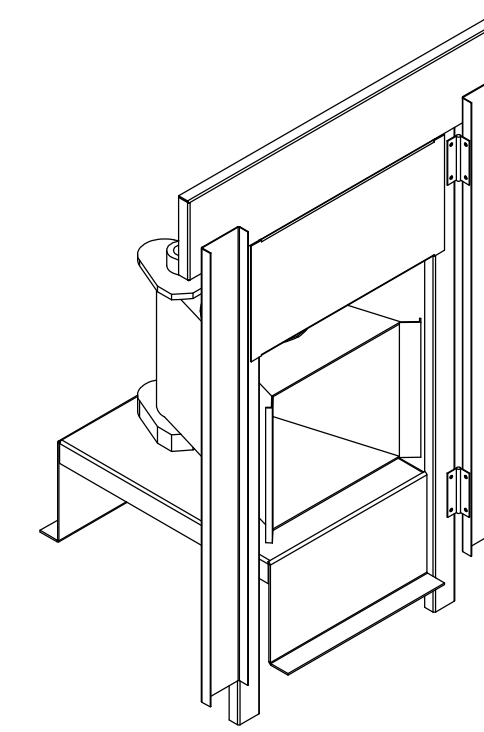

DIRECT FIRED (DF) PROFILE PLATE ASSEMBLY

DIRECT FIRED PROFILE PLATE SPECIFICATIONS:

DESCRIPTION:
 DIRECT FIRED BURNERS SHALL HAVE PATENTED (US PATENT NO. US6629523B2), SELF-ADJUSTING PROFILE PLATES DESIGNED TO ENSURE PROPER AIR VELOCITY AND PRESSURE DROP ACROSS THE BURNER. PROFILE PLATES SHALL ALLOW BURNERS TO ACHIEVE CLEAN COMBUSTION BY LIMITING BY-PRODUCT LEVELS TO A MAXIMUM OF 5PPM OF CARBON MONOXIDE (CO), AND 0.5PPM OF NITROGEN DIOXIDE (NO2). DIRECT FIRED UNITS SHALL BE CONFIGURED WITH THE BLOWER MOUNTED DOWNSTREAM OF THE BURNER. THIS ARRANGEMENT WILL ENSURE A CONSISTENT AIRFLOW, REGARDLESS OF INLET AIR TEMPERATURE.

APPLICATION:
 SPRING-LOADED BURNER PROFILE PLATES ARE ENGINEERED TO AUTOMATICALLY REACT TO THE MOMENTUM OF A FRESH AIR STREAM, WITHOUT THE NEED FOR ANY MOTORS OR ACTUATORS TO MECHANICALLY ADJUST THEM. WITH THIS FEATURE, ALL DF UNITS ARE DESIGNED FOR DEMAND CONTROL VENTILATION (DCV) REQUIREMENTS.

CERTIFICATIONS:
 ALL PROFILE PLATE ASSEMBLIES SHALL BE INCLUDED IN THE DF UNIT'S ETL LISTING AND COMPLY WITH COMBINED SAFETY STANDARDS ANSI Z83.4 AND CSA 3.7 (NON-RECIRCULATING DF HEATERS) AND ANSI Z83.18 (RECIRCULATING DF HEATERS).

GENERAL CONSTRUCTION:
 -PROFILE PLATES SHALL BE FORMED FROM G90 GALVANIZED STEEL.
 -PROFILE PLATES SHALL VARY IN SIZE PER UNIT.
 -PROFILE PLATES SHALL BE MOUNTED ALONG THE SAME PLANE AS THE DISCHARGE OF THE BURNER.
 -DESIGN SHALL INCORPORATE PROPERLY TORQUED, PERMANENTLY MOUNTED SPRING HINGES.
 -SPRING HINGES SHALL BE MADE FROM PLATED STEEL.

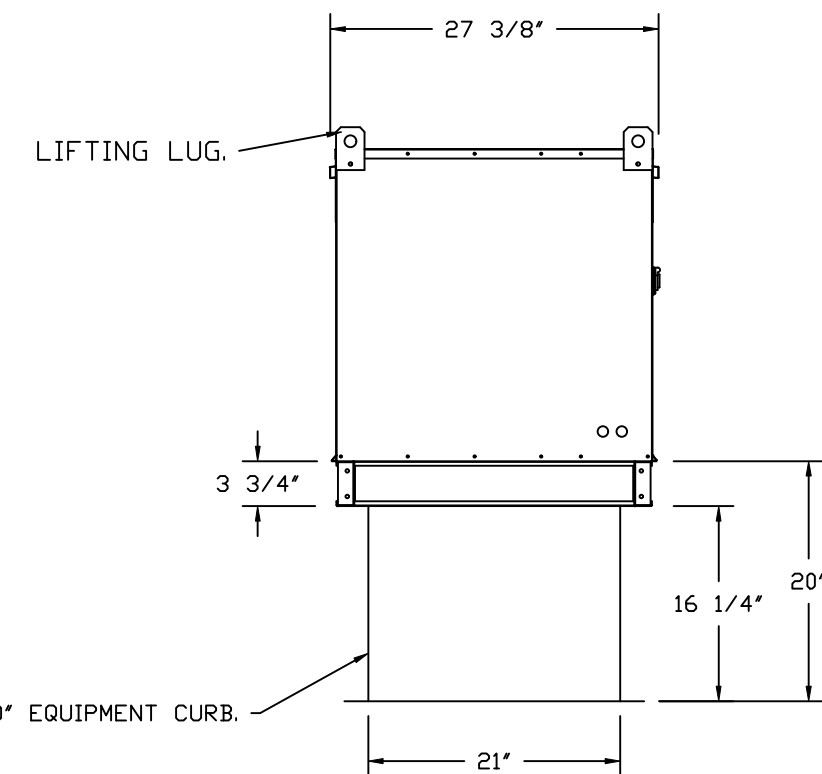
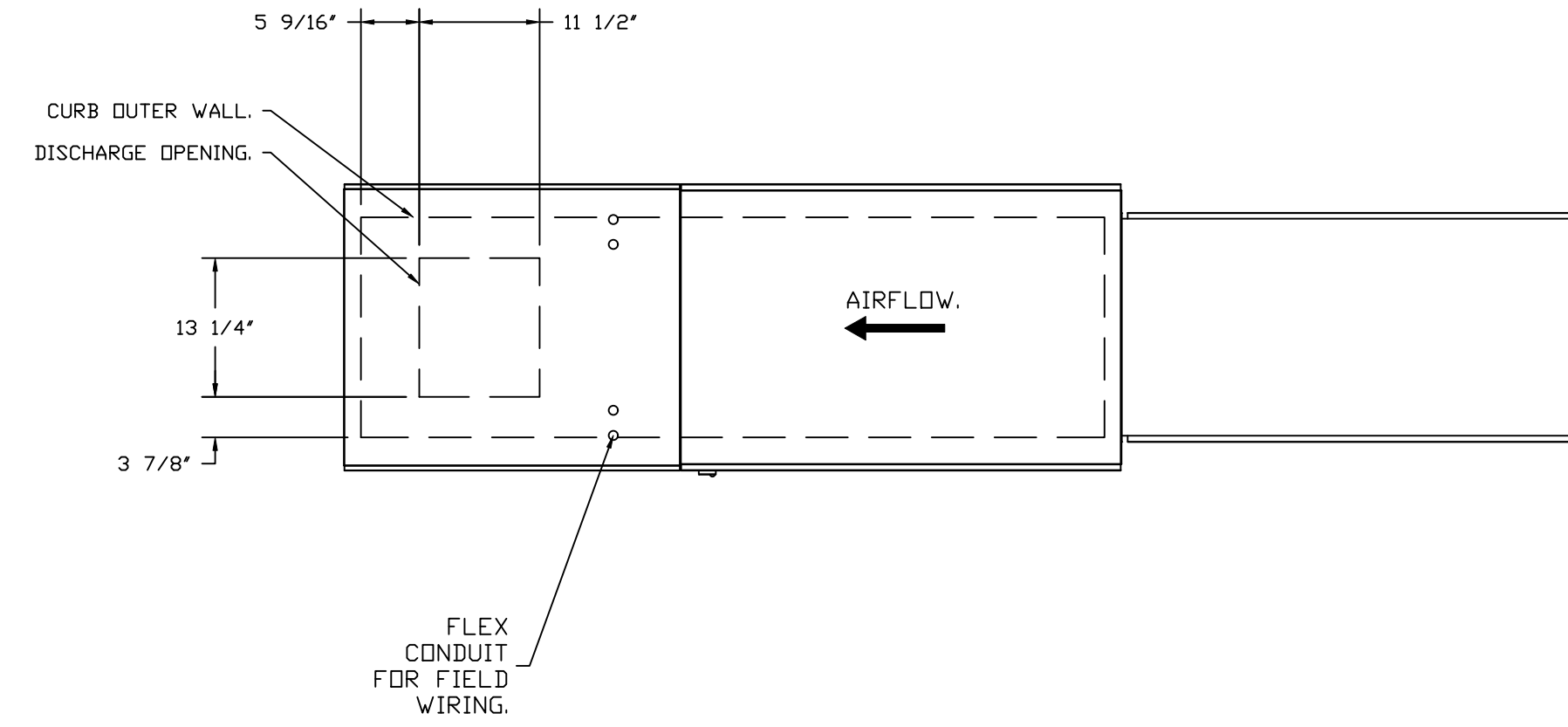

ROOF OPENING 2" SMALLER THAN CURB DIMENSION.

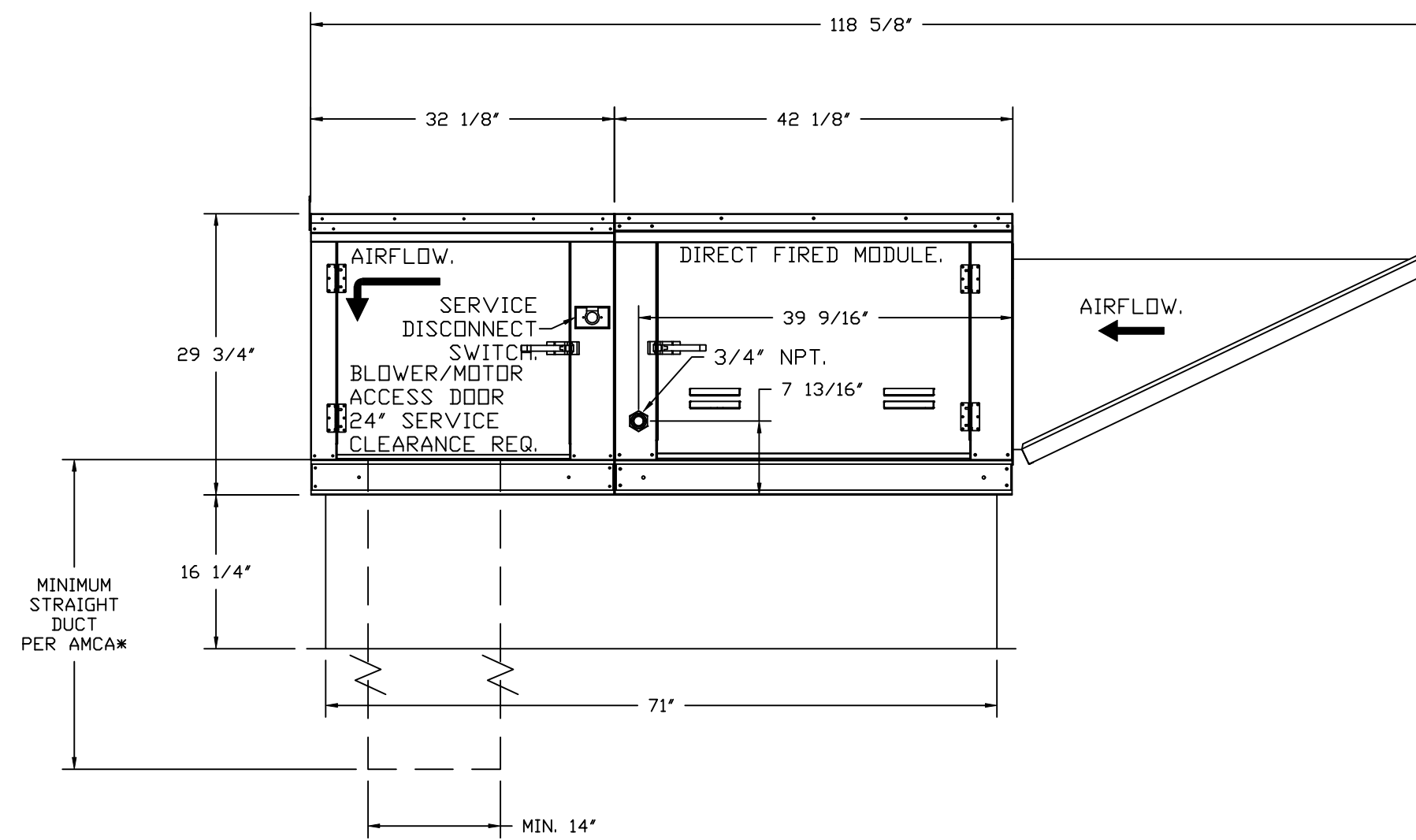

OPTIONS:
 - FULL BOTTOM CORNERS.

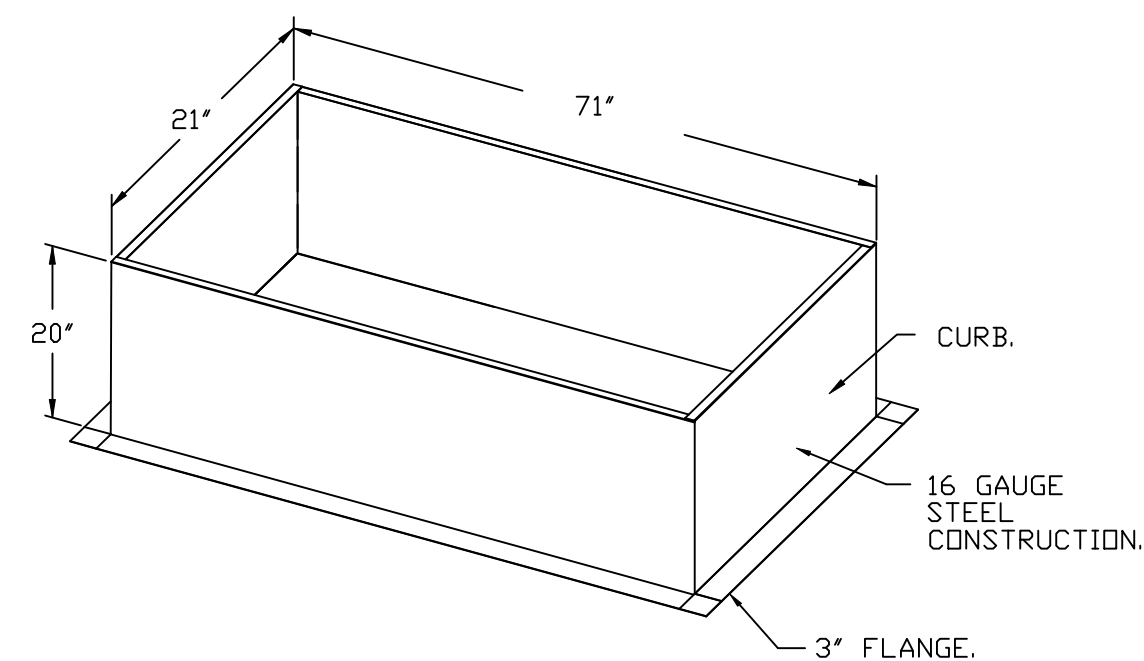

REVISIONS

| DESCRIPTION | DATE |
|-------------|------|
| | |
| | |
| | |
| | |

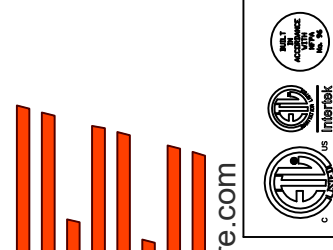

www.captiveaire.com
 www.captiveaire.com

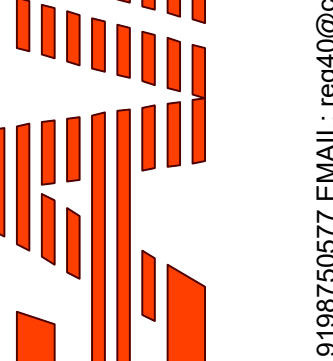

Highwoods Group

4641 Paragon Park Rd., Raleigh, NC 27616 PHONE: (919) 975 - 0420 FAX: 9198750577 EMAIL: reg40@captiveaire.com

CHIPOTLE EAST MELBOURNE #5337
 INDIAN HARBOR BEACH, FL, 32937

DATE: 9/10/2024

DWG.#:
 7032765

DRAWN BY: JMB-40

SCALE:
 3/4" = 1'-0"

MASTER DRAWING

SHEET NO.
 8

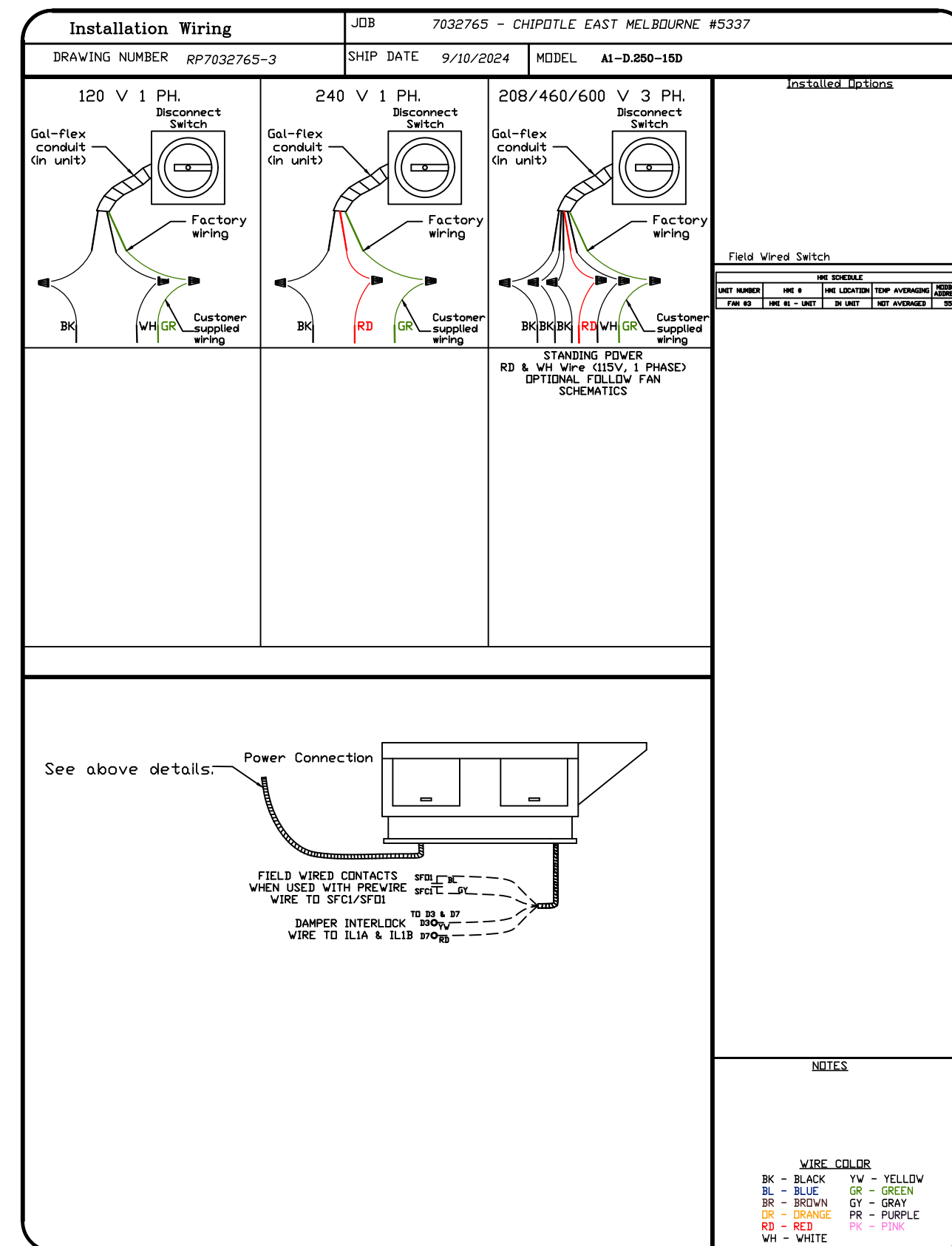
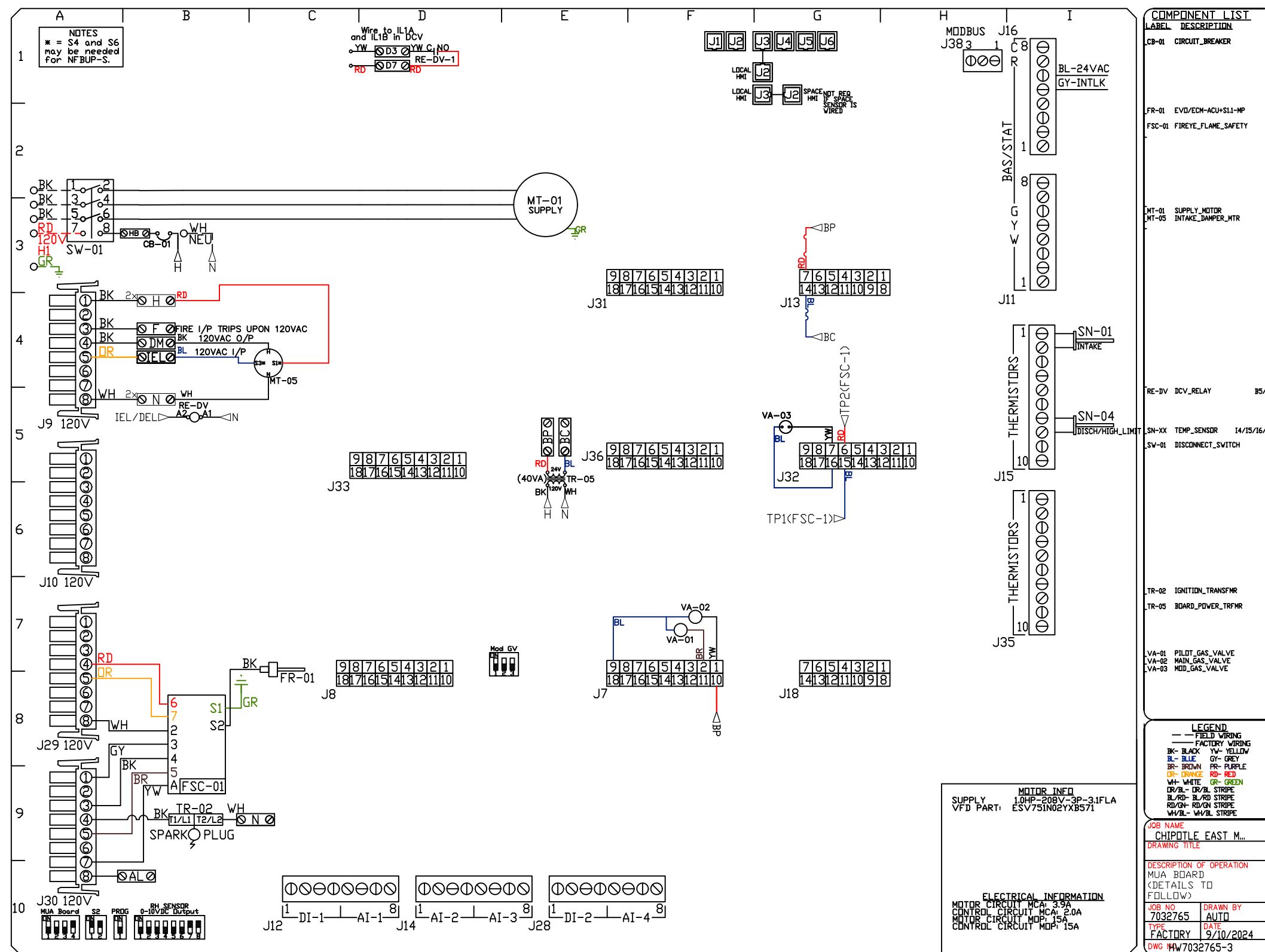
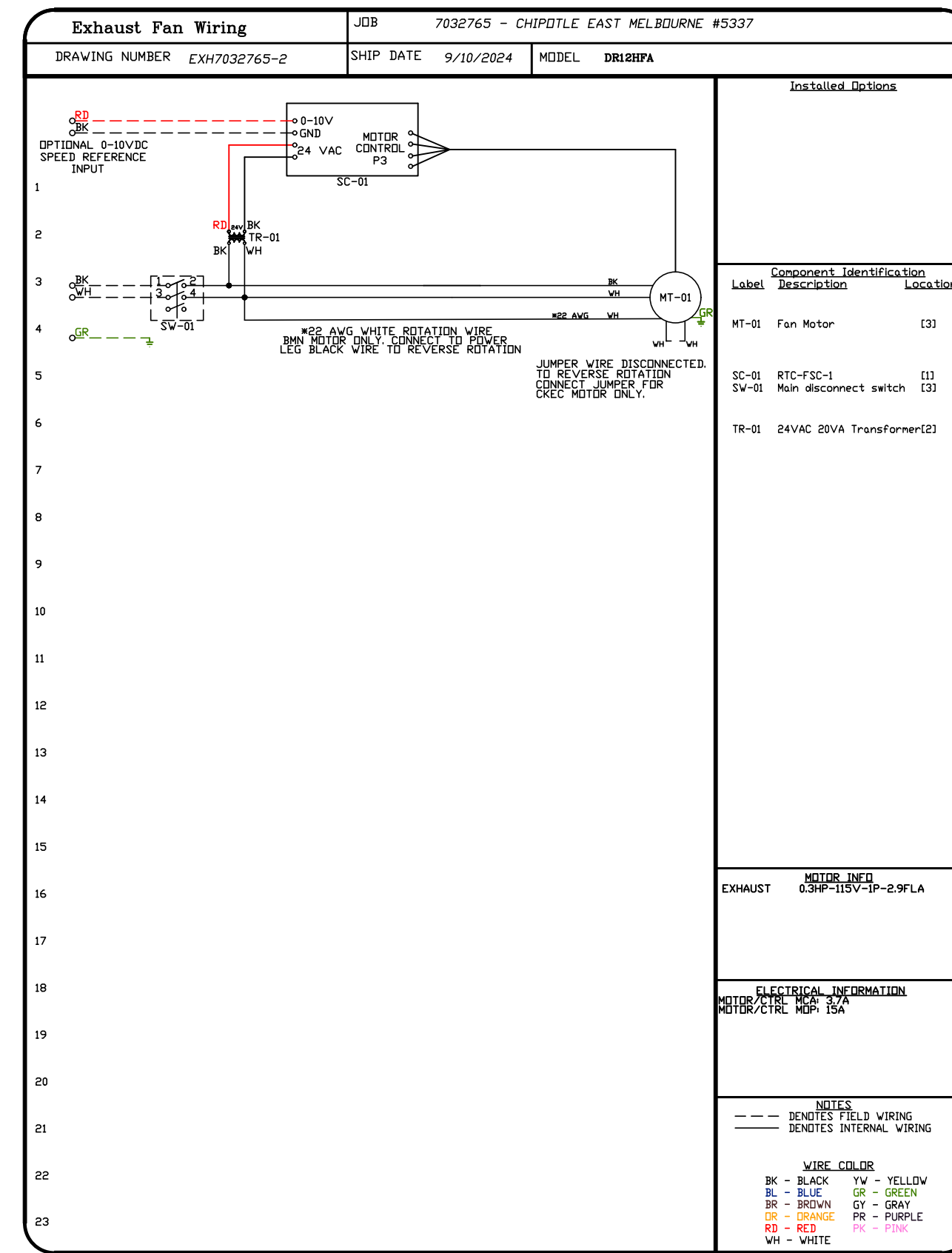
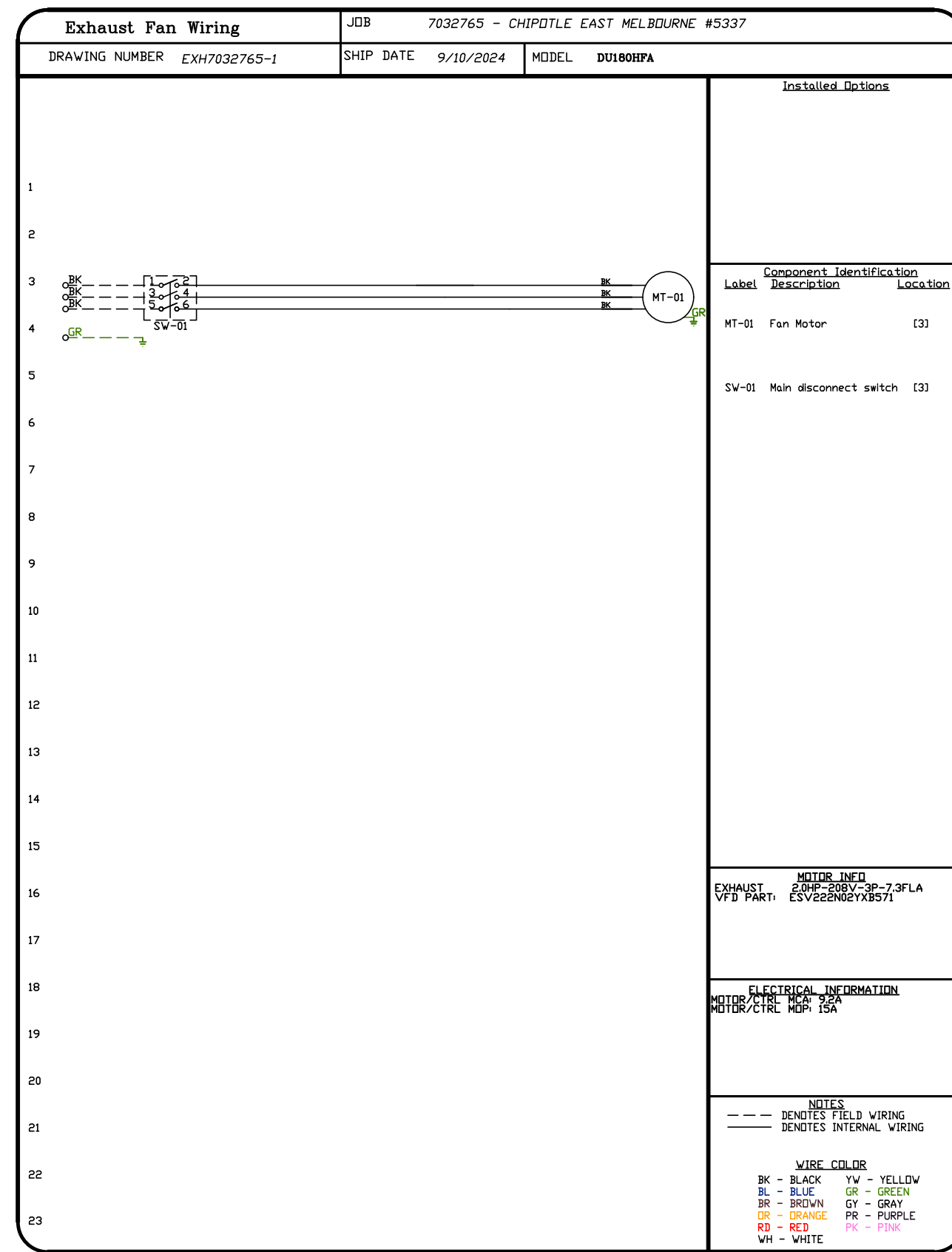

REVISIONS

| DESCRIPTION | DATE: |
|-------------|-------|
| | |
| | |
| | |
| | |
| | |

CHIPOTLE EAST MELBOURNE #5337
INDIAN HARBOR BEACH, FL, 32937

DATE: 9/10/2024
DWG.#: 7032765
DRAWN BY: JMB-40
SCALE: 3/4" = 1'-0"
MASTER DRAWING

SHEET NO.
9

CAPTIVE
 Highwoods Group
 www.captive.com
 4641 Paragon Park Rd., Raleigh, NC 27616 PHONE: (919) 575-0420 FAX: 9198750577 EMAIL: reg40@captive.com

