

Report By:

National TAB
1329 E. KEMPER ROAD
SUITE 4210
CINCINNATI, OH 45246



Report: TAB REPORT
Function: Test, Adjust, & Balance
Date: 03/07/2024

PROJECT

Altium Packaging - Cooling Water System (Lenexa, KS)

11725 W 85th Street

Overland Park, KS 66214

Client

Clark Nexsen
440 Martin Luther King Jr Blvd
Macon, GA 31201

National TAB

Project: Altium Packaging - Cooling Water System (Lenexa, KS)

Table Of Contents

Section	Page #
Pumps - Husky	3
Chiller - Husky	11
Water Tower - Husky	12
Process Flow Devices - Husky	14
Chilled Flow Devices - Husky	15
Bypass Valve - Husky	16
Pumps - Wheel	22
Chiller - Wheel	26
Water Towers - Wheel	27
Flow Devices - Wheel Process	29
Flow Devices - Wheel Chilled	30
Piping Plan	31



National TAB

Project: Altium Packaging - Cooling Water System (Lenexa, KS)

System/Unit: Pump

Asset: CTP-1

AREA:HUSY MECH RM

Unit Data		
	Design	Actual
MFG	EXISTING	PACO
Model Num	EXISTING	1050957-1400081882
Serial Num	-	674200352-10
Service	-	TOWER WATER
Type	-	CENTRIFUGAL
Configuration	-	HORIZONTAL
Pump RPM	-	1750
GPM/HD	1250-70	1250-70
Impeller Diameter	-	9.42

Motor Data		
	Design	Actual
Motor MFG	-	BALDOR
Frame	-	286JH
Horsepower	30	30
Motor Rpm	-	1775
Phase	-	3
Voltage	-	460
Amperage	-	36
Service Factor	-	1.15
Efficiency	-	94.1
Power Factor	-	82

Test Data		
	Design	Actual
Act Impeller Dia (IN)	-	9.42
Valve Open GPM (FT)	-	1350
Valve Open Diff (FT)	-	59.94
Final Suction Pres (FT)	-	3.16
Final Discharge Pres (FT)	-	80.5
Total Head Pres (FT)	70	77.4
Final GPM	1250	1191
Pump Rotation	-	CORRECT
Motor RPM	-	1775
Pump RPM	-	1775
Motor Frequency	-	60HZ
System SetPt	-	VALVE POSITION: 4
RL Voltage	-	472
RL Amperage	-	31 ANALOG GAUGE
Brake Horse Power	-	25.8

Completed By: Tyler Youells on 08/25/2023



National TAB

Project: Altium Packaging - Cooling Water System (Lenexa, KS)

System/Unit: Pump

Asset: CTP-2

AREA:HUSY MECH RM

Unit Data		
	Design	Actual
MFG	EXISTING	PACO
Model Num	EXISTING	1050957
Serial Num	-	203012
Service	-	TOWER WATER
Type	-	CENTRIFUGAL
Configuration	-	HORIZONTAL
Pump RPM	-	1750
GPM/HD	1250-70	1250-70
Impeller Diameter	-	9.45

Motor Data		
	Design	Actual
Motor MFG	-	WEG
Frame	-	286JH
Horsepower	30	30
Motor Rpm	-	1765
Phase	-	3
Voltage	-	460
Amperage	-	35.1
Service Factor	-	1.15
Efficiency	-	93.6
Power Factor	-	0.84

Test Data		
	Design	Actual
Act Impeller Dia (IN)	-	9.45
Valve Open GPM (FT)	-	1295
Valve Open Diff (FT)	-	65.2
Final Suction Pres (FT)	-	1.9
Final Discharge Pres (FT)	-	78.7
Total Head Pres (FT)	70	76.8
Final GPM	1250	1193
Pump Rotation	-	CORRECT
Motor RPM	-	1765
Pump RPM	-	1765
Motor Frequency	-	60HZ
System SetPt	-	VALVE POSITION: 5
RL Voltage	-	472
RL Amperage	-	29
Brake Horse Power	-	24.8

Completed By: Tyler Youells on 08/25/2023



National TAB

Project: Altium Packaging - Cooling Water System (Lenexa, KS)

System/Unit: Pump

Asset: CTP-3

AREA:HUSY MECH RM

Unit Data		
	Design	Actual
MFG	EXISTING	PACO
Model Num	EXISTING	1050957140001181
Serial Num	-	SP-E13413-0701
Service	-	TOWER WATER
Type	-	CENTRIFUGAL
Configuration	-	HORIZONTAL
Pump RPM	-	1750
GPM/HD	1250-70	1250-70
Impeller Diameter	-	9.6"

Motor Data		
	Design	Actual
Motor MFG	-	BALDOR
Frame	-	286JH
Horsepower	30	30
Motor Rpm	-	1760
Phase	-	3
Voltage	-	460
Amperage	-	36
Service Factor	-	1.15
Efficiency	-	92.4
Power Factor	-	84

Test Data		
	Design	Actual
Act Impeller Dia (IN)	-	9.6"
Valve Open GPM (FT)	-	1227
Valve Open Diff (FT)	-	72.6
Final Suction Pres (FT)	-	2.68
Final Discharge Pres (FT)	-	75.3
Total Head Pres (FT)	70	72.6
Final GPM	1250	1227
Pump Rotation	-	CORRECT
Motor RPM	-	1775
Pump RPM	-	1775
Motor Frequency	-	60HZ
System SetPt	-	VALVE POSITION: FULL OPEN
RL Voltage	-	472
RL Amperage	-	36
Brake Horse Power	-	30.0

Completed By: Tyler Youells on 08/25/2023



National TAB

Project: Altium Packaging - Cooling Water System (Lenexa, KS)

System/Unit: Pump

Asset: CWP-1

AREA:HUSY MECH RM

Unit Data		
	Design	Actual
MFG	EXISTING	PACO
Model Num	EXISTING	11-50157-158201
Serial Num	-	197100369210
Service	-	CHILLED WATER LOOP
Type	-	CENTRIFUGAL
Configuration	-	HORIZONTAL
Pump RPM	-	NL
GPM/HD	1350-200	1350-220
Impeller Diameter	-	15.00

Motor Data		
	Design	Actual
Motor MFG	-	BALDOR RELIANCE
Frame	-	405T
Horsepower	125	125
Motor Rpm	-	1775
Phase	-	3
Voltage	-	460
Amperage	-	143
Service Factor	-	1.15
Efficiency	-	95.4%
Power Factor	-	86%

Test Data		
	Design	Actual
Act Impeller Dia (IN)	-	14.88
Valve Open GPM (FT)	-	1393
Valve Open Diff (FT)	-	206.5
Final Suction Pres (FT)	-	25.63
Final Discharge Pres (FT)	-	232.1
Total Head Pres (FT)	-	206.5
Final GPM	-	1393
Pump Rotation	-	CORRECT
Motor RPM	-	1775
Pump RPM	-	1775
Motor Frequency	-	60HZ
System SetPt	-	FULL OPEN
RL Voltage	-	473
RL Amperage	-	124
Brake Horse Power	-	107.5

Completed By: Tyler Youells on 09/18/2023



National TAB

Project: Altium Packaging - Cooling Water System (Lenexa, KS)

System/Unit: Pump

Asset: CWP-2

AREA:HUSY MECH RM

Unit Data		
	Design	Actual
MFG	EXISTING	PACO
Model Num	EXISTING	11-50157-158201
Serial Num	-	197101766010
Service	-	CHILLED WATER
Type	-	CENTRIFUGAL
Configuration	-	HORIZONTAL
Pump RPM	-	1775
GPM/HD	1350-200	1500-210
Impeller Diameter	-	15.00

Motor Data		
	Design	Actual
Motor MFG	-	BALDOR
Frame	-	405T
Horsepower	125	125
Motor Rpm	-	1775
Phase	-	3
Voltage	-	460
Amperage	-	145
Service Factor	-	1.15
Efficiency	-	94.5%
Power Factor	-	85%

Test Data		
	Design	Actual
Pump Off Pres	-	-
Pump Dead Head Pres	-	-
Act Impeller Dia (IN)	-	-
Valve Open GPM (FT)	-	-
Valve Open Diff (FT)	-	-
Final Suction Pres (FT)	-	-
Final Discharge Pres (FT)	-	-
Total Head Pres (FT)	-	-
Final GPM	-	-
Pump Rotation	-	-
Motor RPM	-	-
Pump RPM	-	-
Motor Frequency	-	-
System SetPt	-	-
RL Voltage	-	-
RL Amperage	-	-
Brake Horse Power	-	-

Completed By: Tyler Youells on 09/18/2023

Notes:

Pump/Motor is locked out and does not run. unable to perform TAB and verify flow.

Written By: Tyler Youells on 09/18/2023



National TAB

Project: Altium Packaging - Cooling Water System (Lenexa, KS)

System/Unit: Pump

Asset: CWP-3

AREA:HUSY MECH RM

Unit Data		
	Design	Actual
MFG	EXISTING	PACO
Model Num	EXISTING	11-50157-158201
Serial Num	-	1971089264-10
Service	-	CHILLED WATER LOOP
Type	-	CENTRIFUGAL
Configuration	-	HORIZONTAL
Pump RPM	-	NL
GPM/HD	1350-200	1350-220
Impeller Diameter	-	14.88

Motor Data		
	Design	Actual
Motor MFG	-	BALDOR RELIANCE
Frame	-	405T
Horsepower	125	125
Motor Rpm	-	1775
Phase	-	3
Voltage	-	460
Amperage	-	143
Service Factor	-	1.15
Efficiency	-	95.4%
Power Factor	-	86%

Test Data		
	Design	Actual
Act Impeller Dia (IN)	-	14.88
Valve Open GPM (FT)	-	1412
Valve Open Diff (FT)	-	201
Final Suction Pres (FT)	-	25.8
Final Discharge Pres (FT)	-	227
Total Head Pres (FT)	-	201
Final GPM	-	1412
Pump Rotation	-	CORRECT
Motor RPM	-	1775
Pump RPM	-	1775
Motor Frequency	-	60HZ
System SetPt	-	FULL OPEN
RL Voltage	-	473
RL Amperage	-	125 ANALOG
Brake Horse Power	-	109.2

Completed By: Tyler Youells on 09/18/2023



National TAB

Project: Altium Packaging - Cooling Water System (Lenexa, KS)

System/Unit: Pump

Asset: PC-1

AREA:HUSY MECH RM

Unit Data		
	Design	Actual
MFG	EXISTING	PACO
Model Num	EXISTING	1040959-1A000
Serial Num	-	NL
Service	-	PROCESS WATER
Type	-	CENTRIFUGAL
Configuration	-	HORIZONTAL
Pump RPM	-	3500
GPM/HD	1000-175	1000-175
Impeller Diameter	-	NL

Motor Data		
	Design	Actual
Motor MFG	-	WEG
Frame	-	324/6JM
Horsepower	60	60
Motor Rpm	-	3560
Phase	-	3
Voltage	-	460
Amperage	-	71
Service Factor	-	1.25
Efficiency	-	93.6
Power Factor	-	0.85

Test Data		
	Design	Actual
Valve Open GPM (FT)	-	1217
Valve Open Diff (FT)	-	118
Final Suction Pres (FT)	-	35.5
Final Discharge Pres (FT)	-	195
Total Head Pres (FT)	-	160
Final GPM	-	1045
Pump Rotation	-	CORRECT
Motor RPM	-	3650
Pump RPM	-	3650
Motor Frequency	-	60HZ
System SetPt	-	VALVE POSTION: 3
RL Voltage	-	472
RL Amperage	-	67 (ANALOG)
Brake Horse Power	-	56.6

Completed By: Tyler Youells on 08/25/2023



National TAB

Project: Altium Packaging - Cooling Water System (Lenexa, KS)

System/Unit: Pump

Asset: PC-2

AREA:HUSY MECH RM

Unit Data		
	Design	Actual
MFG	EXISTING	PACO
Model Num	EXISTING	10-40959-1A0001-1911
Serial Num	-	148288
Service	-	PROCESS WATER
Type	-	CENTRIFUGAL
Configuration	-	HORIZONTAL
Pump RPM	-	3500
GPM/HD	1110-160	1110-160
Impeller Diameter	-	NL

Motor Data		
	Design	Actual
Motor MFG	-	WEG
Frame	-	326JM
Horsepower	60	60
Motor Rpm	-	3555
Phase	-	3
Voltage	-	460
Amperage	-	70.6
Service Factor	-	1.15
Efficiency	-	93
Power Factor	-	0.86

Test Data		
	Design	Actual
Valve Open GPM (FT)	-	1154
Valve Open Diff (FT)	-	148
Final Suction Pres (FT)	-	42
Final Discharge Pres (FT)	-	211.5
Total Head Pres (FT)	-	169.9
Final GPM	-	1077
Pump Rotation	-	CORRECT
Motor RPM	-	3555
Pump RPM	-	3555
Motor Frequency	-	60HZ
System SetPt	-	VALVE POSITION: 4
RL Voltage	-	472
RL Amperage	-	70 (ANALOG)
Brake Horse Power	-	59.4

Completed By: Tyler Youells on 08/25/2023



National TAB

Project: Altium Packaging - Cooling Water System (Lenexa, KS)

System/Unit: Chiller

Asset: C-2

AREA:

Unit Data		
	Design	Actual
MFG	na	YORK
Model Num	na	YSDCCBS2-CJES
Serial Num	-	SHKM-483390
Type	-	WATER COOLED
Service	-	PROCESS/TOWER LOOP

Test Data-Evaporator		
	Design	Actual
GPM	1350	1412
Balance Valve Setting	-	FULL OPEN
EWT (F)	46.4	50
LWT (F)	42	48
Water Temp Delta T (F)	-	2
CHW Delta P	16.1 FT	17.6FT

Test Data-Condenser		
	Design	Actual
CW GPM	750	801
Balance Valve Setting	-	4
EWT (F)	85	76
LWT (F)	95	80
Water Temp Delta T (F)	-	4
CHW Delta P	10.1 FT	11.5FT

Completed By: Tyler Youells on 09/18/2023



National TAB

Project: Altium Packaging - Cooling Water System (Lenexa, KS)

System/Unit: Water Tower

Asset: CT-1

AREA:OUTDOOR HUSKY MECH RM

Unit Data		
	Design	Actual
MFG	EXISTING	MARLEY SPX
Model Num	EXISTING	10155187 B1NC8407QAN1BGF

Test Data		
	Design	Actual
CW GPM	1250	1192
EWT (F)	95.0	NO LOAD
LWT (F)	85.0	NO LOAD

Completed By: Tyler Youells on 08/25/2023



National TAB

Project: Altium Packaging - Cooling Water System (Lenexa, KS)

System/Unit: Water Tower

Asset: CT-2

AREA:OUTDOOR HUSKY MECH RM

Unit Data		
	Design	Actual
MFG	EXISTING	MARLEY SPX
Model Num	EXISTING	10155187 A1NC8407QAN1BGF

Test Data		
	Design	Actual
CW GPM	1250	1192
EWT (F)	95.0	NO LOAD
LWT (F)	85.0	NO LOAD

Completed By: Tyler Youells on 08/25/2023



National TAB

Project: Altium Packaging - Cooling Water System (Lenexa, KS)

Circuit Setter

HUSKY PROCESS FLOW DEVICES/

Asset											
Asset Name	Size	Type	Design Service	Service	Design GPM	Setting	Low Pres	High Pres	Delta P	Final GPM	% to Design
VALVE1	NA	BUTTERFLY	LINE 21	LINE 21	82	FULL OPEN	19	52	33 PSI	86	104.9
VALVE2	NA	NA	LINE 24	LINE 24	100	FULL OPEN	18.13	50.36	32.32 PSI	103.8	103.8
VALVE3	3"	MANUAL	LINE 21	LINE 21	82	2.5	NA	NA	26.75 PSI	82.7	100.9
VALVE4	3"	MANUAL	LINE 24	LINE 24	100	3	NA	NA	27.06 PSI	100.5	100.5
VALVE5	NA	NA	LINE 22	LINE 22	111	FULL OPEN	18.5	52	32.8 PSI	116	104.5
VALVE6			LINE 25	LINE 25	50	FULL OPEN	18.18	50.9	32.75 PSI	52.2	104.4
VALVE7	3"	MANUAL	LINE 22	LINE 22	111	3.2	NA	NA	28.2 PSI	115	103.6
VALVE8	2"	MANUAL	LINE 25	LINE 25	50	3	NA	NA	2.98 PSI	49.5	99.0
VALVE9	NA	NA	LINE 23	LINE 23	40	FULL OPEN	16.6	49.6	33.06 PSI	42	105.0
VALVE10			LINE 26	LINE 26	61	NA	NA	NA	NA		-
VALVE11	2"	MANUAL	LINE 23	LINE 23	40	2.5	NA	NA	2.587 PSI	39.8	99.5
VALVE12	3"	MANUAL	LINE 26	LINE 26	61	NA	NA	NA	NA		-
VALVE13	3"	MANUAL									
Total					888					787.5	88.68%



National TAB

Project: Altium Packaging - Cooling Water System (Lenexa, KS)

Circuit Setter

HUSKY CHILLED FLOW DEVICES/

Asset								
Asset Name	Size	Type	Service	Design GPM	Setting	Delta P	Final GPM	% to Design
CS1	3"	MANUAL	AHU-1	95	50	128FT	99	104.2
CS2	4"	MANUAL	LINE 21	251	2.8	60 PSI	265	105.6
CS3	3"	MANUAL	LINE 22	145	3.5	40.9 PSI	162	111.7
CS4	2.5"	MANUAL	LINE 23	71	1.2	56PSI	75	105.6
CS5	4"	MANUAL	LINE 24	290	2.8	69 PSI	285	98.3
CS6	4"	MANUAL	LINE 25	255	5	3.7 PSI	238	93.3
CS7	NA	NA	LINE 26	180	NA	NA	0	0.0
CS8	2"	MANUAL	AHU-2	34.7	3.5	1.7 PSI	32.9	94.8
CS9	4"	MANUAL	MAIN HEADER BYPASS	28.3	4	68 PSI	281	992.9
Total				1350			1437.9	106.51%

Asset	Notes	Date	Written By
CS9	BYPASS FLOW INCREASED DUE TO LINE 26 NOTE EXISTING	10/02/2023	Tyler Youells



National TAB

Project: Altium Packaging - Cooling Water System (Lenexa, KS)

System/Unit: Bypass Valve

Asset: LINE21

AREA:HUSKY CHILLED

Unit Data

	Design	Actual
MFG	NA	NA
Model Num	NA	NA
Type	-	MANUAL
Service	-	LINE 21

Test Data

	Design	Actual
GPM	251	250.8
Setting	-	OPEN
Low Pres	-	15 PSI
High Pres	-	74.6 PSI
SetPt Delta P	-	60 PSI
% to Design	-	



National TAB

Project: Altium Packaging - Cooling Water System (Lenexa, KS)

System/Unit: Bypass Valve

Asset: LINE22

AREA:HUSKY CHILLED

Unit Data		
	Design	Actual
MFG	NA	NA
Model Num	NA	NA
Type	-	MANUAL
Service	-	LINE 22

Test Data		
	Design	Actual
GPM	145	155.7
Setting	-	4
Low Pres	-	16.8 PSI
High Pres	-	86.1 PSI
SetPt Delta P	-	60 PSI
% to Design	-	



National TAB

Project: Altium Packaging - Cooling Water System (Lenexa, KS)

System/Unit: Bypass Valve

Asset: LINE23

AREA:HUSKY CHILLED

Unit Data		
	Design	Actual
MFG	NA	NA
Model Num	NA	NA
Type	-	MANUAL
Service	-	LINE 23

Test Data		
	Design	Actual
GPM	71	71.7
Setting	-	OPEN
Low Pres	-	14 PSI
High Pres	-	75.2 PSI
SetPt Delta P	-	60 PSI
% to Design	-	



National TAB

Project: Altium Packaging - Cooling Water System (Lenexa, KS)

System/Unit: Bypass Valve

Asset: LINE24

AREA:HUSKY CHILLED

Unit Data		
	Design	Actual
MFG	NA	NA
Model Num	NA	NA
Type	-	MANUAL
Service	-	LINE 24

Test Data		
	Design	Actual
GPM	290	296.2
Setting	-	OPEN
Low Pres	-	15.9 PSI
High Pres	-	72.3 PSI
SetPt Delta P	-	55 PSI
% to Design	-	



National TAB

Project: Altium Packaging - Cooling Water System (Lenexa, KS)

System/Unit: Bypass Valve

Asset: LINE25

AREA:HUSKY CHILLED

Unit Data		
	Design	Actual
MFG	NA	NA
Model Num	NA	NA
Type	-	MANUAL
Service	-	LINE 25

Test Data		
	Design	Actual
GPM	255	259.6
Setting	-	3
Low Pres	-	26.1 PSI
High Pres	-	83.3 PSI
SetPt Delta P	-	55 PSI
% to Design	-	



National TAB

Project: Altium Packaging - Cooling Water System (Lenexa, KS)

System/Unit: Bypass Valve

Asset: LINE26

AREA:HUSKY CHILLED

Unit Data		
	Design	Actual
MFG	NA	NA
Model Num	NA	NA
Type	-	MANUAL
Service	-	LINE 26

Test Data		
	Design	Actual
GPM	180	0
Setting	-	NA
Low Pres	-	NA
High Pres	-	NA
SetPt Delta P	-	NA
% to Design	-	



National TAB

Project: Altium Packaging - Cooling Water System (Lenexa, KS)

System/Unit: Pump

Asset: P-1

AREA:WHEEL MECH RM

Unit Data		
	Design	Actual
MFG	B&G	B&G
Model Num	4BD	2.5BB
Serial Num	-	C349466-01
Service	-	CHILLED WATER
Type	-	CENTRIFUGAL
Configuration	-	END SUCTION
Pump RPM	-	3600
GPM/HD	500/180	500-180
Impeller Diameter	7.5	7.5

Motor Data		
	Design	Actual
Motor MFG	-	BALDOR RELIANCE
Frame	-	286JM
Horsepower	40	40
Motor Rpm	-	3510
Phase	-	3
Voltage	-	460
Amperage	-	45
Service Factor	-	1.15
Efficiency	-	92.4
Power Factor	-	0.90

Test Data		
	Design	Actual
Act Impeller Dia (IN)	-	7.5
Valve Open GPM (FT)	-	504
Valve Open Diff (FT)	-	177.4
Final Suction Pres (FT)	-	25.9 PSI
Final Discharge Pres (FT)	-	109.5 PSI
Total Head Pres (FT)	-	193 FT
Final GPM	-	483
Pump Rotation	-	CORRECT
Motor RPM	-	3550
Pump RPM	-	3550
Motor Frequency	-	@60 HZ
System SetPt	-	64.4 PSI DP
RL Voltage	-	459.9 V
RL Amperage	-	37.6 A

Completed By: Tyler Youells on 11/14/2023



National TAB

Project: Altium Packaging - Cooling Water System (Lenexa, KS)

System/Unit: Pump

Asset: P-2

AREA:WHEEL MECH RM

Unit Data		
	Design	Actual
MFG	B&G	B&G
Model Num	4BD	2.5BB
Serial Num	-	C349466-02
Service	-	CHILLED WATER
Type	-	CENTRIFUGAL
Configuration	-	END SUCTION
Pump RPM	-	3600
GPM/HD	500/180	500-180
Impeller Diameter	7.5	7.5

Motor Data		
	Design	Actual
Motor MFG	-	BALDOR RELIANCE
Frame	-	286JM
Horsepower	40	40
Motor Rpm	-	3510
Phase	-	3
Voltage	-	460
Amperage	-	45
Service Factor	-	1.15
Efficiency	-	92.4
Power Factor	-	0.90

Test Data		
	Design	Actual
Act Impeller Dia (IN)	-	7.5
Valve Open GPM (FT)	-	482
Valve Open Diff (FT)	-	193.8 FT
Final Suction Pres (FT)	-	26.8 PSI
Final Discharge Pres (FT)	-	110.8 PSI
Total Head Pres (FT)	-	193.8 FT
Final GPM	-	482
Pump Rotation	-	CORRECT
Motor RPM	-	3510
Pump RPM	-	3510
Motor Frequency	-	@60HZ
System SetPt	-	64.4 PSI DP
RL Voltage	-	459.9 V
RL Amperage	-	38 A

Completed By: Tyler Youells on 11/14/2023



National TAB

Project: Altium Packaging - Cooling Water System (Lenexa, KS)

System/Unit: Pump

Asset: P-3

AREA:WHEEL MECH RM

Unit Data		
	Design	Actual
MFG	B&G	B&G
Model Num	4BD	4BD
Serial Num	-	NL
Service	-	PROCESS WATER
Type	-	CENTRIFUGAL
Configuration	-	END SUCTION
Pump RPM	-	3550
GPM/HD	1250/162	1250/162
Impeller Diameter	7.75	7.75

Motor Data		
	Design	Actual
Motor MFG	-	WEG
Frame	-	364/5TS
Horsepower	75	75
Motor Rpm	-	3555
Phase	-	3
Voltage	-	460
Amperage	-	84.8
Service Factor	-	1.25
Efficiency	-	93.6
Power Factor	-	0.87

Test Data		
	Design	Actual
Act Impeller Dia (IN)	-	7.75
Valve Open GPM (FT)	-	1438
Valve Open Diff (FT)	-	127 FT
Final Suction Pres (FT)	-	0.97 PSI
Final Discharge Pres (FT)	-	68.9 PSI
Total Head Pres (FT)	168	157
Final GPM	-	1293
Pump Rotation	-	CORRECT
Motor RPM	-	3550
Pump RPM	-	3550
Motor Frequency	-	60HZ
System SetPt	-	15% TRIPLE DUTY
RL Voltage	-	469V
RL Amperage	-	72.1A

Completed By: Tyler Youells on 11/14/2023



National TAB

Project: Altium Packaging - Cooling Water System (Lenexa, KS)

System/Unit: Pump

Asset: P-4

AREA:WHEEL MECH RM

Unit Data		
	Design	Actual
MFG	B&G	B&G
Model Num	4BD	4BD
Serial Num	-	NL
Service	-	PROCESS
Type	-	CENTRIFUGAL
Configuration	-	END SUCTION
Pump RPM	-	3550
GPM/HD	-	1250162
Impeller Diameter	-	7.75

Motor Data		
	Design	Actual
Motor MFG	-	WEG
Frame	-	364/5TS
Horsepower	-	75
Motor Rpm	-	3550
Phase	-	3
Voltage	-	460
Amperage	-	84.8
Service Factor	-	1.25
Efficiency	-	93.6
Power Factor	-	0.87

Test Data		
	Design	Actual
Act Impeller Dia (IN)	-	7.75
Valve Open GPM (FT)	-	1544
Valve Open Diff (FT)	-	110.1
Final Suction Pres (FT)	-	0.973PSI
Final Discharge Pres (FT)	-	68.93 PSI
Total Head Pres (FT)	-	156.8
Final GPM	-	1294
Pump Rotation	-	CORRECT
Motor RPM	-	3550
Pump RPM	-	3550
Motor Frequency	-	60HZ
System SetPt	-	15% TRIPLE DUTY
RL Voltage	-	470V
RL Amperage	-	70.3A

Completed By: Tyler Youells on 11/14/2023



National TAB

Project: Altium Packaging - Cooling Water System (Lenexa, KS)

System/Unit: Chiller

Asset: CHLR1

AREA:WHEEL ROOM

Unit Data		
	Design	Actual
MFG	TRANE	TRANE
Model Num	RTWD 160F 2L02 A1A1 AA2A 1A1Y 1B0A 0000 1000 000A	RTWD 160F 2L02 A1A1 AA2A 1A1Y 1B0A 0000 1000 000A
Serial Num	-	U20B06007
Type	-	WATER COOLED
Service	-	WHEEL LINE

Test Data-Evaporator		
	Design	Actual
GPM	-	483
Balance Valve Setting	-	N/A
EWT (F)	-	49
LWT (F)	-	42
Water Temp Delta T (F)	-	7 DEG
ENT Water Pres	-	109.1 PSI
LVG Water Pres	-	97.79 PSI
CHW Delta P	-	26.08FT

Test Data-Condenser		
	Design	Actual
CW GPM	480	477
Balance Valve Setting	-	8.0
EWT (F)	-	78
LWT (F)	-	80
Water Temp Delta T (F)	-	2
ENT Water Pres	-	21.92 PSI
LVG Water Pres	-	12.09 PSI
CHW Delta P	20.7FT	22.8 FT

Completed By: Tyler Youells on 01/03/2024

Notes:
CONDENSOR FLOW BALANCED USING GATE VALVE, BALANCE VALVE WAS DAMAGED (BALANCED VALVE WAS REPLACED PRIOR TO LEAVING AND VALVE WAS BALANCED)

Written By: Tyler Youells on 01/03/2024



National TAB

Project: Altium Packaging - Cooling Water System (Lenexa, KS)

System/Unit: Water Tower

Asset: CT-1

AREA:OUTDOOR WHEEL MECH RM

Unit Data		
	Design	Actual
MFG	EXISTING	MARLEY
Model Num	EXISTING	NC8405QAN1BGF
Serial Num	-	10155180-A1

Test Data		
	Design	Actual
CW GPM	1250	1293
EWT (F)	95.0	NO ACCESS
LWT (F)	85.0	NO ACCESS
Tower Water Pres Delta P	-	NO ACCESS

Completed By: Tyler Youells on 11/14/2023



National TAB

Project: Altium Packaging - Cooling Water System (Lenexa, KS)

System/Unit: Water Tower

Asset: CT-2

AREA:OUTDOOR WHEEL MECH RM

Unit Data		
	Design	Actual
MFG	EXISTING	MARLEY
Model Num	EXISTING	P15HG-1
Serial Num	-	247441

Test Data		
	Design	Actual
CW GPM	918	0
EWT (F)	95.0	0
LWT (F)	85.0	0
Tower Water Pres Delta P	-	0

Completed By: Tyler Youells on 11/14/2023

Notes:
COOLING TOWER NOT IN USE

Written By: Tyler Youells on 11/14/2023



National TAB

Project: Altium Packaging - Cooling Water System (Lenexa, KS)

Circuit Setter

WHEEL PROCESS FLOW DEVICES/

Asset									
Asset Name	Size	Type	Service	Design GPM	Cv	Setting	Delta P	Final GPM	% to Design
CS1	2"	MANUAL	LINE 1 BYPASS	36	63.67	2.5	0.35 PSI	38	105.6
CS2	2"	MANUAL	LINE 2 BYPASS	36	63.67	2.4	0.32PSI	36	100.0
CS3	NA	NA	NA	36	NA	0	0	0	0.0
CS4	2"	MANUAL	LINE 4 BYPASS	36	63.67	3.0	0.32 PSI	36	100.0
CS5	2"	MANUAL	LINE 5 BYPASS	36	63.67	2.4	0.308 PSI	35.3	98.1
CS6	2"	MANUAL	LINE 6 BYPASS	36	63.67	2.6	0.31 PSI	35.4	98.3
CS7	2"	MANUAL	LINE 7 BYPASS	36	63.67	2.5	0.35	38	105.6
CS8	2"	MANUAL	LINE 8 BYPASS	36	63.67	2.6	0.34 PSI	37	102.8
CS9	2"	MANUAL	LINE 9 BYPASS	36	63.67	2.5	0.33PSI	36.6	101.7
CS10	2"	MANUAL	LINE 10 BYPASS	36	63.67	2.6	0.32 PSI	36	100.0
CS11	2"	MANUAL	LINE 11 BYPASS	36	63.67	2.7	0.35 PSI	38	105.6
CS12	6"	MANUAL	HEADER BYPASS (LINE 1)	100	26.98	1.7	7.65PSI	74.6	74.6
CS13	6"	MANUAL	HEADER BYPASS (LINE 12)	238	82.03	2.8	5.71 PSI	196	82.4
CS14	2"	MANUAL	LAIKOS FILTER	85	63.67	4.0	2.08PSI	92	108.2
CS15	6"	MANUAL	CHILLER	480	NA	8.0	1.22 PSI	477	99.4
Total				1299				1205.9	92.83%



National TAB

Project: Altium Packaging - Cooling Water System (Lenexa, KS)

Circuit Setter

WHEEL CHILLED FLOW DEVICES/

Asset									
Asset Name	Size	Type	Service	Design GPM	Cv	Setting	Delta P	Final GPM	% to Design
CS1	3/4"	MANUAL	LINE 1 BYPASS	2	6.16	0.1	0.218 PSI	2.87	145.0
CS2	3/4"	MANUAL	LINE 2 BYPASS	2	6.16	0.1	0.233 PSI	2.97	150.0
CS3	NA	MANUAL	LINE 3 BYPASS	2	6.16	NA	NA	0	0.0
CS4	3/4"	MANUAL	LINE 4 BYPASS	2	6.16	0.1	0.262 PSI	3.15	160.0
CS5	3/4"	MANUAL	LINE 5 BYPASS	2	6.16	0.1	0.251 PSI	3.08	155.0
CS6	3/4"	MANUAL	LINE 6 BYPASS	2	6.16	0.1	0.257 PSI	3.12	155.0
CS7	3/4"	MANUAL	LINE 7 BYPASS	2	6.16	0.1	0.241 PSI	3.02	150.0
CS8	3/4"	MANUAL	LINE 8 BYPASS	2	6.16	0.1	0.250 PSI	3.08	155.0
CS9	3/4"	MANUAL	LINE 9 BYPASS	2	6.16	0.1	0.239 PSI	3.01	150.0
CS10	3/4"	MANUAL	LINE 10 BYPASS	2	6.16	0.1	0.252 PSI	3.09	155.0
CS11	3/4"	MANUAL	LINE 11 BYPASS	2	6.16	0.1	0.282 PSI	3.27	165.0
Total				22				30.659999999999997	139.36%

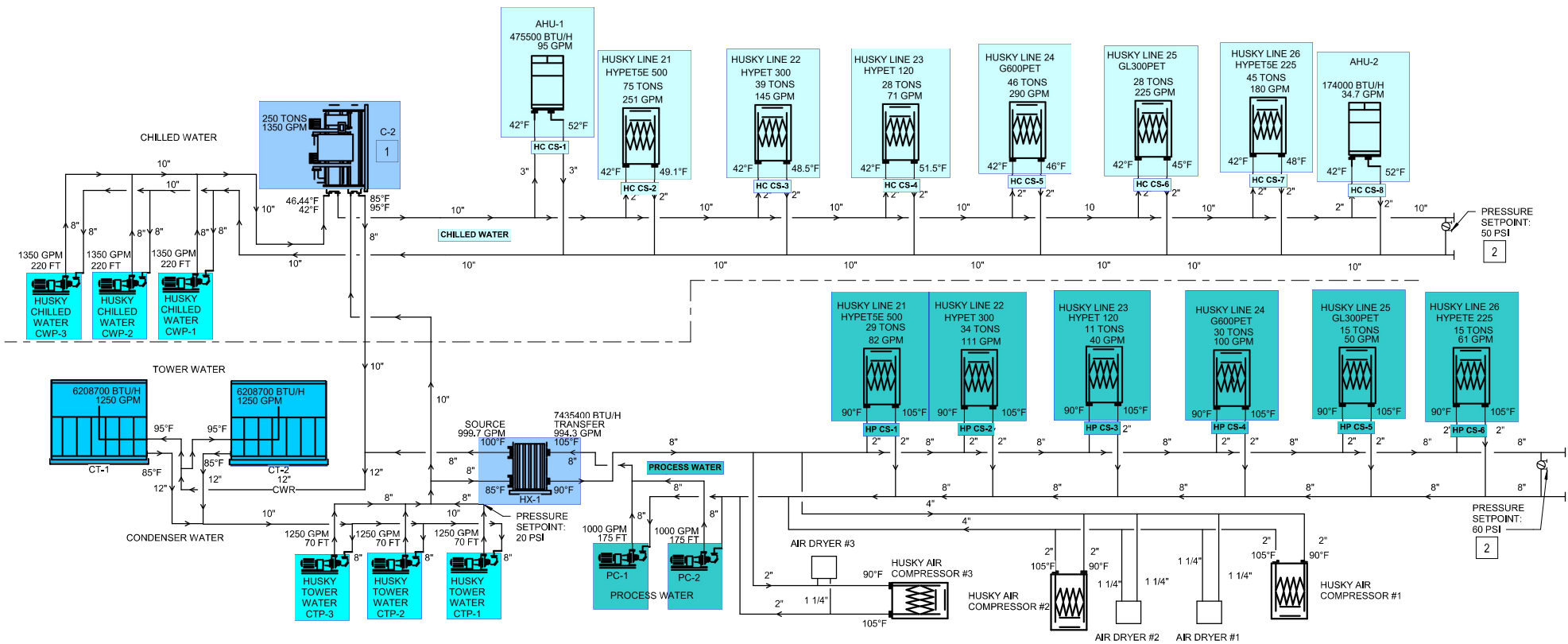

HUSKY PIPING DIAGRAM

KEYNOTES

- 1 CHILLER SUPPLY CHILLED WATER SETPOINT SHALL BE 42 DEGREES F.
- 2 WHEN TAB THE SYSTEM, ADJUST SYSTEM PRESSURE SETPOINT TO LOWEST PRESSURE TO MAINTAIN RELIABLE DESIGN FLOW RATES THRU EQUIPMENT.

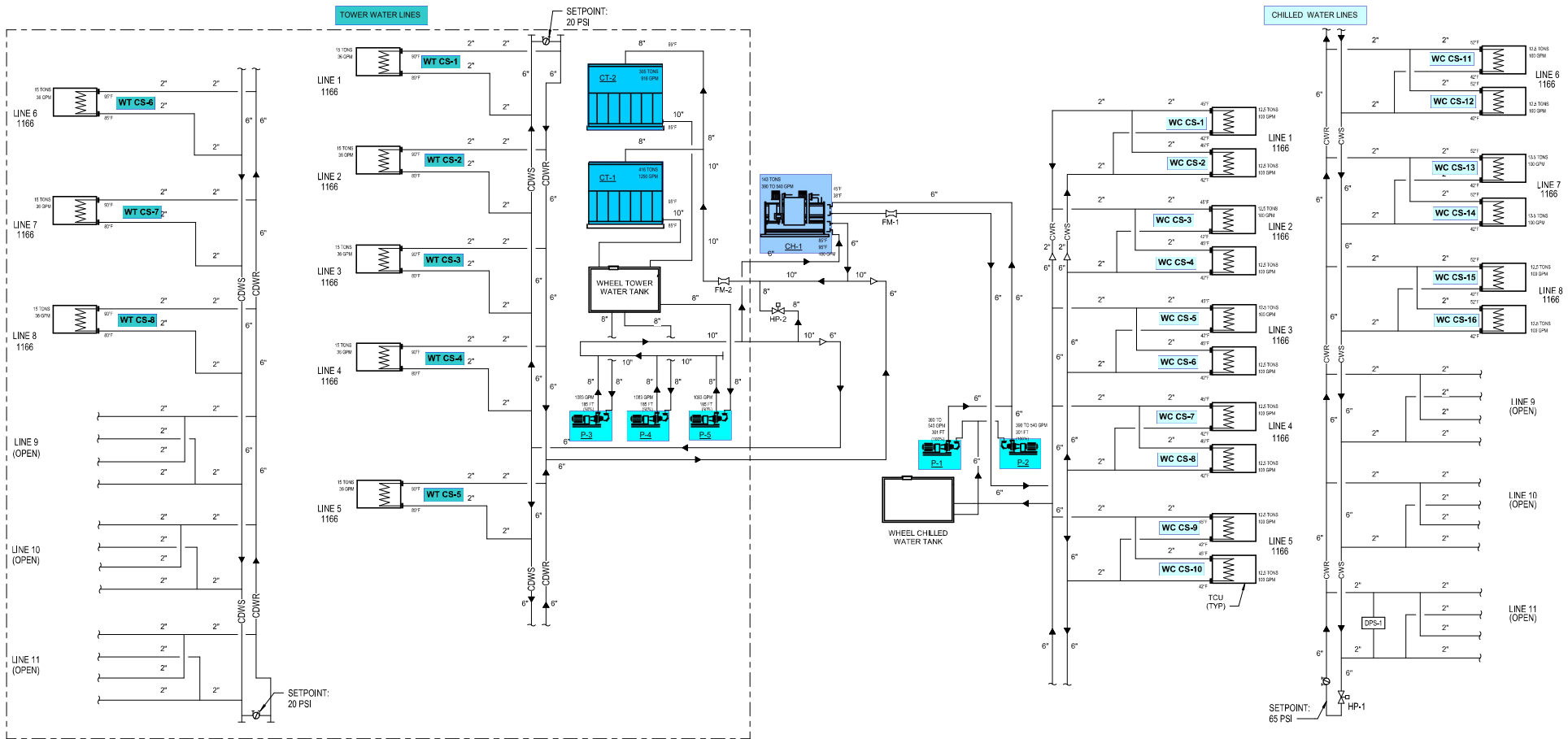

WHEEL PIPING DIAGRAM

SYSTEM SEQUENCE OF OPERATIONS

1. WHEEL SYSTEM CHILLED WATER PUMP (P-1 AND P-2) CONTROL:

ENERGIZE THE LEAD PUMP WHENEVER THE FACILITY EQUIPMENT REQUIRES COOLING. MONITOR PUMP STATUS THRU THE VARIABLE SPEED DRIVE. IF LEAD PUMP FAILS, ALARM TO SYSTEM AND START LAG PUMP. MONITOR CHILLED WATER DIFFERENTIAL PRESSURE, IN THE REMOTE END OF THE PIPING DISTRIBUTION SYSTEM (LOCATION INDICATED) BY DIFFERENTIAL PRESSURE SENSOR (DPS-1). THE PRESSURE SENSOR SHALL BE DIRECT WIRED AND CONNECTED TO THE PUMP SPEED CONTROLLER LOCATED IN THE MECHANICAL ROOM. MODULATE PUMP SPEED THROUGH THE PUMP VARIABLE SPEED CONTROLLER AS REQUIRED TO MAINTAIN SETPOINT (DPS-1), PERIODICALLY EVERY 7 DAYS, CHANGE THE ROLES OF LEAD AND LAG PUMPS.

2. WHEEL SYSTEM MINIMUM CHILLED WATER FLOWRATE:

CHILLED WATER SYSTEM SHALL HAVE TWO FLOWRATE SETPOINT OPTIONS:

- A. OPTION A (NORMAL FLOWRATE OPERATION): 400 GPM SETPOINT.
- B. OPTION B (HIGH FLOWRATE OPERATION): 530 GPM SETPOINT.

PLANT OPERATOR SHALL BE ABLE TO SELECT BETWEEN OPTION A AND B.

- MONITOR CHILLED WATER FLOWRATE WITH FLOW METER (FM1). MODULATE BYPASS VALVE (HS-1) TO MAINTAIN THE MINIMUM FLOWRATE SETPOINT. WHEN SYSTEM IS NOT IN OPERATION AND DURING SYSTEM START BYPASS VALVE (HS-2) SHALL FAIL TO THE OPEN POSITION.
- FOR OPTION A: WHEN CHILLED WATER FLOWRATE DROPS BELOW 400 GPM MODULATE BYPASS VALVE (HS-1) OPEN TO MAINTAIN A MINIMUM FLOWRATE OF 400 GPM. WHEN THE FLOWRATE INCREASES ABOVE 450 GPM MODULATE BYPASS VALVE (HS-1) CLOSED TO MAINTAIN A MINIMUM FLOWRATE OF 400 GPM.
- FOR OPTION B: WHEN CHILLED WATER FLOWRATE DROPS BELOW 470 GPM MODULATE BYPASS VALVE (HS-1) OPEN TO MAINTAIN A MINIMUM FLOWRATE OF 530 GPM. WHEN THE FLOWRATE INCREASES ABOVE 530 GPM MODULATE BYPASS VALVE (HS-1) CLOSED TO MAINTAIN A MINIMUM FLOWRATE OF 530 GPM.

3. WHEEL SYSTEM COOLING TOWER WATER BYPASS WATER CONTROL:

MONITOR COOLING TOWER WATER FLOWRATE WITH FLOW METER (FM2). THE WATER FLOWRATE SETPOINT IS 2,060 GPM. WHEN COOLING TOWER FLOWRATE DROPS BELOW 1,950 GPM MODULATE BYPASS VALVE (HS-2) OPEN TO MAINTAIN A MINIMUM FLOWRATE OF 2,060 GPM. WHEN THE FLOWRATE INCREASES ABOVE 2,165 GPM MODULATE BYPASS VALVE (HS-2) CLOSED TO MAINTAIN A MINIMUM FLOWRATE OF 2,060 GPM. WHEN SYSTEM IS NOT IN OPERATION AND DURING SYSTEM START BYPASS VALVE (HS-2) SHALL FAIL TO THE OPEN POSITION.