

Report By:

National TAB
1329 E. KEMPER ROAD
SUITE 4210
CINCINNATI, OH 45246



Report: TAB REPORT
Function: Test, Adjust, & Balance
Date: 03/07/2024

PROJECT

Altium Packaging - Cooling Water System (Lenexa, KS)

11725 W 85th Street

Overland Park, KS 66214

Client

Clark Nexsen
440 Martin Luther King Jr Blvd
Macon, GA 31201

National TAB

Project: Altium Packaging - Cooling Water System (Lenexa, KS)

Table Of Contents

Section	Page #
Summary	3
Pumps - Husky	5
Chiller - Husky	13
Water Tower - Husky	14
Flow Devices - Husky Process	16
Chilled Flow Devices - Husky	17
Pumps - Wheel	18
Chiller - Wheel	22
Water Towers - Wheel	23
Flow Devices - Wheel Process	25
Flow Devices - Wheel Chilled	26
Piping Plan	27

Project Summary

Phase 4

Phase 4 at Altium consisted of hydronic balancing for the Husky process water loop and the Husky tower loop. The process water loop includes two pumps, heat exchanger, and terminal flow devices. The tower loop consists of three pumps, heat exchanger, chiller, and two cooling towers.

TAB was first completed for the tower water loop. The pumps were set to design flow using the locking valves at the discharge of the pumps and calculating flow using the pumps' rated head for design GPM. The heat exchanger and chiller condenser were balanced using the locking valves. It should be noted that the design for the heat exchanger is 1000 GPM and Chiller condenser 750 GPM for total flow of 1750 CFM. However, each pump/cooling tower is rated for 1250 GPM. If only one pump is running, this would not satisfy the requirements for the heat exchanger and chiller so both pumps must run simultaneously to handle the connected load resulting in 2500GPM total flow design. There is no bypass present so full flow must pass through the heat exchanger and the chiller condenser. The chiller condenser was balanced to 904 GPM and the HX to 1582 GPM. The chiller condenser flow could not be balanced to within 10% of design due to limits with the notched butterfly valve so flow was left high instead of low. Closing the valve to the next locking position caused low flow. Flow distribution to the cooling towers was left as-is per the preliminary TAB survey performed prior to piping changes.

TAB was then completed for the process line water loop. The pumps were balanced via the locking valves at the discharge of the pump and setting to the pumps rated head. Once pumps were set to design flow the bypass valve was closed until the pressure in the supply header was at 45 PSI. With all bypass valves for the process machines closed, the pressure drop across each machine was found to be approximately 30 PSI as required. The bypass valves for each machine were set by first closing off flow to the machines then adjusting the bypass balancing valves until design flow was achieved. Note that flow could not be measured to the air compressors or air dryer also served by process water due to the lack of balance valves or pressure ports. No design criteria are provided for air compressors or air dryers.

Temperatures across applicable devices were not recorded since the system was not running with accurate heat loading from the husky line machines.

Phase 5

Summary Phase 5 at Altium consisted of hydronic balancing for the Husky chilled water loop. The chilled water loop includes three pumps, a chiller, and terminal flow devices. Note that Chilled pump number 2 does not run and was locked out during TAB. TAB was completed for the Chilled Husky system by testing each pump one at a time. Pump total flow was tested and confirmed to be in design flow. Next, the flow setpoint through the header bypass valve was calculated by subtracting the connected GPM load of the loop from the pump design GPM and the valve was adjusted to obtain that target GPM. Flow was then balanced to the two AHUs with the control valves fully open and flow was reduced to design using the balancing valves. Husky

machines were then balanced by using gate valves to obtain the design pressure drop through the machines with bypass valves closed. Bypass valves were balanced by shutting flow off to the machines and adjusting the handle positions to obtain design bypass flow. Once all valves and machines were balanced, the final pump and motor performance was collected with the final chiller pressure drop.

Phase 6

TAB was completed for the Wheel system which consists of two chilled water pumps, two process water pumps, 1 Water cooled chiller, and flow to terminal devices (packaging machines)

For the process water loop TAB was completed by setting the pump total flows via the triple duty valves since the process pumps do not run off a VFD. Once total flows were set Bypass valves on the headers were set based on connected flow calculation. $\text{Bypass flow} = \text{Pump rated flow} - \text{Machine design flow total}$. Once the header bypass valves were set, Machine bypass valves were set to match the machine design flow. After all bypass valves were set, final pump performance was documented and listed in the following report. It is recommended that for the most optimal system performance that when a process machine flow is opened that the corresponding bypass valve gets closed to push the flow through the machine.

TAB was completed for the Chilled water loop by setting the pump to run at 60Hz constantly. Once at a constant speed all machine bypass valves were set to a minimum flow setpoint to prevent stagnant water in the lines. The pump control pressure setpoint was set by Replicating a worst-case scenario which is having flow to four machines with the pump at 60hz and recording the Differential pressure of 64.4 and making this the control setpoint. Final pump performance was then recorded and included in the report below. The control system was tested by closing off the machines one at a time and verifying the pump slows down



National TAB

Project: Altium Packaging - Cooling Water System (Lenexa, KS)

System/Unit: Pump

Asset: CTP-1

AREA:HUSY MECH RM

Unit Data		
	Design	Actual
MFG	EXISTING	PACO
Model Num	EXISTING	1050957-1400081882
Serial Num	-	674200352-10
Service	-	TOWER WATER
Type	-	CENTRIFUGAL
Configuration	-	HORIZONTAL
Pump RPM	-	1750
GPM/HD	1250-70	1250-70
Impeller Diameter	-	9.42

Motor Data		
	Design	Actual
Motor MFG	-	BALDOR
Frame	-	286JH
Horsepower	30	30
Motor Rpm	-	1775
Phase	-	3
Voltage	-	460
Amperage	-	36
Service Factor	-	1.15
Efficiency	-	94.1
Power Factor	-	82

Test Data		
	Design	Actual
Act Impeller Dia (IN)	-	9.42
Valve Open GPM (FT)	-	1350
Valve Open Diff (FT)	-	59.94
Final Suction Pres (FT)	-	3.16
Final Discharge Pres (FT)	-	80.5
Total Head Pres (FT)	70	77.4
Final GPM	1250	1191
Pump Rotation	-	CORRECT
Motor RPM	-	1775
Pump RPM	-	1775
Motor Frequency	-	60HZ
System SetPt	-	VALVE POSITION: 4
RL Voltage	-	472
RL Amperage	-	31 ANALOG GAUGE
Brake Horse Power	-	25.8

Completed By: Tyler Youells on 08/25/2023



National TAB

Project: Altium Packaging - Cooling Water System (Lenexa, KS)

System/Unit: Pump

Asset: CTP-2

AREA:HUSY MECH RM

Unit Data		
	Design	Actual
MFG	EXISTING	PACO
Model Num	EXISTING	1050957
Serial Num	-	203012
Service	-	TOWER WATER
Type	-	CENTRIFUGAL
Configuration	-	HORIZONTAL
Pump RPM	-	1750
GPM/HD	1250-70	1250-70
Impeller Diameter	-	9.45

Motor Data		
	Design	Actual
Motor MFG	-	WEG
Frame	-	286JH
Horsepower	30	30
Motor Rpm	-	1765
Phase	-	3
Voltage	-	460
Amperage	-	35.1
Service Factor	-	1.15
Efficiency	-	93.6
Power Factor	-	0.84

Test Data		
	Design	Actual
Act Impeller Dia (IN)	-	9.45
Valve Open GPM (FT)	-	1295
Valve Open Diff (FT)	-	65.2
Final Suction Pres (FT)	-	1.9
Final Discharge Pres (FT)	-	78.7
Total Head Pres (FT)	70	76.8
Final GPM	1250	1193
Pump Rotation	-	CORRECT
Motor RPM	-	1765
Pump RPM	-	1765
Motor Frequency	-	60HZ
System SetPt	-	VALVE POSITION: 5
RL Voltage	-	472
RL Amperage	-	29
Brake Horse Power	-	24.8

Completed By: Tyler Youells on 08/25/2023



National TAB

Project: Altium Packaging - Cooling Water System (Lenexa, KS)

System/Unit: Pump

Asset: CTP-3

AREA:HUSY MECH RM

Unit Data		
	Design	Actual
MFG	EXISTING	PACO
Model Num	EXISTING	1050957140001181
Serial Num	-	SP-E13413-0701
Service	-	TOWER WATER
Type	-	CENTRIFUGAL
Configuration	-	HORIZONTAL
Pump RPM	-	1750
GPM/HD	1250-70	1250-70
Impeller Diameter	-	9.6"

Motor Data		
	Design	Actual
Motor MFG	-	BALDOR
Frame	-	286JH
Horsepower	30	30
Motor Rpm	-	1760
Phase	-	3
Voltage	-	460
Amperage	-	36
Service Factor	-	1.15
Efficiency	-	92.4
Power Factor	-	84

Test Data		
	Design	Actual
Act Impeller Dia (IN)	-	9.6"
Valve Open GPM (FT)	-	1227
Valve Open Diff (FT)	-	72.6
Final Suction Pres (FT)	-	2.68
Final Discharge Pres (FT)	-	75.3
Total Head Pres (FT)	70	72.6
Final GPM	1250	1227
Pump Rotation	-	CORRECT
Motor RPM	-	1775
Pump RPM	-	1775
Motor Frequency	-	60HZ
System SetPt	-	VALVE POSITION: FULL OPEN
RL Voltage	-	472
RL Amperage	-	36
Brake Horse Power	-	30.0

Completed By: Tyler Youells on 08/25/2023



National TAB

Project: Altium Packaging - Cooling Water System (Lenexa, KS)

System/Unit: Pump

Asset: CWP-1

AREA:HUSY MECH RM

Unit Data		
	Design	Actual
MFG	EXISTING	PACO
Model Num	EXISTING	11-50157-158201
Serial Num	-	197100369210
Service	-	CHILLED WATER LOOP
Type	-	CENTRIFUGAL
Configuration	-	HORIZONTAL
Pump RPM	-	NL
GPM/HD	1350-200	1350-220
Impeller Diameter	-	15.00

Motor Data		
	Design	Actual
Motor MFG	-	BALDOR RELIANCE
Frame	-	405T
Horsepower	125	125
Motor Rpm	-	1775
Phase	-	3
Voltage	-	460
Amperage	-	143
Service Factor	-	1.15
Efficiency	-	95.4%
Power Factor	-	86%

Test Data		
	Design	Actual
Act Impeller Dia (IN)	-	14.88
Valve Open GPM (FT)	-	1393
Valve Open Diff (FT)	-	206.5
Final Suction Pres (FT)	-	25.63
Final Discharge Pres (FT)	-	232.1
Total Head Pres (FT)	-	206.5
Final GPM	-	1393
Pump Rotation	-	CORRECT
Motor RPM	-	1775
Pump RPM	-	1775
Motor Frequency	-	60HZ
System SetPt	-	FULL OPEN
RL Voltage	-	473
RL Amperage	-	124
Brake Horse Power	-	107.5

Completed By: Tyler Youells on 09/18/2023



National TAB

Project: Altium Packaging - Cooling Water System (Lenexa, KS)

System/Unit: Pump

Asset: CWP-2

AREA:HUSY MECH RM

Unit Data		
	Design	Actual
MFG	EXISTING	PACO
Model Num	EXISTING	11-50157-158201
Serial Num	-	197101766010
Service	-	CHILLED WATER
Type	-	CENTRIFUGAL
Configuration	-	HORIZONTAL
Pump RPM	-	1775
GPM/HD	1350-200	1500-210
Impeller Diameter	-	15.00

Motor Data		
	Design	Actual
Motor MFG	-	BALDOR
Frame	-	405T
Horsepower	125	125
Motor Rpm	-	1775
Phase	-	3
Voltage	-	460
Amperage	-	145
Service Factor	-	1.15
Efficiency	-	94.5%
Power Factor	-	85%

Test Data		
	Design	Actual
Pump Off Pres	-	-
Pump Dead Head Pres	-	-
Act Impeller Dia (IN)	-	-
Valve Open GPM (FT)	-	-
Valve Open Diff (FT)	-	-
Final Suction Pres (FT)	-	-
Final Discharge Pres (FT)	-	-
Total Head Pres (FT)	-	-
Final GPM	-	-
Pump Rotation	-	-
Motor RPM	-	-
Pump RPM	-	-
Motor Frequency	-	-
System SetPt	-	-
RL Voltage	-	-
RL Amperage	-	-
Brake Horse Power	-	-

Completed By: Tyler Youells on 09/18/2023

Notes:

Pump/Motor is locked out and does not run. unable to perform TAB and verify flow.

Written By: Tyler Youells on 09/18/2023



National TAB

Project: Altium Packaging - Cooling Water System (Lenexa, KS)

System/Unit: Pump

Asset: CWP-3

AREA:HUSY MECH RM

Unit Data		
	Design	Actual
MFG	EXISTING	PACO
Model Num	EXISTING	11-50157-158201
Serial Num	-	1971089264-10
Service	-	CHILLED WATER LOOP
Type	-	CENTRIFUGAL
Configuration	-	HORIZONTAL
Pump RPM	-	NL
GPM/HD	1350-200	1350-220
Impeller Diameter	-	14.88

Motor Data		
	Design	Actual
Motor MFG	-	BALDOR RELIANCE
Frame	-	405T
Horsepower	125	125
Motor Rpm	-	1775
Phase	-	3
Voltage	-	460
Amperage	-	143
Service Factor	-	1.15
Efficiency	-	95.4%
Power Factor	-	86%

Test Data		
	Design	Actual
Act Impeller Dia (IN)	-	14.88
Valve Open GPM (FT)	-	1412
Valve Open Diff (FT)	-	201
Final Suction Pres (FT)	-	25.8
Final Discharge Pres (FT)	-	227
Total Head Pres (FT)	-	201
Final GPM	-	1412
Pump Rotation	-	CORRECT
Motor RPM	-	1775
Pump RPM	-	1775
Motor Frequency	-	60HZ
System SetPt	-	FULL OPEN
RL Voltage	-	473
RL Amperage	-	125 ANALOG
Brake Horse Power	-	109.2

Completed By: Tyler Youells on 09/18/2023



National TAB

Project: Altium Packaging - Cooling Water System (Lenexa, KS)

System/Unit: Pump

Asset: PC-1

AREA:HUSY MECH RM

Unit Data		
	Design	Actual
MFG	EXISTING	PACO
Model Num	EXISTING	1040959-1A000
Serial Num	-	NL
Service	-	PROCESS WATER
Type	-	CENTRIFUGAL
Configuration	-	HORIZONTAL
Pump RPM	-	3500
GPM/HD	1000-175	1000-175
Impeller Diameter	-	NL

Motor Data		
	Design	Actual
Motor MFG	-	WEG
Frame	-	324/6JM
Horsepower	60	60
Motor Rpm	-	3560
Phase	-	3
Voltage	-	460
Amperage	-	71
Service Factor	-	1.25
Efficiency	-	93.6
Power Factor	-	0.85

Test Data		
	Design	Actual
Valve Open GPM (FT)	-	1217
Valve Open Diff (FT)	-	118
Final Suction Pres (FT)	-	35.5
Final Discharge Pres (FT)	-	195
Total Head Pres (FT)	-	160
Final GPM	-	1045
Pump Rotation	-	CORRECT
Motor RPM	-	3650
Pump RPM	-	3650
Motor Frequency	-	60HZ
System SetPt	-	VALVE POSTION: 3
RL Voltage	-	472
RL Amperage	-	67 (ANALOG)
Brake Horse Power	-	56.6

Completed By: Tyler Youells on 08/25/2023



National TAB

Project: Altium Packaging - Cooling Water System (Lenexa, KS)

System/Unit: Pump

Asset: PC-2

AREA:HUSY MECH RM

Unit Data		
	Design	Actual
MFG	EXISTING	PACO
Model Num	EXISTING	10-40959-1A0001-1911
Serial Num	-	148288
Service	-	PROCESS WATER
Type	-	CENTRIFUGAL
Configuration	-	HORIZONTAL
Pump RPM	-	3500
GPM/HD	1110-160	1110-160
Impeller Diameter	-	NL

Motor Data		
	Design	Actual
Motor MFG	-	WEG
Frame	-	326JM
Horsepower	60	60
Motor Rpm	-	3555
Phase	-	3
Voltage	-	460
Amperage	-	70.6
Service Factor	-	1.15
Efficiency	-	93
Power Factor	-	0.86

Test Data		
	Design	Actual
Valve Open GPM (FT)	-	1154
Valve Open Diff (FT)	-	148
Final Suction Pres (FT)	-	42
Final Discharge Pres (FT)	-	211.5
Total Head Pres (FT)	-	169.9
Final GPM	-	1077
Pump Rotation	-	CORRECT
Motor RPM	-	3555
Pump RPM	-	3555
Motor Frequency	-	60HZ
System SetPt	-	VALVE POSITION: 4
RL Voltage	-	472
RL Amperage	-	70 (ANALOG)
Brake Horse Power	-	59.4

Completed By: Tyler Youells on 08/25/2023



National TAB

Project: Altium Packaging - Cooling Water System (Lenexa, KS)

System/Unit: Chiller

Asset: C-2

AREA:

Unit Data		
	Design	Actual
MFG	na	YORK
Model Num	na	YSDCCBS2-CJES
Serial Num	-	SHKM-483390
Type	-	WATER COOLED
Service	-	PROCESS/TOWER LOOP

Test Data-Evaporator		
	Design	Actual
GPM	1350	1412
Balance Valve Setting	-	FULL OPEN
EWT (F)	46.4	50
LWT (F)	42	48
Water Temp Delta T (F)	-	2
CHW Delta P	16.1 FT	17.6FT

Test Data-Condenser		
	Design	Actual
CW GPM	750	801
Balance Valve Setting	-	4
EWT (F)	85	76
LWT (F)	95	80
Water Temp Delta T (F)	-	4
CHW Delta P	10.1 FT	11.5FT

Completed By: Tyler Youells on 09/18/2023



National TAB

Project: Altium Packaging - Cooling Water System (Lenexa, KS)

System/Unit: Water Tower

Asset: CT-1

AREA:OUTDOOR HUSKY MECH RM

Unit Data		
	Design	Actual
MFG	EXISTING	MARLEY SPX
Model Num	EXISTING	10155187 B1NC8407QAN1BGF

Test Data		
	Design	Actual
CW GPM	1250	1192
EWT (F)	95.0	NO LOAD
LWT (F)	85.0	NO LOAD

Completed By: Tyler Youells on 08/25/2023



National TAB

Project: Altium Packaging - Cooling Water System (Lenexa, KS)

System/Unit: Water Tower

Asset: CT-2

AREA:OUTDOOR HUSKY MECH RM

Unit Data		
	Design	Actual
MFG	EXISTING	MARLEY SPX
Model Num	EXISTING	10155187 A1NC8407QAN1BGF

Test Data		
	Design	Actual
CW GPM	1250	1192
EWT (F)	95.0	NO LOAD
LWT (F)	85.0	NO LOAD

Completed By: Tyler Youells on 08/25/2023



National TAB

Project: Altium Packaging - Cooling Water System (Lenexa, KS)

HUSKY PROCESS VALVES

Area Served	MFG	Size	Type	Design GPM	Actual GPM	Delta P Design (PSI)	Delta P Actual (PSI)	Entering P (PSI)	Leaving P (PSI)	Valve Position
Line 21	NA	NA	BUTTERFLY	82	86	30	33	52	19	FULL OPEN
Line 21 Bypass	RWV	3"	MANUAL CS	82	82.7	NA	26.75	NA	NA	2.5
Line 22	NA	NA	BUTTERFLY	111	116	30	32.8	52	18.5	FULL OPEN
Line 22 Bypass	RWV	3"	MANUAL CS	111	115	NA	28.2	NA	NA	3.2
Line 23	NA	NA	BUTTERFLY	40	42	30	33.06	49.6	16.6	FULL OPEN
Line 23 Bypass	RWV	2"	MANUAL CS	40	39.8	NA	2.587	NA	NA	2.5
Line 24	NA	NA	BUTTERFLY	100	103.8	30	32.32	50.36	18.13	FULL OPEN
Line 24 Bypass	RWV	3"	MANUAL CS	100	100.5	NA	27.06	NA	NA	3
Line 25	NA	NA	BUTTERFLY	50	52.2	30	32.75	50.9	18.18	FULL OPEN
Line 25 Bypass	RWV	2"	MANUAL CS	50	49.5	NA	2.98	NA	NA	3
Line 26	NA	NA	NA	61	NA	NA	NA	NA	NA	NA
Line 26 Bypass	NA	NA	NA	61	NA	NA	NA	NA	NA	NA
EOR Bypass	RMV	NA	MANUAL CS	NA	NA	NA	NA	49.2	16.1	2

Notes:

Line 26 machine not installed. Pipe rough-ins are present but they are closed off



National TAB

Project: Altium Packaging - Cooling Water System (Lenexa, KS)

Circuit Setter

HUSKY CHILLED FLOW DEVICES/

Asset								
Asset Name	Size	Type	Service	Design GPM	Setting	Delta P	Final GPM	% to Design
CS1	3"	MANUAL	AHU-1	95	50	128FT	99	104.2
CS2	4"	MANUAL	LINE 21	251	2.8	60 PSI	265	105.6
CS3	3"	MANUAL	LINE 22	145	3.5	40.9 PSI	162	111.7
CS4	2.5"	MANUAL	LINE 23	71	1.2	56PSI	75	105.6
CS5	4"	MANUAL	LINE 24	290	2.8	69 PSI	285	98.3
CS6	4"	MANUAL	LINE 25	255	5	3.7 PSI	238	93.3
CS7	NA	NA	LINE 26	180	NA	NA	0	0.0
CS8	2"	MANUAL	AHU-2	34.7	3.5	1.7 PSI	32.9	94.8
CS9	4"	MANUAL	MAIN HEADER BYPASS	28.3	4	68 PSI	281	992.9
Total				1350			1437.9	106.51%

Asset	Notes	Date	Written By
CS9	BYPASS FLOW INCREASED DUE TO LINE 26 NOTE EXISTING	10/02/2023	Tyler Youells



National TAB

Project: Altium Packaging - Cooling Water System (Lenexa, KS)

System/Unit: Pump

Asset: P-1

AREA:WHEEL MECH RM

Unit Data		
	Design	Actual
MFG	B&G	B&G
Model Num	4BD	2.5BB
Serial Num	-	C349466-01
Service	-	CHILLED WATER
Type	-	CENTRIFUGAL
Configuration	-	END SUCTION
Pump RPM	-	3600
GPM/HD	500/180	500-180
Impeller Diameter	7.5	7.5

Motor Data		
	Design	Actual
Motor MFG	-	BALDOR RELIANCE
Frame	-	286JM
Horsepower	40	40
Motor Rpm	-	3510
Phase	-	3
Voltage	-	460
Amperage	-	45
Service Factor	-	1.15
Efficiency	-	92.4
Power Factor	-	0.90

Test Data		
	Design	Actual
Act Impeller Dia (IN)	-	7.5
Valve Open GPM (FT)	-	504
Valve Open Diff (FT)	-	177.4
Final Suction Pres (FT)	-	25.9 PSI
Final Discharge Pres (FT)	-	109.5 PSI
Total Head Pres (FT)	-	193 FT
Final GPM	-	483
Pump Rotation	-	CORRECT
Motor RPM	-	3550
Pump RPM	-	3550
Motor Frequency	-	@60 HZ
System SetPt	-	64.4 PSI DP
RL Voltage	-	459.9 V
RL Amperage	-	37.6 A

Completed By: Tyler Youells on 11/14/2023



National TAB

Project: Altium Packaging - Cooling Water System (Lenexa, KS)

System/Unit: Pump

Asset: P-2

AREA:WHEEL MECH RM

Unit Data		
	Design	Actual
MFG	B&G	B&G
Model Num	4BD	2.5BB
Serial Num	-	C349466-02
Service	-	CHILLED WATER
Type	-	CENTRIFUGAL
Configuration	-	END SUCTION
Pump RPM	-	3600
GPM/HD	500/180	500-180
Impeller Diameter	7.5	7.5

Motor Data		
	Design	Actual
Motor MFG	-	BALDOR RELIANCE
Frame	-	286JM
Horsepower	40	40
Motor Rpm	-	3510
Phase	-	3
Voltage	-	460
Amperage	-	45
Service Factor	-	1.15
Efficiency	-	92.4
Power Factor	-	0.90

Test Data		
	Design	Actual
Act Impeller Dia (IN)	-	7.5
Valve Open GPM (FT)	-	482
Valve Open Diff (FT)	-	193.8 FT
Final Suction Pres (FT)	-	26.8 PSI
Final Discharge Pres (FT)	-	110.8 PSI
Total Head Pres (FT)	-	193.8 FT
Final GPM	-	482
Pump Rotation	-	CORRECT
Motor RPM	-	3510
Pump RPM	-	3510
Motor Frequency	-	@60HZ
System SetPt	-	64.4 PSI DP
RL Voltage	-	459.9 V
RL Amperage	-	38 A

Completed By: Tyler Youells on 11/14/2023



National TAB

Project: Altium Packaging - Cooling Water System (Lenexa, KS)

System/Unit: Pump

Asset: P-3

AREA:WHEEL MECH RM

Unit Data		
	Design	Actual
MFG	B&G	B&G
Model Num	4BD	4BD
Serial Num	-	NL
Service	-	PROCESS WATER
Type	-	CENTRIFUGAL
Configuration	-	END SUCTION
Pump RPM	-	3550
GPM/HD	1250/162	1250/162
Impeller Diameter	7.75	7.75

Motor Data		
	Design	Actual
Motor MFG	-	WEG
Frame	-	364/5TS
Horsepower	75	75
Motor Rpm	-	3555
Phase	-	3
Voltage	-	460
Amperage	-	84.8
Service Factor	-	1.25
Efficiency	-	93.6
Power Factor	-	0.87

Test Data		
	Design	Actual
Act Impeller Dia (IN)	-	7.75
Valve Open GPM (FT)	-	1438
Valve Open Diff (FT)	-	127 FT
Final Suction Pres (FT)	-	0.97 PSI
Final Discharge Pres (FT)	-	68.9 PSI
Total Head Pres (FT)	168	157
Final GPM	-	1293
Pump Rotation	-	CORRECT
Motor RPM	-	3550
Pump RPM	-	3550
Motor Frequency	-	60HZ
System SetPt	-	15% TRIPLE DUTY
RL Voltage	-	469V
RL Amperage	-	72.1A

Completed By: Tyler Youells on 11/14/2023



National TAB

Project: Altium Packaging - Cooling Water System (Lenexa, KS)

System/Unit: Pump

Asset: P-4

AREA:WHEEL MECH RM

Unit Data		
	Design	Actual
MFG	B&G	B&G
Model Num	4BD	4BD
Serial Num	-	NL
Service	-	PROCESS
Type	-	CENTRIFUGAL
Configuration	-	END SUCTION
Pump RPM	-	3550
GPM/HD	-	1250162
Impeller Diameter	-	7.75

Motor Data		
	Design	Actual
Motor MFG	-	WEG
Frame	-	364/5TS
Horsepower	-	75
Motor Rpm	-	3550
Phase	-	3
Voltage	-	460
Amperage	-	84.8
Service Factor	-	1.25
Efficiency	-	93.6
Power Factor	-	0.87

Test Data		
	Design	Actual
Act Impeller Dia (IN)	-	7.75
Valve Open GPM (FT)	-	1544
Valve Open Diff (FT)	-	110.1
Final Suction Pres (FT)	-	0.973PSI
Final Discharge Pres (FT)	-	68.93 PSI
Total Head Pres (FT)	-	156.8
Final GPM	-	1294
Pump Rotation	-	CORRECT
Motor RPM	-	3550
Pump RPM	-	3550
Motor Frequency	-	60HZ
System SetPt	-	15% TRIPLE DUTY
RL Voltage	-	470V
RL Amperage	-	70.3A

Completed By: Tyler Youells on 11/14/2023



National TAB

Project: Altium Packaging - Cooling Water System (Lenexa, KS)

System/Unit: Chiller

Asset: CHLR1

AREA:WHEEL ROOM

Unit Data		
	Design	Actual
MFG	TRANE	TRANE
Model Num	RTWD 160F 2L02 A1A1 AA2A 1A1Y 1B0A 0000 1000 000A	RTWD 160F 2L02 A1A1 AA2A 1A1Y 1B0A 0000 1000 000A
Serial Num	-	U20B06007
Type	-	WATER COOLED
Service	-	WHEEL LINE

Test Data-Evaporator		
	Design	Actual
GPM	-	483
Balance Valve Setting	-	N/A
EWT (F)	-	49
LWT (F)	-	42
Water Temp Delta T (F)	-	7 DEG
ENT Water Pres	-	109.1 PSI
LVG Water Pres	-	97.79 PSI
CHW Delta P	-	26.08FT

Test Data-Condenser		
	Design	Actual
CW GPM	480	477
Balance Valve Setting	-	8.0
EWT (F)	-	78
LWT (F)	-	80
Water Temp Delta T (F)	-	2
ENT Water Pres	-	21.92 PSI
LVG Water Pres	-	12.09 PSI
CHW Delta P	20.7FT	22.8 FT

Completed By: Tyler Youells on 01/03/2024

Notes:
CONDENSOR FLOW BALANCED USING GATE VALVE, BALANCE VALVE WAS DAMAGED (BALANCED VALVE WAS REPLACED PRIOR TO LEAVING AND VALVE WAS BALANCED)

Written By: Tyler Youells on 01/03/2024



National TAB

Project: Altium Packaging - Cooling Water System (Lenexa, KS)

System/Unit: Water Tower

Asset: CT-1

AREA:OUTDOOR WHEEL MECH RM

Unit Data

	Design	Actual
MFG	EXISTING	MARLEY
Model Num	EXISTING	NC8405QAN1BGF
Serial Num	-	10155180-A1

Test Data

	Design	Actual
CW GPM	1250	1293
EWT (F)	95.0	NO ACCESS
LWT (F)	85.0	NO ACCESS
Tower Water Pres Delta P	-	NO ACCESS

Completed By: Tyler Youells on 11/14/2023



National TAB

Project: Altium Packaging - Cooling Water System (Lenexa, KS)

System/Unit: Water Tower

Asset: CT-2

AREA:OUTDOOR WHEEL MECH RM

Unit Data		
	Design	Actual
MFG	EXISTING	MARLEY
Model Num	EXISTING	P15HG-1
Serial Num	-	247441

Test Data		
	Design	Actual
CW GPM	918	0
EWT (F)	95.0	0
LWT (F)	85.0	0
Tower Water Pres Delta P	-	0

Completed By: Tyler Youells on 11/14/2023

Notes:
COOLING TOWER NOT IN USE

Written By: Tyler Youells on 11/14/2023



National TAB

Project: Altium Packaging - Cooling Water System (Lenexa, KS)

Circuit Setter

WHEEL PROCESS FLOW DEVICES/

Asset									
Asset Name	Size	Type	Service	Design GPM	Cv	Setting	Delta P	Final GPM	% to Design
CS1	2"	MANUAL	LINE 1 BYPASS	36	63.67	2.5	0.35 PSI	38	105.6
CS2	2"	MANUAL	LINE 2 BYPASS	36	63.67	2.4	0.32PSI	36	100.0
CS3	NA	NA	NA	36	NA	0	0	0	0.0
CS4	2"	MANUAL	LINE 4 BYPASS	36	63.67	3.0	0.32 PSI	36	100.0
CS5	2"	MANUAL	LINE 5 BYPASS	36	63.67	2.4	0.308 PSI	35.3	98.1
CS6	2"	MANUAL	LINE 6 BYPASS	36	63.67	2.6	0.31 PSI	35.4	98.3
CS7	2"	MANUAL	LINE 7 BYPASS	36	63.67	2.5	0.35	38	105.6
CS8	2"	MANUAL	LINE 8 BYPASS	36	63.67	2.6	0.34 PSI	37	102.8
CS9	2"	MANUAL	LINE 9 BYPASS	36	63.67	2.5	0.33PSI	36.6	101.7
CS10	2"	MANUAL	LINE 10 BYPASS	36	63.67	2.6	0.32 PSI	36	100.0
CS11	2"	MANUAL	LINE 11 BYPASS	36	63.67	2.7	0.35 PSI	38	105.6
CS12	6"	MANUAL	HEADER BYPASS (LINE 1)	100	26.98	1.7	7.65PSI	74.6	74.6
CS13	6"	MANUAL	HEADER BYPASS (LINE 12)	238	82.03	2.8	5.71 PSI	196	82.4
CS14	2"	MANUAL	LAIKOS FILTER	85	63.67	4.0	2.08PSI	92	108.2
CS15	6"	MANUAL	CHILLER	480	NA	8.0	1.22 PSI	477	99.4
Total				1299				1205.9	92.83%



National TAB

Project: Altium Packaging - Cooling Water System (Lenexa, KS)

Circuit Setter

WHEEL CHILLED FLOW DEVICES/

Asset									
Asset Name	Size	Type	Service	Design GPM	Cv	Setting	Delta P	Final GPM	% to Design
CS1	3/4"	MANUAL	LINE 1 BYPASS	2	6.16	0.1	0.218 PSI	2.87	145.0
CS2	3/4"	MANUAL	LINE 2 BYPASS	2	6.16	0.1	0.233 PSI	2.97	150.0
CS3	NA	MANUAL	LINE 3 BYPASS	2	6.16	NA	NA	0	0.0
CS4	3/4"	MANUAL	LINE 4 BYPASS	2	6.16	0.1	0.262 PSI	3.15	160.0
CS5	3/4"	MANUAL	LINE 5 BYPASS	2	6.16	0.1	0.251 PSI	3.08	155.0
CS6	3/4"	MANUAL	LINE 6 BYPASS	2	6.16	0.1	0.257 PSI	3.12	155.0
CS7	3/4"	MANUAL	LINE 7 BYPASS	2	6.16	0.1	0.241 PSI	3.02	150.0
CS8	3/4"	MANUAL	LINE 8 BYPASS	2	6.16	0.1	0.250 PSI	3.08	155.0
CS9	3/4"	MANUAL	LINE 9 BYPASS	2	6.16	0.1	0.239 PSI	3.01	150.0
CS10	3/4"	MANUAL	LINE 10 BYPASS	2	6.16	0.1	0.252 PSI	3.09	155.0
CS11	3/4"	MANUAL	LINE 11 BYPASS	2	6.16	0.1	0.282 PSI	3.27	165.0
Total				22				30.6599999999 99997	139.36%

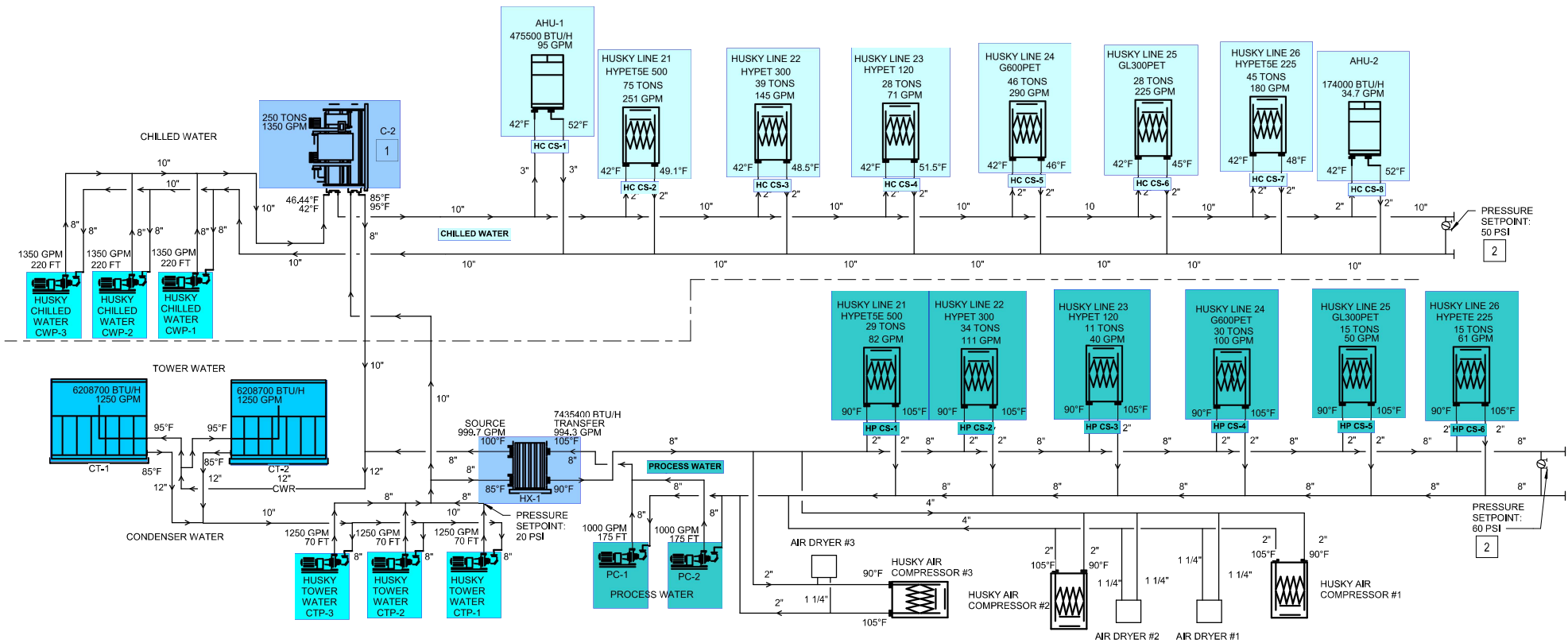

HUSKY PIPING DIAGRAM

KEYNOTES

- 1 CHILLER SUPPLY CHILLED WATER SETPOINT SHALL BE 42 DEGREES F.
- 2 WHEN TAB THE SYSTEM, ADJUST SYSTEM PRESSURE SETPOINT TO LOWEST PRESSURE TO MAINTAIN RELIABLE DESIGN FLOW RATES THRU EQUIPMENT.

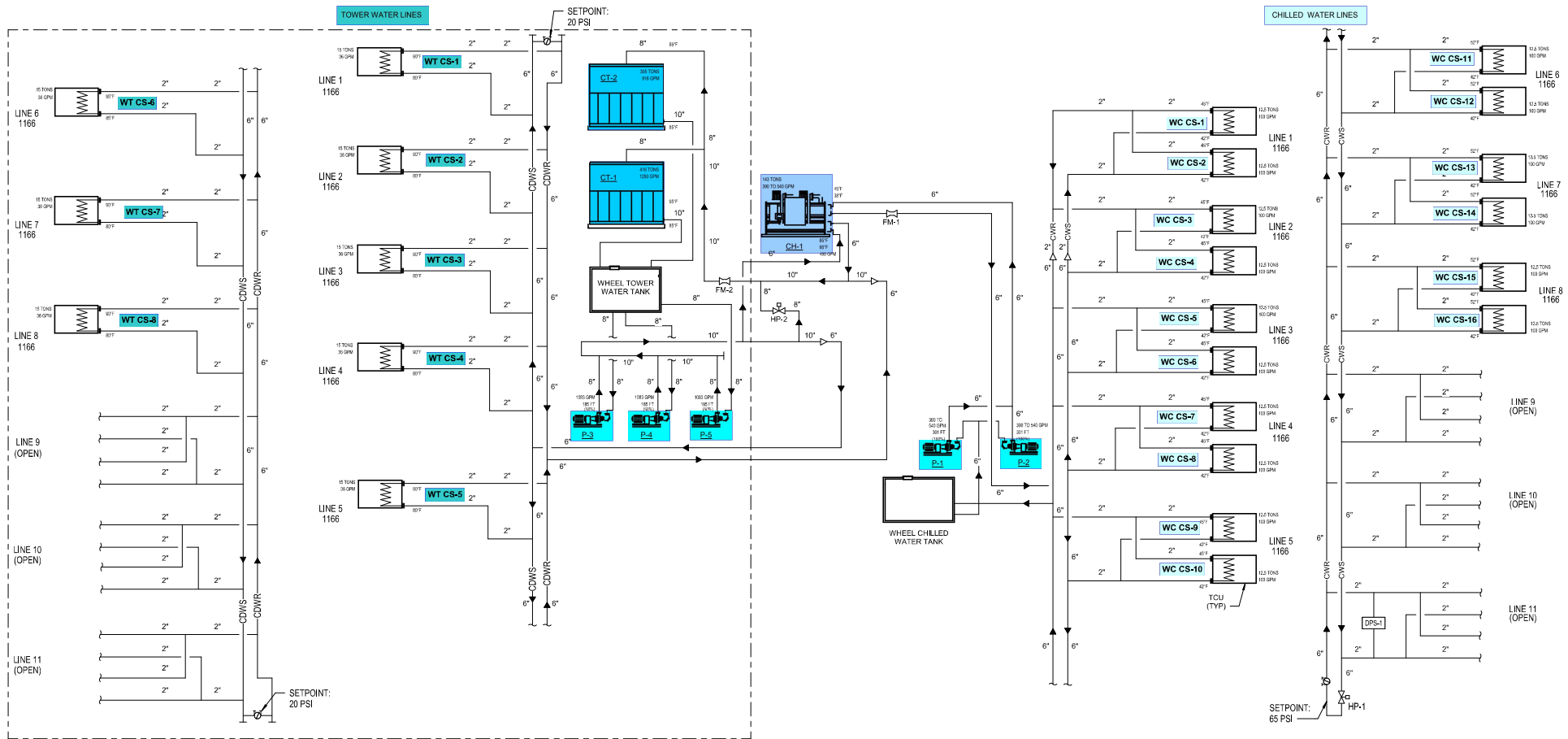

WHEEL PIPING DIAGRAM

SYSTEM SEQUENCE OF OPERATIONS

1. WHEEL SYSTEM CHILLED WATER PUMP (P-1 AND P-2) CONTROL:

ENERGIZE THE LEAD PUMP WHENEVER THE FACILITY EQUIPMENT REQUIRES COOLING. MONITOR PUMP STATUS THRU THE VARIABLE SPEED DRIVE. IF LEAD PUMP FAILS, ALARM TO SYSTEM AND START LAG PUMP. MONITOR CHILLED WATER DIFFERENTIAL PRESSURE, IN THE REMOTE END OF THE PIPING DISTRIBUTION SYSTEM (LOCATION INDICATED) BY DIFFERENTIAL PRESSURE SENSOR (DPS-1). THE PRESSURE SENSOR SHALL BE DIRECT WIRED AND CONNECTED TO THE PUMP SPEED CONTROLLER LOCATED IN THE MECHANICAL ROOM. MODULATE PUMP SPEED THROUGH THE PUMP VARIABLE SPEED CONTROLLER AS REQUIRED TO MAINTAIN SETPOINT (DPS-1), PERIODICALLY EVERY 7 DAYS, CHANGE THE ROLES OF LEAD AND LAG PUMPS.

2. WHEEL SYSTEM MINIMUM CHILLED WATER FLOWRATE:

CHILLED WATER SYSTEM SHALL HAVE TWO FLOWRATE SETPOINT OPTIONS:

- A. OPTION A (NORMAL FLOWRATE OPERATION): 400 GPM SETPOINT.
- B. OPTION B (HIGH FLOWRATE OPERATION): 530 GPM SETPOINT.

PLANT OPERATOR SHALL BE ABLE TO SELECT BETWEEN OPTION A AND B.

- MONITOR CHILLED WATER FLOWRATE WITH FLOW METER (FM1). MODULATE BYPASS VALVE (HS-1) TO MAINTAIN THE MINIMUM FLOWRATE SETPOINT. WHEN SYSTEM IS NOT IN OPERATION AND DURING SYSTEM START BYPASS VALVE (HS-2) SHALL FAIL TO THE OPEN POSITION.
- FOR OPTION A: WHEN CHILLED WATER FLOWRATE DROPS BELOW 400 GPM MODULATE BYPASS VALVE (HS-1) OPEN TO MAINTAIN A MINIMUM FLOWRATE OF 400 GPM. WHEN THE FLOWRATE INCREASES ABOVE 450 GPM MODULATE BYPASS VALVE (HS-1) CLOSED TO MAINTAIN A MINIMUM FLOWRATE OF 400 GPM.
- FOR OPTION B: WHEN CHILLED WATER FLOWRATE DROPS BELOW 470 GPM MODULATE BYPASS VALVE (HS-1) OPEN TO MAINTAIN A MINIMUM FLOWRATE OF 530 GPM. WHEN THE FLOWRATE INCREASES ABOVE 530 GPM MODULATE BYPASS VALVE (HS-1) CLOSED TO MAINTAIN A MINIMUM FLOWRATE OF 530 GPM.

3. WHEEL SYSTEM COOLING TOWER WATER BYPASS WATER CONTROL:

MONITOR COOLING TOWER WATER FLOWRATE WITH FLOW METER (FM2). THE WATER FLOWRATE SETPOINT IS 2,060 GPM. WHEN COOLING TOWER FLOWRATE DROPS BELOW 1,950 GPM MODULATE BYPASS VALVE (HS-2) OPEN TO MAINTAIN A MINIMUM FLOWRATE OF 2,060 GPM. WHEN THE FLOWRATE INCREASES ABOVE 2,165 GPM MODULATE BYPASS VALVE (HS-2) CLOSED TO MAINTAIN A MINIMUM FLOWRATE OF 2,060 GPM. WHEN SYSTEM IS NOT IN OPERATION AND DURING SYSTEM START BYPASS VALVE (HS-2) SHALL FAIL TO THE OPEN POSITION.