

HUSKY PIPING DIAGRAM

KEYNOTES

- 1 CHILLER SUPPLY CHILLED WATER SETPOINT SHALL BE 42 DEGREES F.
- 2 WHEN TAB THE SYSTEM, ADJUST SYSTEM PRESSURE SETPOINT TO LOWEST PRESSURE TO MAINTAIN RELIABLE DESIGN FLOW RATES THRU EQUIPMENT.

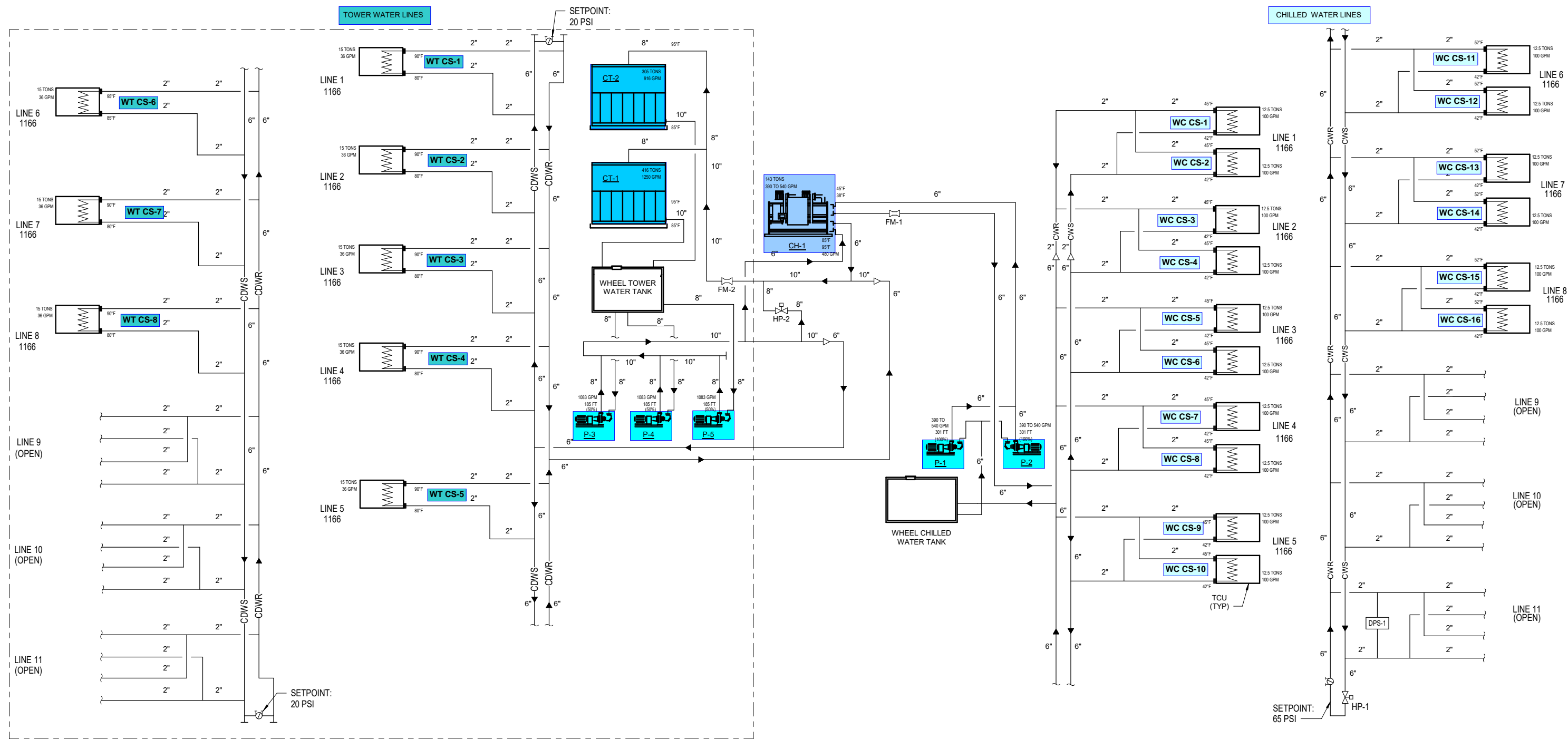

WHEEL PIPING DIAGRAM

SYSTEM SEQUENCE OF OPERATIONS

1. WHEEL SYSTEM CHILLED WATER PUMP (P-1 AND P-2) CONTROL:

ENERGIZE THE LEAD PUMP WHENEVER THE FACILITY EQUIPMENT REQUIRES COOLING. MONITOR PUMP STATUS THRU THE VARIABLE SPEED DRIVE. IF LEAD PUMP FAILS, ALARM TO SYSTEM AND START LAG PUMP. MONITOR CHILLED WATER DIFFERENTIAL PRESSURE, IN THE REMOTE END OF THE PIPING DISTRIBUTION SYSTEM (LOCATION INDICATED) BY DIFFERENTIAL PRESSURE SENSOR (DPS-1). THE PRESSURE SENSOR SHALL BE DIRECT WIRED AND CONNECTED TO THE PUMP SPEED CONTROLLER LOCATED IN THE MECHANICAL ROOM. MODULATE PUMP SPEED THROUGH THE PUMP VARIABLE SPEED CONTROLLER AS REQUIRED TO MAINTAIN SETPOINT (DPS-1). PERIODICALLY EVERY 7 DAYS, CHANGE THE ROLES OF LEAD AND LAG PUMPS.

2. WHEEL SYSTEM MINIMUM CHILLED WATER FLOWRATE:

CHILLED WATER SYSTEM SHALL HAVE TWO FLOWRATE SETPOINT OPTIONS:

- A. OPTION A (NORMAL FLOWRATE OPERATION): 400 GPM SETPOINT.
- B. OPTION B (HIGH FLOWRATE OPERATION): 530 GPM SETPOINT.

PLANT OPERATOR SHALL BE ABLE TO SELECT BETWEEN OPTION A AND B.

- MONITOR CHILLED WATER FLOWRATE WITH FLOW METER (FM1). MODULATE BYPASS VALVE (HS-1) TO MAINTAIN THE MINIMUM FLOWRATE SETPOINT. WHEN SYSTEM IS NOT IN OPERATION AND DURING SYSTEM START BYPASS VALVE (HS-2) SHALL FAIL TO THE OPEN POSITION.
- FOR OPTION A: WHEN CHILLED WATER FLOWRATE DROPS BELOW 400 GPM MODULATE BYPASS VALVE (HS-1) OPEN TO MAINTAIN A MINIMUM FLOWRATE OF 400 GPM. WHEN THE FLOWRATE INCREASES ABOVE 450 GPM MODULATE BYPASS VALVE (HS-1) CLOSED TO MAINTAIN A MINIMUM FLOWRATE OF 400 GPM.
- FOR OPTION B: WHEN CHILLED WATER FLOWRATE DROPS BELOW 470 GPM MODULATE BYPASS VALVE (HS-1) OPEN TO MAINTAIN A MINIMUM FLOWRATE OF 530 GPM. WHEN THE FLOWRATE INCREASES ABOVE 530 GPM MODULATE BYPASS VALVE (HS-1) CLOSED TO MAINTAIN A MINIMUM FLOWRATE OF 530 GPM.

3. WHEEL SYSTEM COOLING TOWER WATER BYPASS WATER CONTROL:

MONITOR COOLING TOWER WATER FLOWRATE WITH FLOW METER (FM2). THE WATER FLOWRATE SETPOINT IS 2,060 GPM. WHEN COOLING TOWER FLOWRATE DROPS BELOW 1,950 GPM MODULATE BYPASS VALVE (HS-2) OPEN TO MAINTAIN A MINIMUM FLOWRATE OF 2,060 GPM. WHEN THE FLOWRATE INCREASES ABOVE 2,165 GPM MODULATE BYPASS VALVE (HS-2) CLOSED TO MAINTAIN A MINIMUM FLOWRATE OF 2,060 GPM. WHEN SYSTEM IS NOT IN OPERATION AND DURING SYSTEM START BYPASS VALVE (HS-2) SHALL FAIL TO THE OPEN POSITION.