SUBMITTAL DATA

Order #: **Date:** 12/09/2023
Project: Sierra - Evansville, IN REV 1
Project #:

Submitter: Alison Trull
UPG National Accounts-York
5005 York Dr.,
Norman, Oklahoma 73069

RTU-1 PAGE 6
RTU-2,3,5 PAGE 19
RTU-4 PAGE 32
RTU-6,7,9 PAGE 45
RTU-8 PAGE 57

EF-1 PAGE 85
EF-2 PAGE 89
EF-3 PAGE 93

Date

12/09/2023

Project Name

Sierra - Evansville, IN REV 1

Project Number**Client / Purchaser**

Submittal Summary Page

Qty	Tag #	Model # / Material #	Description
1	RTU-1	ZJ120N24R4D5HCA1R3	<p>10 Ton, Single Packaged R-410A Air Conditioner, High Efficiency, Two Stage Cooling, 12.0 EER, 240 MBH Input Aluminized Steel, Two Stage Gas Heat, 460-3-60</p> <ul style="list-style-type: none"> • Dry Bulb Low Leak Economizer w/Barometric Relief and Power Exhaust and Hoods (Bottom or Horizontal End Return Only) with Economizer Fault Detection & Diagnostic (Meets ASHRAE 90.1-2013, IECC 2015, California Title 24, AMCA 511). • 3 HP High Static Belt Drive Blower • Standard 2" Throwaway Filters • IntelliSpeed control of the VFD based on stages of cooling (Provides Single Zone VAV Fan Operation as defined by ASHRAE 90.1 section 6.4.3.10) • Smart Equipment Controller including Discharge Air, Return Air, and Outdoor Air Temperature Sensors. BACNet MS/TP, Modbus and N2 Communication Card. • Non-Powered Convenience Outlet • HACR Circuit Breaker/Disconnect • Return Air Smoke Detector (Bottom return only) • Phase Monitor • Micro-Channel "all-aluminum" condenser coil, Copper tube/aluminum fin evaporator coil • Composite Drain Pan - Back Connection • Tool-free maintenance with features like hinged doors for all-access panels, slide-out blower and blower motor tray
1	RTU-1	1RC0471	Roof Curb - 14" High, Flat, Uninsulated, Full Perimeter (Shipped Knocked Down)
1	RTU-1	2EC0401	Kit, Single Enthalpy Field Installed
1	RTU-1	1BD0408	Burglar Bars
1	RTU-1	1HG0411	Hail Guard Kit- Diamond Pattern
3	RTU-2,3,5	ZJ078N18R4D5HCA1R3	<p>6.5 Ton, Single Packaged R-410A Air Conditioner, High Efficiency, Two Stage Cooling, 11.8 EER, 180 MBH Input Aluminized Steel, Two Stage Gas Heat, 460-3-60</p> <ul style="list-style-type: none"> • Dry Bulb Low Leak Economizer w/Barometric Relief and Power Exhaust and Hoods (Bottom or Horizontal End Return Only) with Economizer Fault Detection & Diagnostic (Meets ASHRAE 90.1-2013, IECC 2015, California Title 24, AMCA 511). • 2 HP High Static Belt Drive Blower • Standard 2" Throwaway Filters • IntelliSpeed control of the VFD based on stages of cooling (Provides Single Zone VAV Fan Operation as defined by ASHRAE

Qty	Tag #	Model # / Material #	Description
			90.1 section 6.4.3.10) <ul style="list-style-type: none"> • Smart Equipment Controller including Discharge Air, Return Air, and Outdoor Air Temperature Sensors. BACNet MS/TP, Modbus and N2 Communication Card. • Non-Powered Convenience Outlet • HACR Circuit Breaker/Disconnect • Return Air Smoke Detector (Bottom return only) • Phase Monitor • Micro-Channel "all-aluminum" condenser coil, Copper tube/aluminum fin evaporator coil • Composite Drain Pan - Back Connection • Tool-free maintenance with features like hinged doors for all-access panels, slide-out blower and blower motor tray
3	RTU-2,3,5	1RC0471	Roof Curb - 14" High, Flat, Uninsulated, Full Perimeter (Shipped Knocked Down)
3	RTU-2,3,5	2EC0401	Kit, Single Enthalpy Field Installed
3	RTU-2,3,5	1BD0408	Burglar Bars
3	RTU-2,3,5	1HG0411	Hail Guard Kit- Diamond Pattern
1	RTU-4	ZJ090N18R4D5HCA1R3	7.5 Ton, Single Packaged R-410A Air Conditioner, High Efficiency, Two Stage Cooling, 12.0 EER, 180 MBH Input Aluminized Steel, Two Stage Gas Heat, 460-3-60 <ul style="list-style-type: none"> • Dry Bulb Low Leak Economizer w/Barometric Relief and Power Exhaust and Hoods (Bottom or Horizontal End Return Only) with Economizer Fault Detection & Diagnostic (Meets ASHRAE 90.1-2013, IECC 2015, California Title 24, AMCA 511). • 3 HP High Static Belt Drive Blower • Standard 2" Throwaway Filters • IntelliSpeed control of the VFD based on stages of cooling (Provides Single Zone VAV Fan Operation as defined by ASHRAE 90.1 section 6.4.3.10) • Smart Equipment Controller including Discharge Air, Return Air, and Outdoor Air Temperature Sensors. BACNet MS/TP, Modbus and N2 Communication Card. • Non-Powered Convenience Outlet • HACR Circuit Breaker/Disconnect • Return Air Smoke Detector (Bottom return only) • Phase Monitor • Micro-Channel "all-aluminum" condenser coil, Copper tube/aluminum fin evaporator coil • Composite Drain Pan - Back Connection • Tool-free maintenance with features like hinged doors for all-access panels, slide-out blower and blower motor tray
1	RTU-4	1RC0471	Roof Curb - 14" High, Flat, Uninsulated, Full Perimeter (Shipped Knocked Down)
1	RTU-4	2EC0401	Kit, Single Enthalpy Field Installed
1	RTU-4	1BD0408	Burglar Bars
1	RTU-4	1HG0411	Hail Guard Kit- Diamond Pattern

Qty	Tag #	Model # / Material #	Description
3	RTU-6,7,9	ZT037N08P4B5HCA1R3	<p>3 Ton, Single Packaged R-410A Ultra High Efficiency Air Conditioner, Two Stage Cooling, 80 MBH Input Aluminized Steel, Two Stage Gas Heat, 460-3-60</p> <ul style="list-style-type: none"> • Dry Bulb Low Leak Economizer w/Barometric Relief and Hoods (Bottom or Horizontal End Return Only) with Economizer Fault Detection & Diagnostic (Meets ASHRAE 90.1-2013, IECC 2015, California Title 24, AMCA 511). • VFD Standard • 1.5 HP Standard Static Belt Drive Blower • Standard 2" Throwaway Filters • IntelliSpeed control of the VFD based on stages of cooling (Provides Single Zone VAV Fan Operation as defined by ASHRAE 90.1 section 6.4.3.10) • Smart Equipment Controller including Discharge Air, Return Air, and Outdoor Air Temperature Sensors. BACNet MS/TP, Modbus and N2 Communication Card. • Non-Powered Convenience Outlet • HACR Circuit Breaker/Disconnect • Return Air Smoke Detector (Bottom return only) • Phase Monitor • Micro-Channel "all-aluminum" condenser coil, Copper tube/aluminum fin evaporator coil • Composite Drain Pan - Back Connection • Tool-free maintenance with features like hinged doors for all-access panels, slide-out blower and blower motor tray
3	RTU-6,7,9	1RC0471	Roof Curb - 14" High, Flat, Uninsulated, Full Perimeter (Shipped Knocked Down)
3	RTU-6,7,9	2EC0401	Kit, Single Enthalpy Field Installed
3	RTU-6,7,9	1BD0408	Burglar Bars
3	RTU-6,7,9	1HG0415	Hail Guard Kit- Diamond Pattern
1	RTU-8	ZJ150N24R4D5HCA1R2	<p>12.5 Ton, Single Packaged R-410A Air Conditioner, High Efficiency, Two Stage Cooling, 12.0 EER, 240 MBH Input Aluminized Steel, Two Stage Gas Heat, 460-3-60</p> <ul style="list-style-type: none"> • Dry Bulb Low Leak Economizer w/Barometric Relief and Power Exhaust and Hoods (Bottom or Horizontal End Return Only) with Economizer Fault Detection & Diagnostic (Meets ASHRAE 90.1-2013, IECC 2015, California Title 24, AMCA 511). • 5 HP High Static Belt Drive Blower • Standard 2" Throwaway Filters • IntelliSpeed control of the VFD based on stages of cooling (Provides Single Zone VAV Fan Operation as defined by ASHRAE 90.1 section 6.4.3.10) • Smart Equipment Controller including Discharge Air, Return Air, and Outdoor Air Temperature Sensors. BACNet MS/TP, Modbus and N2 Communication Card. • Non-Powered Convenience Outlet • HACR Circuit Breaker/Disconnect • Return Air Smoke Detector (Bottom return only) • Phase Monitor • Micro-Channel "all-aluminum" condenser coil, Copper

Qty	Tag #	Model # / Material #	Description
			tube/aluminum fin evaporator coil <ul style="list-style-type: none"> • Composite Drain Pan - Back Connection • Tool-free maintenance with features like hinged doors for all-access panels, slide-out blower and blower motor tray
1	RTU-8	1RC0471	Roof Curb - 14" High, Flat, Uninsulated, Full Perimeter (Shipped Knocked Down)
1	RTU-8	2EC0401	Kit, Single Enthalpy Field Installed
1	RTU-8	1BD0408	Burglar Bars
1	RTU-8	1HG0441	Hail Guard Kit- Diamond Pattern
1		FACTORY START UP	FACTORY START UP

Equipment start-up and commissioning by a factory trained technician is recommended.
Contact your supplying distributor or sales representative for additional information & guidance.



WARNING: Cancer and Reproductive Harm - www.P65Warnings.ca.gov

Single Package R-410A Air Conditioner

 Project Name: **Sierra - Evansville, IN REV 1**

 Unit Model #: **ZJ120N24R4D5HCA1R3**

 Quantity: 1 **Tag #: RTU-1**

 System: **ZJ120N24R4D5HCA1R3**

Cooling Performance

Total gross capacity	130.0 MBH
Sensible gross capacity	96.0 MBH
Total net capacity	120.7 MBH
Sensible net capacity	86.7 MBH
Efficiency (at ARI)	12.00 EER
Integrated eff. (at ARI)	15.00 IEER
Ambient DB temp.	95.0 °F
Entering DB temp.	80.0 °F
Entering WB temp.	67.0 °F
Evap Coil Leaving DB temp.	57.8 °F
Evap Coil Leaving WB temp.	56.7 °F
Unit Leaving DB temp.	59.9 °F
Unit Leaving WB temp.	57.5 °F
Leaving air temp dew point	56.00 °F
Power input (w/o blower)	9.00 kW
Sound power	89 dB(a)

Refrigerant

Refrigerant type	R-410A
Sys1	7 lb 12 oz
Sys2	7 lb 10 oz

Gas Heating Performance

Entering DB temp.	60 °F
Heating output capacity (Max)	194.0 MBH
Supply air	4000 cfm
Heating input capacity (Max)	240 MBH
Leaving DB temp.	104.9 °F
Air temp. rise	44.9 °F
SSE	81.0 %
Stages	2

Supply Air Blower Performance

Supply air	4000 cfm
Ext. static pressure	0.6 IWG
Addl. Unit Losses (Options/Accessories)	0.58 IWG
Blower speed	1181 rpm
Max BHP of Motor (including service factor)	3.45 HP
Duct location	Bottom
Motor rating	3.00 HP
Actual required BHP	2.94 HP
Power input	2.74 kW
Elevation	0 ft
Drive type	BELT
Requires field-supplied drive	true

Electrical Data

Power supply	460-3-60
Unit min circuit ampacity	24.3 A
Unit max over-current protection	30 A

Dimensions & Weight

Hgt 51 in	Len 89 in	Wth 59 in
Weight with factory installed options 1355 lb		

Clearances

Right	12 in	Front	48 in	Rear	36 in
Top	72 in	Bottom	0 in	Left	36 in

Note: Please refer to the tech guide for listed maximum static pressures

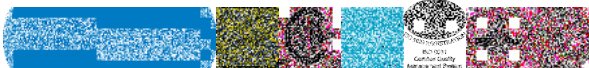

10 Ton

- York Sun Pro units are manufactured at an ISO 9001 registered facility and each rooftop is completely computer-run tested prior to shipment.

Unit Features

- Two Stage Cooling
- 240 MBH Input Aluminized Steel, Two Stage Gas Heat
- Full perimeter base rails with built in rigging capabilities
- Unit Cabinet Constructed of Powder Painted Steel, Certified At 750 Hours Salt Spray Test (ASTM B-117 Standards)
- Dry Bulb Low Leak Economizer w/Barometric Relief and Power Exhaust and Hoods (Bottom or Horizontal End Return Only) with Economizer Fault Detection & Diagnostic (Meets ASHRAE 90.1-2013, IECC 2015, California Title 24, AMCA 511).
- Slide-out Blower/3 HP Belt Drive Motor Assembly
- Solid Core Liquid Line Filter Driers
- Unit Ships with 2" Throwaway Filters
- Replacement Filters: 4 - (24" x 20"). Unit accepts 2" or 4" wide filters.
- Non-Powered Convenience Outlet
- HACR Circuit Breaker/Disconnect
- Single Point Power Connection
- Through-the-Curb and Through-the-Base Utility Connections
- Short Circuit Current: 5kA RMS Symmetrical
- Return Air Smoke Detector
- Micro-Channel "all-aluminum" condenser coil, Copper tube/aluminum fin evaporator coil
- Composite Drain Pan - Back Connection
- Tool-free maintenance with features like hinged doors for all-access panels, slide-out blower and blower motor tray

BAS Controller

- IntelliSpeed control of the VFD based on stages of cooling. Provides Single Zone VAV Fan Operation as defined by ASHRAE 90.1 section 6.4.3.10.
- Smart Equipment Controller including Discharge Air, Return Air, and Outdoor Air Temperature Sensors. BACNet MS/TP, Modbus and N2 communication card.

Standard Unit Controller: Smart Equipment Control Board

- Safety Monitoring - Monitors the High and Low-Pressure Switches, the Freezestats, the Gas Valve, if Applicable, and the Temperature Limit Switch on Gas and Electric Heat Units. The Unit Control Board will Alarm on Ignition Failures, Safety Lockouts and Repeated Limit Switch Trips.

Warranty

- One (1) Year Limited Warranty on the Complete Unit
- Five (5) Year Warranty - Compressors and Electric Heater Elements
- Ten (10) Year Limited Warranty - Aluminized Steel Heat Exchanger



York® Sun™ Pro 3-12.5 Ton Package

Single Package R-410A Air Conditioner

Project Name: **Sierra - Evansville, IN REV 1**

Unit Model #: **ZJ120N24R4D5HCA1R3**

Quantity: **1** Tag #: **RTU-1**

System: **ZJ120N24R4D5HCA1R3**

Additional Electrical Data

Power supply	460-3-60
Unit min circuit ampacity	24.3 A
Unit max over-current protection	30 A
Min Voltage	432 V
Max Voltage	504 V
Comp #1 RLA	6.3
Comp #1 LRA	60.0
Comp #2 RLA	6.3
Comp #2 LRA	60
Indoor Mtr Voltage	460-3-60
Indoor Mtr FLA	4.7
Outdoor Mtr Qty	2
Outdoor Fan Voltage	460-1-60
OD Fan Mtr FLA (ea.)	1.6
Power Ex Mtr Qty (if applicable)	1
Powered Ex Voltage(if applicable)	460-1-60
Power Ex Mtr FLA (ea) (if applicable)	2.2
Combustion Mtr Qty	1
Combustion Motor Voltage	208/230-1-60
Combustion Mtr FLA (ea)	0.5



York® Sun™ Pro 3-12.5 Ton Package

Single Package R-410A Air Conditioner

Project Name: Sierra - Evansville, IN REV 1

Unit Model #: ZJ120N24R4D5HCA1R3

Quantity: 1 Tag #: RTU-1

System: ZJ120N24R4D5HCA1R3

Factory Installed Options

ZJ120N24R4D5HCA1R3

Equipment Options	Option(s) Selected	
Product Category:	ZJ	Single Packaged R-410A Air Conditioner, High Efficiency 12.0 EER
Nominal Cooling Capacity:	120	10 Ton Two Stage Cooling
Heat Type and Nominal Heat Capacity:	N24	240 MBH Input Aluminized Steel, Two Stage Gas Heat
Blower Option:	R	3 HP High Static Belt Drive Blower IntelliSpeed control of the VFD based on stages of cooling (Provides Single Zone VAV Fan Operation as defined by ASHRAE 90.1 section 6.4.3.10)
Voltage:	4	460-3-60
Outside Air Option:	D	Dry Bulb Low Leak Economizer w/Barometric Relief and Power Exhaust and Hoods (Bottom or Horizontal End Return Only) with Economizer Fault Detection & Diagnostic (Meets ASHRAE 90.1-2013, IECC 2015, California Title 24, AMCA 511).
Service Options:	5	Non-Powered Convenience Outlet HACR Circuit Breaker/Disconnect
Sensor Options:	H	Return Air Smoke Detector (Bottom return only)
Controls:	C	Smart Equipment Controller including Discharge Air, Return Air, and Outdoor Air Temperature Sensors. BACNet MS/TP, Modbus and N2 Communication Card.
Refrigeration:	A	Micro-Channel "all-aluminum" condenser coil, Copper tube/aluminum fin evaporator coil
Additional Options:	1	Standard 2" Throwaway Filters Phase Monitor
Cabinet Options:	R	Composite Drain Pan - Back Connection Tool-free maintenance with features like hinged doors for all-access panels, slide-out blower and blower motor tray
Product Generation:	3	

Field Installed Accessories



York® Sun™ Pro 3-12.5 Ton Package

Single Package R-410A Air Conditioner

Project Name: **Sierra - Evansville, IN REV 1**

Unit Model #: **ZJ120N24R4D5HCA1R3**

Quantity: **1** Tag #: **RTU-1**

System: **ZJ120N24R4D5HCA1R3**

- 1RC0471 - Roof Curb - 14" High, Flat, Uninsulated, Full Perimeter (Shipped Knocked Down) (135.0 lbs)
- 2EC0401 - Kit, Single Enthalpy Field Installed (1.0 lbs)
- 1BD0408 - Burglar Bars (32.0 lbs)
- 1HG0411 - Hail Guard Kit-Diamond Pattern (37.0 lbs)

Single Package R-410A Air Conditioner

 Project Name: **Sierra - Evansville, IN**
REV 1

 Unit Model #: **ZJ120N24R4D5HCA1R3**

 Quantity: 1 Tag #: **RTU-1**

Component Locations

Cooling With Gas Heat (6.5 Through 10 Tons)

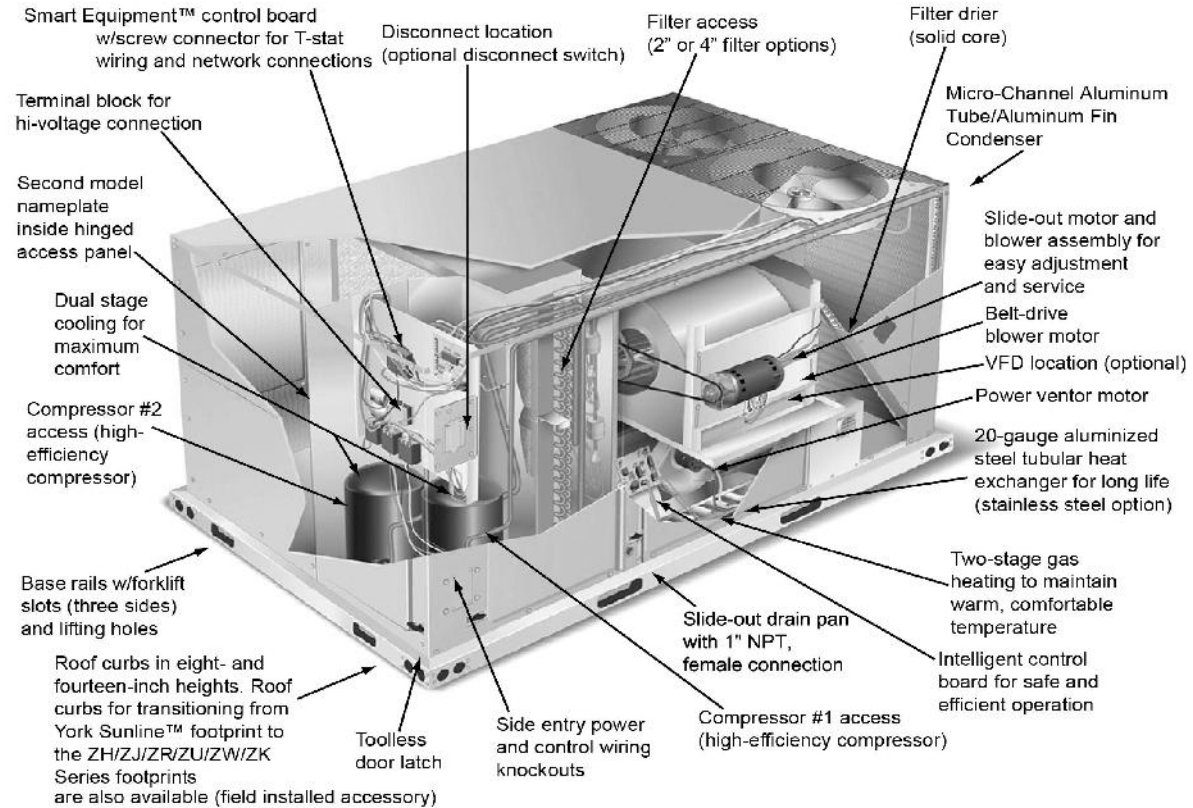

Project Name: **Sierra - Evansville, IN REV 1**

 Unit Model #: **ZJ120N24R4D5HCA1R3**

 Quantity: **1** Tag #: **RTU-1**

Unit Dimensions

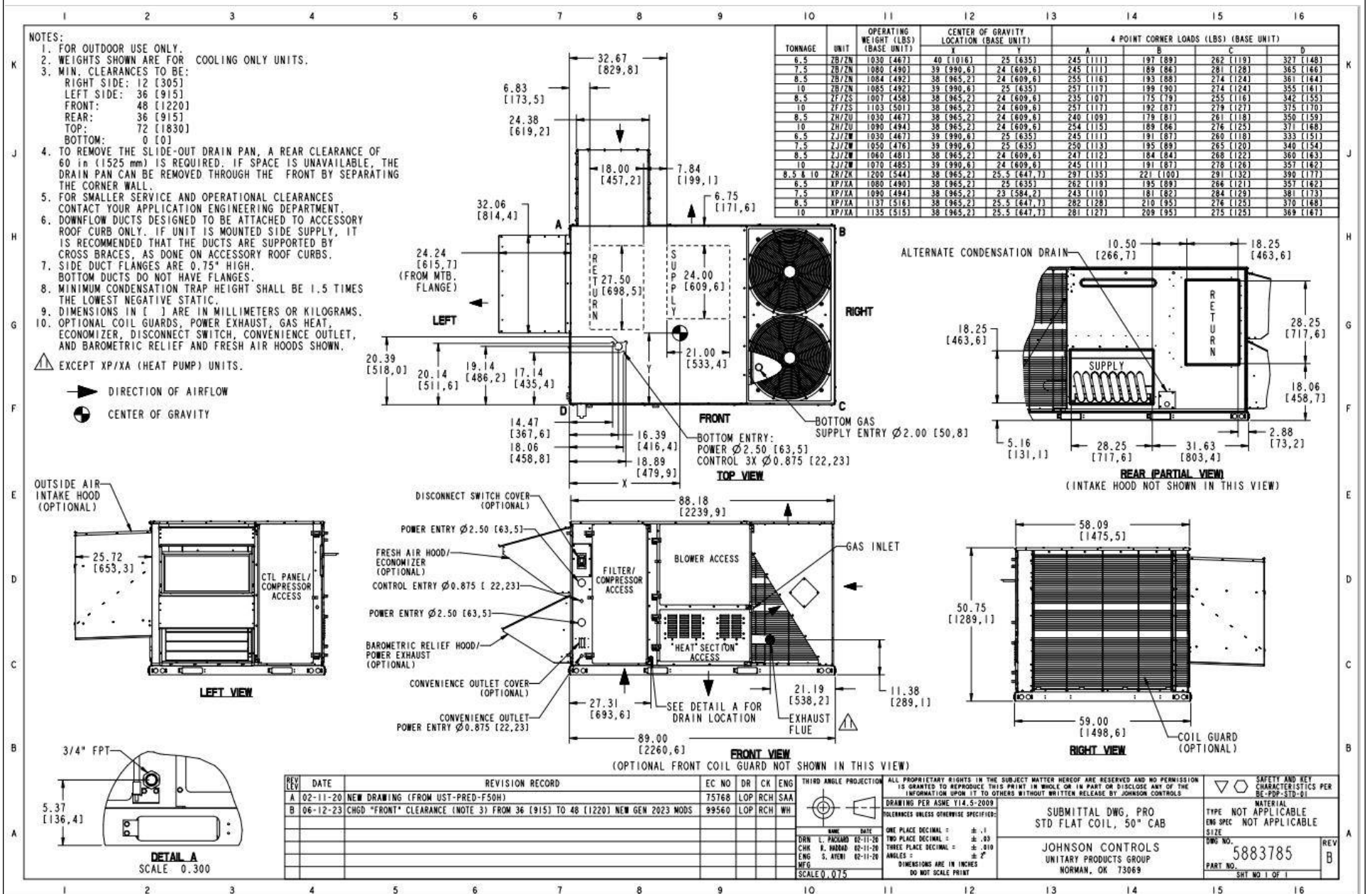

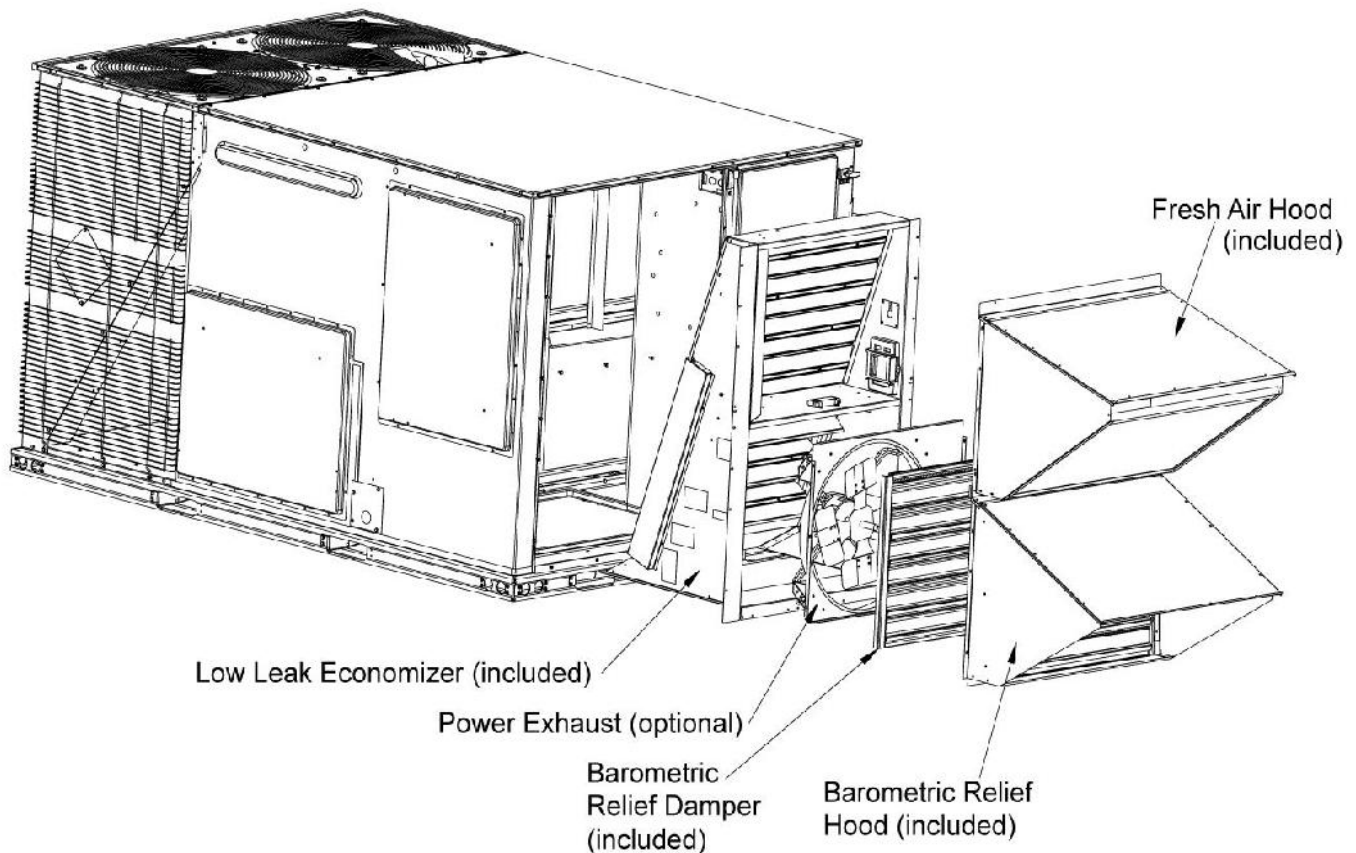
Single Package R-410A Air ConditionerProject Name: **Sierra - Evansville, IN**
REV 1Unit Model #: **ZJ120N24R4D5HCA1R3**Quantity: 1 Tag #: **RTU-1****Low Leak Downflow Economizer****Low Leak Downflow Economizer (shown with optional Power Exhaust)**

Low leak economizers are capable achieving low leakage rates of 3 cfm/sq. ft at 1" of static pressure, meeting or exceeding the following standards:

- ASHRAE 90.1-2010
- ASHRAE 62
- AMCA 511 (licensed as Class 1A damper)
- International Energy Conservation Code (IECC)
- California Title 24

The outdoor intake opening shall be covered with a rain hood that matches the exterior of the unit. Water eliminator/filters shall be provided.

Simultaneous economizer/compressor operation is also possible. Dampers shall fully close on power loss.

Single Package R-410A Air Conditioner

Project Name: **Sierra - Evansville, IN**
REV 1

Unit Model #: **ZJ120N24R4D5HCA1R3**

Quantity: 1 Tag #: **RTU-1**

Factory Installed Power Exhaust

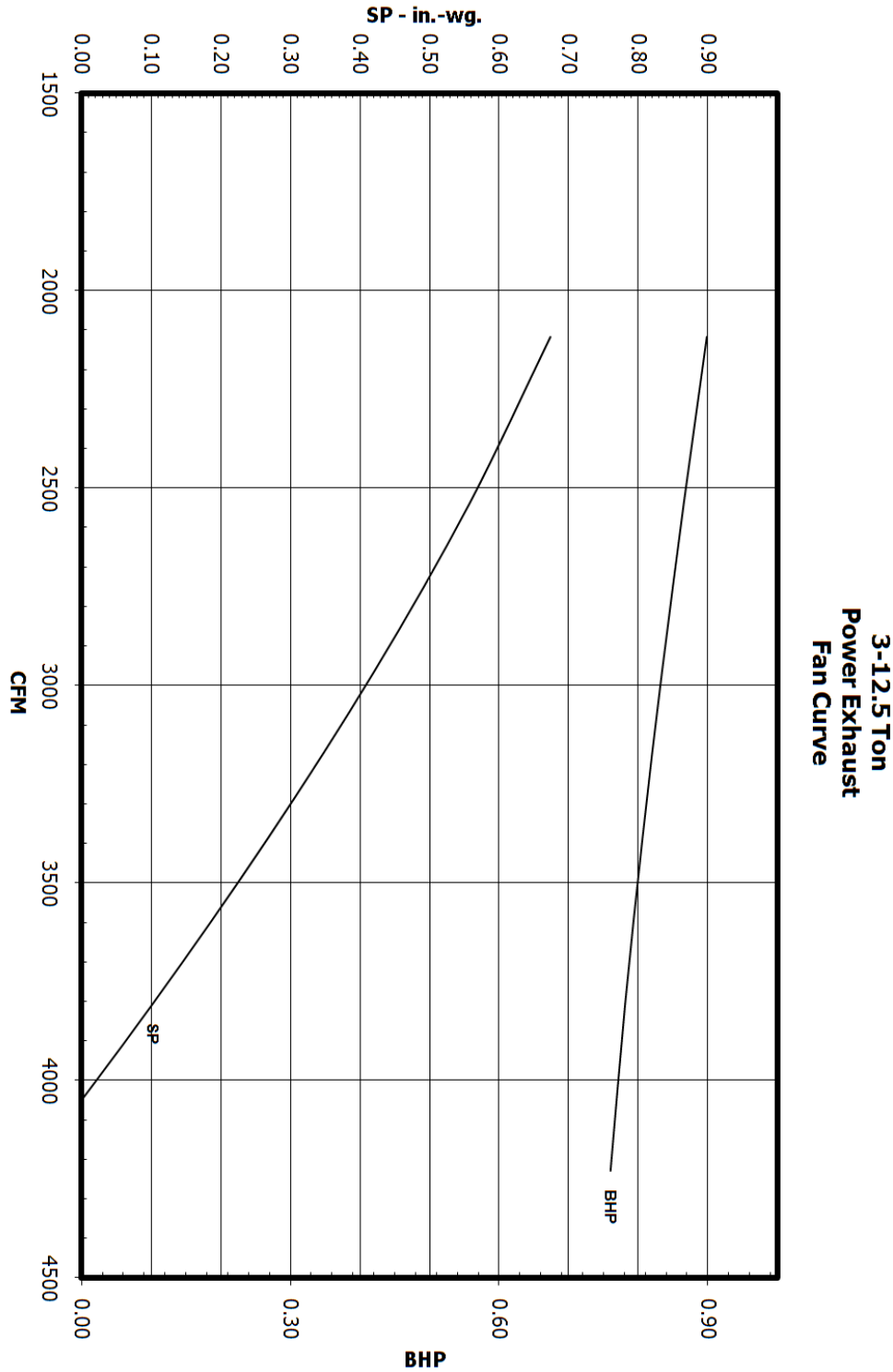

Single Package R-410A Air Conditioner

Project Name: **Sierra - Evansville, IN**
REV 1Unit Model #: **ZJ120N24R4D5HCA1R3**Quantity: 1 Tag #: **RTU-1**

Seismic Certification

**OFFICE OF STATEWIDE HEALTH PLANNING AND DEVELOPMENT
FACILITIES DEVELOPMENT DIVISION**

APPLICATION FOR OSHPD SPECIAL SEISMIC CERTIFICATION PREAPPROVAL (OSP)

OFFICE USE ONLY

APPLICATION #: **OSP - 0213**

OSHPD Special Seismic Certification Preapproval (OSP)

Type: New Renewal

Manufacturer Information

Manufacturer: Johnson Controls Inc. (JCI)Manufacturer's Technical Representative: Cameron Boyce, Engineer IIMailing Address: 5005 Interstate Drive, Norman, OK, 73069Telephone: (405) 419-6830Email: cameron.w.boyce@jci.com

Product Information

Product Name: Predator Rooftop Air Conditioning UnitsProduct Type: Packaged Air Conditioning Units OSP-0213Product Model Number: See attached

(List all unique product identification numbers and/or part numbers)

General Description: The units are enclosures with the following subcomponents: refrigerant compressors, outdoor fan motors, indoor coils, outdoor coils, reversing valve with coil, thermostatic expansion valves, standard indoor blower motor, Variable frequency drive indoor blower motor, exhaust fan motor, variable frequency drive, economizer, electric heater, heat cells, filters, and other miscellaneous items included in the subcomponent tables.Mounting Description: Units are rigid curb and isolated curb base mounted

Applicant Information

Applicant Company Name: The VMC GroupContact Person: John GiulianoMailing Address: 113 Main Street, Bloomingdale, NJ 07403Telephone: (973) 838-1780Email: john.giuliano@thvmcgroup.com

I hereby agree to reimburse the Office of Statewide Health Planning and Development review fees in accordance with the California Administrative Code, 2016.

Signature of Applicant: Date: 8/28/19Title: PresidentCompany Name: The VMC Group*Access to Safe, Quality Healthcare Environments that Meet California's Diverse
STATE OF CALIFORNIA - HEALTH AND HUMAN SERVICES AGENCY
OSH-FD-759 (REV 12/16/15)

Page 1 of 3

Single Package R-410A Air Conditioner

Project Name: **Sierra - Evansville, IN**
REV 1Unit Model #: **ZJ120N24R4D5HCA1R3**Quantity: 1 Tag #: **RTU-1**

Seismic Certification



OFFICE OF STATEWIDE HEALTH PLANNING AND DEVELOPMENT FACILITIES DEVELOPMENT DIVISION

California Licensed Structural Engineer Responsible for the Engineering and Test Report(s)

Company Name: The VMC GroupName: Kenneth Tarlow California License Number: SE-2851Mailing Address: 113 Main Street, Bloomingdale, NJ 07403Telephone: (973) 838-1780 Email: ken.tarlow@thevmcgroup.com

Supports and Attachments Preapproval

- Supports and attachments are preapproved under OPM- _____
(Separate application for OSHPD Preapproval of Manufacturer's Certification (OPM) of Supports and attachments is required)
- Supports and attachments are not preapproved

Certification Method

- Testing in accordance with: ICC-ES AC156
- Other (Please Specify): _____

Testing Laboratory

Company Name: DCL LabsContact Name: Josh Sailer, Laboratory ManagerMailing Address: 1315 Greg Street, Suite 109, Sparks, NV 89431Telephone: (775) 358-5085 Email: josh@shaketest.com

*Access to Safe, Quality Healthcare Environments that Meet California's Diverse

STATE OF CALIFORNIA – HEALTH AND HUMAN SERVICES AGENCY
OSH-FD-759 (REV 12/16/15)

Page 2 of 3

Single Package R-410A Air Conditioner

Project Name: **Sierra - Evansville, IN**
REV 1Unit Model #: **ZJ120N24R4D5HCA1R3**Quantity: 1 Tag #: **RTU-1**

Seismic Certification



OFFICE OF STATEWIDE HEALTH PLANNING AND DEVELOPMENT FACILITIES DEVELOPMENT DIVISION

Seismic Parameters

Design in accordance with ASCE 7-16 Chapter 13: Yes NoDesign Basis of Equipment or Components (F_p/W_p) = Rigid Curb = 1.5; Spring Isolated Curb = 4.5 S_{DS} (Design spectral response acceleration at short period, g) = 2.00 a_p (In-structure equipment or component amplification factor) = 2.5 R_p (Equipment or component response modification factor) = Rigid Curb = 6.0; Spring Isolated Curb = 2.0 Ω_0 (System overstrength factor) = 2.0 I_p (Importance factor) = 1.5 z/h (Height factor ratio) = 1Equipment or Component Natural Frequencies (Hz) = See attachmentOverall dimensions and weight (or range thereof) = See attachmentEquipment or Components @ grade designed in accordance with ASCE 7-16 Chapter 15: Yes NoDesign Basis of Equipment or Components (V/W) = _____ S_{DS} (Design spectral response acceleration at short period, g) = _____ S_{D1} (Design spectral response acceleration at 1 second period, g) = _____ R (Response modification coefficient) = _____ Ω_0 (System overstrength factor) = By: Timothy J Piland C_n (Deflection amplification factor) = _____ I_p (Importance factor) = 1.5

Height to Center of Gravity above base = _____

Equipment or Component Natural Frequencies (Hz) = _____

Overall dimensions and weight (or range thereof) = _____

Tank(s) designed in accordance with ASME BPVC, 2015: Yes No

List of Attachments Supporting Special Seismic Certification

 Test Report(s) Drawings Calculations Manufacturer's Catalog Other(s) (Please Specify): _____

OSHPD Approval (For Office Use Only) – Approval Expires on December 31, 2025

Signature:  Date: March 8, 2021Print Name: Timothy J. Piland Title: SSESpecial Seismic Certification Valid Up to: S_{DS} (g) = 2.00 z/h = 1

Condition of Approval (if applicable): _____

*Access to Safe, Quality Healthcare Environments that Meet California's Diverse

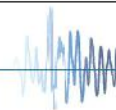
STATE OF CALIFORNIA – HEALTH AND HUMAN SERVICES AGENCY
OSH-FD-759 (REV 12/16/15)

Page 3 of 3

Single Package R-410A Air Conditioner

 Project Name: **Sierra - Evansville, IN**
 REV 1

 Unit Model #: **ZJ120N24R4D5HCA1R3**

Quantity: 1 Tag #: RTU-1

Seismic Certification

Table 1 - Certified Components

Manufacturer: Johnson Controls and other Unitary Product Group brands (York, Coleman, Luxaire, Evcon, Fraser-Johnston and Ready Ship)

Product Line: JCI Packaged Rooftop Units

Product Construction: Cabinet's constructed of G90 galvanized 1,000 hour salt spray (per ASTM B117) rated powder coated 20 gage carbon steel wrapper and duct panel with integral corner posts, all attached at the base to four (4) full perimeter 14 gage base rails with 410 sheet metal screws.

Options: 230-575 V, economizer, power exhaust, electric or gas heater, variable frequency drive

Mounting Description: Rigid or Flexible Curb Mounting

Product Line	Model Number ²	Dimensions (inches)			Operating Weight (lb)	Nominal Cooling Capacity (Tons)	5dK (g), z/h=1	Unit
		Depth	Width	Height				
Precorator Air Handling Units (Short)	ZH/ZU/JA3 037	89	59	42	860 ¹	3	2.0	3
	ZJ/ZW/JA3 037	89	59	42	740	3		Interpolated
	ZR/ZK/JA3 037	89	59	42	980 ¹	3		1
	ZT/ZV/JA3 037	89	59	42	927	3		Interpolated
	ZH/ZU/JA4 049	89	59	42	763	4		Interpolated
	ZJ/ZW/JA4 049	89	59	42	762	4		Interpolated
	ZR/ZK/JA4 049	89	59	42	880	4		Interpolated
	ZT/ZV/JA4 049	89	59	42	960	4		Interpolated
	ZJ/ZW/JA5 061	89	59	42	777	5		Interpolated
	ZJ/ZW/JA5 061	89	59	42	1,070 ¹	5		4
	ZR/ZK/JA5 061	89	59	42	1,070 ¹	5		7
ZT/ZV/JA5 061	89	59	42	968	5	Extrapolated		
Precorator Air Handling Units (Standard)	XF/XA/J06 078	89	59	42	970 ¹	6.5	2.0	7
	ZF/ZS/J06 078	89	59	42	1,090 ¹	6.5		10
	ZH/ZL/J06 078	89	59	42	910	6.5		Interpolated
	ZJ/ZW/J06 078	89	59	51	1,030	6.5		Interpolated
	ZK/ZK/J06 078	89	59	51	1,050 ¹	6.5		5
	ZF/ZS/J07 090	89	59	42	860	7.5		Interpolated
	ZH/ZL/J07 090	89	59	42	910	7.5		Interpolated
	ZJ/ZW/J07 090	89	59	51	1,081	7.5		Interpolated
	XF/XA/J07 090	89	59	42	920	7.5		Interpolated
	ZR/ZK/J07 090	89	59	42	965	7.5		Interpolated
	ZF/ZS/J08 102	89	59	51	1,020	8.5		Interpolated
	ZH/ZL/J08 102	89	59	51	1,030	8.5		Interpolated
	ZJ/ZW/J08 102	89	59	51	1,135	8.5		Interpolated
	ZR/ZK/J08 102	89	59	51	1,200	8.5		Interpolated
	ZF/ZS/J10 120	89	59	51	1,050	10		Interpolated
	ZH/ZL/J10 120	89	59	51	1,090	10		Interpolated
	ZJ/ZW/J10 120	89	59	51	1,070	10		Interpolated
	XF/XA/J10 120	89	59	51	1,135	10		Interpolated
	ZR/ZK/J10 120	89	59	51	1,200	10		Interpolated
	ZF/ZS/J12 150	119.5	59	51	1,253	12.5		Interpolated
	ZH/ZL/J12 150	119.5	59	51	1,250 ¹	12.5		11
XF/XA/J12 150	119.5	59	51	1,510 ¹	12.5	8		
ZJ/ZW/J12 150	119.5	59	51	1,570 ¹	12.5	9		
ZR/ZK/J12 150	119.5	59	51	1,500 ¹	12.5	6		
Precorator Air Handling Units (Ultra High Efficiency)	ZJ/ZV 120	119.5	59	51	1,470 ¹	10	2.0	12
	ZT/ZV 078	119.5	59	51	1,550	6.5		Interpolated
	ZT/ZV 090	119.5	59	51	1,550	7.5		Interpolated
	ZT/ZV 102	119.5	59	51	1,575	8.5		Interpolated
	ZT/ZV 150	119.5	59	51	1,840 ¹	12.5	13	

1. Weights listed for tested units are actual, not approximate weights. The weights listed for interpolated units are maximum weights, assuming all optional features are included. Optional features are summarized in the table below.

2. Model numbers are generalized for each type of unit and the associated BTU tonnage that the unit can output.

Unit Accessory	Operating Weight (lbs.)
Economizer	85
Power Exhaust	35
Electric Heat	49
Gas Heat	110
Variable Frequency Drive	30

1. Weight given is for the maximum electric heater size available.

2. Weight given for the gas heater is for the maximum number of tube heat exchangers available (8 tube).

3. Weight includes mounting hardware, controls and manual bypass option.

Single Package R-410A Air Conditioner

Project Name: **Sierra - Evansville, IN**
REV 1

Unit Model #: **ZJ120N24R4D5HCA1R3**

Quantity: **1** Tag #: **RTU-1**

1RC0471 Roof Curb

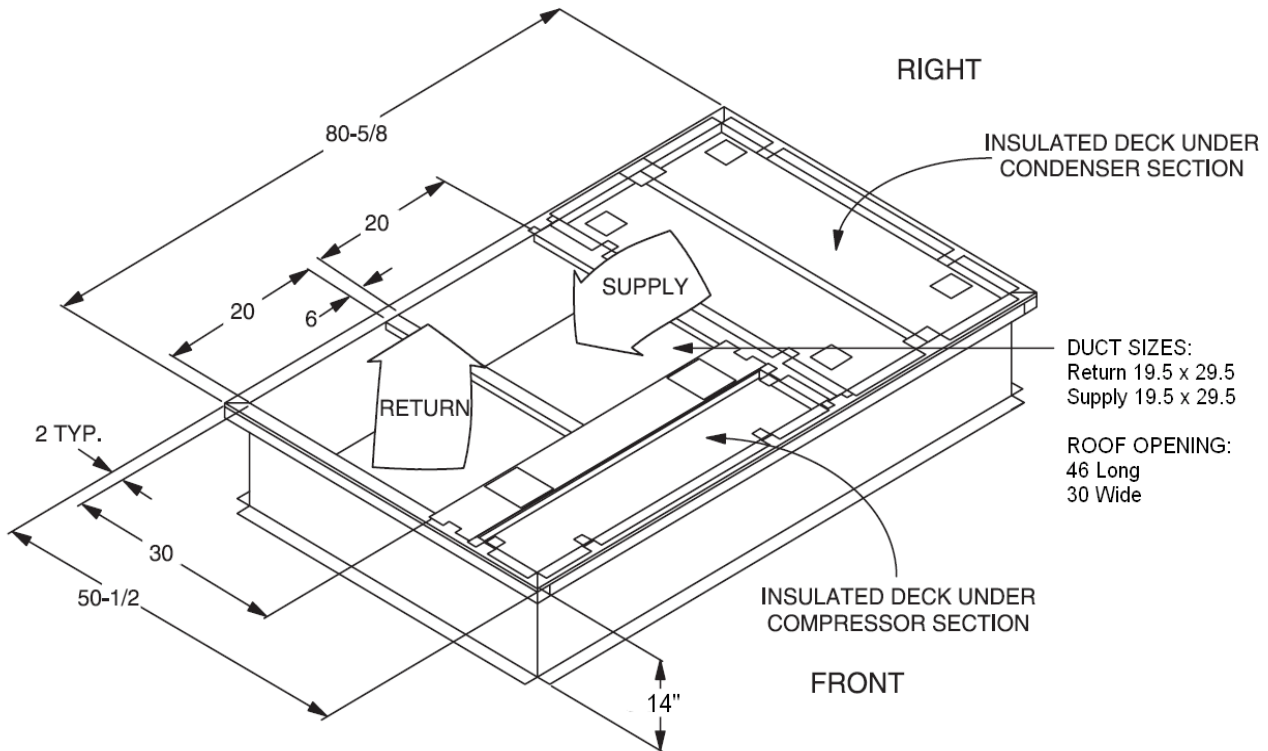

DUCT SIZES:
 Return 19.5 x 29.5
 Supply 19.5 x 29.5

ROOF OPENING:
 46 Long
 30 Wide

* Supply and Return Air (Including duct support rails) as shown, are typical for bottom duct applications.
 For location of horizontal duct applications (On rear of unit), refer to Unit Dimensions details.

1RC0471 Roof Curb Dimensions

Single Package R-410A Air Conditioner

 Project Name: **Sierra - Evansville, IN REV 1**

 Unit Model #: **ZJ078N18R4D5HCA1R3**

 Quantity: **3** Tag #: **RTU-2,3,5**

 System: **ZJ078N18R4D5HCA1R3**

Cooling Performance

Total gross capacity	80.4 MBH
Sensible gross capacity	58.8 MBH
Total net capacity	75.5 MBH
Sensible net capacity	53.9 MBH
Efficiency (at ARI)	11.80 EER
Integrated eff. (at ARI)	15.00 IEER
Ambient DB temp.	95.0 °F
Entering DB temp.	80.0 °F
Entering WB temp.	67.0 °F
Evap Coil Leaving DB temp.	59.1 °F
Evap Coil Leaving WB temp.	57.2 °F
Unit Leaving DB temp.	60.8 °F
Unit Leaving WB temp.	57.9 °F
Leaving air temp dew point	56.00 °F
Power input (w/o blower)	5.90 kW
Sound power	83 dB(a)

Refrigerant

Refrigerant type	R-410A
Sys1	5 lb 12 oz
Sys2	5 lb 12 oz

Gas Heating Performance

Entering DB temp.	60 °F
Heating output capacity (Max)	146.0 MBH
Supply air	2600 cfm
Heating input capacity (Max)	180 MBH
Leaving DB temp.	112.0 °F
Air temp. rise	52.0 °F
SSE	81.0 %
Stages	2

Supply Air Blower Performance

Supply air	2600 cfm
Ext. static pressure	0.8 IWG
Addl. Unit Losses (Options/Accessories)	0.18 IWG
Blower speed	937 rpm
Max BHP of Motor (including service factor)	2.30 HP
Duct location	Bottom
Motor rating	2.00 HP
Actual required BHP	1.54 HP
Power input	1.44 kW
Elevation	0 ft
Drive type	BELT

Electrical Data

Power supply	460-3-60
Unit min circuit ampacity	20.4 A
Unit max over-current protection	25 A

Dimensions & Weight

Hgt 51 in	Len 89 in	Wth 59 in
Weight with factory installed options 1340 lb		

Clearances

Right	12 in	Front	48 in	Rear	36 in
Top	72 in	Bottom	0 in	Left	36 in

Note: Please refer to the tech guide for listed maximum static pressures

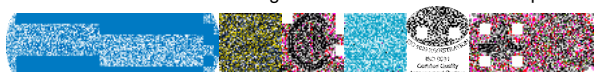

6.5 Ton

- York Sun Pro units are manufactured at an ISO 9001 registered facility and each rooftop is completely computer-run tested prior to shipment.

Unit Features

- Two Stage Cooling
- 180 MBH Input Aluminized Steel, Two Stage Gas Heat
- Full perimeter base rails with built in rigging capabilities
- Unit Cabinet Constructed of Powder Painted Steel, Certified At 750 Hours Salt Spray Test (ASTM B-117 Standards)
- Dry Bulb Low Leak Economizer w/Barometric Relief and Power Exhaust and Hoods (Bottom or Horizontal End Return Only) with Economizer Fault Detection & Diagnostic (Meets ASHRAE 90.1-2013, IECC 2015, California Title 24, AMCA 511).
- 2 HP High Static Belt Drive Blower
- Solid Core Liquid Line Filter Driers
- Unit Ships with 2" Throwaway Filters
- Replacement Filters: 4 - (24" x 20"). Unit accepts 2" or 4" wide filters.
- Non-Powered Convenience Outlet
- HACR Circuit Breaker/Disconnect
- Single Point Power Connection
- Through-the-Curb and Through-the-Base Utility Connections
- Short Circuit Current: 5kA RMS Symmetrical
- Return Air Smoke Detector
- Micro-Channel "all-aluminum" condenser coil, Copper tube/aluminum fin evaporator coil
- Composite Drain Pan - Back Connection
- Tool-free maintenance with features like hinged doors for all-access panels, slide-out blower and blower motor tray

BAS Controller

- IntelliSpeed control of the VFD based on stages of cooling. Provides Single Zone VAV Fan Operation as defined by ASHRAE 90.1 section 6.4.3.10.

Standard Unit Controller: Smart Equipment Control Board

- Safety Monitoring - Monitors the High and Low-Pressure Switches, the Freezestats, the Gas Valve, if Applicable, and the Temperature Limit Switch on Gas and Electric Heat Units. The Unit Control Board will Alarm on Ignition Failures, Safety Lockouts and Repeated Limit Switch Trips.

Warranty

- One (1) Year Limited Warranty on the Complete Unit
- Five (5) Year Warranty - Compressors and Electric Heater Elements
- Ten (10) Year Limited Warranty - Aluminized Steel Heat Exchanger



York® Sun™ Pro 3-12.5 Ton Package

Single Package R-410A Air Conditioner

Project Name: **Sierra - Evansville, IN REV 1**

Unit Model #: **ZJ078N18R4D5HCA1R3**

Quantity: **3** Tag #: **RTU-2,3,5**

System: **ZJ078N18R4D5HCA1R3**

Additional Electrical Data

Power supply	460-3-60
Unit min circuit ampacity	20.4 A
Unit max over-current protection	25 A
Min Voltage	432 V
Max Voltage	504 V
Comp #1 RLA	5.6
Comp #1 LRA	44.0
Comp #2 RLA	5.6
Comp #2 LRA	44
Indoor Mtr Voltage	460-3-60
Indoor Mtr FLA	3.4
Outdoor Mtr Qty	2
Outdoor Fan Voltage	460-1-60
OD Fan Mtr FLA (ea.)	1.1
Power Ex Mtr Qty (if applicable)	1
Powered Ex Voltage(if applicable)	460-1-60
Power Ex Mtr FLA (ea) (if applicable)	2.2
Combustion Mtr Qty	1
Combustion Motor Voltage	208/230-1-60
Combustion Mtr FLA (ea)	0.5



York® Sun™ Pro 3-12.5 Ton Package

Single Package R-410A Air Conditioner

Project Name: **Sierra - Evansville, IN REV 1**

Unit Model #: **ZJ078N18R4D5HCA1R3**

Quantity: **3** Tag #: **RTU-2,3,5**

System: **ZJ078N18R4D5HCA1R3**

Factory Installed Options

ZJ078N18R4D5HCA1R3

Equipment Options	Option(s) Selected
Product Category:	ZJ Single Packaged R-410A Air Conditioner, High Efficiency 11.8 EER
Nominal Cooling Capacity:	078 6.5 Ton Two Stage Cooling
Heat Type and Nominal Heat Capacity:	N18 180 MBH Input Aluminized Steel, Two Stage Gas Heat
Blower Option:	R 2 HP High Static Belt Drive Blower IntelliSpeed control of the VFD based on stages of cooling (Provides Single Zone VAV Fan Operation as defined by ASHRAE 90.1 section 6.4.3.10)
Voltage:	4 460-3-60
Outside Air Option:	D Dry Bulb Low Leak Economizer w/Barometric Relief and Power Exhaust and Hoods (Bottom or Horizontal End Return Only) with Economizer Fault Detection & Diagnostic (Meets ASHRAE 90.1-2013, IECC 2015, California Title 24, AMCA 511).
Service Options:	5 Non-Powered Convenience Outlet HACR Circuit Breaker/Disconnect
Sensor Options:	H Return Air Smoke Detector (Bottom return only)
Controls:	C Smart Equipment Controller including Discharge Air, Return Air, and Outdoor Air Temperature Sensors. BACNet MS/TP, Modbus and N2 Communication Card.
Refrigeration:	A Micro-Channel "all-aluminum" condenser coil, Copper tube/aluminum fin evaporator coil
Additional Options:	1 Standard 2" Throwaway Filters Phase Monitor
Cabinet Options:	R Composite Drain Pan - Back Connection Tool-free maintenance with features like hinged doors for all-access panels, slide-out blower and blower motor tray
Product Generation:	3

Field Installed Accessories



York® Sun™ Pro 3-12.5 Ton Package

Single Package R-410A Air Conditioner

Project Name: **Sierra - Evansville, IN REV 1**

Unit Model #: **ZJ078N18R4D5HCA1R3**

Quantity: **3** Tag #: **RTU-2,3,5**

System: **ZJ078N18R4D5HCA1R3**

- 1RC0471 - Roof Curb - 14" High, Flat, Uninsulated, Full Perimeter (Shipped Knocked Down) (135.0 lbs)
- 2EC0401 - Kit, Single Enthalpy Field Installed (1.0 lbs)
- 1BD0408 - Burglar Bars (32.0 lbs)
- 1HG0411 - Hail Guard Kit-Diamond Pattern (37.0 lbs)

Single Package R-410A Air Conditioner

Project Name: **Sierra - Evansville, IN**
REV 1

Unit Model #: **ZJ078N18R4D5HCA1R3**

Quantity: **3** Tag #: **RTU-2,3,5**

Component Locations

Cooling With Gas Heat (6.5 Through 10 Tons)

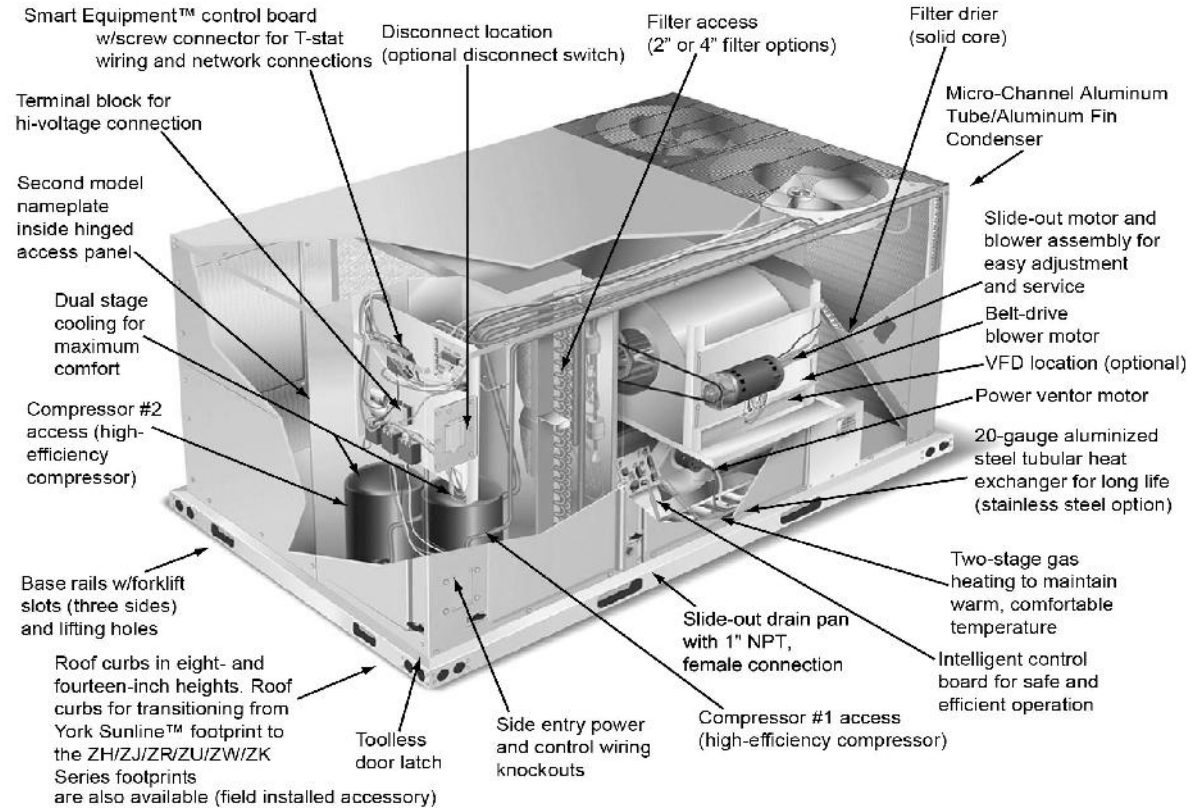

Project Name: **Sierra - Evansville, IN REV 1**

 Unit Model #: **ZJ078N18R4D5HCA1R3**

 Quantity: **3** Tag #: **RTU-2,3,5**

Unit Dimensions

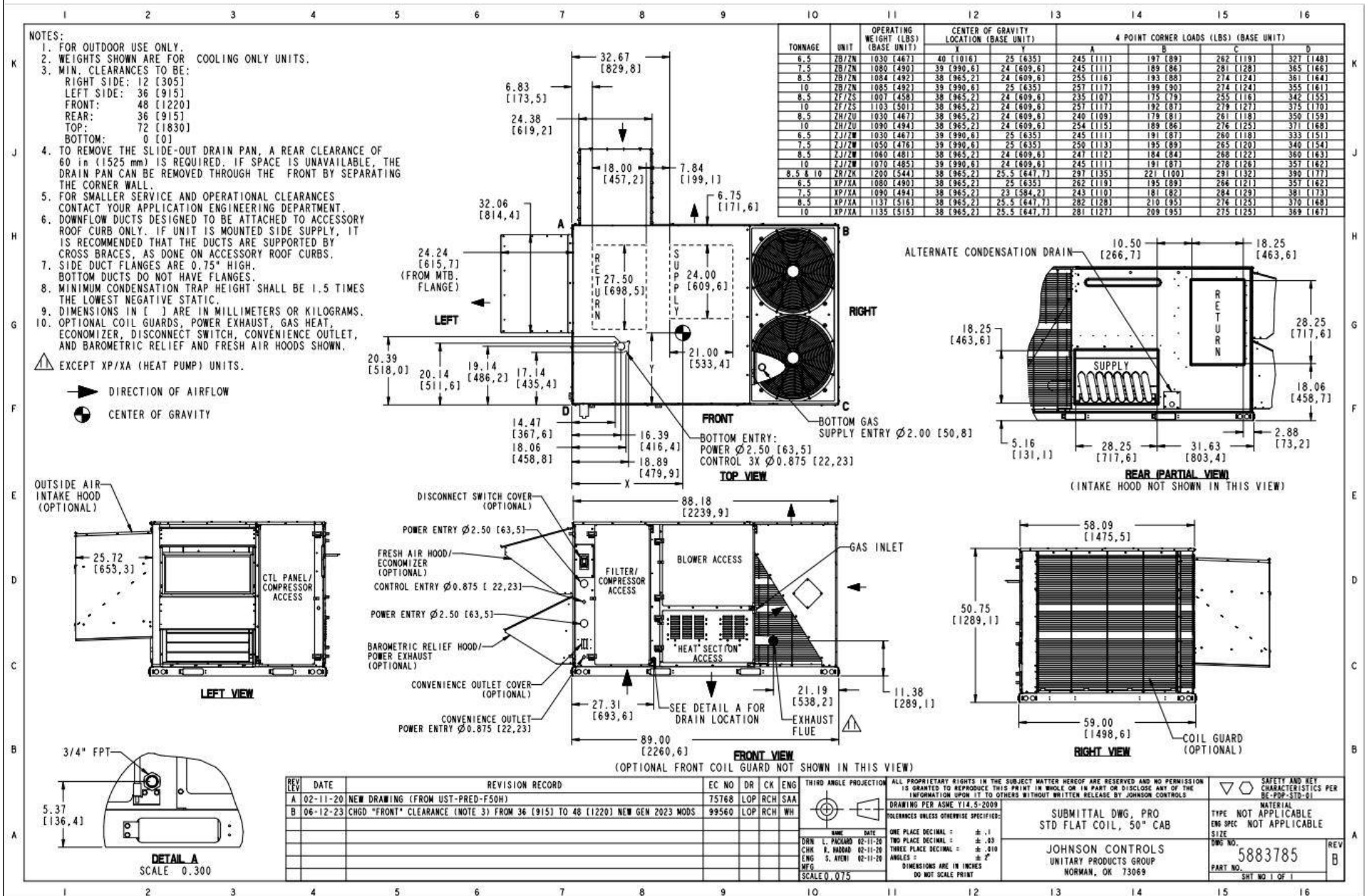

Single Package R-410A Air Conditioner

Project Name: **Sierra - Evansville, IN**
REV 1

Unit Model #: **ZJ078N18R4D5HCA1R3**

Quantity: **3** Tag #: **RTU-2,3,5**

Low Leak Downflow Economizer

Low Leak Downflow Economizer (shown with optional Power Exhaust)

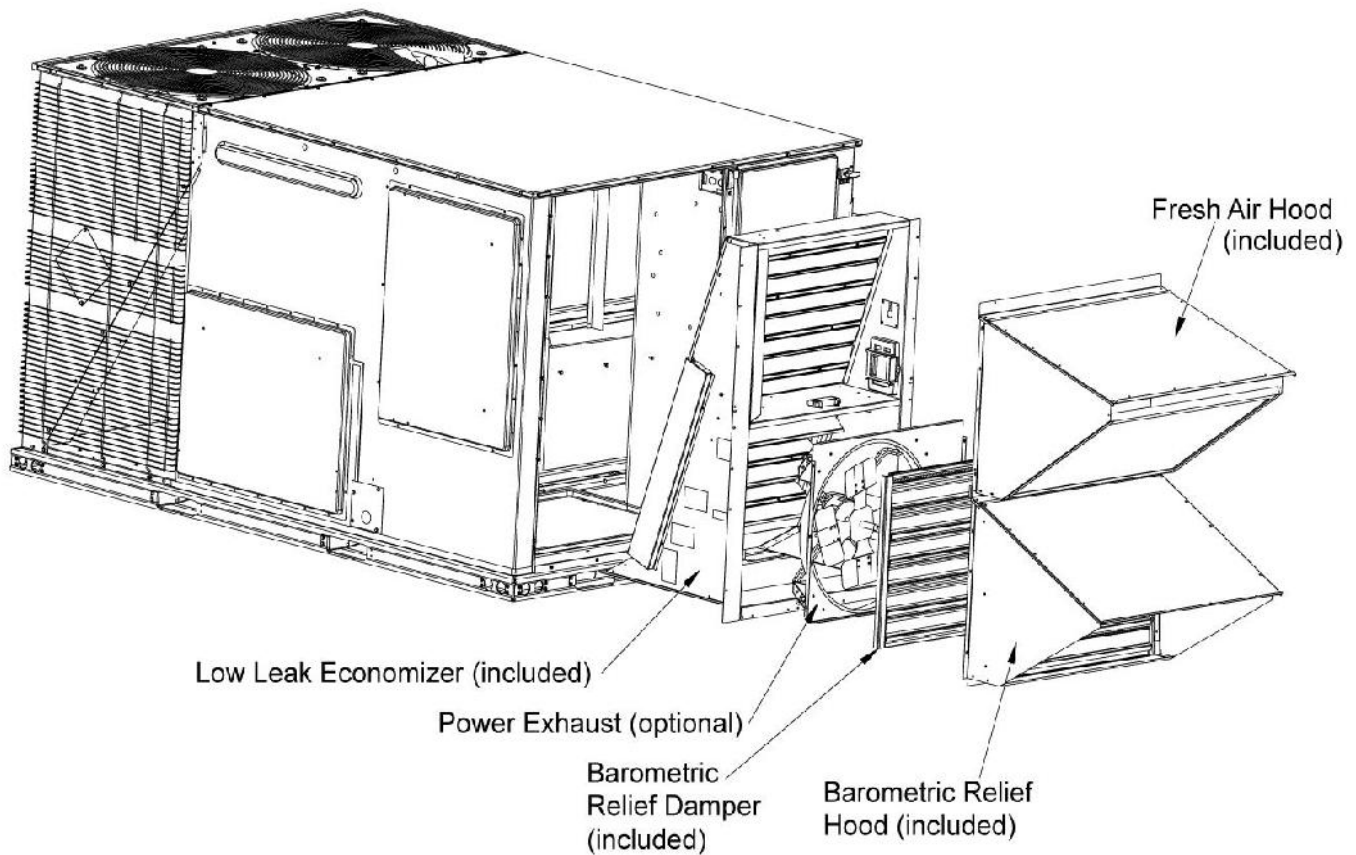

Low leak economizers are capable achieving low leakage rates of 3 cfm/sq. ft at 1" of static pressure, meeting or exceeding the following standards:

- ASHRAE 90.1-2010
- ASHRAE 62
- AMCA 511 (licensed as Class 1A damper)
- International Energy Conservation Code (IECC)
- California Title 24

The outdoor intake opening shall be covered with a rain hood that matches the exterior of the unit. Water eliminator/filters shall be provided.

Simultaneous economizer/compressor operation is also possible. Dampers shall fully close on power loss.

Single Package R-410A Air Conditioner

Project Name: **Sierra - Evansville, IN**
REV 1

Unit Model #: **ZJ078N18R4D5HCA1R3**

Quantity: **3** Tag #: **RTU-2,3,5**

Factory Installed Power Exhaust

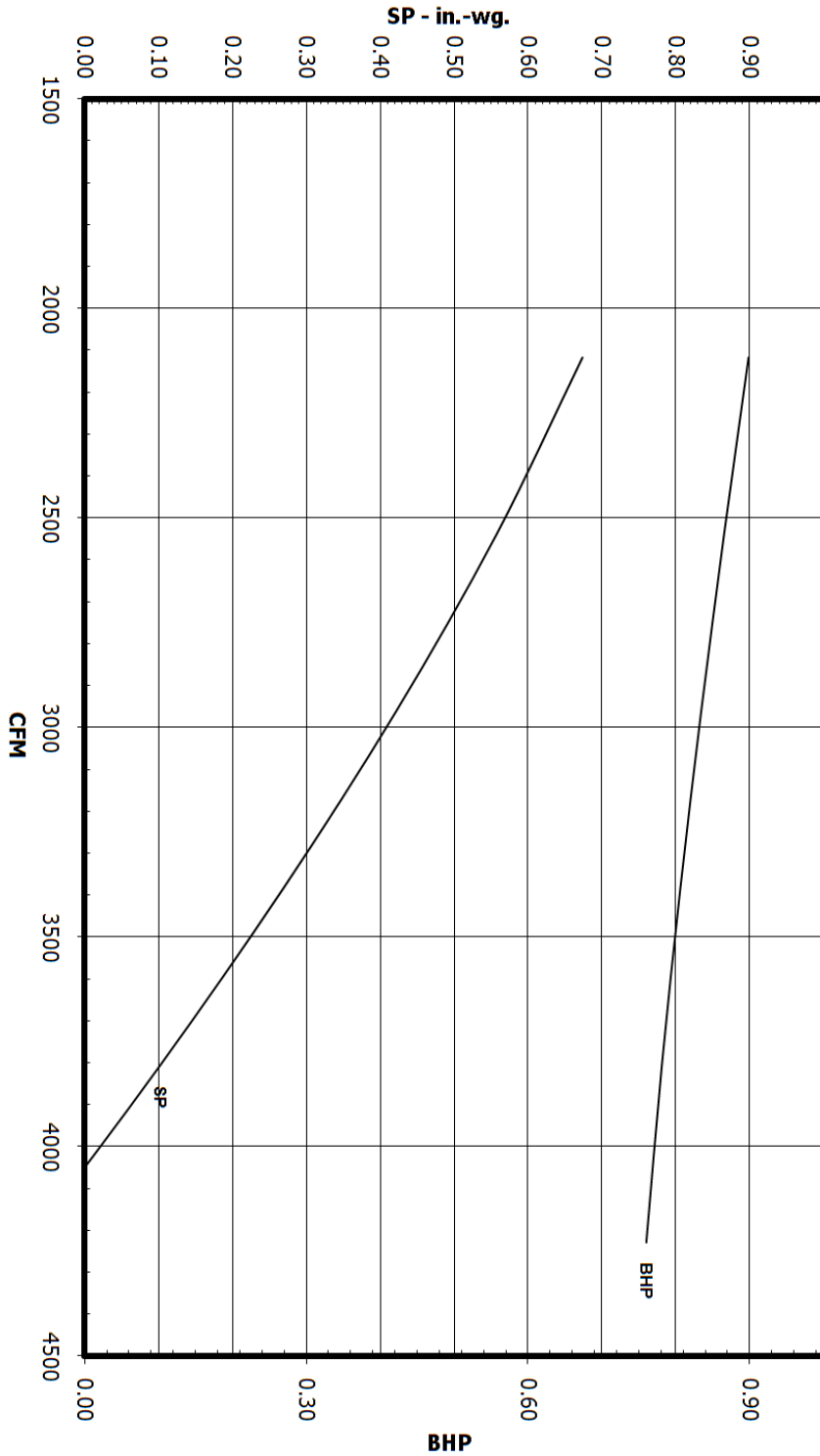

**3-12.5 Ton
 Power Exhaust
 Fan Curve**

Single Package R-410A Air Conditioner

Project Name: **Sierra - Evansville, IN**
REV 1Unit Model #: **ZJ078N18R4D5HCA1R3**Quantity: **3** Tag #: **RTU-2,3,5**

Seismic Certification



OFFICE OF STATEWIDE HEALTH PLANNING AND DEVELOPMENT FACILITIES DEVELOPMENT DIVISION

APPLICATION FOR OSHPD SPECIAL SEISMIC CERTIFICATION PREAPPROVAL (OSP)

OFFICE USE ONLY

APPLICATION #: **OSP - 0213**

OSHPD Special Seismic Certification Preapproval (OSP)

Type: New Renewal

Manufacturer Information

Manufacturer: Johnson Controls Inc. (JCI)Manufacturer's Technical Representative: Cameron Boyce, Engineer IIMailing Address: 5005 Interstate Drive, Norman, OK, 73069Telephone: (405) 419-6830Email: cameron.w.boyce@jci.com

Product Information

Product Name: Predator Rooftop Air Conditioning UnitsProduct Type: Packaged Air Conditioning Units OSP-0213Product Model Number: See attached

(List all unique product identification numbers and/or part numbers)

The units are enclosures with the following subcomponents: refrigerant compressors, outdoor fan motors, indoor coils, outdoor coils, reversing valve with coil, thermostatic expansion valves, standard indoor blower motor, Variable frequency drive indoor blower motor, exhaust fan motor, variable frequency drive, economizer, electric heater, heat cells, filters, and other miscellaneous items included in the subcomponent tables.

Mounting Description: Units are rigid curb and isolated curb base mounted

Applicant Information

Applicant Company Name: The VMC GroupContact Person: John GiulianoMailing Address: 113 Main Street, Bloomingdale, NJ 07403Telephone: (973) 838-1780Email: john.giuliano@thvmcgroup.com

I hereby agree to reimburse the Office of Statewide Health Planning and Development review fees in accordance with the California Administrative Code, 2016.

Signature of Applicant: Date: 8/28/19Title: PresidentCompany Name: The VMC Group

*Access to Safe, Quality Healthcare Environments that Meet California's Diverse
STATE OF CALIFORNIA - HEALTH AND HUMAN SERVICES AGENCY
OSH-FD-759 (REV 12/16/15)



Page 1 of 3

Single Package R-410A Air Conditioner

Project Name: **Sierra - Evansville, IN**
REV 1Unit Model #: **ZJ078N18R4D5HCA1R3**Quantity: **3** Tag #: **RTU-2,3,5**

Seismic Certification



OFFICE OF STATEWIDE HEALTH PLANNING AND DEVELOPMENT FACILITIES DEVELOPMENT DIVISION

California Licensed Structural Engineer Responsible for the Engineering and Test Report(s)

Company Name: The VMC GroupName: Kenneth Tarlow California License Number: SE-2851Mailing Address: 113 Main Street, Bloomingdale, NJ 07403Telephone: (973) 838-1780 Email: ken.tarlow@thevmcgroup.com

Supports and Attachments Preapproval

- Supports and attachments are preapproved under OPM- _____
(Separate application for OSHPD Preapproval of Manufacturer's Certification (OPM) of Supports and attachments is required)
- Supports and attachments are not preapproved

Certification Method

- Testing in accordance with: ICC-ES AC156
- Other (Please Specify): _____

BY: Timothy J Piland

DATE: 03/08/2021

Testing Laboratory

Company Name: DCL LabsContact Name: Josh Sailer, Laboratory ManagerMailing Address: 1315 Greg Street, Suite 109, Sparks, NV 89431Telephone: (775) 358-5085 Email: josh@shaketest.com

*Access to Safe, Quality Healthcare Environments that Meet California's Diverse

STATE OF CALIFORNIA – HEALTH AND HUMAN SERVICES AGENCY
OSH-FD-759 (REV 12/16/15)

Page 2 of 3

Single Package R-410A Air Conditioner

Project Name: **Sierra - Evansville, IN**
REV 1Unit Model #: **ZJ078N18R4D5HCA1R3**Quantity: **3** Tag #: **RTU-2,3,5**

Seismic Certification



OFFICE OF STATEWIDE HEALTH PLANNING AND DEVELOPMENT FACILITIES DEVELOPMENT DIVISION

Seismic Parameters

Design in accordance with ASCE 7-16 Chapter 13: Yes NoDesign Basis of Equipment or Components (F_p/W_p) = Rigid Curb = 1.5; Spring Isolated Curb = 4.5 S_{DS} (Design spectral response acceleration at short period, g) = 2.00 a_p (In-structure equipment or component amplification factor) = 2.5 R_p (Equipment or component response modification factor) = Rigid Curb = 6.0; Spring Isolated Curb = 2.0 Ω_0 (System overstrength factor) = 2.0 I_p (Importance factor) = 1.5 z/h (Height factor ratio) = 1Equipment or Component Natural Frequencies (Hz) = See attachmentOverall dimensions and weight (or range thereof) = See attachmentEquipment or Components @ grade designed in accordance with ASCE 7-16 Chapter 15: Yes NoDesign Basis of Equipment or Components (V/W) = _____ S_{DS} (Design spectral response acceleration at short period, g) = _____ S_{D1} (Design spectral response acceleration at 1 second period, g) = _____ R (Response modification coefficient) = _____ Ω_0 (System overstrength factor) = By: Timothy J Piland C_d (Deflection amplification factor) = _____ I_p (Importance factor) = 1.5

Height to Center of Gravity above base = _____

Equipment or Component Natural Frequencies (Hz) = _____

Overall dimensions and weight (or range thereof) = _____

Tank(s) designed in accordance with ASME BPVC, 2015: Yes No

List of Attachments Supporting Special Seismic Certification

 Test Report(s) Drawings Calculations Manufacturer's Catalog Other(s) (Please Specify): _____

OSHPD Approval (For Office Use Only) – Approval Expires on December 31, 2025

Signature:  Date: March 8, 2021Print Name: Timothy J. Piland Title: SSESpecial Seismic Certification Valid Up to: S_{DS} (g) = 2.00 z/h = 1

Condition of Approval (if applicable): _____

*Access to Safe, Quality Healthcare Environments that Meet California's Diverse

STATE OF CALIFORNIA – HEALTH AND HUMAN SERVICES AGENCY
OSH-FD-759 (REV 12/16/15)

Page 3 of 3

Single Package R-410A Air Conditioner

 Project Name: **Sierra - Evansville, IN**
 REV 1

 Unit Model #: **ZJ078N18R4D5HCA1R3**

 Quantity: **3** Tag #: **RTU-2,3,5**

Seismic Certification

Table 1 - Certified Components

Manufacturer: Johnson Controls and other Unitary Product Group brands (York, Coleman, Luxaire, Evcon, Fraser-Johnston and Ready Ship)

Product Line: JCI Packaged Rooftop Units

Product Construction: Cabinet's constructed of G90 galvanized 1,000 hour salt spray (per ASTM B117) rated powder coated 20 gage carbon steel wrapper and duct panel with integral corner posts, all attached at the base to four (4) full perimeter 14 gage base rails with 410 sheet metal screws.

Options: 230-575 V, economizer, power exhaust, electric or gas heater, variable frequency drive

Mounting Description: Rigid or Flexible Curb Mounting

Product Line	Model Number ²	Dimensions (inches)			Operating Weight (lb)	Nominal Cooling Capacity (Tons)	5dK (g), z/h=1	Unit
		Depth	Width	Height				
Precorator Air Handling Units (Short)	ZH/ZU/JA3 037	89	59	42	860 ¹	3	2.0	3
	ZJ/ZW/JA3 037	89	59	42	740	3		Interpolated
	ZR/ZK/JA3 037	89	59	42	980 ¹	3		1
	ZT/ZV/JA3 037	89	59	42	927	3		Interpolated
	ZH/ZU/JA4 049	89	59	42	763	4		Interpolated
	ZJ/ZW/JA4 049	89	59	42	762	4		Interpolated
	ZR/ZK/JA4 049	89	59	42	880	4		Interpolated
	ZT/ZV/JA4 049	89	59	42	960	4		Interpolated
	ZI/ZV/JA5 061	89	59	42	777	5		Interpolated
	ZJ/ZW/JA5 061	89	59	42	1,070 ¹	5		4
	ZR/ZK/JA5 061	89	59	42	1,070 ¹	5		7
	ZT/ZV/JA5 061	89	59	42	968	5		Extrapolated
Precorator Air Handling Units (Standard)	XF/XA/J06 078	89	59	42	970 ¹	6.5	2.0	7
	ZF/ZS/J06 078	89	59	42	1,090 ¹	6.5		10
	ZH/ZL/J06 078	89	59	42	910	6.5		Interpolated
	ZI/ZV/J06 078	89	59	51	1,030	6.5		Interpolated
	ZJ/ZW/J06 078	89	59	51	1,050 ¹	6.5		5
	ZR/ZK/J06 078	89	59	42	860	7.5		Interpolated
	ZT/ZV/J06 078	89	59	42	910	7.5		Interpolated
	ZI/ZW/J07 090	89	59	51	1,081	7.5		Interpolated
	XF/XA/J07 090	89	59	42	920	7.5		Interpolated
	ZR/ZK/J07 090	89	59	42	965	7.5		Interpolated
	ZF/ZS/J08 102	89	59	51	1,020	8.5		Interpolated
	ZH/ZL/J08 102	89	59	51	1,030	8.5		Interpolated
	ZI/ZV/J08 102	89	59	51	1,135	8.5		Interpolated
	ZJ/ZW/J08 102	89	59	51	1,200	8.5		Interpolated
	ZR/ZK/J08 102	89	59	51	1,200	8.5		Interpolated
	ZF/ZS/J10 120	89	59	51	1,050	10		Interpolated
	ZH/ZL/J10 120	89	59	51	1,090	10		Interpolated
	ZI/ZV/J10 120	89	59	51	1,070	10		Interpolated
	ZJ/ZW/J10 120	89	59	51	1,135	10		Interpolated
	ZR/ZK/J10 120	89	59	51	1,200	10		Interpolated
	ZT/ZV/J12 150	119.5	59	51	1,253	12.5		Interpolated
	ZH/ZL/J12 150	119.5	59	51	1,250 ¹	12.5		11
	XF/XA/J12 150	119.5	59	51	1,510 ¹	12.5		8
	ZI/ZV/J12 150	119.5	59	51	1,570 ¹	12.5		9
ZR/ZK/J12 150	119.5	59	51	1,500 ¹	12.5	6		
Precorator Air Handling Units (Ultra High Efficiency)	ZI/ZV 120	119.5	59	51	1,470 ¹	10	2.0	12
	ZT/ZV 078	119.5	59	51	1,550	6.5		Interpolated
	ZT/ZV 090	119.5	59	51	1,550	7.5		Interpolated
	ZT/ZV 102	119.5	59	51	1,575	8.5		Interpolated
	ZT/ZV 150	119.5	59	51	1,880 ¹	12.5	13	

1. Weights listed for tested units are actual, not approximate weights. The weights listed for interpolated units are maximum weights, assuming all optional features are included. Optional features are summarized in the table below.

2. Model numbers are generalized for each type of unit and the associated BTU tonnage that the unit can output.

Unit Accessory	Operating Weight (lbs.)
Economizer	85
Power Exhaust	35
Electric Heat	49
Gas Heat	110
Variable Frequency Drive	30

1. Weight given is for the maximum electric heater size available.

2. Weight given for the gas heater is for the maximum number of tube heat exchangers available (8 tube).

3. Weight includes mounting hardware, controls and manual bypass option.

Single Package R-410A Air Conditioner

Project Name: **Sierra - Evansville, IN**
REV 1

Unit Model #: **ZJ078N18R4D5HCA1R3**

Quantity: **3** Tag #: **RTU-2,3,5**

1RC0471 Roof Curb

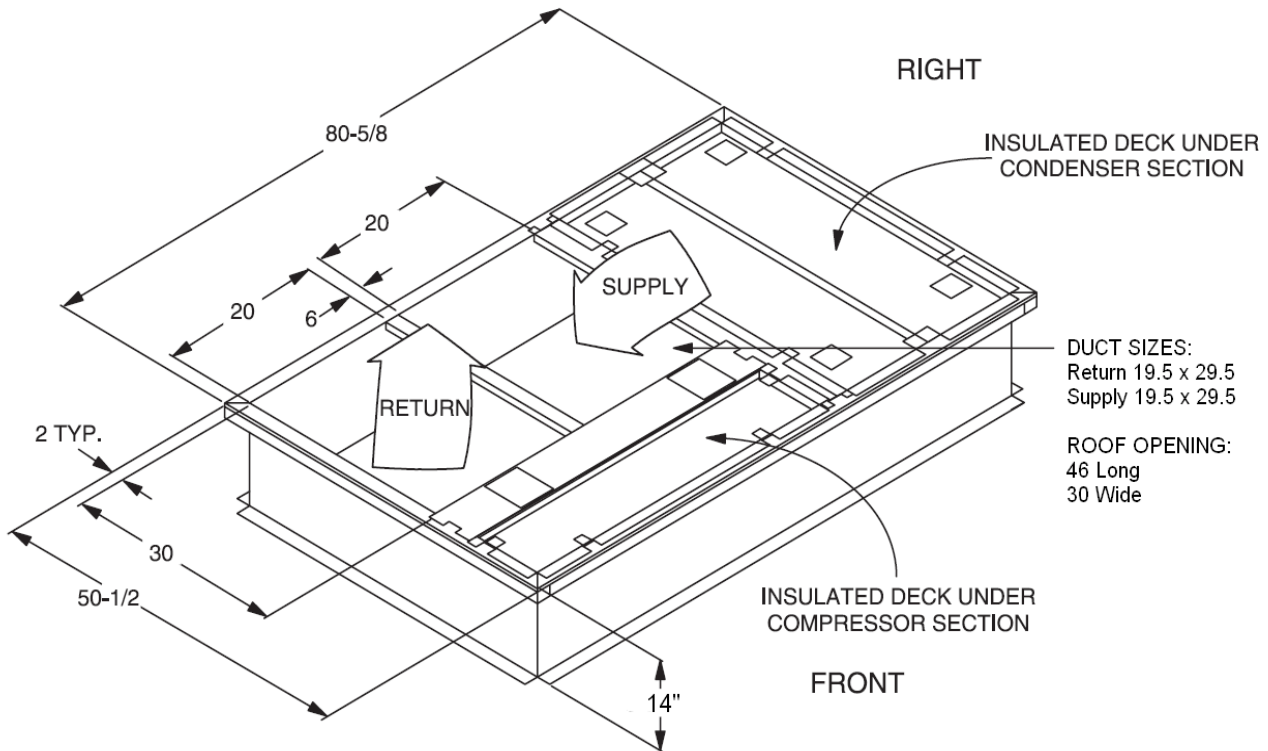

DUCT SIZES:
 Return 19.5 x 29.5
 Supply 19.5 x 29.5
 ROOF OPENING:
 46 Long
 30 Wide

* Supply and Return Air (Including duct support rails) as shown, are typical for bottom duct applications.
 For location of horizontal duct applications (On rear of unit), refer to Unit Dimensions details.

1RC0471 Roof Curb Dimensions

Single Package R-410A Air Conditioner

 Project Name: **Sierra - Evansville, IN REV 1**

 Unit Model #: **ZJ090N18R4D5HCA1R3**

 Quantity: **1** Tag #: **RTU-4**

 System: **ZJ090N18R4D5HCA1R3**

Cooling Performance

Total gross capacity	94.3 MBH
Sensible gross capacity	71.0 MBH
Total net capacity	88.2 MBH
Sensible net capacity	64.9 MBH
Efficiency (at ARI)	12.00 EER
Integrated eff. (at ARI)	14.60 IEER
Ambient DB temp.	95.0 °F
Entering DB temp.	80.0 °F
Entering WB temp.	67.0 °F
Evap Coil Leaving DB temp.	58.1 °F
Evap Coil Leaving WB temp.	57.0 °F
Unit Leaving DB temp.	60.0 °F
Unit Leaving WB temp.	57.7 °F
Leaving air temp dew point	56.30 °F
Power input (w/o blower)	6.30 kW
Sound power	86 dB(a)

Refrigerant

Refrigerant type	R-410A
Sys1	6 lb 4 oz
Sys2	6 lb 7 oz

Gas Heating Performance

Entering DB temp.	60 °F
Heating output capacity (Max)	146.0 MBH
Supply air	3000 cfm
Heating input capacity (Max)	180 MBH
Leaving DB temp.	105.1 °F
Air temp. rise	45.1 °F
SSE	81.0 %
Stages	2

Supply Air Blower Performance

Supply air	3000 cfm
Ext. static pressure	0.8 IWG
Addl. Unit Losses (Options/Accessories)	0.31 IWG
Blower speed	967 rpm
Max BHP of Motor (including service factor)	3.45 HP
Duct location	Bottom
Motor rating	3.00 HP
Actual required BHP	1.91 HP
Power input	1.78 kW
Elevation	0 ft
Drive type	BELT

Electrical Data

Power supply	460-3-60
Unit min circuit ampacity	23.8 A
Unit max over-current protection	25 A

Dimensions & Weight

Hgt	51 in	Len	89 in	Wth	59 in
Weight with factory installed options	1340 lb				

Clearances

Right	12 in	Front	48 in	Rear	36 in
Top	72 in	Bottom	0 in	Left	36 in

Note: Please refer to the tech guide for listed maximum static pressures

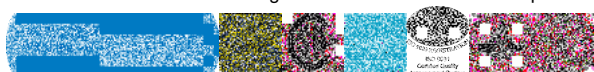

7.5 Ton

- York Sun Pro units are manufactured at an ISO 9001 registered facility and each rooftop is completely computer-run tested prior to shipment.

Unit Features

- Two Stage Cooling
- 180 MBH Input Aluminized Steel, Two Stage Gas Heat
- Full perimeter base rails with built in rigging capabilities
- Unit Cabinet Constructed of Powder Painted Steel, Certified At 750 Hours Salt Spray Test (ASTM B-117 Standards)
- Dry Bulb Low Leak Economizer w/Barometric Relief and Power Exhaust and Hoods (Bottom or Horizontal End Return Only) with Economizer Fault Detection & Diagnostic (Meets ASHRAE 90.1-2013, IECC 2015, California Title 24, AMCA 511).
- 3 HP High Static Belt Drive Blower
- Solid Core Liquid Line Filter Driers
- Unit Ships with 2" Throwaway Filters
- Replacement Filters: 4 - (24" x 20"). Unit accepts 2" or 4" wide filters.
- Non-Powered Convenience Outlet
- HACR Circuit Breaker/Disconnect
- Single Point Power Connection
- Through-the-Curb and Through-the-Base Utility Connections
- Short Circuit Current: 5kA RMS Symmetrical
- Return Air Smoke Detector
- Micro-Channel "all-aluminum" condenser coil, Copper tube/aluminum fin evaporator coil
- Composite Drain Pan - Back Connection
- Tool-free maintenance with features like hinged doors for all-access panels, slide-out blower and blower motor tray

BAS Controller

- IntelliSpeed control of the VFD based on stages of cooling. Provides Single Zone VAV Fan Operation as defined by ASHRAE 90.1 section 6.4.3.10.
- Smart Equipment Controller including Discharge Air, Return Air, and Outdoor Air Temperature Sensors. BACNet MS/TP, Modbus and N2 communication card.

Standard Unit Controller: Smart Equipment Control Board

- Safety Monitoring - Monitors the High and Low-Pressure Switches, the Freezestats, the Gas Valve, if Applicable, and the Temperature Limit Switch on Gas and Electric Heat Units. The Unit Control Board will Alarm on Ignition Failures, Safety Lockouts and Repeated Limit Switch Trips.

Warranty

- One (1) Year Limited Warranty on the Complete Unit
- Five (5) Year Warranty - Compressors and Electric Heater Elements
- Ten (10) Year Limited Warranty - Aluminized Steel Heat Exchanger



York® Sun™ Pro 3-12.5 Ton Package

Single Package R-410A Air Conditioner

Project Name: **Sierra - Evansville, IN REV 1**

Unit Model #: **ZJ090N18R4D5HCA1R3**

Quantity: **1** Tag #: **RTU-4**

System: **ZJ090N18R4D5HCA1R3**

Additional Electrical Data

Power supply	460-3-60
Unit min circuit ampacity	23.8 A
Unit max over-current protection	25 A
Min Voltage	432 V
Max Voltage	504 V
Comp #1 RLA	6.1
Comp #1 LRA	41.0
Comp #2 RLA	6.1
Comp #2 LRA	41
Indoor Mtr Voltage	460-3-60
Indoor Mtr FLA	4.7
Outdoor Mtr Qty	2
Outdoor Fan Voltage	460-1-60
OD Fan Mtr FLA (ea.)	1.6
Power Ex Mtr Qty (if applicable)	1
Powered Ex Voltage(if applicable)	460-1-60
Power Ex Mtr FLA (ea) (if applicable)	2.2
Combustion Mtr Qty	1
Combustion Motor Voltage	208/230-1-60
Combustion Mtr FLA (ea)	0.5



York® Sun™ Pro 3-12.5 Ton Package

Single Package R-410A Air Conditioner

Project Name: **Sierra - Evansville, IN REV 1**

Unit Model #: **ZJ090N18R4D5HCA1R3**

Quantity: **1** Tag #: **RTU-4**

System: **ZJ090N18R4D5HCA1R3**

Factory Installed Options

ZJ090N18R4D5HCA1R3

Equipment Options	Option(s) Selected
Product Category:	ZJ Single Packaged R-410A Air Conditioner, High Efficiency 12.0 EER
Nominal Cooling Capacity:	090 7.5 Ton Two Stage Cooling
Heat Type and Nominal Heat Capacity:	N18 180 MBH Input Aluminized Steel, Two Stage Gas Heat
Blower Option:	R 3 HP High Static Belt Drive Blower IntelliSpeed control of the VFD based on stages of cooling (Provides Single Zone VAV Fan Operation as defined by ASHRAE 90.1 section 6.4.3.10)
Voltage:	4 460-3-60
Outside Air Option:	D Dry Bulb Low Leak Economizer w/Barometric Relief and Power Exhaust and Hoods (Bottom or Horizontal End Return Only) with Economizer Fault Detection & Diagnostic (Meets ASHRAE 90.1-2013, IECC 2015, California Title 24, AMCA 511).
Service Options:	5 Non-Powered Convenience Outlet HACR Circuit Breaker/Disconnect
Sensor Options:	H Return Air Smoke Detector (Bottom return only)
Controls:	C Smart Equipment Controller including Discharge Air, Return Air, and Outdoor Air Temperature Sensors. BACNet MS/TP, Modbus and N2 Communication Card.
Refrigeration:	A Micro-Channel "all-aluminum" condenser coil, Copper tube/aluminum fin evaporator coil
Additional Options:	1 Standard 2" Throwaway Filters Phase Monitor
Cabinet Options:	R Composite Drain Pan - Back Connection Tool-free maintenance with features like hinged doors for all-access panels, slide-out blower and blower motor tray
Product Generation:	3

Field Installed Accessories



York® Sun™ Pro 3-12.5 Ton Package

Single Package R-410A Air Conditioner

Project Name: **Sierra - Evansville, IN REV 1**

Unit Model #: **ZJ090N18R4D5HCA1R3**

Quantity: **1** Tag #: **RTU-4**

System: **ZJ090N18R4D5HCA1R3**

- 1RC0471 - Roof Curb - 14" High, Flat, Uninsulated, Full Perimeter (Shipped Knocked Down) (135.0 lbs)
- 2EC0401 - Kit, Single Enthalpy Field Installed (1.0 lbs)
- 1BD0408 - Burglar Bars (32.0 lbs)
- 1HG0411 - Hail Guard Kit-Diamond Pattern (37.0 lbs)

Single Package R-410A Air Conditioner

 Project Name: **Sierra - Evansville, IN**
REV 1

 Unit Model #: **ZJ090N18R4D5HCA1R3**

 Quantity: 1 Tag #: **RTU-4**

Component Locations

Cooling With Gas Heat (6.5 Through 10 Tons)

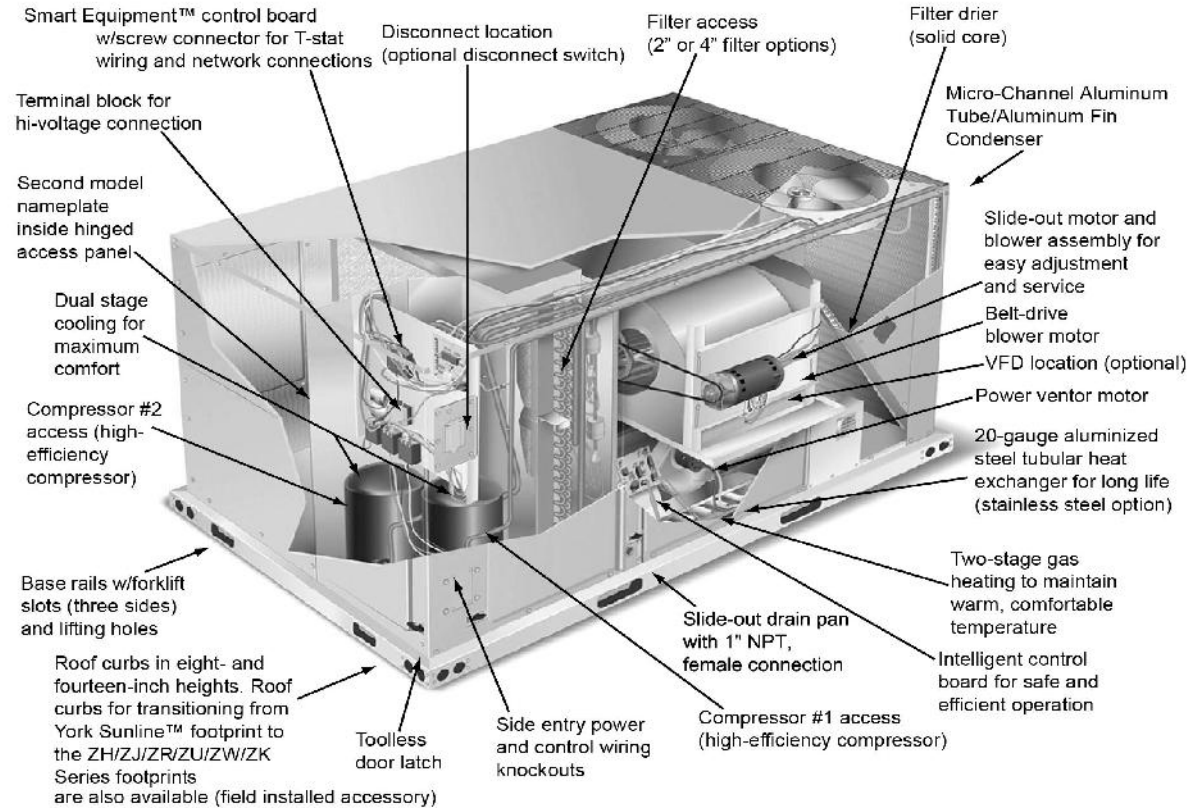

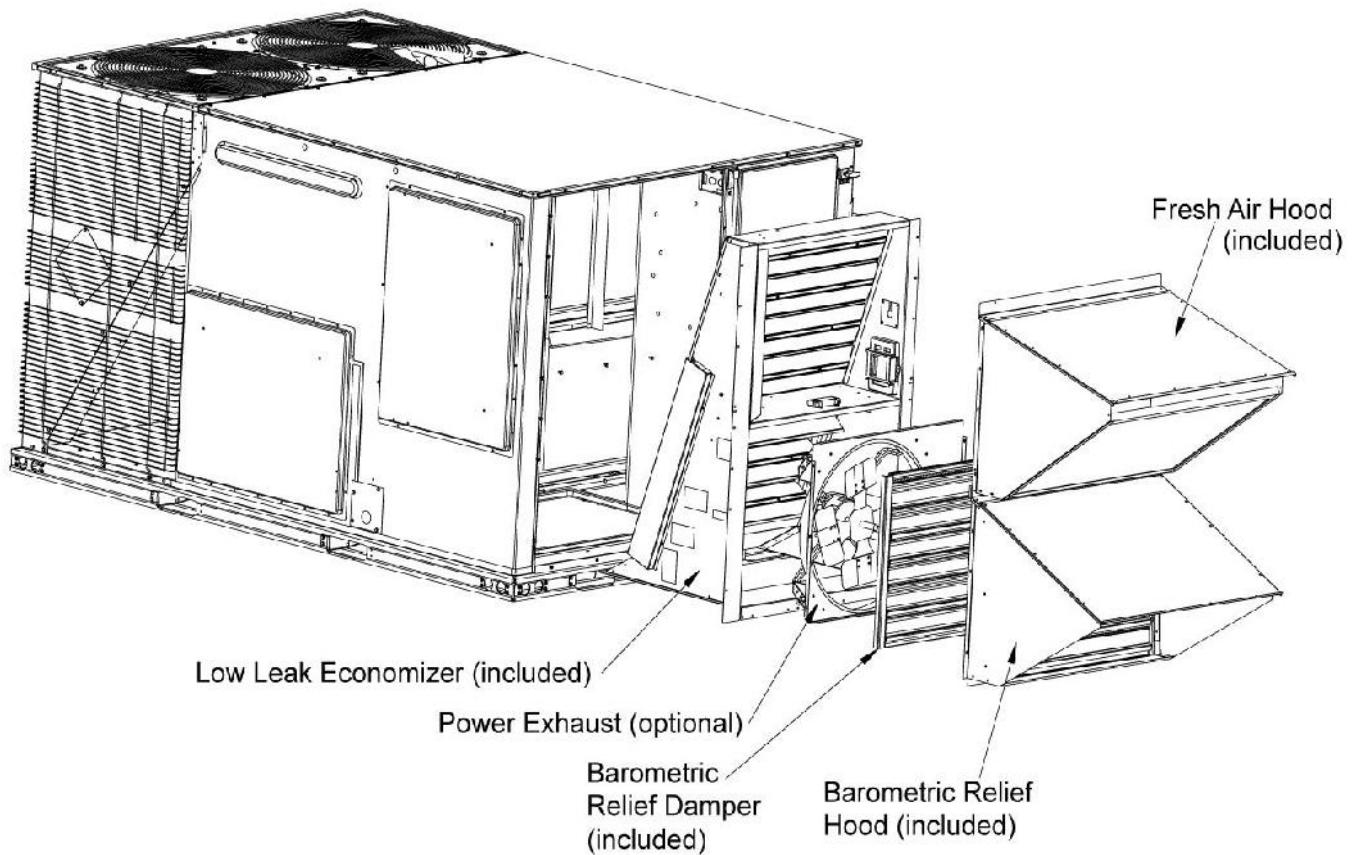
Single Package R-410A Air ConditionerProject Name: **Sierra - Evansville, IN**
REV 1Unit Model #: **ZJ090N18R4D5HCA1R3**Quantity: 1 Tag #: **RTU-4****Low Leak Downflow Economizer****Low Leak Downflow Economizer (shown with optional Power Exhaust)**

Low leak economizers are capable achieving low leakage rates of 3 cfm/sq. ft at 1" of static pressure, meeting or exceeding the following standards:

- ASHRAE 90.1-2010
- ASHRAE 62
- AMCA 511 (licensed as Class 1A damper)
- International Energy Conservation Code (IECC)
- California Title 24

The outdoor intake opening shall be covered with a rain hood that matches the exterior of the unit. Water eliminator/filters shall be provided.

Simultaneous economizer/compressor operation is also possible. Dampers shall fully close on power loss.

Single Package R-410A Air Conditioner

Project Name: **Sierra - Evansville, IN**
REV 1

Unit Model #: **ZJ090N18R4D5HCA1R3**

Quantity: 1 Tag #: **RTU-4**

Factory Installed Power Exhaust

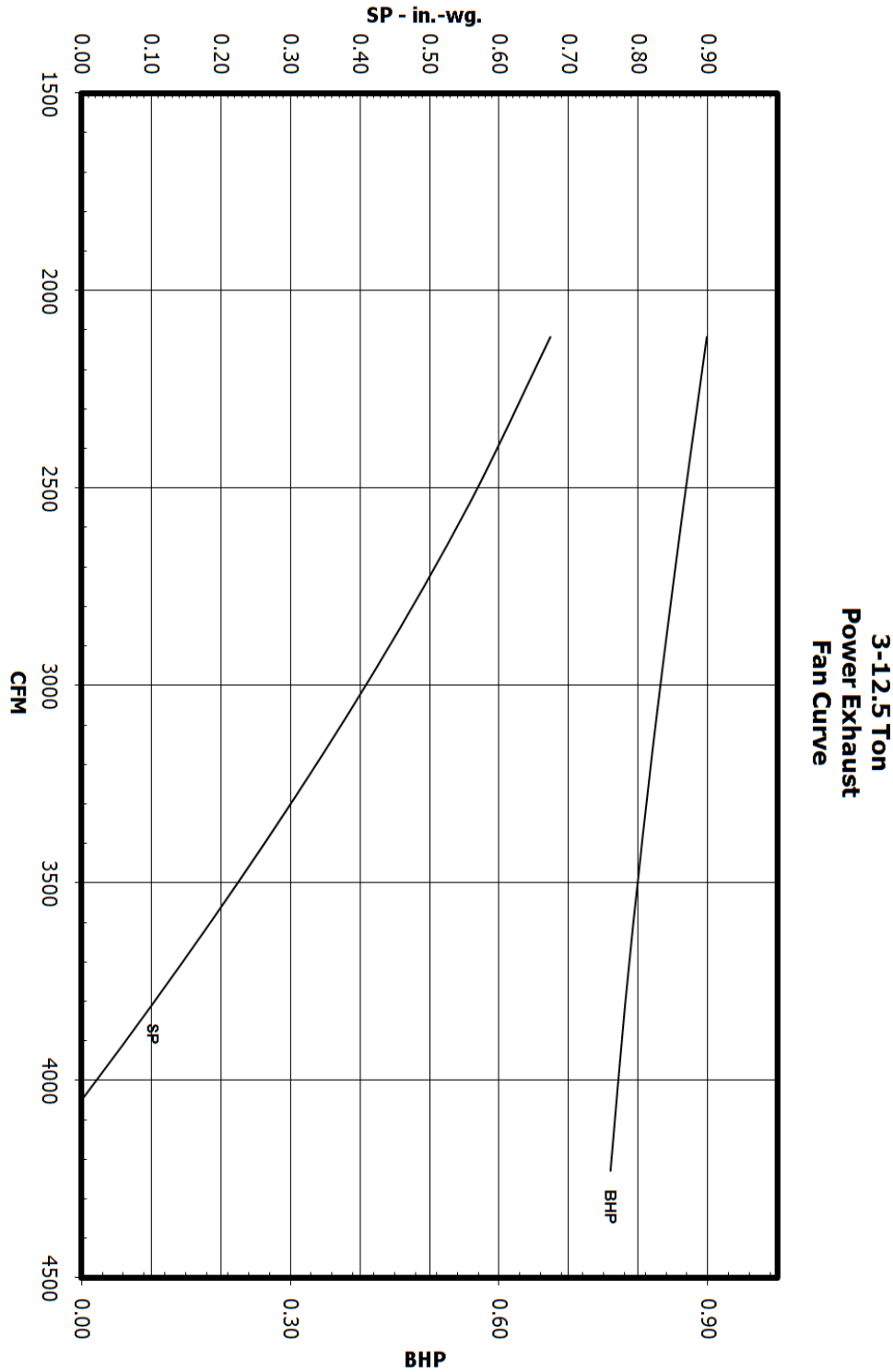

Single Package R-410A Air Conditioner

Project Name: **Sierra - Evansville, IN**
REV 1Unit Model #: **ZJ090N18R4D5HCA1R3**Quantity: 1 Tag #: **RTU-4**

Seismic Certification

**OFFICE OF STATEWIDE HEALTH PLANNING AND DEVELOPMENT
FACILITIES DEVELOPMENT DIVISION**

APPLICATION FOR OSHPD SPECIAL SEISMIC CERTIFICATION PREAPPROVAL (OSP)

OFFICE USE ONLY

APPLICATION #: **OSP - 0213**

OSHPD Special Seismic Certification Preapproval (OSP)

Type: New Renewal

Manufacturer Information

Manufacturer: Johnson Controls Inc. (JCI)Manufacturer's Technical Representative: Cameron Boyce, Engineer IIMailing Address: 5005 Interstate Drive, Norman, OK, 73069Telephone: (405) 419-6830Email: cameron.w.boyce@jci.com

Product Information

Product Name: Predator Rooftop Air Conditioning UnitsProduct Type: Packaged Air Conditioning Units OSP-0213Product Model Number: See attached

(List all unique product identification numbers and/or part numbers)

General Description: The units are enclosures with the following subcomponents: refrigerant compressors, outdoor fan motors, indoor coils, outdoor coils, reversing valve with coil, thermostatic expansion valves, standard indoor blower motor, Variable frequency drive indoor blower motor, exhaust fan motor, variable frequency drive, economizer, electric heater, heat cells, filters, and other miscellaneous items included in the subcomponent tables.Mounting Description: Units are rigid curb and isolated curb base mounted

Applicant Information

Applicant Company Name: The VMC GroupContact Person: John GiulianoMailing Address: 113 Main Street, Bloomingdale, NJ 07403Telephone: (973) 838-1780Email: john.giuliano@thvmcgroup.com

I hereby agree to reimburse the Office of Statewide Health Planning and Development review fees in accordance with the California Administrative Code, 2016.

Signature of Applicant: Date: 8/28/19Title: PresidentCompany Name: The VMC Group*Access to Safe, Quality Healthcare Environments that Meet California's Diverse
STATE OF CALIFORNIA - HEALTH AND HUMAN SERVICES AGENCY
OSH-FD-759 (REV 12/16/15)

Page 1 of 3

Single Package R-410A Air Conditioner

Project Name: **Sierra - Evansville, IN**
REV 1Unit Model #: **ZJ090N18R4D5HCA1R3**Quantity: 1 Tag #: **RTU-4**

Seismic Certification



OFFICE OF STATEWIDE HEALTH PLANNING AND DEVELOPMENT FACILITIES DEVELOPMENT DIVISION

California Licensed Structural Engineer Responsible for the Engineering and Test Report(s)

Company Name: The VMC GroupName: Kenneth Tarlow California License Number: SE-2851Mailing Address: 113 Main Street, Bloomingdale, NJ 07403Telephone: (973) 838-1780 Email: ken.tarlow@thevmcgroup.com

Supports and Attachments Preapproval

- Supports and attachments are preapproved under OPM- _____
(Separate application for OSHPD Preapproval of Manufacturer's Certification (OPM) of Supports and attachments is required)
- Supports and attachments are not preapproved

Certification Method

- Testing in accordance with: ICC-ES AC156
- Other (Please Specify): _____

Testing Laboratory

Company Name: DCL LabsContact Name: Josh Sailer, Laboratory ManagerMailing Address: 1315 Greg Street, Suite 109, Sparks, NV 89431Telephone: (775) 358-5085 Email: josh@shaketest.com

*Access to Safe, Quality Healthcare Environments that Meet California's Diverse

STATE OF CALIFORNIA – HEALTH AND HUMAN SERVICES AGENCY
OSH-FD-759 (REV 12/16/15)

Page 2 of 3

Single Package R-410A Air Conditioner

Project Name: **Sierra - Evansville, IN**
REV 1Unit Model #: **ZJ090N18R4D5HCA1R3**Quantity: 1 Tag #: **RTU-4**

Seismic Certification



OFFICE OF STATEWIDE HEALTH PLANNING AND DEVELOPMENT FACILITIES DEVELOPMENT DIVISION

Seismic Parameters

Design in accordance with ASCE 7-16 Chapter 13: Yes NoDesign Basis of Equipment or Components (F_p/W_p) = Rigid Curb = 1.5; Spring Isolated Curb = 4.5 S_{DS} (Design spectral response acceleration at short period, g) = 2.00 a_p (In-structure equipment or component amplification factor) = 2.5 R_p (Equipment or component response modification factor) = Rigid Curb = 6.0; Spring Isolated Curb = 2.0 Ω_0 (System overstrength factor) = 2.0 I_p (Importance factor) = 1.5 z/h (Height factor ratio) = 1Equipment or Component Natural Frequencies (Hz) = See attachmentOverall dimensions and weight (or range thereof) = See attachmentEquipment or Components @ grade designed in accordance with ASCE 7-16 Chapter 15: Yes NoDesign Basis of Equipment or Components (V/W) = _____ S_{DS} (Design spectral response acceleration at short period, g) = _____ S_{D1} (Design spectral response acceleration at 1 second period, g) = _____ R (Response modification coefficient) = _____ Ω_0 (System overstrength factor) = By: Timothy J Piland C_d (Deflection amplification factor) = _____ I_p (Importance factor) = 1.5

Height to Center of Gravity above base = _____

Equipment or Component Natural Frequencies (Hz) = _____

Overall dimensions and weight (or range thereof) = _____

Tank(s) designed in accordance with ASME BPVC, 2015: Yes No

List of Attachments Supporting Special Seismic Certification

 Test Report(s) Drawings Calculations Manufacturer's Catalog Other(s) (Please Specify): _____

OSHPD Approval (For Office Use Only) – Approval Expires on December 31, 2025

Signature:  Date: March 8, 2021Print Name: Timothy J. Piland Title: SSESpecial Seismic Certification Valid Up to: S_{DS} (g) = 2.00 z/h = 1

Condition of Approval (if applicable): _____

*Access to Safe, Quality Healthcare Environments that Meet California's Diverse

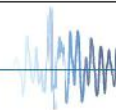
STATE OF CALIFORNIA – HEALTH AND HUMAN SERVICES AGENCY
OSH-FD-759 (REV 12/16/15)

Page 3 of 3

Single Package R-410A Air Conditioner

 Project Name: **Sierra - Evansville, IN**
 REV 1

 Unit Model #: **ZJ090N18R4D5HCA1R3**

Quantity: 1 Tag #: RTU-4

Seismic Certification

Table 1 - Certified Components

Manufacturer: Johnson Controls and other Unitary Product Group brands (York, Coleman, Luxaire, Evcon, Fraser-Johnston and Ready Ship)

Product Line: JCI Packaged Rooftop Units

Product Construction: Cabinet's constructed of G90 galvanized 1,000 hour salt spray (per ASTM B117) rated powder coated 20 gage carbon steel wrapper and duct panel with integral corner posts, all attached at the base to four (4) full perimeter 14 gage base rails with 410 sheet metal screws.

Options: 230-575 V, economizer, power exhaust, electric or gas heater, variable frequency drive

Mounting Description: Rigid or Flexible Curb Mounting

Product Line	Model Number ²	Dimensions (inches)			Operating Weight (lb)	Nominal Cooling Capacity (Tons)	5dK (g), z/h=1	Unit
		Depth	Width	Height				
Precorator Air Handling Units (Short)	ZH/ZU/JA3 037	89	59	42	860 ¹	3	2.0	3
	ZJ/ZW/JA3 037	89	59	42	740	3		Interpolated
	ZR/ZK/JA3 037	89	59	42	980 ¹	3		1
	ZT/ZV/JA3 037	89	59	42	927	3		Interpolated
	ZH/ZU/JA4 049	89	59	42	763	4		Interpolated
	ZJ/ZW/JA4 049	89	59	42	762	4		Interpolated
	ZR/ZK/JA4 049	89	59	42	880	4		Interpolated
	ZT/ZV/JA4 049	89	59	42	960	4		Interpolated
	ZJ/ZW/JA5 061	89	59	42	777	5		Interpolated
	ZJ/ZW/JA5 061	89	59	42	1,070 ¹	5		4
	ZR/ZK/JA5 061	89	59	42	1,070 ¹	5		7
	ZT/ZV/JA5 061	89	59	42	968	5		Extrapolated
Precorator Air Handling Units (Standard)	XF/XA/J06 078	89	59	42	970 ¹	6.5	2.0	7
	ZF/ZS/J06 078	89	59	42	1,090 ¹	6.5		10
	ZH/ZL/J06 078	89	59	42	910	6.5		Interpolated
	ZJ/ZW/J06 078	89	59	51	1,030	6.5		Interpolated
	ZK/ZC/J06 078	89	59	51	1,050 ¹	6.5		5
	ZF/ZS/J07 090	89	59	42	860	7.5		Interpolated
	ZH/ZL/J07 090	89	59	42	910	7.5		Interpolated
	ZJ/ZW/J07 090	89	59	51	1,081	7.5		Interpolated
	XF/XA/J07 090	89	59	42	920	7.5		Interpolated
	ZR/ZK/J07 090	89	59	42	965	7.5		Interpolated
	ZF/ZS/J08 102	89	59	51	1,020	8.5		Interpolated
	ZH/ZL/J08 102	89	59	51	1,030	8.5		Interpolated
	ZJ/ZW/J08 102	89	59	51	1,135	8.5		Interpolated
	ZR/ZK/J08 102	89	59	51	1,200	8.5		Interpolated
	ZF/ZS/J10 120	89	59	51	1,050	10		Interpolated
	ZH/ZL/J10 120	89	59	51	1,090	10		Interpolated
	ZJ/ZW/J10 120	89	59	51	1,070	10		Interpolated
	XI/XA/J10 120	89	59	51	1,135	10		Interpolated
	ZR/ZK/J10 120	89	59	51	1,200	10		Interpolated
	ZF/ZS/J12 150	119.5	59	51	1,253	12.5		Interpolated
	ZH/ZL/J12 150	119.5	59	51	1,250 ¹	12.5		11
	XF/XA/J12 150	119.5	59	51	1,510 ¹	12.5		8
	ZJ/ZW/J12 150	119.5	59	51	1,570 ¹	12.5		9
	ZR/ZK/J12 150	119.5	59	51	1,500 ¹	12.5		6
Precorator Air Handling Units (Ultra High Efficiency)	ZJ/ZV 120	119.5	59	51	1,470 ¹	10	2.0	12
	ZT/ZV 078	119.5	59	51	1,550	6.5		Interpolated
	ZT/ZV 090	119.5	59	51	1,550	7.5		Interpolated
	ZT/ZV 102	119.5	59	51	1,575	8.5		Interpolated
	ZT/ZV 150	119.5	59	51	1,840 ¹	12.5	13	

1. Weights listed for tested units are actual, not approximate weights. The weights listed for interpolated units are maximum weights, assuming all optional features are included. Optional features are summarized in the table below.

2. Model numbers are generalized for each type of unit and the associated BTU tonnage that the unit can output.

Unit Accessory	Operating Weight (lbs.)
Economizer	85
Power Exhaust	35
Electric Heat	49
Gas Heat	110
Variable Frequency Drive	30

1. Weight given is for the maximum electric heater size available.

2. Weight given for the gas heater is for the maximum number of tube heat exchangers available (8 tube).

3. Weight includes mounting hardware, controls and manual bypass option.

Single Package R-410A Air Conditioner

Project Name: **Sierra - Evansville, IN**
REV 1

Unit Model #: **ZJ090N18R4D5HCA1R3**

Quantity: 1 Tag #: **RTU-4**

1RC0471 Roof Curb

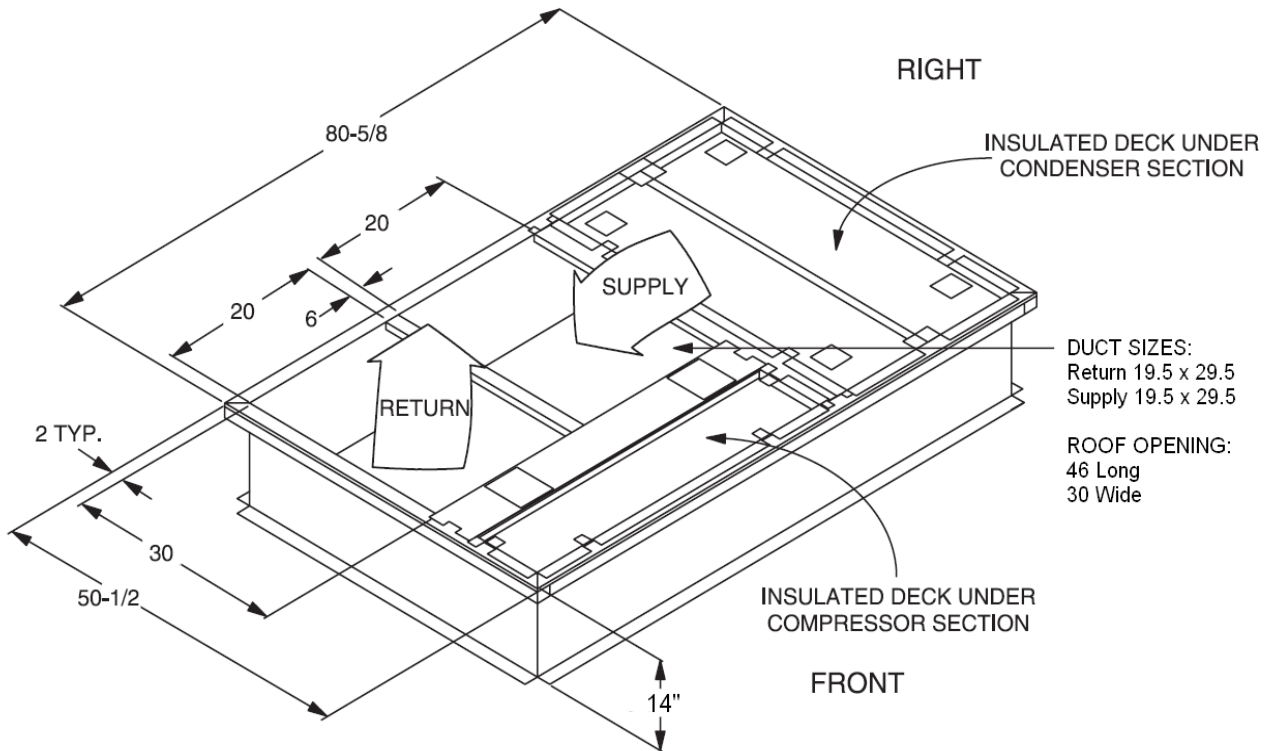

DUCT SIZES:
 Return 19.5 x 29.5
 Supply 19.5 x 29.5

ROOF OPENING:
 46 Long
 30 Wide

* Supply and Return Air (Including duct support rails) as shown, are typical for bottom duct applications.
 For location of horizontal duct applications (On rear of unit), refer to Unit Dimensions details.

1RC0471 Roof Curb Dimensions

Single Package R-410A Air Conditioner

 Project Name: **Sierra - Evansville, IN REV 1**

 Unit Model #: **ZT037N08P4B5HCA1R3**

 Quantity: **3** Tag #: **RTU-6,7,9**

 System: **ZT037N08P4B5HCA1R3**

Cooling Performance

Total gross capacity	40.0 MBH
Sensible gross capacity	27.3 MBH
Total net capacity	38.4 MBH
Sensible net capacity	25.7 MBH
Seasonal Efficiency (at ARI)	17.00 SEER
Seasonal Efficiency (at ARI)	16.20 SEER2
Efficiency (at ARI)	13.05 EER
Efficiency (at ARI)	12.90 EER2
Ambient DB temp.	95.0 °F
Entering DB temp.	80.0 °F
Entering WB temp.	67.0 °F
Evap Coil Leaving DB temp.	58.9 °F
Evap Coil Leaving WB temp.	56.4 °F
Unit Leaving DB temp.	60.2 °F
Unit Leaving WB temp.	56.9 °F
Leaving air temp dew point	54.70 °F
Power input (w/o blower)	2.38 kW
Sound power	75 dB(a)

Refrigerant

Refrigerant type	R-410A
Sys1	10 lb 5 oz

Gas Heating Performance

Entering DB temp.	60 °F
Heating output capacity (Max)	65.0 MBH
Supply air	1200 cfm
Heating input capacity (Max)	80 MBH
Leaving DB temp.	110.2 °F
Air temp. rise	50.2 °F
SSE	81.0 %
Stages	2

Supply Air Blower Performance

Supply air	1200 cfm
Ext. static pressure	0.6 IWG
Blower speed	736 rpm
Max BHP of Motor (including service factor)	1.73 HP
Duct location	Bottom
Motor rating	1.50 HP
Actual required BHP	0.50 HP
Power input	0.47 kW
Elevation	0 ft
Drive type	BELT

Electrical Data

Power supply	460-3-60
Unit min circuit ampacity	12.4 A
Unit max over-current protection	15 A

Dimensions & Weight

Hgt 42 in	Len 89 in	Wth 59 in
Weight with factory installed options 1060 lb		

Clearances

Right	12 in	Front	36 in	Rear	36 in
Top	72 in	Bottom	0 in	Left	36 in

Note: Please refer to the tech guide for listed maximum static pressures

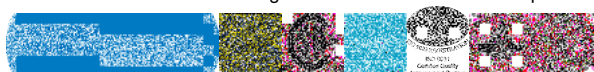

3 Ton

- York Sun Pro units are manufactured at an ISO 9001 registered facility and each rooftop is completely computer-run tested prior to shipment.

Unit Features

- Two Stage Cooling
- 80 MBH Input Aluminized Steel, Two Stage Gas Heat
- Full perimeter base rails with built in rigging capabilities
- Unit Cabinet Constructed of Powder Painted Steel, Certified At 750 Hours Salt Spray Test (ASTM B-117 Standards)
- Dry Bulb Low Leak Economizer w/Barometric Relief and Hoods (Bottom or Horizontal End Return Only) with Economizer Fault Detection & Diagnostic (Meets ASHRAE 90.1-2013, IECC 2015, California Title 24, AMCA 511).
- VFD Standard
- Slide-Out Blower/1.5 HP Belt Drive Motor Assembly
- Solid Core Liquid Line Filter Driers
- Unit Ships with 2" Throwaway Filters
- Replacement Filters: 4 - (24" x 16"). Unit accepts 2" or 4" wide filters.
- Non-Powered Convenience Outlet
- HACR Circuit Breaker/Disconnect
- Single Point Power Connection
- Through-the-Curb and Through-the-Base Utility Connections
- Short Circuit Current: 5kA RMS Symmetrical
- Return Air Smoke Detector
- Micro-Channel "all-aluminum" condenser coil, Copper tube/aluminum fin evaporator coil
- Composite Drain Pan - Back Connection
- Tool-free maintenance with features like hinged doors for all-access panels, slide-out blower and blower motor tray

BAS Controller

- IntelliSpeed control of the VFD based on stages of cooling. Provides Single Zone VAV Fan Operation as defined by ASHRAE 90.1 section 6.4.3.10.

Standard Unit Controller: Smart Equipment Control Board

- Safety Monitoring - Monitors the High and Low-Pressure Switches, the Freezestats, the Gas Valve, if Applicable, and the Temperature Limit Switch on Gas and Electric Heat Units. The Unit Control Board will Alarm on Ignition Failures, Safety Lockouts and Repeated Limit Switch Trips.

Warranty

- One (1) Year Limited Warranty on the Complete Unit
- Five (5) Year Warranty - Compressors and Electric Heater Elements
- Ten (10) Year Limited Warranty - Aluminized Steel Heat Exchanger



York® Sun™ Pro 3-12.5 Ton Package

Single Package R-410A Air Conditioner

Project Name: **Sierra - Evansville, IN REV 1**

Unit Model #: **ZT037N08P4B5HCA1R3**

Quantity: **3** Tag #: **RTU-6,7,9**

System: **ZT037N08P4B5HCA1R3**

Additional Electrical Data

Power supply	460-3-60
Unit min circuit ampacity	12.4 A
Unit max over-current protection	15 A
Min Voltage	432 V
Max Voltage	504 V
Comp #1 RLA	5.7
Comp #1 LRA	38.0
Indoor Mtr Voltage	460-3-60
Indoor Mtr FLA	2.1
Outdoor Mtr Qty	2
Outdoor Fan Voltage	460-1-60
OD Fan Mtr FLA (ea.)	1.6
Power Ex Mtr Qty (if applicable)	1
Powered Ex Voltage(if applicable)	460-1-60
Power Ex Mtr FLA (ea) (if applicable)	2.2
Combustion Mtr Qty	1
Combustion Motor Voltage	208/230-1-60
Combustion Mtr FLA (ea)	0.5



York® Sun™ Pro 3-12.5 Ton Package

Single Package R-410A Air Conditioner

Project Name: Sierra - Evansville, IN REV 1

Unit Model #: ZT037N08P4B5HCA1R3

Quantity: 3 Tag #: RTU-6,7,9

System: ZT037N08P4B5HCA1R3

Factory Installed Options

ZT037N08P4B5HCA1R3

Equipment Options	Option(s) Selected
Product Category:	ZT Single Packaged R-410A Ultra High Efficiency Air Conditioner
Nominal Cooling Capacity:	037 3 Ton Two Stage Cooling
Heat Type and Nominal Heat Capacity:	N08 80 MBH Input Aluminized Steel, Two Stage Gas Heat
Blower Option:	P VFD Standard 1.5 HP Standard Static Belt Drive Blower IntelliSpeed control of the VFD based on stages of cooling (Provides Single Zone VAV Fan Operation as defined by ASHRAE 90.1 section 6.4.3.10)
Voltage:	4 460-3-60
Outside Air Option:	B Dry Bulb Low Leak Economizer w/Barometric Relief and Hoods (Bottom or Horizontal End Return Only) with Economizer Fault Detection & Diagnostic (Meets ASHRAE 90.1-2013, IECC 2015, California Title 24, AMCA 511).
Service Options:	5 Non-Powered Convenience Outlet HACR Circuit Breaker/Disconnect
Sensor Options:	H Return Air Smoke Detector (Bottom return only)
Controls:	C Smart Equipment Controller including Discharge Air, Return Air, and Outdoor Air Temperature Sensors. BACNet MS/TP, Modbus and N2 Communication Card.
Refrigeration:	A Micro-Channel "all-aluminum" condenser coil, Copper tube/aluminum fin evaporator coil
Additional Options:	1 Standard 2" Throwaway Filters Phase Monitor
Cabinet Options:	R Composite Drain Pan - Back Connection Tool-free maintenance with features like hinged doors for all-access panels, slide-out blower and blower motor tray
Product Generation:	3

Field Installed Accessories

● 1RC0471 - Roof Curb - 14" High, Flat, Uninsulated, Full Perimeter (Shipped Knocked Down) (135.0 lbs)

● 2EC0401 - Kit, Single Enthalpy Field Installed (1.0 lbs)
● 1BD0408 - Burglar Bars (32.0 lbs)

● 1HG0415 - Hail Guard Kit-Diamond Pattern (50.0 lbs)



**York® Sun™ Pro 3-12.5 Ton
Package**

Single Package R-410A Air Conditioner

Project Name: **Sierra - Evansville, IN REV 1**

Unit Model #: **ZT037N08P4B5HCA1R3**

Quantity: **3** Tag #: **RTU-6,7,9**

System: **ZT037N08P4B5HCA1R3**

Project Name: **Sierra - Evansville, IN REV 1**

 Unit Model #: **ZT037N08P4B5HCA1R3**

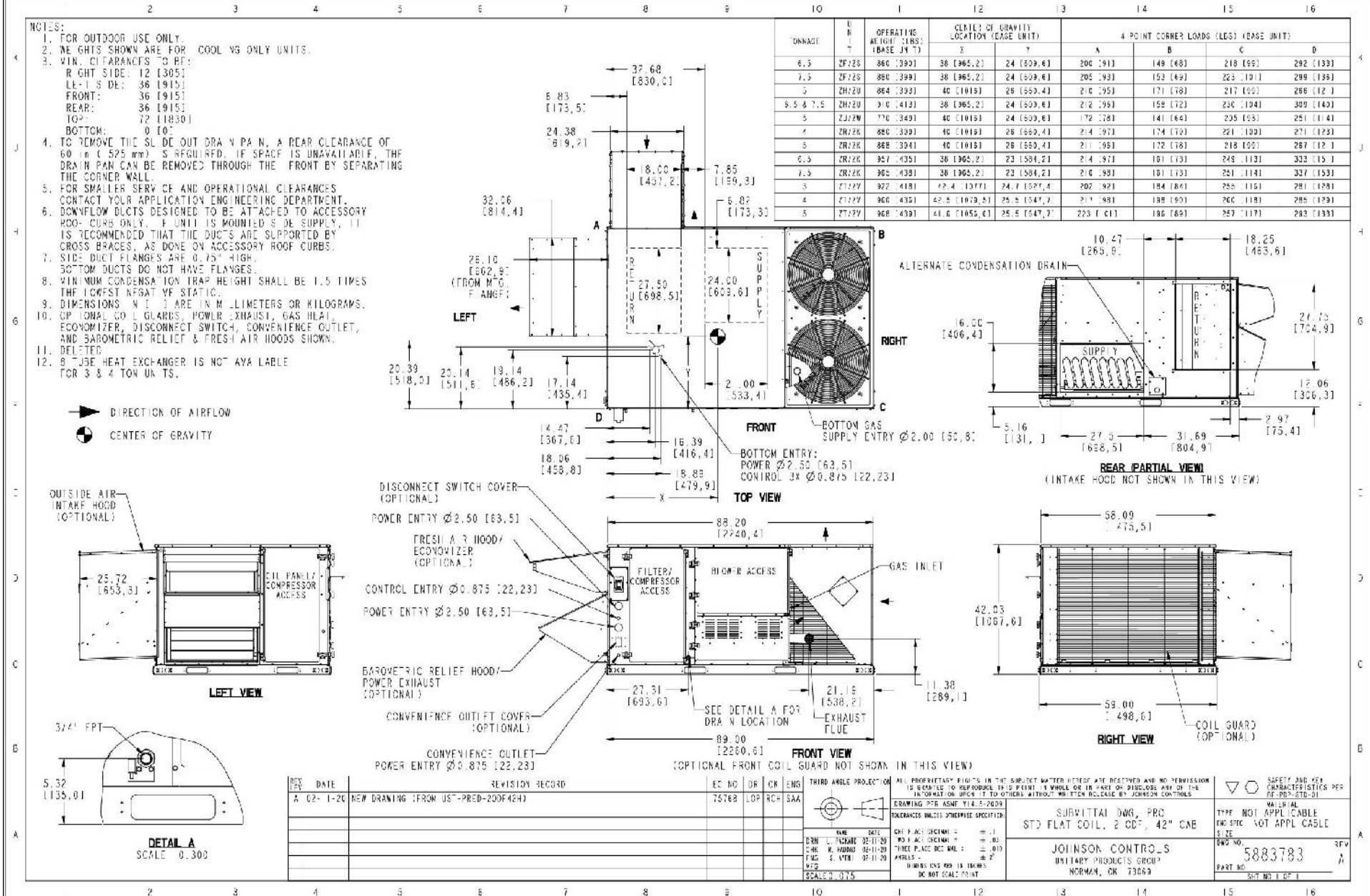
 Quantity: **3** Tag #: **RTU-6,7,9**
Consolidated Drawing

Single Package R-410A Air Conditioner

Project Name: **Sierra - Evansville, IN**
REV 1

Unit Model #: **ZT037N08P4B5HCA1R3**

Quantity: **3** Tag #: **RTU-6,7,9**

Component Locations

Component Location

Cooling With Gas Heat (3 Through 5 Ton)

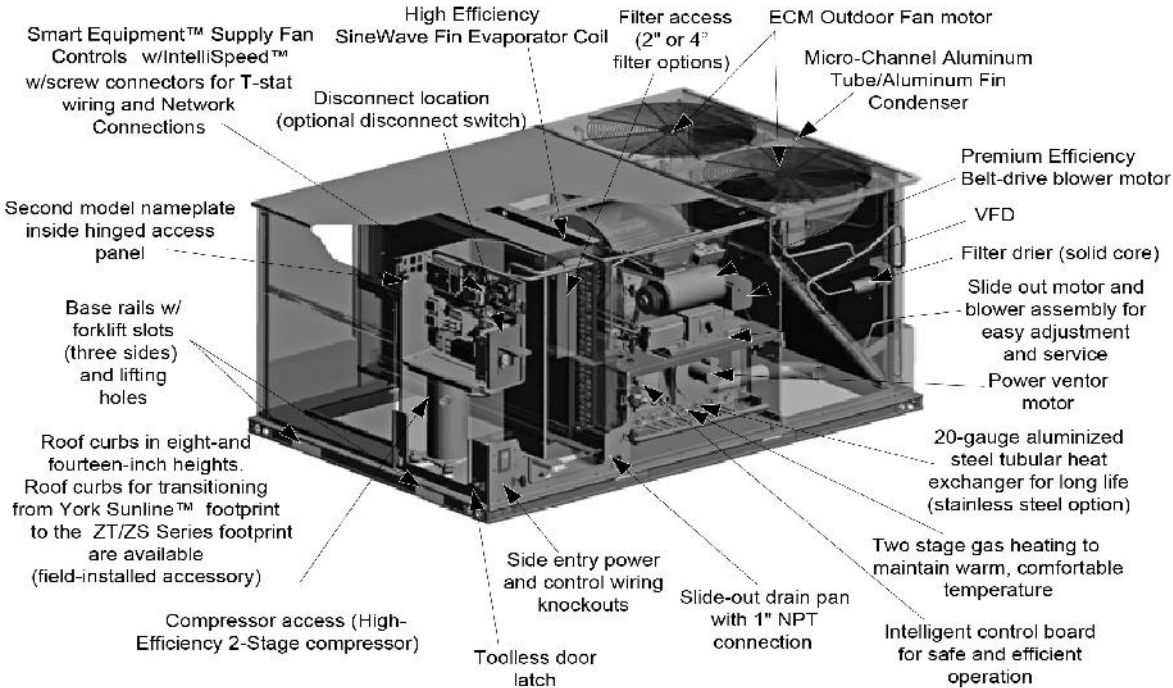

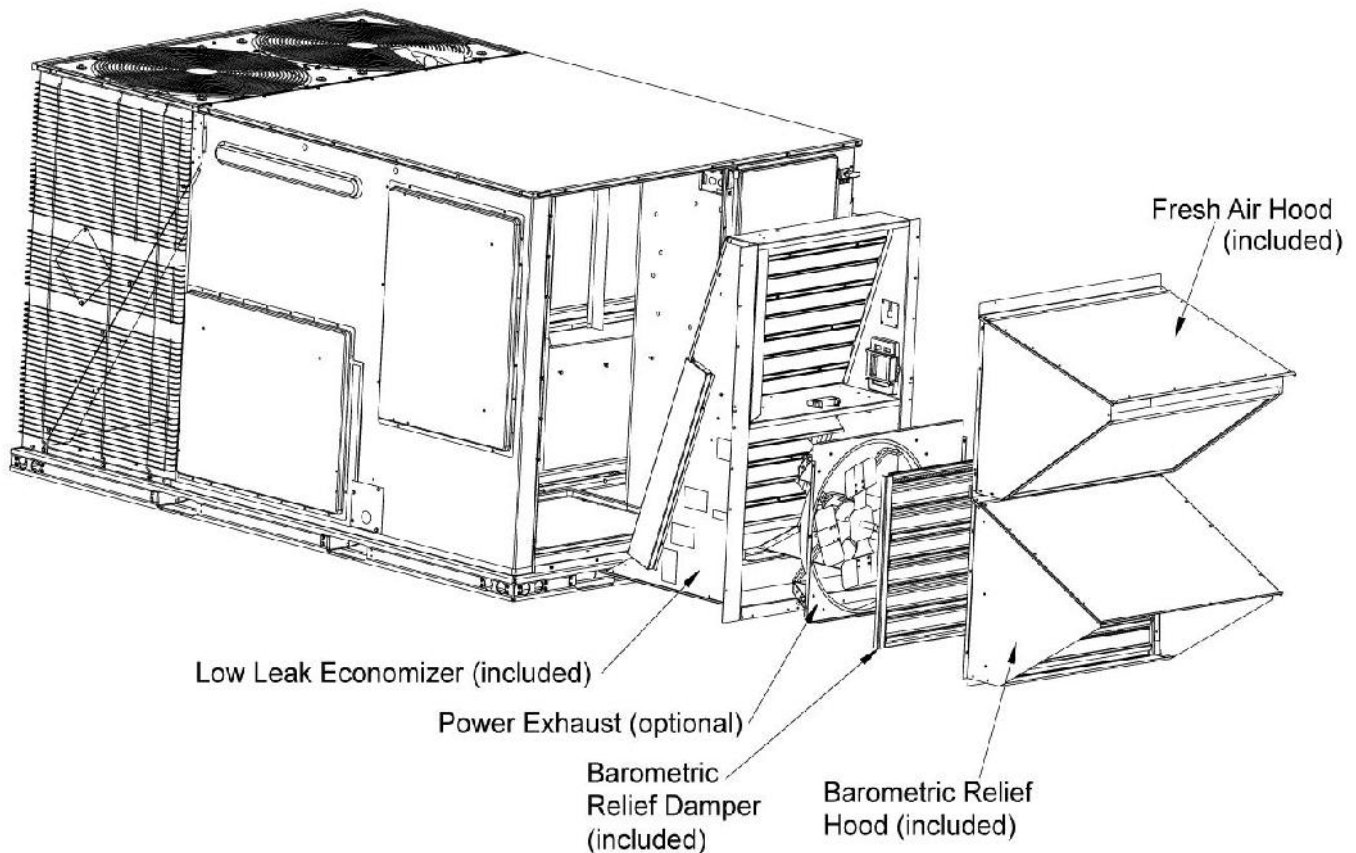
Single Package R-410A Air ConditionerProject Name: **Sierra - Evansville, IN**
REV 1Unit Model #: **ZT037N08P4B5HCA1R3**Quantity: **3** Tag #: **RTU-6,7,9****Low Leak Downflow Economizer****Low Leak Downflow Economizer (shown with optional Power Exhaust)**

Low leak economizers are capable achieving low leakage rates of 3 cfm/sq. ft at 1" of static pressure, meeting or exceeding the following standards:

- ASHRAE 90.1-2010
- ASHRAE 62
- AMCA 511 (licensed as Class 1A damper)
- International Energy Conservation Code (IECC)
- California Title 24

The outdoor intake opening shall be covered with a rain hood that matches the exterior of the unit. Water eliminator/filters shall be provided.

Simultaneous economizer/compressor operation is also possible. Dampers shall fully close on power loss.

Single Package R-410A Air Conditioner

Project Name: **Sierra - Evansville, IN**
REV 1Unit Model #: **ZT037N08P4B5HCA1R3**Quantity: **3** Tag #: **RTU-6,7,9**

Seismic Certification



OFFICE OF STATEWIDE HEALTH PLANNING AND DEVELOPMENT FACILITIES DEVELOPMENT DIVISION

APPLICATION FOR OSHPD SPECIAL SEISMIC CERTIFICATION PREAPPROVAL (OSP)

OFFICE USE ONLY

APPLICATION #: **OSP - 0213**

OSHPD Special Seismic Certification Preapproval (OSP)

Type: New Renewal

Manufacturer Information

Manufacturer: Johnson Controls Inc. (JCI)Manufacturer's Technical Representative: Cameron Boyce, Engineer IIMailing Address: 5005 Interstate Drive, Norman, OK, 73069Telephone: (405) 419-6830Email: cameron.w.boyce@jci.com

Product Information

Product Name: Predator Rooftop Air Conditioning UnitsProduct Type: Packaged Air Conditioning Units OSP-0213Product Model Number: See attached

(List all unique product identification numbers and/or part numbers)

General Description: The units are enclosures with the following subcomponents: refrigerant compressors, outdoor fan motors, indoor coils, outdoor coils, reversing valve with coil, thermostatic expansion valves, standard indoor blower motor, Variable frequency drive indoor blower motor, exhaust fan motor, variable frequency drive, economizer, electric heater, heat cells, filters, and other miscellaneous items included in the subcomponent tables.

Mounting Description: Units are rigid curb and isolated curb base mounted

Applicant Information

Applicant Company Name: The VMC GroupContact Person: John GiulianoMailing Address: 113 Main Street, Bloomingdale, NJ 07403Telephone: (973) 838-1780Email: john.giuliano@thvmcgroup.com

I hereby agree to reimburse the Office of Statewide Health Planning and Development review fees in accordance with the California Administrative Code, 2016.

Signature of Applicant: Date: 8/28/19Title: PresidentCompany Name: The VMC Group

*Access to Safe, Quality Healthcare Environments that Meet California's Diverse
STATE OF CALIFORNIA - HEALTH AND HUMAN SERVICES AGENCY
OSH-FD-759 (REV 12/16/15)



Page 1 of 3

Single Package R-410A Air Conditioner

Project Name: **Sierra - Evansville, IN**
REV 1Unit Model #: **ZT037N08P4B5HCA1R3**Quantity: **3** Tag #: **RTU-6,7,9**

Seismic Certification



OFFICE OF STATEWIDE HEALTH PLANNING AND DEVELOPMENT FACILITIES DEVELOPMENT DIVISION

California Licensed Structural Engineer Responsible for the Engineering and Test Report(s)

Company Name: The VMC GroupName: Kenneth Tarlow California License Number: SE-2851Mailing Address: 113 Main Street, Bloomingdale, NJ 07403Telephone: (973) 838-1780 Email: ken.tarlow@thevmcgroup.com

Supports and Attachments Preapproval

- Supports and attachments are preapproved under OPM- _____
(Separate application for OSHPD Preapproval of Manufacturer's Certification (OPM) of Supports and attachments is required)
- Supports and attachments are not preapproved

Certification Method

- Testing in accordance with: ICC-ES AC156
- Other (Please Specify): _____

BY: Timothy J Piland

DATE: 03/08/2021

Testing Laboratory

Company Name: DCL LabsContact Name: Josh Sailer, Laboratory ManagerMailing Address: 1315 Greg Street, Suite 109, Sparks, NV 89431Telephone: (775) 358-5085 Email: josh@shaketest.com

*Access to Safe, Quality Healthcare Environments that Meet California's Diverse

STATE OF CALIFORNIA – HEALTH AND HUMAN SERVICES AGENCY
OSH-FD-759 (REV 12/16/15)

Page 2 of 3

Single Package R-410A Air Conditioner

Project Name: **Sierra - Evansville, IN**
REV 1Unit Model #: **ZT037N08P4B5HCA1R3**Quantity: **3** Tag #: **RTU-6,7,9**

Seismic Certification



OFFICE OF STATEWIDE HEALTH PLANNING AND DEVELOPMENT FACILITIES DEVELOPMENT DIVISION

Seismic Parameters

Design in accordance with ASCE 7-16 Chapter 13: Yes NoDesign Basis of Equipment or Components (F_p/W_p) = Rigid Curb = 1.5; Spring Isolated Curb = 4.5 S_{DS} (Design spectral response acceleration at short period, g) = 2.00 a_p (In-structure equipment or component amplification factor) = 2.5 R_p (Equipment or component response modification factor) = Rigid Curb = 6.0; Spring Isolated Curb = 2.0 Ω_0 (System overstrength factor) = 2.0 I_p (Importance factor) = 1.5 z/h (Height factor ratio) = 1Equipment or Component Natural Frequencies (Hz) = See attachmentOverall dimensions and weight (or range thereof) = See attachmentEquipment or Components @ grade designed in accordance with ASCE 7-16 Chapter 15: Yes NoDesign Basis of Equipment or Components (V/W) = _____ S_{DS} (Design spectral response acceleration at short period, g) = _____ S_{D1} (Design spectral response acceleration at 1 second period, g) = _____ R (Response modification coefficient) = _____ Ω_0 (System overstrength factor) = By: Timothy J Piland C_n (Deflection amplification factor) = _____ I_p (Importance factor) = 1.5

Height to Center of Gravity above base = _____

Equipment or Component Natural Frequencies (Hz) = _____

Overall dimensions and weight (or range thereof) = _____

Tank(s) designed in accordance with ASME BPVC, 2015: Yes No

List of Attachments Supporting Special Seismic Certification

 Test Report(s) Drawings Calculations Manufacturer's Catalog Other(s) (Please Specify): _____

OSHPD Approval (For Office Use Only) – Approval Expires on December 31, 2025

Signature:  Date: March 8, 2021Print Name: Timothy J. Piland Title: SSESpecial Seismic Certification Valid Up to: S_{DS} (g) = 2.00 z/h = 1

Condition of Approval (if applicable): _____

*Access to Safe, Quality Healthcare Environments that Meet California's Diverse

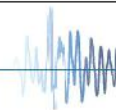
STATE OF CALIFORNIA – HEALTH AND HUMAN SERVICES AGENCY
OSH-FD-759 (REV 12/16/15)

Page 3 of 3

Single Package R-410A Air Conditioner

 Project Name: **Sierra - Evansville, IN**
 REV 1

 Unit Model #: **ZT037N08P4B5HCA1R3**

 Quantity: **3** Tag #: **RTU-6,7,9**

Seismic Certification

Table 1 - Certified Components

Manufacturer: Johnson Controls and other Unitary Product Group brands (York, Coleman, Luxaire, Evcon, Fraser-Johnston and Ready Ship)

Product Line: JCI Packaged Rooftop Units

Product Construction: Cabinet's constructed of G90 galvanized 1,000 hour salt spray (per ASTM B117) rated powder coated 20 gage carbon steel wrapper and duct panel with integral corner posts, all attached at the base to four (4) full perimeter 14 gage base rails with 410 sheet metal screws.

Options: 230-575 V, economizer, power exhaust, electric or gas heater, variable frequency drive

Mounting Description: Rigid or Flexible Curb Mounting

Product Line	Model Number ²	Dimensions (inches)			Operating Weight (lb)	Nominal Cooling Capacity (Tons)	5dks (g), z/h=1	Unit
		Depth	Width	Height				
Precorator Air Handling Units (Short)	ZH/ZU/JA3 037	89	59	42	860 ¹	3	2.0	3
	ZJ/ZW/JA3 037	89	59	42	740	3		Interpolated
	ZR/ZK/JA3 037	89	59	42	980 ¹	3		1
	ZT/ZV/JA3 037	89	59	42	927	3		Interpolated
	ZH/ZU/JA4 049	89	59	42	763	4		Interpolated
	ZJ/ZW/JA4 049	89	59	42	762	4		Interpolated
	ZR/ZK/JA4 049	89	59	42	880	4		Interpolated
	ZT/ZV/JA4 049	89	59	42	960	4		Interpolated
	ZJ/ZW/JA5 061	89	59	42	777	5		Interpolated
	ZJ/ZW/JA5 061	89	59	42	1,070 ¹	5		4
	ZR/ZK/JA5 061	89	59	42	1,070 ¹	5		7
ZT/ZV/JA5 061	89	59	42	968	5	Extrapolated		
Precorator Air Handling Units (Standard)	XF/XA/J06 078	89	59	42	970 ¹	6.5	2.0	7
	ZF/ZS/J06 078	89	59	42	1,090 ¹	6.5		10
	ZH/ZL/J06 078	89	59	42	910	6.5		Interpolated
	ZJ/ZW/J06 078	89	59	51	1,030	6.5		Interpolated
	ZR/ZK/J06 078	89	59	51	1,050 ¹	6.5		5
	ZT/ZV/J06 090	89	59	42	860	7.5		Interpolated
	ZH/ZL/J07 090	89	59	42	910	7.5		Interpolated
	ZJ/ZW/J07 090	89	59	51	1,081	7.5		Interpolated
	XF/XA/J07 090	89	59	42	920	7.5		Interpolated
	ZR/ZK/J07 090	89	59	42	965	7.5		Interpolated
	ZT/ZV/J08 102	89	59	51	1,020	8.5		Interpolated
	ZH/ZL/J08 102	89	59	51	1,030	8.5		Interpolated
	ZJ/ZW/J08 102	89	59	51	1,135	8.5		Interpolated
	ZR/ZK/J08 102	89	59	51	1,200	8.5		Interpolated
	ZF/ZS/J10 120	89	59	51	1,050	10		Interpolated
	ZH/ZL/J10 120	89	59	51	1,090	10		Interpolated
	ZJ/ZW/J10 120	89	59	51	1,070	10		Interpolated
	XF/XA/J10 120	89	59	51	1,135	10		Interpolated
	ZR/ZK/J10 120	89	59	51	1,200	10		Interpolated
	ZT/ZV/J12 150	119.5	59	51	1,253	12.5		Interpolated
	ZH/ZL/J12 150	119.5	59	51	1,250 ¹	12.5		11
XF/XA/J12 150	119.5	59	51	1,510 ¹	12.5	8		
ZJ/ZW/J12 150	119.5	59	51	1,570 ¹	12.5	9		
ZR/ZK/J12 150	119.5	59	51	1,500 ¹	12.5	6		
Precorator Air Handling Units (Ultra High Efficiency)	ZJ/ZV 120	119.5	59	51	1,470 ¹	10	2.0	12
	ZT/ZV 078	119.5	59	51	1,550	6.5		Interpolated
	ZT/ZV 090	119.5	59	51	1,550	7.5		Interpolated
	ZT/ZV 102	119.5	59	51	1,575	8.5		Interpolated
	ZT/ZV 150	119.5	59	51	1,840 ¹	12.5	13	

1. Weights listed for tested units are actual, not approximate weights. The weights listed for interpolated units are maximum weights, assuming all optional features are included. Optional features are summarized in the table below.

2. Model numbers are generalized for each type of unit and the associated BTU tonnage that the unit can output.

Unit Accessory	Operating Weight (lbs.)
Economizer	85
Power Exhaust	35
Electric Heat	49
Gas Heat	110
Variable Frequency Drive	30

1. Weight given is for the maximum electric heater size available.

2. Weight given for the gas heater is for the maximum number of tube heat exchangers available (8 tube).

3. Weight includes mounting hardware, controls and manual bypass option.

Single Package R-410A Air Conditioner

Project Name: **Sierra - Evansville, IN**
REV 1

Unit Model #: **ZT037N08P4B5HCA1R3**

Quantity: **3** Tag #: **RTU-6,7,9**

1RC0471 Roof Curb

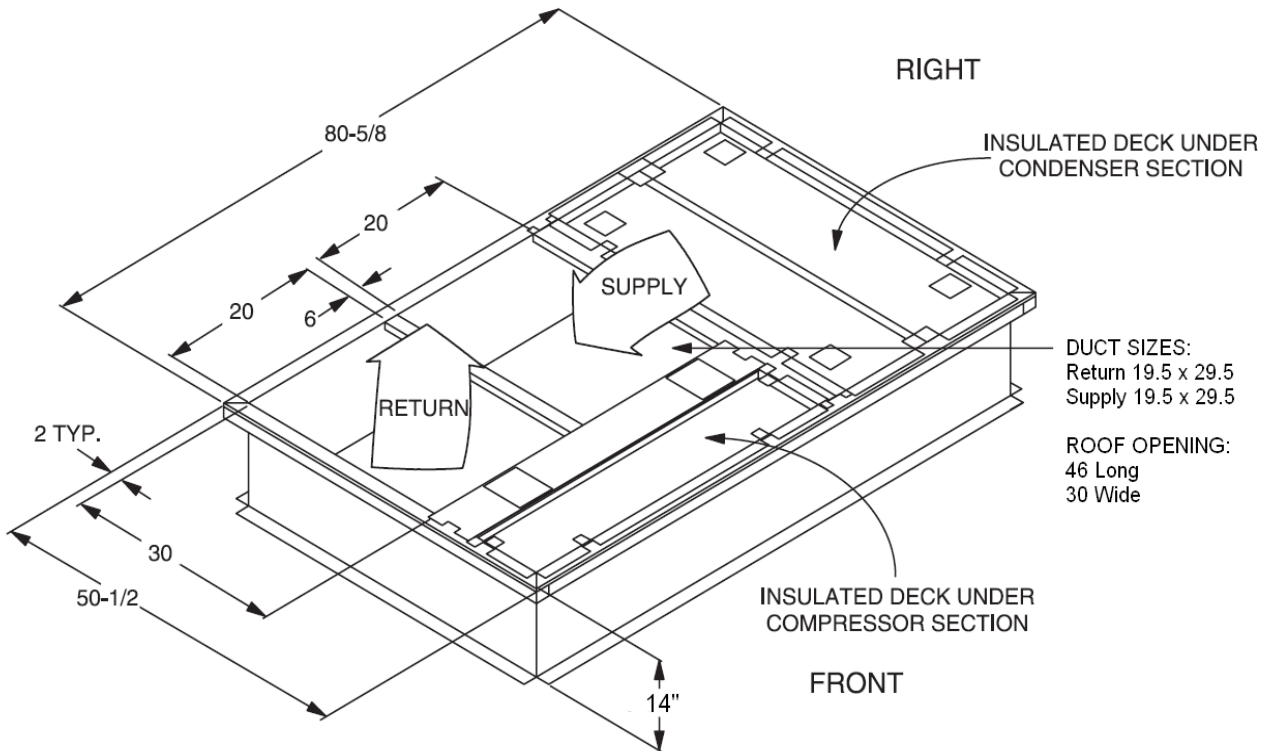

DUCT SIZES:
 Return 19.5 x 29.5
 Supply 19.5 x 29.5

ROOF OPENING:
 46 Long
 30 Wide

* Supply and Return Air (Including duct support rails) as shown, are typical for bottom duct applications.
 For location of horizontal duct applications (On rear of unit), refer to Unit Dimensions details.

1RC0471 Roof Curb Dimensions

Single Package R-410A Air Conditioner

 Project Name: **Sierra - Evansville, IN REV 1**

 Unit Model #: **ZJ150N24R4D5HCA1R2**

 Quantity: 1 **Tag #: RTU-8**

 System: **ZJ150N24R4D5HCA1R2**

Cooling Performance

Total gross capacity	170.8 MBH
Sensible gross capacity	121.3 MBH
Total net capacity	155.7 MBH
Sensible net capacity	106.2 MBH
Efficiency (at ARI)	12.00 EER
Integrated eff. (at ARI)	15.20 IEER
Ambient DB temp.	95.0 °F
Entering DB temp.	80.0 °F
Entering WB temp.	67.0 °F
Evap Coil Leaving DB temp.	57.5 °F
Evap Coil Leaving WB temp.	56.1 °F
Unit Leaving DB temp.	60.3 °F
Unit Leaving WB temp.	57.2 °F
Leaving air temp dew point	55.20 °F
Power input (w/o blower)	11.50 kW
Sound power	82 dB(a)

Refrigerant

Refrigerant type	R-410A
Sys1	10 lb 8 oz
Sys2	9 lb 12 oz

Gas Heating Performance

Entering DB temp.	60 °F
Heating output capacity (Max)	194.0 MBH
Supply air	5000 cfm
Heating input capacity (Max)	240 MBH
Leaving DB temp.	95.9 °F
Air temp. rise	35.9 °F
SSE	81.0 %
Stages	2

Supply Air Blower Performance

Supply air	5000 cfm
Ext. static pressure	0.6 IWG
Addl. Unit Losses (Options/Accessories)	0.82 IWG
Blower speed	1463 rpm
Max BHP of Motor (including service factor)	5.75 HP
Duct location	Bottom
Motor rating	5.00 HP
Actual required BHP	4.75 HP
Power input	4.43 kW
Elevation	0 ft
Drive type	BELT
Requires field-supplied drive	true

Electrical Data

Power supply	460-3-60
Unit min circuit ampacity	40.7 A
Unit max over-current protection	50 A

Dimensions & Weight

Hgt 51 in	Len 120 in	Wth 59 in
Weight with factory installed options 1650 lb		

Clearances

Right	12 in	Front	48 in	Rear	36 in
Top	72 in	Bottom	0 in	Left	36 in

Note: Please refer to the tech guide for listed maximum static pressures

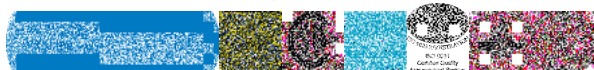

12.5 Ton

- York Sun Pro units are manufactured at an ISO 9001 registered facility and each rooftop is completely computer-run tested prior to shipment.

Unit Features

- Two Stage Cooling
- 240 MBH Input Aluminized Steel, Two Stage Gas Heat
- Full perimeter base rails with built in rigging capabilities
- Unit Cabinet Constructed of Powder Painted Steel, Certified At 750 Hours Salt Spray Test (ASTM B-117 Standards)
- Scroll Compressor[s]
- Dry Bulb Low Leak Economizer w/Barometric Relief and Power Exhaust and Hoods (Bottom or Horizontal End Return Only) with Economizer Fault Detection & Diagnostic (Meets ASHRAE 90.1-2013, IECC 2015, California Title 24, AMCA 511).
- Slide-Out Blower/5 HP Belt Drive Motor Assembly
- Solid Core Liquid Line Filter Driers
- Unit Ships with 2" Throwaway Filters
- Replacement Filters: 4 - (24" x 20"). Unit accepts 2" or 4" wide filters.
- Non-Powered Convenience Outlet
- HACR Circuit Breaker/Disconnect
- Single Point Power Connection
- Through-the-Curb and Through-the-Base Utility Connections
- Short Circuit Current: 5kA RMS Symmetrical
- Return Air Smoke Detector
- Micro-Channel "all-aluminum" condenser coil, Copper tube/aluminum fin evaporator coil
- Composite Drain Pan - Back Connection
- Tool-free maintenance with features like hinged doors for all-access panels, slide-out blower and blower motor tray

BAS Controller

- IntelliSpeed control of the VFD based on stages of cooling. Provides Single Zone VAV Fan Operation as defined by ASHRAE 90.1 section 6.4.3.10.
- Smart Equipment Controller including Discharge Air, Return Air, and Outdoor Air Temperature Sensors. BACNet MS/TP, Modbus and N2 communication card.

Standard Unit Controller: Smart Equipment Control Board

- Safety Monitoring - Monitors the High and Low-Pressure Switches, the Freezestats, the Gas Valve, if Applicable, and the Temperature Limit Switch on Gas and Electric Heat Units. The Unit Control Board will Alarm on Ignition Failures, Safety Lockouts and Repeated Limit Switch Trips.

Warranty

- One (1) Year Limited Warranty on the Complete Unit
- Five (5) Year Warranty - Compressors and Electric Heater Elements
- Ten (10) Year Limited Warranty - Aluminized Steel Heat Exchanger



York® Sun™ Pro 3-12.5 Ton Package

Single Package R-410A Air Conditioner

Project Name: **Sierra - Evansville, IN REV 1**

Unit Model #: **ZJ150N24R4D5HCA1R2**

Quantity: **1** Tag #: **RTU-8**

System: **ZJ150N24R4D5HCA1R2**

Additional Electrical Data

Power supply	460-3-60
Unit min circuit ampacity	40.7 A
Unit max over-current protection	50 A
Min Voltage	432 V
Max Voltage	504 V
Comp #1 RLA	12.2
Comp #1 LRA	87.0
Comp #2 RLA	12.2
Comp #2 LRA	87
Indoor Mtr Voltage	460-3-60
Indoor Mtr FLA	6.6
Outdoor Mtr Qty	4
Outdoor Fan Voltage	460-1-60
OD Fan Mtr FLA (ea.)	1.1
Power Ex Mtr Qty (if applicable)	1
Powered Ex Voltage(if applicable)	460-1-60
Power Ex Mtr FLA (ea) (if applicable)	2.2
Combustion Mtr Qty	1
Combustion Motor Voltage	208/230-1-60
Combustion Mtr FLA (ea)	0.5



York® Sun™ Pro 3-12.5 Ton Package

Single Package R-410A Air Conditioner

Project Name: Sierra - Evansville, IN REV 1

Unit Model #: ZJ150N24R4D5HCA1R2

Quantity: 1 Tag #: RTU-8

System: ZJ150N24R4D5HCA1R2

Factory Installed Options

ZJ150N24R4D5HCA1R2

Equipment Options	Option(s) Selected	
Product Category:	ZJ	Single Packaged R-410A Air Conditioner, High Efficiency 12.0 EER
Nominal Cooling Capacity:	150	12.5 Ton Two Stage Cooling
Heat Type and Nominal Heat Capacity:	N24	240 MBH Input Aluminized Steel, Two Stage Gas Heat
Blower Option:	R	5 HP High Static Belt Drive Blower IntelliSpeed control of the VFD based on stages of cooling (Provides Single Zone VAV Fan Operation as defined by ASHRAE 90.1 section 6.4.3.10)
Voltage:	4	460-3-60
Outside Air Option:	D	Dry Bulb Low Leak Economizer w/Barometric Relief and Power Exhaust and Hoods (Bottom or Horizontal End Return Only) with Economizer Fault Detection & Diagnostic (Meets ASHRAE 90.1-2013, IECC 2015, California Title 24, AMCA 511).
Service Options:	5	Non-Powered Convenience Outlet HACR Circuit Breaker/Disconnect
Sensor Options:	H	Return Air Smoke Detector (Bottom return only)
Controls:	C	Smart Equipment Controller including Discharge Air, Return Air, and Outdoor Air Temperature Sensors. BACNet MS/TP, Modbus and N2 Communication Card.
Refrigeration:	A	Micro-Channel "all-aluminum" condenser coil, Copper tube/aluminum fin evaporator coil
Additional Options:	1	Standard 2" Throwaway Filters Phase Monitor
Cabinet Options:	R	Composite Drain Pan - Back Connection Tool-free maintenance with features like hinged doors for all-access panels, slide-out blower and blower motor tray
Product Generation:	2	

Field Installed Accessories



York® Sun™ Pro 3-12.5 Ton Package

Single Package R-410A Air Conditioner

Project Name: **Sierra - Evansville, IN REV 1**

Unit Model #: **ZJ150N24R4D5HCA1R2**

Quantity: **1** Tag #: **RTU-8**

System: **ZJ150N24R4D5HCA1R2**

- 1RC0471 - Roof Curb - 14" High, Flat, Uninsulated, Full Perimeter (Shipped Knocked Down) (135.0 lbs)
- 2EC0401 - Kit, Single Enthalpy Field Installed (1.0 lbs)
- 1BD0408 - Burglar Bars (32.0 lbs)
- 1HG0441 - Hail Guard Kit-Diamond Pattern (44.0 lbs)

Single Package R-410A Air Conditioner

 Project Name: **Sierra - Evansville, IN**
REV 1

 Unit Model #: **ZJ150N24R4D5HCA1R2**

 Quantity: 1 Tag #: **RTU-8**

Component Locations

Cooling With Gas Heat (6.5 Through 10 Tons)

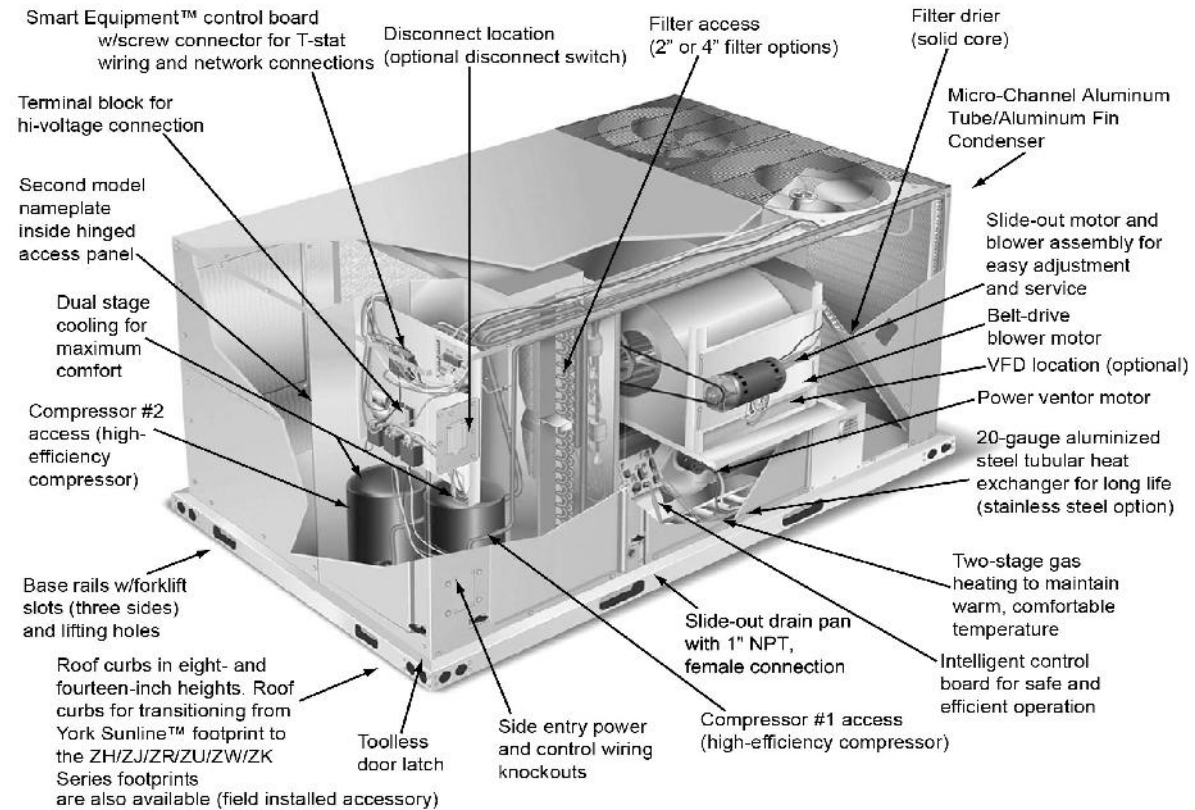

Project Name: **Sierra - Evansville, IN REV 1**

 Unit Model #: **ZJ150N24R4D5HCA1R2**

 Quantity: **1** Tag #: **RTU-8**

Unit Dimensions

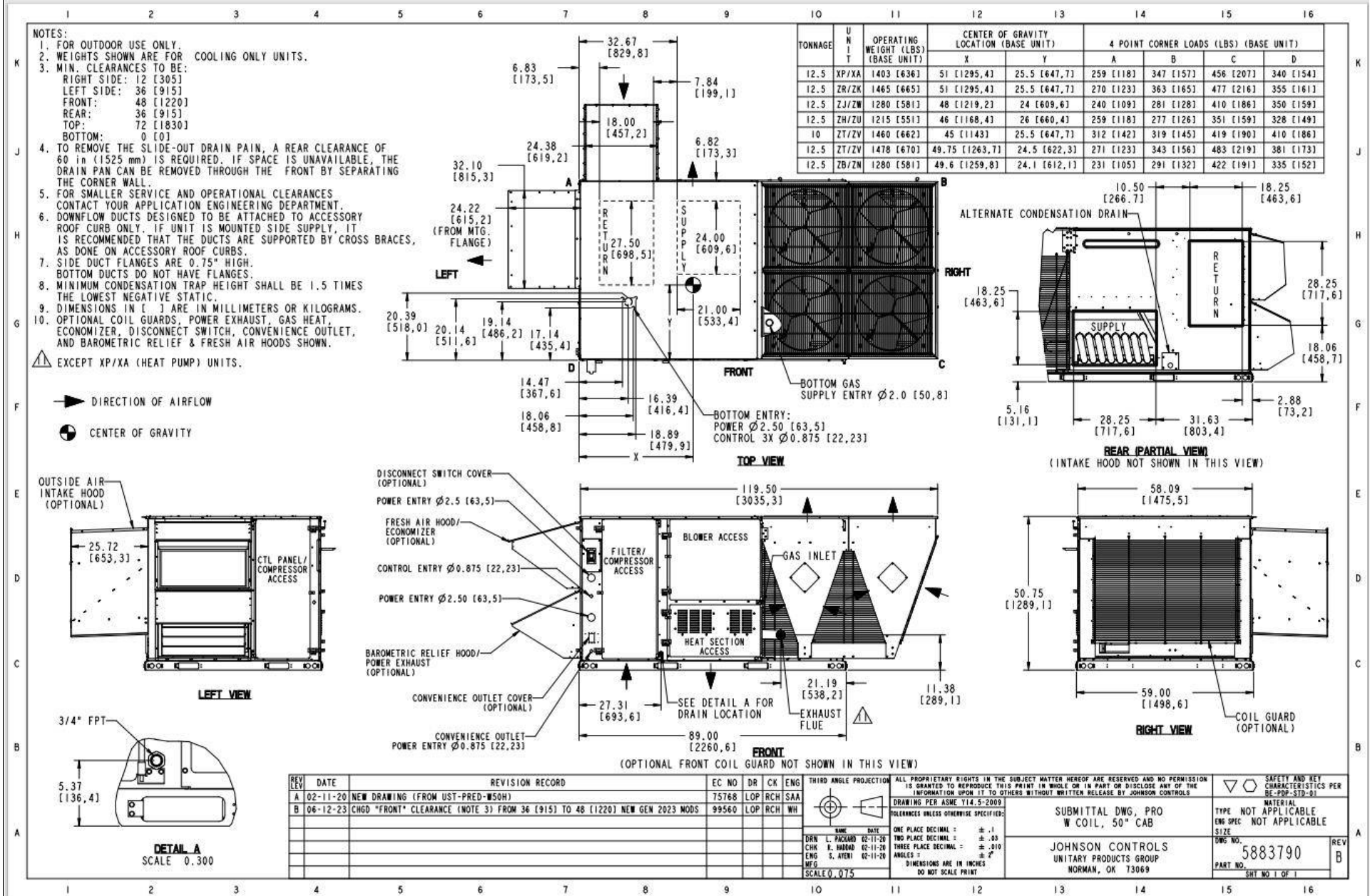

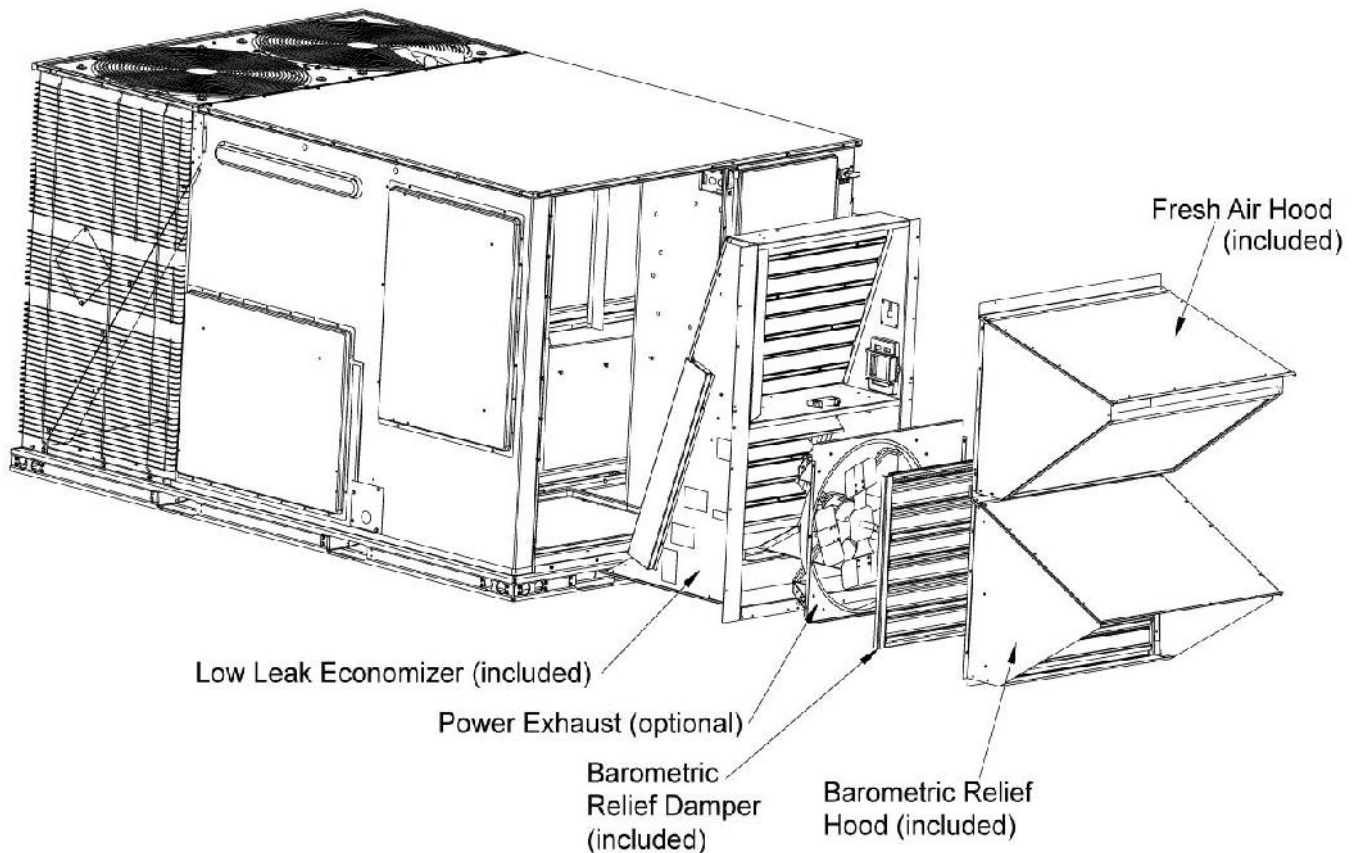
Single Package R-410A Air ConditionerProject Name: **Sierra - Evansville, IN**
REV 1Unit Model #: **ZJ150N24R4D5HCA1R2**Quantity: 1 Tag #: **RTU-8****Low Leak Downflow Economizer****Low Leak Downflow Economizer (shown with optional Power Exhaust)**

Low leak economizers are capable achieving low leakage rates of 3 cfm/sq. ft at 1" of static pressure, meeting or exceeding the following standards:

- ASHRAE 90.1-2010
- ASHRAE 62
- AMCA 511 (licensed as Class 1A damper)
- International Energy Conservation Code (IECC)
- California Title 24

The outdoor intake opening shall be covered with a rain hood that matches the exterior of the unit. Water eliminator/filters shall be provided.

Simultaneous economizer/compressor operation is also possible. Dampers shall fully close on power loss.

Single Package R-410A Air Conditioner

Project Name: **Sierra - Evansville, IN**
REV 1

Unit Model #: **ZJ150N24R4D5HCA1R2**

Quantity: 1 Tag #: **RTU-8**

Factory Installed Power Exhaust

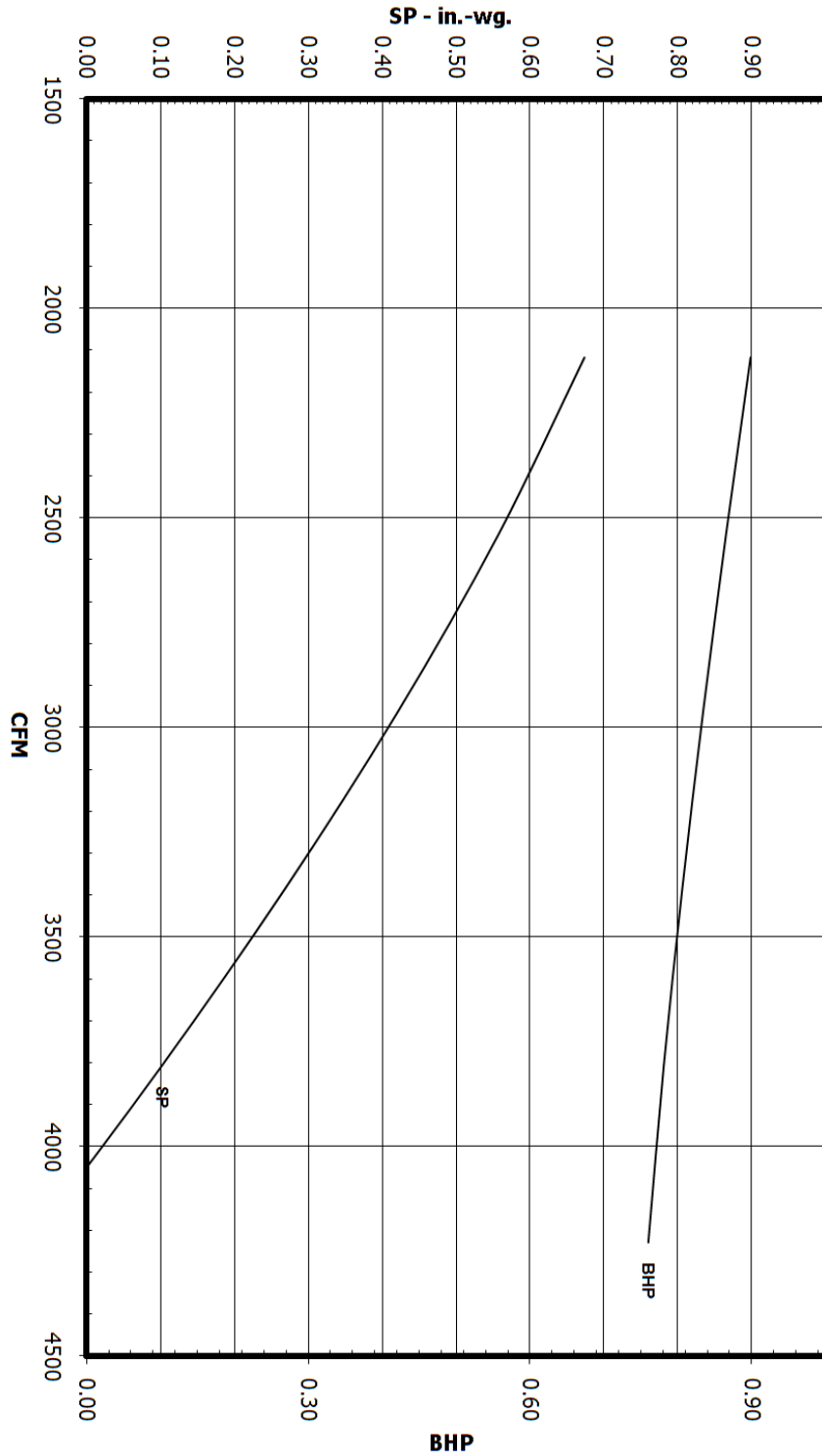

**3-12.5 Ton
 Power Exhaust
 Fan Curve**

Single Package R-410A Air Conditioner

Project Name: **Sierra - Evansville, IN**
REV 1Unit Model #: **ZJ150N24R4D5HCA1R2**Quantity: 1 Tag #: **RTU-8**

Seismic Certification

**OFFICE OF STATEWIDE HEALTH PLANNING AND DEVELOPMENT
FACILITIES DEVELOPMENT DIVISION**

APPLICATION FOR OSHPD SPECIAL SEISMIC CERTIFICATION PREAPPROVAL (OSP)

OFFICE USE ONLY

APPLICATION #: **OSP - 0213**

OSHPD Special Seismic Certification Preapproval (OSP)

Type: New Renewal

Manufacturer Information

Manufacturer: Johnson Controls Inc. (JCI)Manufacturer's Technical Representative: Cameron Boyce, Engineer IIMailing Address: 5005 Interstate Drive, Norman, OK, 73069Telephone: (405) 419-6830Email: cameron.w.boyce@jci.com

Product Information

Product Name: Predator Rooftop Air Conditioning UnitsProduct Type: Packaged Air Conditioning Units OSP-0213Product Model Number: See attached

(List all unique product identification numbers and/or part numbers)

General Description: The units are enclosures with the following subcomponents: refrigerant compressors, outdoor fan motors, indoor coils, outdoor coils, reversing valve with coil, thermostatic expansion valves, standard indoor blower motor, Variable frequency drive indoor blower motor, exhaust fan motor, variable frequency drive, economizer, electric heater, heat cells, filters, and other miscellaneous items included in the subcomponent tables.Mounting Description: Units are rigid curb and isolated curb base mounted

Applicant Information

Applicant Company Name: The VMC GroupContact Person: John GiulianoMailing Address: 113 Main Street, Bloomingdale, NJ 07403Telephone: (973) 838-1780Email: john.giuliano@thvmcgroup.com

I hereby agree to reimburse the Office of Statewide Health Planning and Development review fees in accordance with the California Administrative Code, 2016.

Signature of Applicant: Date: 8/28/19Title: PresidentCompany Name: The VMC Group

*Access to Safe, Quality Healthcare Environments that Meet California's Diverse

STATE OF CALIFORNIA - HEALTH AND HUMAN SERVICES AGENCY
OSH-FD-759 (REV 12/16/15)

Page 1 of 3

Single Package R-410A Air Conditioner

Project Name: **Sierra - Evansville, IN**
REV 1Unit Model #: **ZJ150N24R4D5HCA1R2**Quantity: 1 Tag #: **RTU-8**

Seismic Certification



OFFICE OF STATEWIDE HEALTH PLANNING AND DEVELOPMENT FACILITIES DEVELOPMENT DIVISION

California Licensed Structural Engineer Responsible for the Engineering and Test Report(s)

Company Name: The VMC GroupName: Kenneth Tarlow California License Number: SE-2851Mailing Address: 113 Main Street, Bloomingdale, NJ 07403Telephone: (973) 838-1780 Email: ken.tarlow@thevmcgroup.com

Supports and Attachments Preapproval

- Supports and attachments are preapproved under OPM- _____
(Separate application for OSHPD Preapproval of Manufacturer's Certification (OPM) of Supports and attachments is required)
- Supports and attachments are not preapproved

Certification Method

- Testing in accordance with: ICC-ES AC156
- Other (Please Specify): _____

Testing Laboratory

Company Name: DCL LabsContact Name: Josh Sailer, Laboratory ManagerMailing Address: 1315 Greg Street, Suite 109, Sparks, NV 89431Telephone: (775) 358-5085 Email: josh@shaketest.com

*Access to Safe, Quality Healthcare Environments that Meet California's Diverse

STATE OF CALIFORNIA – HEALTH AND HUMAN SERVICES AGENCY
OSH-FD-759 (REV 12/16/15)

Page 2 of 3

Single Package R-410A Air Conditioner

Project Name: **Sierra - Evansville, IN**
REV 1Unit Model #: **ZJ150N24R4D5HCA1R2**Quantity: 1 Tag #: **RTU-8**

Seismic Certification



OFFICE OF STATEWIDE HEALTH PLANNING AND DEVELOPMENT FACILITIES DEVELOPMENT DIVISION

Seismic Parameters

Design in accordance with ASCE 7-16 Chapter 13: Yes NoDesign Basis of Equipment or Components (F_p/W_p) = Rigid Curb = 1.5; Spring Isolated Curb = 4.5 S_{DS} (Design spectral response acceleration at short period, g) = 2.00 a_p (In-structure equipment or component amplification factor) = 2.5 R_p (Equipment or component response modification factor) = Rigid Curb = 6.0; Spring Isolated Curb = 2.0 Ω_0 (System overstrength factor) = 2.0 I_p (Importance factor) = 1.5 z/h (Height factor ratio) = 1Equipment or Component Natural Frequencies (Hz) = See attachmentOverall dimensions and weight (or range thereof) = See attachmentEquipment or Components @ grade designed in accordance with ASCE 7-16 Chapter 15: Yes NoDesign Basis of Equipment or Components (V/W) = _____ S_{DS} (Design spectral response acceleration at short period, g) = _____ S_{D1} (Design spectral response acceleration at 1 second period, g) = _____ R (Response modification coefficient) = _____ Ω_0 (System overstrength factor) = _____ C_n (Deflection amplification factor) = _____ I_p (Importance factor) = 1.5

Height to Center of Gravity above base = _____

Equipment or Component Natural Frequencies (Hz) = _____

Overall dimensions and weight (or range thereof) = _____

Tank(s) designed in accordance with ASME BPVC, 2015: Yes No

List of Attachments Supporting Special Seismic Certification

 Test Report(s) Drawings Calculations Manufacturer's Catalog Other(s) (Please Specify): _____

OSHPD Approval (For Office Use Only) – Approval Expires on December 31, 2025

Signature:  Date: March 8, 2021Print Name: Timothy J. Piland Title: SSESpecial Seismic Certification Valid Up to: S_{DS} (g) = 2.00 z/h = 1

Condition of Approval (if applicable): _____

*Access to Safe, Quality Healthcare Environments that Meet California's Diverse

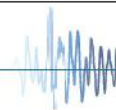
STATE OF CALIFORNIA – HEALTH AND HUMAN SERVICES AGENCY
OSH-FD-759 (REV 12/16/15)

Page 3 of 3

Single Package R-410A Air Conditioner

 Project Name: **Sierra - Evansville, IN**
 REV 1

 Unit Model #: **ZJ150N24R4D5HCA1R2**

 Quantity: 1 Tag #: **RTU-8**

Seismic Certification

Table 1 - Certified Components

 Manufacturer: Johnson Controls and other Unitary Product Group brands (York, Coleman, Luxaire, Evcon, Fraser-Johnston and Ready Ship)
 Product Line: JCI Packaged Rooftop Units

Product Construction: Cabinet's constructed of G90 galvanized 1,000 hour salt spray (per ASTM B117) rated powder coated 20 gage carbon steel wrapper and duct panel with integral corner posts, all attached at the base to four (4) full perimeter 14 gage base rails with 410 sheet metal screws.

Options: 230-575 V, economizer, power exhaust, electric or gas heater, variable frequency drive

Mounting Description: Rigid or Flexible Curb Mounting

Product Line	Model Number ²	Dimensions (inches)			Operating Weight (lb)	Nominal Cooling Capacity (Tons)	5dks (g), z/h=1	Unit
		Depth	Width	Height				
Precorator Air Handling Units (Short)	ZH/ZU/JA3 037	89	59	42	860 ¹	3	2.0	3
	ZJ/ZW/JA3 037	89	59	42	740	3		Interpolated
	ZR/ZK/JA3 037	89	59	42	980 ¹	3		1
	ZT/ZV/JA3 037	89	59	42	927	3		Interpolated
	ZH/ZU/JA4 049	89	59	42	763	4		Interpolated
	ZJ/ZW/JA4 049	89	59	42	762	4		Interpolated
	ZR/ZK/JA4 049	89	59	42	880	4		Interpolated
	ZT/ZV/JA4 049	89	59	42	960	4		Interpolated
	ZI/ZV/JA5 061	89	59	42	777	5		Interpolated
	ZJ/ZW/JA5 061	89	59	42	1,070 ¹	5		4
	ZR/ZK/JA5 061	89	59	42	1,070 ¹	5		7
ZT/ZV/JA5 061	89	59	42	968	5	Extrapolated		
Precorator Air Handling Units (Standard)	XF/XA/J06 078	89	59	42	970 ¹	6.5	2.0	7
	ZF/ZS/J06 078	89	59	42	1,090 ¹	6.5		10
	ZH/ZL/J06 078	89	59	42	910	6.5		Interpolated
	ZI/ZV/J06 078	89	59	51	1,030	6.5		Interpolated
	ZJ/ZW/J06 078	89	59	51	1,050 ¹	6.5		5
	ZR/ZK/J06 078	89	59	42	860	7.5		Interpolated
	ZT/ZV/J06 078	89	59	42	910	7.5		Interpolated
	ZI/ZW/J07 090	89	59	51	1,081	7.5		Interpolated
	ZJ/ZW/J07 090	89	59	42	920	7.5		Interpolated
	ZR/ZK/J07 090	89	59	42	965	7.5		Interpolated
	ZT/ZV/J07 090	89	59	51	1,020	8.5		Interpolated
	ZH/ZL/J08 102	89	59	51	1,030	8.5		Interpolated
	ZI/ZV/J08 102	89	59	51	1,050 ¹	8.5		Interpolated
	ZJ/ZW/J08 102	89	59	51	1,135	8.5		Interpolated
	ZR/ZK/J08 102	89	59	51	1,200	8.5		Interpolated
	ZF/ZS/J10 120	89	59	51	1,050	10		Interpolated
	ZH/ZL/J10 120	89	59	51	1,090	10		Interpolated
	ZI/ZV/J10 120	89	59	51	1,070	10		Interpolated
	ZJ/ZW/J10 120	89	59	51	1,135	10		Interpolated
	ZR/ZK/J10 120	89	59	51	1,200	10		Interpolated
	ZT/ZV/J11 150	119.5	59	51	1,253	12.5		Interpolated
ZH/ZL/J12 150	119.5	59	51	1,250 ¹	12.5	11		
XF/XA/J12 150	119.5	59	51	1,510 ¹	12.5	8		
ZI/ZV/J12 150	119.5	59	51	1,570 ¹	12.5	9		
ZR/ZK/J12 150	119.5	59	51	1,500 ¹	12.5	6		
Precorator Air Handling Units (Ultra High Efficiency)	ZI/ZV 120	119.5	59	51	1,470 ¹	10	2.0	12
	ZT/ZV 078	119.5	59	51	1,550	6.5		Interpolated
	ZT/ZV 090	119.5	59	51	1,550	7.5		Interpolated
	ZT/ZV 102	119.5	59	51	1,575	8.5		Interpolated
	ZT/ZV 150	119.5	59	51	1,880 ¹	12.5	13	

 1. Weights listed for tested units are actual, not approximate weights. The weights listed for interpolated units are maximum weights, assuming all optional features are included. Optional features are summarized in the table below.
 2. Model numbers are generalized for each type of unit and the associated BTU tonnage that the unit can output.

Unit Accessory	Operating Weight (lbs.)
Economizer	85
Power Exhaust	35
Electric Heat	49
Gas Heat	110
Variable Frequency Drive	30

- Weight given is for the maximum electric heater size available.
- Weight given for the gas heater is for the maximum number of tube heat exchangers available (8 tube).
- Weight includes mounting hardware, controls and manual bypass option.

Single Package R-410A Air Conditioner

Project Name: **Sierra - Evansville, IN**
REV 1

Unit Model #: **ZJ150N24R4D5HCA1R2**

Quantity: **1** Tag #: **RTU-8**

1RC0471 Roof Curb

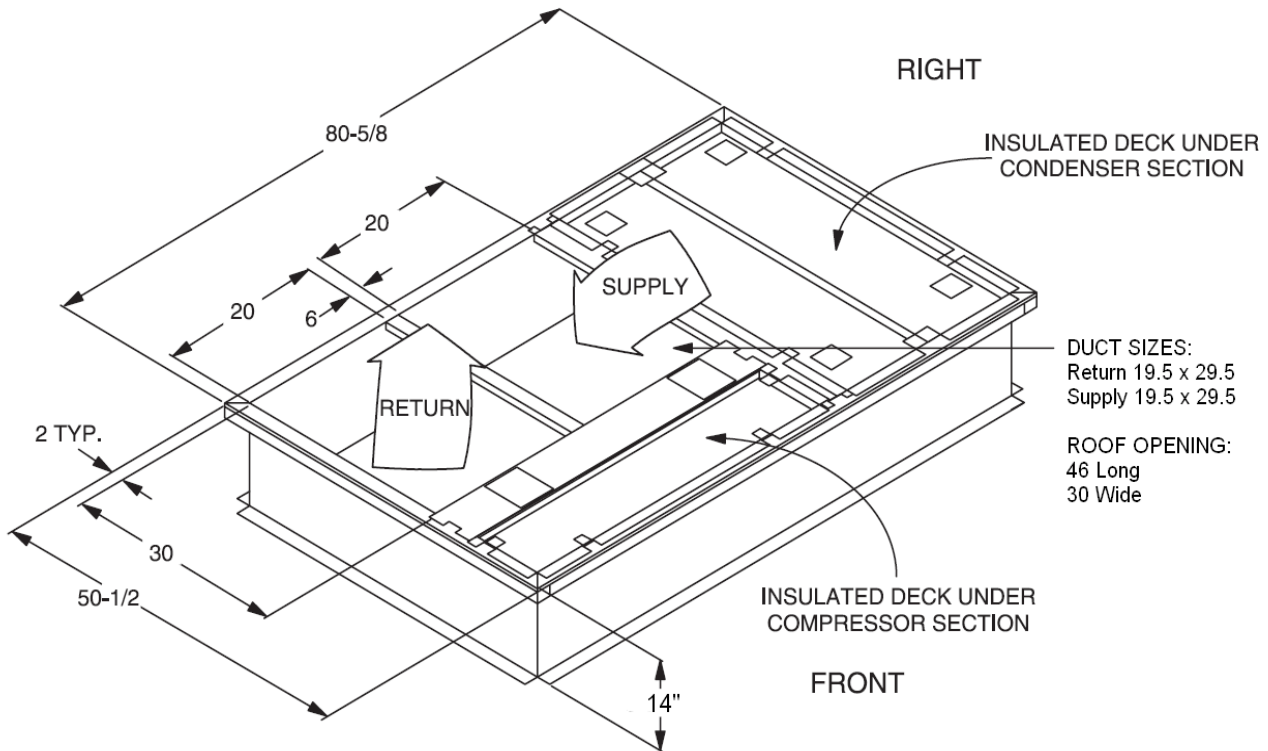

DUCT SIZES:
 Return 19.5 x 29.5
 Supply 19.5 x 29.5

ROOF OPENING:
 46 Long
 30 Wide

* Supply and Return Air (Including duct support rails) as shown, are typical for bottom duct applications.
 For location of horizontal duct applications (On rear of unit), refer to Unit Dimensions details.

1RC0471 Roof Curb Dimensions

Date

12/09/2023

Project Name

Sierra - Evansville, IN REV 1

Project Number

Client / Purchaser

Guide Specification Summary Page

Product Series	Models and Unit Tags	
York® Sun™ Pro 3-12.5 Ton Package	ZJ120N24R4D5HCA1R3	RTU-1
	ZJ078N18R4D5HCA1R3	RTU-2,3,5
	ZJ090N18R4D5HCA1R3	RTU-4
	ZT037N08P4B5HCA1R3	RTU-6,7,9
	ZJ150N24R4D5HCA1R2	RTU-8

GENERAL

York® Sun™ Pro units are convertible single packages with a common footprint cabinet and common roof curb for all 3 through 12-1/2 ton models. All 6-1/2 through 12-1/2 ton have two compressors with independent R-410A refrigeration circuits to provide 2 stages of cooling. The units were designed for light commercial applications and can be easily installed on a roof curb, slab, or frame. All units are self contained and assembled on rigid full perimeter base rails allowing for 3-way forklift access and overhead rigging. Every unit is completely charged with R-410A, wired, piped, and tested at the factory to provide a quick and easy field installation. All units are convertible between side and down airflow. Independent economizer designs are used on side and down discharge applications, as well as all tonnage sizes. Predator® units are available in the following configurations: cooling only, cooling with electric heat, cooling with gas heat, reheat only, reheat with electric heat and reheat with gas heat. Electric heaters are available as factory-installed options or field-installed accessories.

DESCRIPTION

Units shall be factory assembled, single package, (Elec/Elec, Gas/ Elec), designed for outdoor installation. They shall have built in field convertible duct connections for down discharge supply/return or horizontal discharge supply/return and be available with factory installed options or field installed accessories. The units shall be factory wired, piped and charged with R-410A refrigerant and factory tested prior to shipment. All unit wiring shall be both numbered and color coded. The cooling performance shall be rated in accordance with DOE and AHRI test procedures. Units shall be CSA certified to ANSI Z21.47 and UL 1995/CAN/CSA No. 236-M90 standards.

UNIT CABINET

Unit cabinet shall be constructed of galvanized steel with exterior surfaces coated with a non-chalking, powder paint finish, certified at a 750-hour salt spray test per ASTM-B117 standards. Indoor blower sections shall be insulated with up to 1" thick insulation coated on the airside. Either aluminum foil faced or elastometric rubber insulation shall be used in the unit's compartments and be fastened to prevent insulation from entering the air stream. Cabinet doors shall be hinged with toolless access for easy servicing and maintenance. Full perimeter base rails shall be provided to assure reliable transit of equipment, overhead rigging, fork truck access and proper sealing on roof curb applications. Disposable 2" filters shall be furnished as standard and be accessible through hinged access door. Fan performance measuring ports shall be provided on the outside of the cabinet to allow accurate air measurements of evaporator fan performance without

removing panels or creating bypass of the coils. Condensate pan shall be slide out design, constructed of a non corrosive material, internally sloped and conforming to ASHRAE 62-B9 standards. Condensate connection shall be a minimum of 3/4" I.D. female and be rigid mount connection.

INDOOR (EVAPORATOR) FAN ASSEMBLY

Fan shall be a belt drive assembly and include an adjustable pitch motor pulley. Job site selected brake horsepower shall not exceed the motors nameplate horsepower rating plus the service factor. Units shall be designed to operate within the service factor. Fan wheel shall be double inlet type with forward curve blades, dynamically balanced to operate smoothly throughout the entire range of operation. Airflow design shall be constant volume. Bearings shall be sealed and permanently lubricated for longer life and no maintenance. Entire blower assembly and motor shall be slide out design.

OUTDOOR (CONDENSER) FAN ASSEMBLY

The outdoor fans shall be of the direct drive type, discharge air vertically, have aluminum blades riveted to corrosion resistant steel spider brackets and shall be dynamically balanced for smooth operation. The outdoor fan motors shall have permanently lubricated bearings internally protected against overload conditions and staged independently. A cleaning window shall be provided on two sides of the units for coil cleaning.

REFRIGERANT COMPONENTS

Compressors:

- a. Shall be fully hermetic type, direct drive, internally protected with internal high-pressure relief and over temperature protection. The hermetic motor shall be suction gas cooled and have a voltage range of + or - 10% of the unit nameplate voltage.
- b. Shall have internal spring isolation and sound muffling to minimize vibration and noise, and be externally isolated on a dedicated, independent mounting.

Coils:

- a. Evaporator coils shall have aluminum plate fins mechanically bonded to seamless internally enhanced copper tubes with all joints brazed. Special Phenolic coating shall be available as a factory option.
- b. Evaporator coils shall be of the direct expansion, draw-thru design.
- c. Condenser coils shall have aluminum plate fins mechanically bonded to seamless internally enhanced copper tubes with all joints brazed or Micro-Channel aluminum tube, aluminum fins.
- d. Condenser coils shall be of the draw-thru design.

Refrigerant Circuit and Refrigerant Safety Components shall include:

- a. Independent fixed-orifice or thermally operated expansion devices.
- b. Solid core filter drier/strainer to eliminate any moisture or foreign matter.
- c. Accessible service gage connections on both suction and discharge lines to charge, evacuate, and measure refrigerant pressure during any necessary servicing or troubleshooting, without losing charge.
- d. The 6-1/2 through 12-1/2 ton unit shall have two independent refrigerant circuits, equally split in 50% capacity increments.

Unit Controls:

- a. Unit shall be complete with self-contained low-voltage control circuit protected by a resettable circuit breaker on the 24-volt transformer side.
- b. Unit shall incorporate a lockout circuit which provides reset capability at the space thermostat or base unit should any of the following standard safety devices trip and shut off compressor:
 - Loss-of-charge/Low-pressure switch.
 - High-pressure switch.
 - Freeze condition sensor on evaporator coil. If any of these safety devices trip, the LCD screen will display the alarm message.
- c. Unit shall incorporate "AUTO RESET" compressor over temperature, over current protection.
- d. Unit shall operate with conventional thermostat designs and have a low voltage terminal strip for easy hook-up.
- e. Unit control board shall have on-board diagnostics and fault message display.
- f. Standard controls shall include anti-short cycle and low voltage protection, and permit cooling operation down to a selectable value as low as 0 °F.
- g. Control board shall monitor each refrigerant safety switch independently.

GAS HEATING SECTION

Heat exchanger and exhaust system shall be constructed of aluminized steel, and be designed with induced draft combustion with post purge logic, energy saving direct spark ignition, and redundant main gas valve. The heat exchanger shall be of the tubular type, constructed of T1-40 aluminized steel for corrosion resistance and allowing minimum mixed air entering temperature of 40 °F. Burners shall be of the in-shot type, constructed of aluminum-coated steel. All gas piping shall enter the unit cabinet at a single location, through either the side or bottom, without any field modifications. An integrated control board shall provide timed control of evaporator fan functioning and burner ignition. Heating section shall be provided with the following minimum protection:

- a. Primary and auxiliary high-temperature limit switches.
- b. Induced draft pressure sensor.
- c. Flame roll out switch (manual reset).
- d. Flame proving controls.
- e. All two stage gas units shall have two independent stages of capacity (70% or 75% 1st stage, 100% 2nd stage) 3 through 5 ton and (60% 1st stage, 100% 2nd stage) 6-1/2 through 12-1/2 ton.

UNIT OPERATING CHARACTERISTICS

Unit shall be capable of starting and running at 125 °F outdoor temperature, exceeding maximum load criteria of AHRI Standard 340/360. The compressor, with standard controls, shall be capable of operation down to 0 °F outdoor temperature. Unit shall be provided with fan time delay to prevent cold air delivery before heat exchanger warms up. (Gas heat only)

ELECTRICAL REQUIREMENTS - All unit power wiring shall enter unit cabinet at a single factory provided location and be capable of side or bottom entry to minimize roof penetrations and avoid unit field modifications. Separate side and bottom openings shall be provided for the control wiring.

STANDARD LIMITED WARRANTIES - Compressor – 5 Years, Heat Exchanger – 10 Years, Elect. Heat Elem. – 5 Years, Parts – 1 Year.

FACTORY INSTALLED OPTIONAL OUTDOOR AIR
(Shall be made available by either/or):

- **DRY BULB AUTOMATIC ECONOMIZER** – Outdoor and return air dampers that are interlocked and positioned by a fully-modulating, spring-return damper actuator. The maximum leakage rate for the outdoor air intake dampers shall be designed to meet ASHRAE 90.1, AMCA 511 Class 1A damper, and the International Energy Conservation Code (IECC) certification requirements by achieving leakage rates of 3 CFM/sq. ft. at 1" of static pressure. Changeover from compressor to economizer operation shall be provided by an integral electronic enthalpy control that feeds input into the basic module. The outdoor intake opening shall be covered with a rain hood that matches the exterior of the unit. Water eliminator/filters shall be provided. Simultaneous economizer/compressor operation is also possible. Dampers shall fully close on power loss.

ADDITIONAL FACTORY INSTALLED OPTIONS

- **Alternate Indoor Blower Motor** – For applications with high restrictions, units are available with optional indoor blower motors that provide higher static output and/or higher airflow.
- **IntelliSpeed™ Supply Fan Control Option (ASHRAE 90.1 compliant, section 6.4.3.10)** – Units configured with the IntelliSpeed™ Supply Fan Option will contain a VFD for variable volume supply fan operation. This option allows the supply fan RPM to vary based on the number of compressors or heating stages energized. The economizer's minimum position will also be configurable to vary based on the supply fan VFD frequency output.
- **Non-Powered Convenience Outlet** – Unit is provided with a non-powered 120VAC GFCI outlet with cover on the corner of the unit housing the compressors.
- **BAS Controls** – Include supply air sensor, return air sensor, dirty filter indicator and air proving switch.
- **Smoke Detector** – A smoke detector can be factory mounted and wired in the supply and/or return air compartments.

FIELD INSTALLED OPTIONS

- **Roof Curb** – 14" high, full perimeter knockdown curb, with hinged design for quick assembly.
- **Hail Guard** - This kit includes a sloped hood which installs over the outside condenser coil and prevents damage to the coil fins from hail strikes.
- **Burglar Bars** – Mount in the supply and return openings to prevent entry into the duct work.

Date

12/09/2023

Project Name

Sierra - Evansville, IN REV 1

Project Number

Client / Purchaser

Control Summary Page

Control	Models and Unit Tags	
BACnet MSTP,Mdbs,N2 COM Card	ZJ120N24R4D5HCA1R3	RTU-1
	ZJ078N18R4D5HCA1R3	RTU-2,3,5
	ZJ090N18R4D5HCA1R3	RTU-4
	ZT037N08P4B5HCA1R3	RTU-6,7,9
	ZJ150N24R4D5HCA1R2	RTU-8

23 09 23 Direct- digital Control system for HVAC23 09 23. 13 Decentralized, Rooftop Units:23 09 23. 13.A. Unit Control Board

1. ASHRAE 62- 2001 compliant. BTL certified.
2. Shall accept 20-30 VAC input power, 50/60Hz. 24 VAC nominal.
3. Operating temperature range from -40F to 158F; 10-90% RH (non-condensing UI), and -4F to 158F; 10-90% Rh (non-condensing), with a storage temperature range from -40F to 194F; 5-95% RH (non-condensing).
4. Shall include an option of and Economizer microprocessor controller which communicates directly with the Unit Control Board and has 8 Analog outputs, 2 Analog inputs, 2 Binary outputs, 3 Binary outputs.
5. Controller shall accept the following inputs: space temperature, return air temperature sensor, setpoint adjustment, outdoor air temperature, indoor air quality, outdoor air quality, indoor relative humidity, compressor lock- out, fire/smoke shutdown, single and dual enthalpy, fan status, remote time clock, SA Bus communicated temperature/humidity/CO2 values from Network sensors, FC Bus Network Overrides for space temperature, outdoor air temperature, space humidity, outdoor air quality, Indoor air quality, System purge.
6. Shall accept a single CO2 sensor or multiple CO2 sensors networked together via communication bus in the conditioned space, and be Demand Control Ventilation (DCV) ready.
7. Shall provide the following outputs: economizer, fan, cooling stage 1, cooling stage 2, heat stage 1, heat stage 2, heat stage 3/ exhaust/ reversing valve/ dehumidify/occupied.
8. Unit shall provide surge protection for the controller through a circuit breaker.
9. Shall be Internet capable, and communicate at a Baud rate of 38.4K or faster.
10. Shall have an LED display independently showing the status of activity on the communication bus, and processor operation.
11. Unit shall incorporate a lockout circuit which provides reset capability at the space thermostat or base unit should any of the following standard safety devices trip and shut off compressor. If any of these safety devices trip, the LCD screen will display alarm message indicating the specific safety device that caused the lockout.
 - a. Loss of charge/Low-pressure switch.
 - b. High-pressure switch.
 - c. Freeze condition sensor on evaporator coil.
12. Unit control board must support each usage case:
 - a. Conventional thermostat with low voltage input terminals for easy installation
 - b. Communicating network sensors in the occupied space to provide feedback on space conditions for unit control board to compare with associated setpoints
 - c. Communication via BACnet MS/TP, Modbus RTU, N2 protocols for integration into a building automation/management system
13. Anti-short cycle and low voltage protection features included.
14. Internal occupied/unoccupied scheduling
15. Unit control board shall permit cooling operation down to a selectable value as low as 0 degrees F.
16. Shall allow for start-up, commissioning, troubleshooting, parameter adjustment, setpoint adjustment via onboard display and navigable menu with no additional interface tool or controls technician required.
17. The unit control board shall run a self-test diagnostics algorithm at startup that operated the cooling cycle, heating cycle, fan operation. A status report shall be provided upon completion of the diagnostic self-test.
18. Utilize any wi-fi enabled smart device to access the HVAC or multiple HVAC units if communication wiring between them is present (FC Bus or SA Bus). Remote access shall allow complete ability to perform start-up, commissioning, troubleshooting, parameter adjustment, setpoint adjustment.
19. Local embedded trending and scheduling. Trending data and occupancy scheduling predefined from the factory. Occupancy schedule to be modified via control board joystick menu navigation and remotely using a smart device (cellular phone, laptop, tablet)
20. A menu on the onboard screen shall display the unit status and allow changing parameters where applicable. These include but are not limited to:
 - a. Demand Ventilation Mode – enable or disable
 - b. Operational Setpoint – display current value
 - c. Supply Air Temperature (SAT) – display current value
 - d. Return Air Temperature (RAT) – display current value

- e. Operational Supply Humidity (OprSH) – display current value as provided by a 0-10VDS input, SA Bus Network Sensor, or FC Bus communicated value
 - f. Return Air Humidity (RAH) – display current value
 - g. Operational outdoor Air Temperature (OprOAT) – enthalpy calculated from OAH 0-10VDC input to Economizer board and OprOAT only if economizer is present
 - h. Operational Outdoor Air Humidity (OprOAH) – the buffered outdoor air humidity. May be from economizer boards OAH 0-10VDC input or FC Bus communicated value
 - i. Operational outdoor Air Quality (OprOAQ) – the buffered outdoor air quality in use. May be from economizer boards OAQ 0-10VDC input or FC Bus communicated value
 - j. Operational Indoor Air Quality (OprIAQ) – the buffered indoor air quality in use. May be from economizer board IAQ 0-10VDC input, SA Bus Network Sensor, or FC Bus communicated value
21. A menu shall display and allow modification to the following operations and settings:
- a. HVAC Zone Fan
 - b. Cooling
 - c. Heating
 - d. Economizer
 - e. Demand Ventilation
 - f. Power Exhaust
 - g. Sensors
 - h. Network
22. A menu shall display and allow modification to the following operations and settings:
- a. HVAC Zone – Occupied status
 - b. Indoor Fan status
 - c. Cooling status
 - d. Heating status
 - e. Economizer indication whether free-cooling is available or not
 - f. Enabling or disabling of Demand Ventilation
 - g. Power Exhaust
 - 1) Enable/disable hot-gas reheat if available
 - 2) Warmup/Cooldown
 - 3) Title 24 Load Shed
 - 4) Defrost
23. A menu shall display and allow modification to the following operations and settings:
- a. Firmware version (of UCB, Economizer, other peripheral boards)
 - b. Setting time zone
 - c. Network information
 - 1) Device name that will appear on the FC Bus
 - 2) Selection of communication protocol
 - 3) Operational Baud Rate
 - 4) Device ID
24. A menu shall display and allow modification to the following operations and settings:
- a. Version of firmware
 - b. Ability to Load new firmware
 - c. Create a backup file of the firmware and parameter setting via USB port
 - d. Restore factory default parameter values and setup
 - e. Full and Partial Cloning of parameter setpoints from or to other units
 - f. Data trend exporting
25. A menu shall display and allow modification to the following operations and settings:

- a. Unit serial number, model number and name
- b. Ability to reset Lockouts
- c. Controller name
- d. Displays the current values of all setpoints in use
- e. Displays all current values for the indoor and outdoor zones
- f. Displays current values related to:
 - 1) Indoor Fan
 - 2) Cooling
 - 3) Heating
 - 4) Heat Pump operation
 - 5) Economizer operation
 - 6) Power Exhaust
 - 7) Demand Ventilation
 - 8) Air monitoring station
 - 9) Hot Gas Reheat
 - 10) Smoke Control
- g. Current information for inputs; including
 - 1) Sensors
 - 2) Coil Sensors
 - 3) Thermostat
 - 4) Binary Inputs
 - 5) Unit Protection
 - 6) Network Inputs
 - 7) All outputs (relay and binary)
- h. Self-Test
 - 1) A patented self-test system that runs through a series of algorithms to provide a report of all functioning characteristics of the system at time of startup and commissioning.

23 09 23. 13.B. Auxiliary Control Boards

- 1. ASHRAE 62- 2001 compliant. BTL certified.
- 2. Economizer controller CEC Title 24 Compliant
 - a. Display alarms if the following occur
 - 1) Economizer is economizing when conditions do not support
 - 2) Economizer is not economizing when conditions do support
 - 3) Damper Stuck
 - 4) Excess Outdoor Air
 - 5) Failed Sensor
- 3. Refrigeration Fault Detection & Diagnostics
 - a. There is insufficient refrigerant in any circuit
 - b. There is excessive refrigerant in any circuit
 - c. There is excessive refrigerant flow
 - d. There is insufficient refrigerant flow (restriction)
 - e. Inefficient compressor
 - f. Insufficient High-side heat transfer
 - g. Excessive High-side heat transfer (low ambient control problem, low ΔP)
 - h. Insufficient Low-side heat transfer
 - i. Excessive Low-side heat transfer

- j. Sensor fault- The liquid temperature is greater than the condenser temperature (Could also be triggered if refrigerant level is very low in the system)
- k. Sensor fault- Sensor data is not available
- l. The unit is off
- m. The ambient temperature is too low
- n. The ambient temperature is too high
- o. The return air wet-bulb temperature is too low
- p. The return air wet-bulb temperature is too high
- q. Sensor fault- The condensing temperature is lower than the ambient temperature (Could also be triggered when the condenser is wet)
- r. The suction line temperature is less than the evaporator temperature
- s. The evaporator temperature is greater than the ambient temperature
- t. The liquid temperature is lower than the ambient temperature
- u. Sensor fault- Suction temperature or ambient temperature is invalid
- v. Sensor fault- The return air dry-bulb or wet-bulb temperature is invalid
- w. Sensor fault- The liquid pressure or suction pressure is invalid
- x. Sensor fault- The suction line temperature is invalid
- y. The return air dry-bulb temperature is too low
- z. The return air dry-bulb temperature is too high
- aa. The Efficiency Index is below 75% of ideal
- bb. The Capacity Index is below 75% of ideal

23 09 23. 13.C Remote Accessibility:

1. ASHRAE 62- 2001 compliant. BTL certified.
2. Provide the ability to adjust parameter values, setpoints, limits remotely
3. Connectivity to an Ethernet network via static IP address or Dynamic Name Server (DNS)
4. Allow a maximum of 100 devices on the same FC bus trunk and accessed by one remote device

Start-up sheet

START-UP & SERVICE DATA INSTRUCTION**COMMERCIAL PACKAGE UNITS****3.0 To 50.0 TONS****START-UP CHECKLIST**

Date: _____

Job Name: _____

Customer Name: _____

Address: _____

City: _____ State: _____ Zip: _____

Model Number: _____ Serial Number: _____

Qualified Start-up Technician: _____ Signature: _____

HVAC Contractor: _____ Phone: _____

Address: _____

Contractor's E-mail Address: _____

Electrical Contractor: _____ Phone: _____

Distributor Name: _____ Phone: _____

WARRANTY STATEMENT

Johnson Controls/Ducted Systems is confident that this equipment will operate to the owner's satisfaction if the proper procedures are followed and checks are made at initial start-up. This confidence is supported by the 30 day dealer protection coverage portion of our standard warranty policy which states that Johnson Controls/Ducted Systems will cover parts and labor on new equipment start-up failures that are caused by a defect in factory workmanship or material, for a period of 30 days from installation. Refer to the current standard warranty policy and warranty manual for details.

In the event that communication with Johnson Controls/Ducted Systems is required regarding technical and/or warranty concerns, all parties to the discussion should have a copy of the equipment start-up sheet for reference. A copy of the original start-up sheet should be filed with the Technical Services Department.

The packaged unit is available in constant or variable air volume versions with a large variety of custom options and accessories available. Therefore, some variation in the startup procedure will exist depending upon the products capacity, control system, options and accessories installed.

This start-up sheet covers all startup check points common to all package equipment. In addition it covers essential startup check points for a number of common installation options. Depending upon the particular unit being started not all sections of this startup sheet will apply. Complete those sections applicable and use the notes section to record any additional information pertinent to your particular installation.

Warranty claims are to be made through the distributor from whom the equipment was purchased.

EQUIPMENT STARTUP

Use the local LCD or Mobile Access Portal (MAP) Gateway to complete the start-up.

A copy of the completed start-up sheet should be kept on file by the distributor providing the equipment and a copy sent to:

Johnson Controls/Ducted Systems
 Technical Services Department
 5005 York Drive
 Norman, OK 73069

SAFETY WARNINGS

The inspections and recording of data outlined in this procedure are required for start-up of Johnson Controls/Ducted Systems' packaged products. Industry recognized safety standards and practices must be observed at all times. General industry knowledge and experience are required to assure technician safety. It is the responsibility of the technician to assess all potential dangers and take all steps warranted to perform the work in a safe manner. By addressing those potential dangers, prior to beginning any work, the technician can perform the work in a safe manner with minimal risk of injury.

⚠ WARNING
Lethal voltages are present during some start-up checks. Extreme caution must be used at all times.

⚠ WARNING
Moving parts may be exposed during some startup checks. Extreme caution must be used at all times.

NOTE: Read and review this entire document before beginning any of the startup procedures.

DESIGN APPLICATION INFORMATION

This information will be available from the specifying engineer who selected the equipment. If the system is a VAV system the CFM will be the airflow when the remote VAV boxes are in the

full open position and the frequency drive is operating at 60 HZ. **Do not proceed with the equipment start-up without the design CFM information.**

Design Supply Air CFM: _____ Design Return Air CFM: _____

Design Outdoor Air CFM At Minimum Position: _____

Total External Static Pressure: _____

Supply Static Pressure: _____

Return Static Pressure: _____

Design Building Static Pressure: _____

Outside Air Dilution: Economizer Position Percentage: _____ CFM: _____

Supply Gas Pressure After Regulator W/o Heat Active _____ Inches _____

ADDITIONAL APPLICATION NOTES FROM SPECIFYING ENGINEER:

REFERENCE

General Inspection	Completed	See Notes
Unit inspected for shipping, storage, or rigging damage	<input type="checkbox"/>	<input type="checkbox"/>
Unit installed with proper clearances	<input type="checkbox"/>	<input type="checkbox"/>
Unit installed within slope limitations	<input type="checkbox"/>	<input type="checkbox"/>
Refrigeration system checked for gross leaks (presence of oil)	<input type="checkbox"/>	<input type="checkbox"/>
Terminal screws and wiring connections checked for tightness	<input type="checkbox"/>	<input type="checkbox"/>
Filters installed correctly and clean	<input type="checkbox"/>	<input type="checkbox"/>
Economizer hoods installed in operating position	<input type="checkbox"/>	<input type="checkbox"/>
Condensate drain trapped properly, refer to Installation Manual	<input type="checkbox"/>	<input type="checkbox"/>
Economizer damper linkage tight	<input type="checkbox"/>	<input type="checkbox"/>
Gas Heat vent hood installed	<input type="checkbox"/>	<input type="checkbox"/>
All field wiring (power and control) complete	<input type="checkbox"/>	<input type="checkbox"/>

Air Moving Inspection	Completed	See Notes
Alignment of drive components	<input type="checkbox"/>	<input type="checkbox"/>
Belt tension adjusted properly	<input type="checkbox"/>	<input type="checkbox"/>
Blower pulleys tight on shaft, bearing set screws tight, wheel tight to shaft	<input type="checkbox"/>	<input type="checkbox"/>
Pressure switch or transducer tubing installed properly	<input type="checkbox"/>	<input type="checkbox"/>

Exhaust Inspection Powered <input type="checkbox"/> Barometric Relief <input type="checkbox"/>	Completed	See Notes
Check hub for tightness	<input type="checkbox"/>	<input type="checkbox"/>
Check fan blade for clearance	<input type="checkbox"/>	<input type="checkbox"/>
Check for proper rotation	<input type="checkbox"/>	<input type="checkbox"/>
Check for proper mounting (screen faces towards unit)	<input type="checkbox"/>	<input type="checkbox"/>
Prove operation by increasing minimum setting on economizer	<input type="checkbox"/>	<input type="checkbox"/>

Economizer Inspection Standard <input type="checkbox"/> BAS <input type="checkbox"/>	Completed	See Notes
CO ₂ sensor installed Yes <input type="checkbox"/> No <input type="checkbox"/>	<input type="checkbox"/>	<input type="checkbox"/>
Check economizer setting (Reference Smart Equipment™ Control Board LCD menu location)	<input type="checkbox"/>	<input type="checkbox"/>
Prove economizer open/close through Smart Equipment™ Board Setting	<input type="checkbox"/>	<input type="checkbox"/>

Reheat Mode Normal <input type="checkbox"/> or Alternate <input type="checkbox"/> Not Applicable <input type="checkbox"/>
Humidity Sensor (2SH0401) _____

Operating Measurements - Air Flow

Fan operates with proper rotation (All VFD equipped units with the optional Manual Bypass must be phased for correct blower rotation with the Bypass switch set in the LINE position) ID Fans Exh. Fans Cond. Fans

Pressure drop across dry evaporator coil (At maximum design CFM) ¹	IWC
External Static Pressure	IWC
Return Static Pressure	IWC
Supply Static Pressure	IWC
Supply Air CFM Using Dry Coil Chart	CFM
Final Adjusted Supply Air CFM ²	CFM

1. Consult the proper airflow to pressure drop table to obtain the actual airflow at the measured pressure differential.
2. Was a motor pulley adjustment or change required to obtain the correct airflow?
 Was it necessary to increase or decrease the airflow to meet the design conditions?
 If the motor pulley size was changed, measure the outside diameters of the motor and blower pulleys and record those diameters here:
 Blower Motor HP _____ FLA _____ RPM _____
 Pulley Pitch Diameter _____ Turns Out _____ Final Turns Out _____
 Blower Pulley Pitch Diameter _____ Fixed Sheave _____

ELECTRICAL DATA

T1 - T2 _____ Volts T2 - T3 _____ Volts
 Control Voltage _____ Volts T1 - T3 _____ Volts

Device	Nameplate	Measured List All Three Amperages
Supply Fan Motor ^{1, 2}	AMPS	AMPS
Exhaust Motor (Dampers 100%)	AMPS	AMPS
Condenser Fan #1	AMPS	AMPS
Condenser Fan #2 (if equipped)	AMPS	AMPS
Condenser Fan #3 (if equipped)	AMPS	AMPS
Condenser Fan #4 (if equipped)	AMPS	AMPS
Compressor #1	AMPS	AMPS
Compressor #2 (if equipped)	AMPS	AMPS
Compressor #3 (if equipped)	AMPS	AMPS
Compressor #4 (if equipped)	AMPS	AMPS

1. VAV units with heat section - simulate heat call to drive VAV boxes and VFD/IGV to maximum design airflow position.
2. VAV units without heat section - VAV boxes must be set to maximum design airflow position.

DX13R - SC

Quantity: 1
Special: None

Dimensions

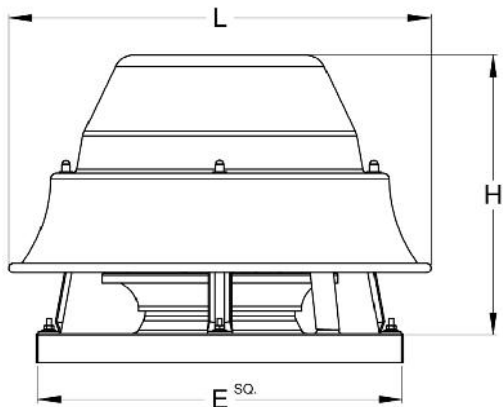

Unit Size	Motor Speed	Motor Efficiency
13	Q - 1550 RPM	S - Standard

E	H	L	Weight
18.5	14.75	21.44	36

Standard Construction Features

- Weatherproof Housing
- Heavy Gauge Spun Aluminum Construction
- Aluminum Centrifugal Fan Wheels Statically & Dynamically balanced
- Spark-resistant, Non-overloading
- Aluminum spun venturis
- Continuous Duty Motors
- AMCA Licensed Ratings Seal for Air & Sound Performance (DX)
- UL and cUL Listed

Accessories

- Temperature: 70
- UL / ETL Listing: 1 - UL 705
- Unit Size: 13
- Drive Type: D - Direct
- Motor Efficiency: S - Standard
- Motor Speed: Q - 1550 RPM
- Controllers: 2 - LekTrol SS Speed Ctrlr (Loose)
- Service Switches: A - NEMA 1 - loose
- Internal Wiring: 1 - NEMA 1
- Spark Resistance Construction: C - AMCA C Spark Resistance
- Curb Cap: A - Alum Curb Cap (Std)
- Model Parent: DX13D
- Damper Type: BD - Backdraft Damper
- Application: E - Exhaust

(continued)

Performance

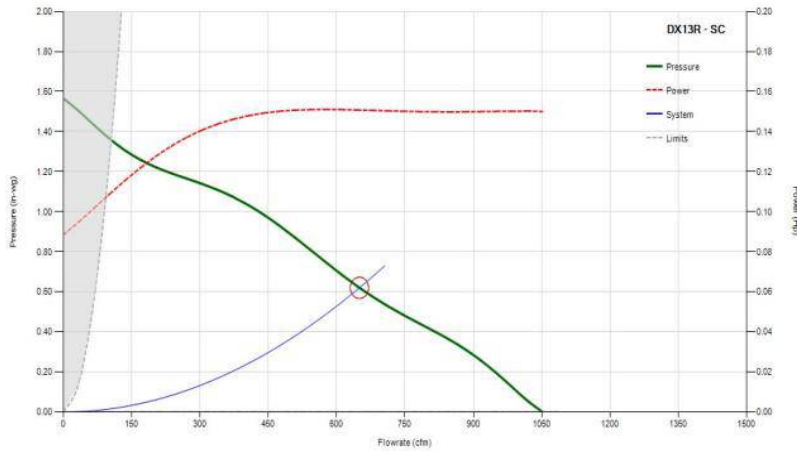

Operating Point

Volume (CFM)	650
Static Pressure (in. wg)	0.62
Fan RPM	1547
Horse Power (BHP)	0.15
Elevation (ft)	0
Temperature (°F)	70
Drive Loss (%)	N/A
FEI	1.52

Motor Information

Motor HP	0.167 - 1/6 HP
Volt/Ph/Hz	115V /1/ 60
Enclosure	4 - OPAO
NEC FLA*	4.4
Weight+ (lbs)	C/F

* NEC FLA - based on tables 430.248 or 430.250 of National Electrical Code 2014. Actual motor FLA may vary depending on motor manufacturer.
 + Motor weight may vary depending on supplier

SOUND POWER

OCTAVE POWER CENTER FREQUENCY (hz)

63	125	250	500	1000	2000	4000	8000
70	71	74	63	58	55	52	46

LWA	dBA	Sones
68	56.3	8.24

LwA - Weighted sound power, based on ANSI S1.4, dBA - Weighted sound pressure, based on 11.5 dB attenuation per Octave band at 5 ft. Sones - calculated using AMCA 301 at 5 ft.



Damper

Control or General with various blade type dampers

Quantity: 1
Special: None

Product Image

Damper

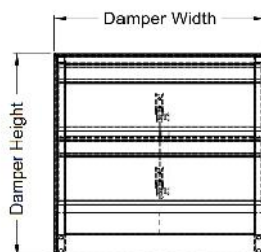
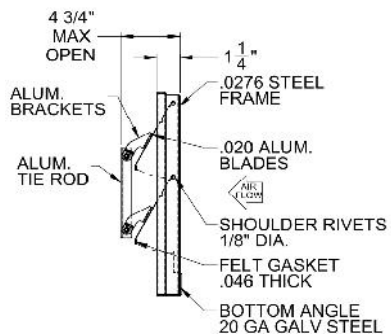

- Sensitive and responsive to low velocities up to 1500 FPM range.
- Square galvanized steel frame,
- Multi-leaf, roll formed aluminum blades; with
- Nylon bearings; and
- Felt Edges for quiet operation

Model Parent	Size	Part Number	Height	Width	No Blades	No Sections
DX13D	13	25003-0	11.25	11.25	2	1

Options or Accessories Listing

Model Parent DX13D	Blade Action 1 - Parallel
Application E - Exhaust	Flange 0 - None
Damper Type BD - Backdraft Damper	Coating 0 - None
Damper Material A - Aluminum	

Schedule

ID	Quantity	Tag
1	1	EF-1

RC-2A-A12

Prefabricated Heavy-gauge steel Roof Curbs

Product Image

RC-2A-A12

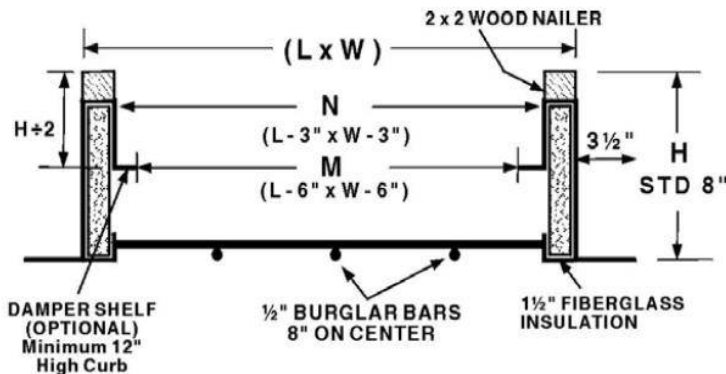

Prefabricated Roof Curbs shall be Unibeam supplied by PennBarry, Plano, Texas 75074.

Heavy-gauge steel with welded corner seams shall cover 1-1/2" thick 3 lb. density fiberglass insulation. A 1-1/2" wide wood nailer (Unibeam) with top surface is provided for fan installation and/or roofing paper. Flat (single or double pitch optional) curb fastening flange shall be Cantless. Optional vented sides available without fiberglass insulation.

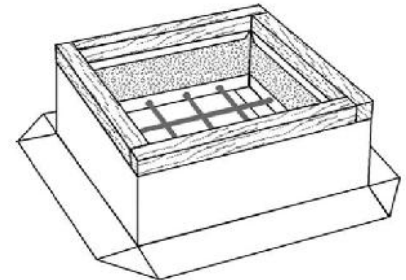

L	W	N	N	H	Roof Opening	
17	17	14	14	12	14	14

Options or Accessories Listing

Curb Parent EVD	Burglar Bar Pattern T - 2 Direction
Roof Slope 0 - None	Burglar Bar Size B - 1/2" Diameter
Curb Liner 0 - None	
Damper Hold Plate P - Plate	
Curb Gasket 0 - None	
Wood Nailer W - Wooden Nailer	

Product Notes

- 1 1/2" Rigid Fiberglass Insulation
- Wood Nailer
- Curb Fastening Flange
- Roof Structure - By Others
- Backdraft Damper - Optional

Schedule

ID	Quantity	Tag	Curb Dim1	Curb Dim2	Roof Pitch Dim by 12
1	1		17	17	0

DX10R - SC

Quantity: 1
Special: None

Dimensions

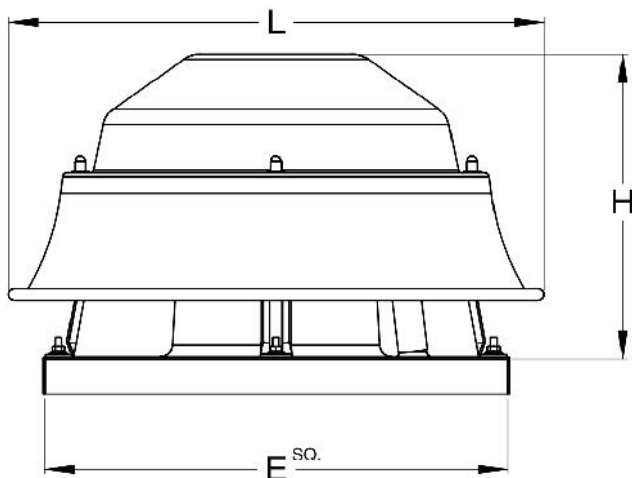

Unit Size	Motor Speed	E	H
10	Q - 1550 RPM	18.5	13.375

L	Weight
20.875	29

Standard Construction Features

- Weatherproof Housing
- Heavy Gauge Spun Aluminum Construction
- Aluminum Centrifugal Fan Wheels Statically & Dynamically balanced
- Spark-resistant, Non-overloading
- Aluminum spun venturis
- Continuous Duty Motors
- AMCA Licensed Ratings Seal for Air & Sound Performance (DX)
- UL and cUL Listed

Accessories

- Temperature: 70
- UL / ETL Listing: 1 - UL 705
- Unit Size: 10
- Drive Type: D - Direct
- Motor Efficiency: S - Standard
- Motor Speed: Q - 1550 RPM
- HP: 0.083 - 1/12 HP
- Controllers: 2 - LekTrol SS Speed Ctrlr (Loose)
- Service Switches: A - NEMA 1 - loose
- Internal Wiring: 1 - NEMA 1
- Spark Resistance Construction: C - AMCA C Spark Resistance
- Curb Cap: A - Alum Curb Cap (Std)
- Model Parent: DX10D
- Damper Type: BD - Backdraft Damper
- Application: E - Exhaust

(continued)

Performance

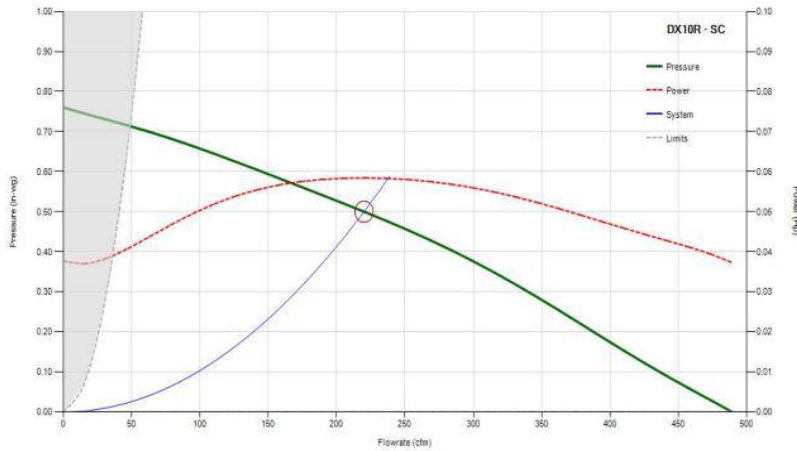

Operating Point

Volume (CFM)	220
Static Pressure (in. wg)	0.5
Fan RPM	1357
Horse Power (BHP)	0.06
Elevation (ft)	0
Temperature (°F)	70
Drive Loss (%)	N/A
FEI	1.34

Motor Information

Motor HP	0.083 - 1/12 HP
Volt/Ph/Hz	115V /1/ 60
Enclosure	4 - OPAO
NEC FLA*	0
Weight+ (lbs)	C/F

* NEC FLA - based on tables 430.248 or 430.250 of National Electrical Code 2014. Actual motor FLA may vary depending on motor manufacturer.
 + Motor weight may vary depending on supplier

SOUND POWER

OCTAVE POWER CENTER FREQUENCY (hz)

63	125	250	500	1000	2000	4000	8000
63	71	65	58	53	48	44	35

LWA	dBA	Sones
62	50	5.31

LwA - Weighted sound power, based on ANSI S1.4, dBA - Weighted sound pressure, based on 11.5 dB attenuation per Octave band at 5 ft. Sones - calculated using AMCA 301 at 5 ft.



Damper

Control or General with various blade type dampers

Quantity: 1
Special: None

Product Image

Damper

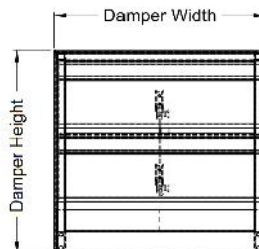
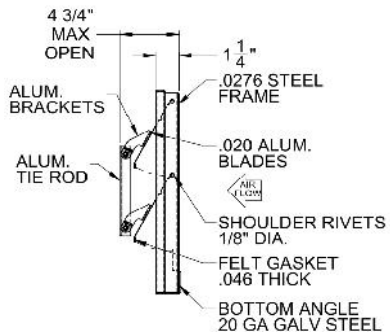

- Sensitive and responsive to low velocities up to 1500 FPM range.
- Square galvanized steel frame,
- Multi-leaf, roll formed aluminum blades; with
- Nylon bearings; and
- Felt Edges for quiet operation

Model Parent	Size	Part Number	Height	Width	No Blades	No Sections
DX10D	13	25003-0	11.25	11.25	2	1

Options or Accessories Listing

Model Parent DX10D	Blade Action 1 - Parallel
Application E - Exhaust	Flange 0 - None
Damper Type BD - Backdraft Damper	Coating 0 - None
Damper Material A - Aluminum	

Schedule

ID	Quantity	Tag
1	1	EF-2

RC-2A-A12

Prefabricated Heavy-gauge steel Roof Curbs

Product Image

RC-2A-A12

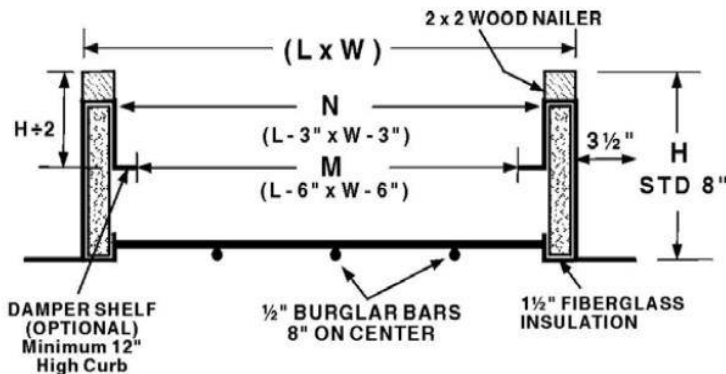

Prefabricated Roof Curbs shall be Unibeam supplied by PennBarry, Plano, Texas 75074.

Heavy-gauge steel with welded corner seams shall cover 1-1/2" thick 3 lb. density fiberglass insulation. A 1-1/2" wide wood nailer (Unibeam) with top surface is provided for fan installation and/or roofing paper. Flat (single or double pitch optional) curb fastening flange shall be Cantless. Optional vented sides available without fiberglass insulation.

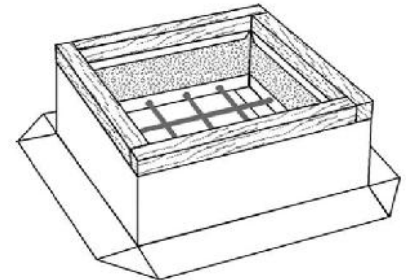

L	W	N	N	H	Roof Opening	
17	17	14	14	12	14	14

Options or Accessories Listing

Curb Parent EVD	Burglar Bar Pattern T - 2 Direction
Roof Slope 0 - None	Burglar Bar Size B - 1/2" Diameter
Curb Liner 0 - None	
Damper Hold Plate P - Plate	
Curb Gasket 0 - None	
Wood Nailer W - Wooden Nailer	

Product Notes

1. 1 1/2" Rigid Fiberglass Insulation
2. Wood Nailer
3. Curb Fastening Flange
4. Roof Structure - By Others
5. Backdraft Damper - Optional

Schedule

ID	Quantity	Tag	Curb Dim1	Curb Dim2	Roof Pitch Dim by 12
1	1		17	17	0

DX10R - SC

Quantity: 1
Special: None

Dimensions

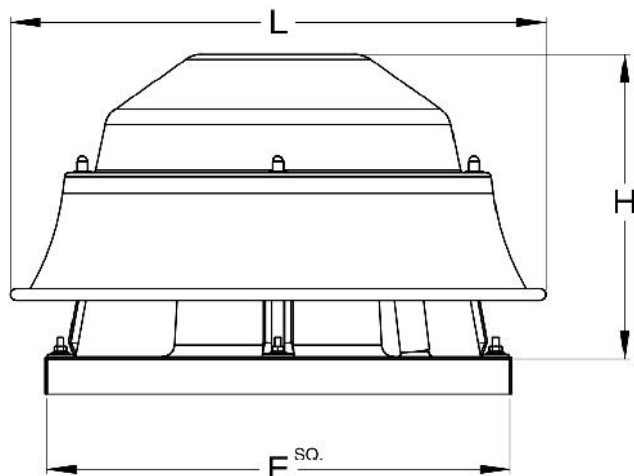

Unit Size	Motor Speed	E	H
10	Q - 1550 RPM	18.5	13.375

L	Weight
20.875	29

Standard Construction Features

- Weatherproof Housing
- Heavy Gauge Spun Aluminum Construction
- Aluminum Centrifugal Fan Wheels Statically & Dynamically balanced
- Spark-resistant, Non-overloading
- Aluminum spun venturis
- Continuous Duty Motors
- AMCA Licensed Ratings Seal for Air & Sound Performance (DX)
- UL and cUL Listed

Accessories

- Temperature: 70
- UL / ETL Listing: 1 - UL 705
- Unit Size: 10
- Drive Type: D - Direct
- Motor Efficiency: S - Standard
- Motor Speed: Q - 1550 RPM
- HP: 0.083 - 1/12 HP
- Controllers: 2 - LekTrol SS Speed Ctrlr (Loose)
- Service Switches: A - NEMA 1 - loose
- Internal Wiring: 1 - NEMA 1
- Spark Resistance Construction: C - AMCA C Spark Resistance
- Curb Cap: A - Alum Curb Cap (Std)
- Model Parent: DX10D
- Damper Type: BD - Backdraft Damper
- Application: E - Exhaust

(continued)

Performance

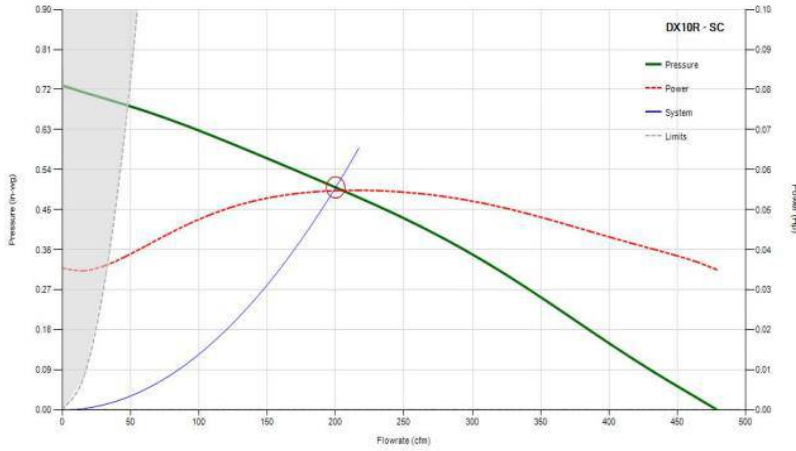

Operating Point

Volume (CFM)	200
Static Pressure (in. wg)	0.5
Fan RPM	1329
Horse Power (BHP)	0.05
Elevation (ft)	0
Temperature (°F)	70
Drive Loss (%)	N/A
FEI	1.39

Motor Information

Motor HP	0.083 - 1/12 HP
Volt/Ph/Hz	115V /1/ 60
Enclosure	4 - OPAO
NEC FLA*	0
Weight+ (lbs)	C/F

* NEC FLA - based on tables 430.248 or 430.250 of National Electrical Code 2014. Actual motor FLA may vary depending on motor manufacturer.
 + Motor weight may vary depending on supplier

SOUND POWER

OCTAVE POWER CENTER FREQUENCY (hz)

63	125	250	500	1000	2000	4000	8000
63	70	65	57	52	47	43	34

LWA	dBA	Sones
61	49.4	5.1

LwA - Weighted sound power, based on ANSI S1.4, dBA - Weighted sound pressure, based on 11.5 dB attenuation per Octave band at 5 ft. Sones - calculated using AMCA 301 at 5 ft.



Damper

Control or General with various blade type dampers

Quantity: 1
Special: None

Product Image

Damper

4 3/4" MAX OPEN
 ALUM. BRACKETS
 ALUM. TIE ROD
 1 1/4"
 0276 STEEL FRAME
 020 ALUM. BLADES
 SHOULDER RIVETS 1/8" DIA.
 FELT GASKET .046 THICK
 BOTTOM ANGLE 20 GA GALV STEEL
 Damper Width
 Damper Height

- Sensitive and responsive to low velocities up to 1500 FPM range.
- Square galvanized steel frame,
- Multi-leaf, roll formed aluminum blades; with
- Nylon bearings; and
- Felt Edges for quiet operation

Model Parent	Size	Part Number	Height	Width	No Blades	No Sections
DX10D	13	25003-0	11.25	11.25	2	1

Options or Accessories Listing

Model Parent DX10D	Blade Action 1 - Parallel
Application E - Exhaust	Flange 0 - None
Damper Type BD - Backdraft Damper	Coating 0 - None
Damper Material A - Aluminum	

Schedule

ID	Quantity	Tag
1	1	EF-3

RC-2A-A12

Prefabricated Heavy-gauge steel Roof Curbs

Product Image

RC-2A-A12

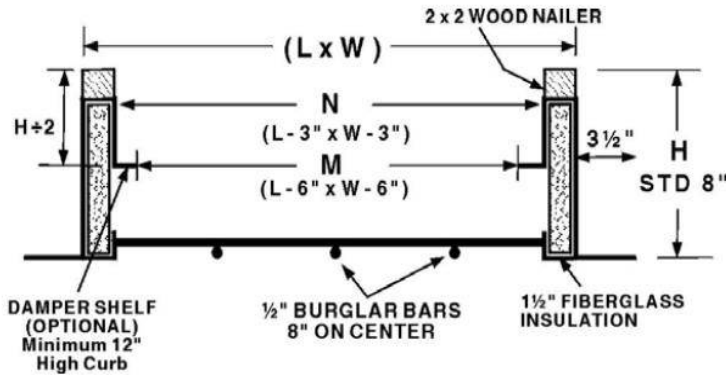

Prefabricated Roof Curbs shall be Unibeam supplied by PennBarry, Plano, Texas 75074.

Heavy-gauge steel with welded corner seams shall cover 1-1/2" thick 3 lb. density fiberglass insulation. A 1-1/2" wide wood nailer (Unibeam) with top surface is provided for fan installation and/or roofing paper. Flat (single or double pitch optional) curb fastening flange shall be Cantless. Optional vented sides available without fiberglass insulation.

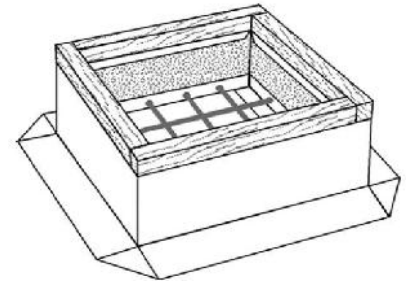

L	W	N	N	H	Roof Opening	
17	17	14	14	12	14	14

Options or Accessories Listing

Curb Parent EVD	Burglar Bar Pattern T - 2 Direction
Roof Slope 0 - None	Burglar Bar Size B - 1/2" Diameter
Curb Liner 0 - None	
Damper Hold Plate P - Plate	
Curb Gasket 0 - None	
Wood Nailer W - Wooden Nailer	

Product Notes

- 1 1/2" Rigid Fiberglass Insulation
- Wood Nailer
- Curb Fastening Flange
- Roof Structure - By Others
- Backdraft Damper - Optional

Schedule

ID	Quantity	Tag	Curb Dim1	Curb Dim2	Roof Pitch Dim by 12
1	1		17	17	0