



Submittal Data

PET SUPPLIES PLUS WILMINGTON

Date: March 24, 2022

SUBMITTAL REVIEW	
<input checked="" type="checkbox"/> REVIEWED	<input type="checkbox"/> REVISE AND RESUBMIT
<input type="checkbox"/> MAKE CORRECTIONS NOTED	<input type="checkbox"/> SUBMIT SPECIFIED ITEM
CHECKING IS ONLY FOR GENERAL CONFORMANCE WITH THE DESIGN CONCEPT OF THE PROJECT AND GENERAL COMPLIANCE WITH THE INFORMATION IN THE CONTRACT DOCUMENTS. ANY ACTION SHOWN ABOVE, IS SUBJECT TO THE REQUIREMENTS OF THE PLANS AND SPECIFICATIONS. CONTRACTOR IS RESPONSIBLE FOR: DIMENSIONS WHICH SHALL BE FABRICATED AND CORRELATED AT THE JOB SITE; FABRICATION PROCESSES AND TECHNIQUES OF CONSTRUCTION; COORDINATION OF HIS WORK WITH THAT OF ALL OTHER TRADES; AND THE SATISFACTORY PERFORMANCE OF HIS WORK.	
WHS ENGINEERING INC.	
2012 WEST 25TH STREET, SUITE 200, CLEVELAND, OH 44113	
BY: WHS	DATE: 07-06-23

Submitted unit's MOCP is 30A versus 35A as a basis of design. Coordinate with EC to provide 30A/3 circuit breaker and 3#10 & 1#10 ground in 3/4" conduit routed from panel to unit. Provide non-fused disconnect at or within sight of unit.



Plan-ID	Qty	Model No	Description	Page
RTU-01	1	RGV048HEFA0AAA	Package Gas 208/230-3 ph	3
(10-2020) Limited Warranty for All Commercial Rooftops & Commercial Split System Products				9
(12-2022) Limited Warranty Certificate for Residential & 3 Phase Small Package Products				11

AHRI Rated Cooling Performance

AHRI Certified Reference #	202535786	
AHRI Rated Clg Capacity	47,000	Btuh
EER	11.60	EER
SEER	14	SEER

Cooling Performance @ Project Parameters

Net Cooling Capacity	48,400	Btuh
Net Sensible Capacity	34,300	Btuh
Net Latent Capacity	14,100	Btuh
Efficiency (at AHRI)	11.60	EER
SEER	14	SEER
Outdoor DB Temp	95.0	°F
Entering DB Temp	80.0	°F
Entering WB Temp	67.0	°F
Leaving DB Temp	60.2	°F
Leaving WB Temp	57.6	°F

Heating Performance

Heating Capacity Output	88,000	Btuh
Heating Capacity Input	110,000	Btuh
Thermal Efficiency	80%	
Orientation	Downflow	

Supply Air Performance

Total Supply Air	1600	cfm
External Static Pressure	0.80	in wg.
Blower Type:	Vane Axial Fan with Direct Drive ECM Motor	
Blower RPM	1994	rpm
Power Input	0.84	bhp
Motor Max BHP	1.06	bhp

Air flow is based on wet coil and clean filters

Supply Air Performance is shown for Cooling Mode

Electrical Data

Power Supply	208/230	Volts
	3	Phase
	60	Hertz
Minimum Circuit Ampacity	26	Amps
MOCP	30	Amps

Weight

Unit Weight	552	lb
Accessory Weight	220	lb
Total Weight	772	lb

Factory Options Selected

- E - Medium Heat Aluminized Steel Heat Exchanger
- A - Alum/Copper Condenser and Evaporator Coil

Field Installed Accessories

- CRRFCURB001A01 - 14 inch High Roof Curb. Ductwork attaches to the roof curb. Includes thru-the-bottom capability.
- CRECOMZR076A00 - Low LEAK - Vertical EconoMi\$er X with solid-state W7220 controller, gear-driven, modulating damper, spring return actuator, up to 100% barometric relief, supply and outdoor air temperature sensors, and CO2 sensor compatible, for use in electro mechanical controls only. Controller meets California Title 24 Section 120.2 Fault Detection and Diagnostic (FDD) requirements.
- CRCONVOUT01A00 - 20 Amp non (unit) powered convenience outlet kit is to provide a flexible installation method that will allow code compliance for height requirements of the GFCI outlet from finished roof surface on the range of rooftop and split system products as well as the capability to relocate the outlet into a more convenient location if necessary.
- DNCBDIOX005A00 - (CRCBDIOX005A00) CO2 Sensor for use in return airstream. Also includes Aspirator Box required for Duct Mounting.

NOTES

48TFD006A511

Features

PACKAGE GAS HEATING/ELECTRIC COOLING, R-410A SINGLE PACKAGE ROOFTOP

- R-410A Refrigerant
- ASHRAE 90.1 energy compliant efficiency levels
- Single-stage cooling capacity control.
- Rated in accordance with AHRI Standard 210/240
- Designed in accordance with Underwriters' Laboratories Standard 1995
- Exclusive noncorrosive composite condensate pan in accordance with ASHRAE 62 Standard, sloping design; side or center drain
- Induced draft combustion
- Redundant gas valve
- Pre-painted exterior panels and tested to 500 hr salt spray protection.
- Fixed refrigerant metering system.
- Fully insulated cabinet.
- Exclusive IGC solid-state control for on-board diagnostics with LED error code designation, burner control logic
- Access panels with easy grip handles and no-strip screw feature.
- Two-inch disposable return air filters
- Tool-less filter access door
- Direct Drive ECM Vane Axial indoor fan system
- New unit control board with intuitive quick fan speed adjustment with simple safety circuit troubleshooting and control box arrangement
- Full perimeter base rail with built-in rigging adapters and fork truck slots.
- Scroll compressors with internal line-break overload protection
- 24-volt control circuit protected with resettable circuit breaker
- Two speed permanently lubricated evaporator-fan motor
- Two speed permanently lubricated, totally enclosed condenser motors
- Low pressure, freeze protection, and high pressure switches
- Exclusive IGC anti-cycle protection for gas heat operation
- Solid-state electronic direct spark ignition system.
- Flame roll-out safety protector.
- Liquid line filter drier

Warranty

- 10 year heat exchanger limited warranty
- 5 year compressor parts warranty
- 1 year limited parts warranty

A-Weighted Sound Power Level

SOUND RATING (dBA)	TYPICAL OCTAVE BAND SPECTRUM (dB, without tone adjustment)						
	125	250	500	1000	2000	4000	8000
79	84.7	80.5	76	72.4	68	62.8	59.3

NOTE: Tested in accordance with AHRI standard 270-2008 (not listed in AHRI)

RGV036-072 Base Unit Dimensions

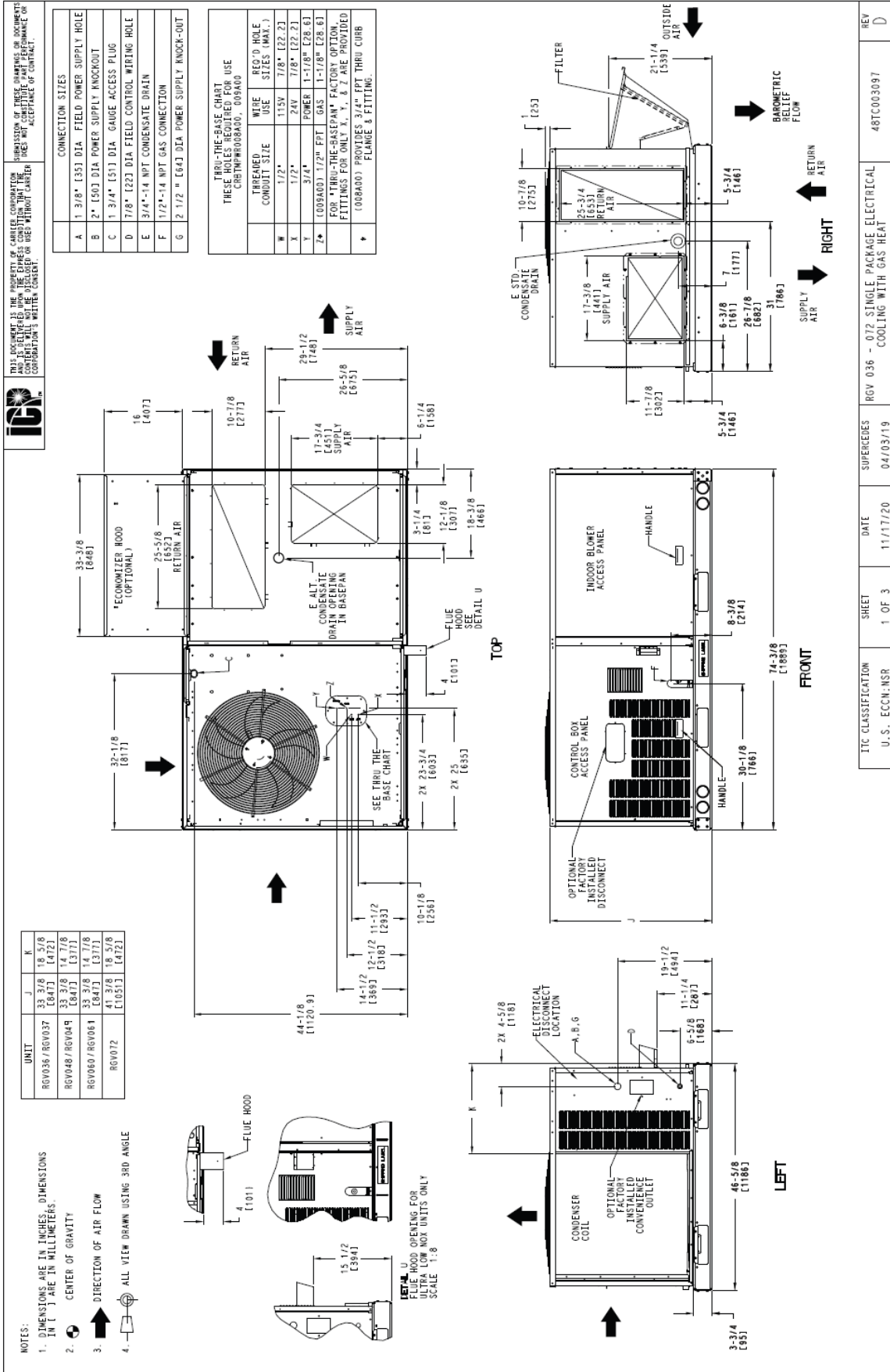

REV	DESCRIPTION	DATE	SUPERCEDES	BY
D	48TC003097	04/03/19	RGV 036 - 072 SINGLE PACKAGE ELECTRICAL COOLING WITH GAS HEAT	

RGV036-072 Base Unit Dimensions (cont)



UNIT	STD. UNIT WEIGHT (A)		CORNER WEIGHT (B)		CORNER WEIGHT (C)		CORNER WEIGHT (D)		C. G.			HEIGHT		
	LBS.	KG.	LBS.	KG.	LBS.	KG.	LBS.	KG.	X	Y	Z			
RGV036	482	219	113	51	116	53	128	58	125	57	37 3/8 [956]	24 3/16 [624]	18 1/4 [464]	Z
RGV048	543	246	138	63	133	60	138	63	36 1/2 [927]	23 3/8 [594]	18	18	18	[457]
RGV060	556	252	142	64	136	62	142	64	36 1/2 [927]	23 3/8 [594]	18	18	18	[457]
RGV072	607	275	162	73	152	69	141	64	36	36	[914]	22 1/2 [572]	19 3/8 [492]	

* STANDARD UNIT WEIGHT IS WITH LOW GAS HEAT AND WITHOUT PACKAGING. FOR OTHER OPTIONS AND ACCESSORIES, REFER TO THE PRODUCT DATA CATALOG.

THIS TABLE IS FOR *ULTRA LOW NOX* UNITS ONLY

UNIT	STD. UNIT WEIGHT **		CORNER WEIGHT (A)		CORNER WEIGHT (B)		CORNER WEIGHT (C)		CORNER WEIGHT (D)		C. G.			HEIGHT
	LBS.	KG.	LBS.	KG.	LBS.	KG.	LBS.	KG.	LBS.	KG.	X	Y	Z	
RGV036	512	233	120	55	122	55	136	62	134	61	37 1/2 [953]	24 11/16 [627]	18 1/8 [460]	Z
RGV048	513	260	146	66	139	63	141	64	147	67	36 3/8 [924]	23 1/2 [591]	18	[457]
RGV060	586	266	149	68	143	65	144	65	151	69	36 3/8 [924]	23 1/2 [591]	18	[457]

** STANDARD UNIT WEIGHT IS WITHOUT PACKAGING. FOR OTHER OPTIONS AND ACCESSORIES, REFER TO THE PRODUCT DATA CATALOG.

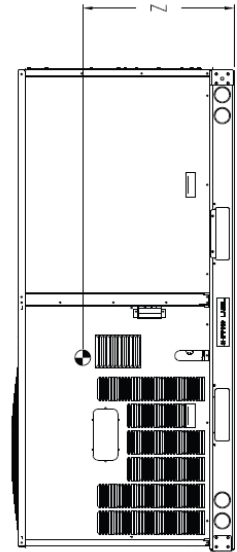
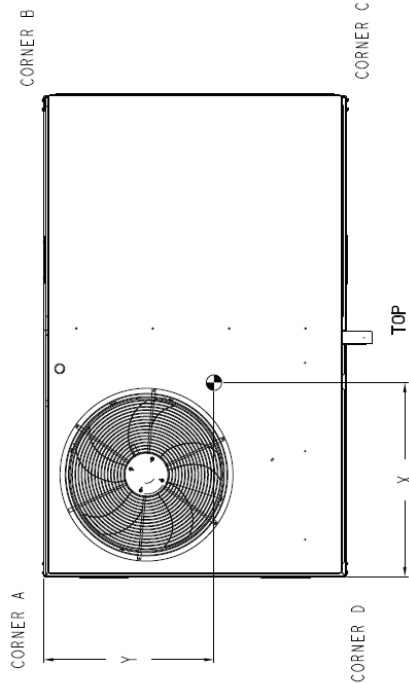
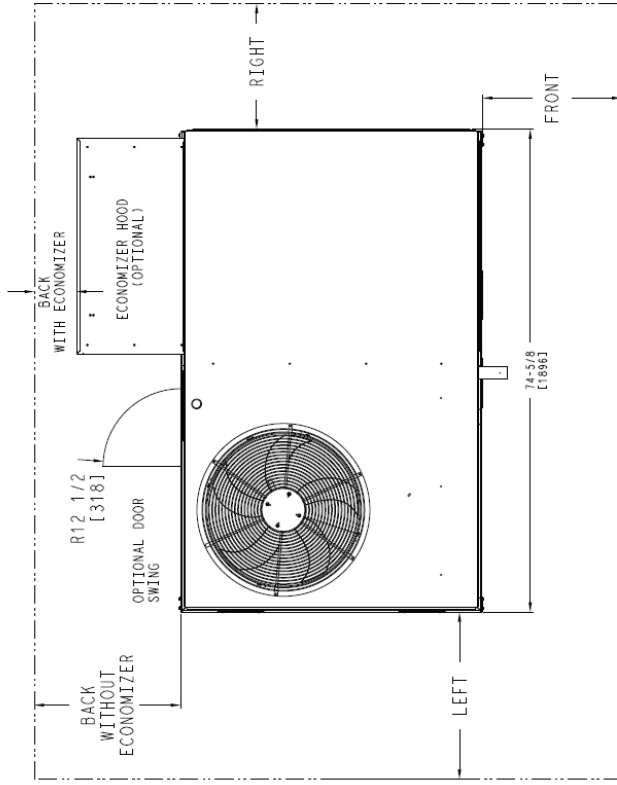

NOTES:
1. FOR ALL MINIMUM CLEARANCES LOCAL CODES OR JURISDICTIONS MAY PREVAIL.

SURFACE	CLEARANCE		OPERATING	
	SERVICE WITH CONDUCTIVE BARRIER	NONCONDUCTIVE BARRIER	SERVICE WITH CONDUCTIVE BARRIER	OPERATING
FRONT	48 [1219mm]	36 [914mm]	36 [914mm]	18 [457mm]
LEFT	48 [1219mm]	42 [1067mm]	42 [1067mm]	18 [457mm]
BACK W/O HOOD	48 [1219mm]	42 [1067mm]	42 [1067mm]	18 [457mm]
BACK W/HOOD	36 [914mm]	36 [914mm]	36 [914mm]	18 [457mm]
RIGHT	36 [914mm]	36 [914mm]	36 [914mm]	18 [457mm]
TOP	72 [1829mm]	72 [1829mm]	72 [1829mm]	72 [1829mm]

ITC CLASSIFICATION	SHEET	DATE	REV
U. S. ECCN: NSR	2 OF 3	11/17/20	D
RGV 036 - 072 SINGLE PACKAGE ELECTRICAL COOLING WITH GAS HEAT			48TC003097

RGV036-072 Base Unit Dimensions (cont)

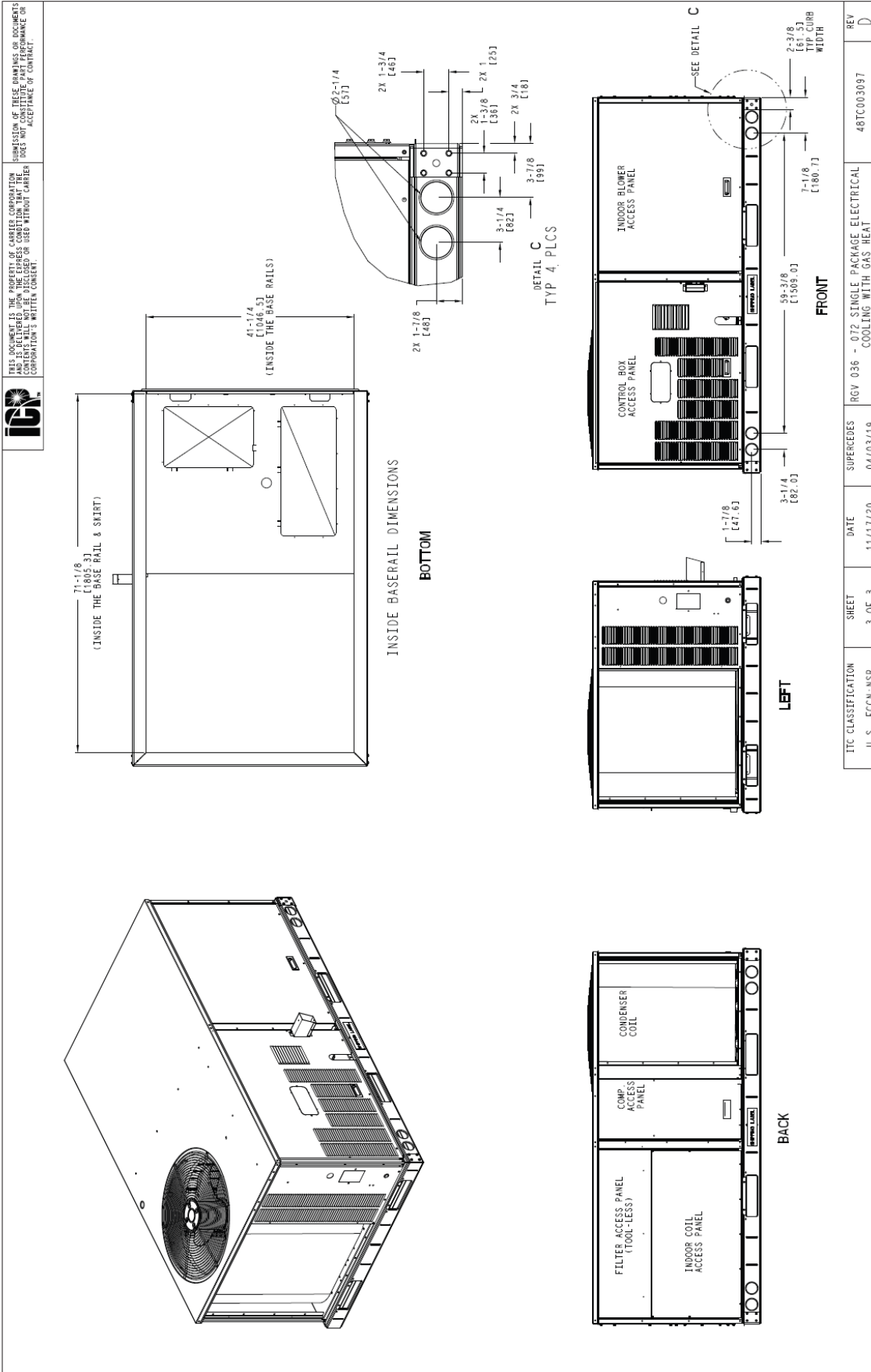

ITC CLASSIFICATION U.S. ECCN: NSR	SHEET 3 OF 3	DATE 11/17/20	SUPERCEDES 04/03/19	RGV 036 - 072 SINGLE PACKAGE ELECTRICAL COOLING WITH GAS HEAT	REV 48TC003097
--------------------------------------	-----------------	------------------	------------------------	---	-------------------

International Comfort Products

Limited Warranty Certificate

COVERED PRODUCTS: All Commercial Rooftops and Commercial Split System Products (See Chart Below)

FOR WARRANTY SERVICE OR REPAIR:

Contact the installer or an International Comfort Products dealer. You may be able to find the installer's name on the equipment or in your Owner's Packet. You can also find an International Comfort Products dealer online at www.icpusa.com.

For help, contact: International Comfort Products, Consumer Relations, P.O. Box 4808, Syracuse, New York, 13221, Phone 1-877-591-8908.

Product registration: You can register your product at <https://productregistration.icpusa.com>.

Fill in the installation date, model and serial number of the unit in the space provided below and retain for your records.

Model No. _____ Serial No. _____
 Date of Installation _____ Installed by _____
 Name of Owner _____ Address of Installation _____

International Comfort Products ("ICP") warrants this product against failure due to defect in materials or workmanship under normal use and maintenance as follows. All warranty periods begin on the date of original installation and are for the duration, in years, listed below. If a part fails due to defect during the applicable warranty period ICP will provide a new or remanufactured part, at ICP's option, to replace the failed defective part at no charge for the part. Alternatively, and at its option, ICP will allow a credit in the amount of the then factory selling price for a new equivalent part toward the retail purchase price of a new ICP product. Except as otherwise stated herein, those are ICP's exclusive obligations under this warranty for a product failure. All warranties in this document are subject to all provisions, conditions, limitations and exclusions listed below and on the reverse of this document.

This warranty is to the original purchasing owner. The limited parts warranty period in years, depending on the part is as shown in the chart below.

Warranty Details

Product Family	Product Description	Years of Warranty			
		Stainless Steel Heat Exchanger	Aluminized Heat Exchanger	Compressor	Parts
RGH, RGS, RGX, RGV, RGW ¹	Packaged Gas Electric	15	10 ²	5	1
RAH, RAS, RAX, RAV, RAW ¹	Package Air Conditioner	—	—	5	1
RHH, RHS, RHV, RHW, RHX ¹	Package Heat Pump	—	—	5	1
CAS, CHS	A/C and Heat Pump Condensers	—	—	5	1
FAS, FHS	A/C and Heat Pump Fan Coils	—	—	—	1

¹ AIR ECONOMIZER – If the product identified herein is equipped with a factory-installed air economizer that complies with California Energy Commission Title 24, Section 120.2 and Section 140.4, this limited warranty applies for four years from the date of the end of the first year all parts limited warranty to the factory-installed air economizer only in the product identified herein.

² Includes Low NOx Heat Exchanger and Ultra Low NOx Heat Exchanger and Burner assembly

LEGAL REMEDIES - The owner **must** notify the Company in writing, by certified or registered letter to ICP, Warranty Claims, P.O. Box 4808, Syracuse, New York 13221, of any defect or complaint with the product, stating the defect or complaint and a specific request for repair, replacement, or other correction of the product under warranty, mailed at least thirty (30) days before pursuing any legal rights or remedies.

International Comfort Products

Limited Warranty Certificate

CONDITIONS:

The Limited Warranty only applies if the following conditions are met:

1. Proof of purchase may be required at time of service.
2. The unit must be installed, and warranty work must be performed, by a licensed dealer or contractor.
3. The unit must be installed in accordance with ICP's installation instructions and in compliance with local codes. Improper installation may endanger the occupants of the dwelling or damage the product.
4. The unit must be operated in accordance with ICP's owner's manual provided with each unit. The product must not be misused.
5. The unit's rating plate must not be removed or defaced.
6. Proof must be supplied that the equipment has been properly maintained over the life of the warranty, i.e., a minimum of once-a-year maintenance.
7. The unit must be installed and located in the continental U.S.A., Alaska, Hawaii, or Canada.
8. Warranties apply only to products installed in their original installation location.
9. Defective parts must be returned to the distributor through a servicing dealer for credit.
10. All other accessories, including electric heaters used in commercial applications, will have a one (1) year limited warranty from date of installation.

LIMITATIONS OF WARRANTIES – All implied warranties (and implied conditions in Canada) including implied warranties or conditions of merchantability and fitness for a particular use or purpose are limited in duration to the period for which the limited warranty is given and applies. Some states or provinces do not allow limitations on how long an implied warranty or condition lasts, so this limitation may not apply to you. The express warranties made in this warranty are exclusive and may not be altered, enlarged, or changed by any distributor, dealer, or other person, whatsoever.

THIS WARRANTY DOES NOT COVER:

1. Labor or other costs incurred for diagnosing, repairing, removing, installing, shipping, servicing, or handling of either failed parts, or replacement parts, or new units.
2. Any product not installed pursuant to the regional efficiency standards issued by the Department of Energy.
3. Normal maintenance as outlined in the installation and servicing instructions or owner's manual including coil cleaning, filter cleaning and/or replacement, and lubrication.
4. Damage or repairs required as a consequence of improper shipping or handling, faulty installation, misapplication, abuse, improper servicing, unauthorized alteration, and/or improper operation.
5. Failure to start or damages due to voltage conditions, blown fuses, open circuit breakers, or the inadequacy, unavailability, or interruption of electrical, internet service provider, or mobile device carrier service or your home network.
6. Failure or damage as a result of floods, winds, fires, lightning, accidents, corrosive environments (except for coastal rated units in coastal environments), rust and wear, or other conditions beyond the control of ICP.
7. Parts not supplied or designated by ICP, or damages resulting from their use.
8. Electricity or fuel costs or increases in electricity or fuel costs from any reason whatsoever including additional or unusual use of supplemental electric heat.
9. Any special, indirect, or consequential property or commercial damage of any nature whatsoever. Some states do not allow the exclusion of incidental or consequential damages, so the above limitation may not apply to you.
10. Refrigerant or any costs related thereto.
11. Any product purchased on the internet.

This warranty gives you specific legal rights, and you may also have other rights which vary from state to state or province to province.

In the USA:
International Comfort Product
650 Heil-Quaker Avenue
P.O. Box 128
Lewisburg, Tennessee 37091
(931) 270-4100

In Canada:
International Comfort Products
Division of UTC Canada Corporation
6060 Burnside Court, Unit 1
Mississauga, Ontario L5T 2T5
(905) 795-8113

© Carrier 2020

Manufacturers of Airquest®, Arcoaire®, Climette®, Comfortmaker®, Day & Night™, Dettson®, Heil®, ICP Commercial®, Keeprite®, Tempstar®, and other quality brand name private label products.

525 06 1501 00 October 2020

International Comfort Products

Limited Warranty Certificate

Covered Products: Small Package Gas-Electric, Small Package Air Conditioner, Small Package Heat Pump, Small Package Dual Fuel Products less than 65,000-Btuh Cooling Capacity (See Chart Below).

FOR WARRANTY SERVICE OR REPAIR:

Contact the installer or an International Comfort Products dealer. You may be able to find the installer's name on the equipment or in your Owner's Packet. You can also find an International Comfort Products dealer online at www.icpusa.com.

For additional help, contact: International Comfort Products, Consumer Relations, 1-877-591-8908.

Product registration: Register your product at: <https://productregistration.icpusa.com>.

Fill in the installation date, model and serial number of the unit in the space provided below and retain for your records.

Model No. _____	Serial No. _____
Date of Installation _____	Installed by _____
Name of Owner _____	Address of Installation _____

International Comfort Products ("ICP") warrants this product against failure due to defect in materials or workmanship under normal use and maintenance as follows. All warranty periods begin on the date of original installation and are for the duration, in years, listed below. If a part fails due to defect during the applicable warranty period ICP will provide a new or remanufactured part, at ICP's option, to replace the failed defective part at no charge for the part. Alternatively, and at its option, ICP will allow a credit in the amount of the then factory selling price for a new equivalent part toward the retail purchase price of a new ICP product. Except as otherwise stated herein, those are ICP's exclusive obligations under this warranty for a product failure. All warranties in this document are subject to all provisions, conditions, limitations and exclusions listed below and on the reverse of this document.

RESIDENTIAL APPLICATIONS

This warranty is to the original purchasing owner and subsequent owners only to the extent and as stated in the Warranty Conditions and below. The limited parts warranty period in years, depending on the part and the claimant, is as shown in the chart below.

No Hassle Replacement™ limited warranty – Available on qualifying models only, see chart below for list of covered models and duration of warranty. Available to original purchaser in owner-occupied single family residential applications only, and is not available to subsequent homeowners. If the heat exchanger, compressor or condenser coil fails due to defect during the applicable No Hassle Replacement limited warranty time period, a one-time replacement with a comparable ICP unit will be provided. This unit replacement warranty is in addition to the standard parts warranty. Proof of purchase and installation date will be required. No Hassle Replacement limited warranty replacements are subject to review and verification by an ICP representative. The remaining balance of the original unit's standard warranty will be transferred to the replacement unit. This limited warranty is subject to all provisions, conditions, limitations and exclusions listed below and on the reverse of this document.

Single-Phase Models Product Family	Warranty Period in Years				
	No Hassle*	Heat Exchanger		Parts (Including Compressor and Coil)	
	Original Owner	Original Owner	Subsequent Owners	Original Owner	Subsequent Owners
PGR5	5	20 or Lifetime†	20	5 or 10‡	5
PAR5, PHR5	5	-	-	5 or 10‡	5
PAD4, PHD4	3	-	-	5 or 10‡	5
PDD4, PGD4	3	20 or Lifetime†	20	5 or 10‡	5
PAJ4, PHJ4	-	-	-	5 or 10‡	5
Three-Phase Models Product Family	No Hassle*	Heat Exchanger	Compressor	Parts	
	Original Owner	Original Owner	Original Owner	Original Owner	Subsequent Owners
PAD, PGD, PHD, PAR, PHR, PGR	-	10	5	1	-

*. See Warranty Conditions on reverse.

†. If properly registered within ninety (90) days after original installation, the heat exchanger has a limited lifetime warranty to the original purchaser. Otherwise, the heat exchanger warranty is twenty (20) years (except in California and Quebec, and other jurisdictions that prohibit warranty benefits conditioned on registration.)

‡. If properly registered within ninety (90) days after original installation, parts are warranted to the original purchaser for a period of ten (10) years. Otherwise, parts warranty is five (5) years (except in California and Quebec, and other jurisdictions that prohibit warranty benefits conditioned on registration).

OTHER APPLICATIONS

The warranty period is ten (10) years on the heat exchanger, five (5) years on compressor and one (1) year on all other parts. The warranty is to the original owner only and is not available for subsequent owners.

LEGAL REMEDIES - The owner must notify the Company in writing, by certified or registered letter to ICP, Warranty Claims, P.O. Box 4808, Syracuse, New York 13221, of any defect or complaint with the product, stating the defect or complaint and a specific request for repair, replacement, or other correction of the product under warranty, mailed at least thirty (30) days before pursuing any legal rights or remedies.

International Comfort Products

Limited Warranty Certificate

CONDITIONS:

The Limited Warranty only applies if the following conditions are met:

1. To obtain the longer warranty period as shown in the table under original owner, the product must be properly registered at <https://productregistration.icpusa.com> within ninety (90) days of original installation. In jurisdictions where warranty benefits conditioned on registration are prohibited by law, registration is not required and the longer warranty period shown will apply.
2. If the original installation date cannot be verified, then the warranty period begins ninety (90) days from the date of product manufacture (as indicated by the model and serial number). Where a product is installed in a newly constructed home, the date of installation is the date the original homeowner purchased the home from the builder.
3. The limited parts warranty period as shown in the table under subsequent owner does not require registration.
4. Proof of purchase may be required at time of service.
5. The unit must be installed, and warranty work must be performed, by a licensed dealer or contractor.
6. The unit must be installed in accordance with ICP's installation instructions and in compliance with local codes. Improper installation may endanger the occupants of the dwelling or damage the product.
7. The unit must be operated in accordance with ICP's owner's manual provided with each unit. The product must not be misused.
8. The unit's rating plate must not be removed or defaced.
9. Proof must be supplied that the equipment has been properly maintained over the life of the warranty, i.e., a minimum of once-a-year maintenance.
10. The unit must be installed and located in the continental U.S.A., Alaska, Hawaii, or Canada.
11. Warranties apply only to products installed in their original installation location.
12. Defective parts must be returned to the distributor through a servicing dealer for credit.
13. Electric Heater accessories used in residential applications will have a five (5) year limited warranty from the date of original installation.
14. The No Hassle Replacement limited warranty applies only if Claimant is the original purchaser of the product.

LIMITATIONS OF WARRANTIES – All implied warranties (and implied conditions in Canada) including implied warranties or conditions of merchantability and fitness for a particular use or purpose are limited in duration to the period for which the limited warranty is given and applies. Some states or provinces do not allow limitations on how long an implied warranty or condition lasts, so this limitation may not apply to you. The express warranties made in this warranty are exclusive and may not be altered, enlarged, or changed by any distributor, dealer, or other person, whatsoever.

THIS WARRANTY DOES NOT COVER:

1. Labor or other costs incurred for diagnosing, repairing, removing, installing, shipping, servicing, or handling of either failed parts, or replacement parts, or new units.
2. Any product not installed pursuant to the regional efficiency standards issued by the Department of Energy.
3. Normal maintenance as outlined in the installation and servicing instructions or owner's manual including coil cleaning, filter cleaning and/or replacement, and lubrication.
4. Damage or repairs required as a consequence of improper shipping or handling, faulty installation, misapplication, abuse, improper servicing, unauthorized alteration, and/or improper operation.
5. Failure to start due to voltage conditions, blown fuses, open circuit breakers or the inadequacy, unavailability, or interruption of electrical, Internet service provider, or mobile device carrier service or your home network.
6. Failure or damage as a result of floods, winds, fires, lightning, accidents, corrosive environments (except for coastal rated units in coastal environments), rust and wear, or other conditions beyond the control of ICP.
7. Parts not supplied or designated by ICP, or damages resulting from their use.
8. Electricity or fuel costs or increases in electricity or fuel costs from any reason whatsoever including additional or unusual use of supplemental electric heat.
9. **Any special, indirect, or consequential property or commercial damage of any nature whatsoever.** Some states do not allow the exclusion of incidental or consequential damages, so the above limitation may not apply to you.
10. Refrigerant or any costs related thereto.
11. Any product purchased on the internet.

This warranty gives you specific legal rights, and you may also have other rights which vary from state to state or province to province.

In the USA:
International Comfort Products
650 Heil-Quaker Avenue
P.O. Box 128
Lewisburg, Tennessee 37091
(931) 270-4100

In Canada:
International Comfort Products
Division of Carrier Canada Corporation
6060 Burnside Court, Unit 1
Mississauga, Ontario L5T 2T5
(905) 795-8113