

FOR QUESTIONS, CALL THE
Highwoods Group
REGION 40
PHONE: (919) 875-0420
EMAIL: reg40@captiveaire.com

PATENT NUMBERS

AC-PSP (UNITED STATES) - US PATENT 7963830 B2.
AC-PSP WALL (CANADA) - CA PATENT 2820509.
AC-PSP ISLAND (CANADA) - CA PATENT 2520330.

SPECIFICATION: CAPTRATE® GREASE-STOP® SOLID FILTER

THE CAPTRATE GREASE-STOP SOLID FILTER IS A SINGLE-STAGE FILTER FEATURING A UNIQUE S-BAFFLE DESIGN IN CONJUNCTION WITH A SLOTTED REAR BAFFLE DESIGN, TO DELIVER EXCEPTIONAL FILTRATION EFFICIENCY.

FILTER IS STAINLESS STEEL CONSTRUCTION, AND SIZED TO FIT INTO STANDARD 2-INCH DEEP HOOD CHANNEL(S).

UNITS SHALL INCLUDE STAINLESS STEEL HANDLES AND A FASTENING DEVICE TO SECURE THE TWO COMPONENTS WHEN ASSEMBLED.

GREASE EXTRACTION EFFICIENCY PERFORMANCE SHALL REMOVE AT LEAST 75% OF GREASE PARTICLES FIVE MICRONS IN SIZE, AND 85% GREASE PARTICLES SEVEN MICRONS IN SIZE AND LARGER, WITH A CORRESPONDING PRESSURE DROP NOT TO EXCEED 1.0 INCHES OF WATER GAUGE.

THE CAPTRATE GREASE-STOP SOLID WAS TESTED TO ASTM STANDARD ASTM F2519-05, MANUFACTURER APPROVED FOR USE IN SOLID FUEL APPLICATIONS AS A SPARK ARRESTER.

EFFICIENCY VS. PARTICLE DIAMETER

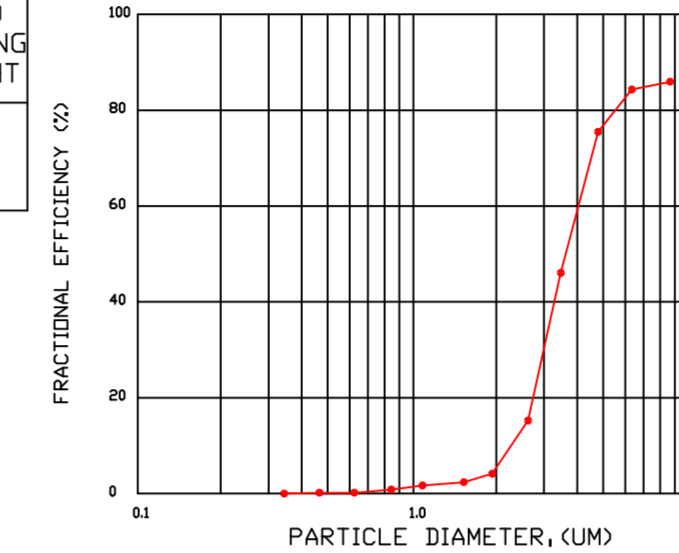

PRESSURE DROP VS. FLOW RATE

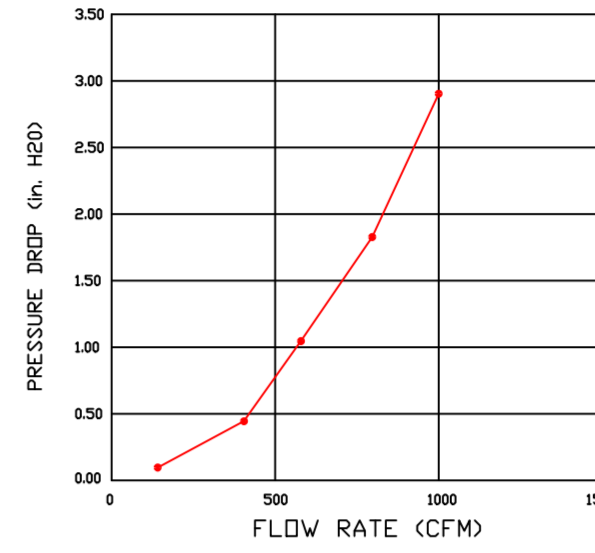

CAPTRATE FILTERS ARE BUILT IN COMPLIANCE WITH:
NFPA #96.
NSF STANDARD #2.
UL STANDARD #1046.
INT. MECH. CODE (IMC).
ULC-S649.



HOOD INFORMATION - JOB#5945450

| HOOD NO | TAG | MODEL | MANUFACTURER | LENGTH | MAX COOKING TEMP | TYPE | APPLIANCE DUTY | DESIGN CFM/FT | TOTAL EXH CFM | EXHAUST PLENUM RISER(S) | | | | | | MUA CFM | AC CFM | HOOD CONSTRUCTION | HOOD CONFIG | | |
|---------|-----|-------------------|--------------|--------|------------------|------|----------------|---------------|---------------|-------------------------|------|--------|-----|------|------|---------|--------|-------------------|----------------------|------------|-------|
| | | | | | | | | | | WIDTH | LENG | HEIGHT | DIA | CFM | VEL | | | | SP | END TO END | ROW |
| 1 | | 5424 ND-2-ACPSP-F | CAPTIVEAIRE | 12' 9" | 600 DEG | I | HEAVY | 200 | 2550 | 10' | 24' | 4' | | 2550 | 1530 | -0.966' | 1300 | 696 | 430 SS WHERE EXPOSED | ALONE | ALONE |

HOOD INFORMATION

| HOOD NO | TAG | FILTER(S) | | | | | LIGHT(S) | | | | UTILITY CABINET(S) | | | | FIRE SYSTEM PIPING | HOOD HANGING WEIGHT | |
|---------|-----|-----------------------|-----|--------|--------|------------------------|----------|----------------|------------|----------|--------------------|------------------|---------|--------------------|--------------------|---------------------|-------------------|
| | | TYPE | QTY | HEIGHT | LENGTH | EFFICIENCY @ 7 MICRONS | QTY | TYPE | WIRE GUARD | LOCATION | SIZE | FIRE SYSTEM TYPE | SIZE | ELECTRICAL MODEL # | | | SWITCHES QUANTITY |
| 1 | | CAPTRATE SOLID FILTER | 9 | 16" | 16" | 85% SEE FILTER SPEC | 8 | L55 SERIES E26 | NO | LEFT | 12"x54"x24" | ANSUL R-102 | 3.0/3.0 | SC-311110MA | 1 LIGHT 1 FAN | YES | 1029 LBS |

HOOD OPTIONS

| HOOD NO | TAG | OPTION |
|---------|-----|---|
| 1 | | FIELD WRAPPER 10.00" HIGH FRONT, LEFT, RIGHT. INSULATION FOR BACK OF HOOD. RISER SENSOR INSTALL 6IN PLEN. RIGHT VERTICAL END PANEL 27" TOP WIDTH, 21" BOTTOM WIDTH, 80" HIGH INSULATED 430 SS. LEFT VERTICAL END PANEL 27" TOP WIDTH, 21" BOTTOM WIDTH, 80" HIGH INSULATED 430 SS. FULL DIMENSION HANGING BRACKET - FRONT. |

PERFORATED SUPPLY PLENUM(S)

| HOOD NO | TAG | POS | LENGTH | WIDTH | HEIGHT | TYPE | RISER(S) | | | | | | | | | | | | | | | | | | | | | | | | | | | | | | | | | | | | | | | | | |
|---------|-----|-------|--------|-------|--------|------|----------|------|-----|-----|--------|-----|----|-----|--|-----|--------|-----|----|-----|--|-----|--------|----|--|----|-----|--------|----|--|----|-----|--------|----|--|----|-----|--------|----|--|----|-----|--------|----|--|----|-----|--------|
| | | | | | | | WIDTH | LENG | DIA | CFM | SP | | | | | | | | | | | | | | | | | | | | | | | | | | | | | | | | | | | | | |
| 1 | | Front | 165' | 19' | 6' | MUA | 6" | 28" | | 432 | 0.127" | MUA | 6" | 28" | | 432 | 0.127" | MUA | 6" | 28" | | 432 | 0.127" | AC | | 8" | 116 | 0.043" | AC | | 8" | 116 | 0.043" | AC | | 8" | 116 | 0.043" | AC | | 8" | 116 | 0.043" | AC | | 8" | 116 | 0.043" |

1" LAYER OF INSULATION FACTORY INSTALLED IN INTERNAL BACK STANDOFF. MEETS 0 INCH REQUIREMENTS FOR CLEARANCE TO COMBUSTIBLE SURFACES.

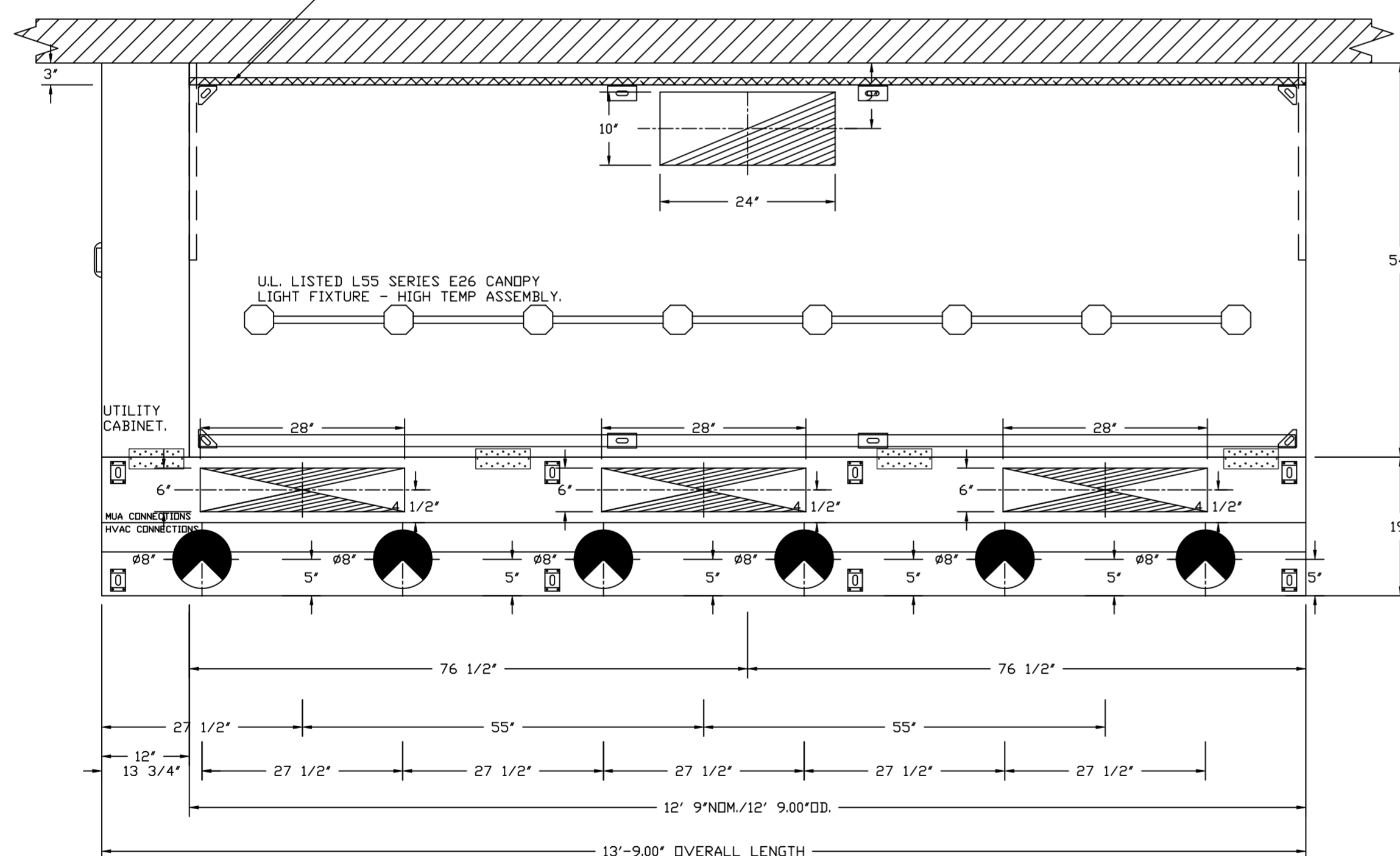

PLAN VIEW - HOOD #1
12' 9.00" LONG 5424ND-2-ACPSP-F
NOTE: ADDITIONAL HANGING ANGLES PROVIDED FOR HOODS 12' AND LONGER.

ACPSP SHIPS LOOSE FOR FIELD INSTALLATION

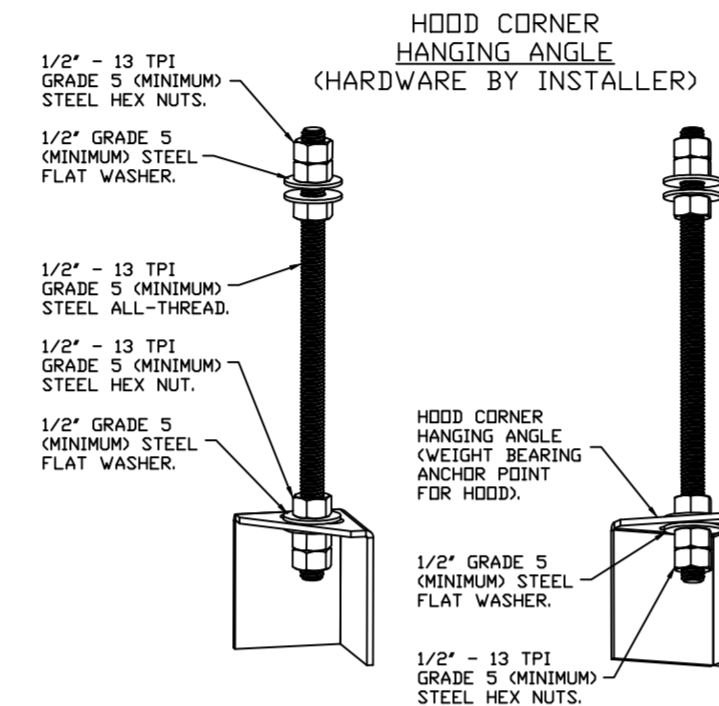

ASSEMBLY INSTRUCTIONS

HANGING ANGLE MUST BE SUPPORTED WITH 1/2" - 13 TPI GRADE 5 (MINIMUM) ALL-THREAD, SANDWICH HANGING ANGLES AND CEILING ANCHOR POINTS WITH 1/2" GRADE 5 (MINIMUM) STEEL FLAT WASHERS AND 1/2" - 13 TPI GRADE 5 (MINIMUM) HEX NUTS AS SHOWN. MUST USE DOUBLED HEX NUT CONFIGURATION BENEATH HOOD HANGING ANGLES AND ABOVE CEILING ANCHORS. MAINTAIN 1/4" OF EXPOSED THREADS BENEATH BOTTOM HEX NUT. TORQUE ALL HEX NUTS TO 57 FT-LBS.

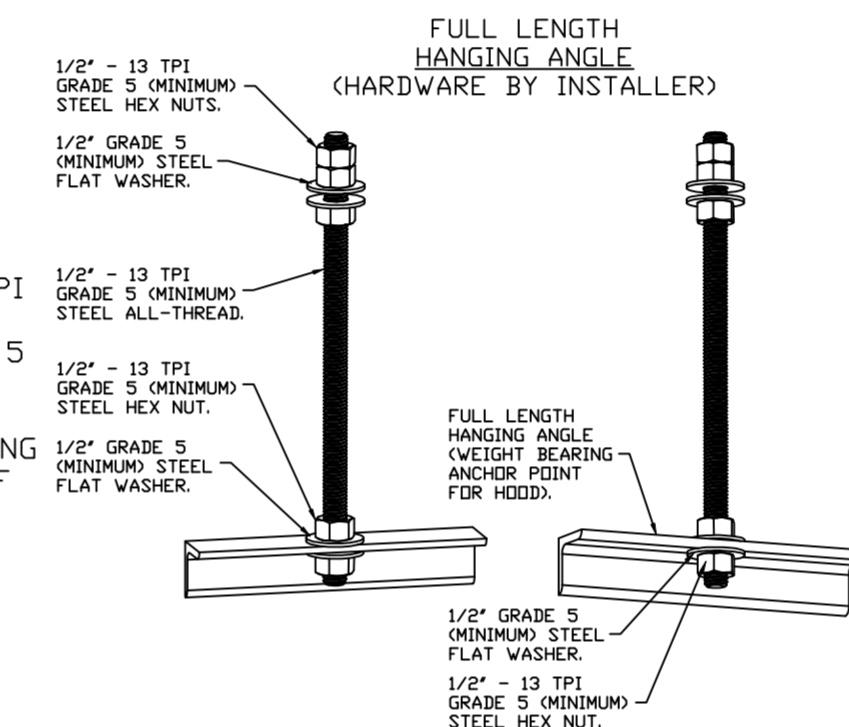

ASSEMBLY INSTRUCTIONS

HANGING ANGLE MUST BE SUPPORTED WITH 1/2" - 13 TPI GRADE 5 (MINIMUM) ALL-THREAD, SANDWICH HANGING ANGLES AND CEILING ANCHOR POINTS WITH 1/2" GRADE 5 (MINIMUM) STEEL FLAT WASHERS AND 1/2" - 13 TPI GRADE 5 (MINIMUM) HEX NUTS AS SHOWN. MUST USE DOUBLED HEX NUT CONFIGURATION ABOVE CEILING ANCHORS. SINGLE HEX NUT BENEATH HANGING ANGLE IS ACCEPTABLE FOR FULL LENGTH HANGING ANGLES. MAINTAIN 1/4" OF EXPOSED THREADS BENEATH BOTTOM HEX NUT. TORQUE ALL HEX NUTS TO 57 FT-LBS.

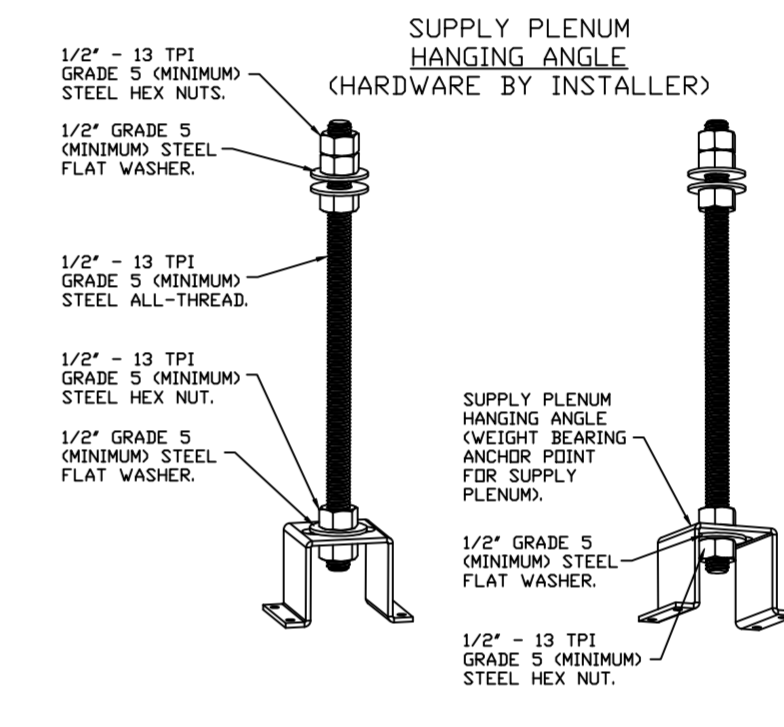

ASSEMBLY INSTRUCTIONS

HANGING ANGLE MUST BE SUPPORTED WITH 1/2" - 13 TPI GRADE 5 (MINIMUM) ALL-THREAD, SANDWICH HANGING ANGLES AND CEILING ANCHOR POINTS WITH 1/2" GRADE 5 (MINIMUM) STEEL FLAT WASHERS AND 1/2" - 13 TPI GRADE 5 (MINIMUM) HEX NUTS AS SHOWN. MUST USE DOUBLED HEX NUT CONFIGURATION ABOVE CEILING ANCHORS. SINGLE HEX NUT BENEATH HANGING ANGLE IS ACCEPTABLE FOR PSP HANGING ANGLES. MAINTAIN 1/4" OF EXPOSED THREADS BENEATH BOTTOM HEX NUT. TORQUE ALL HEX NUTS TO 57 FT-LBS.

REVISIONS

| DESCRIPTION | DATE |
|-------------|------|
| | |
| | |
| | |
| | |

CAPTIVEAIRE

Highwoods Group
www.captiveaire.com

4641 Paragon Park Rd., Raleigh, NC 27616 PHONE: (919) 875-0420 FAX: (919) 875-0577 EMAIL: reg40@captiveaire.com

CHIPOTLE NORTHEAST #4649
NORTH EAST, MD, 21901

DATE: 4/11/2023
DWG.#: 5945450
DRAWN BY: JMB-40
SCALE: 3/4" = 1'-0"
MASTER DRAWING

SHEET NO. 1



FIRE SYSTEM INFORMATION - JOB#5945450

| FIRE SYSTEM NO | TAG | TYPE | SIZE | FLOW POINTS | INSTALLATION | |
|----------------|-----|------------|---------|-------------|-------------------|------------------|
| | | | | | SYSTEM | LOCATION ON HOOD |
| 1 | | ANSUL R102 | 3.0/3.0 | 15 | FIRE CABINET LEFT | LEFT, HOOD 1 |

GAS VALVE(S)

| FIRE SYSTEM NO | TAG | TYPE | SIZE | SUPPLIED BY |
|----------------|-----|------------|-------|---------------------|
| 1 | | MECHANICAL | 1.500 | CAPTIVEAIRE SYSTEMS |

REVISIONS

| DESCRIPTION | DATE |
|-------------|------|
| | |
| | |
| | |
| | |

CAPTIVEAIRE
Highwoods Group
www.captiveaire.com
4641 Paragon Park Rd., Raleigh, NC, 27616 PHONE: (919) 875-0420 FAX: (919) 875-0577 EMAIL: reg@captveaire.com

CHIPOTLE NORTHEAST #4649
NORTH EAST, MD, 21901

DATE: 4/11/2023
DWG.#: 5945450
DRAWN BY: JMB-40
SCALE: 3/4" = 1'-0"
MASTER DRAWING

SHEET NO.
2

EXHAUST FAN INFORMATION – JOB#5945450

| FAN UNIT NO | TAG | QTY | FAN UNIT MODEL # | MANUFACTURER | CFM | ESP | RPM | MOTOR ENCL | HP | BHP | PHASE | VOLT | FLA | DISCHARGE VELOCITY | WEIGHT (LBS) | SDNES |
|-------------|------|-----|------------------|--------------|------|-------|------|-------------|-------|--------|-------|------|-----|--------------------|--------------|-------|
| 1 | EF-1 | 1 | DUI80HFA | CAPTIVEAIRE | 2550 | 1.450 | 1220 | DDP,PREMIUM | 2.000 | 1.2800 | 3 | 208 | 8.3 | 589 FPM | 183 | 16.6 |
| 2 | EF-2 | 1 | DR12HFA | CAPTIVEAIRE | 150 | 0.600 | 1282 | TEAD-ECM | 0.250 | 0.0940 | 1 | 115 | 2.9 | | 50 | 6.1 |

MUA FAN INFORMATION – JOB#5945450

| FAN UNIT NO | TAG | QTY | FAN UNIT MODEL # | BLOWER | HOUSING | MIN CFM | DESIGN CFM | ESP | RPM | MOTOR ENCL | HP | BHP | PHASE | VOLT | FLA | MCA | MOCP | WEIGHT (LBS) | SDNES |
|-------------|-------|-----|------------------|------------|----------|---------|------------|-------|------|-------------|-------|--------|-------|------|-----|------|------|--------------|-------|
| 3 | MAU-1 | 1 | A1-D.250-15D | 15MF-1-MDD | A1-D.250 | 1000 | 1300 | 0.500 | 1546 | DDP,PREMIUM | 1.000 | 0.5680 | 3 | 208 | 3.1 | 3.9A | 15A | 495 | 12.1 |

GAS FIRED MAKE-UP AIR UNIT(S)

| FAN UNIT NO | TAG | INPUT BTUs | OUTPUT BTUs | TEMP RISE | REQUIRED INPUT GAS PRESSURE | GAS TYPE | BURNER EFFICIENCY(%) |
|-------------|-------|------------|-------------|-----------|-----------------------------|----------|----------------------|
| 3 | MAU-1 | 88977 | 81859 | 59°F | 7 IN. W.C. - 14 IN. W.C. | NATURAL | 92 |

FAN OPTIONS

| FAN UNIT NO | TAG | QTY | DESCRIPTION |
|-------------|-----------------------|-----|--|
| 1 | EF-1 | 1 | GREASE BOX |
| | | 1 | 2 YEAR PARTS WARRANTY |
| 2 | EF-2 | 1 | 1 12-BDD DAMPER |
| | | 1 | ECM WIRING PACKAGE – MANUAL OR 0-10VDC REFERENCE SPEED CONTROL –RTC- (TELCO MOTOR), CCW ROTATION |
| 3 | MAU-1 | 1 | 2 YEAR PARTS WARRANTY |
| | | 1 | SIZE 1 TEMPERED COMMERCIAL DOWN DISCHARGE FOR DIRECT DRIVE AHUS |
| | | 1 | INLET PRESSURE GAUGE, 0-35" |
| | | 1 | MANIFOLD PRESSURE GAUGE, -5 TO 15" WC |
| | | 1 | SHIP LOOSE GAS STRAINER 3/4" |
| | | 1 | MOTORIZED BACKDRAFT DAMPER FOR A1-D HOUSING – MEETS AMCA CLASS 1A RATING |
| | | 1 | SEPARATE 120V WIRING PACKAGE (REQUIRED AND USED ONLY FOR DCV OR PREWIRE WITH VFD) – THREE PHASE ONLY |
| 1 | 2 YEAR PARTS WARRANTY | | |

FAN ACCESSORIES

| FAN UNIT NO | TAG | EXHAUST | | | | SUPPLY | | |
|-------------|-------|------------|----------------|------------|----------------|----------------|------------------|------------|
| | | GREASE CUP | GRAVITY DAMPER | WALL MOUNT | SIDE DISCHARGE | GRAVITY DAMPER | MOTORIZED DAMPER | WALL MOUNT |
| 1 | EF-1 | YES | | | | | | |
| 2 | EF-2 | | YES | | | | | |
| 3 | MAU-1 | | | | | | YES | |

CURB ASSEMBLIES

| NO | ON FAN | TAG | WEIGHT | ITEM | SIZE |
|----|--------|-------|--------|------|--|
| 1 | # 1 | EF-1 | 37 LBS | CURB | 26.500"W X 26.500"L X 20.000"H ALONG LENGTH, RIGHT VENTED. |
| 2 | # 2 | EF-2 | 31 LBS | CURB | 17.500"W X 17.500"L X 26.000"H ALONG LENGTH, RIGHT. |
| 3 | # 3 | MAU-1 | 65 LBS | CURB | 21.000"W X 71.000"L X 20.000"H ALONG WIDTH, RIGHT INSULATED. |

FAN #1 DUI80HFA – EXHAUST FAN (EF-1)

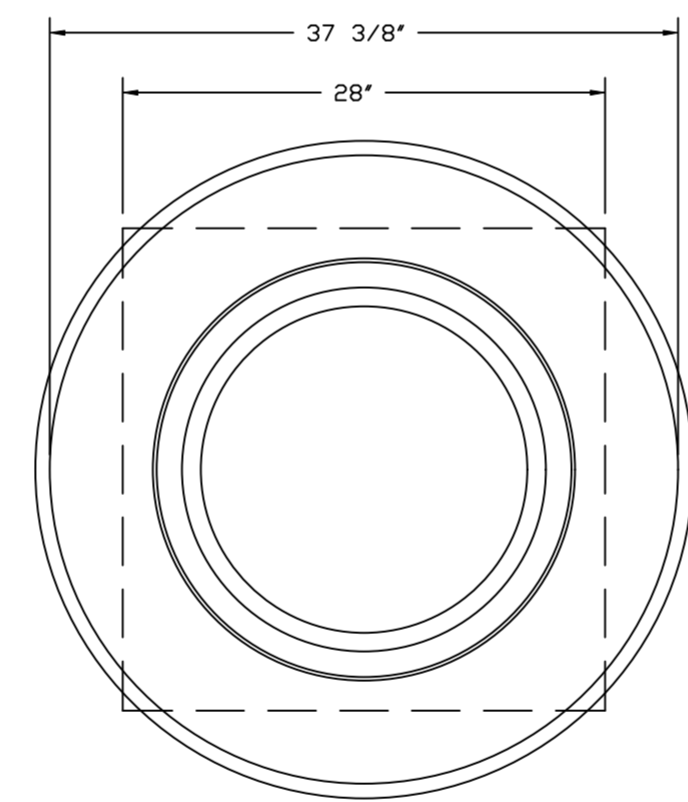
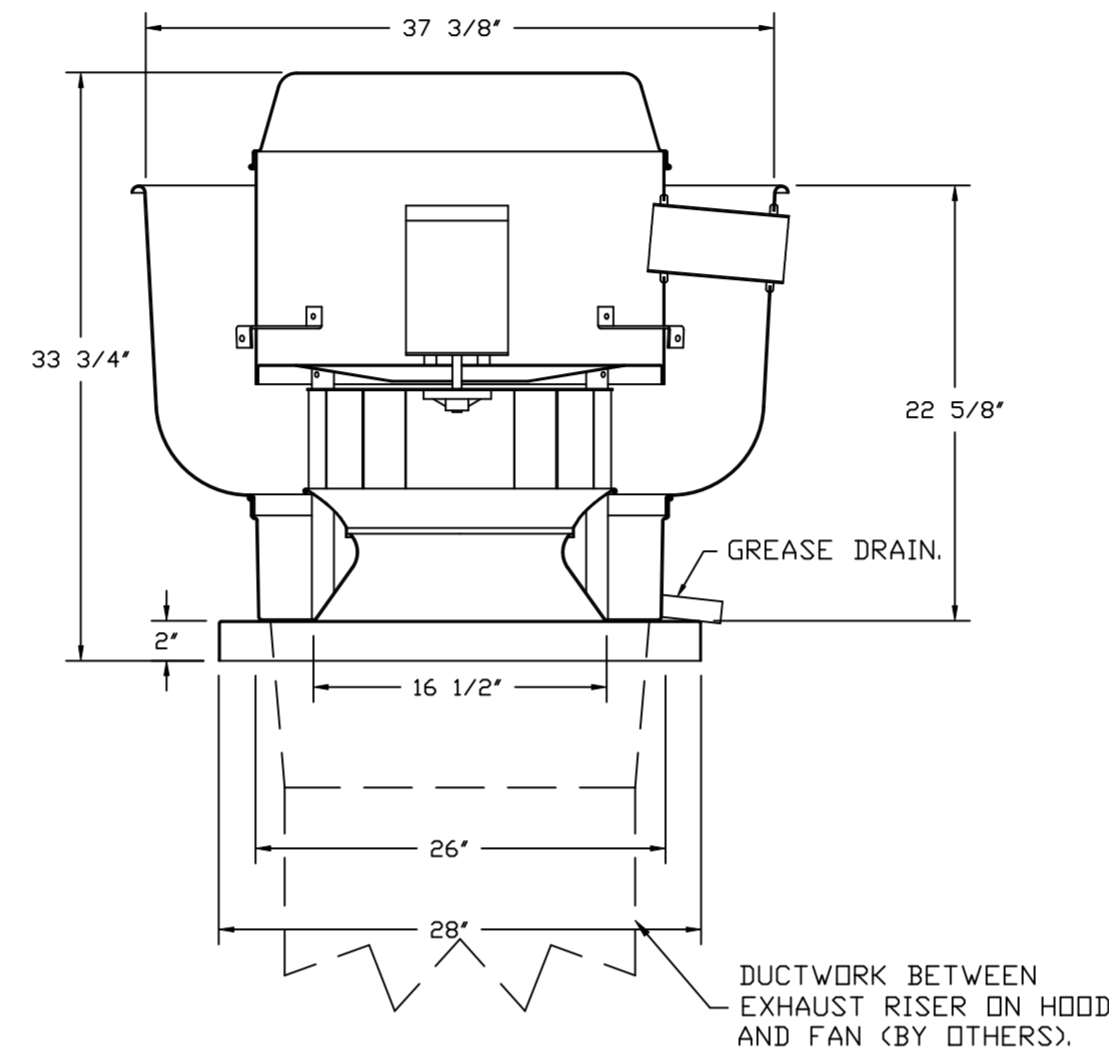

TOP VIEW

FEATURES:

- DIRECT DRIVE CONSTRUCTION (NO BELTS/PULLEYS).
- ROOF MOUNTED FANS.
- RESTAURANT MODEL.
- UL705 AND UL762 AND ULC-S645
- VARIABLE SPEED CONTROL.
- INTERNAL WIRING.
- THERMAL OVERLOAD PROTECTION (SINGLE PHASE).
- HIGH HEAT OPERATION 300°F (149°C).
- GREASE CLASSIFICATION TESTING.
- NEMA 3R SAFETY DISCONNECT SWITCH.

NORMAL TEMPERATURE TEST

EXHAUST FAN MUST OPERATE CONTINUOUSLY WHILE EXHAUSTING AIR AT 300°F (149°C) UNTIL ALL FAN PARTS HAVE REACHED THERMAL EQUILIBRIUM, AND WITHOUT ANY DETERIORATING EFFECTS TO THE FAN WHICH WOULD CAUSE UNSAFE OPERATION.

ABNORMAL FLARE-UP TEST

EXHAUST FAN MUST OPERATE CONTINUOUSLY WHILE EXHAUSTING BURNING GREASE VAPORS AT 600°F (316°C) FOR A PERIOD OF 15 MINUTES WITHOUT THE FAN BECOMING DAMAGED TO ANY EXTENT THAT COULD CAUSE AN UNSAFE CONDITION.

OPTIONS

- GREASE BOX.
- 2 YEAR PARTS WARRANTY.

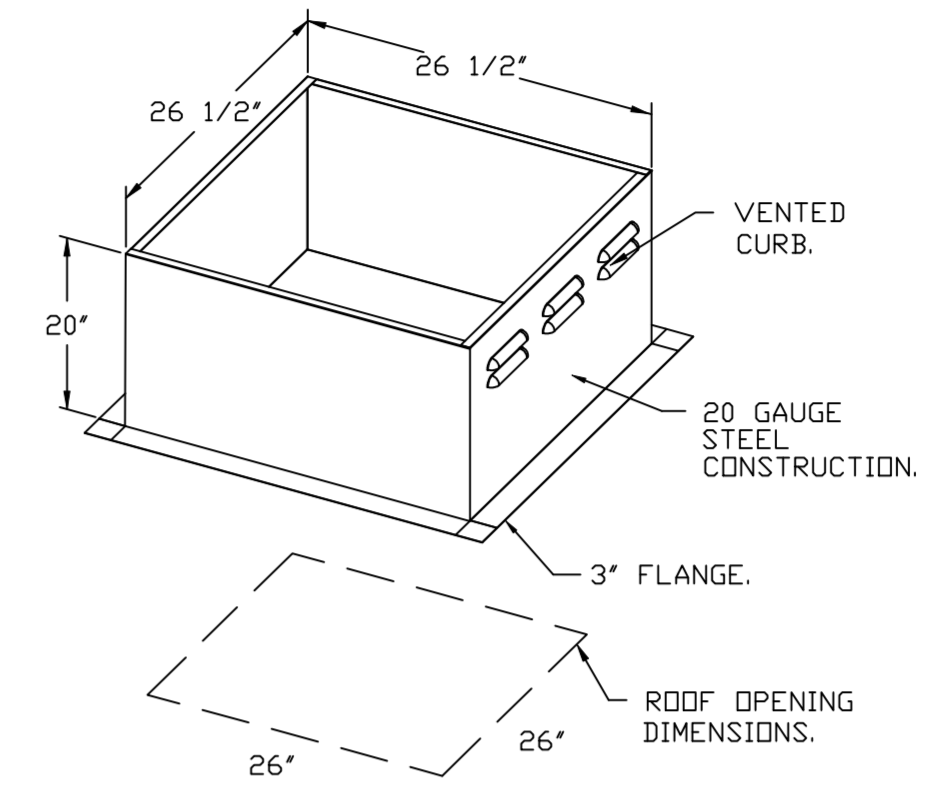

REVISIONS

| DESCRIPTION | DATE: |
|-------------|-------|
| | |
| | |
| | |
| | |

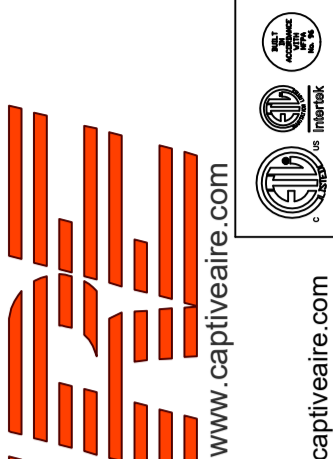

CAPTIVE AIR
Highwoods Group
4641 Paragon Park Rd., Raleigh, NC, 27616 PHONE: (919) 875-0420 FAX: (919) 875-0577 EMAIL: reg@captivair.com

CHIPOTLE NORTHEAST #4649
NORTH EAST, MD, 21901

DATE: 4/11/2023

DWG.#: 5945450

DRAWN BY: JMB-40

SCALE: 3/4" = 1'-0"

MASTER DRAWING

SHEET NO.

FAN #2_DR12HFA - EXHAUST FAN (CF-22)

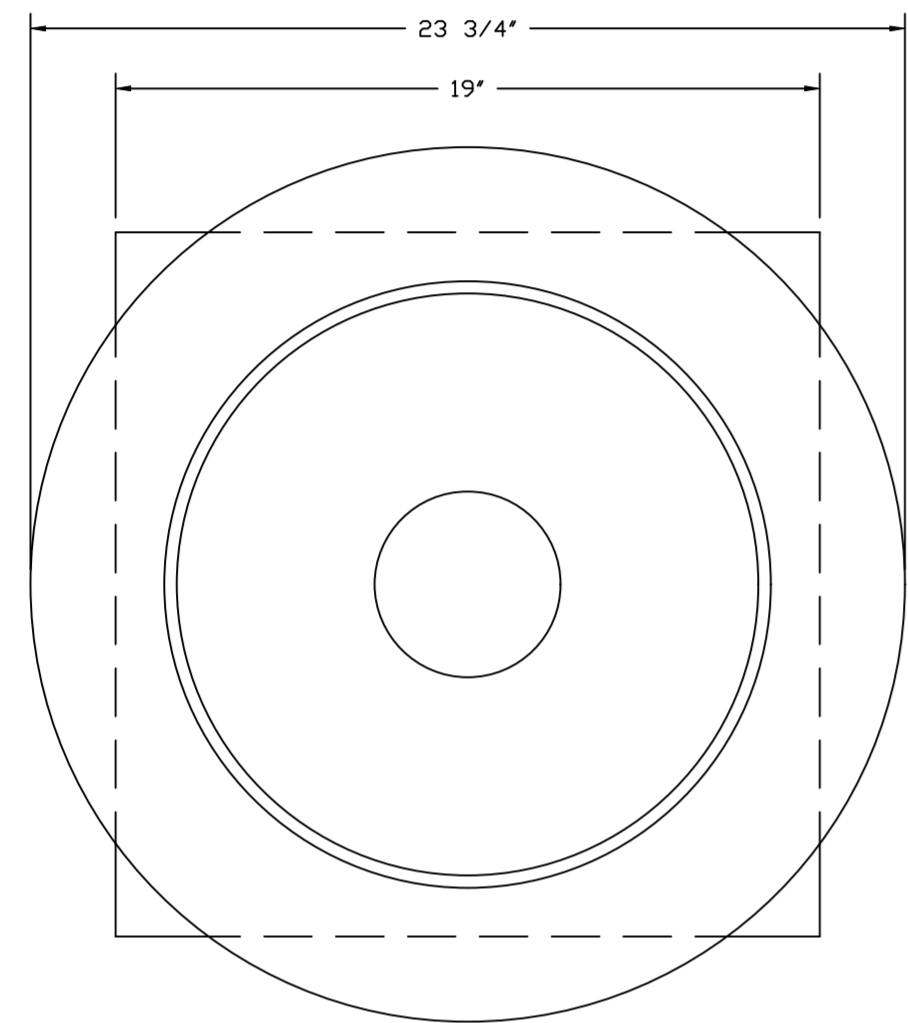
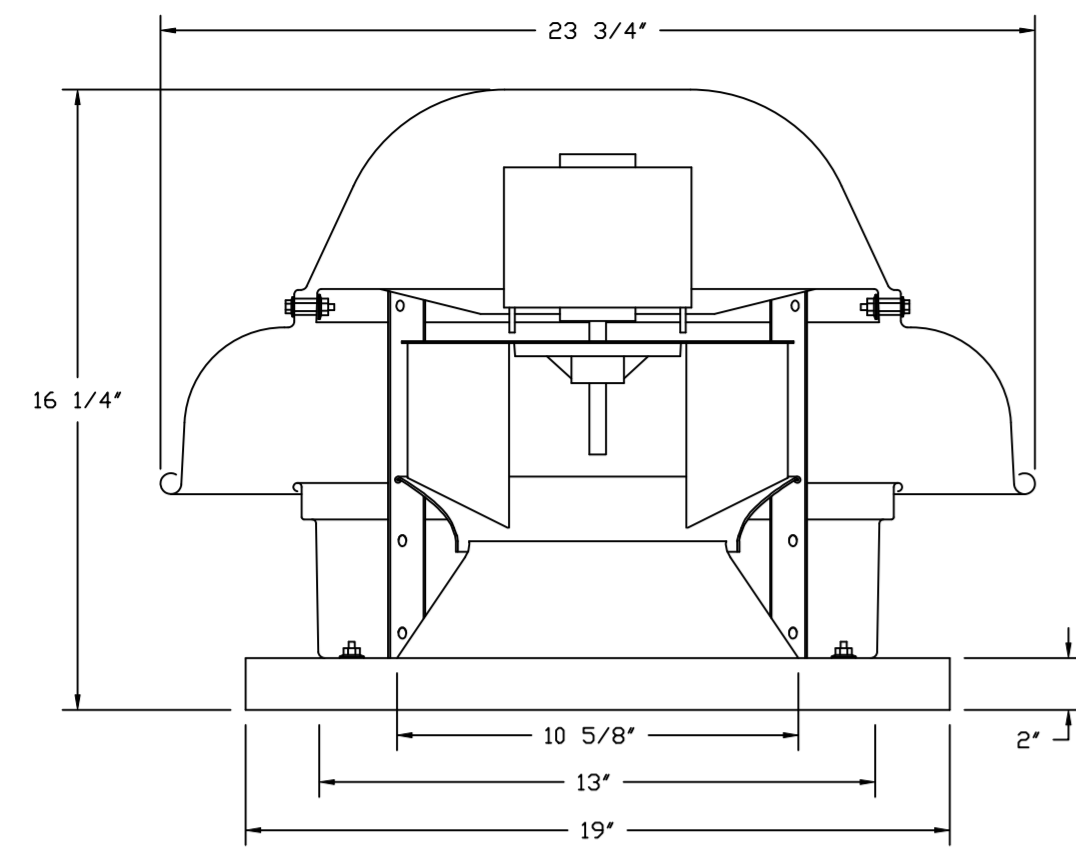

TOP VIEW

FEATURES:

- DIRECT DRIVE CONSTRUCTION (NO BELTS/PULLEYS).
- ROOF MOUNTED FANS.
- UL705.
- SAFETY DISCONNECT.
- STANDARD BIRD SCREEN.
- SPEED CONTROL.
- THERMAL OVERLOAD PROTECTION (SINGLE PHASE).

OPTIONS:

- I 12-BDD DAMPER.
- ECM WIRING PACKAGE - MANUAL OR 0-10VDC REFERENCE SPEED CONTROL.
- RTC - (THERM MOTOR), CCW ROTATION.
- 2 YEAR PARTS WARRANTY.

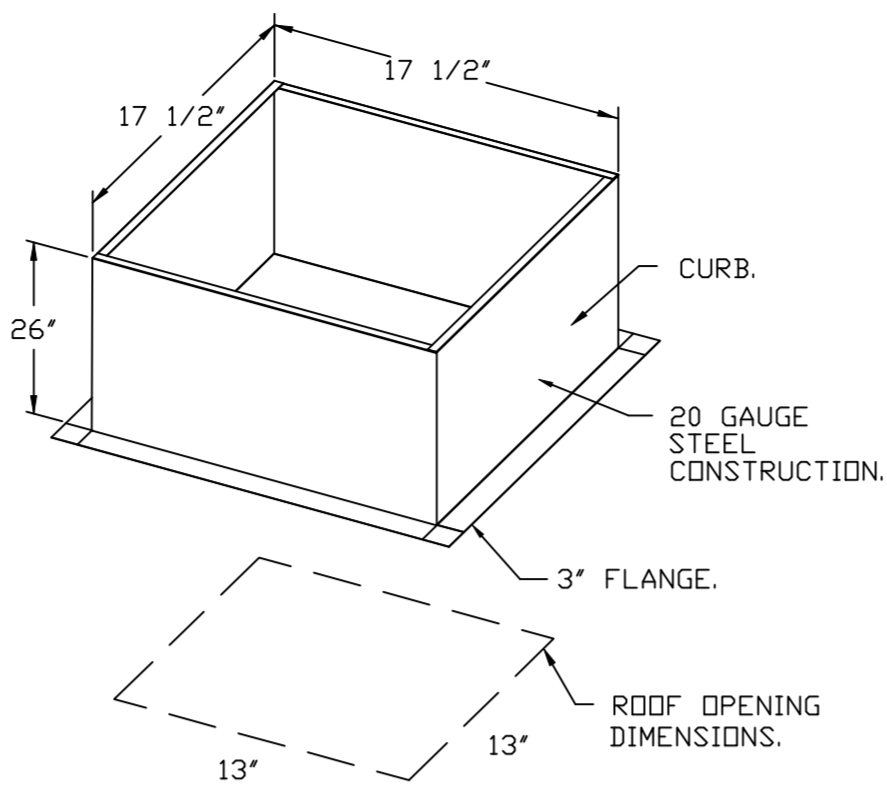

BACKDRAFT DAMPER INSTALLATION

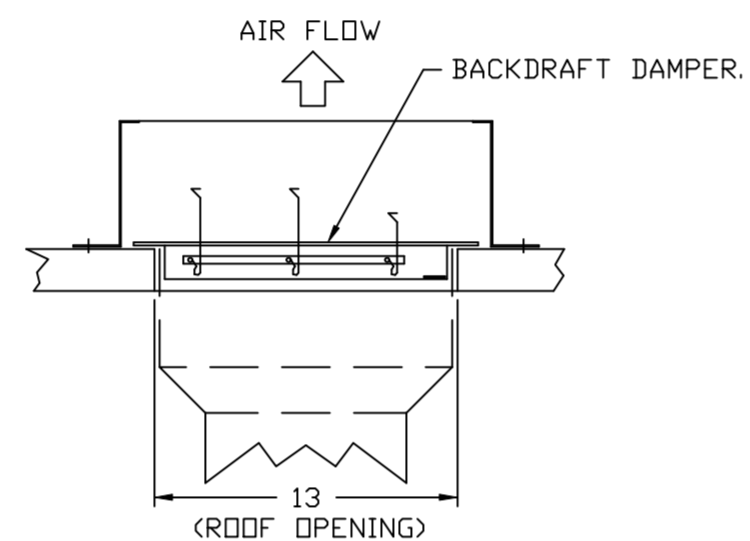

REVISIONS

| DESCRIPTION | DATE: |
|-------------|-------|
| | |
| | |
| | |
| | |

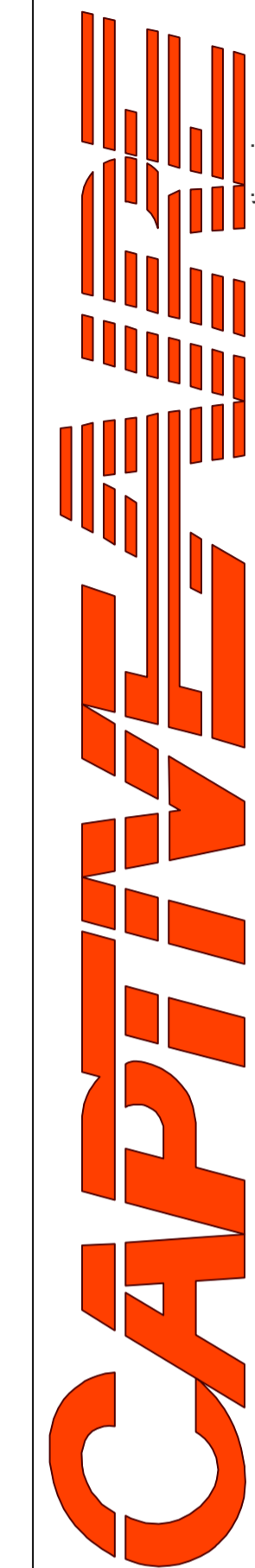
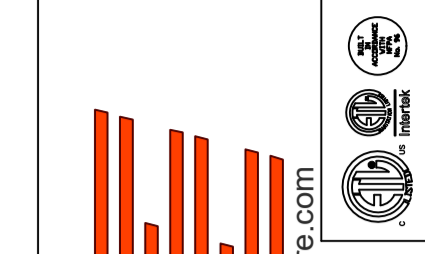

www.captiveair.com
reg10@captiveair.com

Highwoods Group
4641 Paragon Park Rd., Raleigh, NC, 27616 PHONE: (919) 875-0420 FAX: (919) 875-0577 EMAIL: reg10@captiveair.com

CHIPOTLE NORTHEAST #4649
NORTH EAST, MD, 21901

DATE: 4/11/2023

DWG.#: 5945450

DRAWN BY: JMB-40

SCALE: 3/4" = 1'-0"

MASTER DRAWING

SHEET NO. 4

- FAN #3 AI-D250-15D - HEATER (MAU-1)
1. DIRECT GAS FIRED HEATED MAKE UP AIR UNIT WITH 15' MIXED FLOW DIRECT DRIVE FAN.
 2. INTAKE HOOD WITH EZ FILTERS.
 3. DOWN DISCHARGE - AIR FLOW RIGHT -> LEFT.
 4. DOWN DISCHARGE CONSTRUCTION FOR SIZE 1 DIRECT DRIVE AHUS.
 5. GAS PRESSURE GAUGE, 0-35", 2.5" DIAMETER, 1/4" THREAD SIZE.
 6. GAS PRESSURE GAUGE, -5 TO +15 INCHES WC, 2.5" DIAMETER, 1/4" THREAD SIZE.
 7. SHIP LOOSE GAS STRAINER, TO BE INSTALLED UPSTREAM OF UNIT CONNECTION, 3/4" CONNECTION.
 8. MOTORIZED BACK DRAFT DAMPER 16" X 18" FOR SIZE 1 STANDARD & MODULAR HEATER UNITS W/EXTENDED SHAFT, STANDARD GALVANIZED CONSTRUCTION, 3/4" REAR FLANGE, LOW LEAKAGE, TFB220S ACTUATOR INCLUDED.
 9. SEPARATE 120VAC WIRING PACKAGE FOR MAKE-UP AIR UNITS. OPTION MUST BE SELECTED WHEN MOUNTING VFD IN PREWIRE PANEL OR WITH DCV PACKAGE. PROVIDES SEPARATE 120VAC INPUT TO SUPPLY FAN. THIS 120V SIGNAL MUST BE RUN BY ELECTRICIAN FROM DCV TO MUA SWITCH.
 10. HINGED DOUBLE WALL INSULATED DDDR ASSEMBLY (BURNER/BLOWER SECTION).
 11. 2 YEAR PARTS WARRANTY

*NOTE: SUPPLY DUCT MUST BE INSTALLED TO MEET SMACNA STANDARDS. A MINIMUM STRAIGHT DUCT LENGTH MUST BE MAINTAINED DOWNSTREAM OF UNIT DISCHARGE AS OUTLINED IN AMCA PUBLICATION 201. WHEN USING RECTANGULAR DUCTWORK, ELBOWS MUST BE RADIUS THROAT, RADIUS BACK WITH TURNING VANES. FLEXIBLE DUCTWORK AND SQUARE THROAT/SQUARE BACK ELBOWS SHOULD NOT BE USED. ANY TRANSITION AND/OR TURNS IN THE DUCTWORK WILL CAUSE SYSTEM EFFECT. SYSTEM EFFECT WILL DRASTICALLY INCREASE STATIC PRESSURE AND REDUCE AIRFLOW. DO NOT RELY ON UNIT TO SUPPORT DUCT IN ANY WAY. FAILURE TO PROPERLY SIZE DUCTWORK MAY CAUSE SYSTEM EFFECTS AND REDUCE PERFORMANCE OF THE EQUIPMENT. SUGGESTED STRAIGHT DUCT SIZE IS 14" x 14".

SUPPLY SIDE HEATER INFORMATION:

WINTER TEMPERATURE = 16°F. TEMP. RISE = 59°F.
 BTUS CALCULATED OFF ACTUAL AIR DENSITY.
 OUTPUT BTUS AT ALTITUDE OF 0.0 FT. = 81942.
 INPUT BTUS AT ALTITUDE OF 0.0 FT. = 89067.
 OUTPUT BTUS AT ALTITUDE OF 28 FT. = 81859.
 INPUT BTUS AT ALTITUDE OF 28 FT. = 88977.

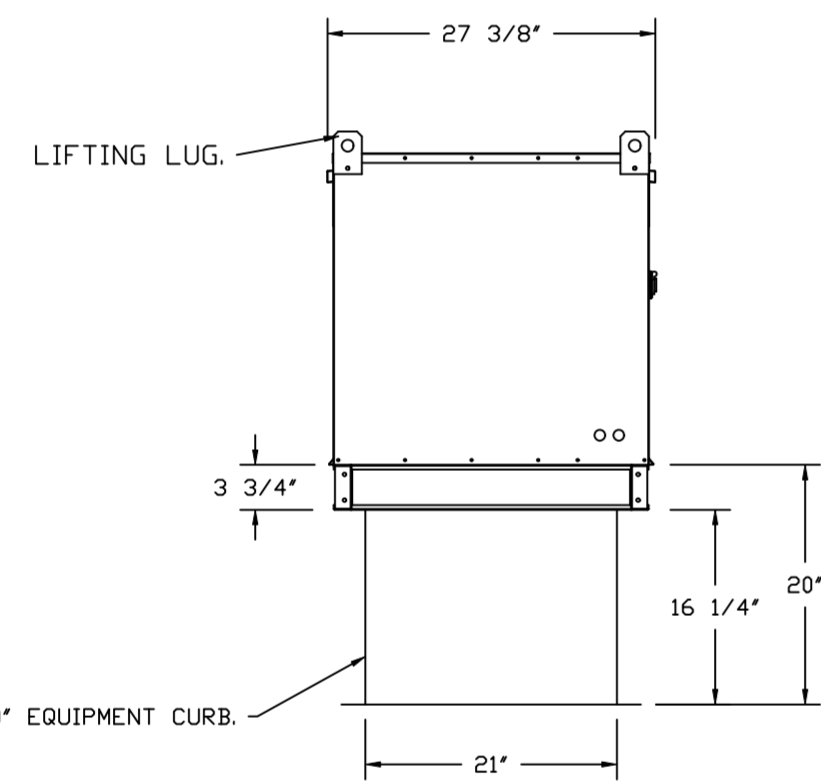
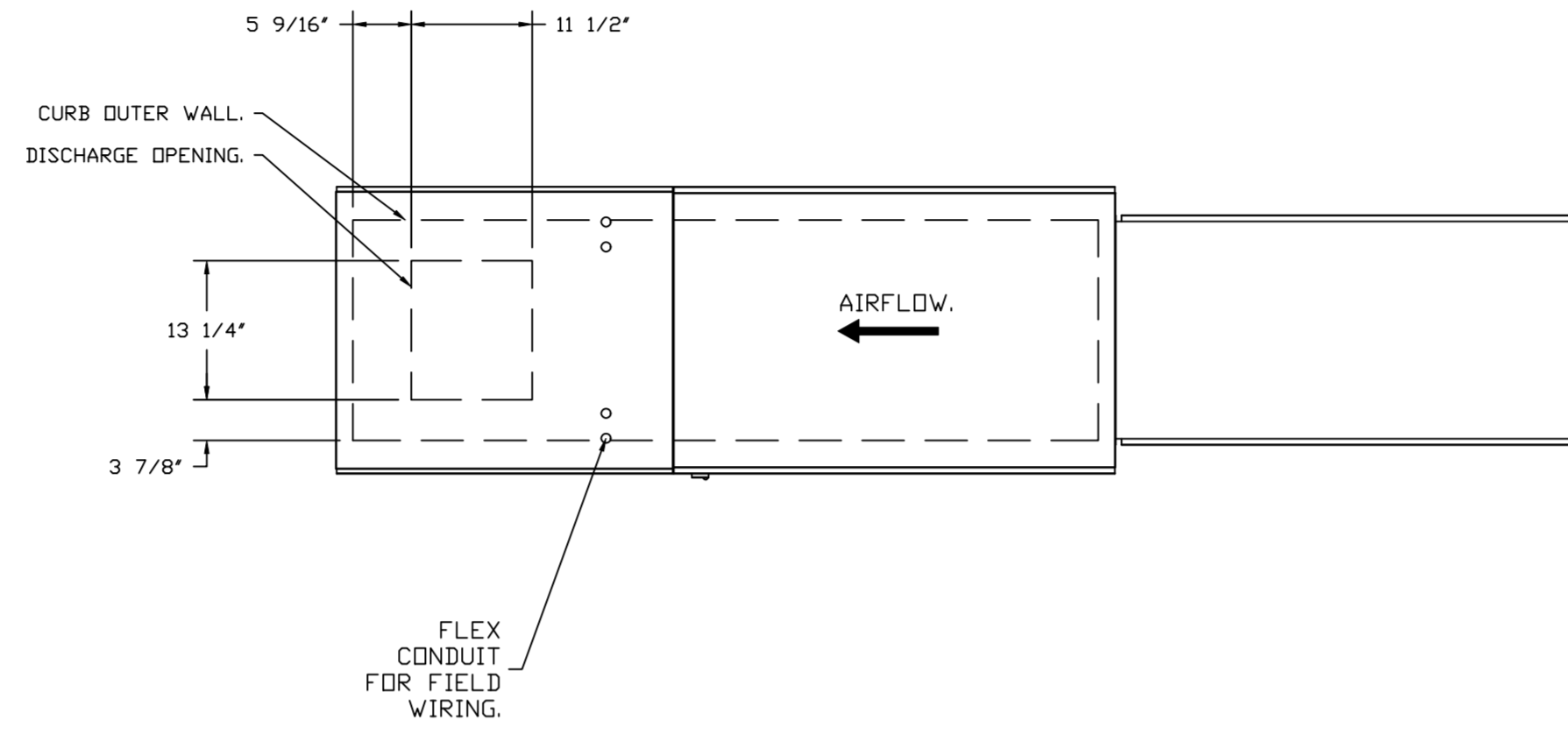

ROOF OPENING 2" SMALLER THAN CURB DIMENSION.

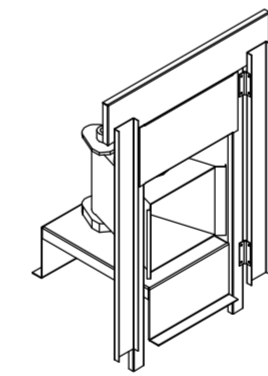
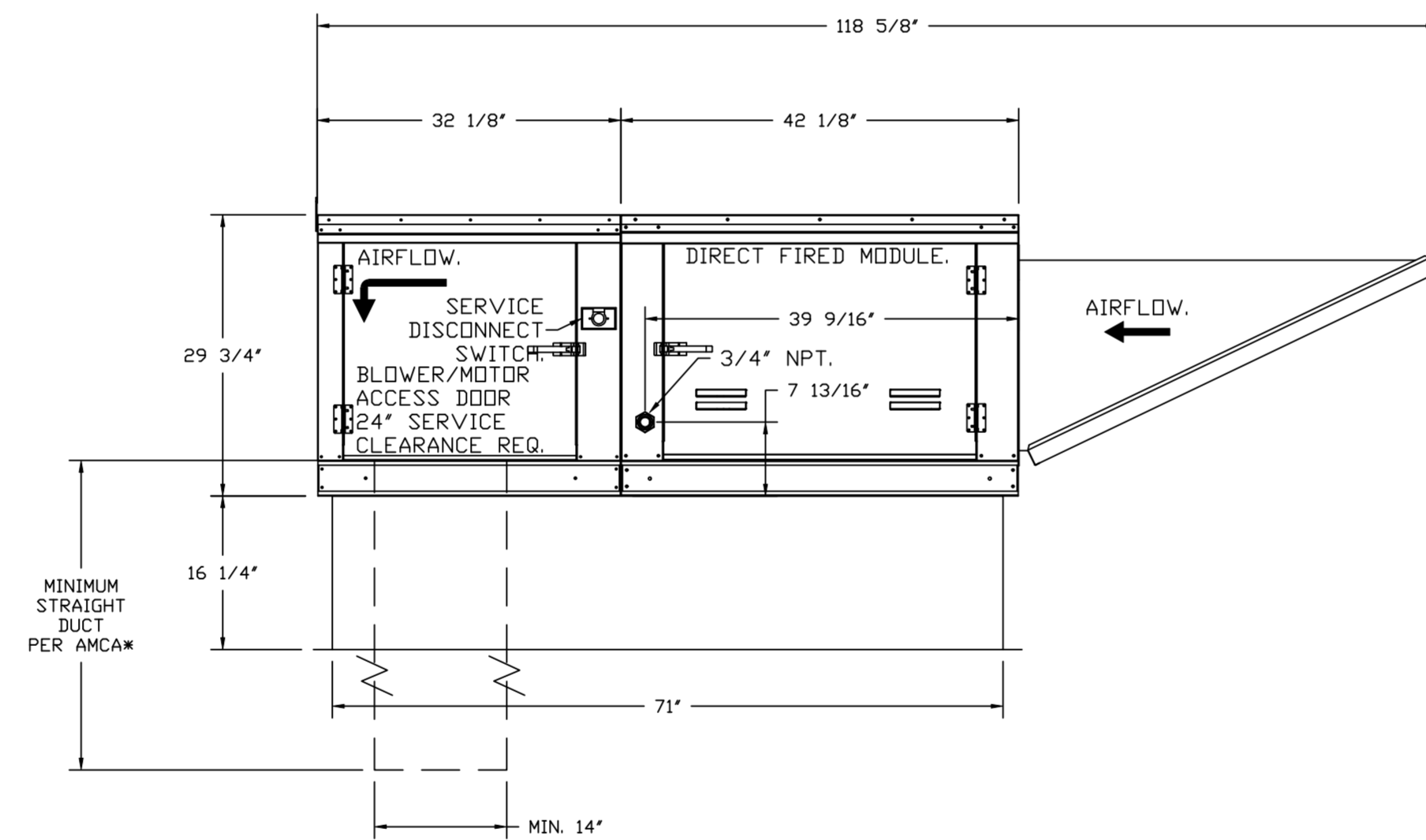

DIRECT FIRED (DF) PROFILE PLATE ASSEMBLY

DIRECT FIRED PROFILE PLATE SPECIFICATIONS:

DESCRIPTION:
 DIRECT FIRED BURNERS SHALL HAVE PATENTED (US PATENT NO. US6699508B0), SELF-ADJUSTING PROFILE PLATES DESIGNED TO ENSURE PROPER AIR VELOCITY AND PRESSURE DROP ACROSS THE BURNER. PROFILE PLATES SHALL ALLOW BURNERS TO ACHIEVE CLEAN COMBUSTION BY LIMITING BY-PRODUCT LEVELS TO A MAXIMUM OF 50PPM OF CARBON MONOXIDE (CO), AND 50PPM OF NITROGEN DIOXIDE. DIRECT FIRED UNITS SHALL BE CONFIGURED WITH THE BLOWER MOUNTED DOWNSTREAM OF THE BURNER. THIS ARRANGEMENT WILL ENSURE A CONSISTENT AIRFLOW, REGARDLESS OF INLET AIR TEMPERATURE.

APPLICATION:
 SPRING-LOADED BURNER PROFILE PLATES ARE ENGINEERED TO AUTOMATICALLY REACT TO THE MOMENTUM OF A FRESH AIR STREAM, WITHOUT THE NEED FOR ANY MOTORS OR ACTUATORS TO MECHANICALLY ADJUST THEM. WITH THIS FEATURE, ALL DF UNITS ARE DESIGNED FOR DEMAND CONTROL VENTILATION (DCV) REQUIREMENTS.

CERTIFICATIONS:
 ALL PROFILE PLATE ASSEMBLIES SHALL BE INCLUDED IN THE DF UNIT'S ETL LISTING AND COMPLY WITH COMBINED SAFETY STANDARDS ANSI Z83.4 AND CSA 3.7 (NON-RECIRCULATING DF HEATERS) AND ANSI Z83.8 (RECIRCULATING DF HEATERS).

GENERAL CONSTRUCTION:
 -PROFILE PLATES SHALL BE FORMED FROM G90 GALVANIZED STEEL.
 -PROFILE PLATES SHALL VARY IN SIZE PER UNIT.
 -PROFILE PLATES SHALL BE MOUNTED ALONG THE SAME PLANE AS THE DISCHARGE OF THE BURNER.
 -DESIGN SHALL INCORPORATE PROPERLY TORQUED, PERMANENTLY MOUNTED SPRING HINGES.
 -SPRING HINGES SHALL BE MADE FROM PLATED STEEL.

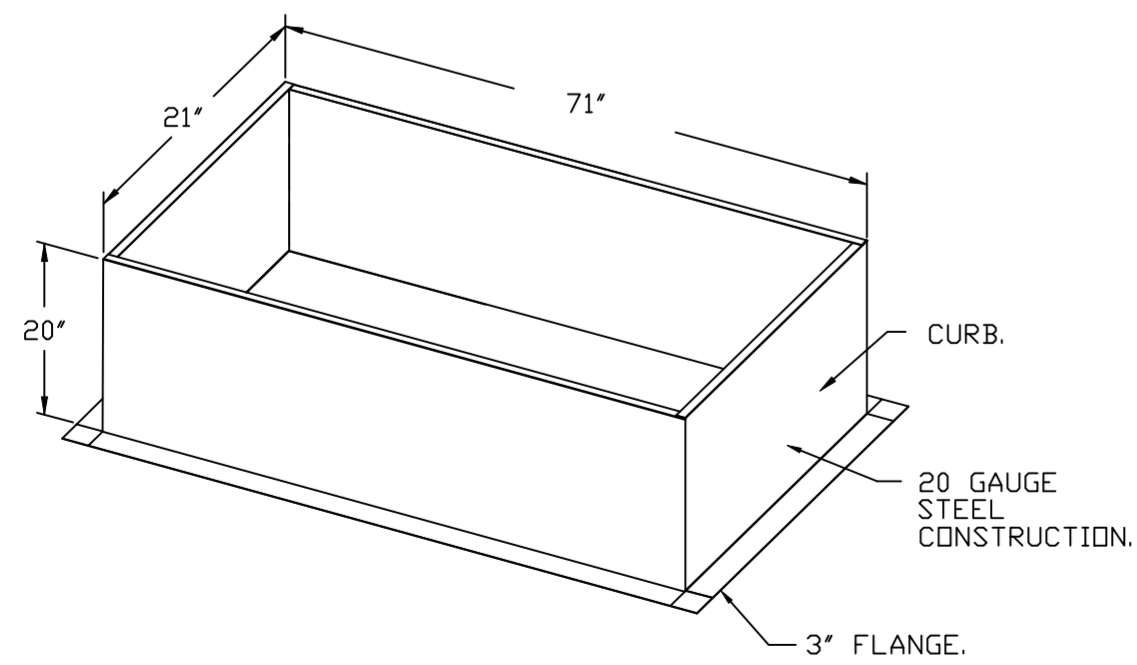

REVISIONS

| DESCRIPTION | DATE |
|-------------|------|
| | |
| | |
| | |
| | |

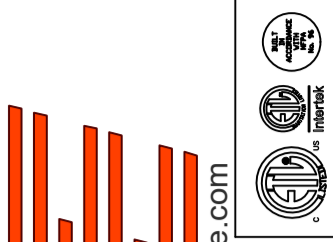

www.captiveaire.com
 www.captiveaire.com



Highwoods Group

4641 Paragon Park Rd., Raleigh, NC, 27616 PHONE: (919) 875-0420 FAX: (919) 875-0577 EMAIL: reg10@captiveaire.com

CHIPOTLE NORTHEAST #4649
 NORTH EAST, MD, 21901

DATE: 4/11/2023

DWG.#:
5945450

DRAWN BY:
JMB-40

SCALE:
3/4" = 1'-0"

MASTER DRAWING

SHEET NO.

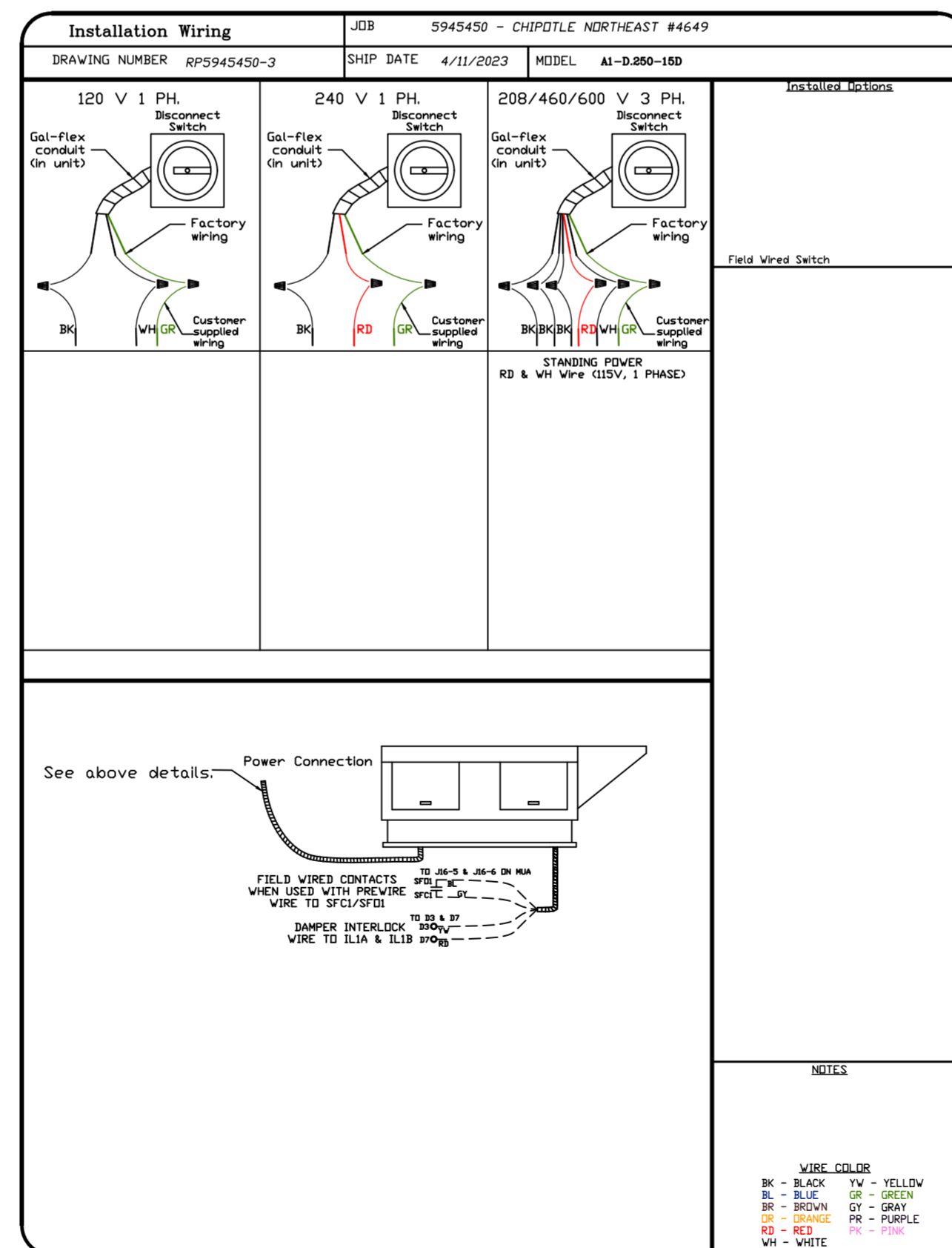
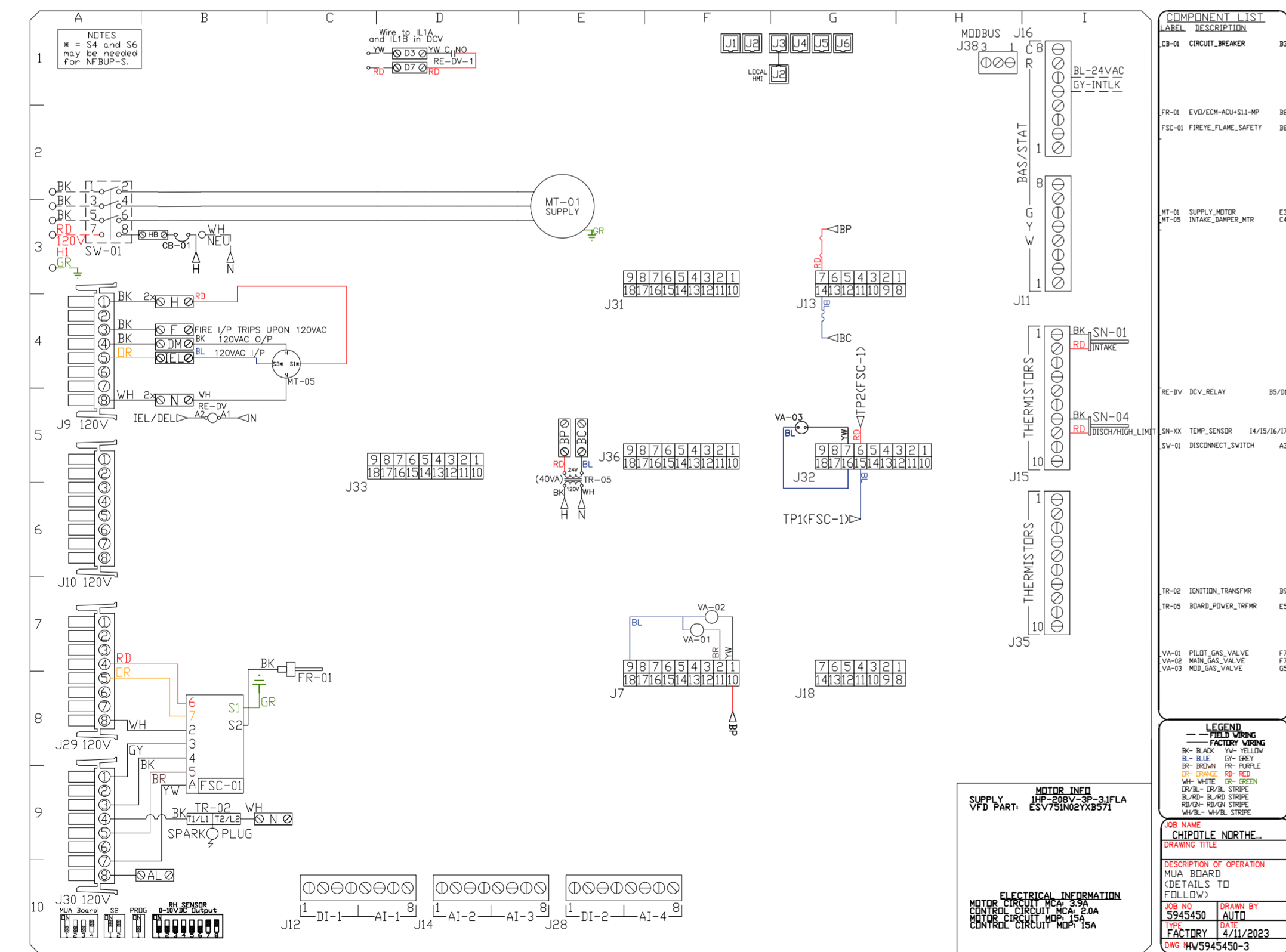
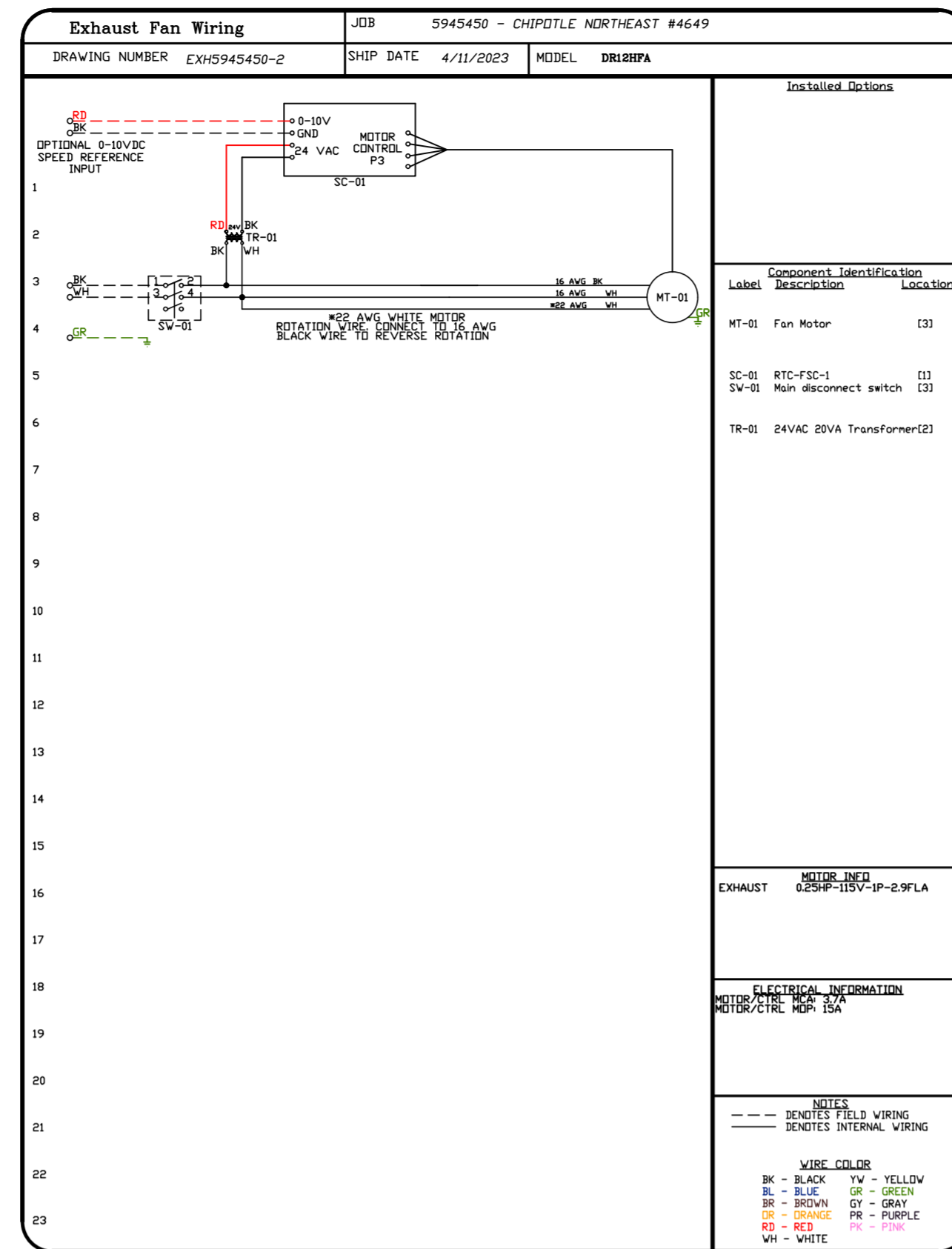
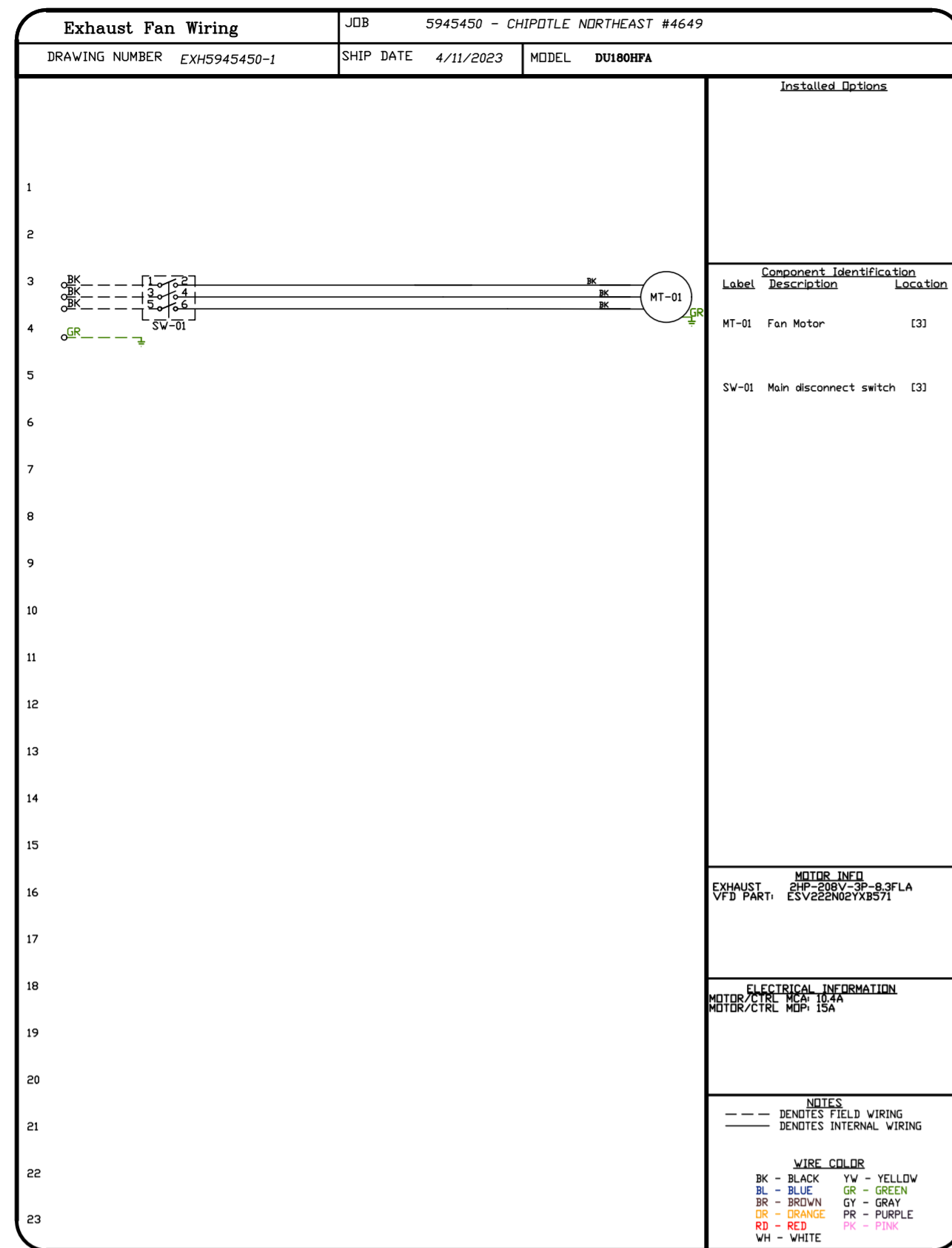

| REVISIONS | |
|-------------|------|
| DESCRIPTION | DATE |
| | |
| | |
| | |
| | |

CAPTIVE

Highwoods Group

www.captiveair.com

4641 Paragon Park Rd., Raleigh, NC, 27616 PHONE: (919) 875-0420 FAX: (919) 875-0577 EMAIL: reg10@captiveair.com

CHIPOTLE NORTHEAST #4649

NORTH EAST, MD, 21901

DATE: 4/11/2023

DWG.#: 5945450

DRAWN BY: JMB-40

SCALE: 3/4" = 1'-0"

MASTER DRAWING

SHEET NO. 6

