

- GENERAL NOTES**
- ALL OUTDOOR AIR INTAKES BY MECHANICAL EQUIPMENT SHALL HAVE A MINIMUM 10'-0" HORIZONTAL CLEARANCE FROM THE DISCHARGE OF ANY EXHAUST FAN, COMBUSTION EXHAUST OR PLUMBING VENT.
  - PROVIDE VIBRATION ISOLATION DEVICES AND FLEXIBLE DUCT/PIPING CONNECTIONS TO ALL MOVING MACHINERY NOT INTERNALLY ISOLATED.
  - ELECTRICAL CONTRACTOR IS RESPONSIBLE FOR ALL ELECTRICAL WORK SHOWN ON THE MECHANICAL DRAWINGS.
  - GAS RISER PIPING ON EXTERIOR WALL OF BUILDING TO INCLUDE MOUNTING BRACKETS AND SHALL BE PAINTED TO MATCH EXTERIOR WALL COLOR WITH OIL-BASE SEMI-GLOSS ENAMEL PAINT (AS APPROVED BY LANDLORD).
  - GAS PIPING ON ROOF SHALL BE PAINTED "SAFETY YELLOW" WITH OIL-BASE SEMI-GLOSS ENAMEL PAINT (AS APPROVED BY LANDLORD).
  - ALL ROOF PENETRATIONS MUST BE PERFORMED, FLASHED, AND PATCHED BY LANDLORD'S ROOFING CONTRACTOR USING PROPER ROOF JACKS AS APPROVED BY LANDLORD.
  - PROVIDE ALL BLOCKING ON ROOF WITH SLIP SHEETS UNDERNEATH AS APPROVED BY LANDLORD.
  - ALL HVAC ROOFTOP EQUIPMENT SHALL BE LABELED WITH SPACE SUITE NUMBER AS APPROVED BY LANDLORD.

- KEYED NOTES**
- WEATHERPROOF DISCONNECT SWITCH TO ARRIVE FACTORY INSTALLED ON RTU.
  - ROUTE 2" GAS (0.5 PSI) DOWN TO KITCHEN EQUIPMENT. PROVIDE WEATHER TIGHT SEAL AT PIPE PENETRATION. REFER TO THE WATER AND GAS PLUMBING PLAN FOR CONTINUATION OF PIPING BELOW THE ROOF.
  - ROUTE 1-1/4" (0.5 PSI) GAS LINE DOWN TO WATER HEATER. INSTALLATION COMPLETE WITH SHUTOFF VALVE, REGULATOR, UNION, AND 6" DIRT LEG. PROVIDE WEATHER TIGHT SEAL AT PIPE PENETRATION. REFER TO WATER AND GAS PLUMBING PLAN FOR CONTINUATION OF PIPING BELOW ROOF.
  - WEATHERPROOF, GFCI, WEATHER-RATED OUTLET PROVIDED WITH RTU. CONDUIT AND WIRING TO RUN IN ATTIC SPACE AND UP IN ROOF CURB TO OUTLET ON RTU.
  - CONTRACTOR SHALL PROVIDE ALL ELECTRICAL CONNECTIONS, WIRING AND CONDUITS NECESSARY FOR THE INTERLOCKING OF KITCHEN EXHAUST FANS THROUGH THE KITCHEN CONTROL PANEL.
  - ELECTRICAL CONTRACTOR SHALL FIELD VERIFY RUN CONTROL WIRING TO ROOF TOP UNITS, SENSORS, AND THERMOSTATS. COORDINATE WITH MECHANICAL CONTRACTOR.
  - ROUTE 3/4" COLD WATER UP THROUGH THE ROOF AND CONNECT TO HOSE BIB. REFER TO THE WATER PLUMBING PLAN FOR CONTINUATION OF PIPING BELOW THE ROOF.
  - INSTALL WATER HEATER FLUE COMPLETE WITH MANUFACTURER AVAILABLE CONCENTRIC COMBUSTION AIR VENT FOR SINGLE ROOF PENETRATION. COORDINATE THE ROOF PENETRATION, FLASHING AND COUNTER-FLASHING WITH THE GENERAL CONTRACTOR AND LANDLORD APPROVED BONDED ROOFING CONTRACTOR. AVOID CONFLICTS WITH ROOF CRICKETS OR KICKER FRAMING.
  - ALL PIPING INSTALLED ON THE ROOF SHALL BE SUPPORTED WITH PRE-MANUFACTURED ADJUSTABLE PIPE SUPPORTS AT MAXIMUM 5'-0" ON CENTER AND EVERY CHANGE OF DIRECTION.
  - HVAC CONDENSATE DRAIN PIPING SHALL BE ROUTED DOWN THROUGH THE ROOF TO TERMINATION BELOW. REFER TO THE PLUMBING DWG PLAN FOR CONTINUATION OF CONDENSATE DRAINAGE PIPING BELOW THE ROOF.
  - ROUTE ELECTRICAL POWER FROM EXHAUST FAN THROUGH RESTROOM LIGHTING CONTROLLER. COORDINATE AND PROVIDE ALL REQUIRED RELAYS AND CONTACTORS TO CIRCUIT EXHAUST WITH LIGHTING CONTROLS.
  - PREFABRICATED ROOF JACK FOR REFRIGERATION PIPING AND POWER CONDUIT(S) SHALL BE PROVIDED BY THE GENERAL CONTRACTOR. REFER TO ARCHITECTURAL DETAILS FOR DIRECTION. THE MC, EC AND GC SHALL COORDINATE FOR A COMPLETE INSTALLATION.
  - CONDENSING UNIT SHALL BE INSTALLED ON SLEEPERS (AS APPROVED) BY THE MANUFACTURER. FIELD COORDINATE THE COMPLETE INSTALLATION.
  - ROOF MOUNTED VTR, SIZED AS SHOWN. INSTALLED LOCATION SHALL BE A MINIMUM OF 10'-0" HORIZONTALLY OR 3'-0" ABOVE VERTICALLY FROM ANY OUTDOOR AIR INTAKE.
  - CONDENSATE DRAIN PIPING FROM THE HVAC UNIT SHALL BE ROUTED ON THE ROOF AS SHOWN, AT A MINIMUM PITCH OF 1/4" PER FOOT IN THE DIRECTION OF FLOW. REFER TO THE PLUMBING DWG PLAN FOR CONTINUATION OF CONDENSATE DRAINAGE PIPING BELOW THE ROOF.
  - INTERWIRE SERVICE FROM COOLER RUN CONDUIT ABOVE CEILING. THESE ITEMS ARE NOT PRE-WIRED AND WILL REQUIRE CONNECTIONS BY ELECTRICIAN AND FIELD WIRING.
  - ROUTE NEW GAS LINE UP AND OVER PARAPET FROM NEW GAS METER AS (2.0 PSI). NEW GAS LOAD DEMAND OF (APPROX 1,893 CFH). COORDINATE ALL METER, PRESSURE REGULATOR & CONNECTIONS AND REQUIREMENTS WITH THE LOCAL GAS PROVIDER. CONTRACTOR TO VERIFY FIELD CONDITIONS BEFORE CONSTRUCTION.
  - PROVIDE EXHAUST VENT ROOF CAP LOREN COOK PR-8 OR SIMILAR. INSTALL COMPLETE WITH MANUFACTURER AVAILABLE ROOF CURB, BACKDRAFT DAMPER, AND BIRDSCREEN.
  - GAS CONNECTION TO THE MECHANICAL UNIT SHALL BE ROUTED ON THE ROOF AS SHOWN AS 2.0 PSI. INSTALLATION COMPLETE WITH SHUTOFF VALVE, REGULATOR, UNION, AND 6" DIRT LEG.



CLIENT:  
NORTH MESA SCOOP, LLC  
C/O BRIAN FARRELL  
620 W LAWRENCE RD.  
PHOENIX, AZ 85013



08.08.2025  
**ISSUE FOR PERMIT**

**CULVER'S FROZEN CUSTARD**  
**MESA, AZ 85203**  
1830 E MCKELLIPS ROAD  
MESA, AZ 85203  
CLIENT: NORTH MESA SCOOP, C/O BRIAN FARRELL  
620 W LAWRENCE RD  
PHOENIX, AZ 85013

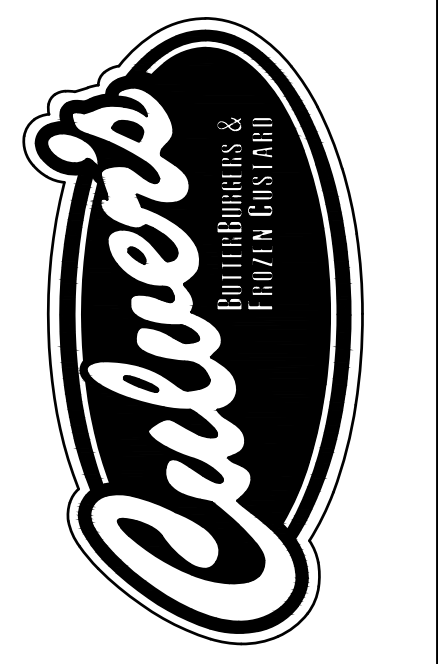

| DATE     | DESCRIPTION      |
|----------|------------------|
| 08/10/25 | ISSUE FOR PERMIT |

| DATE     | DESCRIPTION   |
|----------|---------------|
| 08/10/25 | CITY COMMENTS |

SHEET TITLE:  
**MEP ROOF PLAN**

SHEET NUMBER:  
**MEP1.0**

PROJECT NUMBER:  
**CFC24001**



| TEST AND BALANCE NOTES |  |
|------------------------|--|
| 1.                     | THE MECHANICAL CONTRACTOR SHALL SUBCONTRACT TO AN INDEPENDENT AIR TEST AND BALANCE CONTRACTOR FOR THE TESTING, ADJUSTING AND BALANCING OF ALL ENVIRONMENTAL SYSTEMS SHOWN OR SPECIFIED ON THE CONTRACT DOCUMENTS. THIS SHALL INCLUDE EQUIPMENT OPERATION IN COOLING, HEATING, AND DEHUMIDIFICATION OPERATIONAL MODES. THE WORK SHALL BE PERFORMED BY A FIRM CERTIFIED BY EITHER ASBC OR NEBB, AND A DIGITAL PDF DOCUMENT OF THE FINAL REPORT, SUBMITTED ON CERTIFYING AGENCY FORMS, SHALL BE EMAILED TO THE CLIENT'S CONSTRUCTION MANAGER FOR APPROVAL. THE REPORT SHALL BEAR THE CERTIFICATION SEAL OF THE TAB SUPERVISOR IN CHARGE. REPORTS SHALL CONTAIN ALL AIR SIDE BALANCING DATA, INSTRUMENTS USED AND THEIR LATEST CALIBRATION DATES, PERSON(S) PERFORMING THE WORK AND A WRITTEN GUARANTEE THAT ALL TAB WORK WAS PERFORMED IN ACCORDANCE WITH THE CERTIFYING AGENCY STANDARDS AND PROCEDURES. |
| 2.                     | THE TEST AND BALANCE REPORT SHALL INCLUDE OPERATIONAL DATA FOR EVERY COMPONENT OF THE COMPLETE MECHANICAL SYSTEM INCLUDING HVAC EQUIPMENT, HVAC AIR DEVICES, KITCHEN FANS, RESTROOM FANS, ETC. THIS DATA SHALL INCLUDE THE BALANCED OPERATING DATA FOR EQUIPMENT AS COMPARED TO THE DESIGN AIR BALANCE SCHEDULE ON THIS SHEET.   |
| 3.                     | FOR CLARIFICATION, THE ENGINEER OF RECORD WILL NOT BE ABLE TO REVIEW THE INSTALLED MECHANICAL SYSTEMS FOR POTENTIAL OPERATIONAL ISSUES OR INSTALLATION DEFICIENCIES WITHOUT THE FULL AND COMPLETE TEST AND BALANCE REPORT.   |

| HVAC SEQUENCE OF OPERATION |         |            |            |                      |                      |                        |
|----------------------------|---------|------------|------------|----------------------|----------------------|------------------------|
| MARK                       | SERVICE | FUNCTION   | START TIME | COOLING SETPOINT(°F) | HEATING SETPOINT(°F) | HUMIDITY SETPOINT(%RH) |
| RTU-1                      | FOH     | OCCUPIED   | 9:30 AM    | 72                   | 70                   | 55                     |
|                            |         | UNOCCUPIED | 12:00 AM   | 78                   | 65                   | 60                     |
|                            |         | OCCUPIED   | 7:00 AM    | 74                   | 68                   | 55                     |
| RTU-2                      | BOH     | OCCUPIED   | 7:00 AM    | 74                   | 68                   | 55                     |
|                            |         | UNOCCUPIED | 12:00 AM   | 78                   | 65                   | 60                     |

NOTES:

- UNIT FAN SHALL RUN CONTINUOUSLY DURING OCCUPIED HOURS, AND CYCLE ON DEMAND DURING UNOCCUPIED HOURS.
- UPON A CALL FOR COOLING:
  - COMPRESSORS TO CYCLE TO MAINTAIN THE SPACE SETTING, WITH THE GAS HEATER LOCKED OUT.
  - THERE SHALL BE A 2' DEAD BAND (ADJUSTABLE) BETWEEN THE 1ST AND 2ND STAGE OF COOLING.
  - THERE SHALL BE A 5 MINUTE (ADJUSTABLE) TIME DELAY BETWEEN THE 1ST AND 2ND STAGE OF COOLING.
- UPON A CALL FOR HEATING:
  - GAS FURNACE TO CYCLE TO MAINTAIN THE SPACE SETTING, WITH THE COMPRESSORS LOCKED OUT.
  - THERE SHALL BE A 2' DEAD BAND (ADJUSTABLE) BETWEEN THE 1ST AND 2ND STAGE OF HEATING.
  - THERE SHALL BE A 5 MINUTE (ADJUSTABLE) TIME DELAY BETWEEN THE 1ST AND 2ND STAGE OF HEATING.
- UPON A CALL FOR HUMIDITY CONTROL:
  - DURING OCCUPIED TIMES WHEN HUMIDISTAT INDICATES AN INCREASE IN HUMIDITY ABOVE THE SET POINT, THE HOT GAS REHEAT SYSTEM SHALL ACTIVATE TO REDUCE THE SPACE HUMIDITY TO BELOW SET POINT.
  - DURING UNOCCUPIED TIMES WHEN HUMIDISTAT INDICATES AN INCREASE IN HUMIDITY ABOVE THE SET POINT, THE FAN SHALL TURN ON AND THE HOT GAS REHEAT SYSTEM SHALL ACTIVATE TO REDUCE THE SPACE HUMIDITY TO BELOW SETPOINT.
- FIELD COORDINATE FINAL START TIME(S) WITH OWNER'S REPRESENTATIVE AND SITE SPECIFIC HOURS OF OPERATION PRIOR TO CALIBRATING FINAL SEQUENCE OF OPERATION FOR HVAC EQUIPMENT.

| AIR BALANCE SCHEDULE |              |      |     |                    |      |      |
|----------------------|--------------|------|-----|--------------------|------|------|
| MARK                 | DINING (CFM) |      |     | SERVICE AREA (CFM) |      |      |
|                      | S/A          | O/A  | E/A | S/A                | O/A  | E/A  |
| RTU-1                | 7000         | 1720 | -   | -                  | -    | -    |
| RTU-2                | -            | -    | -   | 8000               | 1960 | -    |
| KEF-1                | -            | -    | -   | -                  | -    | 1500 |
| KEF-2                | -            | -    | -   | -                  | -    | 1500 |
| MEF-1                | -            | -    | 75  | -                  | -    | -    |
| TEF-1                | -            | -    | 300 | -                  | -    | -    |
| TOTAL                | 7000         | 1720 | 375 | 8000               | 1960 | 3000 |

DINING PRESSURIZATION (O/A) - (E/A) = +1345 CFM  
 SERVICE PRESSURIZATION (O/A) - (E/A) = -1040 CFM  
 NET SPACE PRESSURIZATION (DINING + SERVICE) = +305 CFM

| O/A VENTILATION SCHEDULE |                         |            |     |                    |        |     |
|--------------------------|-------------------------|------------|-----|--------------------|--------|-----|
| AREA SERVED              | VENTILATION (OCCUPANCY) |            |     | VENTILATION (AREA) |        |     |
|                          | # OF PEOPLE             | CFM/PERSON | CFM | SQUARE FEET        | CFM/SF | CFM |
| DINING                   | 90                      | 7.5        | 675 | 1661               | 0.18   | 299 |
| RESTROOMS                | -                       | -          | -   | 229                | -      | -   |
| KITCHEN                  | 16                      | 7.5        | 120 | 1697               | 0.12   | 204 |
| SUBTOTALS                | -                       | -          | 795 | -                  | -      | 703 |
| TOTAL O/A REQUIRED       |                         |            |     | 1498 CFM           |        |     |

NOTES:

- CALCULATIONS ARE BASED ON 2018 IMC TABLE 403.1.1
- OUTDOOR AIR DEMAND IS: - 1498 CFM  
OUTDOOR AIR PROVIDED IS: + 3680 CFM  
OUTDOOR AIR DIFFERENCE IS: + 2182 CFM

| REFRIGERATION CALCULATIONS   |   |
|--|---|
| <b>WALK-IN COOLER:</b>   |   |
| 1. REFRIGERANT TYPE:   | R404A   |
| 2. COMPRESSOR HORSEPOWER:  | 1.5 HP  |
| 3. COMPRESSOR INSTALLATION LOCATION:   | ROOF-MOUNTED (REF 1/MEP1.0)                   |
| 4. MAXIMUM REFRIGERANT QUANTITY (T.1103):  | 31 LBS/1000 CU. FT.                           |
| 5. SYSTEM APPLICATION/VOLUME CALCULATIONS:   | 125.5 SQ.FT. X 8.25 FT. = 1036 CU. FT.        |
| COOLER DIMENSIONS:   | 1036 CU. FT. X (31 LBS/1000CU.FT.) = 32.1 LBS |
| 6. VAPOR LEAK DETECTION REQUIRED? (T.1104.2.2)   | NOT REQUIRED                                  |
| THEREFORE, INSTALLED COOLER REFRIGERATION SYSTEM SHALL HAVE NO MORE THAN 32.1 LBS OF REFRIGERANT. (SYSTEM CONTAINS 10.4 LBS OF REFRIGERANT @ 90% FULL) |   |
| <b>WALK-IN FREEZER:</b>  |   |
| 1. REFRIGERANT TYPE:   | R404A   |
| 2. COMPRESSOR HORSEPOWER:  | 3.5 HP  |
| 3. COMPRESSOR INSTALLATION LOCATION:   | ROOF-MOUNTED (REF 1/MEP1.0)                   |
| 4. MAXIMUM REFRIGERANT QUANTITY (T.1103):  | 31 LBS/1000 CU. FT.                           |
| 5. SYSTEM APPLICATION/VOLUME CALCULATIONS:   | 125.5 SQ.FT. X 8.25 FT. = 1036 CU. FT.        |
| COOLER DIMENSIONS:   | 1036 CU. FT. X (31 LBS/1000CU.FT.) = 32.1 LBS |
| 6. VAPOR LEAK DETECTION REQUIRED? (T.1104.2.2)   | NOT REQUIRED                                  |
| THEREFORE, INSTALLED COOLER REFRIGERATION SYSTEM SHALL HAVE NO MORE THAN 32.1 LBS OF REFRIGERANT. (SYSTEM CONTAINS 13.6 LBS OF REFRIGERANT @ 90% FULL) |   |

| AIR DEVICE SCHEDULE |           |         |                |              |                    |              |          |          |
|---------------------|-----------|---------|----------------|--------------|--------------------|--------------|----------|----------|
| MARK                | FACE SIZE | TYPE    | MOUNTING TYPE  | MAXIMUM N.C. | DIRECTION          | MANUFACTURER | MODEL    | NOTES    |
| CD                  | 24x24     | SUPPLY  | LAY-IN CEILING | 30           | 4-WAY              | RAYMON       | PROZ     | 1,3,10   |
| CR                  | 24x24     | RETURN  | LAY-IN CEILING | 30           | 1-WAY              | RAYMON       | FGEC-TB1 | 1,3,6,10 |
| CR2                 | 24x24     | RETURN  | LAY-IN CEILING | 30           | 1-WAY              | RAYMON       | RA-HVD   | 1,3,9,10 |
| GD                  | 12x12     | SUPPLY  | SURFACE        | 30           | 4-WAY              | RAYMON       | PRO2/OMF | 1,3,10   |
| GE                  | 12x12     | EXHAUST | SURFACE        | 30           | 1-WAY              | RAYMON       | RA-HVD   | 1,3,7,10 |
| GE2                 | 12x12     | EXHAUST | SURFACE        | 30           | 1-WAY              | RAYMON       | FGEC-TB1 | 1,3,6,10 |
| KD                  | 24x24     | SUPPLY  | LAY-IN CEILING | 30           | 4-WAY              | RAYMON       | PROZ     | 1,3,8,10 |
| KD2                 | 24x24     | SUPPLY  | LAY-IN CEILING | 30           | 4-WAY              | RAYMON       | PROZ     | 1,3,10   |
| KD3                 | 24x24     | SUPPLY  | LAY-IN CEILING | 30           | 4-WAY (PERFORATED) | RAYMON       | RPR      | 1,3,5,10 |
| KD4                 | 24x24     | SUPPLY  | LAY-IN CEILING | 30           | 3-WAY              | RAYMON       | PRO2/DAG | 1,3,10   |
| KD5                 | 24x24     | SUPPLY  | LAY-IN CEILING | 30           | 4-WAY              | RAYMON       | PROZ     | 2,3,10   |
| KR                  | 24x24     | RETURN  | LAY-IN CEILING | 30           | 1-WAY              | RAYMON       | RA-HVD   | 1,3,10   |

- NOTES:
- AIR DEVICES SHALL BE INSTALLED WITH FACTORY APPLIED WHITE FINISH. COORDINATE FINAL COLOR WITH ARCHITECTURAL DRAWINGS AND OWNER'S REPRESENTATIVE PRIOR TO INSTALLATION.
  - AIR DEVICES SHALL BE INSTALLED WITH FACTORY APPLIED FLAT BLACK FINISH. COORDINATE FINAL COLOR WITH ARCHITECTURAL DRAWINGS AND OWNER'S REPRESENTATIVE PRIOR TO INSTALLATION.
  - PROVIDE NECESSARY MOUNTING HARDWARE AND ACCESSORIES AS REQUIRED FOR INTENDED INSTALLATION.
  - AIR DEVICE SHALL BE INSTALLED WITH MANUFACTURER AVAILABLE MOLDED INSULATION BACKING. FIELD FABRICATED INSULATION BACKING IS NOT ALLOWED (UNLESS FIRST APPROVED BY THE OWNER'S CONSTRUCTION MANAGER).
  - AIR DEVICE NEAR THE EXHAUST HOOD CANOPY SHALL BE INSTALLED COMPLETE WITHOUT SUPPLY AIR FLOW PATTERN CONTROLS, TO PREVENT INTERFERENCE WITH EXHAUST CAPTURE AND CONTAINMENT.
  - REMOVE CORE DIFFUSERS FROM AIR DEVICE.
  - AIR DEVICE SHALL BE INSTALLED WITH ACCESSIBLE OPPOSED BLADE DAMPER FOR MANUAL VOLUME ADJUSTMENT.
  - AIR DEVICE SHALL BE PROVIDED WITH KXDA EXTENSION ROD WITH KNOB FOR MANUAL VOLUME ADJUSTMENT.
  - AIR DEVICE SHALL BE MOUNTED FOR LINE OF SIGHT TO GUESTS SUCH THAT OCCUPANT CANNOT SEE INTO DUCT.
  - CONTACT MARE WILSON (MUNDOCKER LLC) AT MARE@MUNDOCKER.COM OR (808) 845-9551 FOR PRICING AND VERIFY FINAL SELECTIONS FOR EQUIPMENT INFORMATION AND ORDERING. M.C. SHALL COORDINATE WITH OWNER AND G.C. TO SCHEDULE DELIVERY AND INSTALLATION.

| PACKAGED ROOFTOP UNIT SCHEDULE |                                  |              |          |   |
|--------------------------------|----------------------------------|--------------|----------|---|
| GENERAL                        | MARK                             | RTU-1        | RTU-2    | - |
|                                | SERVING                          | DINING       | KITCHEN  | - |
| MANUFACTURER                   | LENNOX                           | LENNOX       | -        | - |
| MODEL NO.                      | LG7210HEM                        | LG7240HEM    | -        | - |
| TYPE                           | GAS/ELEC                         | GAS/ELEC     | -        | - |
| OPERATING WEIGHT, LBS.         | 3059                             | 3091         | -        | - |
| LENGTH, WIDTH, HEIGHT          | 133"x92"x55"                     | 133"x92"x55" | -        | - |
| MINIMUM EER/SEER               | 12.0/16.0                        | 12.0/15.4    | -        | - |
| ELECTRICAL                     | VOLTS/PH/Hz                      | 208/3/60     | 208/3/60 | - |
|                                | MIN. CIRCUIT AMP. (MCA)          | 86.0         | 98.0     | - |
| MAX. OVERCURRENT PROT. (MOCP)  | 100.0                            | 110.0        | -        | - |
| SUPPLY FAN                     | SUPPLY AIR CFM                   | 7000         | 8000     | - |
|                                | OUTSIDE AIR CFM                  | 1720         | 1960     | - |
|                                | EXTERNAL STATIC PRESSURE IN W.G. | 0.75         | 0.75     | - |
|                                | FAN RPM                          | 938          | 1015     | - |
| MOTOR BHP                      | 4.35                             | 5.83         | -        | - |
| COOLING                        | NOMINAL SIZE TONS                | 17.5         | 20.0     | - |
|                                | TOTAL CAPACITY MBTUH             | 219.8        | 242.7    | - |
|                                | SENSIBLE CAPACITY MBTUH          | 158.3        | 182      | - |
|                                | ENTERING AIR DB/WB, DEG. F.      | 110          | 110      | - |
| ENTERING AIR DB/WB DEG. F.     | 80/67                            | 80/67        | -        | - |
| HEATING                        | TYPE OF HEAT                     | GAS          | GAS      | - |
|                                | HEATING INPUT MBTUH              | 360          | 360      | - |
|                                | HEATING OUTPUT MBTUH             | 292          | 292      | - |
|                                | OUTSIDE AIR DB, DEG. F.          | 34           | 34       | - |
| LEAVING AIR DB, DEG. F.        | 102.1                            | 97.4         | -        | - |

- NOTES:
- PROVIDE A FACTORY AVAILABLE 14" UN-INSULATED FLAT ROOF CURB THAT SHALL BE FIELD ASSEMBLED AND SHIMMED SUCH THAT THE TOP OF THE CURB SETS LEVEL. ROOF CURBS TO BE INSTALLED BY THE GENERAL CONTRACTOR, AND FIELD INSULATED BY THE MECHANICAL CONTRACTOR.
  - PROVIDE WITH LOW AMBIENT CONTROLS, COATED CONDENSER COILS, CONDENSER COIL HAIL GUARD, HINGED ACCESS PANELS, CRANK CASE HEATER, AND FROSTAT.
  - SENSORS AND LOW VOLTAGE CONTROL WIRING SHALL BE INSTALLED BY THE MECHANICAL CONTRACTOR.
  - PROVIDE WITH MANUFACTURER'S REMOTE TEMPERATURE/HUMIDITY SENSOR AND LENNOX CS7500 PROGRAMMABLE 24/7 THERMOSTAT CAPABLE OF AUTOMATIC COOLING/ HEATING CHANGEOVER.
  - PROVIDE FACTORY INSTALLED ENTHALPY CONTROLLED ECONOMIZER WITH MOTORIZED OUTSIDE AIR DAMPER.
  - PROVIDE FACTORY AVAILABLE RETURN AIR SMOKE DETECTOR(S), CAPABLE OF SHUTTING DOWN THE ROOFTOP UNIT UPON ACTIVATION.
  - PROVIDE FACTORY INSTALLED NON-FUSED ELECTRICAL DISCONNECT AND CONVENIENCE RECEPTACLE. RECEPTACLE SHALL BE FIELD WIRED BY THE E.C. AND POWERED SEPARATELY FROM THE UNIT.
  - PROVIDE SINGLE POINT ELECTRICAL POWER CONNECTION INCLUDING STARTERS AND CONTROLS.
  - UNIT SELECTIONS ARE BASED ON R-454B REFRIGERANT, AND HIGH EFFICIENCY OPERATION.
  - PROVIDE WITH HUMIDISTAT OPTION FOR HOT GAS REHEAT, CAPABLE OF AUTOMATIC OPERATION OF THE COOLING CYCLE (ONCE THE DEMAND FOR COOLING IS SATISFIED BY THE T-STAT) FOR SUPPLEMENTAL DEHUMIDIFICATION.
  - CONTACT LENNOX NATIONAL ACCOUNTS (LENNOX) AT LENNOX.NATIONALACCOUNTS@LENNOX.COM OR (800) 367-6285 FOR PRICING AND VERIFY FINAL SELECTIONS FOR EQUIPMENT INFORMATION AND ORDERING. M.C. SHALL COORDINATE WITH OWNER AND G.C. TO SCHEDULE DELIVERY AND INSTALLATION.

| FAN SCHEDULE |              |      |            |      |          |          |              |             |                     |        |         |
|--------------|--------------|------|------------|------|----------|----------|--------------|-------------|---------------------|--------|---------|
| MARK         | SERVICE      | CFM  | E.S.P. "WG | RPM  | MOTOR HP | VOLTS/PH | MANUFACTURER | MODEL       | TYPE                | WEIGHT | NOTES   |
| KEF-1        | GRIDDLE HOOD | 1500 | 1.80       | 1725 | 1.00     | 115/1    | ACCUREX      | XCUE-140-VG | ROOF UPBLAST FAN    | 92     | 1,3,5,6 |
| KEF-2        | FRYER HOOD   | 1500 | 1.00       | 1349 | 1.00     | 115/1    | ACCUREX      | XCUE-140-VG | ROOF UPBLAST FAN    | 92     | 1,3,5,6 |
| MEF-1        | MOP SINK     | 75   | 0.125      | 881  | 0.01     | 115/1    | ACCUREX      | SP-880      | CEILING CABINET FAN | 10     | 2,4,6   |
| TEF-1        | RESTROOMS    | 300  | 0.50       | 1466 | 0.10     | 115/1    | ACCUREX      | XRED-090-VG | ROOF DOWNBLAST FAN  | 31     | 2,4,6   |

NOTES:

- PROVIDE FAN INTERLOCK SWITCH VIA EXHAUST HOOD CONTROL SYSTEM BETWEEN KITCHEN HOOD EXHAUST AND MAU-1. COORDINATE REQUIRED WORK WITH THE ELECTRICAL CONTRACTOR.
- PROVIDE INDEPENDENT WEATHER PROOF DISCONNECT SWITCH IN SIGHT OF THE EQUIPMENT. COORDINATE THE REQUIRED WORK WITH THE ELECTRICAL CONTRACTOR.
- WEATHER PROOF DISCONNECT SWITCH AND INTERNAL WIRING SHALL BE FACTORY INSTALLED.
- PROVIDE GRAVITY BACKDRAP DAMPER.
- PROVIDE FACTORY AVAILABLE GREASE BOX AND BACKDRAP DAMPER.
- FURNISHED WITH KITCHEN HOOD PACKAGE, INSTALLED BY MECHANICAL CONTRACTOR.

| FLY FAN SCHEDULE |                   |        |      |           |          |              |            |                      |        |       |
|------------------|-------------------|--------|------|-----------|----------|--------------|------------|----------------------|--------|-------|
| MARK             | SERVICE           | LENGTH | CFM  | VOLTS/ PH | MCA/MOCP | MANUFACTURER | MODEL      | TYPE                 | WEIGHT | NOTES |
| FF-1             | REAR SERVICE DOOR | 48"    | 1442 | 115/1     | 5.1 / 20 | MARS         | STD248-1UA | WALL MNTD, DOWNBLAST | 70     | 1,2,3 |

NOTES:

- INSTALL COMPLETE WITH MANUFACTURER AVAILABLE MICROSWITCH FOR OPERATION, WALL MOUNTING PLATE, AND 3 WIRE CORD FOR POWER PLUG-IN.
- COORDINATE FINAL COLOR AND FINISH WITH OWNER'S REPRESENTATIVE PRIOR TO INSTALLATION.
- FLY FAN SHALL BE FURNISHED AND INSTALLED BY THE MECHANICAL CONTRACTOR.

| ELECTRIC HEATER SCHEDULE |              |                  |             |                      |              |          |       |
|--------------------------|--------------|------------------|-------------|----------------------|--------------|----------|-------|
| MARK                     | TYPE         | HEATING CAPACITY | MAXIMUM CFM | ELECTRICAL VOLT / PH | MANUFACTURER | MODEL    | NOTES |
| UH-1                     | UNIT/CABINET | 5.0 KW           | 350         | 208 / 1              | QMARK        | MUH05-81 | 1,2   |

NOTES: (NOT ALL MAY APPLY)

- COORDINATE POWER AND DISCONNECT REQUIREMENTS WITH THE ELECTRICAL CONTRACTOR.
- INSTALL COMPLETE WITH MANUFACTURER AVAILABLE SUSPENSION MOUNTING BRACKET.

| MECHANICAL LEGEND |       |                                       |
|-------------------|-------|---------------------------------------|
| SYMBOL            | ABBR. | DESCRIPTION                           |
|                   | CD    | CEILING DIFFUSER - SUPPLY             |
|                   | CD    | CEILING DIFFUSER BELOW DUCT - SUPPLY  |
|                   | SAD   | RISER - SUPPLY AIR DUCT               |
|                   | SAD   | DROP - SUPPLY AIR DUCT                |
|                   | CR    | CEILING REGISTER - RETURN             |
|                   | CR    | CEILING REGISTER BELOW DUCT - RETURN  |
|                   | RAD   | RISER - RETURN AIR DUCT               |
|                   | RAD   | DROP - RETURN AIR DUCT                |
|                   | CE    | CEILING REGISTER - EXHAUST            |
|                   | CE    | CEILING REGISTER BELOW DUCT - EXHAUST |
|                   | EAD   | RISER - EXHAUST AIR DUCT              |
|                   | (L)   | LINED DUCTWORK                        |
|                   | VD    | MANUAL VOLUME DAMPER                  |
|                   | FC    | FLEXIBLE CONNECTION                   |
|                   |       | NEW DUCT                              |
|                   |       | AIR DEVICE DESIGNATION                |
|                   | TSTAT | PROGRAMMABLE THERMOSTAT               |
|                   | SENS  | REMOTE TEMPERATURE SENSOR             |
|                   | SD    | SMOKE DETECTOR                        |
|                   | POC   | POINT OF CONNECTION                   |
|                   | S/A   | SUPPLY AIR                            |
|                   | R/A   | RETURN AIR                            |
|                   | O/A   | OUTSIDE AIR                           |
|                   | E/A   | EXHAUST AIR                           |
|                   | S.P.  | STATIC PRESSURE                       |
|                   | FOH   | FRONT OF HOUSE                        |
|                   | BOH   | BACK OF HOUSE                         |

ENSURE DIRECT DRIVE

| GENERAL NOTES |  |
|---------------|--|
| 1.            | FOR THE PURPOSE OF CLEARNESS AND LEGIBILITY, THE DRAWINGS ARE ESSENTIALLY DIAGRAMMATIC AND ALTHOUGH SIZES AND LOCATIONS OF EQUIPMENT ARE DRAWN TO SCALE WHEREVER POSSIBLE, THE CONTRACTOR SHALL MAKE USE OF ALL DATA THROUGHOUT THE CONTRACT DOCUMENTS AND VERIFY THIS INFORMATION PRIOR TO ORDERING, FABRICATING OR INSTALLING ANY MATERIALS.   |
| 2.            | THE MECHANICAL CONTRACTOR SHALL PROVIDE COMPLETE INFORMATION AND COOPERATE WITH THE OTHER CONTRACTORS AND TRADES AS REQUIRED FOR THE COMPLETION AND COORDINATION OF THE COMPLETE PROJECT.  |
| 3.            | THE MECHANICAL CONTRACTOR SHALL BE RESPONSIBLE FOR ADMINISTERING ALL WARRANTIES ON EQUIPMENT WHICH THEY FURNISH AND INSTALL. PROVIDE WRITTEN WARRANTY TO REPLACE ALL FAULTY MATERIALS AND/OR LABOR, AT NO COST TO TENANT, FOR A PERIOD OF ONE YEAR FROM DATE OF ACCEPTANCE BY THE OWNER. WARRANTIES SHALL BEGIN ON THE DATE OF SUBSTANTIAL COMPLETION.   |
| 4.            | THE MECHANICAL CONTRACTOR SHALL COORDINATE WITH THE GENERAL CONTRACTOR AND OTHER TRADES ALL REQUIRED OPENINGS AND PENETRATIONS. ALL REQUIRED OPENINGS IN FOUNDATIONS, FLOORS, WALLS AND ROOF SHALL BE CONSTRUCTED INTO THE STRUCTURE WITH THE USE OF SLEEVES, CURBS, ETC. CUTTING AND PATCHING SHALL BE HELD TO A MINIMUM.   |
| 5.            | THE MECHANICAL CONTRACTOR SHALL COORDINATE ALL DUCT AND DIFFUSER LOCATIONS WITH SPRINKLER PIPING, SPRINKLER HEADS AND LIGHT FIXTURES AS REQUIRED FOR A COMPLETE INSTALLATION.  |
| 6.            | PROVIDE VIBRATION ISOLATION DEVICES AND FLEXIBLE DUCT/ PIPING CONNECTIONS TO ALL MOVING MACHINERY NOT INTERNALLY ISOLATED.   |
| 7.            | ALL ITEMS PROJECTING THROUGH THE ROOF SHALL BE FLASHED THROUGH CURBS OR PIPE SEALS A MINIMUM OF 12" ABOVE THE ROOF. THE PIPE CURBS AND SEALS SHALL BE INSTALLED BY THE ROOFING CONTRACTORS AND ENSURE THAT AMPLE BOOT OPENINGS ARE PROVIDED TO ACCOMMODATE ANY ELECTRICAL CONDUIT PENETRATIONS REQUIRED FOR POWER.   |
| 8.            | ALL OUTDOOR AIR INTAKES BY MECHANICAL EQUIPMENT SHALL HAVE A MINIMUM 10'-0" HORIZONTAL CLEARANCE FROM THE DISCHARGE OF ANY EXHAUST FAN, COMBUSTION EXHAUST OR FLUING VENT.   |
| 9.            | HVAC UNITS SHALL BE SET TO RUN IN "FAN CONTINUOUS" MODE DURING OCCUPIED HOURS. DURING NIGHT SET-BACK HOURS, THE HVAC UNITS SHALL RUN IN "FAN AUTO" MODE.   |
| 10.           | MECHANICAL CONTRACTOR SHALL FURNISH AND INSTALL 4" HIGH BLACK OVER WHITE LAMINATE NAMEPLATE WITH 2" LETTERS VISIBLE ADJACENT TO DISCONNECT SWITCH FOR HVAC UNITS AND FANS.   |
| 11.           | ANY FLEXIBLE DUCTS SHALL BE INSTALLED IN CONCEALED SPACES ONLY. THE MAXIMUM ALLOWABLE LENGTH OF FLEXIBLE DUCT SHALL BE 5'-0". ALL FLEXIBLE DUCTS SHALL BE CONNECTED TO BRANCH RUNS AND FITTINGS WITH A FRUIT-TYPE BAND, AND SHALL NOT BE ATTACHED DIRECTLY TO THE AIR DEVICE COLLAR.   |
| 12.           | SUPPLY, RETURN, RESTROOM EXHAUST DUCT CONSTRUCTION SHALL BE GALVANIZED STEEL (UNO.) GAUGES, SWAY BRACING AND SUSPENSION SHALL CONFORM TO SUCH A COMPLETE INSTALLATION.   |
| 13.           | ALL HVAC SUPPLY AND RETURN EXPOSED RIGID DUCTWORK SHALL BE INTERNALLY LINED AND FINISHED WITH MINIMUM R-8, 1-1/2" INSULATION WITH VAPOR BARRIER PER THE 2018 INTERNATIONAL MECHANICAL CODE WITH LOCAL AMENDMENTS. INSULATION SHALL HAVE MAXIMUM RATINGS OF 25 FLAME SPREAD, 50 SMOKE DEVELOPED. REFER TO ARCHITECTURAL DRAWINGS FOR DUCT PAINT OR COLOR SPECIFICATION.   |
| 14.           | ALL HVAC SUPPLY AND RETURN CONCEALED RIGID DUCTWORK TO BE EXTERNALLY WRAPPED AND SECURED WITH MINIMUM R-8, 2" INSULATION WITH VAPOR BARRIER PER THE 2018 INTERNATIONAL MECHANICAL CODE WITH LOCAL AMENDMENTS. INSULATION SHALL HAVE MAXIMUM RATINGS OF 25 FLAME SPREAD, 50 SMOKE DEVELOPED.  |
| 15.           | ALL PENETRATIONS IN FIRE RATED WALL ASSEMBLIES SHALL BE SEALED WITH UL LISTED FIRE STOPPING MATERIAL.  |
| 16.           | ALL DUCT DIMENSIONS SHOWN ON DRAWINGS ARE CLEAR INSIDE DIMENSIONS.   |
| 17.           | ALL RECTANGULAR, ROUND, AND FLEXIBLE DUCTWORK SHALL BE SIZED AS SHOWN ON THESE DRAWINGS; AND SHALL BE FABRICATED AND INSTALLED ACCORDING TO THE MOST RECENTLY PUBLISHED SMARNA STANDARDS. ALL JOINTS, SEAMS, AND CONNECTIONS MUST BE SECURELY FASTENED & SEALED BY APPROVED METHODS.   |
| 18.           | THERMOSTAT(S) SHALL BE LOCATED AT 48" A.F.F. EXACT LOCATIONS SHALL BE FIELD COORDINATED TO AVOID INTERFERENCE WITH WALL-MOUNTED WORK OR PROXIMITY TO HEAT PRODUCING EQUIPMENT.   |
| 19.           | PER THE 2018 INTERNATIONAL MECHANICAL CODE WITH CITY AMENDMENTS WHEN REQUIRED, EACH SINGLE SYSTEM PROVIDING HEATING OR COOLING AIR IN EXCESS OF 2000 CUBIC FEET PER MINUTE SHALL BE EQUIPPED WITH AN AUTOMATIC SHUTOFF. AUTOMATIC SHUTOFF SHALL BE ACCOMPLISHED BY INTERRUPTING THE POWER SOURCE OF THE AIR MOVING EQUIPMENT DEVICES WHICH WILL DETECT PRODUCTS OF COMBUSTION OTHER THAN HEAT, AND WHICH COMPLY WITH THE BUILDING CODE, SHALL BE LABELED BY AN APPROVED AGENCY FOR AIR DUCT INSTALLATION AND SHALL BE INSTALLED IN ACCORDANCE WITH THE MANUFACTURER'S INSTRUCTIONS. SUCH DEVICES SHALL BE COMPATIBLE WITH THE OPERATING VELOCITIES, PRESSURES, TEMPERATURES AND HUMIDITIES OF THE SYSTEM WHERE FIRE DETECTION OR ALARM SYSTEMS ARE PROVIDED FOR THE BUILDING, SMOKE DETECTORS SHALL BE SUPERVISED BY SUCH SYSTEMS. |
| 20.           | THE MECHANICAL CONTRACTOR SHALL BE RESPONSIBLE FOR REPLACING THE AIR FILTERS AT THE AIR HANDLING UNITS WITH PLEATED MERV 13 THROW AWAY TYPE AIR FILTERS AT THE COMPLETION OF CONSTRUCTION AND PRIOR TO AIR BALANCE AND STORE TURNOVER.   |
| 21.           | MECHANICAL CONTRACTOR SHALL BE ON SITE AND PRESENT AT THE DATE OF STORE TURNOVER.  |
| 22.           | ALL TYPE-1 GREASE EXHAUST DUCTS SHALL BE NFPA 9 APPROVED 16 GA. WELDED BLACK IRON, EXTERNALLY WELDED WITH LIQUID TIGHT JOINTS, SEAMS, AND SMOOTH RADIUS ELBOWS AND TRANSITIONS.  |
| 23.           | ALL TYPE-1 GREASE DUCTS SHALL BE DOUBLE WRAPPED WITH UL LISTED FIRE WRAP SIMILAR TO 3M FIRE BARRIER DUCT WRAP 20A IN ACCORDANCE WITH THE MANUFACTURER'S INSTALLATION INSTRUCTIONS. EACH GREASE DUCT RISER SHALL BE WRAPPED TO THE FULL EXTENT POSSIBLE FROM THE HOOD COLLAR CONNECTION UP TO THE TERMINATION AT THE EXHAUST FAN INLET. ALL GREASE EXHAUST FAN ROOF CURBS SHALL BE VENTED PER NFPA 96. PROVIDE REQUIRED ACCESS FOR SERVICING AND CLEANING, AND VERIFY THE HINGED CURB OPENING OPERATES PROPERLY.  |
| 24.           | PITCH ALL HORIZONTAL GREASE AND CONDENSATE DUCTWORK UNIFORMLY BACK TOWARDS THE RESPECTIVE HOOD OR APPLIANCE AT A MINIMUM 1/4" PER FOOT (NOT TO EXCEED 50'-0").   |
| 25.           | ALL GREASE EXHAUST FAN ROOF CURBS SHALL BE VENTED PER NFPA 96. PROVIDE REQUIRED ACCESS FOR SERVICING AND CLEANING, AND VERIFY THE HINGED CURB OPENING OPERATES PROPERLY.   |
| 26.           | ROOF CURBS FOR EXHAUST FANS AND THE MAKEUP AIR UNIT SHALL BE FACTORY FABRICATED AND FURNISHED WITH THE HOOD PACKAGE. VERIFY REQUIREMENTS FOR THE ROOF CURBS WITH THE EQUIPMENT SUP   |

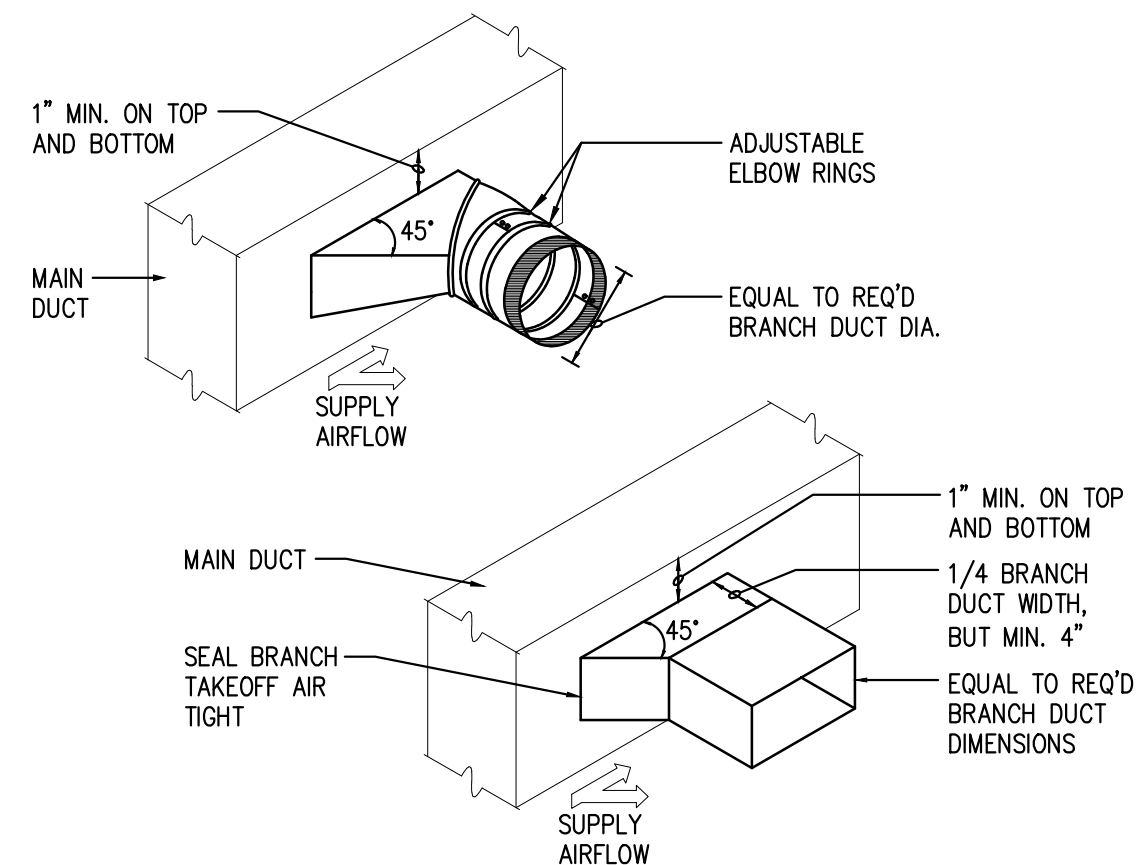

BRANCH TAKE-OFF FITTING DETAIL  
SCALE: NONE 1

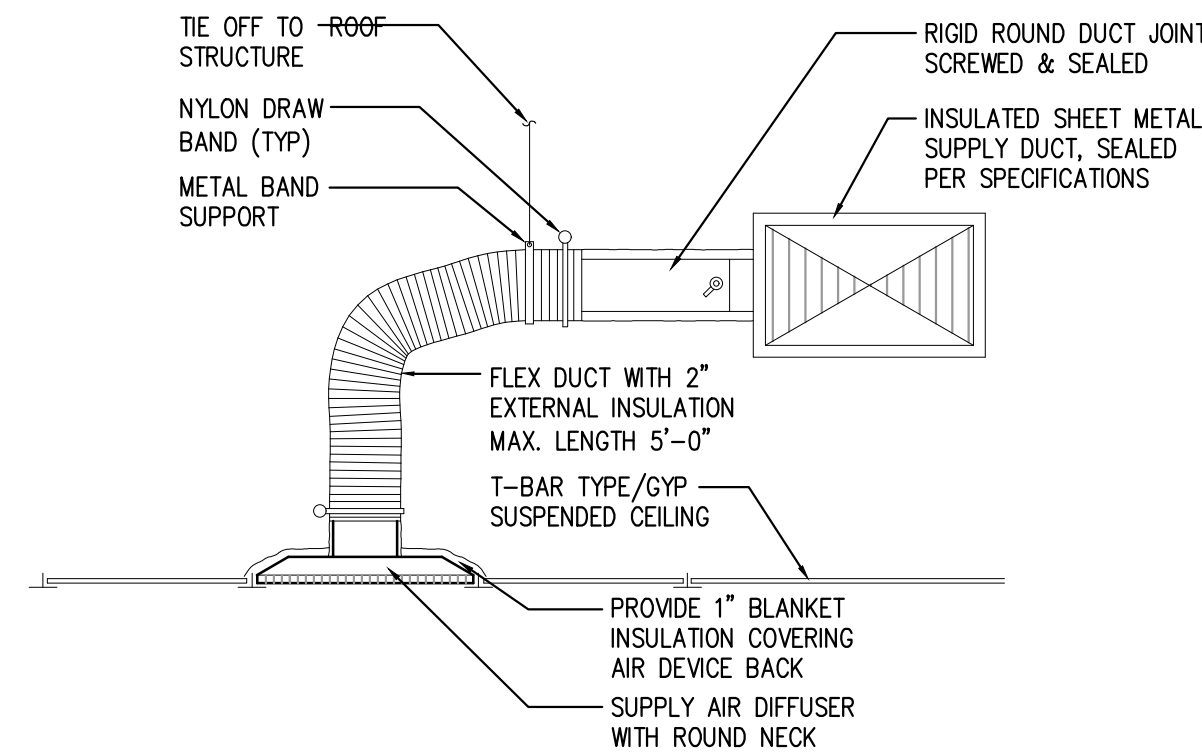

CEILING MOUNTED SUPPLY AIR DIFFUSER DETAIL  
SCALE: NONE 2

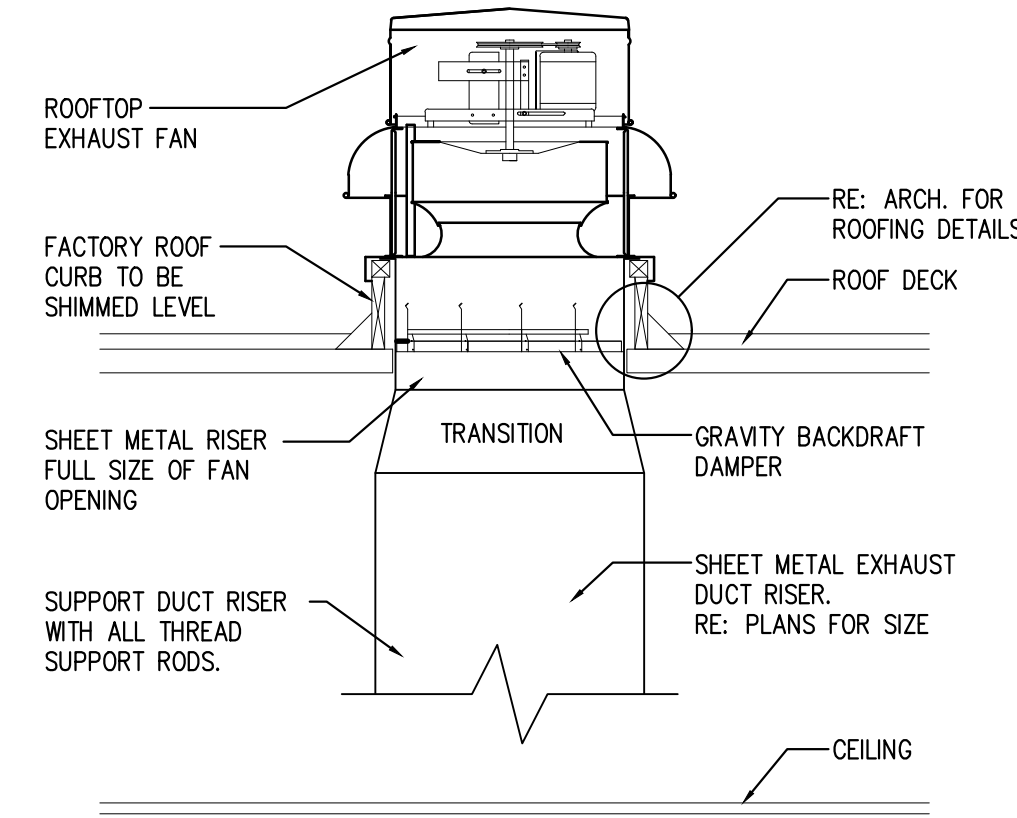

RESTROOM DOWNBLAST EXHAUST FAN DETAIL  
SCALE: NONE 3

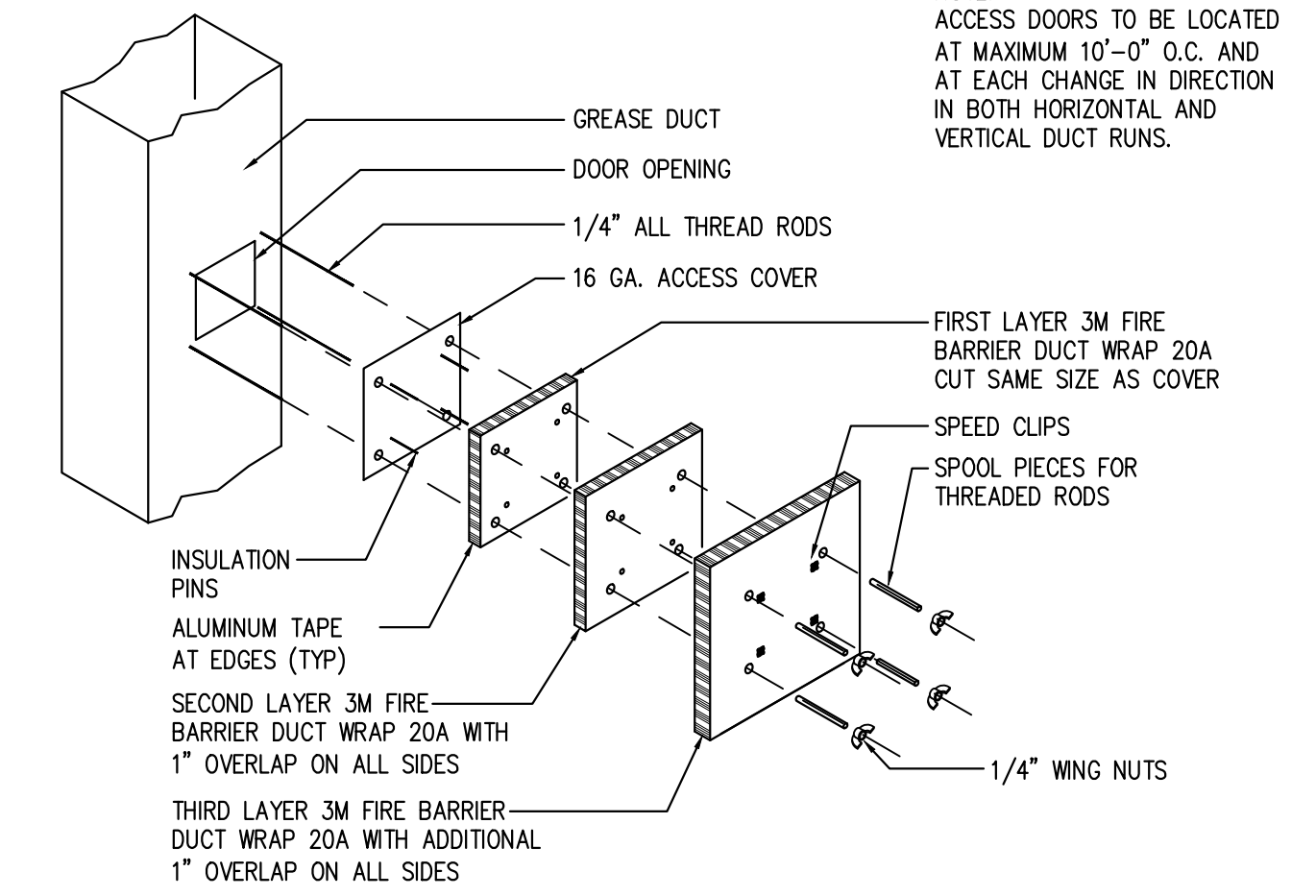

UL LISTED GREASE EXHAUST DUCT ACCESS DOOR DETAIL  
SCALE: NONE 4

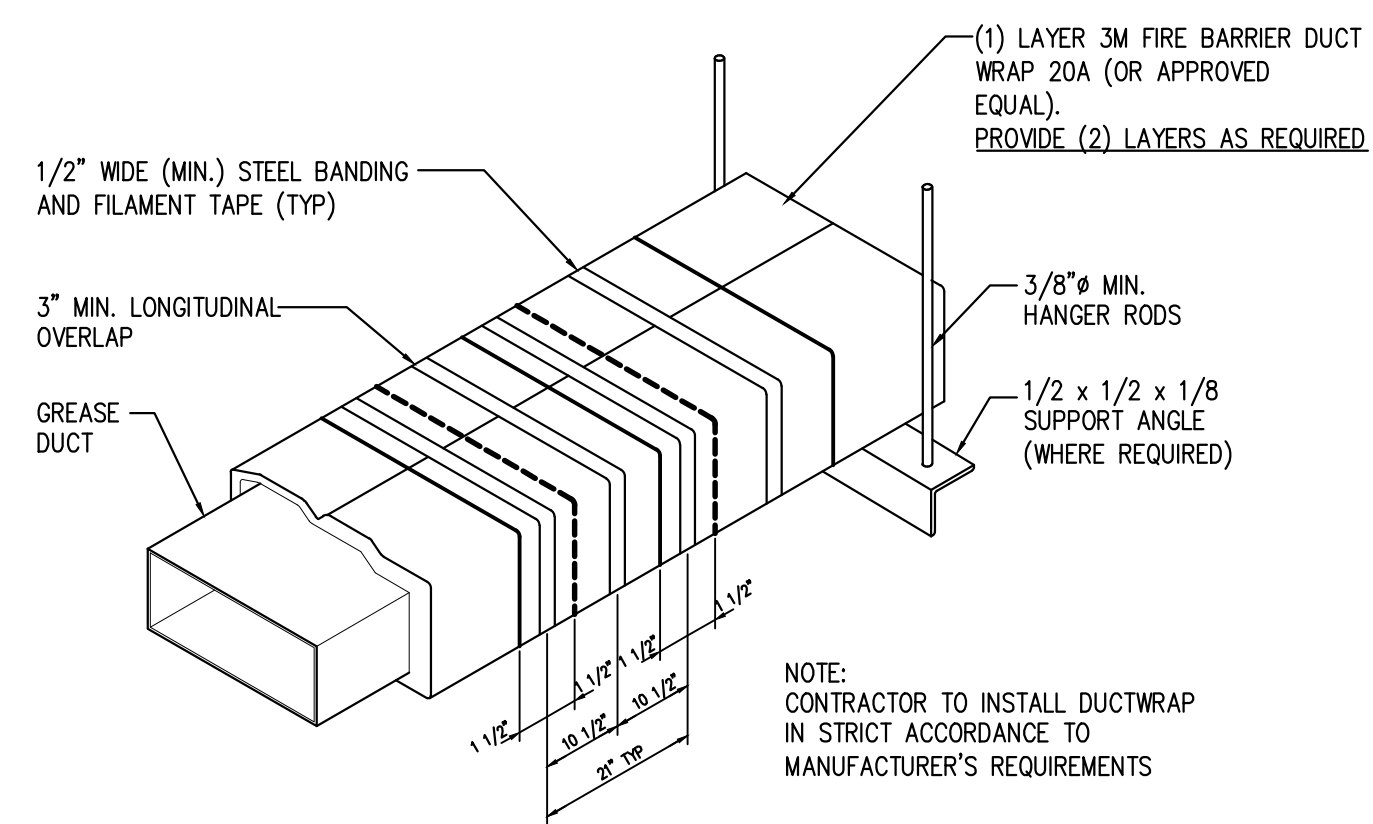

UL LISTED GREASE EXHAUST DUCT WRAP DETAIL  
SCALE: NONE 5

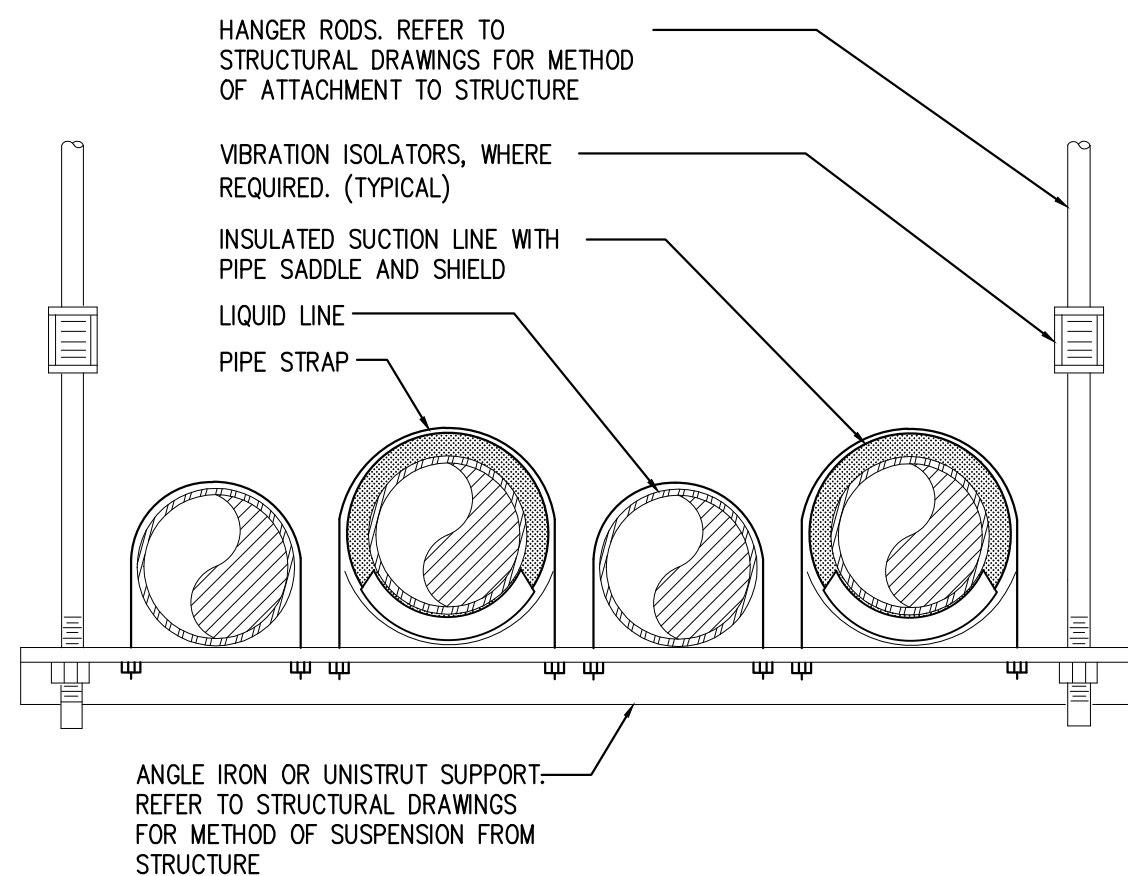

HORIZONTAL REFRIGERANT PIPE SUPPORT DETAIL  
SCALE: NONE 6

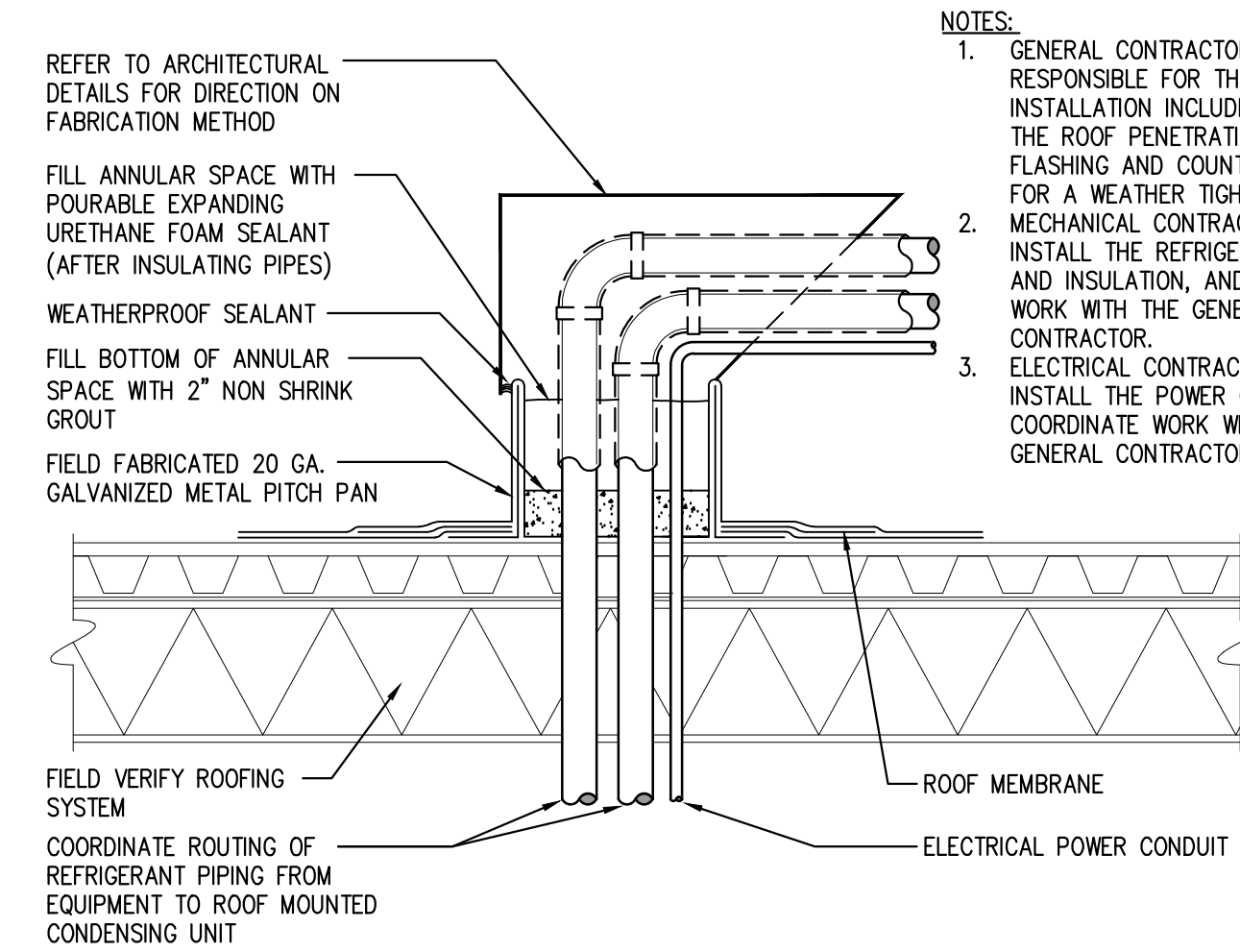

PIPING AND CONDUIT ROOF PENETRATION DETAIL  
SCALE: NONE 7

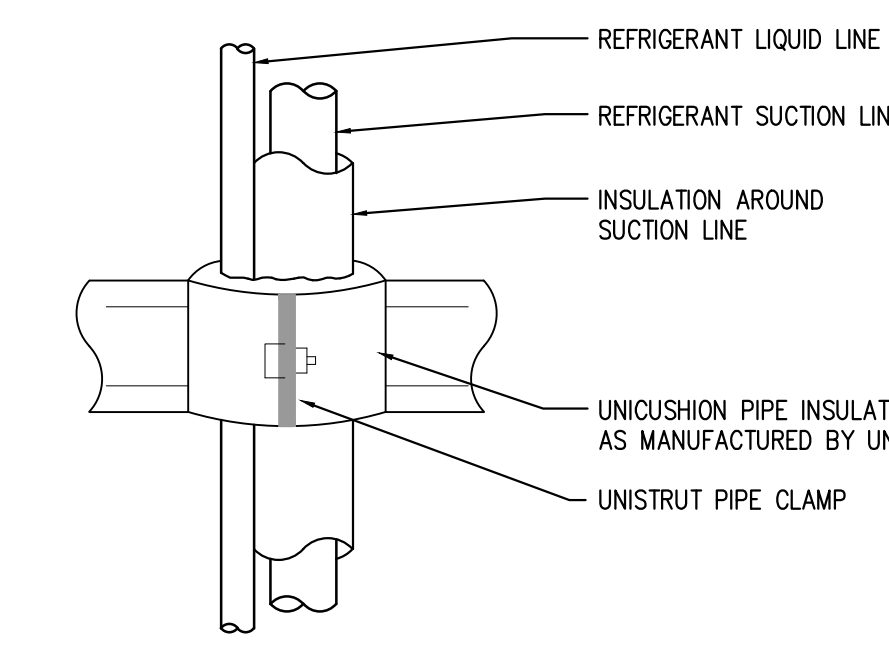

VERTICAL REFRIGERANT PIPE SUPPORT DETAIL  
SCALE: NONE 8

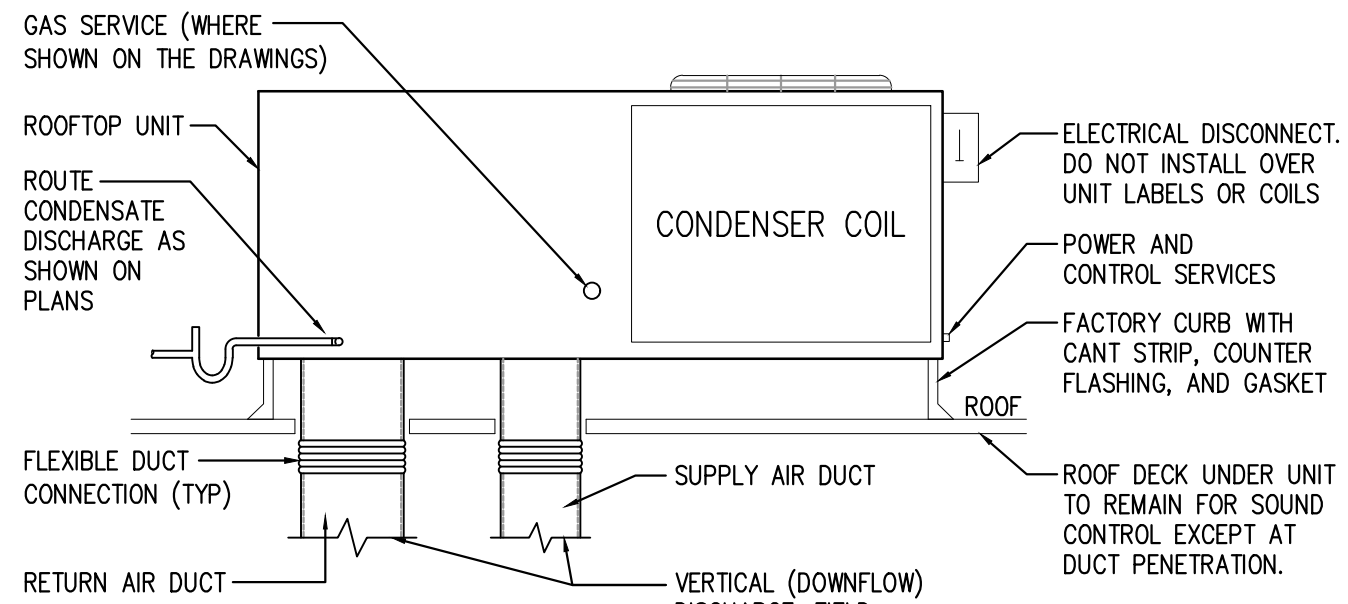

PACKAGED ROOFTOP UNIT DETAIL  
SCALE: NONE 9

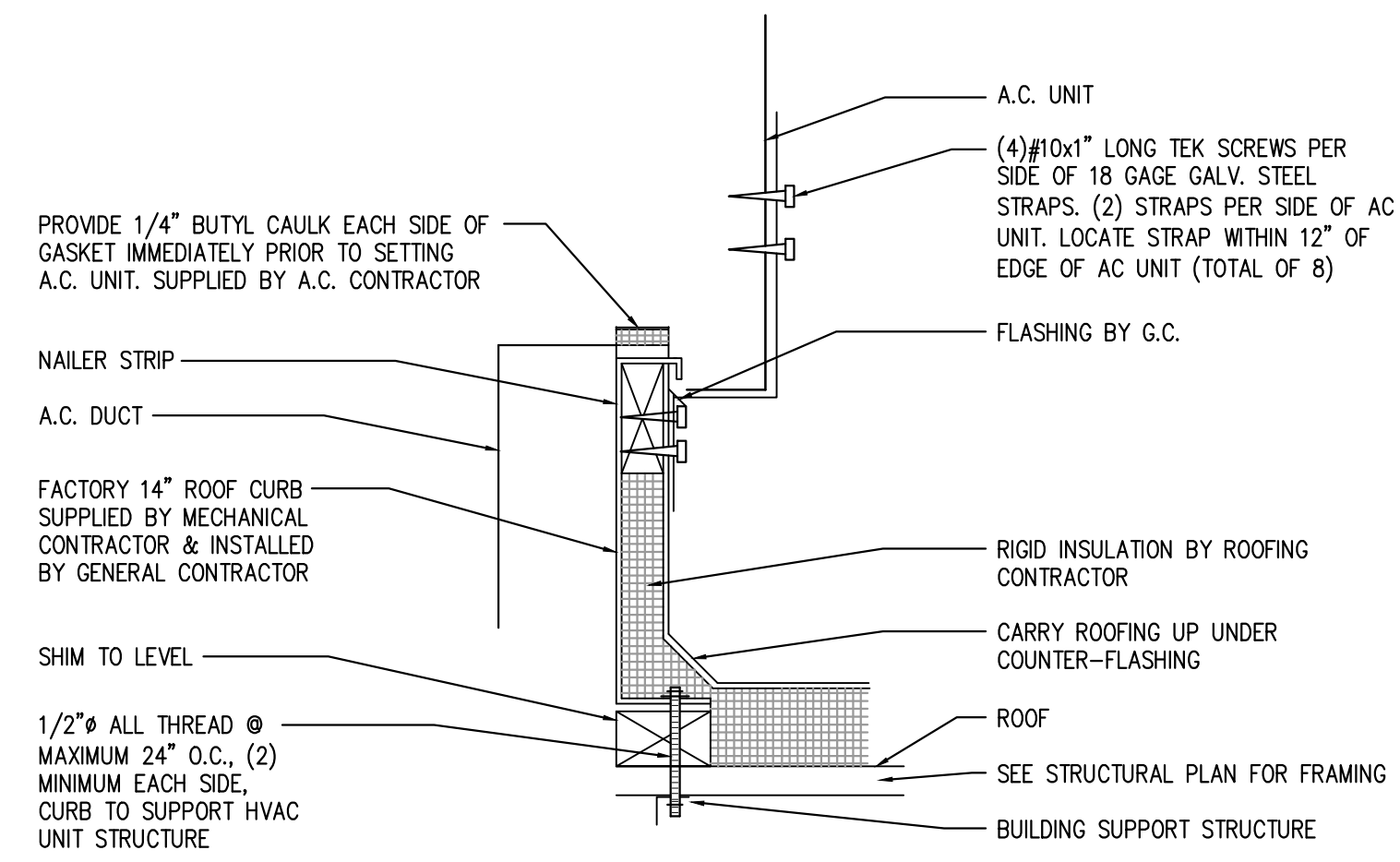

PACKAGED ROOFTOP UNIT CURB BASE DETAIL  
SCALE: NONE 10

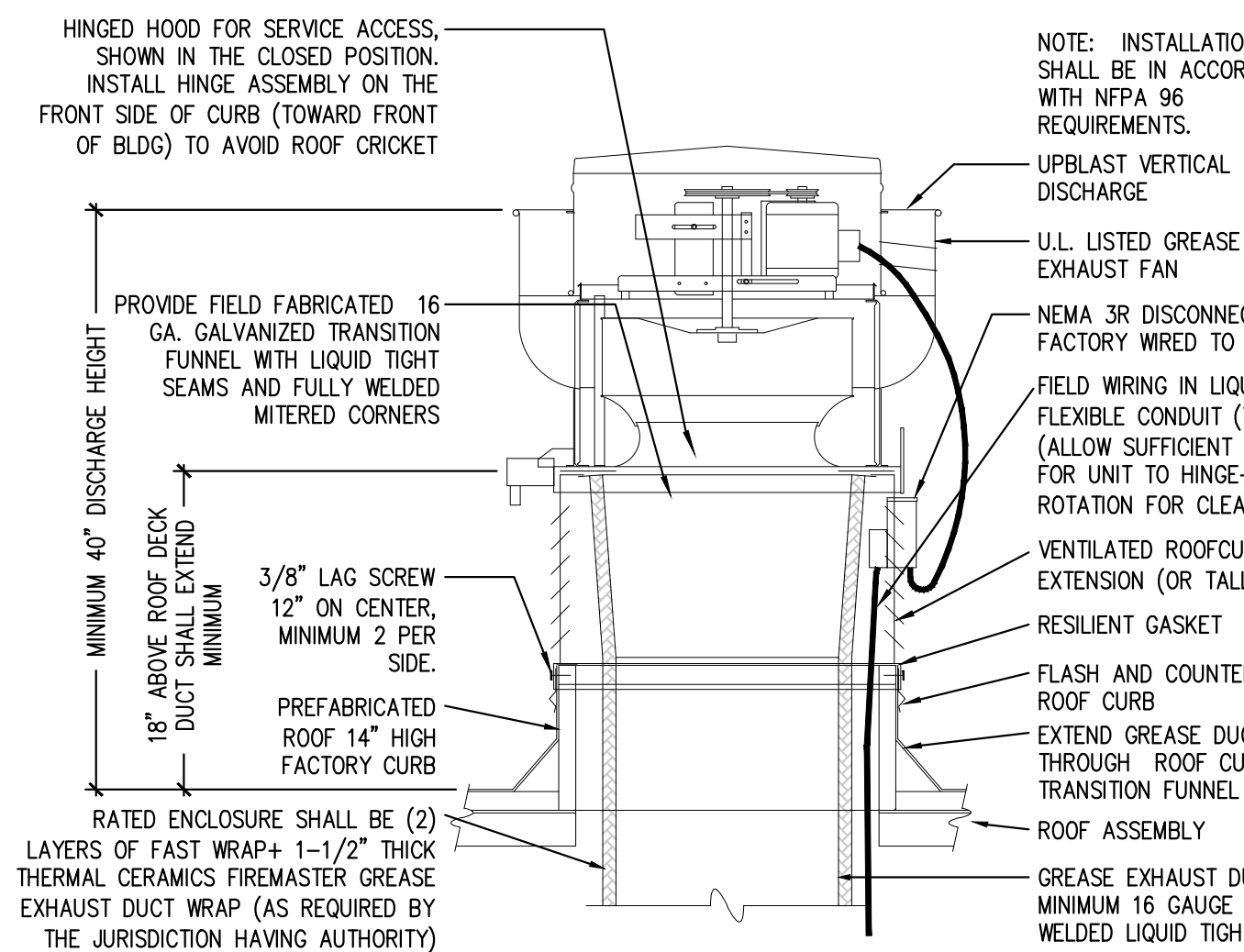

KITCHEN UPBLAST GREASE EXHAUST FAN DETAIL  
SCALE: NONE 11

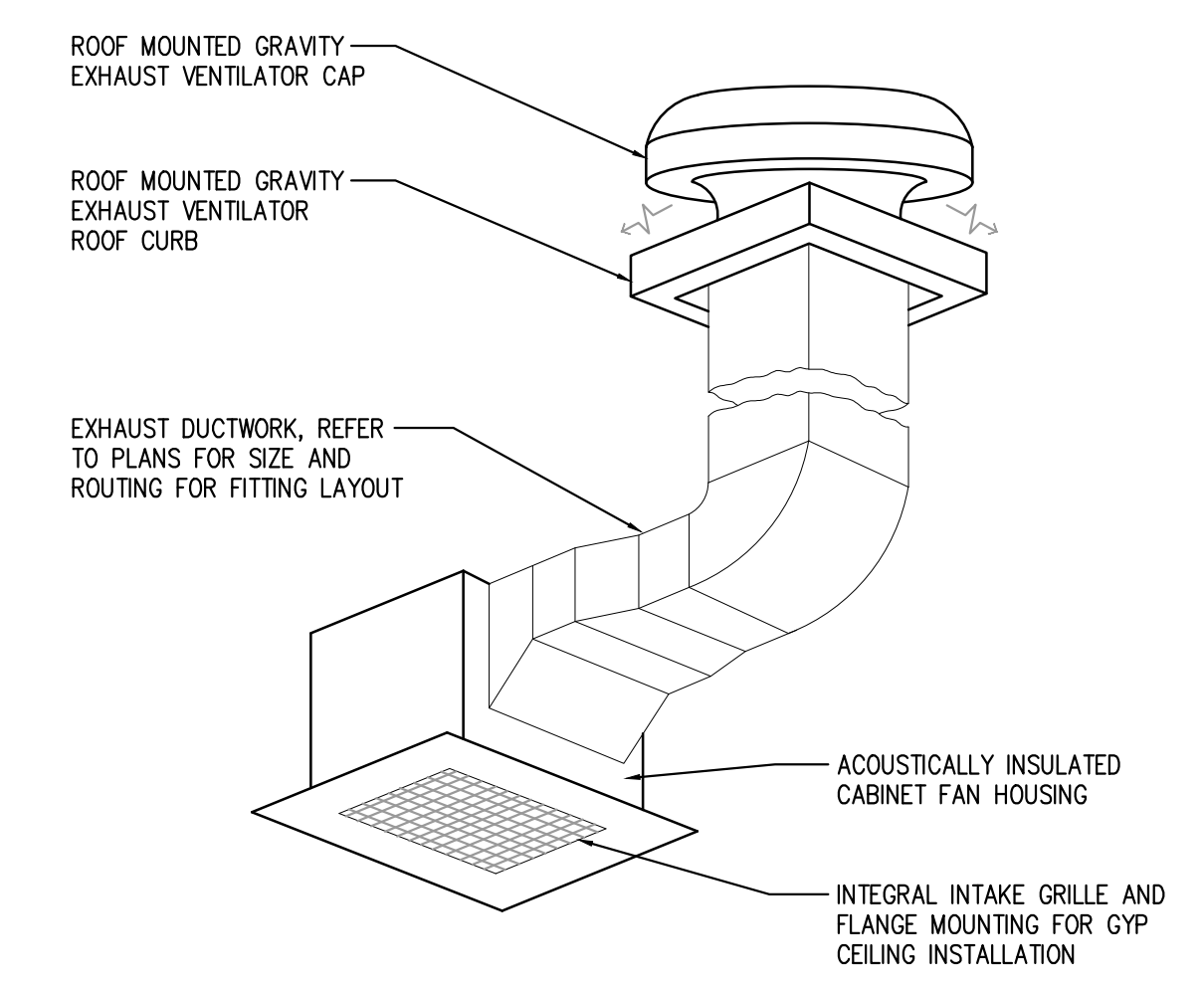

CEILING MOUNTED CABINET FAN DETAIL  
SCALE: NONE 12

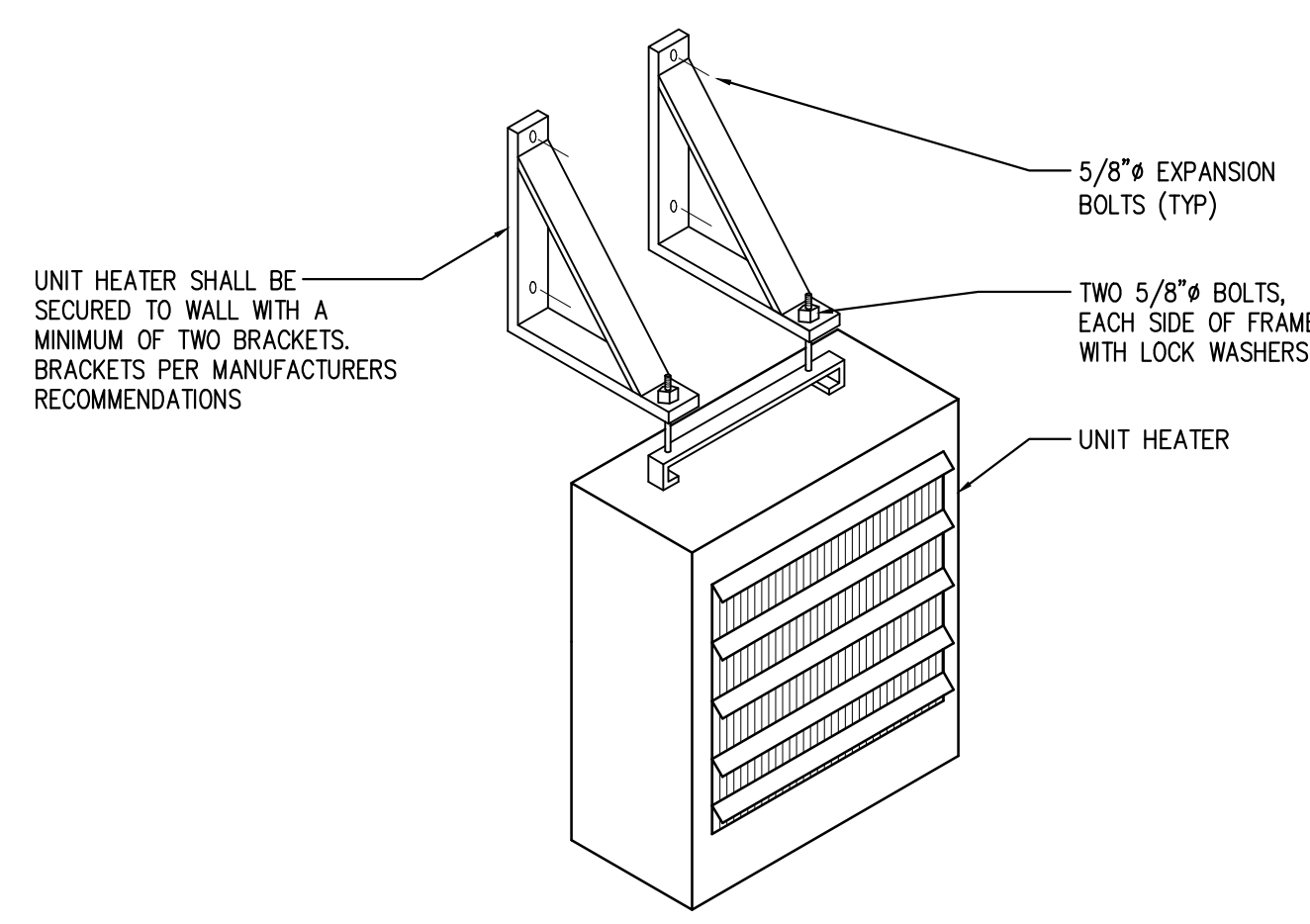

UNIT HEATER DETAIL  
SCALE: NONE 13

NOT USED  
SCALE: NONE 14

NOT USED  
SCALE: NONE 15

NOT USED  
SCALE: NONE 16

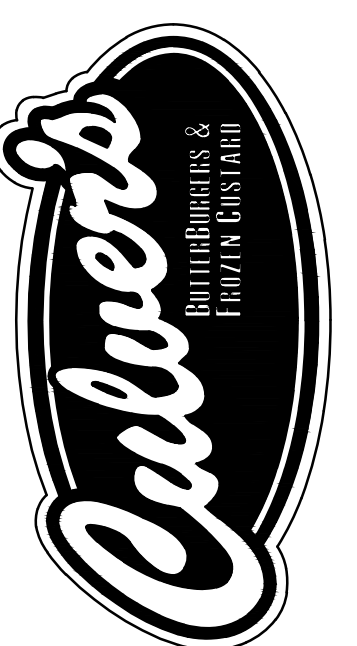

| DATE       | DESCRIPTION      |
|------------|------------------|
| 07/11/2025 | ISSUE FOR PERMIT |

| DATE | DESCRIPTION |
|------|-------------|
|------|-------------|

MECHANICAL  
DETAILS

SHEET NUMBER

M3.0

PROJECT NUMBER  
CFC24001

PMT25-12454

| HOOD NO. | MARK         | MODEL     | HOOD DIMENSIONS (IN.) |                 |                   | HOOD CONSTR.            | COOKING LOAD / DUTY RATING | TOTAL CFM | EXHAUST COLLAR(S) |        |      |      | SUPPLY |         | HANGING WEIGHT LBS. | SECTION LOCATION |        |
|----------|--------------|-----------|-----------------------|-----------------|-------------------|-------------------------|----------------------------|-----------|-------------------|--------|------|------|--------|---------|---------------------|------------------|--------|
|          |              |           | LENGTH                | WIDTH           | HEIGHT            |                         |                            |           | WIDTH             | LENGTH | DIA. | CFM  | S.P.   | MUA CFM |                     |                  | AC CFM |
| 1        | GRIDDLE HOOD | XXEP-64-S | 64                    | TOP 23<br>BOT 8 | FRT 12<br>BACK 36 | 430 SS<br>WHERE EXPOSED | MEDIUM                     | 1500      | 12                | 12     |      | 1500 | 0.924  |         |                     | 137              | SINGLE |

| HOOD NO. | MARK         | LIGHTING DETAILS |                  |     | GREASE FILTRATION DETAILS |   |          | UTILITY CABINET(S) |            |          |             |          |
|----------|--------------|------------------|------------------|-----|---------------------------|---|----------|--------------------|------------|----------|-------------|----------|
|          |              | FIXTURE TYPE     | BULB / LAMP INFO | QTY | FOOT CANDLES              | TYPE / MODEL  | MATERIAL | QTY                | SIZE (IN.) | LOCATION | FIRE SYSTEM | CONTROLS |
| 1        | GRIDDLE HOOD |                  |                  |     |                           | X-TRACTOR (SPARK ARRESTOR INCL.)<br>STAINLESS STEEL | 4        | 18                 | 16         |          |             |          |

**HOOD OPTIONS**

UL 710 LISTED W/OUT EXHAUST FIRE DAMPER - UL #R25625  
 BACK NON-INTEGRAL AIR SPACE - 3 IN WIDE  
 26 IN HIGH CEILING ENCLOSURES - FRONT LEFT RIGHT - FIELD INSTALLED  
 FACTORY MOUNTED EXHAUST COLLAR(S)  
 PERFORMANCE ENHANCING LIP (PEL) TECHNOLOGY  
 STANDING SEAM CONSTRUCTION FOR SUPERIOR STRENGTH

**SPECIAL DESIGN REQUESTS**

SDR #K2400336 - CULVERS MAGIKITCH'N OR VULCAN FLUE BYPASS, AMEREX FIRE, GX  
 SDR #K2400436 - CULVERS AMEREX SHARED FIRE SYSTEM PROCESS

| MARK INFORMATION  |     |             |            | FAN INFORMATION |                      |                            |                 | SOUND INFORMATION        |      |                   |           | MOTOR INFORMATION |                         |            |              |                      |                 |                      |           |         |       |       |           |          |
|-------------------|-----|-------------|------------|-----------------|----------------------|----------------------------|-----------------|--------------------------|------|-------------------|-----------|-------------------|-------------------------|------------|--------------|----------------------|-----------------|----------------------|-----------|---------|-------|-------|-----------|----------|
| MARK              | QTY | MODEL       | DRIVE TYPE | VOLUME (CFM)    | EXTERNAL SP (IN. WG) | TOTAL EXTERNAL SP (IN. WG) | FAN SPEED (RPM) | OUTLET VELOCITY (FT/MIN) | FEI  | TOTAL WEIGHT (LB) | INLET dBA | INLET SONES       | INLET SONES (SPHERICAL) | OUTLET dBA | OUTLET SONES | OPERATING POWER (HP) | MOTOR SIZE (HP) | FEP INPUT POWER (KW) | ENCLOSURE | VOLTAGE | CYCLE | PHASE | EC MOTOR  | NEC FLA* |
| PRV-2 Griddle Fan | 1   | XCUE-140-VG | Direct     | 1,500           | 1.8                  | 1,801                      | 1,725           | 872.23                   | 1.33 | 92                | 65.55     | 12.12             | 0                       | 0          | 0            | 0.83                 | 1               | 0.73                 | OP        | 115     | 60    | 1     | VariGreer | 16       |

\*NEC FLA - Based on table 430.250 or 430.248 of National Electrical Code 2020. Actual motor FLA may vary for sizing thermal overload, consult factory"

**PRV-2 Griddle Fan - SELECTED OPTIONS AND ACCESSORIES**

One piece fully welded windband  
 Tapered bushing wheel hub  
 Breather tube outlet area min. 4.4 sq. in. (sizes 99-480), 2.0 sq. in. (sizes 60-95)  
 Min. windband material thickness: 0.051" aluminum (060-240), 0.064" aluminum (240HP, 240XP), 0.080" aluminum (sizes 300-480)  
 Larger Curb Cap Size - 26 Square  
 UL/cUL 705 Listed - Supplement SC - "Power Ventilators for Restaurant Exh. Appliances" (Formerly UL 762)  
 Switch, NEMA-3R, Toggle  
 Hinge, Factory Installed  
 High Temp Curb Seal Rated for Continuous Duty at 1500 F (Factory Attached)  
 Grease Trap (PN 475538)  
 Clean-out Port - Factory Installed  
 Aluminum Wheel Material

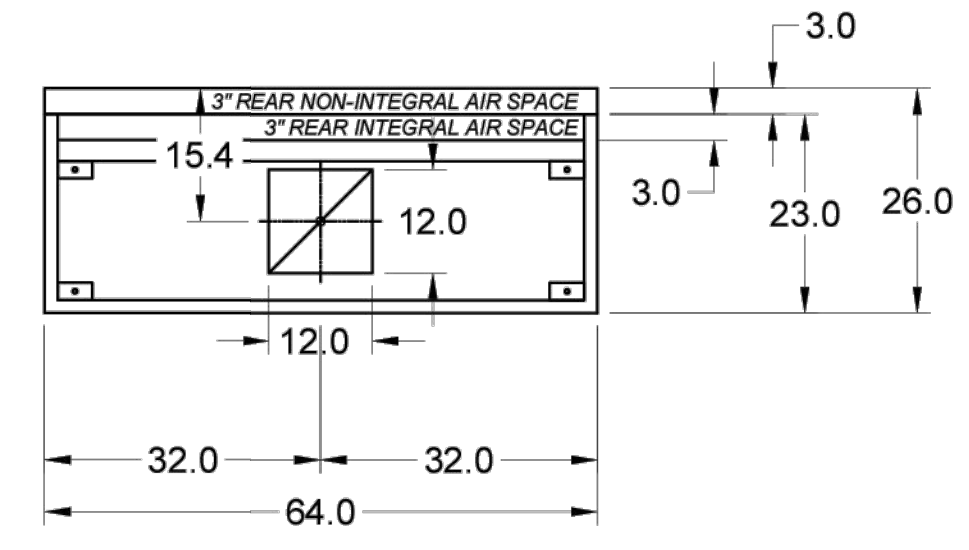
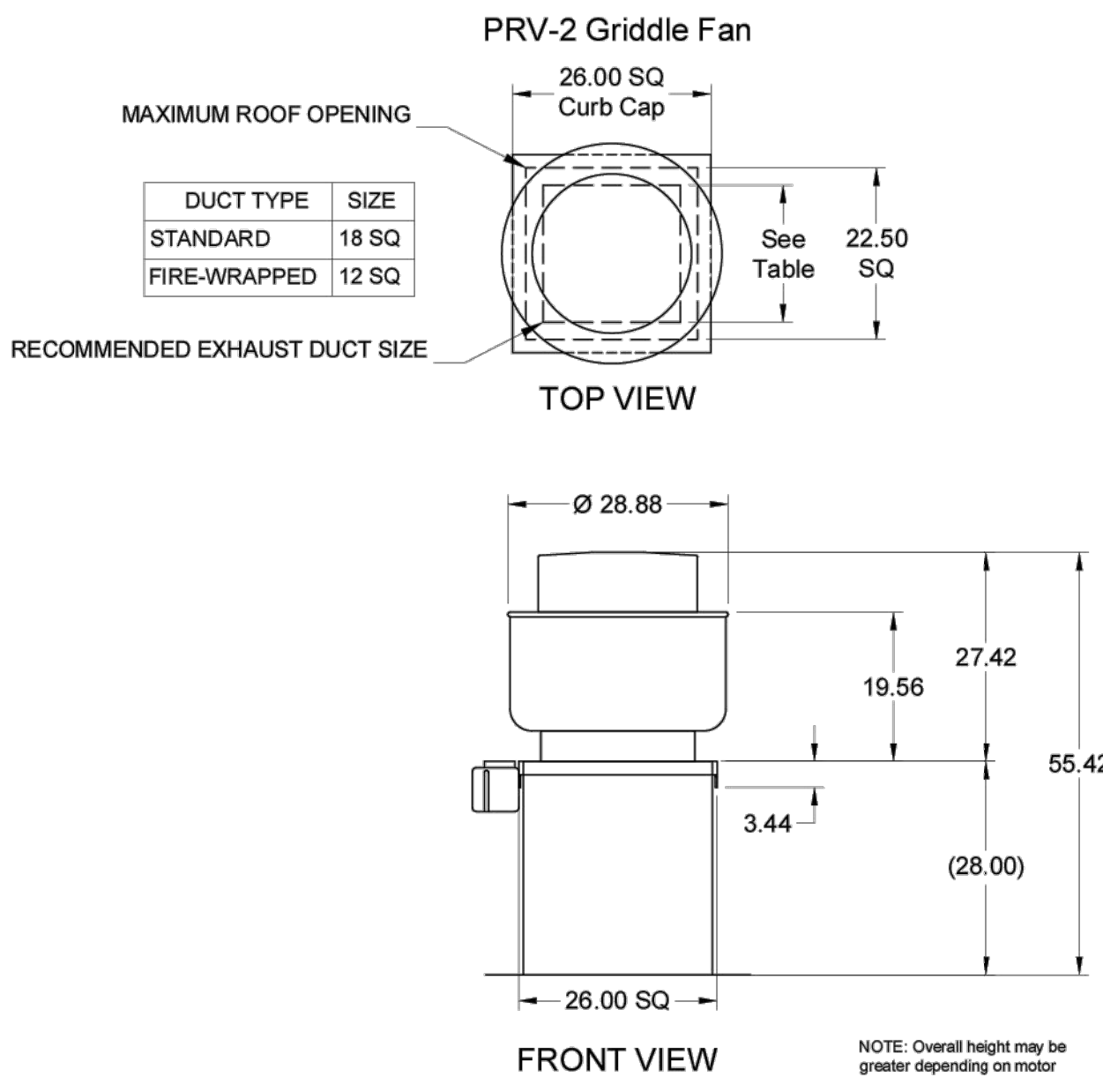

MUST USE WITH MAGIKITCH'N MODEL MKG-C-60 OR VULCAN MODEL VIG60-R3

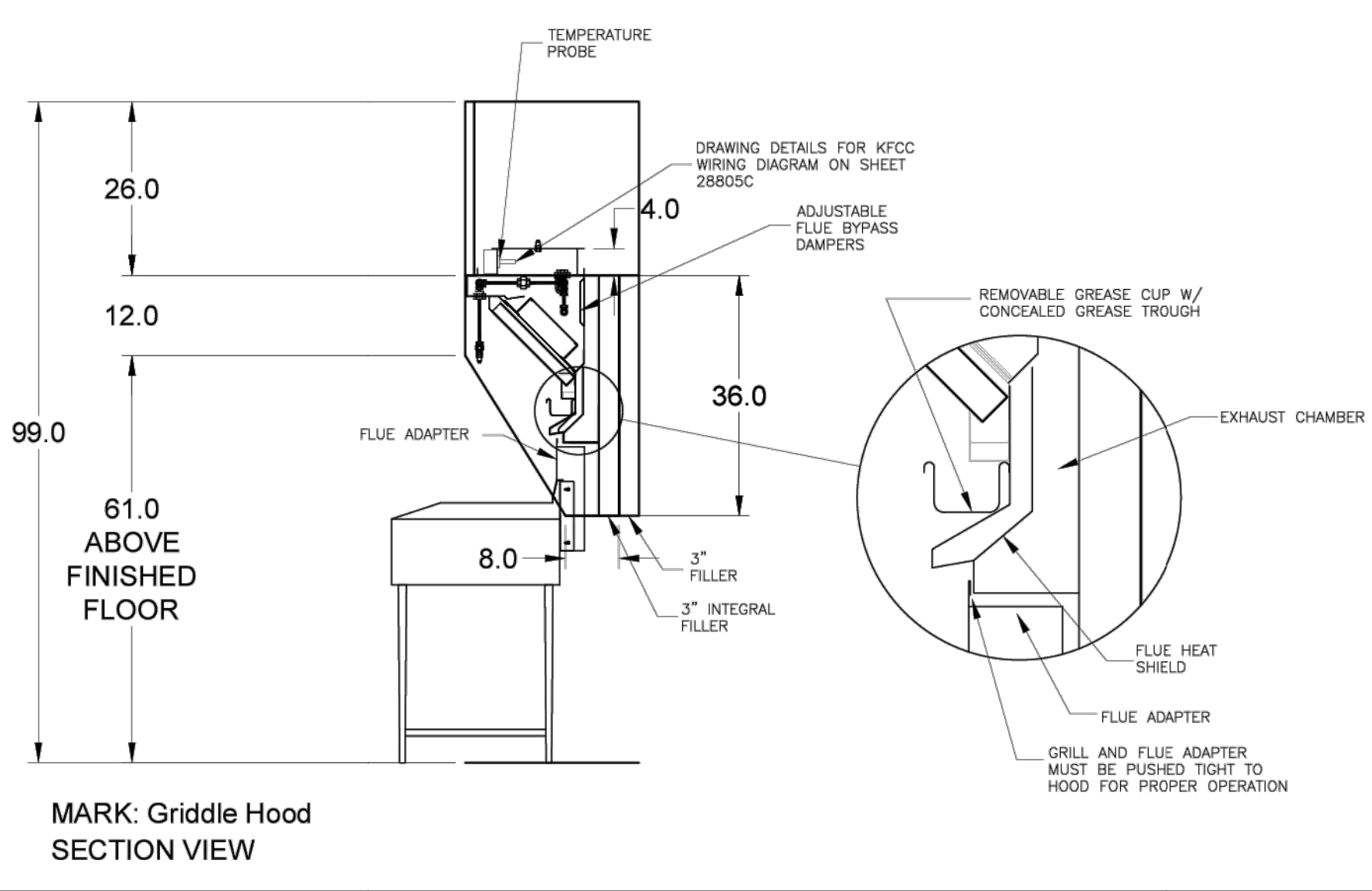
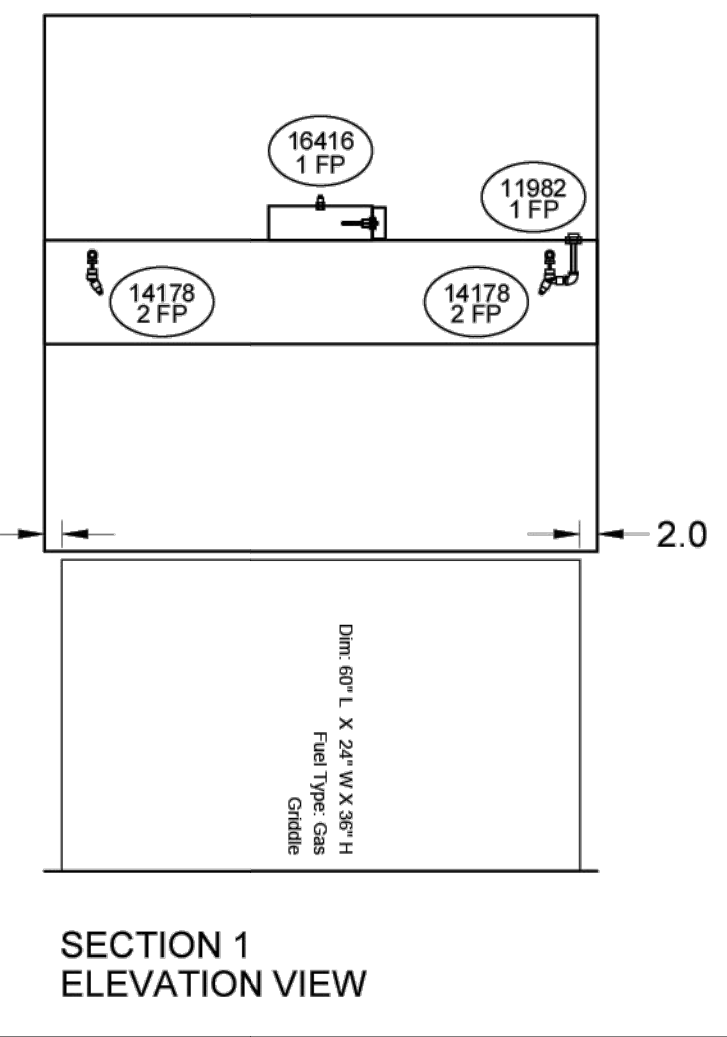
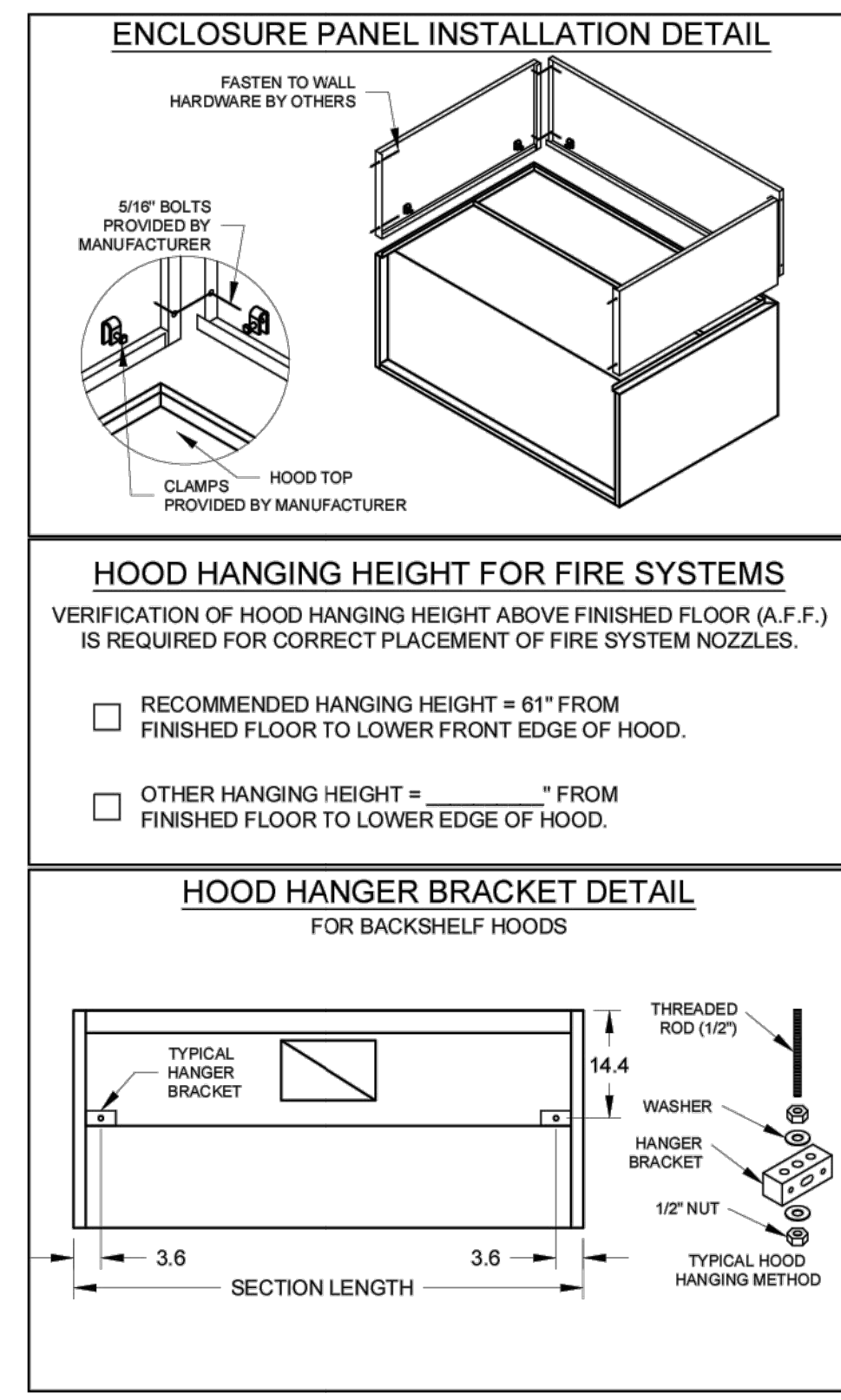
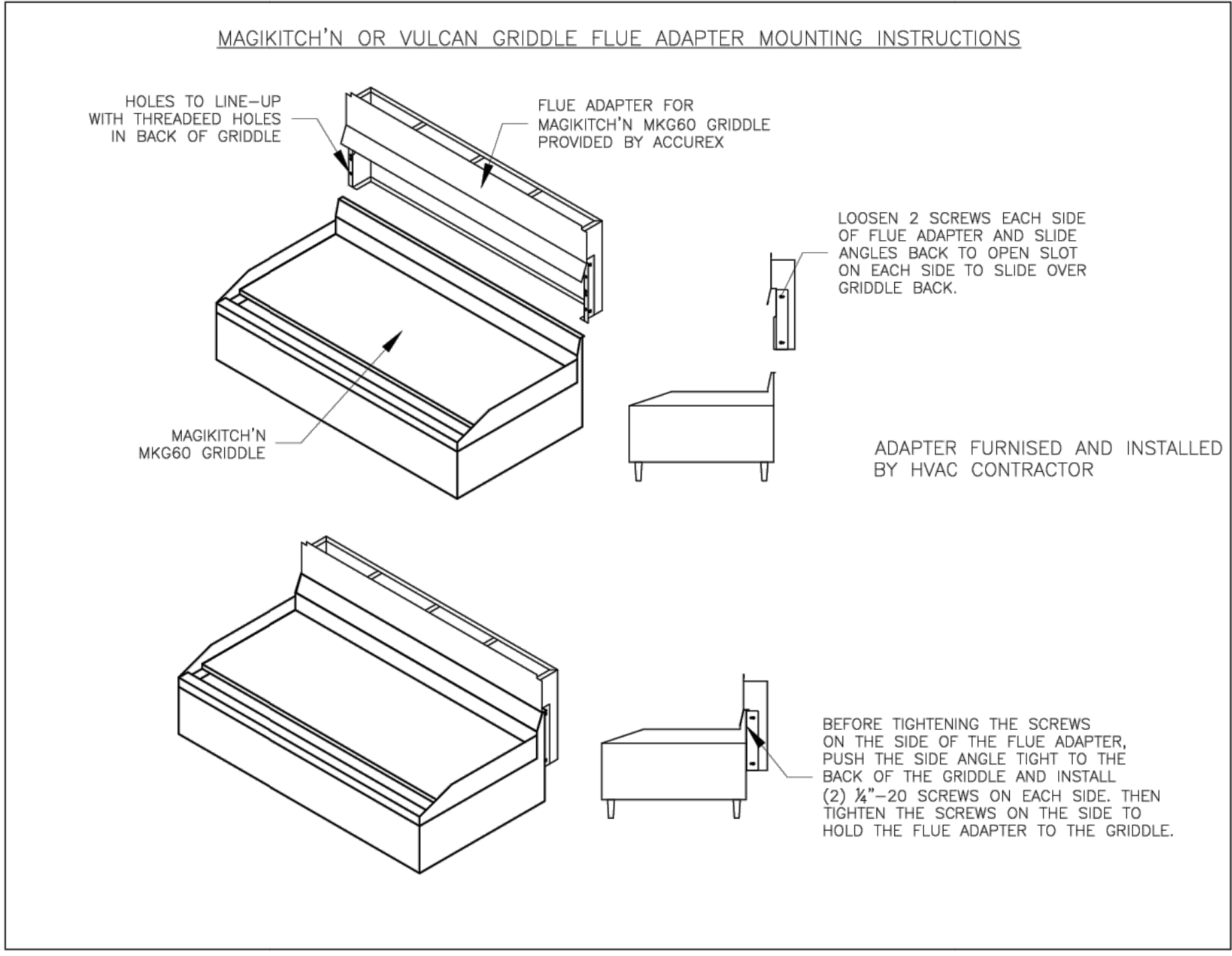
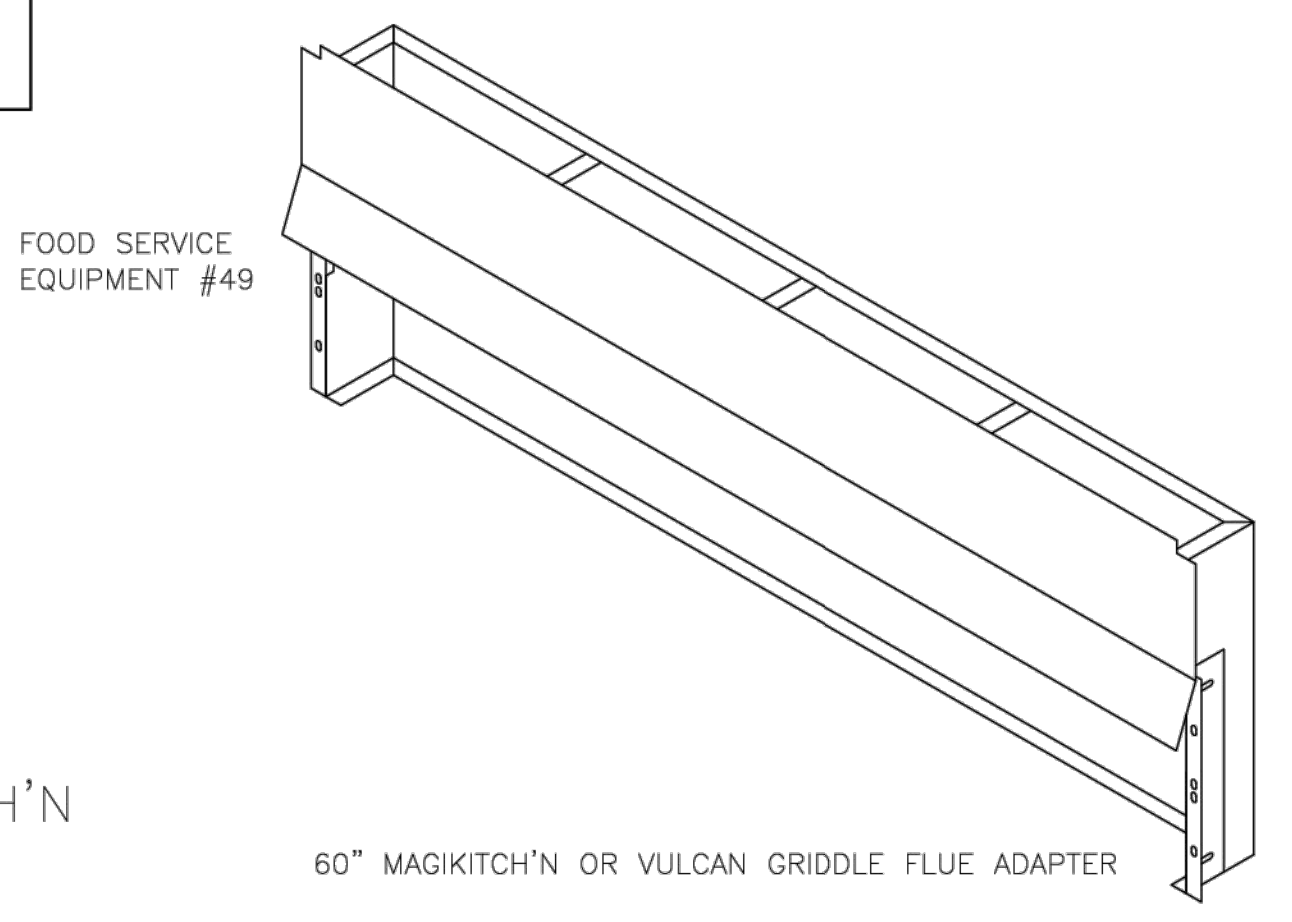

PROJECT: CULVERS  
 MARK: GRIDDLE HOOD PRV-2 GRIDDLE FAN  
 ACCUREX - W/LIA PHILLIP KRAFT  
 PHILLIP.KRAFT@ACCUREX.COM  
 262-227-7865  
**ACCUREX**

| DATE       | DESCRIPTION      |
|------------|------------------|
| 07/11/2025 | ISSUE FOR PERMIT |

NOTES:  
 THE INFORMATION PRESENTED HERE WAS NOT PREPARED BY THE ENGINEER OF RECORD AND IS PROVIDED FOR REFERENCE ONLY. FOR DOES NOT TAKE RESPONSIBILITY OF ANY ERROR OR OMISSIONS IN ABOVE DRAWINGS.

| HOOD INFORMATION |            |           |                       |                 |                   |                         |                            |           |                   |        |      |      |        |         |                   |                  |        |
|------------------|------------|-----------|-----------------------|-----------------|-------------------|-------------------------|----------------------------|-----------|-------------------|--------|------|------|--------|---------|-------------------|------------------|--------|
| HOOD NO.         | MARK       | MODEL     | HOOD DIMENSIONS (IN.) |                 |                   | HOOD CONSTR.            | COOKING LOAD / DUTY RATING | TOTAL CFM | EXHAUST COLLAR(S) |        |      |      | SUPPLY |         | TOTAL WEIGHT LBS. | SECTION LOCATION |        |
|                  |            |           | LENGTH                | WIDTH           | HEIGHT            |                         |                            |           | WIDTH             | LENGTH | DIA. | CFM  | S.P.   | MUA CFM |                   |                  | AC CFM |
| 1                | FRYER HOOD | XXEP-83-S | 83                    | TOP 23<br>BOT 3 | FRT 12<br>BACK 36 | 430 SS<br>WHERE EXPOSED | MEDIUM                     | 1500      | 12                | 12     |      | 1500 | 0.689  |         |                   | 169              | SINGLE |

| HOOD INFORMATION |            |                  |                  |     |              |                                  |                 |     |            |                    |             |      |       |
|------------------|------------|------------------|------------------|-----|--------------|----------------------------------|-----------------|-----|------------|--------------------|-------------|------|-------|
| HOOD NO.         | MARK       | LIGHTING DETAILS |                  |     |              | GREASE FILTRATION DETAILS        |                 |     |            | UTILITY CABINET(S) |             |      |       |
|                  |            | FIXTURE TYPE     | BULB / LAMP INFO | QTY | FOOT CANDLES | TYPE / MODEL                     | MATERIAL        | QTY | SIZE (IN.) | LOCATION           | FIRE SYSTEM | SIZE | MODEL |
| 1                | FRYER HOOD |                  |                  |     |              | X-TRACTOR (SPARK ARRESTOR INCL.) | STAINLESS STEEL | 5   | 16         |                    |             |      |       |
|                  |            |                  |                  |     |              |                                  |                 | 0   | 20         | 16                 |             |      |       |

**HOOD OPTIONS**  
 UL 710 LISTED W/ OUT EXHAUST FIRE DAMPER - UL #R25625  
 BACK NON-INTEGRAL AIR SPACE - 3 IN WIDE  
 26 IN HIGH CEILING ENCLOSURES - FRONT LEFT RIGHT - FIELD INSTALLED  
 FACTORY MOUNTED EXHAUST COLLAR(S)  
 PERFORMANCE ENHANCING LIP (PEL) TECHNOLOGY  
 STANDING SEAM CONSTRUCTION FOR SUPERIOR STRENGTH

**SPECIAL DESIGN REQUESTS**  
 SDR #K2400335 - CULVERS PITCO FRYER FLUE BYPASS, AMEREX FIRE, GX  
 SDR #K2400437 - CULVERS FRYMASTER FRYER FLUE BYPASS, AMEREX FIRE, GX  
 SDR #K2400436 - CULVERS AMEREX SHARED FIRE SYSTEM PROCESS  
 \*APPLY SDR FOR OTHER PITCO OR FRYMASTER FRYER, DEPENDING ON WHICH IS BEING USED

| Direct Drive Upblast Centrifugal Roof Exhaust Fan |     |             |            |                 |                      |                            |                 |                          |      |                   |           |                   |                         |            |              |                      |                 |                      |           |         |       |       |           |          |
|---|-----|-------------|------------|-----------------|----------------------|----------------------------|-----------------|--------------------------|------|-------------------|-----------|-------------------|-------------------------|------------|--------------|----------------------|-----------------|----------------------|-----------|---------|-------|-------|-----------|----------|
| MARK INFORMATION                                  |     |             |            | FAN INFORMATION |                      |                            |                 | SOUND INFORMATION        |      |                   |           | MOTOR INFORMATION |                         |            |              |                      |                 |                      |           |         |       |       |           |          |
| MARK  | QTY | MODEL       | DRIVE TYPE | VOLUME (CFM)    | EXTERNAL SP (IN. WG) | TOTAL EXTERNAL SP (IN. WG) | FAN SPEED (RPM) | OUTLET VELOCITY (FT/MIN) | FEI  | TOTAL WEIGHT (LB) | INLET dBA | INLET SONES       | INLET SONES (SPHERICAL) | OUTLET dBA | OUTLET SONES | OPERATING POWER (HP) | MOTOR SIZE (HP) | FEP INPUT POWER (KW) | ENCLOSURE | VOLTAGE | CYCLE | PHASE | EC MOTOR  | NEC FLA* |
| PRV-3 Fryer Fan                                   | 1   | XCUE-140-VG | Direct     | 1,500           | 1                    | 1                          | 1,349           | 872.09                   | 1.62 | 92                | 61.1      | 11.56             | 0                       | 0          | 0            | 0.46                 | 1               | 0                    | OP        | 115     | 60    | 1     | VariGreen | 16       |

\*NEC FLA - Based on table 430.250 or 430.248 of National Electrical Code 2020. Actual motor FLA may vary for sizing thermal overload, consult factory"

**PRV-3 Fryer Fan : SELECTED OPTIONS AND ACCESSORIES**

One piece fully welded windband  
 Tapered bushing wheel hub  
 Breather tube outlet area min. 4.4 sq. in. (sizes 99-480), 2.0 sq. in. (sizes 60-95)  
 Min. windband material thickness: 0.051" aluminum (060-240), 0.064" aluminum (240HP, 240XP), 0.080" aluminum (sizes 300-480)  
 Larger Curb Cap Size - 26 Square  
 UL/cUL 705 Listed - Supplement SC - "Power Ventilators for Restaurant Exh. Appliances" (Formerly UL 762)  
 Switch, NEMA-3R, Toggle.  
 Hinge, Factory Installed  
 High Temp Curb Seal Rated for Continuous Duty at 1500 F (Factory Attached)  
 Grease Trap (PN 475538)  
 Clean-out Port - Factory Installed  
 Aluminum Wheel Material

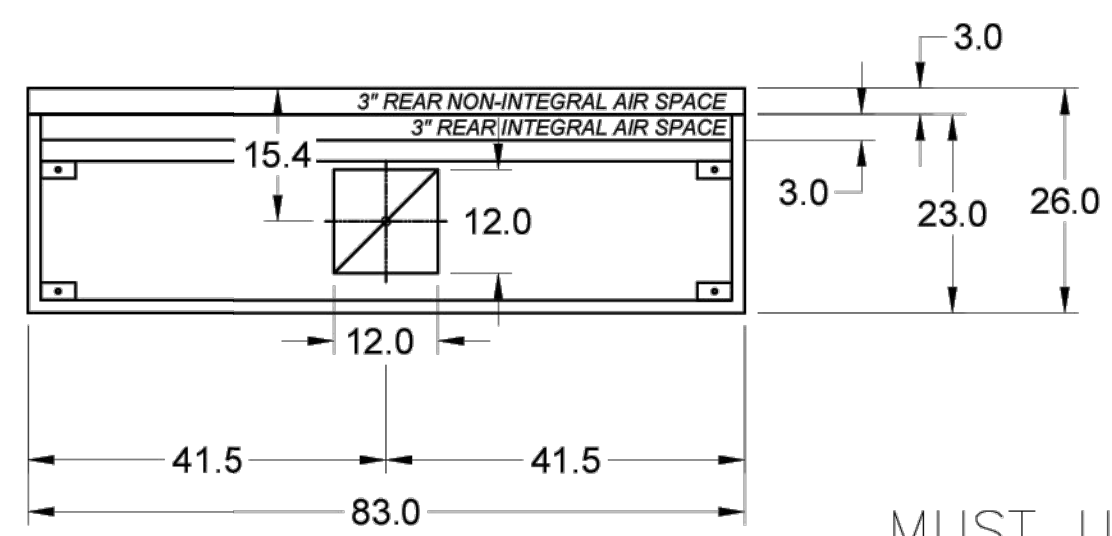
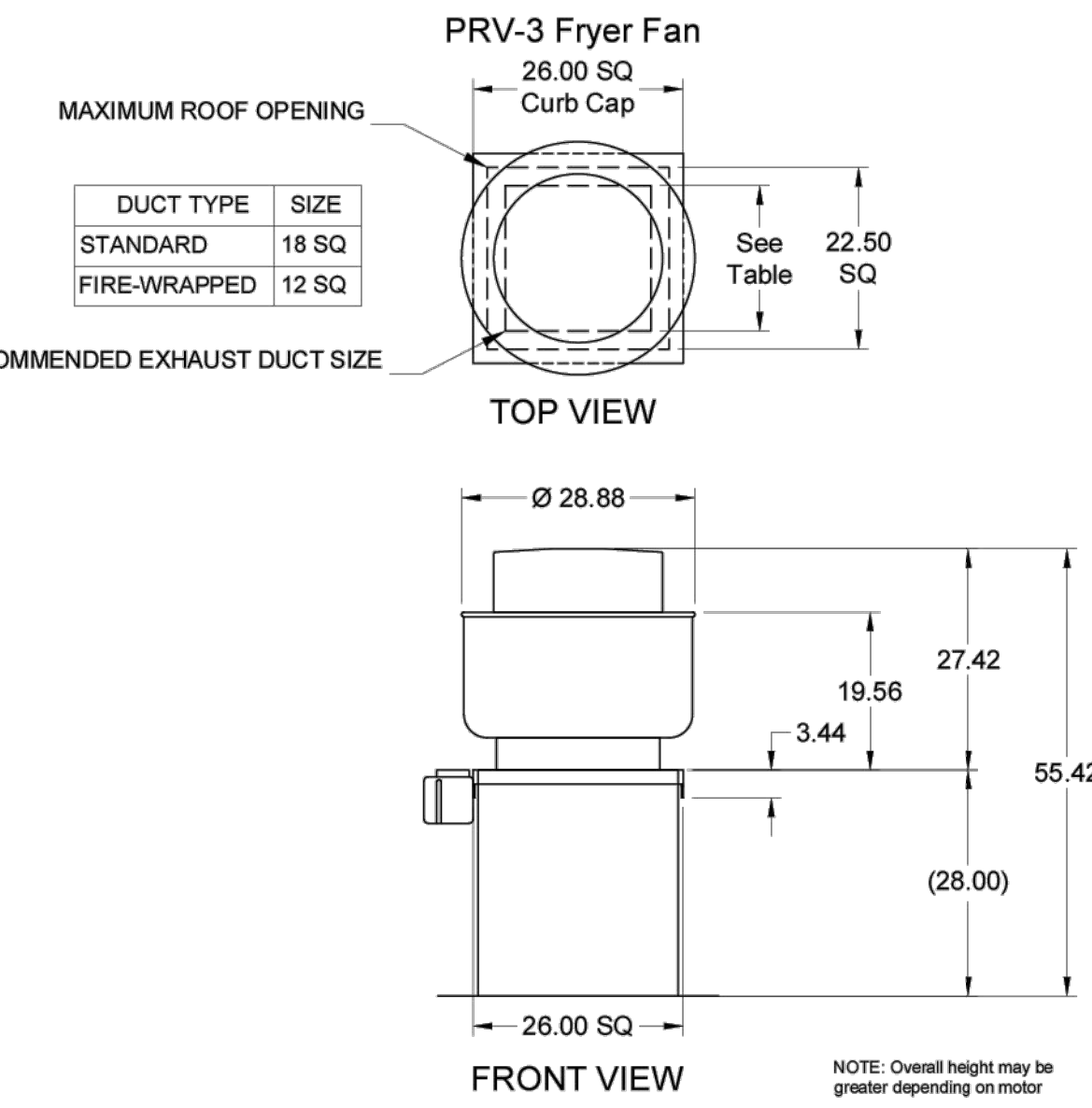

MUST USE WITH PITCO MODEL CU-SSH60W/WR 4-VAT FRYER IF FRYMASTER MODEL 41814GF-CFS IS BEING USED, NOTIFY ACCUREX REP

PITCO MODEL CU-SSH60W/WR 4-VAT FRYER FLUE ADAPTER OR FRYMASTER MODEL 41814GF-CFS

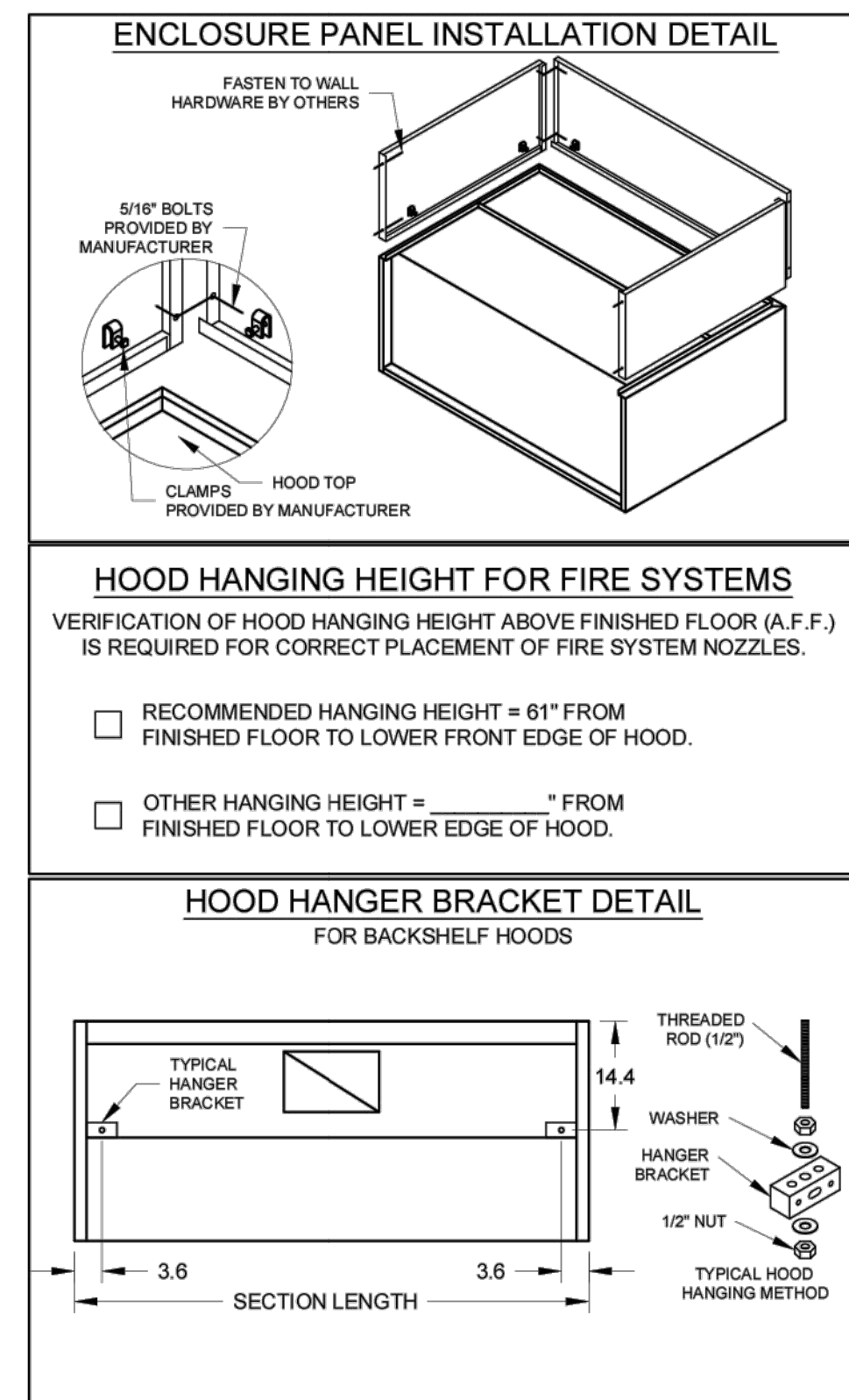
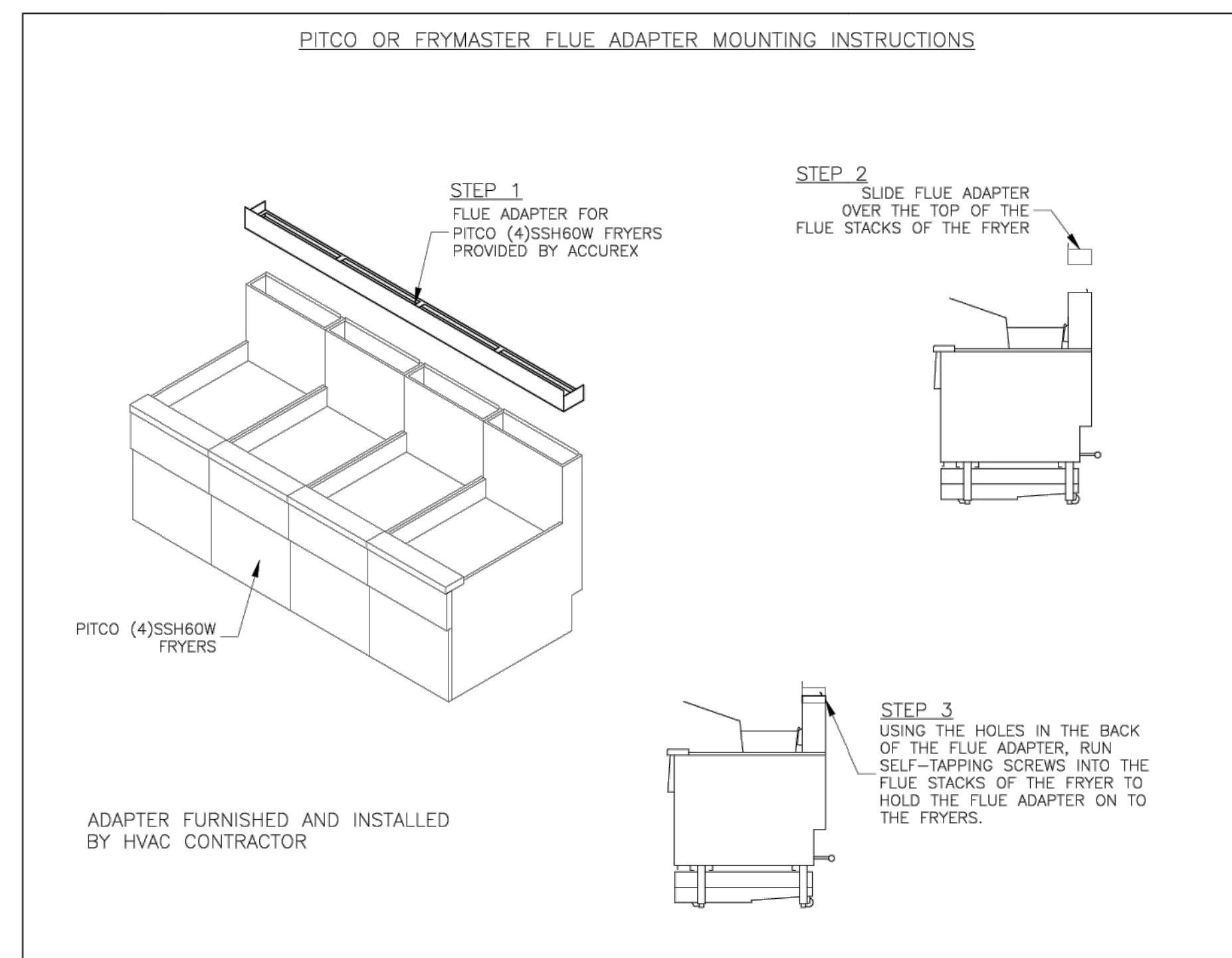
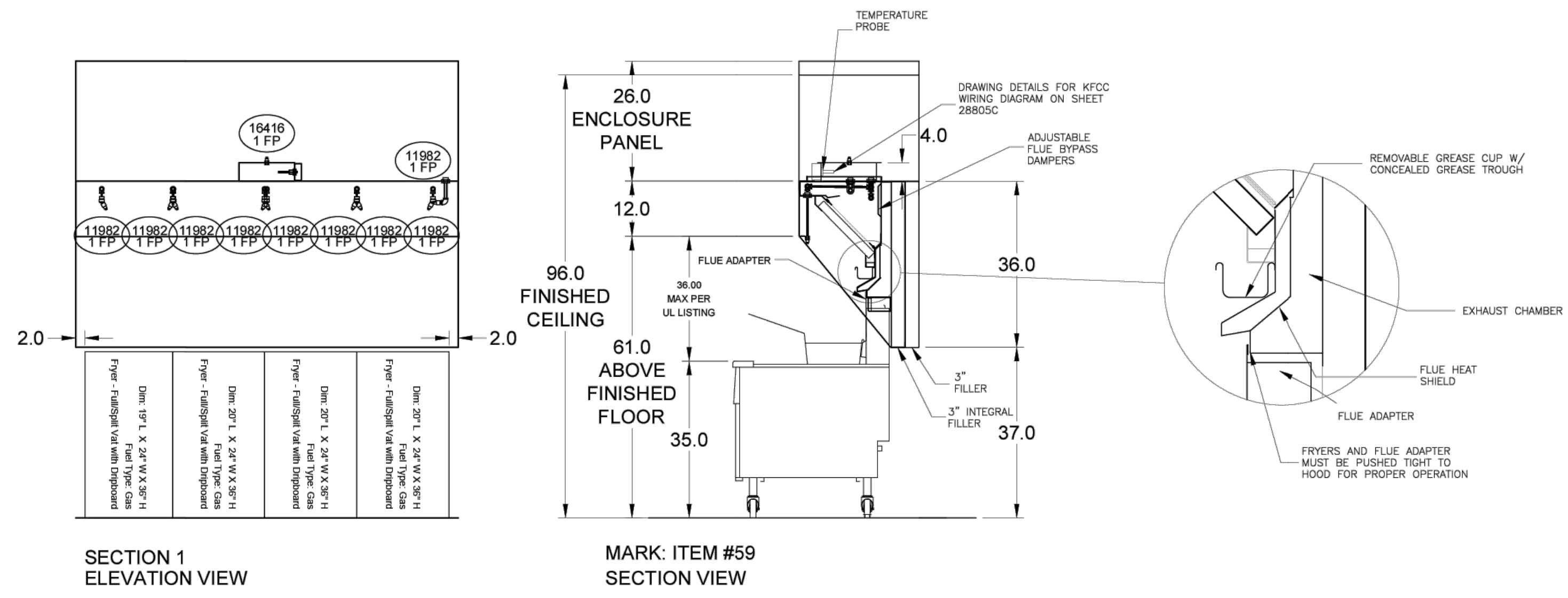

**ACCUREX**

ACCUREX - W/ IA  
 PHILLIP KRAFT  
 PHILLIP.KRAFT@ACCUREX.COM  
 262-227-7865

CULVERS

FRYER HOOD  
 PRV-3 FRYER FAN

NOTES:  
 THE INFORMATION PRESENTED HERE WAS NOT PREPARED BY THE ENGINEER OF RECORD AND IS PROVIDED FOR REFERENCE ONLY. FOR DOES NOT TAKE RESPONSIBILITY OF ANY ERROR OR OMISSIONS IN ABOVE DRAWINGS.

PMT25-12454





