

**HOOD INFORMATION - JOB#4604989**

HOOD NO	TAG	MODEL	MANUFACTURER	LENGTH	MAX COOKING TEMP	TYPE	APPLIANCE DUTY	DESIGN CFM/FT	TOTAL EXH CFM	EXHAUST PLENUM RISER(S)							HOOD CONSTRUCTION	HOOD CONFIG	
										WIDTH	LENG	HEIGHT	DIA	CFM	VEL	SP		END TO END	ROW
1	HDI-VDR1	5424 ND-2	CAPTIVEAIRE	10' 0"	600 DEG	I	HEAVY	160	1600			4'	14'	1600	1497	-0.341'	430 SS WHERE EXPOSED	ALONE	ALONE

**HOOD INFORMATION**

HOOD NO	TAG	FILTER(S)					LIGHT(S)					UTILITY CABINET(S)				FIRE SYSTEM PIPING	HOOD HANGING WEIGHT				
		TYPE	QTY	HEIGHT	LENGTH	EFFICIENCY @ 7 MICRONS	QTY	TYPE	WIRE GUARD	LOCATION	SIZE	FIRE SYSTEM		ELECTRICAL	SWITCHES						
1	HDI-VDR1	SS BAFFLE WITH HANDLES	7	16"	16"	30%	4	L55 SERIES E26	NO											NO	453 LBS

**HOOD OPTIONS**

HOOD NO	TAG	OPTION
1	HDI-VDR1	FIELD WRAPPER 15.00' HIGH FRONT, LEFT, RIGHT. RIGHT QUARTER END PANEL 23' TOP WIDTH, 0' BOTTOM WIDTH, 23' HIGH 430 SS. LEFT QUARTER END PANEL 23' TOP WIDTH, 0' BOTTOM WIDTH, 23' HIGH 430 SS. SENSOR-CV.

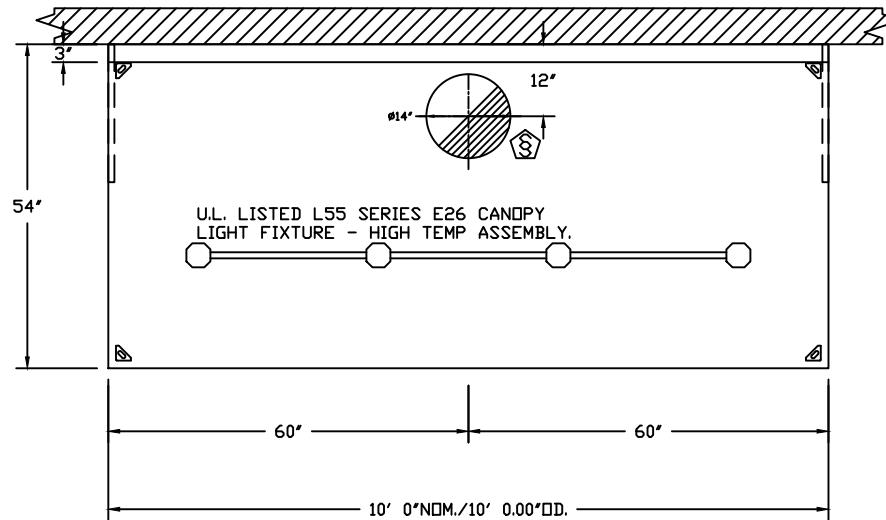

PLAN VIEW - HOOD #1 (HDI-VDR1)  
10' 0.00" LONG 5424ND-2

**VENDOR 1**



**CAPTIVEAIRE**

JOB West Social FoodHall (Dayton)	
LOCATION Dayton, OH, 45402	
DATE 12/23/2021	JOB # 4604989
DWG # 1	DRAWN BY jcirilli
REV.	SCALE 3/8" = 1'-0"

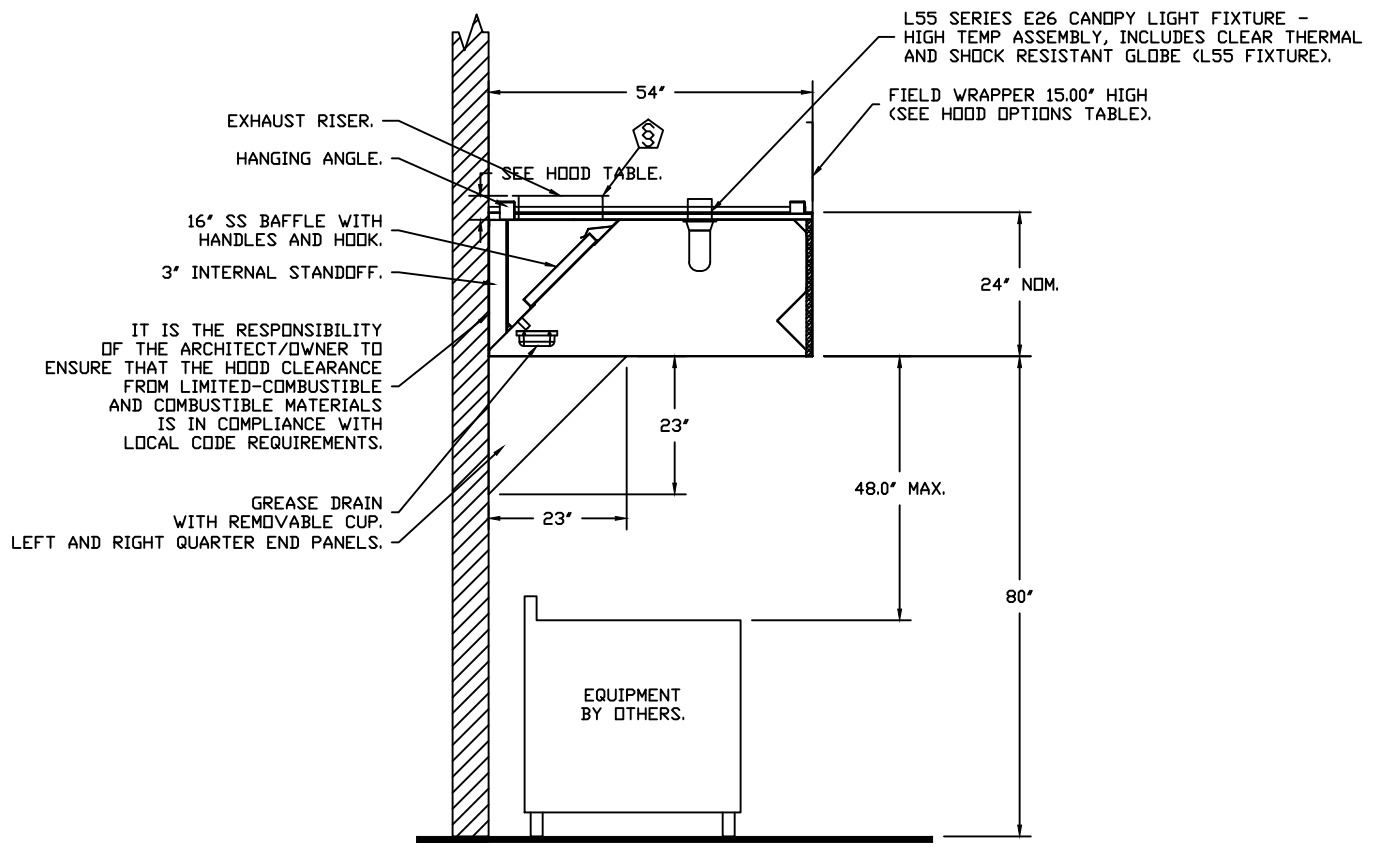

SECTION VIEW - MODEL 5424ND-2  
HOOD - #1 (HD1-VDR1)

**VENDOR 1**



**CAPTIVEAIRE**

JOB West Social FoodHall (Dayton)	
LOCATION Dayton, OH, 45402	
DATE 12/23/2021	JOB # 4604989
DWG # 2	DRAWN BY jcirilli
REV.	SCALE 3/8" = 1'-0"

**EXHAUST FAN INFORMATION - JOB#4604989**

FAN UNIT NO	TAG	QTY	FAN UNIT MODEL #	MANUFACTURER	CFM	ESP	RPM	MOTOR ENCL	HP	BHP	PHASE	VOLT	FLA	DISCHARGE VELOCITY	WEIGHT (LBS)	SDINES
1	EF-VDR1	1	DUBSHFA	CAPTIVEAIRE	1600	1.150	1376	TEAD-ECM	1.000	0.4590	1	115	11.6	506 FPM	93	13

**FANS #1 (EF-VDR1) - DUBSHFA EXHAUST FAN**

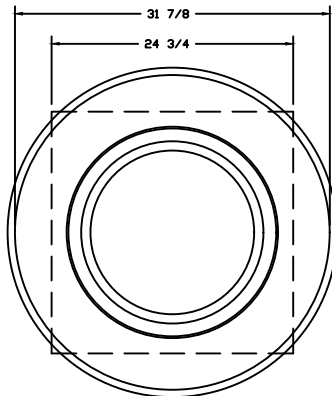
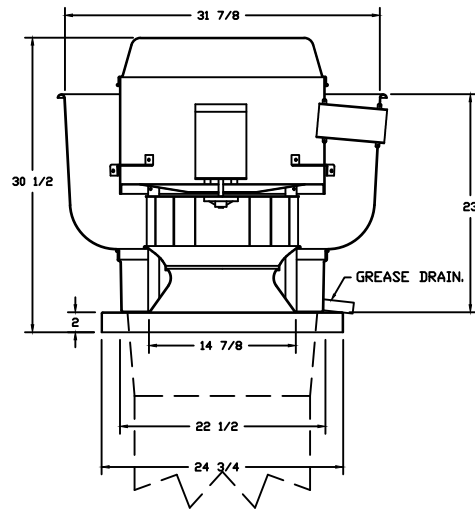

TOP VIEW

**FEATURES:**

- DIRECT DRIVE CONSTRUCTION (NO BELTS/PULLEYS).
- ROOF MOUNTED FANS.
- RESTAURANT MODEL.
- UL705 AND UL762 AND ULC-S645
- VARIABLE SPEED CONTROL.
- INTERNAL WIRING.
- THERMAL OVERLOAD PROTECTION (SINGLE PHASE).
- HIGH HEAT OPERATION 300°F (149°C).
- GREASE CLASSIFICATION TESTING.
- NEMA 3R SAFETY DISCONNECT SWITCH.

**NORMAL TEMPERATURE TEST**

EXHAUST FAN MUST OPERATE CONTINUOUSLY WHILE EXHAUSTING AIR AT 300°F (149°C) UNTIL ALL FAN PARTS HAVE REACHED THERMAL EQUILIBRIUM, AND WITHOUT ANY DETERIORATING EFFECTS TO THE FAN WHICH WOULD CAUSE UNSAFE OPERATION.

**ABNORMAL FLARE-UP TEST**

EXHAUST FAN MUST OPERATE CONTINUOUSLY WHILE EXHAUSTING BURNING GREASE VAPORS AT 600°F (316°C) FOR A PERIOD OF 15 MINUTES WITHOUT THE FAN BECOMING DAMAGED TO ANY EXTENT THAT COULD CAUSE AN UNSAFE CONDITION.

**OPTIONS**

- GREASE BOX.
- EXHAUST FAN HEAT BAFFLE.
- ECM WIRING PACKAGE - PWM
- SIGNAL FROM ECPM03 PREWIRE (TELCO MOTOR), CCW ROTATION.
- 2 YEAR PARTS WARRANTY.

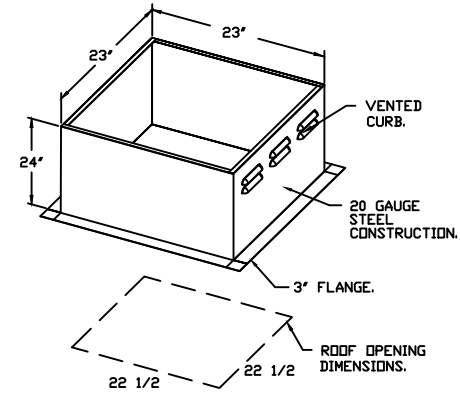

PITCHED CURBS ARE AVAILABLE FOR PITCHED ROOFS.

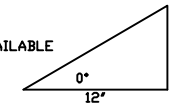

SPECIFY PITCH:  
EXAMPLE: 7/12 PITCH = 30° SLOPE.

**VENDOR 1**



**CAPTIVEAIRE**

JOB West Social FoodHall (Dayton)	
LOCATION Dayton, OH, 45402	
DATE 12/23/2021	JOB # 4604989
DWG # 3	DRAWN BY jcirilli
REV.	SCALE 3/8" = 1'-0"

**DUCTWORK #1 PARTS - JOB#4604989 DR-1 GREASE**

TAG	PART #	CFM	GPM	ZONE	COVEREDBY	SP	WEIGHT	VELOCITY	QTY	DESCRIPTION
P1	DW1445ASY	1600				-0.0368	7.22	1496.71	1	SINGLE WALL DUCT 45 DEGREE ELBOW, 14" DUCT, ASSEMBLY.
P2	DW1411LT	1600				-0.0039	5.46	1496.71	1	SINGLE WALL DUCT 14" DIAMETER, 11" LONG, FLANGE AT BOTH ENDS. STAINLESS STEEL.
P3	DW1418AJDKIT	1600				-0.0021	11.56	1496.71	1	SINGLE WALL DUCT ADJUSTABLE, 14" DIAMETER, 17.5" LONG, FLANGE AT ONE END WITH A 14" ADJUSTABLE COLLAR - STAINLESS STEEL.
P4	DW14SUBRASY						2.96		1	DUCT SUPPORT BRACKET KIT, 14" DUCT, USED FOR HANGING DUCT. 12 GA STEEL, CLEAR ZINC COATING. - 2 RINGS, 4 BRACKETS, & HARDWARE BAG 2.
P5	DW1445ASY	1600				-0.0525	7.22	1496.71	1	SINGLE WALL DUCT 45 DEGREE ELBOW, 14" DUCT, ASSEMBLY.
P6	DW1435LT	1600				-0.0119	16.34	1496.71	1	SINGLE WALL DUCT 14" DIAMETER, 35" LONG, FLANGE AT BOTH ENDS. STAINLESS STEEL.
P7 ASSEMBLED W/P8	DW1430AJDKIT	1600				-0.0041	17.56	1496.71	1	SINGLE WALL DUCT ADJUSTABLE, 14" DIAMETER, 29.5" LONG, FLANGE AT ONE END WITH A 14" ADJUSTABLE COLLAR - STAINLESS STEEL.
P8 ASSEMBLED W/P7	DW2314TPDBEX	1600					8.00	1496.71	1	DUCT TO CURB TRANSITION 3/4" DOWN TURN, 23' CURB TO 14" DUCT, 16 GA ALUMINIZED. USED ON NCA14FA & NCA14HPPA. TRANSITION PLATE DD IS 23.5" DESIGNED FOR USE WITH EXHAUST FAN. NON-STANDARD PART.
SYSTEM AT P8						-0.4523	0.00			
	3M-2000PLUS						0.80		2	DUCT - 3M FIRE BARRIER 2000 PLUS SILICONE - USED AS SEALANT TO SEAL DUCT JOINTS.
	DW14CLASY						1.06		6	DUCT "V" CLAMP WITH NEW DESIGN 14 GA BRACKETS, 14" DUCT, ASSEMBLY.
TOTAL WEIGHT							84.28			

DUCTWORK #1 FRONT VIEW  
DR-1 GREASE

DUCTWORK #1 SIDE VIEW  
DR-1 GREASE

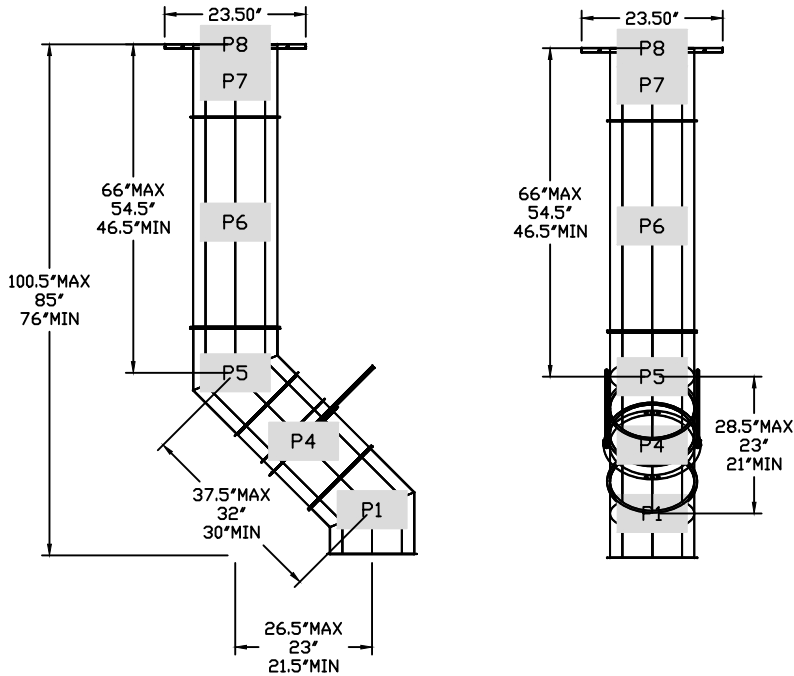

**GREASE DUCT SPECIFICATION - SINGLE WALL**

FURNISH SINGLE-WALL, FACTORY BUILT, GREASE DUCT FOR USE WITH TYPE I KITCHEN HOODS, WHICH CONFORMS TO THE REQUIREMENTS OF NFPA-96. PRODUCTS SHALL BE ETL LISTED TO UL-1978 FOR VENTING AIR AND GREASE VAPORS FROM COMMERCIAL COOKING OPERATIONS AS DESCRIBED IN NFPA-96. THE DUCT WALL SHALL BE CONSTRUCTED OF .036 THICK TYPE 430 STAINLESS STEEL AND BE AVAILABLE IN DIAMETERS 8" THROUGH 24". ALL SUPPORTS, FAN ADAPTERS, HOOD CONNECTIONS, FITTINGS AND EXPANSION JOINTS REQUIRED TO INSTALL GREASE DUCT SHALL BE INCLUDED. ROOF PENETRATIONS SHALL COMPLY WITH LISTED CLEARANCE TO COMBUSTIBLES, SEE "CLEARANCE TO COMBUSTIBLES" GUIDE FOR DETAILS. THE GREASE DUCT WILL TERMINATE AT THE FAN ADAPTER PLATE, WILL BE FULLY WELDED TO THE FAN ADAPTER PLATE AND THE FAN ADAPTER PLATE WILL BE FASTENED TO THE CURB USING A SUITABLY SIZED FASTENER PROVIDED BY OTHERS; SEE PAGE 12 OF THE "INSTALLATION, OPERATION AND MAINTENANCE MANUAL" FOR DETAILS. GREASE DUCT JOINTS SHALL BE HELD TOGETHER BY MEANS OF FORMED VEE CLAMPS AND SEALED WITH 3M FIRE BARRIER 2000+. SCREWS USED TO SECURE THE VEE CLAMPS SHALL BE OF THE HEX-HEAD TYPE WITH FLANGED STOPS AND TAPERED "LEAD IN" THREADS FOR EASY STARTING. NUTS SHALL BE RETAINED BY MEANS OF A FREE-FLOATING CAGE TO ALLOW EASY ALIGNMENT. SINGLE-WALL GREASE DUCT SHALL BE INSTALLED IN ACCORDANCE WITH THE MANUFACTURER'S "INSTALLATION, OPERATION AND MAINTENANCE MANUAL", ETL LISTING AND STATE AND LOCAL CODES. GREASE DUCT INSTALLED OUTSIDE OF THE BUILDING SHALL BE PROTECTED AGAINST ACCIDENTAL DAMAGE OR VANDALISM. SUPPORT VERTICALLY INSTALLED GREASE DUCT FROM THE BUILDING STRUCTURE USING RIGID STRUCTURAL SUPPORTS. ANCHOR SUPPORTS TO THE STRUCTURE BY WELDING OR BOLTING STEEL EXPANSION ANCHORS OR CONCRETE INSERTS. SUPPORT HORIZONTALLY INSTALLED GREASE DUCT FROM THE BUILDING STRUCTURE USING ABOVE METHOD OR USE DUCT MATE, WIRE ROPE & CLUTCHERS, PART NUMBERS WR20 & CL20. 1/2" THREADED ROD AND SADDLES MAY ALSO BE USED FOR THE SUPPORT OF HORIZONTAL GREASE DUCT. FANS SHALL BE SUPPORTED INDEPENDENTLY FROM THE GREASE DUCT SECTIONS. PROTECT GREASE DUCT FROM TWISTING OR MOVEMENT CAUSED BY FAN TORQUE OR VIBRATION.

**VENDOR 1**



**CAPTIVEAIR**

JOB West Social FoodHall (Dayton)	
LOCATION Dayton, OH, 45402	
DATE 12/23/2021	JOB # 4604989
DWG # 4	DRAWN BY jcirilli
REV.	SCALE 3/8" = 1'-0"



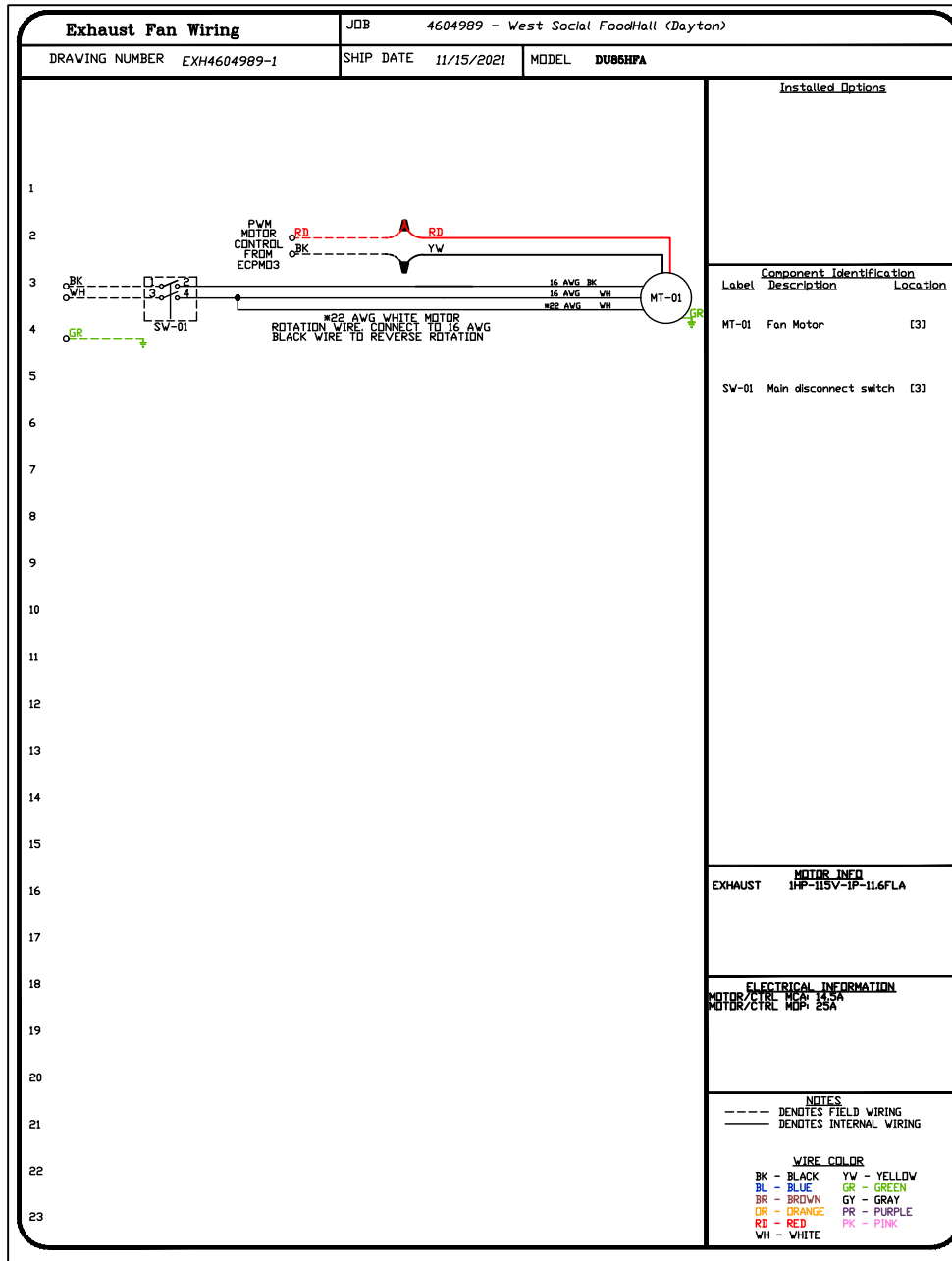

# VENDOR 1



# CAPTIVEAIRE

JOB West Social FoodHall (Dayton)	
LOCATION Dayton, OH, 45402	
DATE 12/23/2021	JOB # 4604989
DWG # 5	DRAWN BY jcirilli
REV.	SCALE 3/8" = 1'-0"