



Submittal Transmittal

Project: DCH - Ambulatory Renewal

Date: 9/15/2021

Transmitted To:

Derek Shaw
Heapy
1400 W Dorthy Lane
Dayton, Ohio 45409
dashaw@heapy.com

Transmitted By:

Greg Myak
Danis Building Construction Company
One Children's Plaza
Dayton, Ohio 45404
Phone: 937-271-7086
richard.markwell@danis.com

Submittal No. Submitted By: Contact:

630-233616-001

Cinfab

Jacob Degen

Specification Section Description Status

233616

3rd Floor VAVs

OPEN

Submitted For Copies

Approval

1

Please review & return 1 electronic copy of submittals in accordance with the contract specifications.

Danis Stamp:

REVIEWED by DANIS

Review does not relieve subcontractor or supplier from its obligation to perform its work complete, in strict accordance with the plans, specifications, subcontract, purchase order or other provisions of the contract documents. Review also does not relieve subcontractor or supplier from its responsibility for checking dimensions on the drawings and on the job or the proper matching and fitting of its work with contiguous work and the coordination its work with other work on the construction site.

Date: 9/15/2021 By Greg Myak

Submittal No. _____

A/E Stamps:

REVIEWED BY HEAPY

FOR GENERAL CONFORMANCE WITH INFORMATION PRESENTED IN THE CONTRACT DOCUMENTS ONLY.

APPROVED AS NOTED

BY: DEREK SHAW/ VICTORIA FRANCIS DATE: 9/23/2021

Comments:

Product Data:

Comments:



SUBMITTAL DATA

Project: Dayton Children’s Hospital Ambulatory

Project No.: 21113841

Construction Manager: Danis Construction

Architect/Engineer: Champlin/Heapy

Submittal For: 3rd Floor Electric VAVs

Specification #: 23 36 16

Manufacturer: Nailor

Supplier: ProFit HVAC

Contact Name & Phone #: Todd Klosterman (419) 305-7629

The attached submittal data has been reviewed by CINFAB for compliance with the Architect/Engineer's specifications and plan schedule for this project.

In order to maintain the project schedule, we request that this submittal be returned to CINFAB **within 10 days**.

NOTE: Material cannot be released without Architect/Engineer's approval of submittal.

Reviewed By: Jake Degen

Date: September 14, 2021

(Please place stamp of approval here)



Pro Fit HVAC, LLC

P.O. Box 443
15713 St. Rt. 116
St. Marys, OH 45885

Todd Klosterman
Cell: 419-305-7629
todd@proairsales.com

Emily Klosterman
Cell: 419-733-4733
emily@proairsales.com

SUBMITTAL TRANSMITTAL

Project No.: 2018-05111

NOTE:

Third Floor

Project Description: *(Project Title, Facility Name and Address)*

Dayton Children's
Ambulatory Renewal Project

Date: 9/13/21

TO:

Cinfab LLC
5240 Lester Road
Cincinnati, OH 45213

FROM:

PRO FIT HVAC, LLC
PO BOX 443
ST. MARYS, OH 45885

SUBMITTAL TYPE:

- | | | |
|--|--|--|
| <input checked="" type="checkbox"/> For Approval | <input type="checkbox"/> Re-Submittal | <input type="checkbox"/> Information |
| <input type="checkbox"/> Product Data | <input type="checkbox"/> Shop Drawings | <input type="checkbox"/> Quality Control/Assurance |
| <input type="checkbox"/> Test Reports | <input type="checkbox"/> Certificate | <input type="checkbox"/> Contract Closeout |
| <input type="checkbox"/> Design Data | <input type="checkbox"/> Samples | <input type="checkbox"/> Other |

Specification Number and Title: _____

Part	Type	Description
23 36 16	Air Terminal Units	Nailor Industries

Contractor's Certification:

We have verified that all material or equipment contained in this submittal meets all the requirements specified or shown **(no exceptions)**.

Contractor/Contractor's Representative *(Print Name)*

Signature



Submittal Transmittal

Project: DCH - Ambulatory Renewal

Date: 9/15/2021

Transmitted To:

Derek Shaw
Heapy
1400 W Dorthy Lane
Dayton, Ohio 45409
dashaw@heapy.com

Transmitted By:

Greg Myak
Danis Building Construction Company
One Children's Plaza
Dayton, Ohio 45404
Phone: 937-271-7086
richard.markwell@danis.com

Submittal No.	Submitted By:	Contact:
630-233616-001	Cinfab	Jacob Degen

Specification Section	Description	Status
233616	3rd Floor VAVs	OPEN

Submitted For	Copies
Approval	1

Please review & return 1 electronic copy of submittals in accordance with the contract specifications.

Danis Stamp:

REVIEWED by DANIS

Review does not relieve subcontractor or supplier from its obligation to perform its work complete, in strict accordance with the plans, specifications, subcontract, purchase order or other provisions of the contract documents. Review also does not relieve subcontractor or supplier from its responsibility for checking dimensions on the drawings and on the job or the proper matching and fitting of its work with contiguous work and the coordination its work with other work on the construction site.

Date: 9/15/2021 By Greg Myak

Submittal No. _____

A/E Stamps:

Comments:

Product Data:

Comments:

Project Name: DCH Ambulatory 3rd Floor VAVs

Project Location:

Engineer:

Contractor:

Contact:

Date: September 13, 2021

Submitted By: PRO FIT HVAC, LLCST. MARY'S, OH
UNITED STATES, 45885

Telephone: (419) 733 - 4733

Contact: Emily Klosterman

Nailor Single Duct VAV Units										Weight values are typical unit dry weights, and may not be specific for that product.										Corner weights must be measured in the field with all components attached.										For blank weight values, please contact factory.									
Pro DCH Ambulatory 3rd Floor VAVs										Date Created: 9/12/2021																													
Cus Cinfab										Date Due: 9/12/2021																													
Eng Heapy																																							
Item ID	Tag1	Model	ControlType	Heater Type	Quantity	Unit Size	Inlet Size	Outlet Size	Primary Max AF (cfm)	Primary Min AF (cfm)	Inlet SP (in wg)	Outlet SP (in wg)	Min Inlet SP (in wg)	MOP	MCA	Liner	Integral Attenuator	Rad NC	Dis NC	Rad NC OB	Dis NC OB	Rad Deducts	Dis Deducts	Rad SWLs	Dis SWLs	Rad SWLs Min	Dis SWLs Min	Ceiling Type	Calc Method	Hg AF (cfm)	KW	MBH (mbh)	Volt	Phase	Stages	Htr Amps	EAT (°F)	LAT (°F)	
1	63-3-01	D3ORE	D	E	1	10 X 10	14 X 12 1/2	770	510	3	0.25	0.01	15	6.8	FG1 - 1" (25) Steri-liner	No	25	29	4	3	18,19,20,26,31,36	29,30,41,51,52,39	60,55,51,47,41,39	74,70,68,65,60,58			Mineral Fiber	KW	510	4.5	15.4	480	3	1	5.41	55	82.7		
2	63-3-02	D3ORE	D	E	1	10 X 10	14 X 12 1/2	800	510	3	0.25	0.01	15	6.8	FG1 - 1" (25) Steri-liner	No	26	30	4	3	18,19,20,26,31,36	29,30,41,51,52,39	60,56,52,47,42,40	74,71,68,66,61,58			Mineral Fiber	KW	510	4.5	15.4	480	3	1	5.41	55	82.7		
3	63-3-03	D3ORE	D	E	1	12 X 12	18 X 12 1/2	900	290	3	0.25	0.01	15	6	FG1 - 1" (25) Steri-liner	No	25	25	3	3	18,19,20,26,31,36	29,30,41,51,52,39	57,56,50,48,42,41	72,67,67,65,61,59			Mineral Fiber	KW	450	4	13.6	480	3	1	4.81	55	83		
4	63-3-04	D3ORE	D	E	1	6 X 6	10 X 10	300	225	3	0.25	0.01	15	9	FG1 - 1" (25) Steri-liner	No	23	26	4	3	18,19,20,26,31,36	27,29,40,51,53,39	59,53,49,43,38,38	71,67,65,64,56,54	56,50,46,42,36,36	68,63,62,64,55,52	Mineral Fiber	KW	225	2	6.8	277	1	1	7.22	55	83		
5	63-3-05	D3ORE	D	E	1	8 X 8	12 X 12 1/2	400	125	3	0.25	0.01	15	9	FG1 - 1" (25) Steri-liner	No	24	28	4	3	18,19,20,26,31,36	27,29,40,51,53,39	58,54,50,40,39,38	70,68,67,63,58,55			Mineral Fiber	KW	200	2	6.8	277	1	1	7.22	55	86.4		
6	63-3-06	D3ORE	D	E	1	8 X 8	12 X 12 1/2	600	290	3	0.25	0.01	15	3.8	FG1 - 1" (25) Steri-liner	No	30	35	4	3	18,19,20,26,31,36	27,29,40,51,53,39	62,58,55,43,42,39	76,74,71,67,62,59			Mineral Fiber	KW	300	2.5	8.5	480	3	1	3.01	55	81.2		
7	63-3-07	D3ORE	D	E	1	6 X 6	10 X 10	360	360	3	0.25	0.01	15	4.5	FG1 - 1" (25) Steri-liner	No	25	30	2, 4	3	18,19,20,26,31,36	27,29,40,51,53,39	62,55,51,44,40,39	74,70,67,64,57,55	62,55,51,44,40,39	74,70,67,64,57,55	Mineral Fiber	KW	360	3	10.2	480	3	1	3.61	55	81.2		
8	63-3-08	D3ORE	D	E	1	6 X 6	10 X 10	350	70	3	0.25	0.01	15	6.8	FG1 - 1" (25) Steri-liner	No	25	29	4	3	18,19,20,26,31,36	27,29,40,51,53,39	61,55,51,44,40,39	73,69,67,64,57,55			Mineral Fiber	KW	175	4.5	5.1	277	1	1	5.42	55	82		
9	63-3-09	D3ORE	D	E	1	16 X 16	28 X 12 1/2	1860	450	3	0.25	0.01	20	18.8	FG1 - 1" (25) Steri-liner	No	34	28	3	3	18,19,20,26,31,36	29,30,41,51,52,39	62,63,56,51,45,42	72,69,68,66,64,62			Mineral Fiber	KW	1210	12.5	42.6	480	3	1	15.04	55	87.5		
10	63-3-10	D3ORE	D	E	1	8 X 8	12 X 12 1/2	530	170	3	0.25	0.01	15	3.8	FG1 - 1" (25) Steri-liner	No	28	33	4	3	18,19,20,26,31,36	27,29,40,51,53,39	61,56,53,42,41,39	74,72,69,65,61,57			Mineral Fiber	KW	265	2.5	8.5	480	3	1	3.01	55	84.7		
11	63-3-11	D3ORE	D	E	1	8 X 8	12 X 12 1/2	600	290	3	0.25	0.01	15	3.8	FG1 - 1" (25) Steri-liner	No	30	35	4	3	18,19,20,26,31,36	27,29,40,51,53,39	62,58,55,43,42,39	76,74,71,67,62,59			Mineral Fiber	KW	300	2.5	8.5	480	3	1	3.01	55	81.2		
12	63-3-12	D3ORE	D	E	1	8 X 8	12 X 12 1/2	600	225	3	0.25	0.01	15	3.8	FG1 - 1" (25) Steri-liner	No	30	35	4	3	18,19,20,26,31,36	27,29,40,51,53,39	62,58,55,43,42,39	76,74,71,67,62,59			Mineral Fiber	KW	300	2.5	8.5	480	3	1	3.01	55	81.2		
13	63-3-13	D3ORE	D	E	1	8 X 8	12 X 12 1/2	400	320	3	0.25	0.01	15	4.5	FG1 - 1" (25) Steri-liner	No	24	28	4	3	18,19,20,26,31,36	27,29,40,51,53,39	58,54,50,40,39,38	70,68,67,63,58,55			Mineral Fiber	KW	320	3	10.2	480	3	1	3.61	55	84.5		
14	63-3-14	D3ORE	D	E	1	8 X 8	12 X 12 1/2	425	425	3	0.25	0.01	15	5.3	FG1 - 1" (25) Steri-liner	No	25	29	4	3	18,19,20,26,31,36	27,29,40,51,53,39	59,54,51,40,39,38	71,69,67,63,58,55	59,54,51,40,39,38	71,69,67,63,58,55	Mineral Fiber	KW	425	3.5	11.9	480	3	1	4.21	55	80.9		
15	63-3-15	D3ORE	D	E	1	6 X 6	10 X 10	200	70	3	0.25	0.01	15	4.5	FG1 - 1" (25) Steri-liner	No	20	24	4	2	18,19,20,26,31,36	24,28,39,53,59,40	54,48,46,41,36,36	67,62,61,64,55,51			Mineral Fiber	KW	100	1	3.4	277	1	1	3.61	55	86.4		
16	63-3-16	D3ORE	D	E	1	6 X 6	10 X 10	350	350	3	0.25	0.01	15	4.5	FG1 - 1" (25) Steri-liner	No	25	29	4	3	18,19,20,26,31,36	27,29,40,51,53,39	61,55,51,44,40,39	73,69,67,64,57,55	61,55,51,44,40,39	73,69,67,64,57,55	Mineral Fiber	KW	350	3	10.2	480	3	1	3.61	55	82		
17	63-3-17	D3ORE	D	E	1	8 X 8	12 X 12 1/2	400	320	3	0.25	0.01	15	4.5	FG1 - 1" (25) Steri-liner	No	24	28	4	3	18,19,20,26,31,36	27,29,40,51,53,39	58,54,50,40,39,38	70,68,67,63,58,55			Mineral Fiber	KW	320	3	10.2	480	3	1	3.61	55	84.5		
18	63-3-18	D3ORE	D	E	1	10 X 10	14 X 12 1/2	655	655	3	0.25	0.01	15	8.3	FG1 - 1" (25) Steri-liner	No	23	28	4	3	18,19,20,26,31,36	27,29,40,51,53,39	58,53,49,45,40,38	71,68,66,64,59,56	58,53,49,45,40,38	71,68,66,64,59,56	Mineral Fiber	KW	655	5.5	18.8	480	3	1	6.62	55	81.4		
19	63-3-19	D3ORE	D	E	1	6 X 6	10 X 10	200	190	3	0.25	0.01	15	9	FG1 - 1" (25) Steri-liner	No	20	24	4	2	18,19,20,26,31,36	24,28,39,53,59,40	54,48,46,41,36,36	67,62,61,64,55,51	54,48,45,42,36,36	66,61,61,64,55,51	Mineral Fiber	KW	190	2	6.8	277	1	1	7.22	55	88.1		
20	63-3-20	D3ORE	D	E	1	10 X 10	14 X 12 1/2	805	805	3	0.25	0.01	15	11.3	FG1 - 1" (25) Steri-liner	No	26	30	4	3	18,19,20,26,31,36	29,30,41,51,52,39	60,56,52,47,42,40	74,71,68,66,61,58	60,56,52,47,42,40	74,71,68,66,61,58	Mineral Fiber	KW	805	7.5	25.6	480	3	1	9.02	55	84.3		
21	63-3-21	D3ORE	D	E	1	8 X 8	12 X 12 1/2	550	125	3	0.25	0.01	15	4.5	FG1 - 1" (25) Steri-liner	No	29	34	4	3	18,19,20,26,31,36	27,29,40,51,53,39	62,57,54,42,41,39	75,73,70,66,61,58			Mineral Fiber	KW	330	3	10.2	480	3	1	3.61	55	83.6		
22	63-3-22	D3ORE	D	E	1	8 X 8	12 X 12 1/2	600	125	3	0.25	0.01	15	4.5	FG1 - 1" (25) Steri-liner	No	30	35	4	3	18,19,20,26,31,36	27,29,40,51,53,39	62,58,55,43,42,39	76,74,71,67,62,59			Mineral Fiber	KW	360	3	10.2	480	3	1	3.61	55	81.2		
23	63-3-23	D3ORE	D	E	1	10 X 10	14 X 12 1/2	825	225	3	0.25	0.01	15	6.8	FG1 - 1" (25) Steri-liner	No	26	30	4	3	18,19,20,26,31,36	29,30,41,51,52,39	60,56,52,48,42,40	75,71,68,66,61,59			Mineral Fiber	KW	495	4.5	15.4	480	3	1	5.41	55	83.6		
24	63-3-24	D3ORE	D	E	1	8 X 8	12 X 12 1/2	600	125	3	0.25	0.01	15	4.5	FG1 - 1" (25) Steri-liner	No	30	35	4	3	18,19,20,26,31,36	27,29,40,51,53,39	62,58,55,43,42,39	76,74,71,67,62,59			Mineral Fiber	KW	360	3	10.2	480	3	1	3.61	55	81.2		
25	63-3-25	D3ORE	D	E	1	8 X 8	12 X 12 1/2	365	125	3	0.25	0	15	9	FG1 - 1" (25) Steri-liner	No	24	28	4	3	18,19,20,26,31,36	27,29,40,51,53,39	62,58,55,43,42,39	76,74,71,67,62,59			Mineral Fiber	KW	220	2	6.8	277	1	1	7.22	55	83.6		
26	63-3-26	D3ORE	D	E	1	8 X 8	12 X 12 1/2	400	320	3	0.25	0.01	15	4.5	FG1 - 1" (25) Steri-liner	No	24	28	4	3	18,19,20,26,31,36	27,29,40,51,53,39	58,54,50,40,39,38	70,68,67,63,58,55			Mineral Fiber	KW	320	3	10.2	480	3	1	3.61	55	84.5		
27	63-3-27	D3ORE	D	E	1	8 X 8	12 X 12 1/2	485	485	3	0.25	0.01	15	6	FG1 - 1" (25) Steri-liner	No	26	31	4	3	18,19,20,26,31,36	27,29,40,51,53,39	60,55,52,41,40,38	73,71,68,65,60,57	60,55,52,41,40,38	73,71,68,65,60,57	Mineral Fiber	KW	485	4	13.6	480	3	1	4.81	55	80.9		
28	63-3-28	D3ORE	D	E	1	6 X 6	10 X 10	295	75	3	0.25	0.01	15	6.8	FG1 - 1" (25) Steri-liner	No	23	29	4	2	18,19,20,26,31,36	24,28,39,53,59,40	59,53,49,43,38,38	71,67,65,64,56,53			Mineral Fiber	KW	150	1.5	5.1	277	1	1	5.42	55	86.4		
29	63-3-29	D3ORE	D	E	1	6 X 6	10 X 10	250	75	3	0.25	0.01	15	4.5	FG1 - 1" (25) Steri-liner	No	21	26	4	2	18,19,20,26,31,36	24,28,39,53,59,40	57,51,47,42,37,37	69,64,63,64,55,52			Mineral Fiber	KW	125	1	3.4	277	1	1	3.61	55	80.2		
30	64-3-01	D3ORE	D	E	1	6 X 6	10 X 10	310	65	3	0.25	0.01	15	9	FG1 - 1" (25) Steri-liner	No	23	26	4	2, 3	18,19,20,26,31,36	27,29,40,51,53,39	59,53,49,43,39,38	72,67,65,64,56,54			Mineral Fiber	KW	190	2	6.8	277	1	1	7.22	55	88.1		
31	64-3-02	D3ORE	D	E	1	12 X 12	18 X 12 1/2	1055	300	3	0.25	0.01	15	7.5	FG1 - 1" (25) Steri-liner	No	28	29	3	3	18,19,20,26,31,36	29,30,41,51,52,39	59,58,52,50,43,42	74,70,69,67,63,60			Mineral Fiber	KW	530	5	17.1	480	3	1	6.01	55	84.7		
32	64-3-03	D3ORE	D	E	1	6 X 6	10 X 10	220	85	3	0.25	0.01	15	9	FG1 - 1" (25) Steri-liner	No	20	25	4	2	18,19,20,26,31,36	24,28,39,53,59,40	55,49,46,42,36,36	68,63,62,64,55,52			Mineral Fiber	KW	155	2	6.8	277	1	1	7.22	55	95.6		
33	64-3-04	D3ORE	D	E	1	10 X 10	14 X 12 1/2	765	335	3	0.25	0.01	15	9.8	FG1 -																								

PROJECT SCHEDULE**DCH Ambulatory 3rd Floor VAVs****Terminal Units**

Item	Qty	Model	Tag 1	Unit	Max Cooling CFM	Min Cooling CFM	Aux. Min CFM	kW
1	1	D30RE	63-3-01	10	770	510	510	4.5
			10- NB- OR- QD2- FG1- FN- FS- 480/3- SCR- BB					
2	1	D30RE	63-3-02	10	800	510	510	4.5
			10- NB- OR- QD2- FG1- FN- FS- 480/3- SCR- BB					
3	1	D30RE	63-3-03	12	900	290	450	4.0
			12- NB- OR- QD2- FG1- FN- FS- 480/3- SCR- BB					
4	1	D30RE	63-3-04	06	300	225	225	2.0
			06- NB- OR- QD- FG1- FN- FS- 277/1- SCR- BB					
5	1	D30RE	63-3-05	08	400	125	200	2.0
			08- NB- OR- QD- FG1- FN- FS- 277/1- SCR- BB					
6	1	D30RE	63-3-06	08	600	290	300	2.5
			08- NB- OR- QD2- FG1- FN- FS- 480/3- SCR- BB					
7	1	D30RE	63-3-07	06	360	360	360	3.0
			06- NB- OR- QD2- FG1- FN- FS- 480/3- SCR- BB					
8	1	D30RE	63-3-08	06	350	70	175	1.5
			06- NB- OR- QD- FG1- FN- FS- 277/1- SCR- BB					
9	1	D30RE	63-3-09	16	1860	450	1210	12.5
			16- NB- OR- QD2- FG1- FN- FS- 480/3- SCR- BB					
10	1	D30RE	63-3-10	08	530	170	265	2.5
			08- NB- OR- QD2- FG1- FN- FS- 480/3- SCR- BB					
11	1	D30RE	63-3-11	08	600	290	300	2.5
			08- NB- OR- QD2- FG1- FN- FS- 480/3- SCR- BB					
12	1	D30RE	63-3-12	08	600	225	300	2.5
			08- NB- OR- QD2- FG1- FN- FS- 480/3- SCR- BB					
13	1	D30RE	63-3-13	08	400	320	320	3.0
			08- NB- OR- QD2- FG1- FN- FS- 480/3- SCR- BB					
14	1	D30RE	63-3-14	08	425	425	425	3.5
			08- NB- OR- QD2- FG1- FN- FS- 480/3- SCR- BB					
15	1	D30RE	63-3-15	06	200	70	100	1.0
			06- NB- OR- QD- FG1- FN- FS- 277/1- SCR- BB					
16	1	D30RE	63-3-16	06	350	350	350	3.0
			06- NB- OR- QD2- FG1- FN- FS- 480/3- SCR- BB					

Dimensions are in inches (mm)

Nailor Industries Inc. reserves the right to change any information concerning product or pricing without notice.

PROJECT SCHEDULE**DCH Ambulatory 3rd Floor VAVs****Terminal Units**

Item	Qty	Model	Tag 1	Unit	Max Cooling CFM	Min Cooling CFM	Aux. Min CFM	kW
17	1	D30RE	63-3-17	08	400	320	320	3.0
			08- NB- OR- QD2- FG1- FN- FS- 480/3- SCR- BB					
18	1	D30RE	63-3-18	10	655	655	655	5.5
			10- NB- OR- QD2- FG1- FN- FS- 480/3- SCR- BB					
19	1	D30RE	63-3-19	06	200	190	190	2.0
			06- NB- OR- QD- FG1- FN- FS- 277/1- SCR- BB					
20	1	D30RE	63-3-20	10	805	805	805	7.5
			10- NB- OR- QD2- FG1- FN- FS- 480/3- SCR- BB					
21	1	D30RE	63-3-21	08	550	125	330	3.0
			08- NB- OR- QD2- FG1- FN- FS- 480/3- SCR- BB					
22	1	D30RE	63-3-22	08	600	125	360	3.0
			08- NB- OR- QD2- FG1- FN- FS- 480/3- SCR- BB					
23	1	D30RE	63-3-23	10	825	225	495	4.5
			10- NB- OR- QD2- FG1- FN- FS- 480/3- SCR- BB					
24	1	D30RE	63-3-24	08	600	125	360	3.0
			08- NB- OR- QD2- FG1- FN- FS- 480/3- SCR- BB					
25	1	D30RE	63-3-25	08	365	125	220	2.0
			08- NB- OR- QD- FG1- FN- FS- 277/1- SCR- BB					
26	1	D30RE	63-3-26	08	400	320	320	3.0
			08- NB- OR- QD2- FG1- FN- FS- 480/3- SCR- BB					
27	1	D30RE	63-3-27	08	485	485	485	4.0
			08- NB- OR- QD2- FG1- FN- FS- 480/3- SCR- BB					
28	1	D30RE	63-3-28	06	295	75	150	1.5
			06- NB- OR- QD- FG1- FN- FS- 277/1- SCR- BB					
29	1	D30RE	63-3-29	06	250	75	125	1.0
			06- NB- OR- QD- FG1- FN- FS- 277/1- SCR- BB					
30	1	D30RE	64-3-01	06	310	65	190	2.0
			06- NB- OR- QD- FG1- FN- FS- 277/1- SCR- BB					
31	1	D30RE	64-3-02	12	1055	300	530	5.0
			12- NB- OR- QD2- FG1- FN- FS- 480/3- SCR- BB					

Dimensions are in inches (mm)

Nailor Industries Inc. reserves the right to change any information concerning product or pricing without notice.

PROJECT SCHEDULE**DCH Ambulatory 3rd Floor VAVs****Terminal Units**

Item	Qty	Model	Tag 1	Unit	Max Cooling CFM	Min Cooling CFM	Aux. Min CFM	kW
32	1	D30RE	64-3-03	06	220	85	155	2.0
			06- NB- OR- QD- FG1- FN- FS- 277/1- SCR- BB					
33	1	D30RE	64-3-04	10	765	335	575	6.5
			10- NB- OR- QD2- FG1- FN- FS- 480/3- SCR- BB					
34	1	D30RE	64-3-05	14	1740	665	1135	12.0
			14- NB- OR- QD2- FG1- FN- FS- 480/3- SCR- BB					
35	1	D30RE	64-3-06	24	2250	1080	1465	14.5
			24- NB- OR- QD2- FG1- FN- FS- 480/3- SCR- BB					
36	1	D30RE	64-3-07	08	515	125	260	2.5
			08- NB- OR- QD2- FG1- FN- FS- 480/3- SCR- BB					
37	1	D30RE	64-3-08	16	1970	1970	1970	16.0
			16- NB- OR- QD2- FG1- FN- FS- 480/3- SCR- BB					
38	1	D30RE	64-3-09	06	360	205	270	3.0
			06- NB- OR- QD2- FG1- FN- FS- 480/3- SCR- BB					
39	1	D30RE	64-3-10	08	465	465	465	4.0
			08- NB- OR- QD2- FG1- FN- FS- 480/3- SCR- BB					
40	1	D30RE	64-3-11	06	200	200	200	2.0
			06- NB- OR- QD- FG1- FN- FS- 277/1- SCR- BB					
41	1	D30RE	64-3-12	08	385	375	375	3.0
			08- NB- OR- QD2- FG1- FN- FS- 480/3- SCR- BB					
42	1	D30RE	64-3-13	06	200	200	200	2.0
			06- NB- OR- QD- FG1- FN- FS- 277/1- SCR- BB					
43	1	D30RE	64-3-14	08	565	565	565	5.0
			08- NB- OR- QD2- FG1- FN- FS- 480/3- SCR- BB					
44	1	D30RE	64-3-15	06	200	200	200	2.0
			06- NB- OR- QD- FG1- FN- FS- 277/1- SCR- BB					
45	1	D30RE	64-3-16	06	200	80	120	1.5
			06- NB- OR- QD- FG1- FN- FS- 277/1- SCR- BB					
46	1	D30RE	64-3-17	12	1050	1050	1050	8.5
			12- NB- OR- QD2- FG1- FN- FS- 480/3- SCR- BB					

Dimensions are in inches (mm)

Nailor Industries Inc. reserves the right to change any information concerning product or pricing without notice.

PROJECT SCHEDULE**DCH Ambulatory 3rd Floor VAVs****Terminal Units**



Item	Qty	Model	Tag 1	Unit	Max	Min	Aux.	kW
		Option	Codes	Size	Cooling	Cooling	Min	
					CFM	CFM	CFM	
47	1	D30RE	64-3-18	16	2000	450	1000	9.5
		16- NB- OR- QD2- FG1- FN- FS- 480/3- SCR- BB						
48	1	D30RE	64-3-19	06	200	150	150	1.5
		06- NB- OR- QD- FG1- FN- FS- 277/1- SCR- BB						
49	1	D30RE	64-3-20	06	300	225	225	2.0
		06- NB- OR- QD- FG1- FN- FS- 277/1- SCR- BB						

Dimensions are in inches (mm)

Nailor Industries Inc. reserves the right to change any information concerning product or pricing without notice.

Items: 1, 2, 6, 10, 11, 12, 13, 14, 17, 18, 20, 21, 22, 23, 24, 26, 27, 33, 36, 39, 41, 43; Tags: 63-3-01; 63-3-02; 63-3-06; 63-3-10; 63-3-11; 63-3-12; 63-3-13; 63-3-14; 63-3-17; 63-3-18; 63-3-20; 63-3-21; 63-3-22; 63-3-23; 63-3-24; 63-3-26; 63-3-27; 64-3-04; 64-3-07; 64-3-10; 64-3-12; 64-3-14

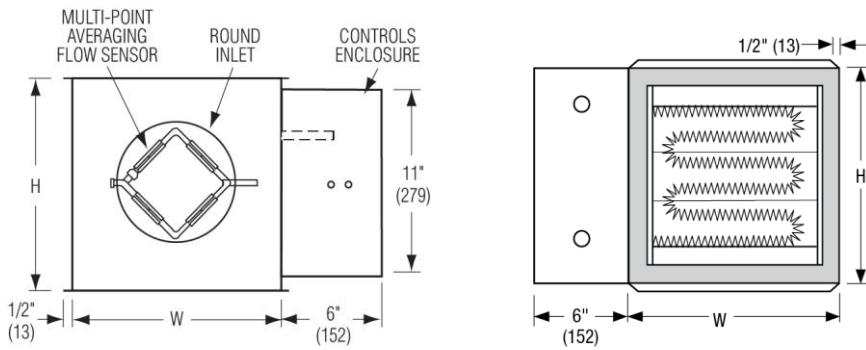
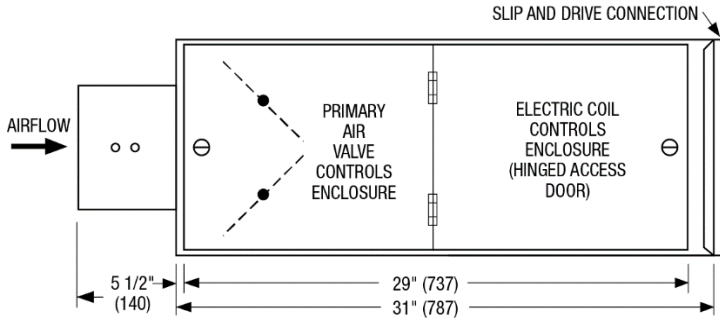

Right-hand controls location shown
 *Controls Enclosure optional with field mounted controls

DIMENSIONAL DATA

Unit Size	Min - Max Airflow Range cfm (l/s)	Width (W)	Height (H)	Inlet Size
8	125 – 1100 (59 – 519)	12 (305)	12 1/2 (318)	7 7/8 (200) Round
10	215 – 1840 (101 – 868)	14 (356)	12 1/2 (318)	9 7/8 (251) Round

Minimum flows are based upon 0.02" w.g. (5 Pa) differential pressure from flow sensor. The maximum flow rate represents the diamond flow sensor's differential pressure reading at 1.5" w.g. (373 Pa).

FEATURES

- 16 ga. (1.61) corrosion-resistant steel inclined opposed blade damper with extruded PVC seals. 45° rotation, CW to close. Tight close-off. Damper leakage is less than 2% of the terminal rated airflow at 3" w.g. (750 Pa)
- 1/2" (13) dia. plated steel drive shaft. An indicator mark on the end of the shaft shows damper position
- Multi-point averaging Diamond Flow Sensor. Aluminum construction. Supplied with balancing tees
- Electric Coil is mounted in an integral attenuator section

Project: DCH Ambulatory 3rd Floor VAVs
Engineer:
Contractor:

Date: 9/13/2021
Version No: 3.84.02 Rev.11

Dimensions are in inches (mm)

- Class A 80/20 Ni/Cr wire
- High performance ceramic insulators
- 24Vac Class II control transformer
- Hinged door control enclosure
- Positive pressure air proving switch
- Primary auto-reset high limit thermal cut-out (one per coil in control circuit)
- Secondary manual reset high limit thermal cut-outs (one per element)
- Magnetic contactor per stage
- Damper Actuator: Not Provided
- NB - Controls: By Others (Field Mounted)
- OR - 22 ga. (0.86) zinc coated steel casing, mechanically sealed, low leakage construction, right hand (determined when looking in the direction of airflow)
- QD2 - Transformer: 480/24V
- **FG1 - 1" (25) Steri-Liner**
- FN - Full NEMA 1 type 24V Controls Enclosure
- FS - Hanger Brackets
- 4803 - Electric Coil: 480 volt/3 phase/3-wire
- SCR - SCR with 0-10 Vdc Control
- BB - Door-Interlocking disconnect switch

FG1 - Steri-Liner

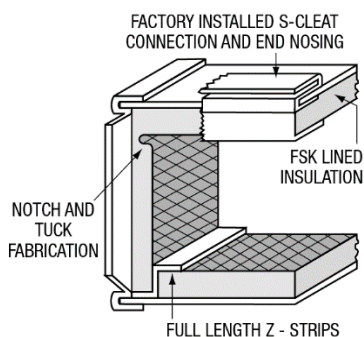

- 1" (25) thick, rigid fiberglass with a fire resistant reinforced aluminum FSK (foil-scrim-kraft) facing
- Meets requirements:
- UL 181 & 723
 - NFPA 90A & 90B
 - ASTM E 84, C 665, C 1071, C 1338, G21 & G22

OR - Top View Orientation- Controls Location

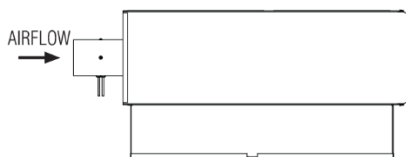

Right Hand Controls Location

Project: DCH Ambulatory 3rd Floor VAVs

Date: 9/13/2021

Engineer:

Version No: 3.84.02 Rev.11

Contractor:

Dimensions are in inches (mm)

Nailor Industries Inc. reserves the right to change any information concerning product or pricing without notice.

Items: 3, 9, 31, 34, 37, 46, 47; Tags: 63-3-03; 63-3-09; 64-3-02; 64-3-05; 64-3-08; 64-3-17; 64-3-18

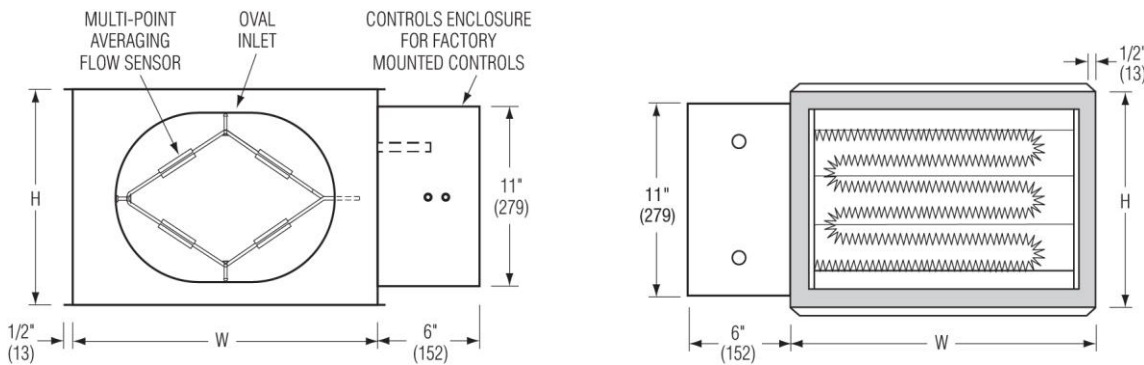
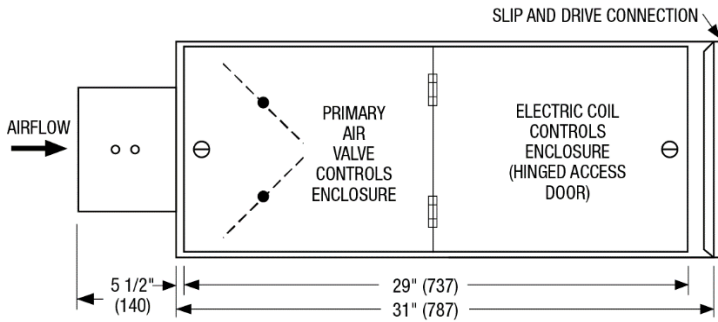

DIMENSIONAL DATA

Unit Size	Min - Max Airflow Range cfm (l/s)	Width (W)	Height (H)	Inlet Size
12	290 – 2500 (137 – 1180)	18 (457)	12 1/2 (318)	12 15/16 x 9 13/16 (329 x 249) Oval
14	360 – 3125 (170 – 1475)	24 (610)	12 1/2 (318)	16 1/16 x 9 13/16 (408 x 249) Oval
16	430 – 3725 (203 – 1758)	28 (711)	12 1/2 (318)	19 3/16 x 9 13/16 (487 x 249) Oval

Minimum flows are based upon 0.02" w.g. (5 Pa) differential pressure from flow sensor. The maximum flow rate represents the diamond flow sensor's differential pressure reading at 1.5" w.g. (373 Pa).

FEATURES

- 16 ga. (1.61) corrosion-resistant steel inclined opposed blade damper with extruded PVC seals. 45° rotation, CW to close. Tight close-off. Damper leakage is less than 2% of the terminal rated airflow at 3" w.g. (750 Pa)
- 1/2" (13) dia. plated steel drive shaft. An indicator mark on the end of the shaft shows damper position
- Multi-point averaging Diamond Flow Sensor. Aluminum construction. Supplied with balancing tees
- Electric Coil is mounted in an integral attenuator section
- Class A 80/20 Ni/Cr wire
- High performance ceramic insulators
- 24Vac Class II control transformer

Project: DCH Ambulatory 3rd Floor VAVs
Engineer:
Contractor:

Date: 9/13/2021
Version No: 3.84.02 Rev.11

Dimensions are in inches (mm)

- Hinged door control enclosure
- Positive pressure air proving switch
- Primary auto-reset high limit thermal cut-out (one per coil in control circuit)
- Secondary manual reset high limit thermal cut-outs (one per element)
- Magnetic contactor per stage
- Damper Actuator: Not Provided
- NB - Controls: By Others (Field Mounted)
- OR - 22 ga. (0.86) zinc coated steel casing, mechanically sealed, low leakage construction, right hand (determined when looking in the direction of airflow)
- QD2 - Transformer: 480/24V
- FG1 - 1" (25) Steri-Liner
- FN - Full NEMA 1 type 24V Controls Enclosure
- FS - Hanger Brackets
- 4803 - Electric Coil: 480 volt/3 phase/3-wire
- SCR - SCR with 0-10 Vdc Control
- BB - Door-Interlocking disconnect switch

FG1 - Steri-Liner

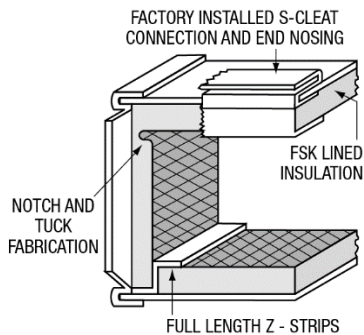

- 1" (25) thick, rigid fiberglass with a fire resistant reinforced aluminum FSK (foil-scrim-kraft) facing
- Meets requirements:
- UL 181 & 723
 - NFPA 90A & 90B
 - ASTM E 84, C 665, C 1071, C 1338, G21 & G22

OR - Top View Orientation- Controls Location

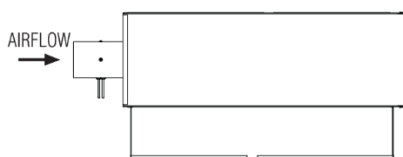

Right Hand Controls Location

Project: DCH Ambulatory 3rd Floor VAVs

Date: 9/13/2021

Engineer:

Version No: 3.84.02 Rev.11

Contractor:

Dimensions are in inches (mm)

Nailor Industries Inc. reserves the right to change any information concerning product or pricing without notice.

Items: 4, 8, 15, 19, 28, 29, 30, 32, 40, 42, 44, 45, 48, 49; Tags: 63-3-04; 63-3-08; 63-3-15; 63-3-19; 63-3-28; 63-3-29; 64-3-01; 64-3-03; 64-3-11; 64-3-13; 64-3-15; 64-3-16; 64-3-19; 64-3-20

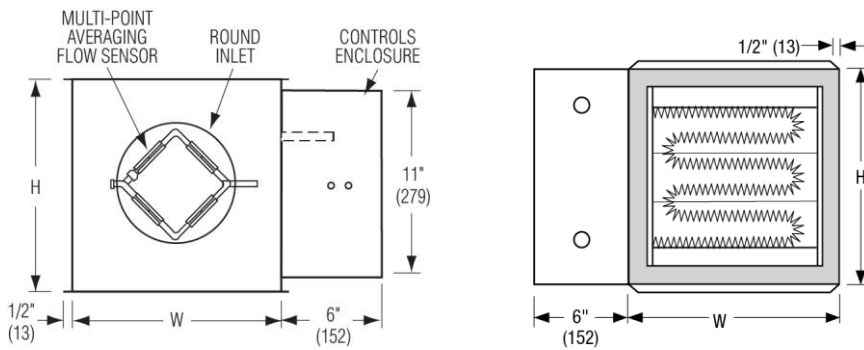
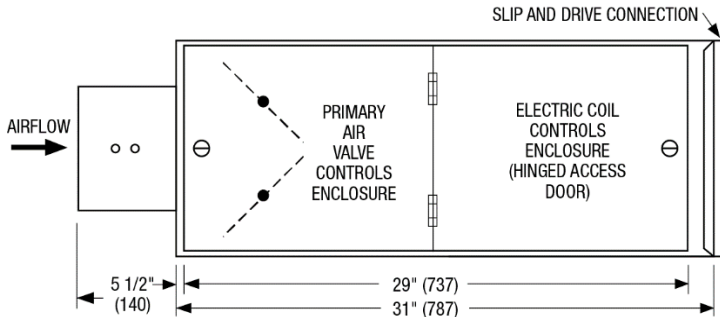

Right-hand controls location shown

*Controls Enclosure optional with field mounted controls

DIMENSIONAL DATA

Unit Size	Min - Max Airflow Range cfm (l/s)	Width (W)	Height (H)	Inlet Size
6	65 – 550 (31 – 260)	10 (254)	10 (254)	5 7/8 (149) Round

Minimum flows are based upon 0.02" w.g. (5 Pa) differential pressure from flow sensor. The maximum flow rate represents the diamond flow sensor's differential pressure reading at 1.5" w.g. (373 Pa).

FEATURES

- 16 ga. (1.61) corrosion-resistant steel inclined single blade damper with extruded PVC seals. 45° rotation, CW to close. Tight close-off. Damper leakage is less than 2% of the terminal rated airflow at 3" w.g. (750 Pa)
- 1/2" (13) dia. plated steel drive shaft. An indicator mark on the end of the shaft shows damper position
- Multi-point averaging Diamond Flow Sensor. Aluminum construction. Supplied with balancing tees
- Electric Coil is mounted in an integral attenuator section
- Class A 80/20 Ni/Cr wire
- High performance ceramic insulators
- 24Vac Class II control transformer

Project: DCH Ambulatory 3rd Floor VAVs
Engineer:
Contractor:

Date: 9/13/2021
Version No: 3.84.02 Rev.11

Dimensions are in inches (mm)

Nailor Industries Inc. reserves the right to change any information concerning product or pricing without notice.

- Hinged door control enclosure
- Positive pressure air proving switch
- Primary auto-reset high limit thermal cut-out (one per coil in control circuit)
- Secondary manual reset high limit thermal cut-outs (one per element)
- Magnetic contactor per stage
- Damper Actuator: Not Provided
- NB - Controls: By Others (Field Mounted)
- OR - 22 ga. (0.86) zinc coated steel casing, mechanically sealed, low leakage construction, right hand (determined when looking in the direction of airflow)
- QD - Transformer: 277/24V
- FG1 - 1" (25) Steri-Liner
- FN - Full NEMA 1 type 24V Controls Enclosure
- FS - Hanger Brackets
- 2771 - Electric Coil: 277 volt/1 phase/2-wire
- SCR - SCR with 0-10 Vdc Control
- BB - Door-Interlocking disconnect switch

FG1 - Steri-Liner

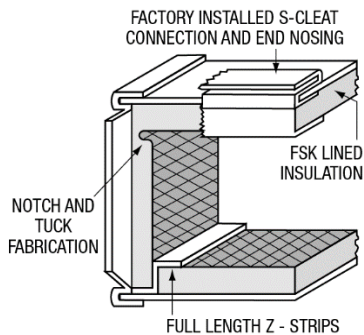

- 1" (25) thick, rigid fiberglass with a fire resistant reinforced aluminum FSK (foil-scrim-kraft) facing
- Meets requirements:
 - UL 181 & 723
 - NFPA 90A & 90B
 - ASTM E 84, C 665, C 1071, C 1338, G21 & G22

OR - Top View Orientation- Controls Location

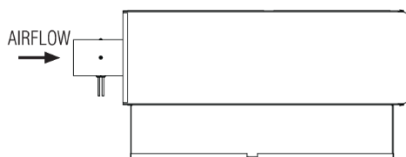

Right Hand Controls Location

Items: 5, 25; Tags: 63-3-05; 63-3-25

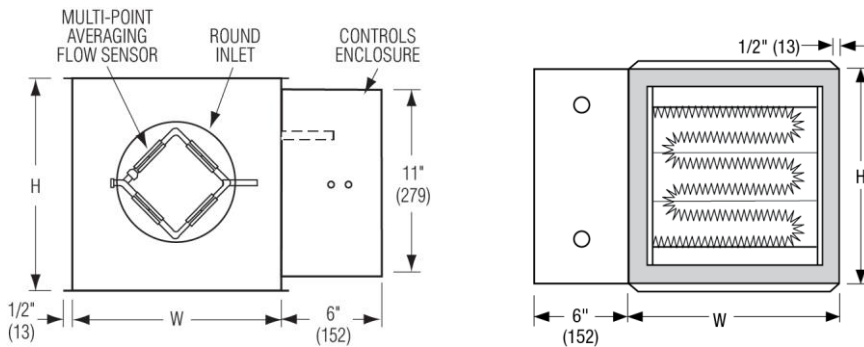
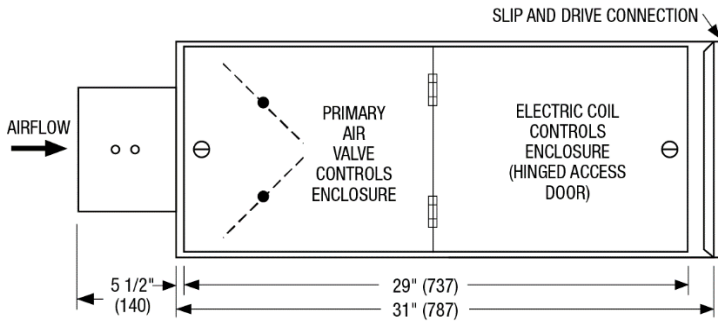

Right-hand controls location shown

*Controls Enclosure optional with field mounted controls

DIMENSIONAL DATA

Unit Size	Min - Max Airflow Range cfm (l/s)	Width (W)	Height (H)	Inlet Size
8	125 – 1100 (59 – 519)	12 (305)	12 1/2 (318)	7 7/8 (200) Round

Minimum flows are based upon 0.02" w.g. (5 Pa) differential pressure from flow sensor. The maximum flow rate represents the diamond flow sensor's differential pressure reading at 1.5" w.g. (373 Pa).

FEATURES

- 16 ga. (1.61) corrosion-resistant steel inclined opposed blade damper with extruded PVC seals. 45° rotation, CW to close. Tight close-off. Damper leakage is less than 2% of the terminal rated airflow at 3" w.g. (750 Pa)
- 1/2" (13) dia. plated steel drive shaft. An indicator mark on the end of the shaft shows damper position
- Multi-point averaging Diamond Flow Sensor. Aluminum construction. Supplied with balancing tees
- Electric Coil is mounted in an integral attenuator section
- Class A 80/20 Ni/Cr wire
- High performance ceramic insulators
- 24Vac Class II control transformer
- Hinged door control enclosure

Project: DCH Ambulatory 3rd Floor VAVs

Date: 9/13/2021

Engineer:

Version No: 3.84.02 Rev.11

Contractor:

Dimensions are in inches (mm)

Nailor Industries Inc. reserves the right to change any information concerning product or pricing without notice.

- Positive pressure air proving switch
- Primary auto-reset high limit thermal cut-out (one per coil in control circuit)
- Secondary manual reset high limit thermal cut-outs (one per element)
- Magnetic contactor per stage
- Damper Actuator: Not Provided
- NB - Controls: By Others (Field Mounted)
- OR - 22 ga. (0.86) zinc coated steel casing, mechanically sealed, low leakage construction, right hand (determined when looking in the direction of airflow)
- QD - Transformer: 277/24V
- FG1 - 1" (25) Steri-Liner
- FN - Full NEMA 1 type 24V Controls Enclosure
- FS - Hanger Brackets
- 2771 - Electric Coil: 277 volt/1 phase/2-wire
- SCR - SCR with 0-10 Vdc Control
- BB - Door-Interlocking disconnect switch

FG1 - Steri-Liner

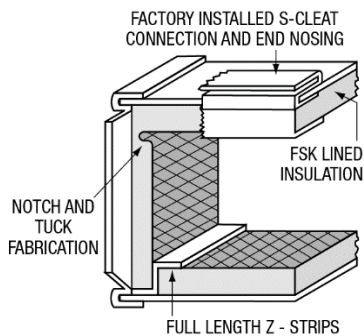

- 1" (25) thick, rigid fiberglass with a fire resistant reinforced aluminum FSK (foil-scrim-kraft) facing
- Meets requirements:
- UL 181 & 723
 - NFPA 90A & 90B
 - ASTM E 84, C 665, C 1071, C 1338, G21 & G22

OR - Top View Orientation- Controls Location

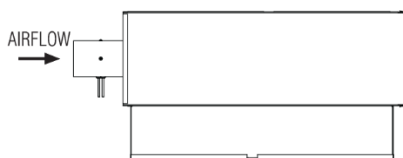

Right Hand Controls Location

Project: DCH Ambulatory 3rd Floor VAVs

Date: 9/13/2021

Engineer:

Version No: 3.84.02 Rev.11

Contractor:

Dimensions are in inches (mm)

Nailor Industries Inc. reserves the right to change any information concerning product or pricing without notice.

Items: 7, 16, 38; Tags: 63-3-07; 63-3-16; 64-3-09

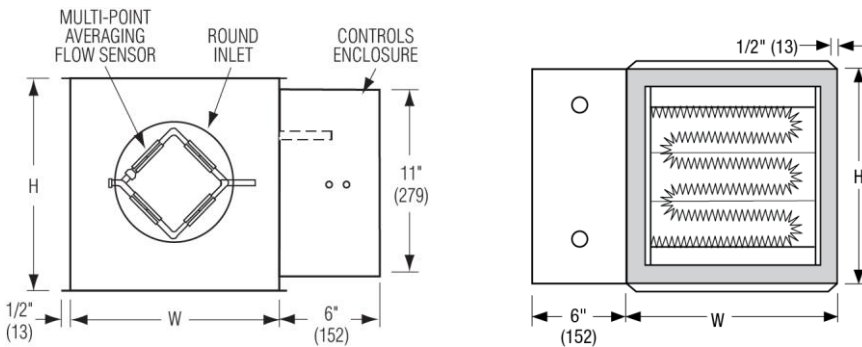
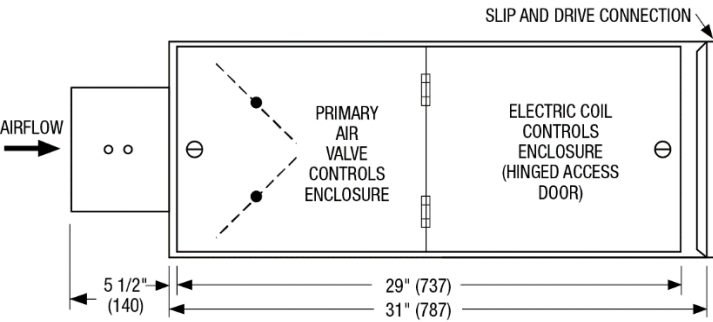

Right-hand controls location shown

*Controls Enclosure optional with field mounted controls

DIMENSIONAL DATA

Unit Size	Min - Max Airflow Range cfm (l/s)	Width (W)	Height (H)	Inlet Size
6	65 – 550 (31 – 260)	10 (254)	10 (254)	5 7/8 (149) Round

Minimum flows are based upon 0.02" w.g. (5 Pa) differential pressure from flow sensor. The maximum flow rate represents the diamond flow sensor's differential pressure reading at 1.5" w.g. (373 Pa).

FEATURES

- 16 ga. (1.61) corrosion-resistant steel inclined single blade damper with extruded PVC seals. 45° rotation, CW to close. Tight close-off. Damper leakage is less than 2% of the terminal rated airflow at 3" w.g. (750 Pa)
- 1/2" (13) dia. plated steel drive shaft. An indicator mark on the end of the shaft shows damper position
- Multi-point averaging Diamond Flow Sensor. Aluminum construction. Supplied with balancing tees
- Electric Coil is mounted in an integral attenuator section
- Class A 80/20 Ni/Cr wire
- High performance ceramic insulators
- 24Vac Class II control transformer
- Hinged door control enclosure

Project: DCH Ambulatory 3rd Floor VAVs
Engineer:
Contractor:

Date: 9/13/2021
Version No: 3.84.02 Rev.11

Dimensions are in inches (mm)

Nailor Industries Inc. reserves the right to change any information concerning product or pricing without notice.

- Positive pressure air proving switch
- Primary auto-reset high limit thermal cut-out (one per coil in control circuit)
- Secondary manual reset high limit thermal cut-outs (one per element)
- Magnetic contactor per stage
- Damper Actuator: Not Provided
- NB - Controls: By Others (Field Mounted)
- OR - 22 ga. (0.86) zinc coated steel casing, mechanically sealed, low leakage construction, right hand (determined when looking in the direction of airflow)
- QD2 - Transformer: 480/24V
- FG1 - 1" (25) Steri-Liner
- FN - Full NEMA 1 type 24V Controls Enclosure
- FS - Hanger Brackets
- 4803 - Electric Coil: 480 volt/3 phase/3-wire
- SCR - SCR with 0-10 Vdc Control
- BB - Door-Interlocking disconnect switch

FG1 - Steri-Liner

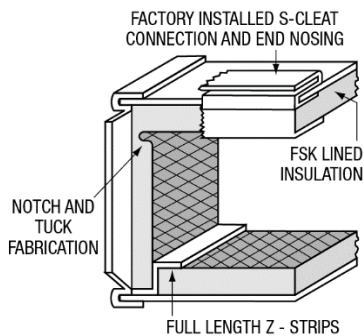

- 1" (25) thick, rigid fiberglass with a fire resistant reinforced aluminum FSK (foil-scrim-kraft) facing
- Meets requirements:
- UL 181 & 723
 - NFPA 90A & 90B
 - ASTM E 84, C 665, C 1071, C 1338, G21 & G22

OR - Top View Orientation- Controls Location

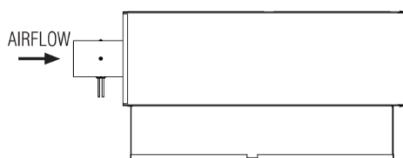

Right Hand Controls Location

Project: DCH Ambulatory 3rd Floor VAVs

Date: 9/13/2021

Engineer:

Version No: 3.84.02 Rev.11

Contractor:

Dimensions are in inches (mm)

Nailor Industries Inc. reserves the right to change any information concerning product or pricing without notice.

Item: 35; Tags: 64-3-06

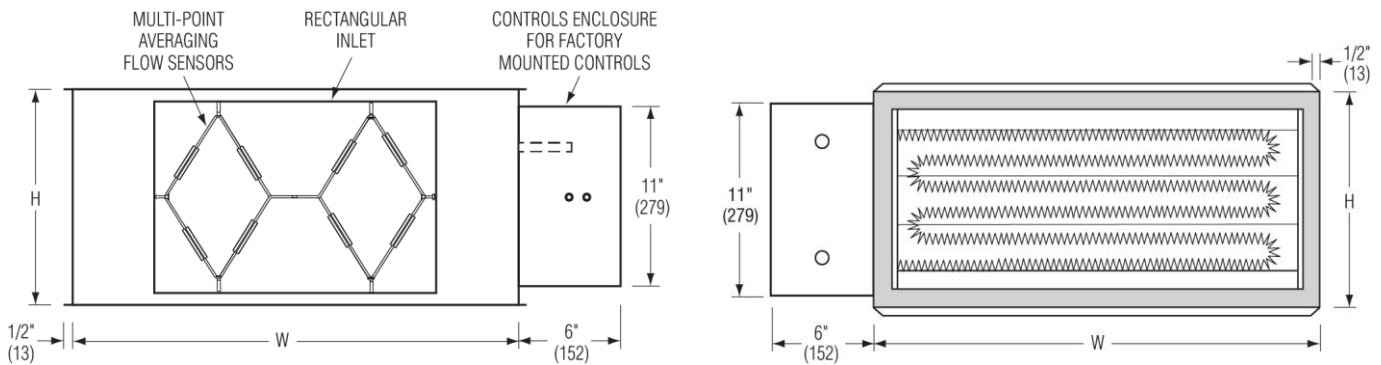
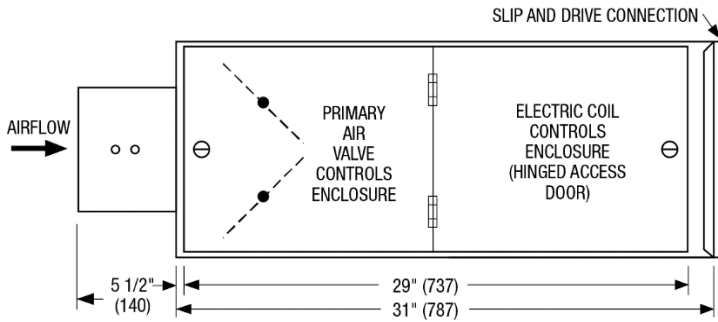

DIMENSIONAL DATA

Unit Size	Min - Max Airflow Range cfm (l/s)	Width (W)	Height (H)	Inlet Size
24x16	960 – 8330 (453 – 3931)	38 (965)	18 (457)	23 7/8 x 15 7/8 (606 x 403) Rect.

Minimum flows are based upon 0.02" w.g. (5 Pa) differential pressure from flow sensor. The maximum flow rate represents the diamond flow sensor's differential pressure reading at 1.5" w.g. (373 Pa).

FEATURES

- 16 ga. (1.61) corrosion-resistant steel inclined opposed blade damper with extruded PVC seals. 45° rotation, CW to close. Tight close-off. Damper leakage is less than 2% of the terminal rated airflow at 3" w.g. (750 Pa)
- 1/2" (13) dia. plated steel drive shaft. An indicator mark on the end of the shaft shows damper position
- Multi-point averaging Diamond Flow Sensor. Aluminum construction. Supplied with balancing tees
- Electric Coil is mounted in an integral attenuator section
- Class A 80/20 Ni/Cr wire
- High performance ceramic insulators
- 24Vac Class II control transformer
- Hinged door control enclosure
- Positive pressure air proving switch
- Primary auto-reset high limit thermal cut-out (one per coil in control circuit)
- Secondary manual reset high limit thermal cut-outs (one per element)

Project: DCH Ambulatory 3rd Floor VAVs
Engineer:
Contractor:

Date: 9/13/2021
Version No: 3.84.02 Rev.11

Dimensions are in inches (mm)

Nailor Industries Inc. reserves the right to change any information concerning product or pricing without notice.

- Magnetic contactor per stage
- Damper Actuator: Not Provided
- NB - Controls: By Others (Field Mounted)
- OR - 22 ga. (0.86) zinc coated steel casing, mechanically sealed, low leakage construction, right hand (determined when looking in the direction of airflow)
- QD2 - Transformer: 480/24V
- FG1 - 1" (25) Steri-Liner
- FN - Full NEMA 1 type 24V Controls Enclosure
- FS - Hanger Brackets
- 4803 - Electric Coil: 480 volt/3 phase/3-wire
- SCR - SCR with 0-10 Vdc Control
- BB - Door-Interlocking disconnect switch

FG1 - Steri-Liner

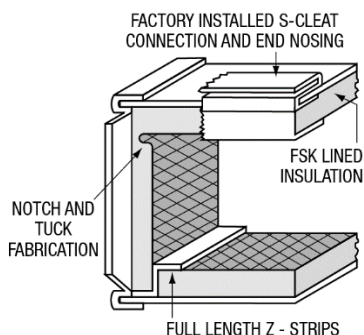

- 1" (25) thick, rigid fiberglass with a fire resistant reinforced aluminum FSK (foil-scrim-kraft) facing
- Meets requirements:
- UL 181 & 723
 - NFPA 90A & 90B
 - ASTM E 84, C 665, C 1071, C 1338, G21 & G22

OR - Top View Orientation- Controls Location

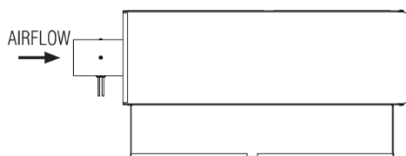

Right Hand Controls Location