



Pro Fit HVAC, LLC

P.O. Box 443
 15713 St. Rt. 116
 St. Marys, OH 45885

Todd Klosterman
 Cell: 419-305-7629
 todd@proairsales.com

Emily Klosterman
 Cell: 419-733-4733
 emily@proairsales.com

SUBMITTAL TRANSMITTAL

Project No.: 2018-05111

NOTE:

Second Floor

Project Description: *(Project Title, Facility Name and Address)*

Dayton Children's
 Ambulatory Renewal Project

Date: 8/27/21

TO:

Cinfab LLC

 5240 Lester Road

 Cincinnati, OH 45213

FROM:

PRO FIT HVAC, LLC

 PO BOX 443

 ST. MARYS, OH 45885

SUBMITTAL TYPE:

- | | | |
|--|---|--|
| <input checked="" type="checkbox"/> For Approval | #1 <input checked="" type="checkbox"/> Re-Submittal | <input type="checkbox"/> Information |
| <input type="checkbox"/> Product Data | <input type="checkbox"/> Shop Drawings | <input type="checkbox"/> Quality Control/Assurance |
| <input type="checkbox"/> Test Reports | <input type="checkbox"/> Certificate | <input type="checkbox"/> Contract Closeout |
| <input type="checkbox"/> Design Data | <input type="checkbox"/> Samples | <input type="checkbox"/> Other |

Specification Number and Title: _____

Part	Type	Description
23 36 16	Air Terminal Units	Nailor Industries

REVIEWED BY HEAPY
 FOR GENERAL CONFORMANCE WITH
 INFORMATION PRESENTED IN THE
 CONTRACT DOCUMENTS ONLY.
APPROVED AS NOTED
 BY: DEREK SHAW / VICTORIA FRANCIS DATE: 9/3/2021

Contractor's Certification:

We have verified that all material or equipment contained in this submittal meets all the requirements specified or shown **(no exceptions)**.

 Contractor/Contractor's Representative (Print Name)

 Signature

Project Name: Dayton Children's Ambulatory Renewal Project 8/27

Project Location:

Engineer:

Contractor:

Contact:

Date: August 27, 2021

Submitted By: PRO FIT HVAC, LLCST. MARY'S, OH
UNITED STATES, 45885

Telephone: (419) 733 - 4733

Fax: (866) 566 - 3655

Contact: Emily Klosterman

PROJECT SCHEDULE**Dayton Children's Ambulatory Renewal Project 8/27****Terminal Units**



Item	Qty	Model	Tag 1	Unit	Max	Min	Aux.	kW
		Option	Codes	Size	Cooling	Cooling	Min	
					CFM	CFM	CFM	
20	1	D30RE	63-2-01	09	855	540	540	4.5
			09- NB- OR- QD2- FG1- FN- FS- 480/3- SCRA- BB					
21	1	D30RE	63-2-02	07	400	300	300	2.5
			07- NB- OR- QD2- FG1- FN- FS- 480/3- SCRA- BB					
22	1	D30RE	63-2-03	09	870	770	770	6.5
			09- NB- OR- QD2- FG1- FN- FS- 480/3- SCRA- BB					
23	1	D30RE	63-2-04	09	650	650	650	7.0
			09- NB- OR- QD2- FG1- FN- FS- 480/3- SCRA- BB					
24	1	D30RE	63-2-05	14	1280	450	835	7.5
			14- NB- OR- QD2- FG1- FN- FS- 480/3- SCRA- BB					
25	1	D30RE	63-2-06	12	1180	350	590	5.0
			12- NB- OR- QD2- FG1- FN- FS- 480/3- SCRA- BB					
26	1	D30RE	63-2-07	14	1555	445	780	6.5
			14- NB- OR- QD2- FG1- FN- FS- 480/3- SCRA- BB					
27	1	D30RE	63-2-08	06	200	150	150	1.5
			06- NB- OR- QD- FG1- FN- FS- 277/1- SCRA- BB					
28	1	D30RE	63-2-09	06	175	165	165	1.5
			06- NB- OR- QD- FG1- FN- FS- 277/1- SCRA- BB					
29	1	D30RE	63-2-10	09	885	605	605	5.0
			09- NB- OR- QD2- FG1- FN- FS- 480/3- SCRA- BB					
30	1	D30RE	63-2-11	12	1175	340	765	8.0
			12- NB- OR- QD2- FG1- FN- FS- 480/3- SCRA- BB					
31	1	D30RE	63-2-12	14	1175	400	1115	12.5
			14- NB- OR- QD2- FG1- FN- FS- 480/3- SCRA- BB					

Dimensions are in inches (mm)

Nailor Industries Inc. reserves the right to change any information concerning product or pricing without notice.

PROJECT SCHEDULE**Dayton Children's Ambulatory Renewal Project 8/27****Terminal Units**

Item	Qty	Model	Tag 1	Unit	Max Cooling CFM	Min Cooling CFM	Aux. Min CFM	kW
32	1	D30RE	63-2-13	12	1200	300	600	5.0
			12- NB- OR- QD2- FG1- FN- FS- 480/3- SCRA- BB					
33	1	D30RE	63-2-14	24	3500	1000	2275	23.0
			24- NB- OR- QD2- FG1- FN- FS- 480/3- SCRA- BB					
34	1	D30RE	63-2-15	06	200	70	100	1.0
			06- NB- OR- QD- FG1- FN- FS- 277/1- SCRA- BB					
35	1	D30RE	63-2-16	24	2420	1105	2180	25.0
			24- NB- OR- QD2- FG1- FN- FS- 480/3- SCRA- BB					
36	1	D30RE	63-2-17	06	150	70	75	1.0
			06- NB- OR- QD- FG1- FN- FS- 277/1- SCRA- BB					
37	1	D30RE	63-2-18	06	300	300	300	2.5
			06- NB- OR- QD2- FG1- FN- FS- 480/3- SCRA- BB					
38	1	D30RE	63-2-19	07	370	100	185	1.5
			07- NB- OR- QD- FG1- FN- FS- 277/1- SCRA- BB					
40	1	D30RE	63-2-20	06	200	150	150	1.5
			06- NB- OR- QD- FG1- FN- FS- 277/1- SCRA- BB					
71	1	D30RE	64-2-01	07	415	185	295	3.5
			07- NB- OR- QD2- FG1- FN- FS- 480/3- SCRA- BB					
72	1	D30RE	64-2-02	12	900	340	675	7.5
			12- NB- OR- QD2- FG1- FN- FS- 480/3- SCRA- BB					
73	1	D30RE	64-2-03	06	125	125	125	1.0
			06- NB- OR- QD- FG1- FN- FS- 277/1- SCRA- BB					
74	1	D30RE	64-2-04	07	400	210	280	3.5
			07- NB- OR- QD2- FG1- FN- FS- 480/3- SCRA- BB					
75	1	D30RE	64-2-05	12	1060	440	530	5.0
			12- NB- OR- QD2- FG1- FN- FS- 480/3- SCRA- BB					
76	1	D30RE	64-2-06	08	600	250	300	3.5
			08- NB- OR- QD2- FG1- FN- FS- 480/3- SCRA- BB					
77	1	D30RE	64-2-07	09	640	180	515	6.0
			09- NB- OR- QD2- FG1- FN- FS- 480/3- SCRA- BB					

Dimensions are in inches (mm)

Nailor Industries Inc. reserves the right to change any information concerning product or pricing without notice.

PROJECT SCHEDULE**Dayton Children's Ambulatory Renewal Project 8/27****Terminal Units**

Item	Qty	Model	Tag 1	Unit	Max Cooling CFM	Min Cooling CFM	Aux. Min CFM	kW
78	1	D30RE	64-2-08	08	600	155	480	5.5
			08- NB- OR- QD2- FG1- FN- FS- 480/3- SCRA- BB					
79	1	D30RE	64-2-09	12	895	720	720	6.0
			12- NB- OR- QD2- FG1- FN- FS- 480/3- SCRA- BB					
80	1	D30RE	64-2-10	12	1150	1150	1150	9.5
			12- NB- OR- QD2- FG1- FN- FS- 480/3- SCRA- BB					
81	1	D30RE	64-2-11	06	200	155	155	1.5
			06- NB- OR- QD- FG1- FN- FS- 277/1- SCRA- BB					
82	1	D30RE	64-2-12	06	200	200	200	2.0
			06- NB- OR- QD- FG1- FN- FS- 277/1- SCRA- BB					
83	1	D30RE	64-2-13	07	400	300	300	2.5
			07- NB- OR- QD2- FG1- FN- FS- 480/3- SCRA- BB					
84	1	D30RE	64-2-14	12	1135	1135	1135	9.5
			12- NB- OR- QD2- FG1- FN- FS- 480/3- SCRA- BB					
85	1	D30RE	64-2-15	06	300	225	225	2.0
			06- NB- OR- QD- FG1- FN- FS- 277/1- SCRA- BB					
86	1	D30RE	64-2-16	06	300	225	225	2.0
			06- NB- OR- QD- FG1- FN- FS- 277/1- SCRA- BB					
87	1	D30RE	64-2-17	06	175	165	165	1.5
			06- NB- OR- QD- FG1- FN- FS- 277/1- SCRA- BB					
88	1	D30RE	64-2-18	06	175	165	165	1.5
			06- NB- OR- QD- FG1- FN- FS- 277/1- SCRA- BB					
89	1	D30RE	64-2-19	06	305	90	155	1.5
			06- NB- OR- QD- FG1- FN- FS- 277/1- SCRA- BB					
90	1	D30RE	64-2-20	06	200	150	150	1.5
			06- NB- OR- QD- FG1- FN- FS- 277/1- SCRA- BB					
91	1	D30RE	64-2-21	07	535	535	535	5.0
			07- NB- OR- QD2- FG1- FN- FS- 480/3- SCRA- BB					
92	1	D30RE	64-2-23	06	355	355	355	3.0
			06- NB- OR- QD2- FG1- FN- FS- 480/3- SCRA- BB					

Dimensions are in inches (mm)

Nailor Industries Inc. reserves the right to change any information concerning product or pricing without notice.

PROJECT SCHEDULE**Dayton Children's Ambulatory Renewal Project 8/27****Terminal Units**



Item	Qty	Model	Tag 1	Unit	Max	Min	Aux.	kW
		Option	Codes	Size	Cooling	Cooling	Min	
					CFM	CFM	CFM	
93	1	D30RE	64-2-24	06	200	200	200	2.0
			06- NB- OR- QD- FG1- FN- FS- 277/1- SCRA- BB					
94	1	D30RE	64-2-25	06	135	70	70	1.0
			06- NB- OR- QD- FG1- FN- FS- 277/1- SCRA- BB					
95	1	D30RE	64-2-26	06	165	165	165	1.5
			06- NB- OR- QD- FG1- FN- FS- 277/1- SCRA- BB					
96	1	D30RE	64-2-27	06	185	70	115	1.5
			06- NB- OR- QD- FG1- FN- FS- 277/1- SCRA- BB					
97	1	D30RE	64-2-28	12	1025	1025	1025	8.5
			12- NB- OR- QD2- FG1- FN- FS- 480/3- SCRA- BB					
98	1	D30RE	64-2-29	16	2000	500	1000	9.5
			16- NB- OR- QD2- FG1- FN- FS- 480/3- SCRA- BB					

Dimensions are in inches (mm)

Nailor Industries Inc. reserves the right to change any information concerning product or pricing without notice.

Items: 1, 4, 5, 10, 14, 20, 21, 22, 23, 29, 42, 43, 44, 45, 46, 47, 48, 51, 58, 60, 65, 71, 74, 76, 77, 78, 83, 91; Tags:
 63-2-01; 63-2-02; 63-2-03; 63-2-04; 63-2-10;
 64-2-01; 64-2-04; 64-2-06; 64-2-07; 64-2-08; 64-2-13; 64-2-21

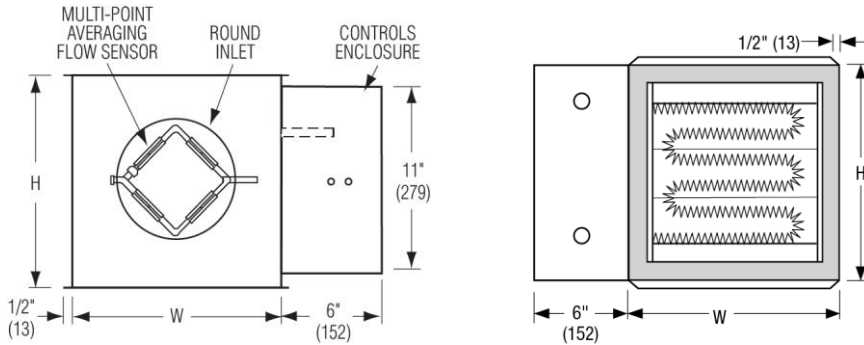
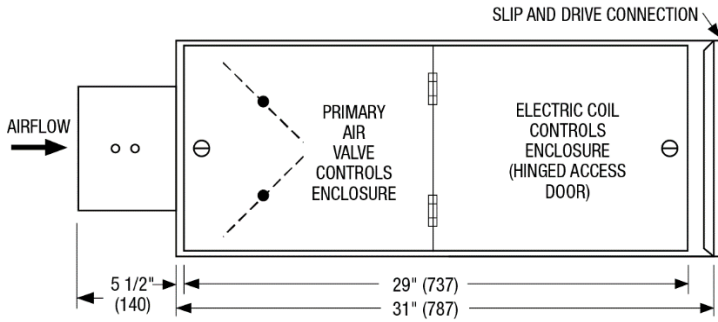

Right-hand controls location shown
 *Controls Enclosure optional with field mounted controls

DIMENSIONAL DATA

Unit Size	Min - Max Airflow Range cfm (l/s)	Width (W)	Height (H)	Inlet Size
7	95 – 800 (45 – 378)	12 (305)	12 1/2 (318)	6 7/8 (175) Round
8	125 – 1100 (59 – 519)	12 (305)	12 1/2 (318)	7 7/8 (200) Round
9	165 – 1400 (78 – 661)	14 (356)	12 1/2 (318)	8 7/8 (225) Round

Minimum flows are based upon 0.02" w.g. (5 Pa) differential pressure from flow sensor. The maximum flow rate represents the diamond flow sensor's differential pressure reading at 1.5" w.g. (373 Pa).

FEATURES

- 16 ga. (1.61) corrosion-resistant steel inclined opposed blade damper with extruded PVC seals. 45° rotation, CW to close. Tight close-off. Damper leakage is less than 2% of the terminal rated airflow at 3" w.g. (750 Pa)

Project: Dayton Children's Ambulatory Renewal Project 8/27
Engineer:
Contractor:

Date: 8/27/2021
Version No: 3.84.02 Rev.11

Dimensions are in inches (mm)

Nailor Industries Inc. reserves the right to change any information concerning product or pricing without notice.

- 1/2" (13) dia. plated steel drive shaft. An indicator mark on the end of the shaft shows damper position
- Multi-point averaging Diamond Flow Sensor. Aluminum construction. Supplied with balancing tees
- Electric Coil is mounted in an integral attenuator section
- Class A 80/20 Ni/Cr wire
- High performance ceramic insulators
- 24Vac Class II control transformer
- Hinged door control enclosure
- Positive pressure air proving switch
- Primary auto-reset high limit thermal cut-out (one per coil in control circuit)
- Secondary manual reset high limit thermal cut-outs (one per element)
- Magnetic contactor per stage
- Damper Actuator: Not Provided
- NB - Controls: By Others (Field Mounted)
- OR - 22 ga. (0.86) zinc coated steel casing, mechanically sealed, low leakage construction, right hand (determined when looking in the direction of airflow)
- QD2 - Transformer: 480/24V
- FG1 - 1" (25) Steri-Liner
- FN - Full NEMA 1 type 24V Controls Enclosure
- FS - Hanger Brackets
- 4803 - Electric Coil: 480 volt/3 phase/3-wire
- SCRA - SCR with 4-20 mA Control
- BB - Door-Interlocking disconnect switch

FG1 - Steri-Liner

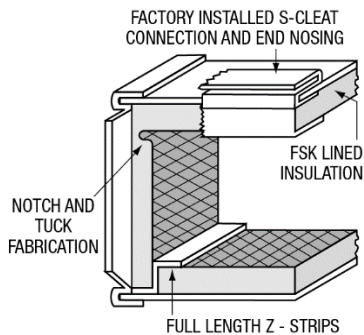

- 1" (25) thick, rigid fiberglass with a fire resistant reinforced aluminum FSK (foil-scrim-kraft) facing
- Meets requirements:
- UL 181 & 723
 - NFPA 90A & 90B
 - ASTM E 84, C 665, C 1071, C 1338, G21 & G22

OR - Top View Orientation- Controls Location

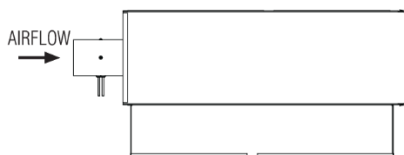

Right Hand Controls Location

Project: Dayton Children's Ambulatory Renewal Project 8/27

Date: 8/27/2021

Engineer:

Version No: 3.84.02 Rev.11

Contractor:

Dimensions are in inches (mm)

Nailor Industries Inc. reserves the right to change any information concerning product or pricing without notice.

Items: 2, 33, 35; Tags:

63-2-14; 63-2-16

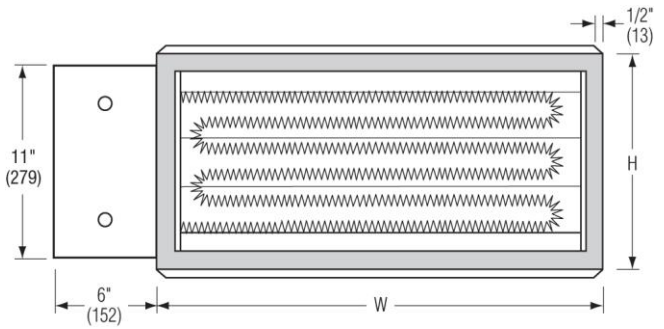
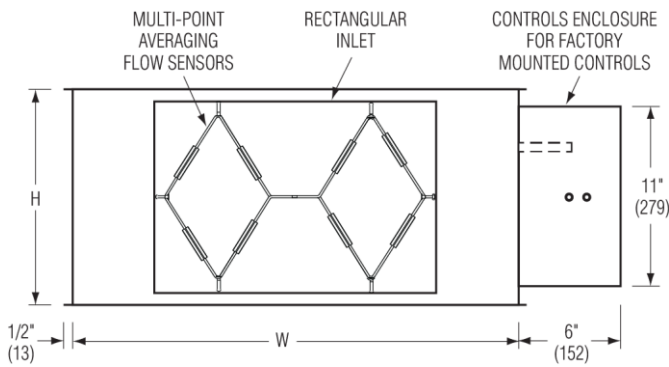
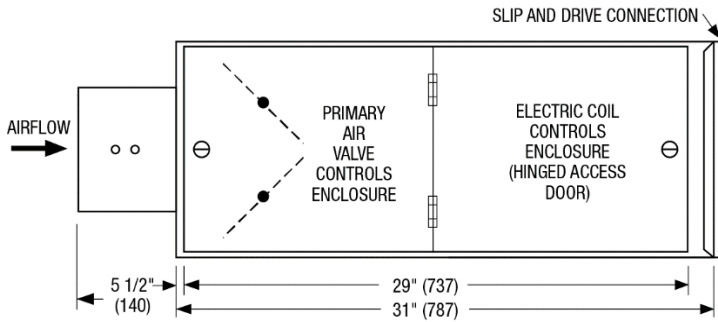

DIMENSIONAL DATA

Unit Size	Min - Max Airflow Range cfm (l/s)	Width (W)	Height (H)	Inlet Size
24x16	960 – 8330 (453 – 3931)	38 (965)	18 (457)	23 7/8 x 15 7/8 (606 x 403) Rect.

Minimum flows are based upon 0.02" w.g. (5 Pa) differential pressure from flow sensor. The maximum flow rate represents the diamond flow sensor's differential pressure reading at 1.5" w.g. (373 Pa).

FEATURES

- 16 ga. (1.61) corrosion-resistant steel inclined opposed blade damper with extruded PVC seals. 45° rotation, CW to close. Tight close-off. Damper leakage is less than 2% of the terminal rated airflow at 3" w.g. (750 Pa)
- 1/2" (13) dia. plated steel drive shaft. An indicator mark on the end of the shaft shows damper position
- Multi-point averaging Diamond Flow Sensor. Aluminum construction. Supplied with balancing tees
- Electric Coil is mounted in an integral attenuator section
- Class A 80/20 Ni/Cr wire
- High performance ceramic insulators
- 24Vac Class II control transformer
- Hinged door control enclosure
- Positive pressure air proving switch
- Primary auto-reset high limit thermal cut-out (one per coil in control circuit)
- Secondary manual reset high limit thermal cut-outs (one per element)

Project: Dayton Children's Ambulatory Renewal Project 8/27

Date: 8/27/2021

Engineer:

Version No: 3.84.02 Rev.11

Contractor:

Dimensions are in inches (mm)

Nailor Industries Inc. reserves the right to change any information concerning product or pricing without notice.

- Magnetic contactor per stage
- Damper Actuator: Not Provided
- NB - Controls: By Others (Field Mounted)
- OR - 22 ga. (0.86) zinc coated steel casing, mechanically sealed, low leakage construction, right hand (determined when looking in the direction of airflow)
- QD2 - Transformer: 480/24V
- FG1 - 1" (25) Steri-Liner
- FN - Full NEMA 1 type 24V Controls Enclosure
- FS - Hanger Brackets
- 4803 - Electric Coil: 480 volt/3 phase/3-wire
- SCRA - SCR with 4-20 mA Control
- BB - Door-Interlocking disconnect switch

FG1 - Steri-Liner

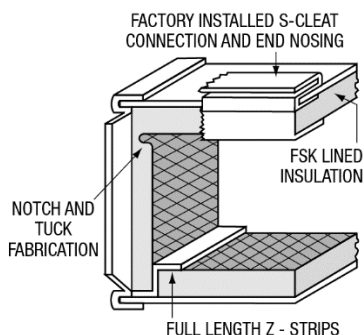

- 1" (25) thick, rigid fiberglass with a fire resistant reinforced aluminum FSK (foil-scrim-kraft) facing
- Meets requirements:
- UL 181 & 723
 - NFPA 90A & 90B
 - ASTM E 84, C 665, C 1071, C 1338, G21 & G22

OR - Top View Orientation- Controls Location

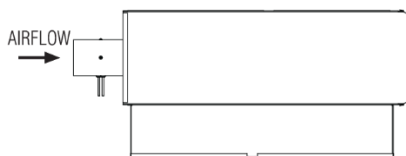

Right Hand Controls Location

Items: 3, 24, 25, 26, 30, 31, 32, 53, 61, 72, 75, 79, 80, 84, 97, 98; Tags: 63-2-05; 63-2-06; 63-2-07; 63-2-11; 63-2-12; 63-2-13; 64-2-02; 64-2-05; 64-2-09; 64-2-10; 64-2-14; 64-2-28; 64-2-29

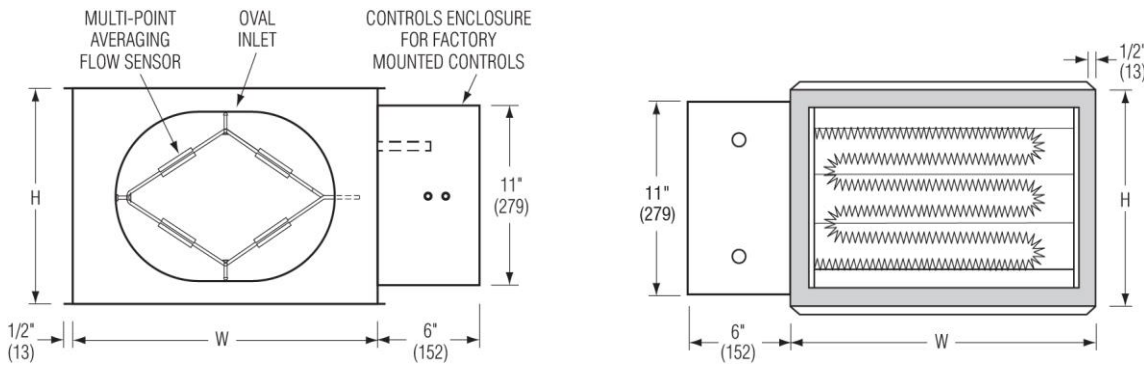
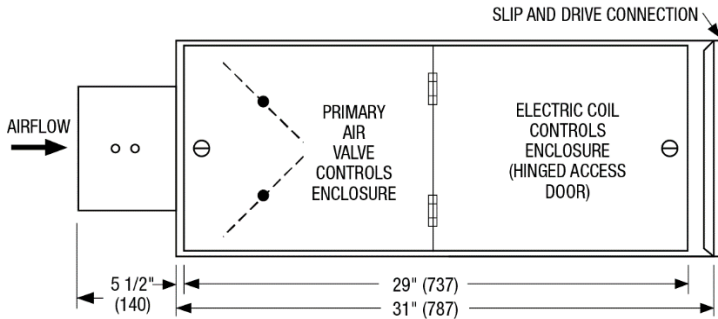

DIMENSIONAL DATA

Unit Size	Min - Max Airflow Range cfm (l/s)	Width (W)	Height (H)	Inlet Size
12	290 – 2500 (137 – 1180)	18 (457)	12 1/2 (318)	12 15/16 x 9 13/16 (329 x 249) Oval
14	360 – 3125 (170 – 1475)	24 (610)	12 1/2 (318)	16 1/16 x 9 13/16 (408 x 249) Oval
16	430 – 3725 (203 – 1758)	28 (711)	12 1/2 (318)	19 3/16 x 9 13/16 (487 x 249) Oval

Minimum flows are based upon 0.02" w.g. (5 Pa) differential pressure from flow sensor. The maximum flow rate represents the diamond flow sensor's differential pressure reading at 1.5" w.g. (373 Pa).

FEATURES

- 16 ga. (1.61) corrosion-resistant steel inclined opposed blade damper with extruded PVC seals. 45° rotation, CW to close. Tight close-off. Damper leakage is less than 2% of the terminal rated airflow at 3" w.g. (750 Pa)
- 1/2" (13) dia. plated steel drive shaft. An indicator mark on the end of the shaft shows damper position
- Multi-point averaging Diamond Flow Sensor. Aluminum construction. Supplied with balancing tees
- Electric Coil is mounted in an integral attenuator section
- Class A 80/20 Ni/Cr wire
- High performance ceramic insulators

Project: Dayton Children's Ambulatory Renewal Project 8/27

Date: 8/27/2021

Engineer:

Version No: 3.84.02 Rev.11

Contractor:

Dimensions are in inches (mm)

Nailor Industries Inc. reserves the right to change any information concerning product or pricing without notice.

- 24Vac Class II control transformer
- Hinged door control enclosure
- Positive pressure air proving switch
- Primary auto-reset high limit thermal cut-out (one per coil in control circuit)
- Secondary manual reset high limit thermal cut-outs (one per element)
- Magnetic contactor per stage
- Damper Actuator: Not Provided
- NB - Controls: By Others (Field Mounted)
- OR - 22 ga. (0.86) zinc coated steel casing, mechanically sealed, low leakage construction, right hand (determined when looking in the direction of airflow)
- QD2 - Transformer: 480/24V
- FG1 - 1" (25) Steri-Liner
- FN - Full NEMA 1 type 24V Controls Enclosure
- FS - Hanger Brackets
- 4803 - Electric Coil: 480 volt/3 phase/3-wire
- SCRA - SCR with 4-20 mA Control
- BB - Door-Interlocking disconnect switch

FG1 - Steri-Liner

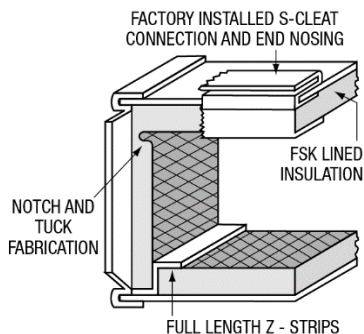

- 1" (25) thick, rigid fiberglass with a fire resistant reinforced aluminum FSK (foil-scrim-kraft) facing
- Meets requirements:
- UL 181 & 723
 - NFPA 90A & 90B
 - ASTM E 84, C 665, C 1071, C 1338, G21 & G22

OR - Top View Orientation- Controls Location

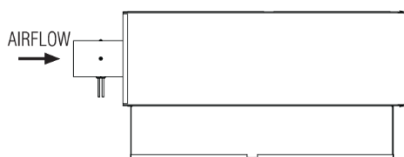

Right Hand Controls Location

Project: Dayton Children's Ambulatory Renewal Project 8/27

Date: 8/27/2021

Engineer:

Version No: 3.84.02 Rev.11

Contractor:

Dimensions are in inches (mm)

Nailor Industries Inc. reserves the right to change any information concerning product or pricing without notice.

Items: 6, 38, 50, 64; Tags: 63-2-19;

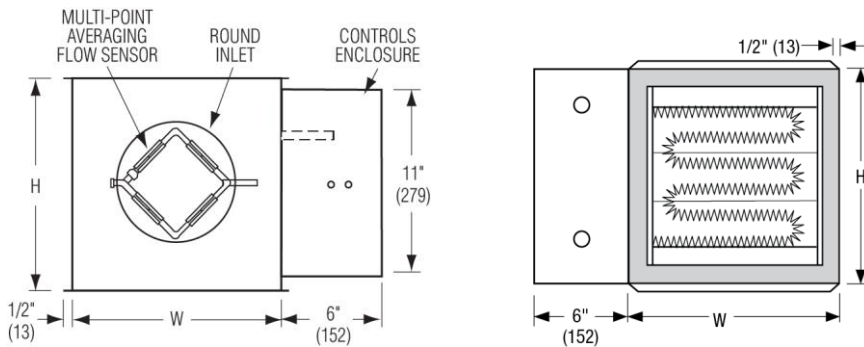
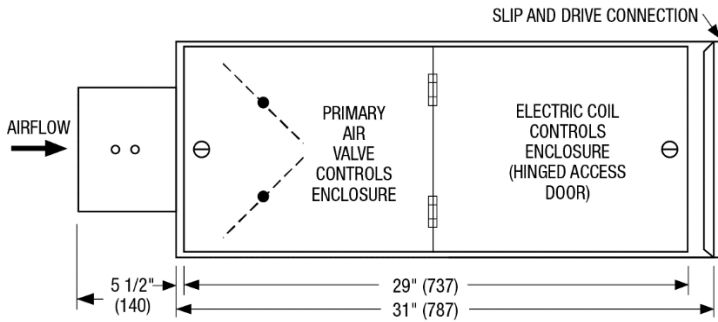

Right-hand controls location shown

*Controls Enclosure optional with field mounted controls

DIMENSIONAL DATA

Unit Size	Min - Max Airflow Range cfm (l/s)	Width (W)	Height (H)	Inlet Size
7	95 – 800 (45 – 378)	12 (305)	12 1/2 (318)	6 7/8 (175) Round

Minimum flows are based upon 0.02" w.g. (5 Pa) differential pressure from flow sensor. The maximum flow rate represents the diamond flow sensor's differential pressure reading at 1.5" w.g. (373 Pa).

FEATURES

- 16 ga. (1.61) corrosion-resistant steel inclined opposed blade damper with extruded PVC seals. 45° rotation, CW to close. Tight close-off. Damper leakage is less than 2% of the terminal rated airflow at 3" w.g. (750 Pa)
- 1/2" (13) dia. plated steel drive shaft. An indicator mark on the end of the shaft shows damper position
- Multi-point averaging Diamond Flow Sensor. Aluminum construction. Supplied with balancing tees
- Electric Coil is mounted in an integral attenuator section
- Class A 80/20 Ni/Cr wire
- High performance ceramic insulators
- 24Vac Class II control transformer
- Hinged door control enclosure

Project: Dayton Children's Ambulatory Renewal Project 8/27

Date: 8/27/2021

Engineer:

Version No: 3.84.02 Rev.11

Contractor:

Dimensions are in inches (mm)

Nailor Industries Inc. reserves the right to change any information concerning product or pricing without notice.

- Positive pressure air proving switch
- Primary auto-reset high limit thermal cut-out (one per coil in control circuit)
- Secondary manual reset high limit thermal cut-outs (one per element)
- Magnetic contactor per stage
- Damper Actuator: Not Provided
- NB - Controls: By Others (Field Mounted)
- OR - 22 ga. (0.86) zinc coated steel casing, mechanically sealed, low leakage construction, right hand (determined when looking in the direction of airflow)
- QD - Transformer: 277/24V
- FG1 - 1" (25) Steri-Liner
- FN - Full NEMA 1 type 24V Controls Enclosure
- FS - Hanger Brackets
- 2771 - Electric Coil: 277 volt/1 phase/2-wire
- SCRA - SCR with 4-20 mA Control
- BB - Door-Interlocking disconnect switch

FG1 - Steri-Liner

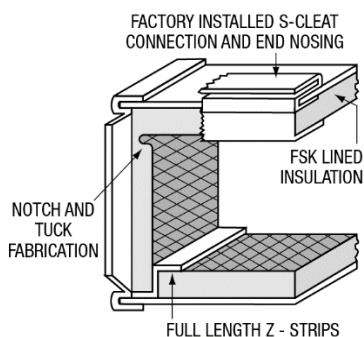

- 1" (25) thick, rigid fiberglass with a fire resistant reinforced aluminum FSK (foil-scrim-kraft) facing
- Meets requirements:
 - UL 181 & 723
 - NFPA 90A & 90B
 - ASTM E 84, C 665, C 1071, C 1338, G21 & G22

OR - Top View Orientation- Controls Location

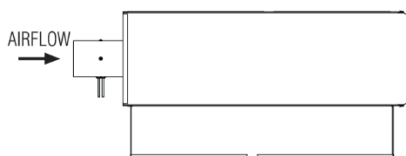

Right Hand Controls Location

Project: Dayton Children's Ambulatory Renewal Project 8/27

Date: 8/27/2021

Engineer:

Version No: 3.84.02 Rev.11

Contractor:

Dimensions are in inches (mm)

Items: 7, 8, 9, 11, 12, 13, 15, 16, 17, 18, 19, 27, 28, 34, 36, 40, 49, 52, 54, 55, 56, 57, 59, 62, 66, 67, 68, 69, 70, 73, 81, 82, 85, 86, 87, 88, 89, 90, 93, 94, 95, 96; Tags:
 63-2-08; 63-2-09; 63-2-15; 63-2-17; 63-2-20;
 64-2-03; 64-2-11; 64-2-12; 64-2-15; 64-2-16; 64-2-17; 64-2-18; 64-2-19; 64-2-20; 64-2-24; 64-2-25; 64-2-26; 64-2-27

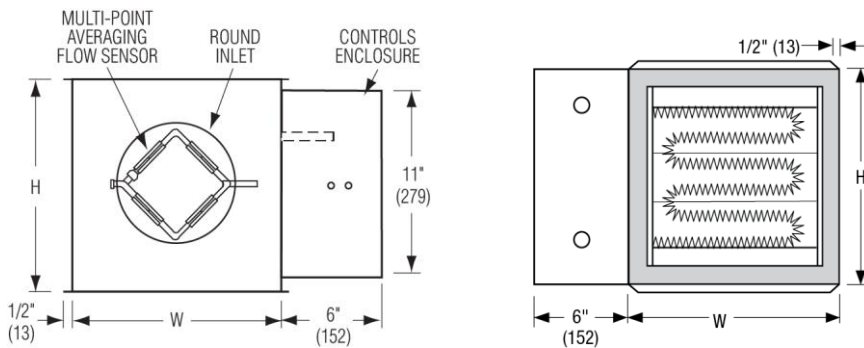
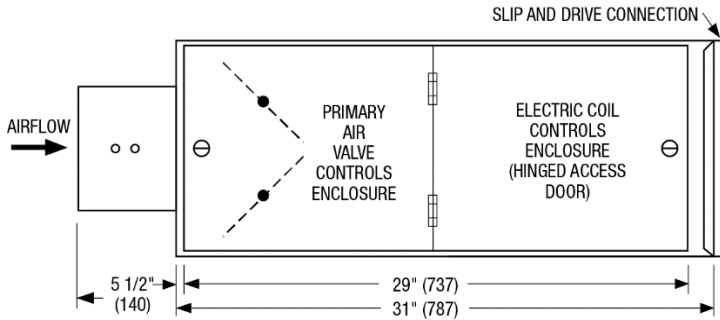

Right-hand controls location shown
 *Controls Enclosure optional with field mounted controls

DIMENSIONAL DATA

Unit Size	Min - Max Airflow Range cfm (l/s)	Width (W)	Height (H)	Inlet Size
6	65 – 550 (31 – 260)	10 (254)	10 (254)	5 7/8 (149) Round

Minimum flows are based upon 0.02" w.g. (5 Pa) differential pressure from flow sensor. The maximum flow rate represents the diamond flow sensor's differential pressure reading at 1.5" w.g. (373 Pa).

FEATURES

- 16 ga. (1.61) corrosion-resistant steel inclined single blade damper with extruded PVC seals. 45° rotation, CW to close. Tight close-off. Damper leakage is less than 2% of the terminal rated airflow at 3" w.g. (750 Pa)
- 1/2" (13) dia. plated steel drive shaft. An indicator mark on the end of the shaft shows damper position
- Multi-point averaging Diamond Flow Sensor. Aluminum construction. Supplied with balancing tees
- Electric Coil is mounted in an integral attenuator section

Project: Dayton Children's Ambulatory Renewal Project 8/27
Engineer:
Contractor:

Date: 8/27/2021
Version No: 3.84.02 Rev.11

Dimensions are in inches (mm)

Nailor Industries Inc. reserves the right to change any information concerning product or pricing without notice.

- Class A 80/20 Ni/Cr wire
- High performance ceramic insulators
- 24Vac Class II control transformer
- Hinged door control enclosure
- Positive pressure air proving switch
- Primary auto-reset high limit thermal cut-out (one per coil in control circuit)
- Secondary manual reset high limit thermal cut-outs (one per element)
- Magnetic contactor per stage
- Damper Actuator: Not Provided
- NB - Controls: By Others (Field Mounted)
- OR - 22 ga. (0.86) zinc coated steel casing, mechanically sealed, low leakage construction, right hand (determined when looking in the direction of airflow)
- QD - Transformer: 277/24V
- FG1 - 1" (25) Steri-Liner
- FN - Full NEMA 1 type 24V Controls Enclosure
- FS - Hanger Brackets
- 2771 - Electric Coil: 277 volt/1 phase/2-wire
- SCRA - SCR with 4-20 mA Control
- BB - Door-Interlocking disconnect switch

FG1 - Steri-Liner

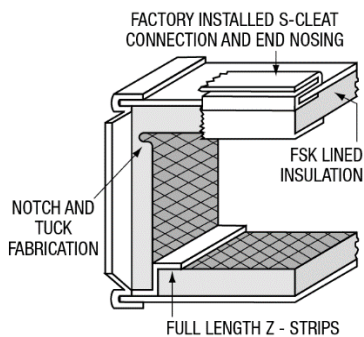

- 1" (25) thick, rigid fiberglass with a fire resistant reinforced aluminum FSK (foil-scrim-kraft) facing
- Meets requirements:
- UL 181 & 723
 - NFPA 90A & 90B
 - ASTM E 84, C 665, C 1071, C 1338, G21 & G22

OR - Top View Orientation- Controls Location

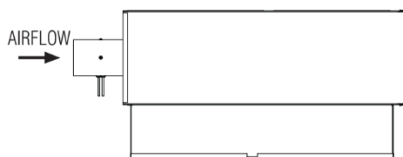

Right Hand Controls Location

Project: Dayton Children's Ambulatory Renewal Project 8/27

Date: 8/27/2021

Engineer:

Version No: 3.84.02 Rev.11

Contractor:

Dimensions are in inches (mm)

Nailor Industries Inc. reserves the right to change any information concerning product or pricing without notice.

Items: 37, 41, 63, 92; Tags: 63-2-18;

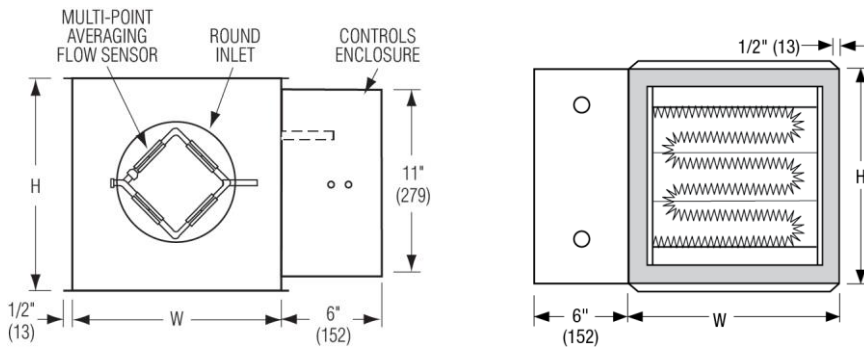
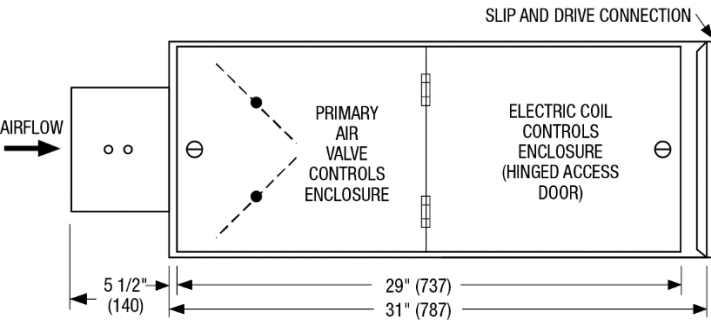

Right-hand controls location shown

*Controls Enclosure optional with field mounted controls

DIMENSIONAL DATA

Unit Size	Min - Max Airflow Range cfm (l/s)	Width (W)	Height (H)	Inlet Size
6	65 – 550 (31 – 260)	10 (254)	10 (254)	5 7/8 (149) Round

Minimum flows are based upon 0.02" w.g. (5 Pa) differential pressure from flow sensor. The maximum flow rate represents the diamond flow sensor's differential pressure reading at 1.5" w.g. (373 Pa).

FEATURES

- 16 ga. (1.61) corrosion-resistant steel inclined single blade damper with extruded PVC seals. 45° rotation, CW to close. Tight close-off. Damper leakage is less than 2% of the terminal rated airflow at 3" w.g. (750 Pa)
- 1/2" (13) dia. plated steel drive shaft. An indicator mark on the end of the shaft shows damper position
- Multi-point averaging Diamond Flow Sensor. Aluminum construction. Supplied with balancing tees
- Electric Coil is mounted in an integral attenuator section
- Class A 80/20 Ni/Cr wire
- High performance ceramic insulators
- 24Vac Class II control transformer
- Hinged door control enclosure

Project: Dayton Children's Ambulatory Renewal Project 8/27

Date: 8/27/2021

Engineer:

Version No: 3.84.02 Rev.11

Contractor:

Dimensions are in inches (mm)

Nailor Industries Inc. reserves the right to change any information concerning product or pricing without notice.

- Positive pressure air proving switch
- Primary auto-reset high limit thermal cut-out (one per coil in control circuit)
- Secondary manual reset high limit thermal cut-outs (one per element)
- Magnetic contactor per stage
- Damper Actuator: Not Provided
- NB - Controls: By Others (Field Mounted)
- OR - 22 ga. (0.86) zinc coated steel casing, mechanically sealed, low leakage construction, right hand (determined when looking in the direction of airflow)
- QD2 - Transformer: 480/24V
- FG1 - 1" (25) Steri-Liner
- FN - Full NEMA 1 type 24V Controls Enclosure
- FS - Hanger Brackets
- 4803 - Electric Coil: 480 volt/3 phase/3-wire
- SCRA - SCR with 4-20 mA Control
- BB - Door-Interlocking disconnect switch

FG1 - Steri-Liner

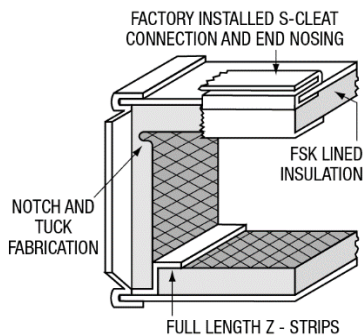

- 1" (25) thick, rigid fiberglass with a fire resistant reinforced aluminum FSK (foil-scrim-kraft) facing
- Meets requirements:
- UL 181 & 723
 - NFPA 90A & 90B
 - ASTM E 84, C 665, C 1071, C 1338, G21 & G22

OR - Top View Orientation- Controls Location

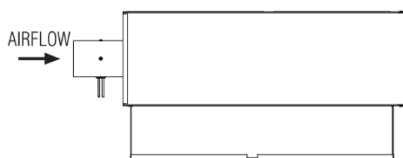

Right Hand Controls Location

Project: Dayton Children's Ambulatory Renewal Project 8/27

Date: 8/27/2021

Engineer:

Version No: 3.84.02 Rev.11

Contractor:

Dimensions are in inches (mm)

Nailor Industries Inc. reserves the right to change any information concerning product or pricing without notice.