

CAPTRATE SOLO FILTERS

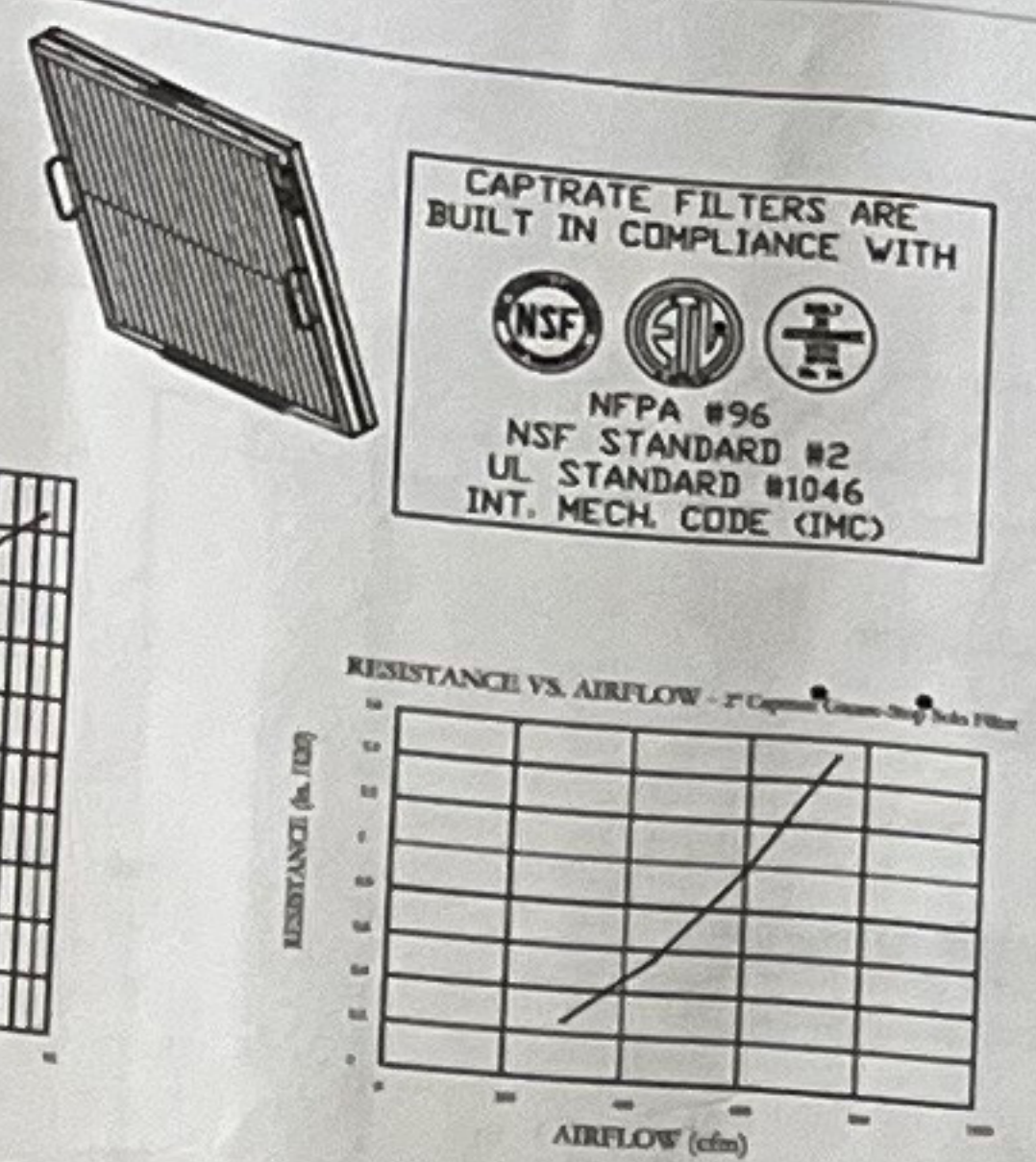
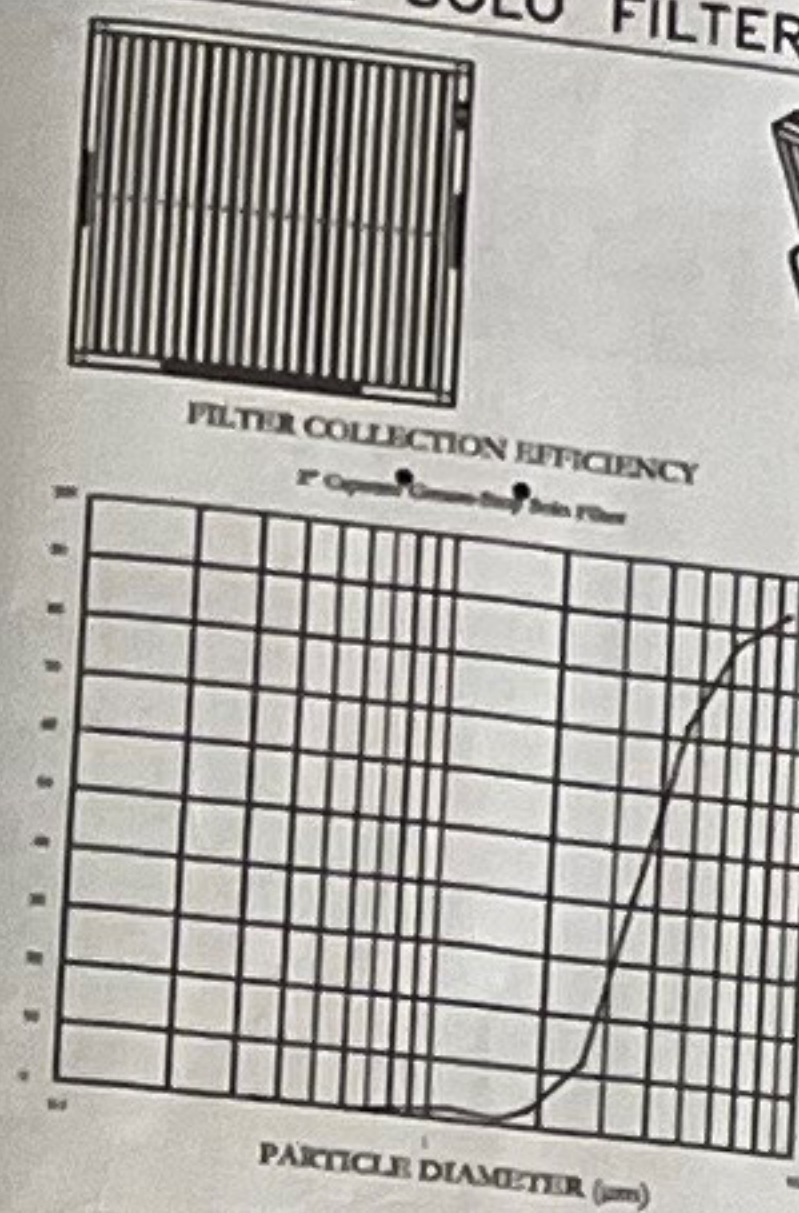

CAPTRATE FILTERS ARE BUILT IN COMPLIANCE WITH
 NSF #96
 NFPA #36
 UL STANDARD #1046
 INT. MECH. CODE (IMC)

SPECIFICATION CAPTRATE® GREASE-STOP® SOLO FILTER
 THE CAPTRATE GREASE-STOP SOLO FILTER IS A SINGLE-STAGE FILTER FEATURING A UNIQUE S-Baffle DESIGN IN CONJUNCTION WITH A SLOTTED REAR BAFFLE DESIGN TO DELIVER EXCEPTIONAL FILTRATION EFFICIENCY.
 FILTER IS CONSTRUCTED OF 430 STAINLESS STEEL, AND SIZED TO FIT INTO STANDARD 2-INCH DEEP HOOD CHANNELS.
 UNITS SHALL INCLUDE STAINLESS STEEL HANDLES AND A FASTENING DEVICE TO SECURE THE TWO COMPONENTS WHEN ASSEMBLED.
 GREASE EXTRACTION EFFICIENCY PERFORMANCE SHALL REMOVE AT LEAST 75% OF GREASE PARTICLES FIVE MICRONS IN SIZE, AND 90% GREASE PARTICLES SEVEN MICRONS IN SIZE AND LARGER, WITH A CORRESPONDING PRESSURE DROP NOT TO EXCEED 1.0 INCHES OF WATER GAUGE.

FILTER INFORMATION - CAPTRATE® GREASE-STOP® SOLO

NOMINAL SIZE (H x W)	ACTUAL DIMENSIONS (H x W x D)	FREE AREA (SQ. FEET)	WEIGHT (POUNDS)	VELOCITY (FEET PER MINUTE)	STATIC PRESSURE (WATER GAUGE)
20 x 20	19-5/8" x 19-5/8" x 1-7/8"	2.26	8.2	100	0.25
20 x 24	19-5/8" x 23-5/8" x 1-7/8"	2.78	9.1	100	0.25
16 x 20	15-5/8" x 15-5/8" x 1-7/8"	1.78	6.8	125	0.35
16 x 24	15-5/8" x 23-5/8" x 1-7/8"	2.26	7.4	125	0.35
12 x 20	11-5/8" x 11-5/8" x 1-7/8"	1.29	4.6	150	0.50
12 x 24	11-5/8" x 23-5/8" x 1-7/8"	1.78	5.6	150	0.50
10 x 20	9-5/8" x 9-5/8" x 1-7/8"	0.96	3.6	175	0.75
10 x 24	9-5/8" x 23-5/8" x 1-7/8"	1.29	4.6	175	0.75

CAPTIVE-AIRE HOODS ARE BUILT IN COMPLIANCE WITH:
 • NFPA #36
 • NSF
 • ETL Listed
 • CALIFORNIA MECHANICAL CODE
 • INTERNATIONAL MECHANICAL CODE



BUILDING CODES

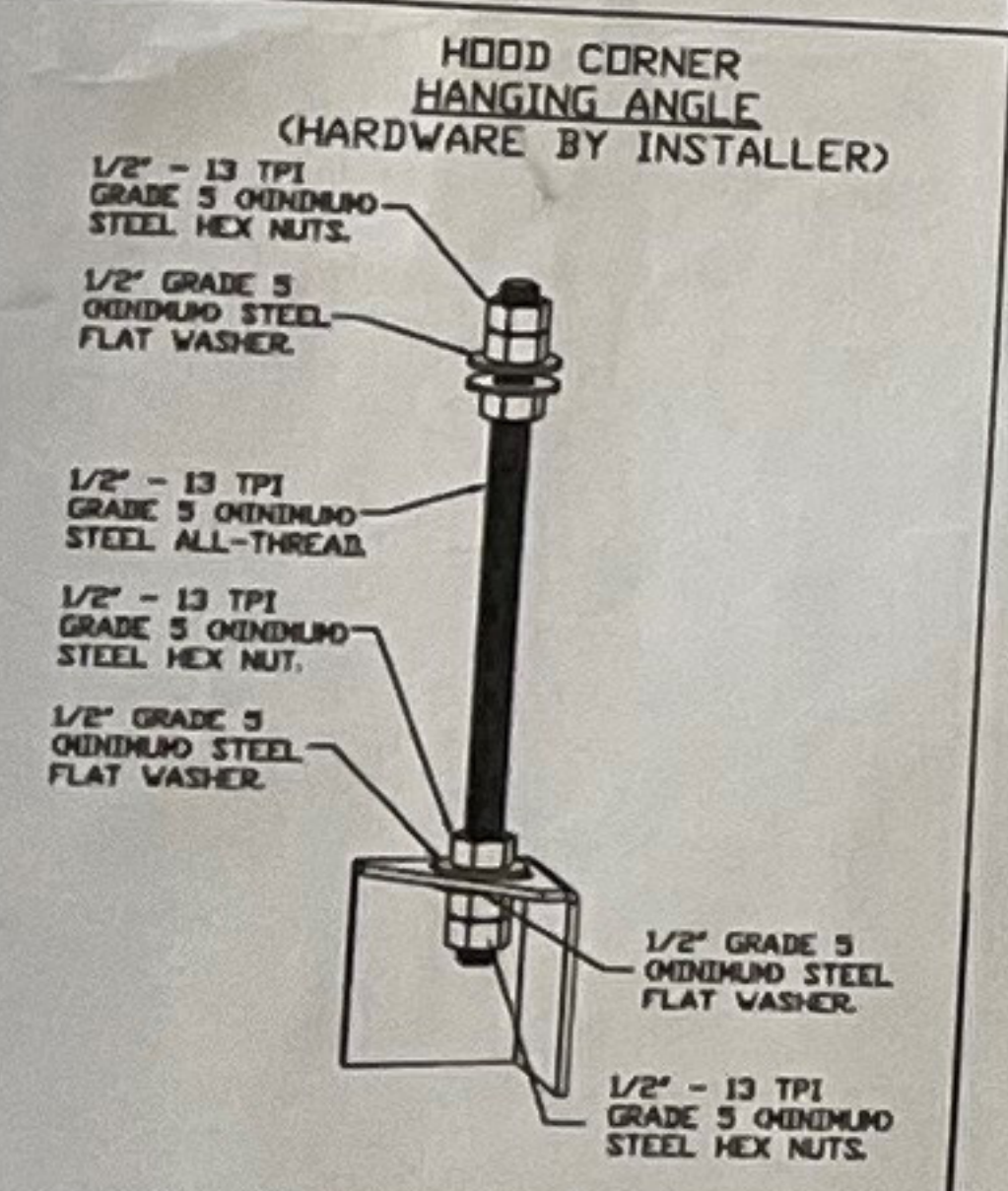

ASSEMBLY INSTRUCTIONS
 HANGING ANGLE MUST BE SUPPORTED WITH 1/2\"/>

ND-2 HANGING ANGLE DETAIL
 HANGING ANGLES WILL BE LOCATED IN THE FOLLOWING LOCATIONS FOR WALL CANOPIES

HOOD STYLE	DIM FROM REAR	DIM FROM FRONT (24\"/>	
ND-2 (-W) Exhaust only	4.125"	2.25"	2.25"
VHB (-B)	2.25"	2.25"	2.25"

ALL OTHER HOOD MODELS CONTACT CAPTIVE AIRE FOR HANGING ANGLE LOCATIONS

HANGING ANGLE LOCATIONS

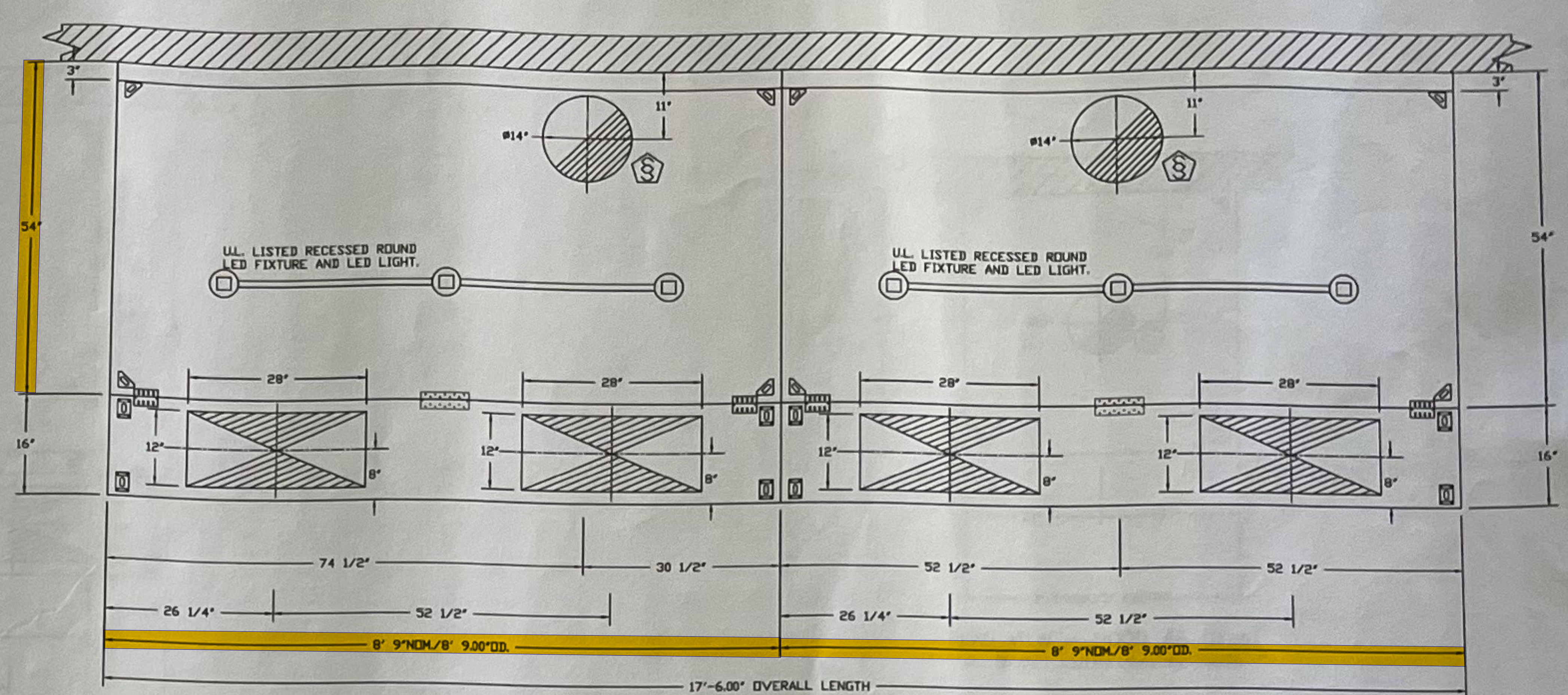

PLAN VIEW - HOOD #1 (15)
 8' 9.00" LONG 5424ND-2-PSP-F

PLAN VIEW - HOOD #2 (15)
 8' 9.00" LONG 5424ND-2-PSP-F

HOOD INFORMATION - JOB#5909715

HOOD NO	TAG	MODEL	MANUFACTURER	LENGTH	MAX COOKING TEMP	TYPE	APPLIANCE DUTY	DESIGN CFM/FT	TOTAL EXH CFM	EXHAUST PLENUM RISER(S)				TOTAL SUPPLY CFM	HOOD CONSTRUCTION	HOOD CONFIG	
										WIDTH	LENG	HEIGHT	DIA				
1	15	5424 ND-2-PSP-F	CAPTIVEAIRE	8' 9"	600 DEG	I	HEAVY	240	2100	4'	14'	2100	1964	-0.948"	1619	430 SS WHERE EXPOSED	LEFT ALONE
2	15	5424 ND-2-PSP-F	CAPTIVEAIRE	8' 9"	600 DEG	I	HEAVY	240	2100	4'	14'	2100	1964	-0.948"	1619	430 SS WHERE EXPOSED	RIGHT ALONE
3	16	6024 ND-2-PSP-F	CAPTIVEAIRE	6' 11"	600 DEG	I	HEAVY	275	1902	4'	14'	1902	1779	-0.954"	1314	430 SS WHERE EXPOSED	ALONE ALONE
4	Dish	4224 VHB-G	CAPTIVEAIRE	3' 6"	700 DEG	II	N/A	150	525	4'	10'	525	963	-0.069"	0	430 SS 100%	ALONE ALONE

HOOD INFORMATION

HOOD NO	TAG	FILTER(S)			EFFICIENCY @ 7 MICRONS	QTY	LIGHT(S)		UTILITY CABINET(S)				FIRE SYSTEM	HOOD HANGING WEIGHT	
		TYPE	QTY	HEIGHT			LENGTH	TYPE	WIRE GUARD	LOCATION	SIZE	TYPE			SIZE
1	15	CAPTRATE SOLO FILTER	6	20"	16"	85% SEE FILTER SPEC	3	RECESSED ROUND	NO					YES	462 LBS
2	15	CAPTRATE SOLO FILTER	6	20"	16"	85% SEE FILTER SPEC	3	RECESSED ROUND	NO					YES	462 LBS
3	16	CAPTRATE SOLO FILTER	5	20"	16"	85% SEE FILTER SPEC	2	RECESSED ROUND	NO	RIGHT	12"x60"x24"	TANK FS	4.0/4.0/4.0/4.0		899 LBS
4	Dish						0							NO	135 LBS

HOOD OPTIONS

HOOD NO	TAG	OPTION
3	16	LEFT END STANDOFF (FINISHED) 1" WIDE 60" LONG INSULATED.

PERFORATED SUPPLY PLENUM(S)

HOOD NO	TAG	POS	LENGTH	WIDTH	HEIGHT	TYPE	RISER(S)			
							WIDTH	LENG	DIA	CFM
1	15	Front	105'	16'	6'	MUA	12"	28"	809	0.243"
						MUA	12"	28"	809	0.243"
2	15	Front	105'	16'	6'	MUA	12"	28"	809	0.243"
						MUA	12"	28"	809	0.243"
3	16	Front	96'	16'	6'	MUA	12"	28"	657	0.165"
						MUA	12"	28"	657	0.165"

These products and others are available for demonstration at the Northern CA display center --For more information or questions Contact--
 Captive Aire Systems
 1110 Burnett Ave, Suite G, Concord, CA 94520
 Phone: (925)962-1999, Fax: (925)566-8565
 Email: reg92@captiveaire.com

FOR REFERENCE ONLY, DESIGNED BY OTHERS

REVISIONS

NO.	DESCRIPTION

CAPTIVE AIRE

Pippal - Emeryville 3-17-23

DATE: 5
 DRAWN BY: 3/
 MAST
 S

