



Our Passion is Building®

Submittal Record

Rodgers Builders, Inc.
PO Box 18446 (28218)
5701 North Sharon Amity Road
Charlotte, NC 28215

rodgersbuilders.com
704 537 6044 TELEPHONE
704 535 0055 FAX

Architect:

Project:

Rodgers Project #:

Form of Submittal

Submittal No.

- Product Data
- Shop Drawings
- Mix Designs
- MSDS Sheets
- Physical Samples
- Manufacturer's Certification
- Test Reports
- Installation Instructions
- Letter of Affidavit / Compliance
- Welding Certificates
- Sample Warranty
- Other (Specify) - _____

Item: _____

Drawing Number: _____

Spec. Section & Package No.: _____

Manufacturer: _____

Brand: _____

Submitted By: _____

Review Due Date: _____

P-1 PAGE 4
P-2 PAGE 12
P-3,4 PAGE 20
P-5,6 PAGE 29
P-7 PAGE 38
P-8 PAGE 41

- NO EXCEPTIONS TAKEN
- EXCEPTIONS INDICATED
- REVISE AND RESUBMIT
- REJECTED; RESUBMIT

REVIEWED ONLY FOR CONFORMANCE WITH DESIGN CONCEPT OF THE PROJECT AND COMPLIANCE WITH INFORMATION GIVEN IN THE CONTRACT DOCUMENTS. THE CONTRACTOR IS RESPONSIBLE FOR DIMENSIONS TO BE VERIFIED AND CORRELATED AT THE SITE; FOR QUANTITY VERIFICATION; FOR INFORMATION THAT PERTAINS SOLELY TO THE FABRICATION PROCESSES OR THE MEANS, METHODS, TECHNIQUES OR SEQUENCES AND PROCEDURES OF CONSTRUCTION; AND FOR COORDINATION OF THE WORK OF ALL TRADES.

YATES-CHREITZBERG-HUGHES ARCHITECTS
7035 NORTHWINDS DR. NW
CONCORD, NORTH CAROLINA 28027

BY: JRS DATE: 02/07/2025

PER OPTIMA

Rodgers Stamp

Rodgers Builders, Inc.

- ___ No Exception Taken ___ Make Corrections Noted
- ___ Rejected ___ Revise and Resubmit
- ___ Submit Specified Item ___ Reviewed

Corrections and comments are only for general conformance with the design concepts of the project and general compliance with the information given in the contract documents. Action shown is subject to the requirements of the plans and specifications. This review does not relieve the subcontractor/vendor from compliance with requirements of the drawings and specifications. Subcontractor /vendor is responsible for dimensions which shall be confirmed and correlated at the job site, fabrication process, and techniques of construction: coordination of their work with that of all other trades and the satisfactory performance of their work.

By _____ Date _____
 No. _____

A/E Stamp

OPTIMA ENGINEERING, P.A. SHOP DRAWING REVIEW

REVIEW IS FOR GENERAL COMPLIANCE WITH THE INTENT OF THE CONTRACT DOCUMENTS. MECHANICAL CONTRACTOR SHALL ASSUME RESPONSIBILITY FOR CORRECTNESS, DIMENSIONS, DETAILS, QUANTITIES AND ALL COST ASSOCIATED WITH SUBSTITUTED EQUIPMENT, INCLUDING ELECTRICAL CHANGES, MAINTENANCE ACCESS, CLEARANCES, BUILDING ALTERATIONS, PIPING, REPLACEMENT OF OTHER SYSTEM COMPONENTS, ETC.

NO EXCEPTION TAKEN	
APPROVED AS NOTED	X
REVISE AND RESUBMIT	
REJECTED	

Reviewed By: Kelsey Sheehan

Date: 01/28/2025

OPTIMA: SEE NOTES THROUGHOUT



PUMPS & AIR CONTROL SUBMITTAL DATA

FOR

Coltrane-Webb / Beverly Hills Replacement Elementary School

61 Spring St. NW, Concord, NC 28025

Owner: Cabarrus County Schools
Mechanical Engineer: Optima Engineering
Mechanical Contractor: Superior Mechanical

Date: 1/22/2025
Revision: 0
Submitted By: Adam Parker
Equipment Manufacturers: Armstrong, American Wheatley, Twin City Hose
Equipment Types: Pumps, Expansion Tanks, Air Separators, Chemical Shot Feeders, Flex Connectors
Specification Section: 23 21 23 – Hydronic Pumps
Unit Tags: P-1 through P-8
Estimated Leadtime: 8-10 Weeks



Submittal Scope PUMPS & AIR CONTROL

To: Superior Mechanical
Attn: Ben Wyke

Date: January 22, 2025

Project Name: **Coltrane-Webb/Beverly Hills Elementary**
Concord, NC

Engineer: Optima Engineering
Charlotte, NC

Description

Armstrong Pumps

(QTY. 1) Base Mounted End Suction Pump – **Tagged: P-1**

Model 4030, 3x1.5x6, 80 USgpm @ 33 ft, 1.5 hp Motor (460/3), Single with Suction Guide and Flo-Trex Valve

(QTY. 1) Base Mounted End Suction Pump – **Tagged: P-2**

Model 4030, 4x3x8, 320 USgpm @ 37 ft, 5 hp Motor (460/3), Single with Suction Guide and Flo-Trex Valve

(QTY. 2) Variable Speed Base Mounted End Suction Pump – **Tagged: P-3, -4**

Model 4030, 3x2x10, 400 USgpm @ 65 ft, 7.5 hp Motor (460/3), Parallel with Suction Guide and Flo-Trex Valve

(QTY. 2) Variable Speed Base Mounted End Suction Pump – **Tagged: P-5, -6**

Model 4030, 1.5x1x8, 100 USgpm @ 64 ft, 3 hp Motor (460/3), Parallel with Suction Guide and Flo-Trex Valve

(QTY. 2) Close Coupled Vertical Inline Pump – **Tagged: P-7, P-8**

Model 4380, 1.5x1.5x6, 100 USgpm @ 25 ft, 0.75 hp Motor (120/1)

P-1 thru P-8 Notes & Exclusions:

10-year parts/5-year labor warranty not included.

VFD's for P-3, P-4, P-5, and P-6 are Yaskawa drives, shipped loose for field installation by others.

Freight to jobsite included. No labor, startup, wiring, training, or any accessory not listed above included.

P-1 scheduled efficiency of 72% is not met by proposed Armstrong pump (65.5%)

P-2 scheduled efficiency of 85% is not met by proposed Armstrong pump (69%)

All other proposed pumps meet or exceed respective scheduled efficiency.

Air Control Equipment & Accessories

(QTY. 1) Armstrong Model VA-3-UM Vortex Air Separator, with strainer, ASME, 160 PSI

(QTY. 1) Armstrong Model VA-6-UM Vortex Air Separator, with strainer, ASME, 160 PSI

(QTY. 1) Armstrong Model A800-L 30" Bladder Type Expansion Tanks, ASME, 125psi

(QTY. 1) Armstrong Model A500-L 24" Bladder Type Expansion Tanks, ASME, 125psi

(QTY. 2) American Wheatley Chemical Shot Feeders

(QTY. 8) Stainless Steel Flex Connectors w/ Carbon Steel Flange End Fittings

Submittal

Ref. #: SQJPE006360_1

long-coupled horizontal base-mounted end suction pump

Model: Series 4030 - 3x1.5x6 - 4p - 1.5 hp - (Factory Choice Motor) with Suction Guide and Flo-Trex Valve

Project name:	Representative: Sam Braddock
Location:	Phone number:
Date submitted: 1/16/2025 9:34 PM	e-mail: sbraddock@insightusa.com
Engineer:	Submitted by: Braddock, Sam

Application design data

Tag number: P-1	Piping configuration: Single
Service: Chiller #1	Suction pressure: 0 ft
Equipment Location:	Fluid: Non-Potable Fluid - Water
Qty: 1	Operating temperature: 60 °F
Total system flow: 80 USgpm	Duty flow per pump: 80 USgpm
System head: 33 ft	Viscosity: 31 SSU
Total dissolved solids: 0 ppm	Specific gravity: 1.0000
NPSHR: 4.4 ft	Absorbed Power/BHP: 1.02 hp
%Mtr Safety*: 40.2%	Efficiency at Design: 65.48 %
Outlet velocity: 12.61 ft/s	Impeller diameter: 6.19 in
PEIcl: 0.53	ERcl: 47
Standby qty: 0	Pump/motor run qty: 1
Load Profile Location: NA	Building Type: NA
Climate Zone Type: NA	Time Period: 8760 (1 Year)

*Motor safety factor above duty point.

Materials of construction

Construction: Bronze Fitted	Impeller: Bronze
Rating: ANSI-125	Pump shaft: Carbon Steel
Connections: Inlet: 3 in, Outlet: 1.5 in	Shaft sleeve:ea 304 SS
Casing (volute): Cast Iron, E-coated	Flexible coupling: Duraflex coupling
Bearings: Anti-Friction Grease Lubricated	Casing gasket: Confined Non-Asbestos Fiber
Drip pan: No	

Mechanical seal data

Seal type: Inside Single Spring	Rotating face: Resin Bonded Carbon
Manufacturer code: C-ssc L EPSS 2A	Stationary seat: Sintered Silicon Carbide
Springs: Stainless Steel	Secondary seal: EPDM
Rotating hardware: Stainless Steel	Maximum total dissolved solids (TDS)*: 2000 PPM

*Note: Please ensure proper seal is selected by inputting Total Dissolved Solids (TDS) in PPM in ADEPT if water quality is poor at site. Also select Flush Line Filter or Cyclone Separator if there are other contaminants in the fluid.

Electrical data

Supplier: Factory Choice	Insulation class: Class F Insulation
Frame size: 145TC	Motor type: Inverter Duty
Speed: 1673 rpm	Size: 1.5 hp
Enclosure: ODP	Efficiency: NEMA Premium 12.12
Power supply: 460/3/60	

Operating limits (temperature - pressure)

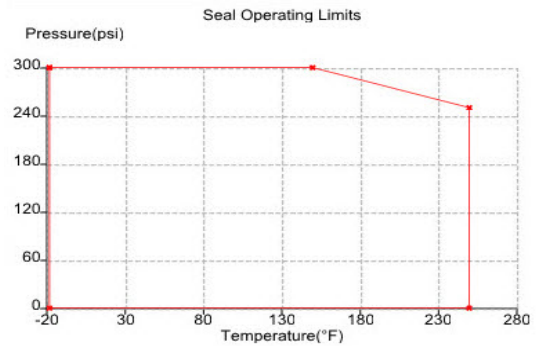
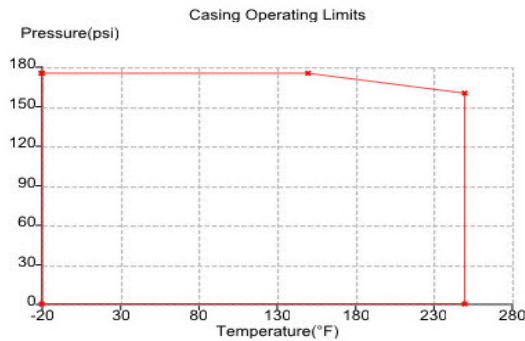

Maximum pressure: 175 psi

Maximum temperature: 250 F

All Pump casings are hydrostatically tested to requirements of ANSI/HI 14.6 standard.

Performance curve

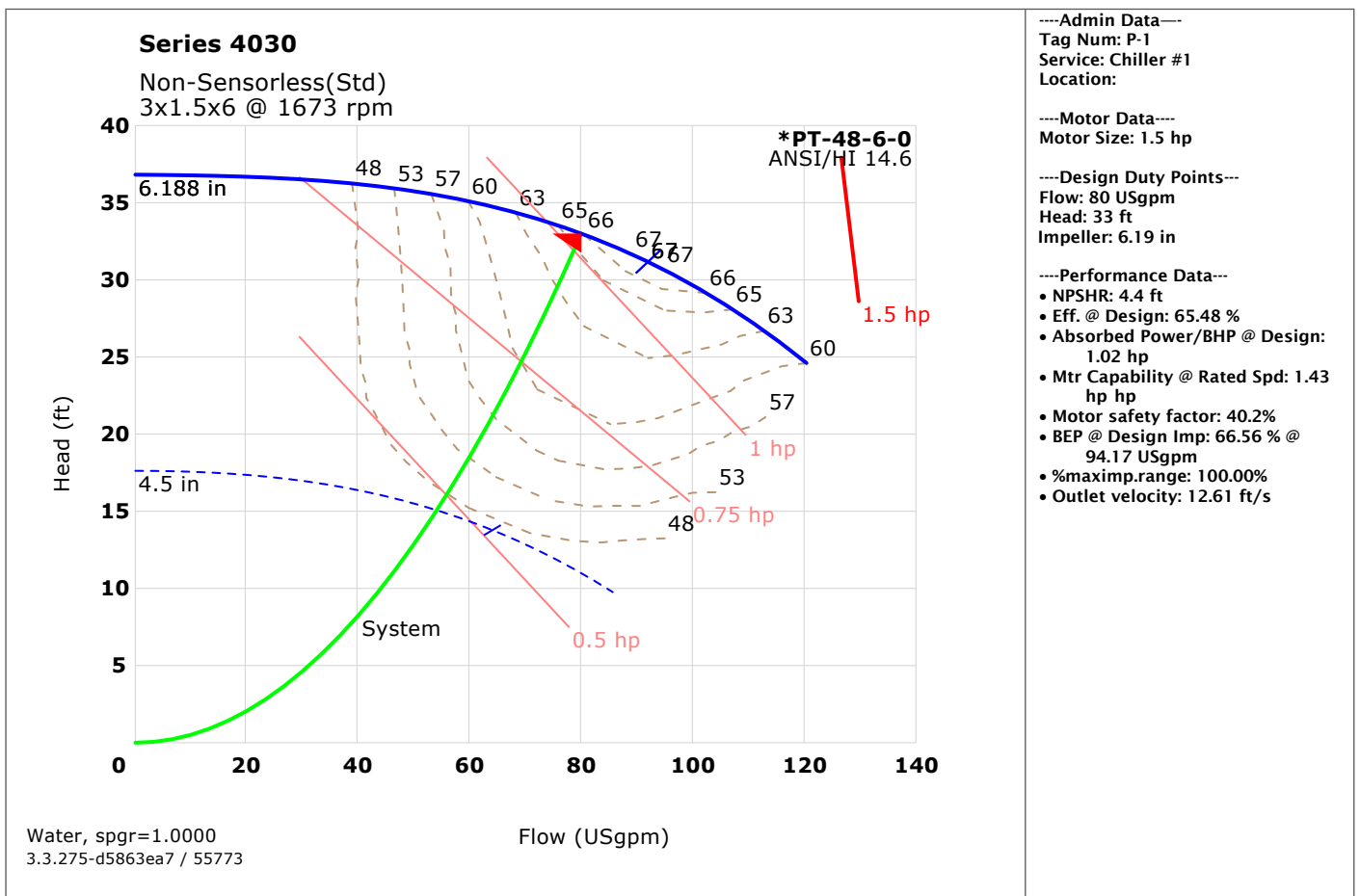

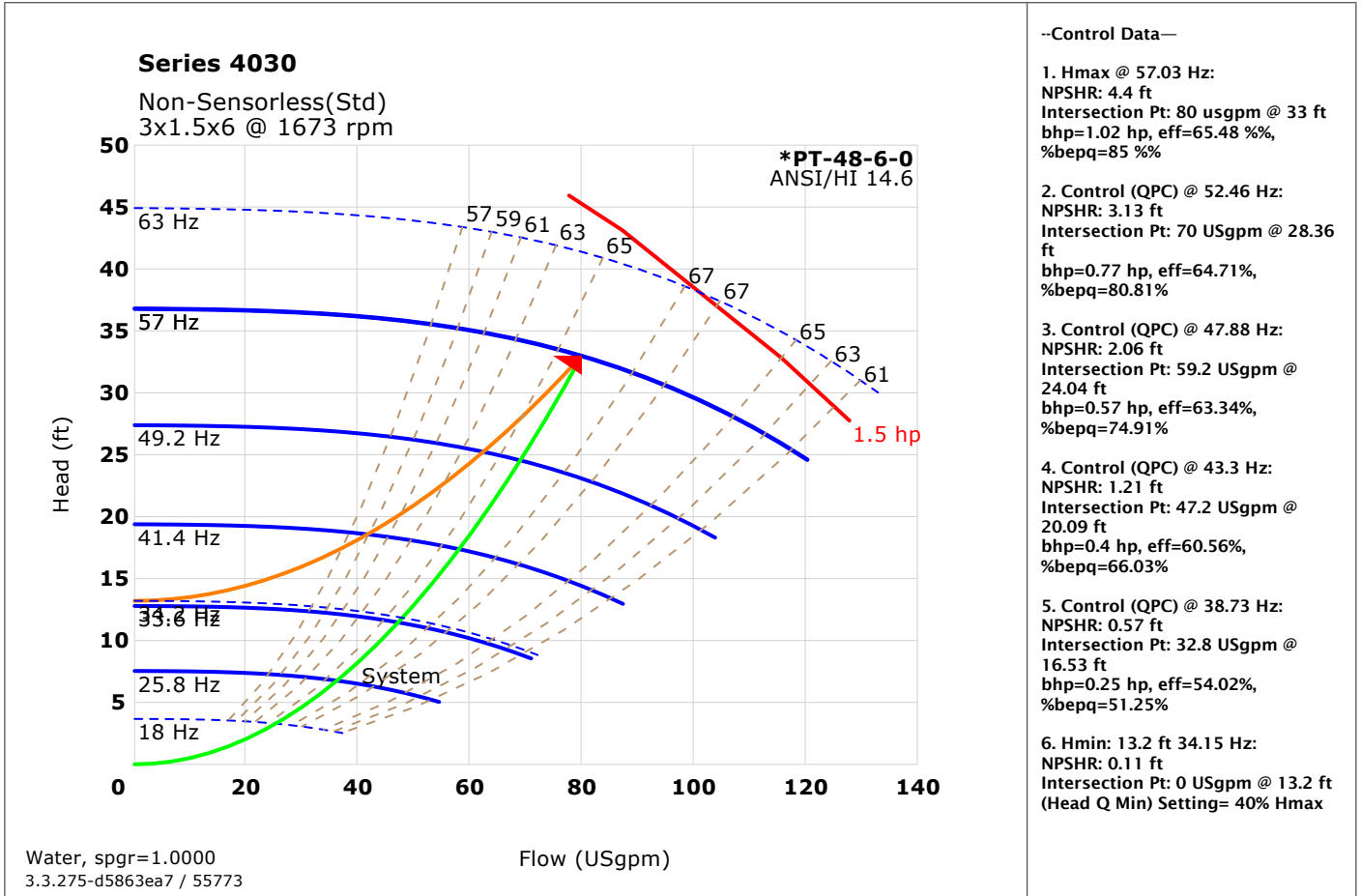

Dimensional data (not for construction)

Side view

Top view

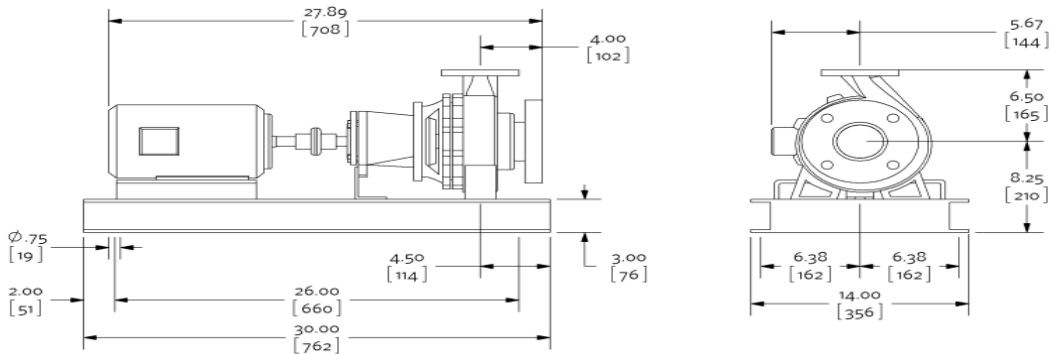

Inverter motor type: Inverter duty

Weight: 160 lb [72.57 kg], Units of measure: inches [millimeters]

- Not to scale
- Tolerance of ± 0.125 inch (± 3 mm) should be used
- For certified dimensions, please contact your Armstrong representative
- Pump equipped with casing drain plug and ¼ inch NPT suction and discharge gauge ports

Connection details

Connection	Size	Rating	OD	Bolt quantity*	BCD	Bolt size
Inlet	3	ANSI-125	7.50	4	6.00	0.625
Outlet	1.5	ANSI-125	5.00	4	3.88	0.5

*Equally spaced straddling centreline

Special instructions

Reference Motor Specification AES 05007.

The program has defaulted to a NEMA Premium Efficiency motor supplied with NEMA MG-1 Part 31.4.4.2 insulation standards for inverter-fed polyphase motors.

Selected options

Testing: No Test Certification Required

Seal Environment Accessories: None

VFD Disconnect: Integrated Fused Disconnect

Couplings: Duraflex coupling

Space Heater: No

Motor Thermistor: No Thermistors

Wye-Delta Starting: No

Drip Pan: No

Bearing Current Handling: AEGIS Shaft Ground

Submittal

Ref. #: SQJPE006360_1

Suction guide

Model: SG-43

Project name:	Representative:	Sam Braddock
Location:	Phone number:	
Date submitted: 1/16/2025 9:34 PM	e-mail:	sbraddock@insightusa.com
Engineer:	Submitted by:	Braddock, Sam

Application design data

Tag	Qty	Model	Pipe Conn.size	Pump Conn.size	Design flowrate	Pressure Drop*	Associated pump
P-1	1	SG-43	4 in	3 in	80 USgpm	0.27 ft	4030 - 3x1.5x6 - 4p - 1.5 hp - (Factory Choice Motor)

*at design flow

Materials of construction

SG-43

Body:	Cast iron	Cover gasket:	Synthetic fiber
Guide vanes:	Cast iron	Strainer:	Stainless Steel,0.125"(3mm)Perf..
Cover plate:	Cast iron	Start-up strainer*:	Fine Mesh Galvanized Steel

*Remove start up strainer after 24 hours of pump operation

Operating limits (temperature - pressure)

SG-43-Suction Guide-ANSI-125

PRESSURE TEMPERATURE LIMITS

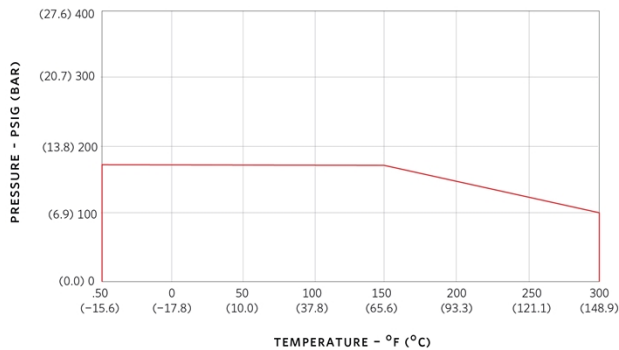

Maximum pressure: 175 psi
Maximum temperature: 300 F

Units are hydrostatically tested to 150% of maximum working pressure

Dimensional data (not for construction)

SG-43

Weight: 52 lb [23.59 kg]

Side view

Top view

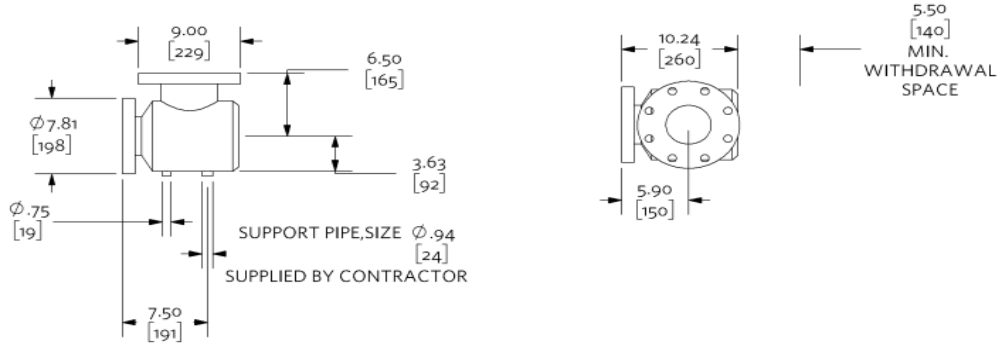

Not to scale

Units of measure: inches [millimeters]

Tolerance of +/- 0.125 inch (+/- 3 mm) should be used

For certified dimensions, please contact your Armstrong representative

Submittal

Ref. #: SQJPE006360_1

Flo-trex valve

Model: FTV-2.5FS-Flo-Trex Valve-ANSI-125-Straight

Project name:	Representative:	Sam Braddock
Location:	Phone number:	
Date submitted: 1/16/2025 9:34 PM	e-mail:	sbraddock@insightusa.com
Engineer:	Submitted by:	Braddock, Sam

Application design data

Tag	Qty	Model	Size Inlet/Outlet	Config	Pipe Type	Design flowrate	Pressure Drop*	Associated pump
P-1	1	FTV-2.5FS	2.5 in	Straight	Flanged	80 USgpm	3.62 ft	4030 - 3x1.5x6 - 4p - 1.5 hp - (Factory Choice Motor)

*at design flow

Materials of construction

FTV-2.5FS-Flo-Trex Valve-ANSI-125-Straight

Body:	Cast Iron	Spring:	304 Stainless Steel
Disc:	EPDM	O rings:	EPDM
Seat:	Cast Bronze	2 metering ports:	Brass
Stem:	304 Stainless Steel	2 drain tappings:	Not Applicable

Operating limits (temperature - pressure)

FTV-2.5FS-Flo-Trex Valve-ANSI-125-Straight

PRESSURE TEMPERATURE LIMITS

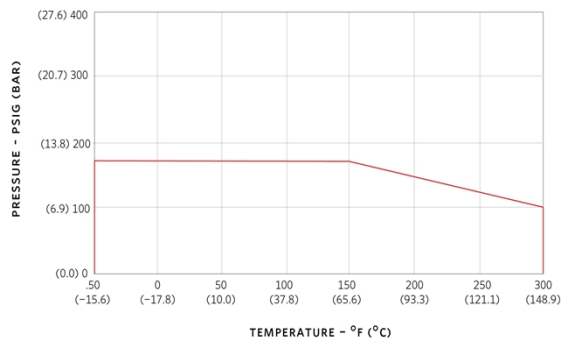

Maximum pressure: 175 psi
Maximum temperature: 300 F

Dimensional data (not for construction)

Model: FTV-2.5FS-Flo-Trex Valve-ANSI-125-Straight

Weight: 33 lb [14.97 kg]

Side view

Front view

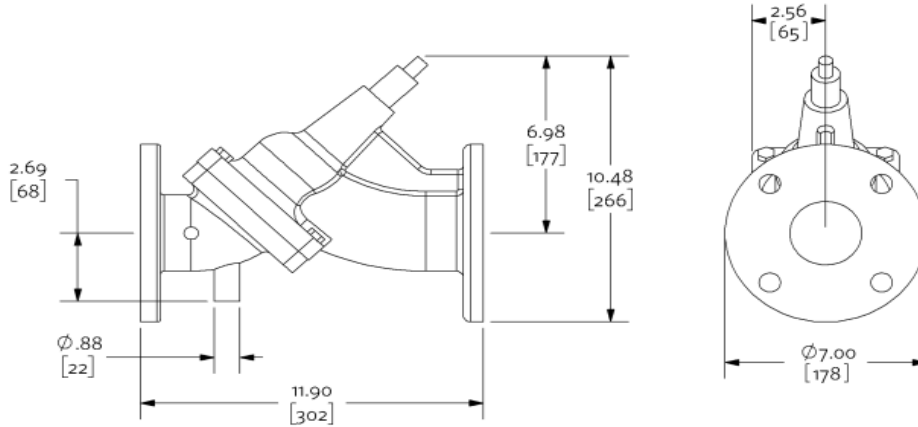

Not to scale

Units of measure: inches [millimeters]

Tolerance of +/- 0.125 inch (+/- 3 mm) should be used

For certified dimensions, please contact your Armstrong representative

Submittal

Ref. #: SQJPE006360_1

long-coupled horizontal base-mounted end suction pump

Model: Series 4030 - 4x3x8 - 4p - 5 hp - (Factory Choice Motor) with Suction Guide and Flo-Trex Valve

Project name:	Representative:	Sam Braddock
Location:	Phone number:	
Date submitted: 1/16/2025 9:34 PM	e-mail:	sbraddock@insightusa.com
Engineer:	Submitted by:	Braddock, Sam

Application design data

Tag number: P-2	Piping configuration: Single
Service: Chiller #2	Suction pressure: 0 ft
Equipment Location:	Fluid: Non-Potable Fluid - Water
Qty: 1	Operating temperature: P-1 PAGE 4
Total system flow: 320 USgpm	Duty flow per pump: P-2 PAGE 12
System head: 37 ft	Viscosity: 31 SSU
Total dissolved solids: 0 ppm	Specific gravity: 1.0000
NPSHR: 13.38 ft	Absorbed Power/BHP: 4.34 hp
%Mtr Safety*: 13.59%	Efficiency at Design: 68.96 %
Outlet velocity: 13.89 ft/s	Impeller diameter: 7.66 in
PEIcl: 0.47	ERcl: 53
Standby qty: 0	Pump/motor run qty: 1
Load Profile Location: NA	Building Type: NA
Climate Zone Type: NA	Time Period: 8760 (1 Year)

*Motor safety factor above duty point.

Materials of construction

Construction: Bronze Fitted	Impeller: Bronze
Rating: ANSI-125	Pump shaft: Carbon Steel
Connections: Inlet: 4 in, Outlet: 3 in	Shaft sleeve:ea 304 SS
Casing (volute): Cast Iron, E-coated	Flexible coupling: Duraflex coupling
Bearings: Anti-Friction Grease Lubricated	Casing gasket: Confined Non-Asbestos Fiber
Drip pan: No	

Mechanical seal data

Seal type: Inside Single Spring	Rotating face: Resin Bonded Carbon
Manufacturer code: C-ssc L EPSS 2A	Stationary seat: Sintered Silicon Carbide
Springs: Stainless Steel	Secondary seal: EPDM
Rotating hardware: Stainless Steel	Maximum total dissolved solids (TDS)*: 2000 PPM

*Note: Please ensure proper seal is selected by inputting Total Dissolved Solids (TDS) in PPM in ADEPT if water quality is poor at site. Also select Flush Line Filter or Cyclone Separator if there are other contaminants in the fluid.

Electrical data

Supplier: Factory Choice	Insulation class: Class F Insulation
Frame size: 184TC	Motor type: Inverter Duty
Speed: 1741 rpm	Size: 5 hp
Enclosure: ODP	Efficiency: NEMA Premium 12.12
Power supply: 460/3/60	

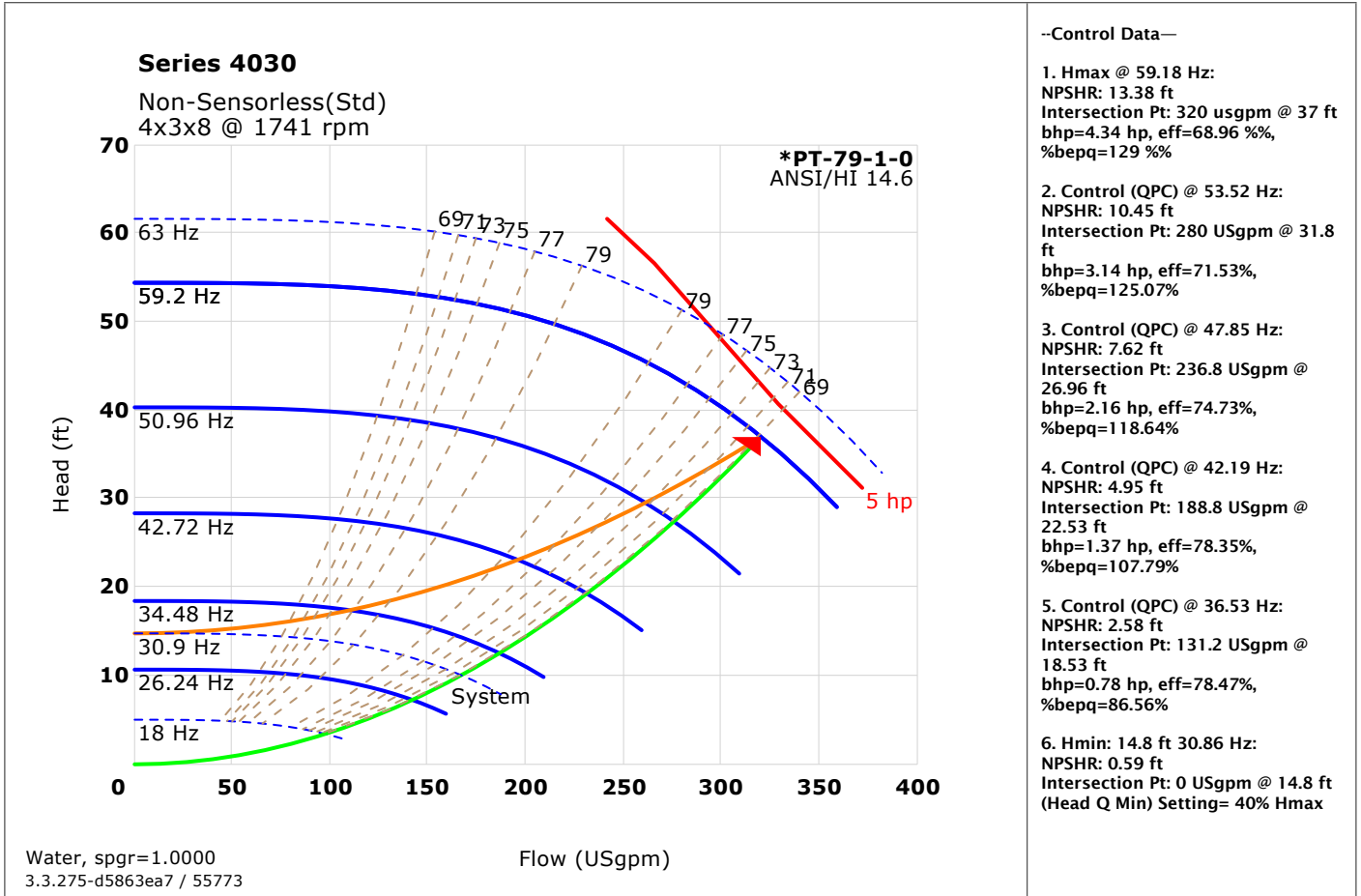

Dimensional data (not for construction)

Side view

Top view

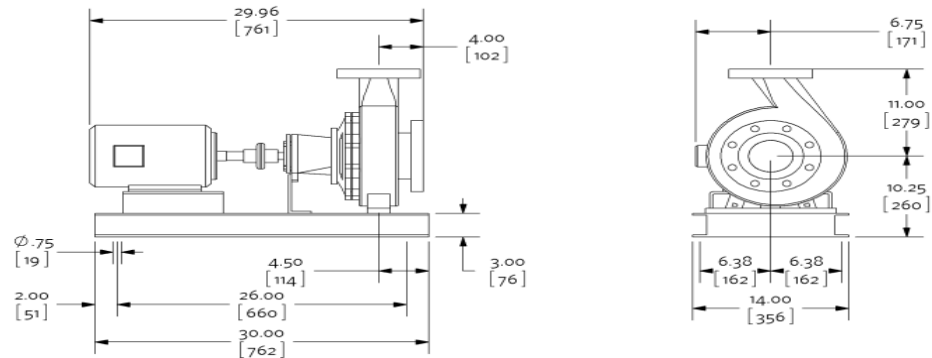

Inverter motor type: Inverter duty

Weight: 264 lb [119.75 kg], Units of measure: inches [millimeters]

- Not to scale
- Tolerance of ± 0.125 inch (± 3 mm) should be used
- For certified dimensions, please contact your Armstrong representative
- Pump equipped with casing drain plug and ¼ inch NPT suction and discharge gauge ports

Connection details

Connection	Size	Rating	OD	Bolt quantity*	BCD	Bolt size
Inlet	4	ANSI-125	9.00	8	7.50	0.625
Outlet	3	ANSI-125	7.50	4	6.00	0.625

*Equally spaced straddling centreline

Special instructions

Reference Motor Specification AES 05007.

The program has defaulted to a NEMA Premium Efficiency motor supplied with NEMA MG-1 Part 31.4.4.2 insulation standards for inverter-fed polyphase motors.

Selected options

Testing: No Test Certification Required

Seal Environment Accessories: None

VFD Disconnect: Integrated Fused Disconnect

Couplings: Duraflex coupling

Space Heater: No

Motor Thermistor: No Thermistors

Wye-Delta Starting: No

Drip Pan: No

Bearing Current Handling: AEGIS Shaft Ground

OPTIMA: P-2 NO
VFD

Submittal

Ref. #: SQJPE006360_1

Suction guide

Model: SG-54

Project name:	Representative: Sam Braddock
Location:	Phone number:
Date submitted: 1/16/2025 9:34 PM	e-mail: sbraddock@insightusa.com
Engineer:	Submitted by: Braddock, Sam

Application design data

Tag	Qty	Model	Pipe Conn.size	Pump Conn.size	Design flowrate	Pressure Drop*	Associated pump
P-2	1	SG-54	5 in	4 in	320 USgpm	1.24 ft	4030 - 4x3x8 - 4p - 5 hp - (Factory Choice Motor)

*at design flow

Materials of construction

SG-54

Body:	Cast iron	Cover gasket:	Synthetic fiber
Guide vanes:	Cast iron	Strainer:	Stainless Steel,0.125"(3mm)Perf..
Cover plate:	Cast iron	Start-up strainer*:	Fine Mesh Galvanized Steel

*Remove start up strainer after 24 hours of pump operation

Operating limits (temperature - pressure)

SG-54-Suction Guide-ANSI-125

PRESSURE TEMPERATURE LIMITS

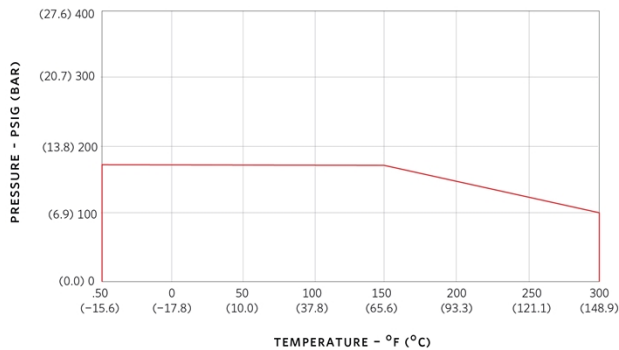

Maximum pressure: 175 psi
Maximum temperature: 300 F

Units are hydrostatically tested to 150% of maximum working pressure

Dimensional data (not for construction)

SG-54

Weight: 79 lb [35.83 kg]

Side view

Top view

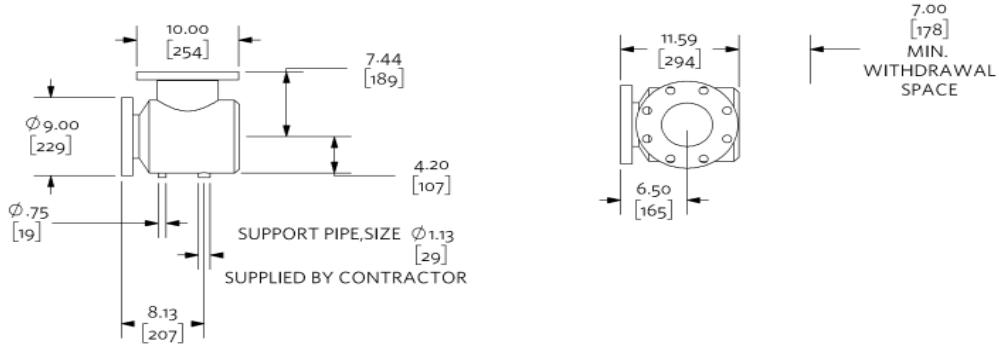

Not to scale

Units of measure: inches [millimeters]

Tolerance of +/- 0.125 inch (+/- 3 mm) should be used

For certified dimensions, please contact your Armstrong representative

Submittal

Ref. #: SQJPE006360_1

Flo-trex valve

Model: FTV-5FS-Flo-Trex Valve-ANSI-125-Straight

Project name:	Representative: Sam Braddock
Location:	Phone number:
Date submitted: 1/16/2025 9:34 PM	e-mail: sbraddock@insightusa.com
Engineer:	Submitted by: Braddock, Sam

Application design data

Tag	Qty	Model	Size Inlet/Outlet	Config	Pipe Type	Design flowrate	Pressure Drop*	Associated pump
P-2	1	FTV-5FS	5 in	Straight	Flanged	320 USgpm	2.8 ft	4030 - 4x3x8 - 4p - 5 hp - (Factory Choice Motor)

*at design flow

Materials of construction

FTV-5FS-Flo-Trex Valve-ANSI-125-Straight

Body:	Cast Iron	Spring:	302 Stainless Steel
Disc:	Brass	O rings:	BUNA N
Seat:	EPDM	2 metering ports:	NPT Brass Body with EPT Check and Gasketed Cap
Stem:	416 Stainless Steel	2 drain tappings:	1/4in with Brass Plug

Operating limits (temperature - pressure)

FTV-5FS-Flo-Trex Valve-ANSI-125-Straight

PRESSURE TEMPERATURE LIMITS

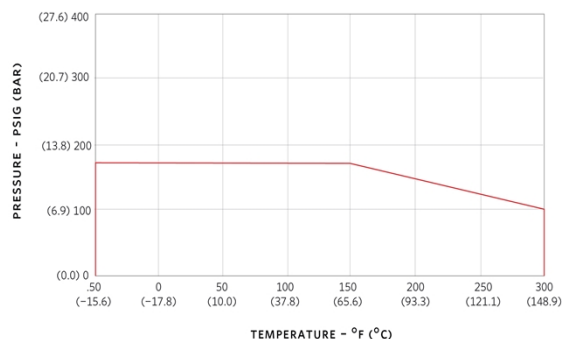

Maximum pressure: 175 psi
Maximum temperature: 300 F



Dimensional data (not for construction)

Model: FTV-5FS-Flo-Trex Valve-ANSI-125-Straight

Weight: 108 lb [48.99 kg]

Side view

Front view

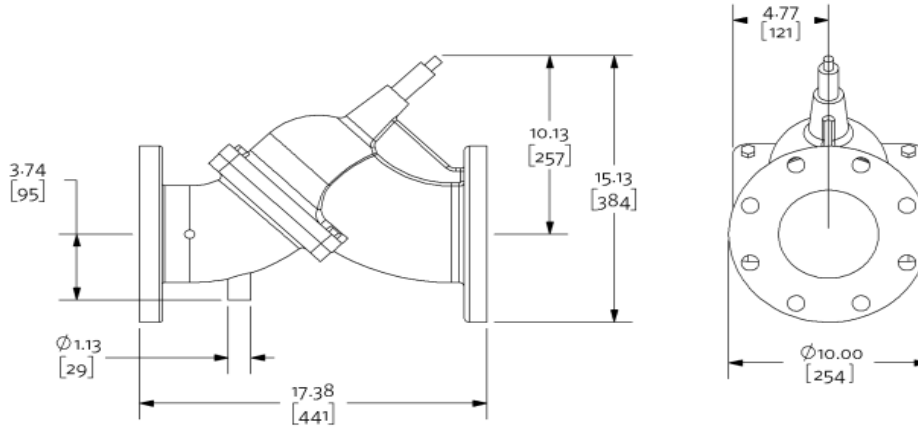

Not to scale

Units of measure: inches [millimeters]

Tolerance of +/- 0.125 inch (+/- 3 mm) should be used

For certified dimensions, please contact your Armstrong representative

Submittal

Ref. #: SQJPE006360_1

Long-Coupled Horizontal Base-Mounted End Suction Pump * Staged by External Controls

Model: Series 4030 - 3x2x10 - 4p - 7.5 hp - (Factory Choice Motor) with Suction Guide and Flo-Trex Valve

Project name:	Representative: Sam Braddock
Location:	Phone number:
Date submitted: 1/16/2025 9:34 PM	e-mail: sbraddock@insightusa.com
Engineer:	Submitted by: Braddock, Sam

Application design data

Tag number: P-3, P-4	Piping configuration: Parallel
Service: Chilled Water Loop	Suction pressure: 0 ft
Equipment Location:	Fluid: Non-Potable Fluid - Water
Qty: 2	Operating temperature: 60 °F
Total system flow: 400 USgpm	Duty flow per pump: 200 USgpm
System head: 65 ft	Viscosity: 31 SSU
Total dissolved solids: 0 ppm	Specific gravity: 1.0000
NPSHR: 8.2 ft	Absorbed Power/BHP: 4.42 hp
%Mtr Safety*: 52.26%	Efficiency at Design: 74.24 %
Outlet velocity: 19.12 ft/s	Impeller diameter: 9.04 in
PEIcl: 0.44	ERcl: 56
Standby qty: 0	Pump/motor run qty: 2
Load Profile Location: NA	Building Type: NA
Climate Zone Type: NA	Time Period: 8760 (1 Year)

*Motor safety factor above duty point.

Materials of construction

Construction: Bronze Fitted	Impeller: Bronze
Rating: ANSI-125	Pump shaft: Carbon Steel
Connections: Inlet: 3 in, Outlet: 2 in	Shaft sleeve:ea 304 SS
Casing (volute): Cast Iron, E-coated	Flexible coupling: Duraflex coupling
Bearings: Anti-Friction Grease Lubricated	Casing gasket: Confined Non-Asbestos Fiber
Drip pan: No	

Mechanical seal data

Seal type: Inside Single Spring	Rotating face: Resin Bonded Carbon
Manufacturer code: C-ssc L EPSS 2A	Stationary seat: Sintered Silicon Carbide
Springs: Stainless Steel	Secondary seal: EPDM
Rotating hardware: Stainless Steel	Maximum total dissolved solids (TDS)*: 2000 PPM

*Note: Please ensure proper seal is selected by inputting Total Dissolved Solids (TDS) in PPM in ADEPT if water quality is poor at site. Also select Flush Line Filter or Cyclone Separator if there are other contaminants in the fluid.

Electrical data

Supplier: Factory Choice	Insulation class: Class F Insulation
Frame size: 213TC	Motor type: Inverter Duty
Speed: 1589 rpm	Size: 7.5 hp
Enclosure: ODP	Efficiency: NEMA Premium 12.12
Power supply: 460/3/60	

OPTIMA: SPEED IS FINE

A/E Confirm speed is acceptable.

Operating limits (temperature - pressure)

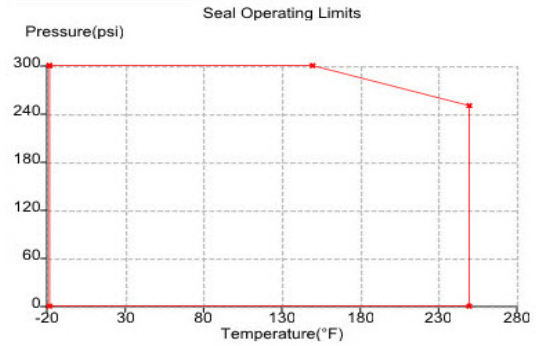
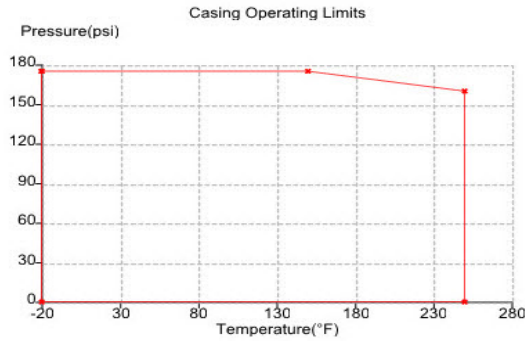

Maximum pressure: 175 psi

Maximum temperature: 250 F

All Pump casings are hydrostatically tested to requirements of ANSI/HI 14.6 standard.

Performance curve

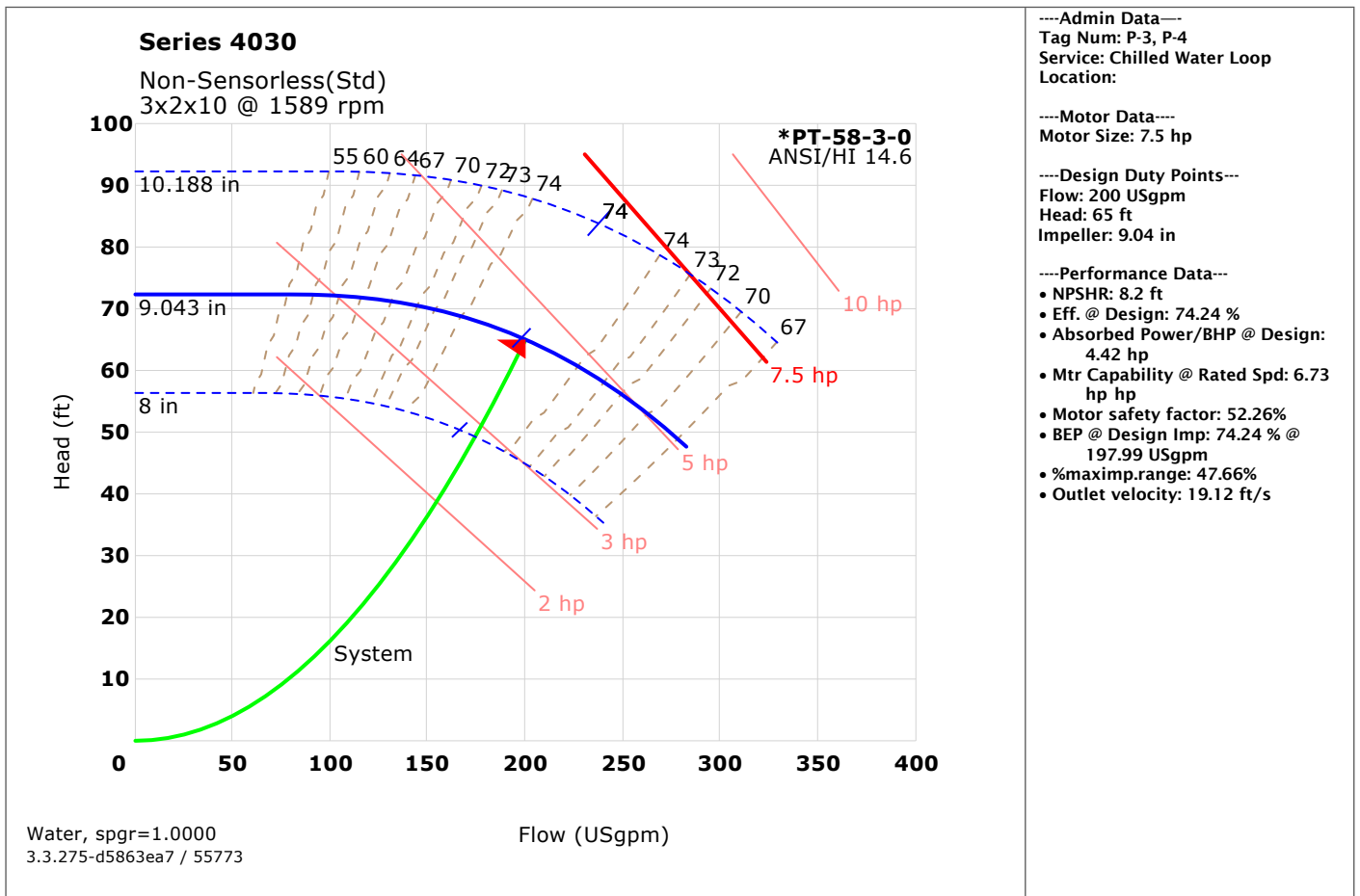

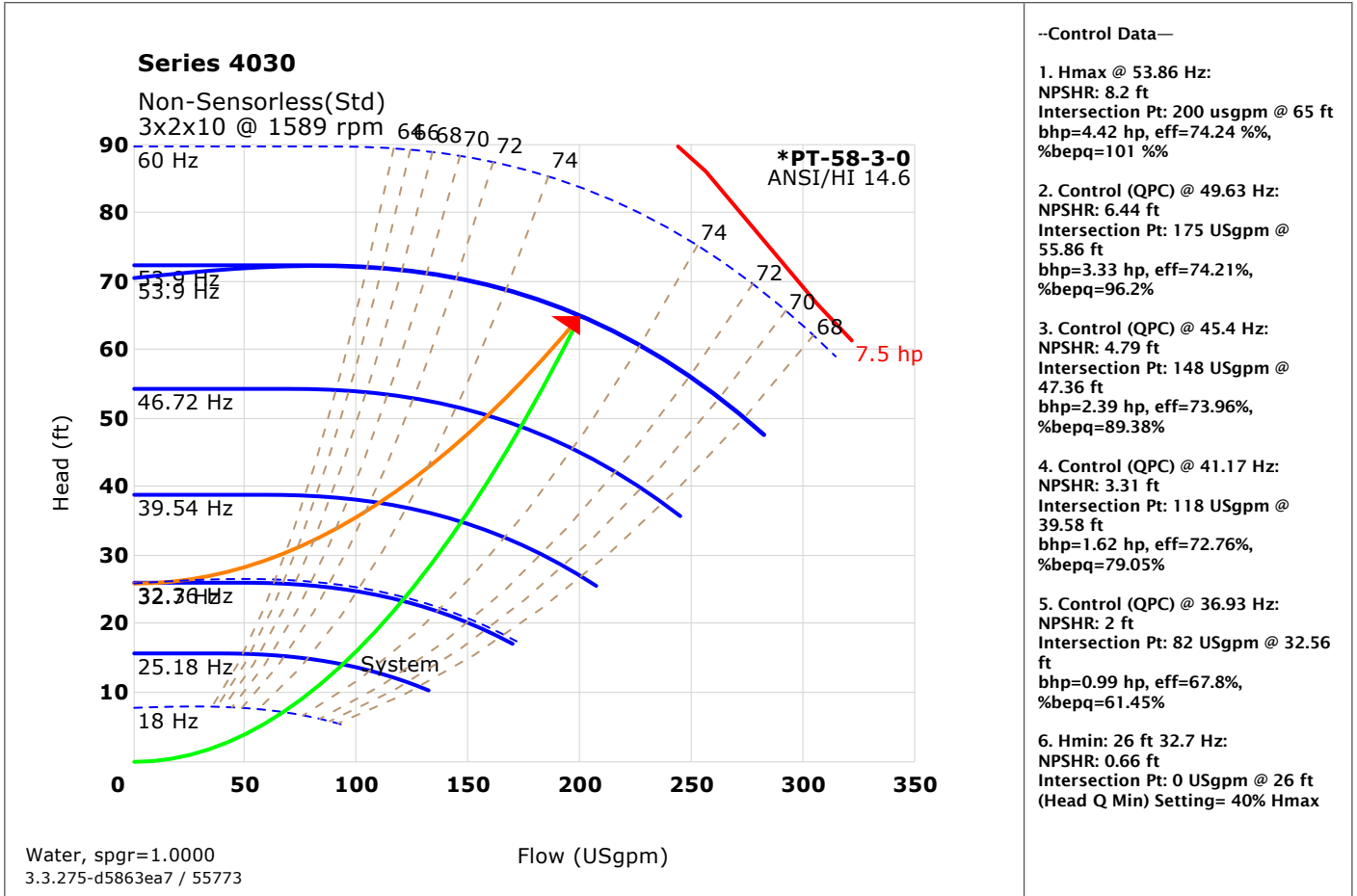

	<p>----Admin Data-- Tag Num: P-3, P-4 Service: Chilled Water Loop Location:</p> <p>----Motor Data---- Motor Size: 7.5 hp</p> <p>----System Design Data-- Piping: Parallel Run Qty: 2 Fluid: Non-Potable Fluid Sp.Gr: 1.0000 ,Vis= 31 SSU Suction: 0 ft Total Design Flow= 400 USgpm Total Design Head= 65 ft</p> <p>---Performance Data--- Total System Flow = 400 USgpm</p>
--	---

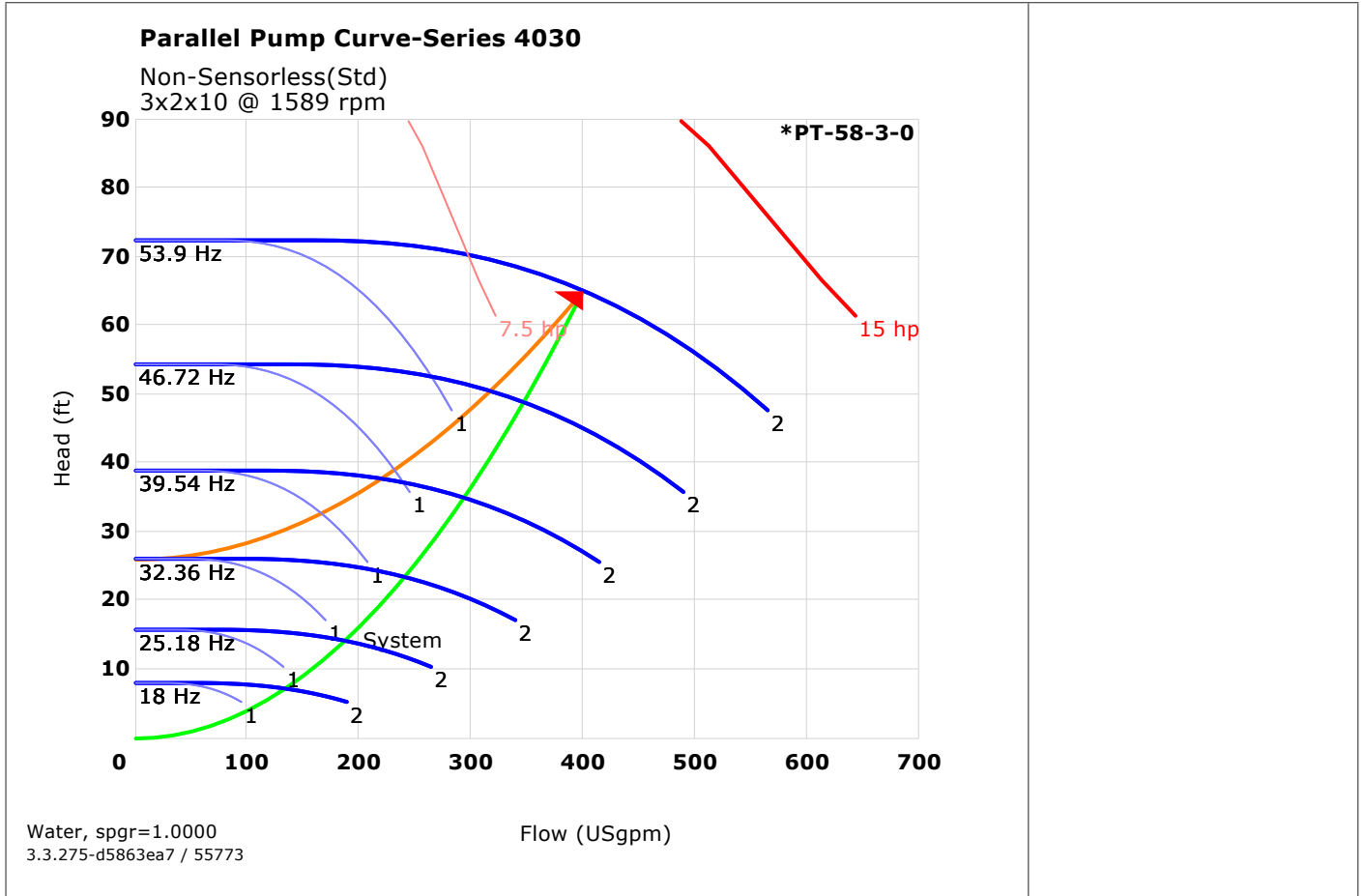

Dimensional data (not for construction)

Side view

Top view

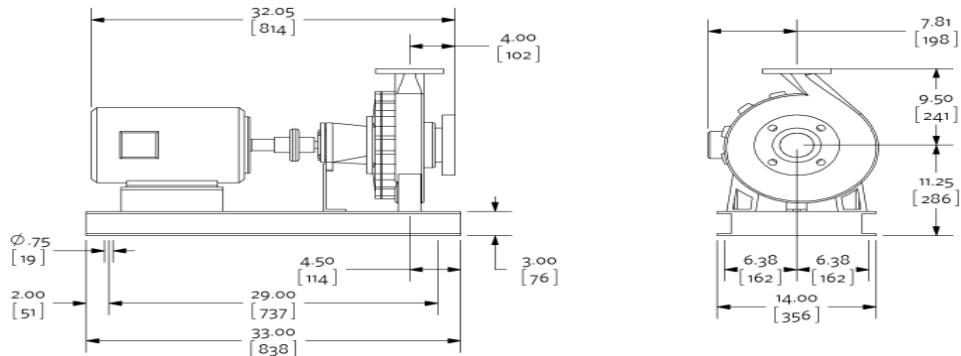

Inverter motor type: Inverter duty

Weight: 305 lb [138.35 kg], Units of measure: inches [millimeters]

- Not to scale
- Tolerance of ± 0.125 inch (± 3 mm) should be used
- For certified dimensions, please contact your Armstrong representative
- Pump equipped with casing drain plug and $\frac{1}{4}$ inch NPT suction and discharge gauge ports

Connection details

Connection	Size	Rating	OD	Bolt quantity*	BCD	Bolt size
------------	------	--------	----	----------------	-----	-----------

Inlet	3	ANSI-125	7.50	4	6.00	0.625
Outlet	2	ANSI-125	6.00	4	4.75	0.625

*Equally spaced straddling centreline

Special instructions

Reference Motor Specification AES 05007.

The program has defaulted to a NEMA Premium Efficiency motor supplied with NEMA MG-1 Part 31.4.4.2 insulation standards for inverter-fed polyphase motors.

Selected options

Testing: No Test Certification Required

Seal Environment Accessories: None

VFD Disconnect: Integrated Fused Disconnect

Couplings: Duraflex coupling

Space Heater: No

Motor Thermistor: No Thermistors

Wye-Delta Starting: No

Drip Pan: No

Bearing Current Handling: AEGIS Shaft Ground

Submittal

Ref. #: SQJPE006360_1

Suction guide

Model: SG-43

Project name:	Representative:	Sam Braddock
Location:	Phone number:	
Date submitted: 1/16/2025 9:34 PM	e-mail:	sbraddock@insightusa.com
Engineer:	Submitted by:	Braddock, Sam

Application design data

Tag	Qty	Model	Pipe Conn.size	Pump Conn.size	Design flowrate	Pressure Drop*	Associated pump
P-3, P-4	2	SG-43	4 in	3 in	200 USgpm	1.68 ft	4030 - 3x2x10 - 4p - 7.5 hp - (Factory Choice Motor)

*at design flow

Materials of construction

SG-43

Body:	Cast iron	Cover gasket:	Synthetic fiber
Guide vanes:	Cast iron	Strainer:	Stainless Steel,0.125"(3mm)Perf..
Cover plate:	Cast iron	Start-up strainer*:	Fine Mesh Galvanized Steel

*Remove start up strainer after 24 hours of pump operation

Operating limits (temperature - pressure)

SG-43-Suction Guide-ANSI-125

PRESSURE TEMPERATURE LIMITS

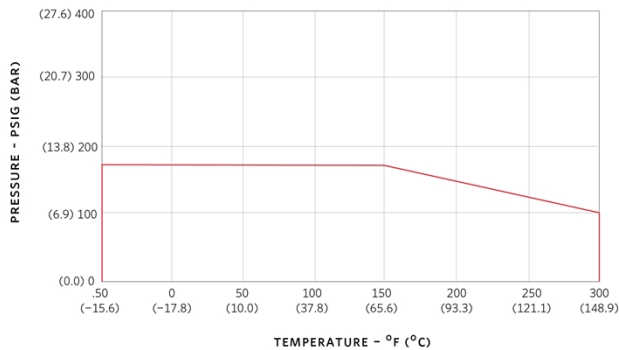

Maximum pressure: 175 psi
Maximum temperature: 300 F

Units are hydrostatically tested to 150% of maximum working pressure

Dimensional data (not for construction)

SG-43

Weight: 52 lb [23.59 kg]

Side view

Top view

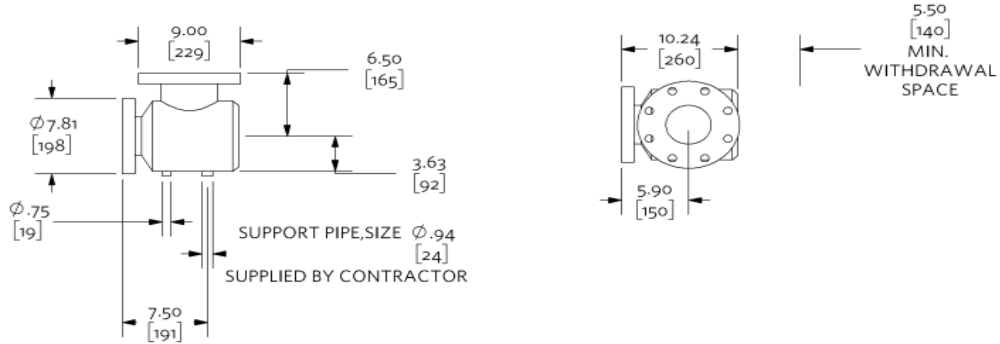

Not to scale

Units of measure: inches [millimeters]

Tolerance of +/- 0.125 inch (+/- 3 mm) should be used

For certified dimensions, please contact your Armstrong representative

Submittal

Ref. #: SQJPE006360_1

Flo-trex valve

Model: FTV-3FS-Flo-Trex Valve-ANSI-125-Straight

Project name:	Representative: Sam Braddock
Location:	Phone number:
Date submitted: 1/16/2025 9:34 PM	e-mail: sbraddock@insightusa.com
Engineer:	Submitted by: Braddock, Sam

Application design data

Tag	Qty	Model	Size Inlet/Outlet	Config	Pipe Type	Design flowrate	Pressure Drop*	Associated pump
P-3, P-4	2	FTV-3FS	3 in	Straight	Flanged	200 USgpm	6.25 ft	4030 - 3x2x10 - 4p - 7.5 hp - (Factory Choice Motor)

*at design flow

Materials of construction

FTV-3FS-Flo-Trex Valve-ANSI-125-Straight

Body:	Cast Iron	Spring:	304 Stainless Steel
Disc:	EPDM	O rings:	EPDM
Seat:	Cast Bronze	2 metering ports:	Brass
Stem:	304 Stainless Steel	2 drain tappings:	Not Applicable

Operating limits (temperature - pressure)

FTV-3FS-Flo-Trex Valve-ANSI-125-Straight

PRESSURE TEMPERATURE LIMITS

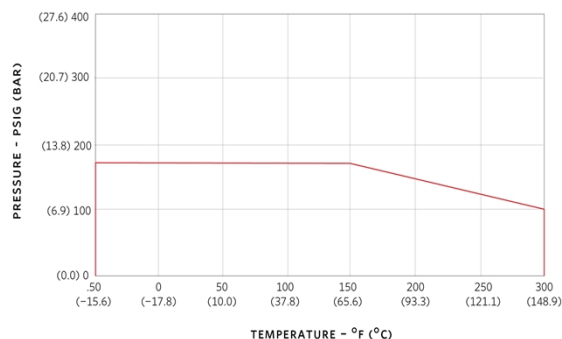

Maximum pressure: 175 psi
Maximum temperature: 300 F

Dimensional data (not for construction)

Model: FTV-3FS-Flo-Trex Valve-ANSI-125-Straight

Weight: 39 lb [17.69 kg]

Side view

Front view

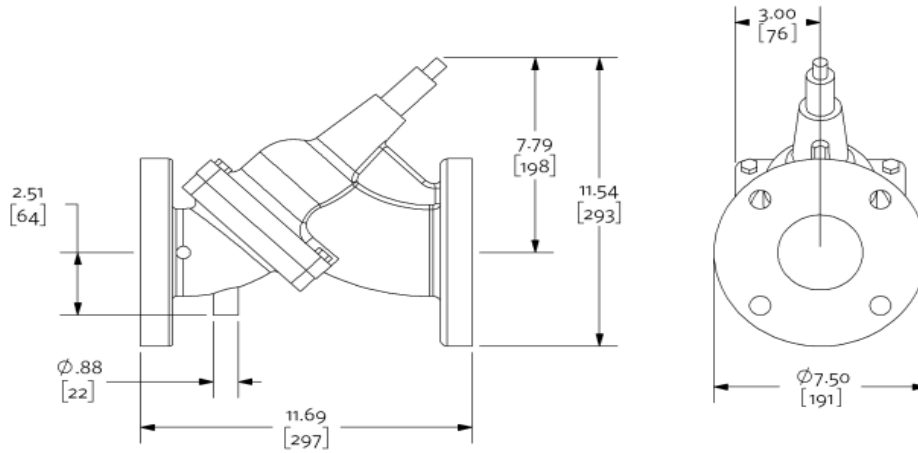

Not to scale

Units of measure: inches [millimeters]

Tolerance of +/- 0.125 inch (+/- 3 mm) should be used

For certified dimensions, please contact your Armstrong representative

Submittal

Ref. #: SQJPE006360_1

Long-Coupled Horizontal Base-Mounted End Suction Pump * Staged by External Controls

Model: Series 4030 - 1.5x1x8 - 4p - 3 hp - (Factory Choice Motor) with Suction Guide and Flo-Trex Valve

Project name:	Representative:	Sam Braddock
Location:	Phone number:	
Date submitted: 1/16/2025 9:34 PM	e-mail:	sbraddock@insightusa.com
Engineer:	Submitted by:	Braddock, Sam

Application design data

Tag number:	P-5, P-6	Piping configuration:	Parallel
Service:	Hot Water Loop	Suction pressure:	0 ft
Equipment Location:		Fluid:	Non-Potable Fluid - Water
Qty:	2	Operating temperature:	60 °F
Total system flow:	100 USgpm	Duty flow per pump:	50 USgpm
System head:	64 ft	Viscosity:	31 SSU
Total dissolved solids:	0 ppm	Specific gravity:	1.0000
NPSHR:	4.15 ft	Absorbed Power/BHP:	1.64 hp
%Mtr Safety*:	75%	Efficiency at Design:	49.29 %
Outlet velocity:	18.56 ft/s	Impeller diameter:	8.19 in
PEIcl:	0.49	ERcl:	51
Standby qty:	0	Pump/motor run qty:	2
Load Profile Location:	NA	Building Type:	NA
Climate Zone Type:	NA	Time Period:	8760 (1 Year)

*Motor safety factor above duty point.

Materials of construction

Construction:	Bronze Fitted	Impeller:	Bronze
Rating:	ANSI-125	Pump shaft:	Carbon Steel
Connections:	Inlet: 1.5 in, Outlet: 1 in	Shaft sleeve:ea	304 SS
Casing (volute):	Cast Iron, E-coated	Flexible coupling:	Duraflex coupling
Bearings:	Anti-Friction Grease Lubricated	Casing gasket:	Confined Non-Asbestos Fiber
Drip pan:	No		

Mechanical seal data

Seal type:	Inside Single Spring	Rotating face:	Resin Bonded Carbon
Manufacturer code:	C-ssc L EPSS 2A	Stationary seat:	Sintered Silicon Carbide
Springs:	Stainless Steel	Secondary seal:	EPDM
Rotating hardware:	Stainless Steel	Maximum total dissolved solids (TDS)*:	2000 PPM

*Note: Please ensure proper seal is selected by inputting Total Dissolved Solids (TDS) in PPM in ADEPT if water quality is poor at site. Also select Flush Line Filter or Cyclone Separator if there are other contaminants in the fluid.

Electrical data

Supplier:	Factory Choice	Insulation class:	Class F Insulation
Frame size:	182TC	Motor type:	Inverter Duty
Speed:	1682 rpm	Size:	3 hp
Enclosure:	ODP	Efficiency:	NEMA Premium 12.12
Power supply:	460/3/60		

Operating limits (temperature - pressure)

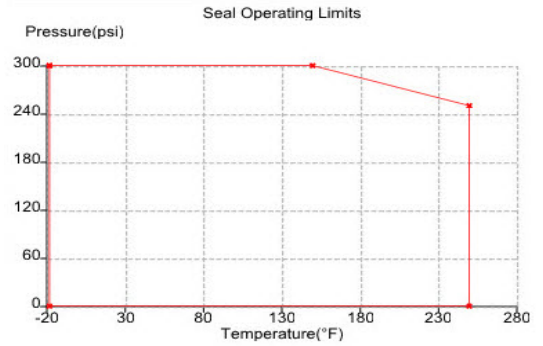
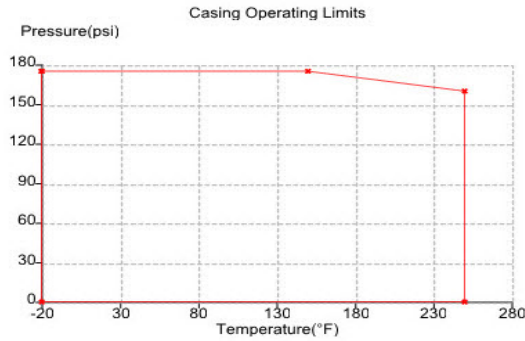

Maximum pressure: 175 psi

Maximum temperature: 250 F

All Pump casings are hydrostatically tested to requirements of ANSI/HI 14.6 standard.

Performance curve

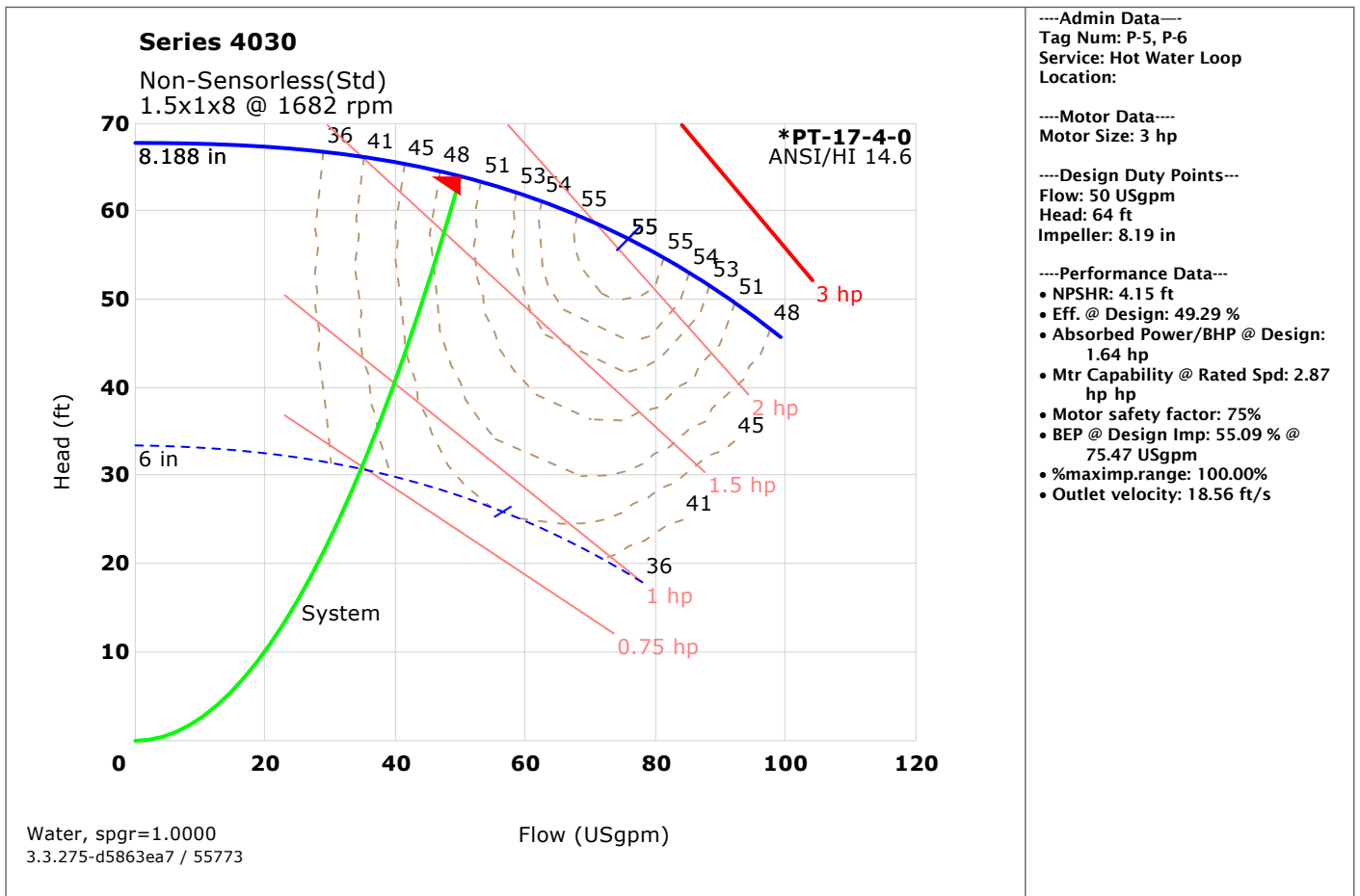

Series 4030

Non-Sensorless(Std)
1.5x1x8 @ 1682 rpm

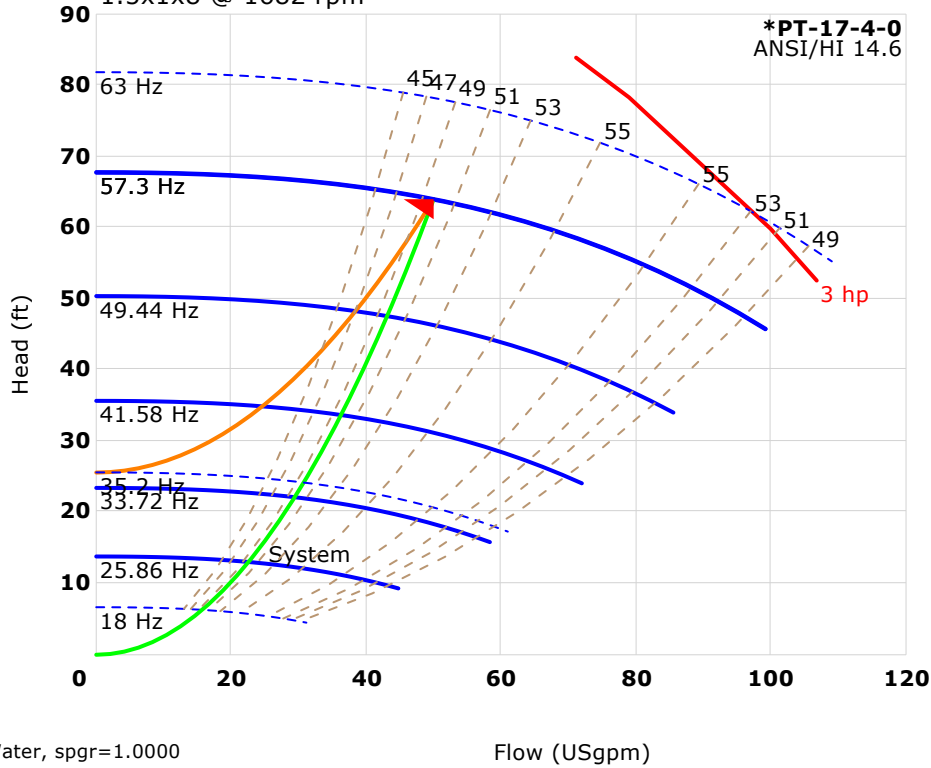

--Control Data--

1. Hmax @ 57.34 Hz:
NPSHR: 4.15 ft
Intersection Pt: 50 USgpm @ 64 ft
bhp=1.64 hp, eff=49.29 %%,
%bepq=66 %%
2. Control (QPC) @ 52.92 Hz:
NPSHR: 3.44 ft
Intersection Pt: 43.75 USgpm @ 55 ft
bhp=1.27 hp, eff=48.03%,
%bepq=62.78%
3. Control (QPC) @ 48.5 Hz:
NPSHR: 2.78 ft
Intersection Pt: 37 USgpm @ 46.63 ft
bhp=0.95 hp, eff=46.09%,
%bepq=57.91%
4. Control (QPC) @ 44.08 Hz:
NPSHR: 2.17 ft
Intersection Pt: 29.5 USgpm @ 38.97 ft
bhp=0.68 hp, eff=42.81%,
%bepq=50.81%
5. Control (QPC) @ 39.66 Hz:
NPSHR: 1.63 ft
Intersection Pt: 20.5 USgpm @ 32.06 ft
bhp=0.46 hp, eff=36.19%,
%bepq=39.15%
6. Hmin: 25.6 ft 35.23 Hz:
NPSHR: 1.15 ft
Intersection Pt: 0 USgpm @ 25.6 ft
(Head Q Min) Setting= 40% Hmax

----Admin Data--

Tag Num: P-5, P-6
Service: Hot Water Loop
Location:

----Motor Data----

Motor Size: 3 hp

----System Design Data---

Piping: Parallel
Run Qty: 2
Fluid: Non-Potable Fluid
Sp.Gr: 1.0000 ,Vis= 31 SSU
Suction: 0 ft
Total Design Flow= 100 USgpm
Total Design Head= 64 ft

---Performance Data---

Total System Flow = 100 USgpm

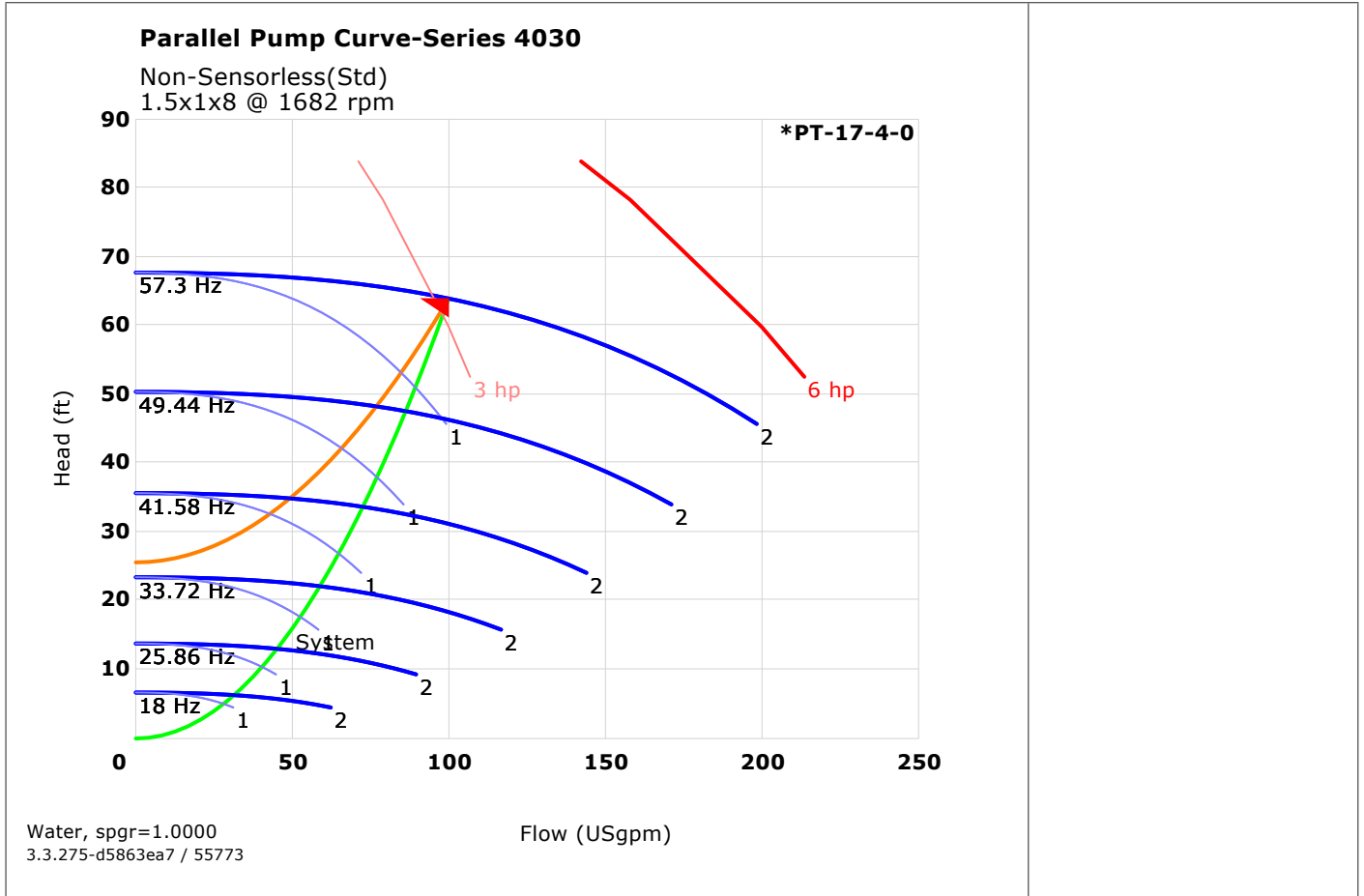

Dimensional data (not for construction)

Side view

Top view

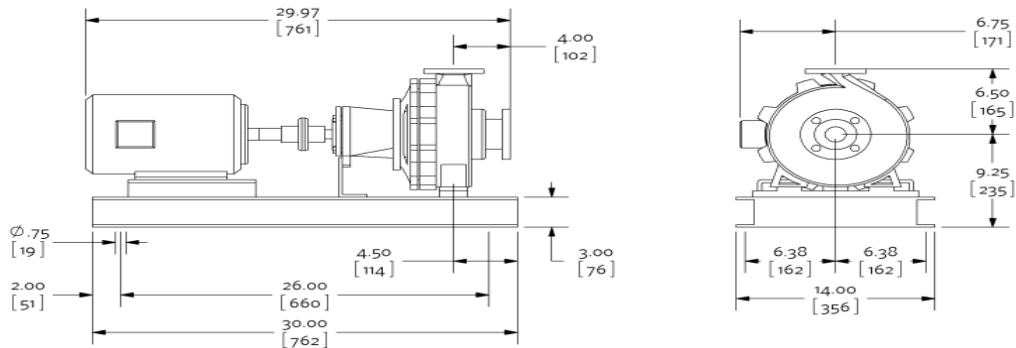

Inverter motor type: Inverter duty

Weight: 213 lb [96.62 kg], Units of measure: inches [millimeters]

- Not to scale
- Tolerance of ± 0.125 inch (± 3 mm) should be used
- For certified dimensions, please contact your Armstrong representative
- Pump equipped with casing drain plug and $\frac{1}{4}$ inch NPT suction and discharge gauge ports

Connection details

Connection	Size	Rating	OD	Bolt quantity*	BCD	Bolt size
------------	------	--------	----	----------------	-----	-----------

Inlet	1.5	ANSI-125	5.00	4	3.88	0.5
Outlet	1	ANSI-125	4.25	4	3.13	0.5

*Equally spaced straddling centreline

Special instructions

Reference Motor Specification AES 05007.

The program has defaulted to a NEMA Premium Efficiency motor supplied with NEMA MG-1 Part 31.4.4.2 insulation standards for inverter-fed polyphase motors.

Selected options

Testing: No Test Certification Required

Seal Environment Accessories: None

VFD Disconnect: Integrated Fused Disconnect

Couplings: Duraflex coupling

Space Heater: No

Motor Thermistor: No Thermistors

Wye-Delta Starting: No

Drip Pan: No

Bearing Current Handling: AEGIS Shaft Ground

Submittal

Ref. #: SQJPE006360_1

Suction guide

Model: SG-2515

Project name:	Representative:	Sam Braddock
Location:	Phone number:	
Date submitted: 1/16/2025 9:34 PM	e-mail:	sbraddock@insightusa.com
Engineer:	Submitted by:	Braddock, Sam

Application design data

Tag	Qty	Model	Pipe Conn.size	Pump Conn.size	Design flowrate	Pressure Drop*	Associated pump
P-5, P-6	2	SG-2515	2.5 in	1.5 in	50 USgpm	0.19 ft	4030 - 1.5x1x8 - 4p - 3 hp - (Factory Choice Motor)

*at design flow

Materials of construction

SG-2515

Body:	Cast Iron	Cover gasket:	Synthetic fiber
Guide vanes:	Cast Iron	Strainer:	Stainless Steel, 0.188"(5mm)Perf..
Cover plate:	Cast Iron	Start-up strainer*:	Fine Mesh Galvanized Steel

*Remove start up strainer after 24 hours of pump operation

Operating limits (temperature - pressure)

SG-2515-Suction Guide-ANSI-125

PRESSURE TEMPERATURE LIMITS

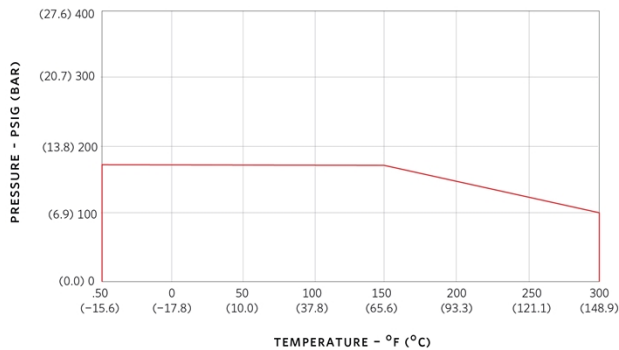

Maximum pressure: 175 psi
Maximum temperature: 300 F

Units are hydrostatically tested to 150% of maximum working pressure

Dimensional data (not for construction)

SG-2515	Weight: 26.31 lb [11.93 kg]
Side view	Top view

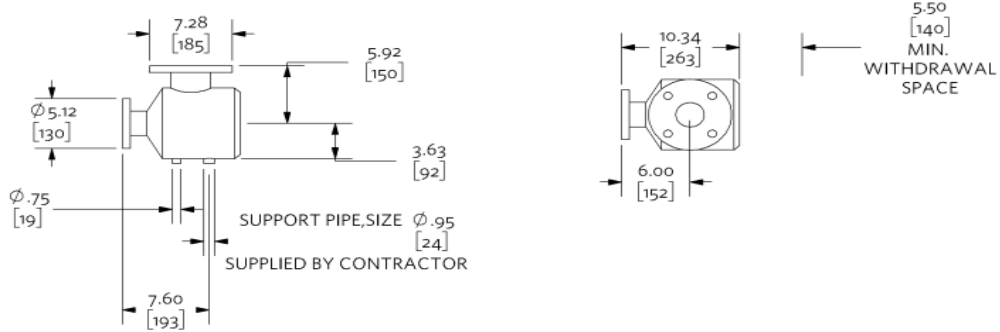

Not to scale
 Units of measure: inches [millimeters]
 Tolerance of +/- 0.125 inch (+/- 3 mm) should be used
 For certified dimensions, please contact your Armstrong representative

Submittal

Ref. #: SQJPE006360_1

Flo-trex valve

Model: FTV-2TS-Flo-Trex Valve-Straight

Project name:	Representative: Sam Braddock
Location:	Phone number:
Date submitted: 1/16/2025 9:34 PM	e-mail: sbraddock@insightusa.com
Engineer:	Submitted by: Braddock, Sam

Application design data

Tag	Qty	Model	Size Inlet/Outlet	Config	Pipe Type	Design flowrate	Pressure Drop*	Associated pump
P-5, P-6	2	FTV-2TS	2 in	Straight	NPT	50 USgpm	3.5 ft	4030 - 1.5x1x8 - 4p - 3 hp - (Factory Choice Motor)

*at design flow

Materials of construction

FTV-2TS-Flo-Trex Valve-Straight

Body:	304 Stainless Steel	Spring:	304 Stainless Steel
Disc:	Brass	O rings:	EPDM
Seat:	Not Applicable	2 metering ports:	Brass Body with EPDM Check and Gasketed Cap
Stem:	Brass	2 drain tappings:	1/4in NPT with SS 304 Plug

Operating limits (temperature - pressure)

FTV-2TS-Flo-Trex Valve-Straight

PRESSURE TEMPERATURE LIMITS

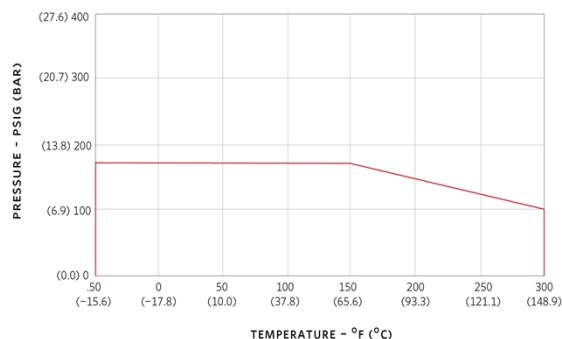

Maximum pressure: 175 psi
Maximum temperature: 300 F

Dimensional data (not for construction)

Model: FTV-2TS-Flo-Trex Valve-Straight

Weight: 6 lb [2.72 kg]

Side view

Front view

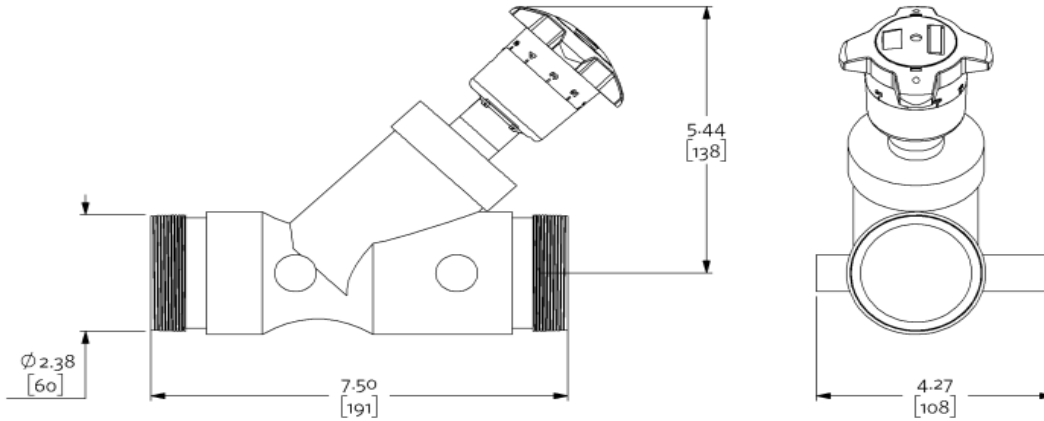

Not to scale

Units of measure: inches [millimeters]

Tolerance of +/- 0.125 inch (+/- 3 mm) should be used

For certified dimensions, please contact your Armstrong representative

Submittal

Ref. #: SQJPE006360_1

Series H ECM in-line circulator

Model: Series H ECM-H54 ECM-0.75 hp

Project name:	Representative: Sam Braddock
Location:	Phone number:
Date submitted: 1/16/2025 9:34 PM	e-mail: sbraddock@insightusa.com
Engineer:	Submitted by: Braddock, Sam

Application design data

Tag number: P-7	Pipe orientation: Single
Service: Boiler #1	Suction pressure: 0 ft
Location:	Fluid: Non-Potable Fluid - Water
Quantity: 1	Operating temperature: 60 °F
Duty flow per pump: 50 USgpm	Viscosity: 31 SSU
Duty head: 25 ft	Specific gravity: 1.00
Total dissolved solids: 0 ppm	Impeller diameter: 5.25 in
NPSHR: 1 ft	Efficiency at Design: N/A
PEIvl: Not applicable	ERvl: Not applicable
Outlet velocity: N/A	Absorbed Power/BHP: N/A

Materials of construction

Construction: Bronze Fitted	Impeller: Non-Ferrous
Rating: ANSI-125	Bearings: Ball Bearing-Maintenance Free
Connections: Inlet:2 in, Outlet:2 in	

Mechanical seal data

Seal type: Inside Single Spring	Rotating face: Carbon
Manufacturer code: Armseal, Circs	Stationary seat: Silicon Carbide
Springs: Stainless Steel	Secondary seal: BUNA-N
Rotating hardware: Brass	Maximum total dissolved solids (TDS)*: 2000 PPM

*Note: Please ensure proper seal is selected by inputting Total Dissolved Solids (TDS) in PPM in ADEPT if water quality is poor at site. Also select Flush Line Filter or Cyclone Separator if there are other contaminants in the fluid.

Motor electrical data

Supplier: Factory Choice	Insulation class: Class F Insulation
Size: 0.75 hp	Inverter motor type: [none]
Frame size: Not applicable	Efficiency: ECM
Enclosure: ODP	Speed: 1750 rpm
Motor power supply: 115/1/60	

A/E to confirm this is acceptable

**OPTIMA:
ACCEPTABLE**

Operating limits (temperature - pressure)

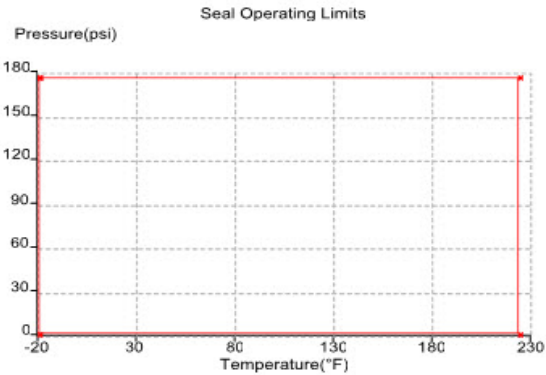
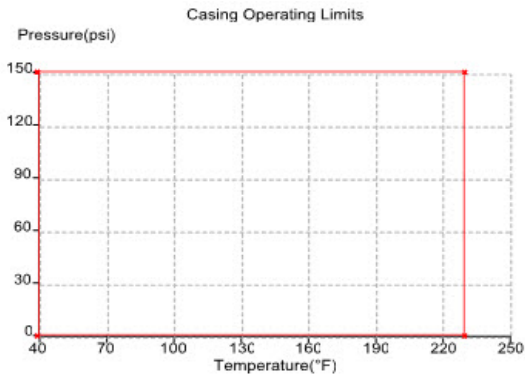

Maximum pressure: 175 psi
Maximum temperature: 225 °F

All Pump casings are hydrostatically tested to requirements of ANSI/HI 14.6 standard.

Performance curve

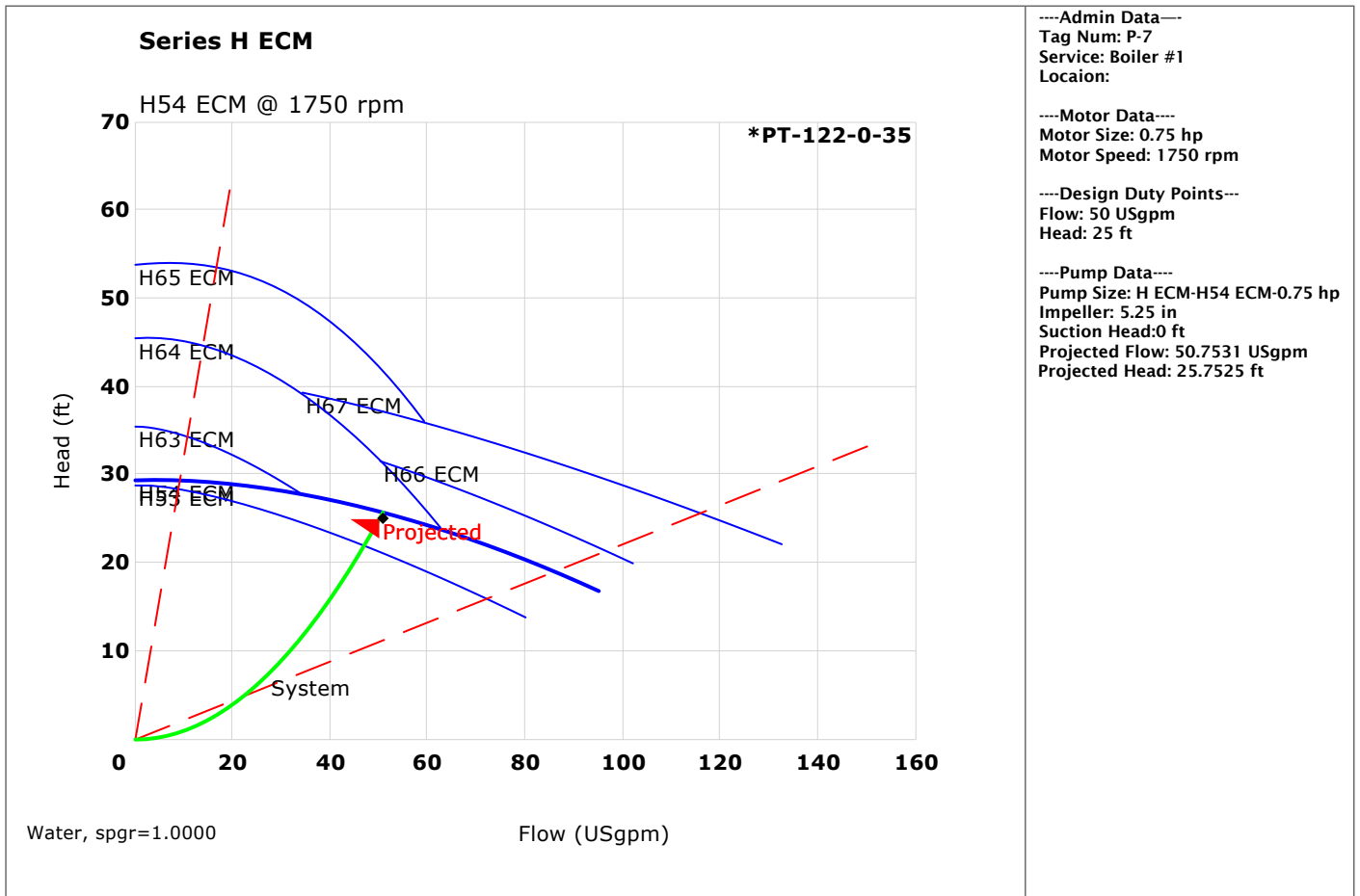

Dimensional data (not for construction)

Side view

Top view

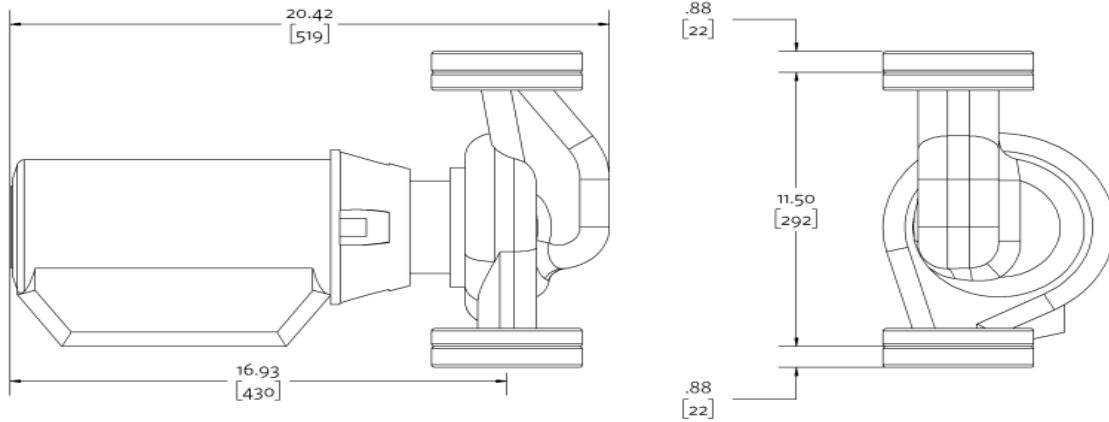

Weight: 66 lb [29.94 kg], Units of measure: inches [millimeters]

- Not to scale
- Tolerance of ± 0.125 inch (± 3 mm) should be used
- For certified dimensions, please contact your Armstrong representative

Connection details

Connection	Size	Rating	OD	Bolt quantity*	BCD	Bolt size
Inlet	2	ANSI-125	6.00	4	4.75	0.625
Outlet	2	ANSI-125	6.00	4	4.75	0.625

*Equally spaced straddling centreline

Submittal

Ref. #: SQJPE006360_1

Series H ECM in-line circulator

Model: Series H ECM-H54 ECM-0.75 hp

Project name:	Representative: Sam Braddock
Location:	Phone number:
Date submitted: 1/16/2025 9:34 PM	e-mail: sbraddock@insightusa.com
Engineer:	Submitted by: Braddock, Sam

Application design data

Tag number: P-8	Pipe orientation: Single
Service: Boiler #2	Suction pressure: 0 ft
Location:	Fluid: Non-Potable Fluid - Water
Quantity: 1	Operating temperature: 60 °F
Duty flow per pump: 50 USgpm	Viscosity: 31 SSU
Duty head: 25 ft	Specific gravity: 1.00
Total dissolved solids: 0 ppm	Impeller diameter: 5.25 in
NPSHR: 1 ft	Efficiency at Design: N/A
PEIvl: Not applicable	ERvl: Not applicable
Outlet velocity: N/A	Absorbed Power/BHP: N/A

Materials of construction

Construction: Bronze Fitted	Impeller: Non-Ferrous
Rating: ANSI-125	Bearings: Ball Bearing-Maintenance Free
Connections: Inlet:2 in, Outlet:2 in	

Mechanical seal data

Seal type: Inside Single Spring	Rotating face: Carbon
Manufacturer code: Armseal, Circs	Stationary seat: Silicon Carbide
Springs: Stainless Steel	Secondary seal: BUNA-N
Rotating hardware: Brass	Maximum total dissolved solids (TDS)*: 2000 PPM

*Note: Please ensure proper seal is selected by inputting Total Dissolved Solids (TDS) in PPM in ADEPT if water quality is poor at site. Also select Flush Line Filter or Cyclone Separator if there are other contaminants in the fluid.

Motor electrical data

Supplier: Factory Choice	Insulation class: Class F Insulation
Size: 0.75 hp	Inverter motor type: [none]
Frame size: Not applicable	Efficiency: ECM
Enclosure: ODP	Speed: 1750 rpm
Motor power supply: 115/1/60	

A/E confirm this is acceptable.

**OPTIMA:
ACCEPTABLE**

Operating limits (temperature - pressure)

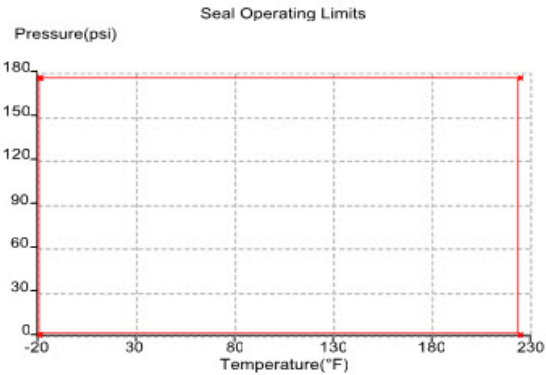
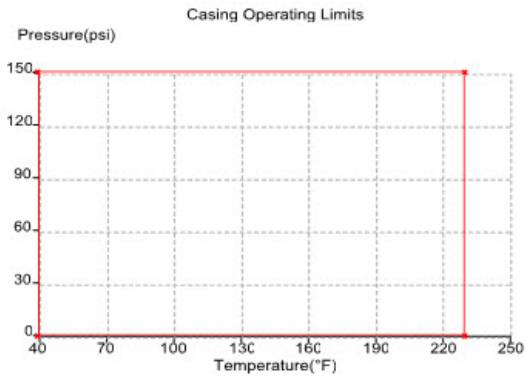

Maximum pressure: 175 psi
Maximum temperature: 225 °F

All Pump casings are hydrostatically tested to requirements of ANSI/HI 14.6 standard.

Performance curve

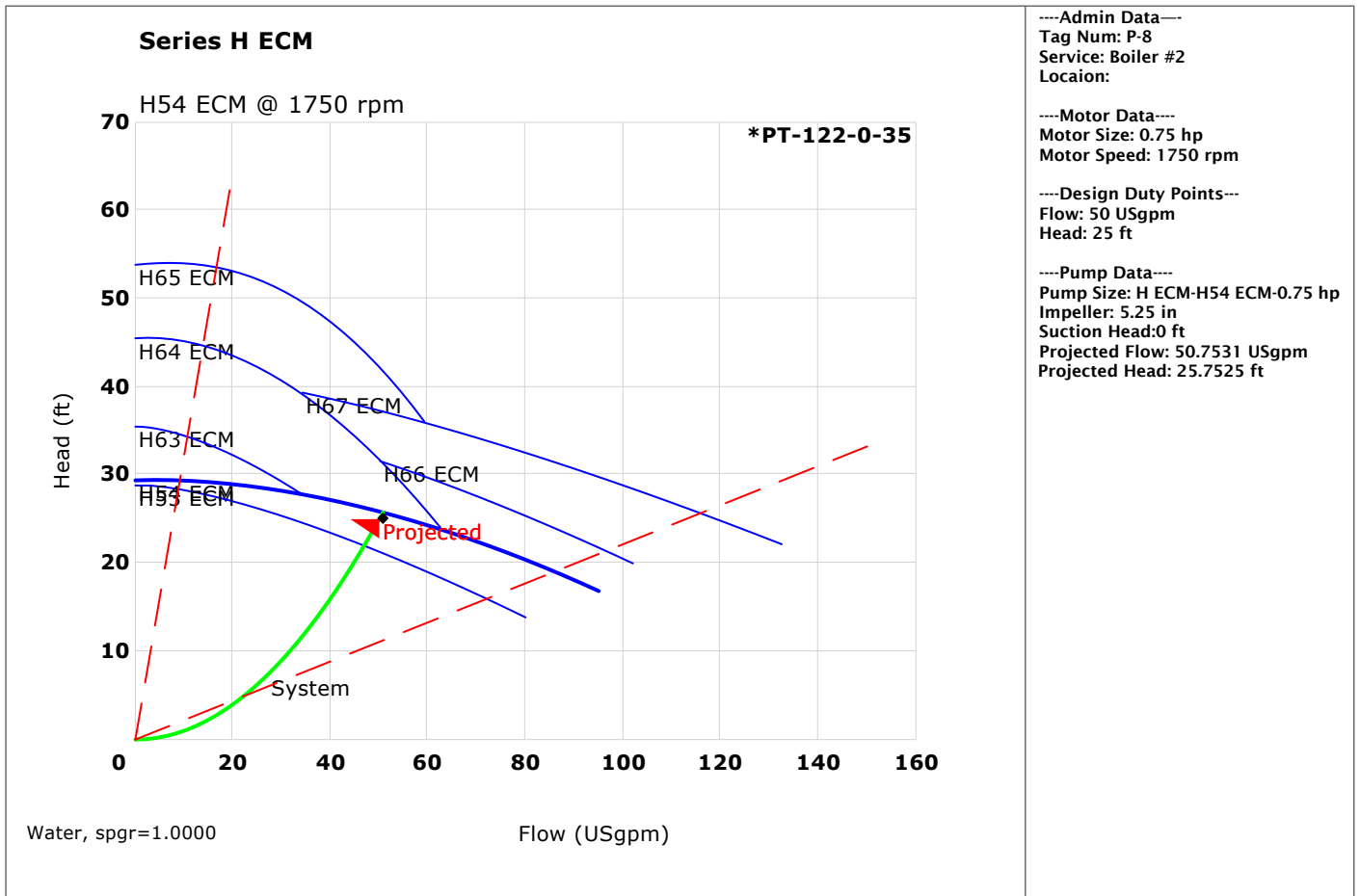

Dimensional data (not for construction)

Side view

Top view

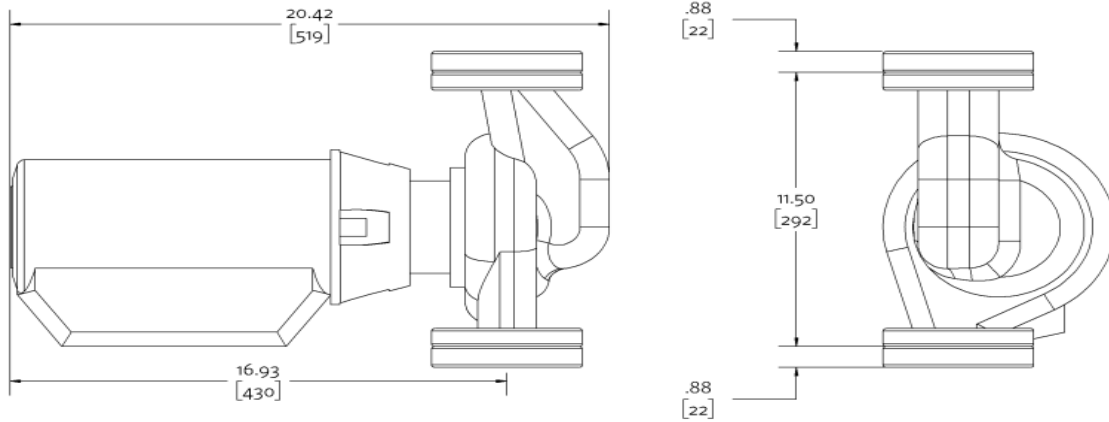

Weight: 66 lb [29.94 kg], Units of measure: inches [millimeters]

- Not to scale
- Tolerance of ± 0.125 inch (± 3 mm) should be used
- For certified dimensions, please contact your Armstrong representative

Connection details

Connection	Size	Rating	OD	Bolt quantity*	BCD	Bolt size
Inlet	2	ANSI-125	6.00	4	4.75	0.625
Outlet	2	ANSI-125	6.00	4	4.75	0.625

*Equally spaced straddling centreline

VORTEX AIR SEPARATORS | MODELS VA/VAS |
4" to 12" | SUBMITTAL

File No: 37.621
Date: SEPTEMBER 22, 2016
Supersedes: 37.621
Date: AUGUST 03, 2016

Job: _____ Representative: _____

_____ Order no.: _____ Date: _____

Engineer: _____ Submitted by: _____ Date: _____

Contractor: _____ Approved by: _____ Date: _____

DATA

Model no. ordered: _____ Qty: _____

Tag no.: _____

MATERIALS OF CONSTRUCTION

Shell: 4" to 6" Models: Cast Iron

8" to 12" Models: Fabricated Steel

Strainer: Stainless Steel mesh (¼" x ¾")

Gasket: Non-asbestos

TECHNICAL DATA

Max. working temperature: 375°F (190°C)

Max. working pressure: 4" to 6" Models: 160 PSI (1103 kPa)
8" to 12" Models: 165 PSI (1140 kPa)

Connection type: 4" to 6" Models: 150# flanged ANSI flat face
8" to 12" Models: 150# flanged ANSI raised face

TYPICAL SPECIFICATION

Furnish & install an Armstrong Vortex® Air separator, Model _____ VA or model _____ VAS (with strainer) with flanged tangential connections as shown on plans. The unit shall be designed and built in accordance with the latest revisions of ASME Pressure vessel code, section VIII, Division 1. A blowdown connection is provided for routine cleaning of the unit.

NOTES

All models designed and built to ASME Pressure vessel code, section VIII, Division 1.

MODEL		DIMENSIONS inches (mm)										MAX. FLOW RATE IN USgpm (L/s) FOR LINE VELOCITY ft/s (m/s)			WEIGHT lbs. (kg)		STRAINER SCREEN FREE AREA
LESS STRAINER	WITH STRAINER	A	B	C	D	E	F	H	J	K	N	4 (1.22)	6 (1.83)	8 (2.44)	VA	VAS	Sq. in. (Sq. cm)
VA-4	VAS-4	4.00 (102)	1.50 (38)	9.50 (241)	18.00 (457)	2.25 (57)	6.80 (173)	22.25 (565)	10.75 (273)	16.00 (406)	9.00 (229)	160 (10.1)	240 (15.1)	320 (20.2)	121 (55)	151 (69)	76 (490)
VA-5	VAS-5	5.00 (127)	1.50 (38)	11.00 (279)	20.00 (508)	2.88 (73)	8.69 (221)	28.00 (711)	12.75 (324)	19.00 (483)	10.00 (254)	250 (9.84)	375 (14.8)	500 (31.6)	173 (79)	207 (94)	124 (800)
VA-6	VAS-6	6.00 (152)	1.50 (38)	12.50 (318)	24.00 (610)	4.00 (102)	9.85 (250)	32.24 (819)	16.00 (406)	22.00 (558)	12.00 (305)	360 (22.7)	540 (34.1)	720 (45.4)	264 (120)	306 (139)	183 (1181)
VA-8	VAS-8	8.00 (203)	2.00 (51)	16.00 (406)	28.00 (711)	5.00 (127)	12.81 (310)	41.25 (1048)	20.00 (508)	26.00 (660)	14.00 (356)	630 (39.8)	940 (59.3)	1250 (78.9)	228 (103)	332 (151)	302 (1949)
VA-10	VAS-10	10.00 (254)	2.00 (51)	20.00 (508)	32.00 (813)	5.75 (146)	15.00 (381)	49.50 (1257)	24.00 (610)	29.00 (737)	16.00 (406)	990 (62.5)	1500 (94.6)	1980 (124.9)	390 (177)	547 (248)	452 (2916)
VA-12	VAS-12	12.00 (305)	2.00 (51)	26.00 (660)	38.00 (965)	7.75 (197)	17.56 (446)	61.25 (1556)	30.00 (762)	36.00 (914)	19.00 (483)	1400 (88.3)	2100 (132.5)	2800 (176.7)	609 (276)	856 (388)	679 (4381)

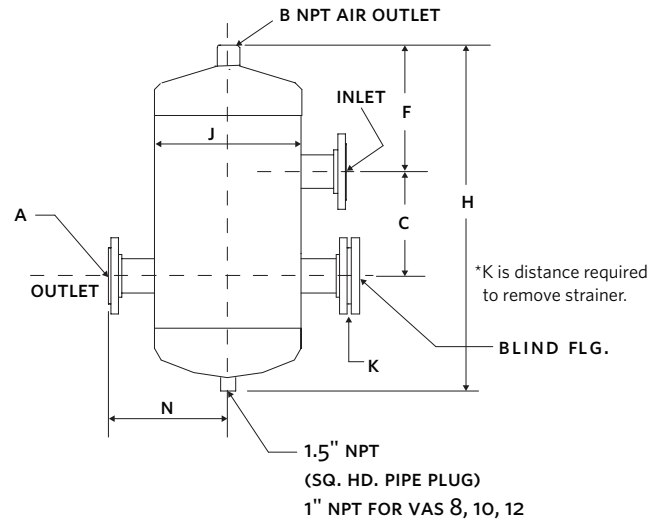
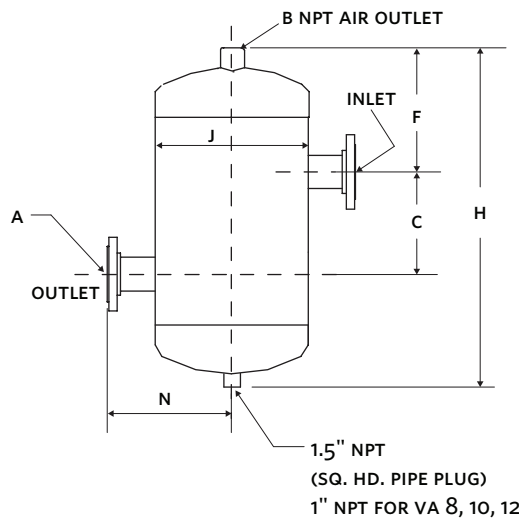
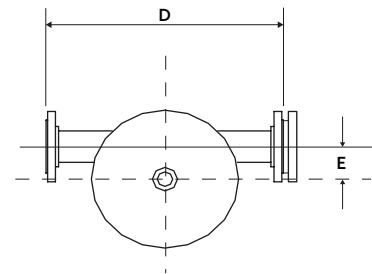
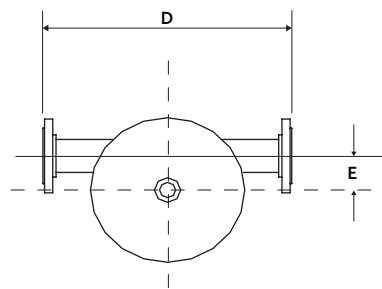

TORONTO
+1 416 755 2291

BUFFALO
+1 716 693 8813

BIRMINGHAM
+44 (0) 8444 145 145

MANCHESTER
+44 (0) 8444 145 145

BANGALORE
+91 (0) 80 4906 3555

SHANGHAI
+86 21 3756 6696

SÃO PAULO
+55 11 4781 5500

MODEL VA

MODEL VAS

Vortex Air Separators - Models VA / VAS: 2" to 3"

SUBMITTAL

JOB: _____	REPRESENTATIVE: _____
ENGINEER: _____	ORDER NO: _____ DATE: _____
CONTRACTOR: _____	SUBMITTED BY: _____ DATE: _____
	APPROVED BY: _____ DATE: _____

MODEL NO. ORDERED: _____ QTY.: _____
 TAG NO.: _____
 ASME CONSTRUCTION: YES NO

TECHNICAL DATA

Max. Working Temperature	350°F (176°C)
Max. Working Pressure	160 psi (1105 kPa)
Connection Type	Threaded NPT

MATERIALS OF CONSTRUCTION

Shell	Cast Iron
Strainer	Stainless Steel Mesh (1/4" x 3/4")
Gasket	Non-Asbestos

TYPICAL SPECIFICATION

ASME Coded Units

Furnish & install an Armstrong Vortex® Air Separator, Model ____ VA or Model ____ VAS (with strainer) with NPT tangential connections as shown on plans. The unit shall be designed and built in accordance with the latest revisions of ASME Pressure Vessel Code, Section VIII, Division 1. A blowdown connection is provided for routine cleaning of the unit.

Non-ASME Coded Units

Furnish & install an Armstrong Vortex^a Air Separator, Model ____ VA or Model ____ VAS (with strainer) with NPT tangential connections as shown on plans. The unit is considered as "part of the piping" and no Code Inspection applies. A blowdown connection is provided for routine cleaning of the unit.

MODEL		DIMENSIONS inches (mm)									FLOW RATE in USgpm (L/s) for LINE VELOCITY ft/s (m/s)			WEIGHT lbs. (kg)		STRAINER SCREEN FREE AREA
LESS STRAINER	WITH STRAINER	A	B	C	D	F	H	J	K	N	4 (1.22)	6 (1.83)	8 (2.44)	VA	VAS	Sq. in. (Sq. cm)
VA-2	VAS-2	2.00 (51)	0.75 (19)	7.50 (191)	12.75 (324)	4.75 (121)	15.75 (400)	8.63 (219)	7.00 (178)	7.75 (197)	42 (2.6)	63 (4.0)	84 (5.3)	70 (32)	70 (32)	40 (258)
VA-2-1/2	VAS-2-1/2	2.50 (64)	0.75 (19)	9.25 (235)	15.50 (394)	6.15 (156)	19.00 (483)	10.70 (272)	7.88 (200)	9.50 (241)	60 (3.8)	90 (5.7)	120 (7.6)	100 (45)	100 (45)	67 (432)
VA-3	VAS-3	3.00 (76)	0.75 (19)	9.25 (235)	15.50 (394)	6.15 (156)	19.00 (483)	10.70 (272)	7.88 (200)	9.50 (241)	93 (5.9)	140 (8.8)	185 (11.7)	100 (45)	100 (45)	67 (432)

Note: Dimension "K" applies to only VAS Models.

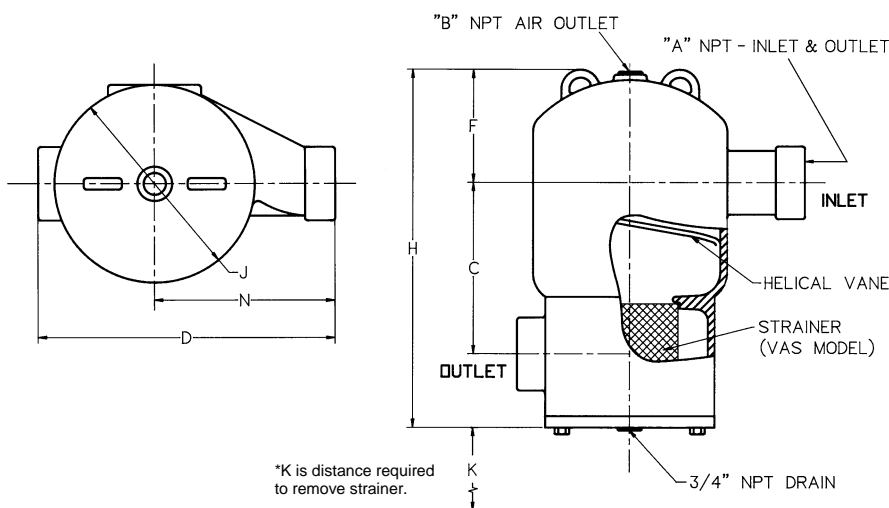

Armstrong Pumps Inc.
 93 East Avenue
 North Tonawanda, New York
 U.S.A. 14120-6594
 Tel: (716) 693-8813
 Fax: (716) 693-8970
 www.armstrongpumps.com

S.A. Armstrong Limited
 23 Bertrand Avenue
 Toronto, Ontario
 Canada, M1L 2P3
 Tel: (416) 755-2291
 Fax: (416) 759-9101



© S.A. Armstrong Limited 2003

Armstrong Pumps Limited
 Peartree Road, Stanway
 Colchester, Essex
 United Kingdom, CO3 0LP
 Tel: +44 (0) 1206 579491
 Fax: +44 (0) 1206 760532

Armstrong Darling
 9001 De L'Innovation, Suite 200
 Montreal, Quebec
 Canada, H1J 2X9
 Tel: (514) 352-2424
 Fax: (514) 352-2425



L SERIES | PRE-CHARGED (ASME) EXPANSION TANK |
SUBMITTAL

File No: 37.52
Date: APRIL 21, 2016
Supersedes: 37.52
Date: NOVEMBER 24, 2016

Job: _____ Representative: _____

Order no.: _____ Date: _____
Engineer: _____ Submitted by: _____ Date: _____
Contractor: _____ Approved by: _____ Date: _____

DATA

Model no. ordered: _____ Qty: _____
Tag no.: _____ Charge pressure: _____ psi/kPa

Optional California sight-glass and seismic clips: Yes No

Standard factory charge is 12 psi (83 kPa) unless otherwise specified.

NOTES

- Not for Domestic Potable Water Systems.
- Designed and constructed per ASME, Section VIII, Division 1.
- California code sight-glass and seismic clips available as an option.
- Allow a minimum of 18" (457 mm) clearance for system piping.

MATERIALS OF CONSTRUCTION

Shell: Carbon steel
Bladder: Heavy Duty Butyl

OPERATING CONDITIONS

Temperature Range: 40°F - 240°F (4.4°C - 115.5°C)
Maximum Pressure: 125 psi (862 kPa)

TYPICAL SPECIFICATION

Furnish and install, as shown on the plans, Armstrong Model _____-L ASME pre-charged bladder Expansion Tank, stamped for 125 psi (862 kPa) working pressure. Each tank will be supplied with a heavy duty butyl replaceable bladder. Tank shall be supplied with a ring base, lifting rings, and NPT system connection. An air charging valve connection (standard tire valve) shall be provided to facilitate adjusting pre-charge pressure to meet actual system conditions.

MODEL	TANK VOLUME	MAXIMUM ACCEPTANCE VOLUME	A	B	D	SYSTEM CONNECTION NPT	DRAIN PLUG	SHIPPING WEIGHT
	gal.(L)		inches (mm)			inches (mm)		lbs.(kg)
A200-L	53 (200)	53 (200)	24.00 (610)	38.40 (1475)	19.00 (483)	1.50 (38)	0.75 (19)	225 (102.1)
A300-L	80 (300)	80 (300)	24.00 (610)	52.27 (1328)	19.00 (483)	1.50 (38)	0.75 (19)	285 (129.3)
A400-L	106 (400)	106 (400)	24.00 (610)	66.14 (1680)	19.00 (483)	1.50 (38)	0.75 (19)	350 (158.8)
A500-L	132 (500)	132 (500)	24.00 (610)	80.14 (2036)	19.00 (483)	1.50 (38)	0.75 (19)	410 (186.0)
A600-L	158 (600)	158 (600)	30.00 (762)	64.75 (1645)	24.00 (610)	1.50 (38)	0.75 (19)	430 (195.0)
A800-L	211 (800)	211 (800)	30.00 (762)	82.44 (2094)	24.00 (610)	1.50 (38)	0.75 (19)	525 (238.1)
A1000-L	264 (1000)	264 (1000)	36.00 (914)	73.90 (1877)	28.00 (711)	1.50 (38)	0.75 (19)	565 (256.3)
A1200-L	317 (1200)	317 (1200)	36.00 (914)	86.00 (2184)	28.00 (711)	1.50 (38)	0.75 (19)	680 (308.4)
A1400-L	370 (1400)	370 (1400)	36.00 (914)	98.50 (2502)	28.00 (711)	1.50 (38)	0.75 (19)	750 (340.2)
1600-L	422 (1600)	422 (1600)	48.00 (1219)	74.00 (1880)	42.00 (1067)	1.50 (38)	0.75 (19)	1100 (498.9)
2000-L	528 (2000)	528 (2000)	48.00 (1219)	87.00 (2210)	42.00 (1067)	1.50 (38)	0.75 (19)	1280 (580.6)
2500-L	660 (2495)	660 (2495)	48.00 (1219)	102.00 (2591)	42.00 (1067)	2.00 (51)	0.75 (19)	1435 (652)
3000-L	792 (2994)	792 (2994)	48.00 (1219)	122.00 (3099)	42.00 (1067)	2.00 (51)	0.75 (19)	1550 (705)
4000-L	1056 (3992)	1056 (3992)	60.00 (1524)	102.00 (2591)	54.00 (1372)	2.00 (51)	0.75 (19)	2638 (1199)
5000-L	1320 (4997)	1320 (4997)	60.00 (1524)	125.00 (3175)	54.00 (1372)	2.00 (51)	0.75 (19)	3246 (1472)

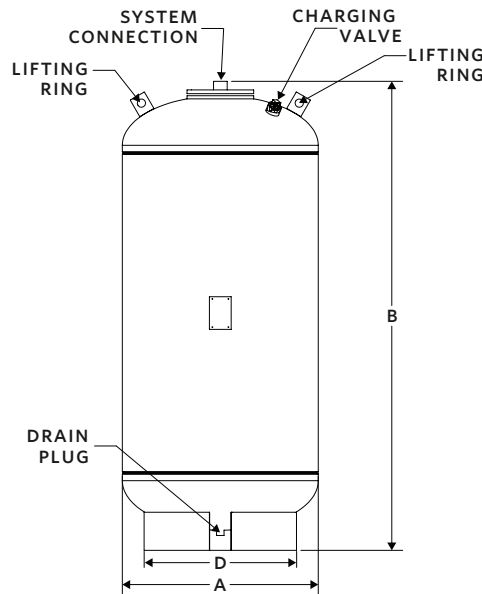

MODELS A200-L TO A1400-L

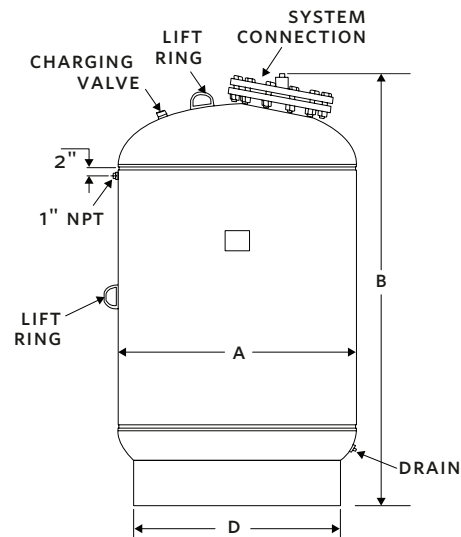

MODELS 1600-L TO 5000-L

TORONTO
+1 416 755 2291

BUFFALO
+1 716 693 8813

BIRMINGHAM
+44 (0) 8444 145 145

MANCHESTER
+44 (0) 8444 145 145

BANGALORE
+91 (0) 80 4906 3555

SHANGHAI
+86 21 3756 6696

SÃO PAULO
+55 11 4781 5500

BFT Series Chemical By-Pass Feeder Tank

The Wheatley Chemical By-Pass Feeder Tank is design for water treatment in closed circulating water systems and boilers. Great for use with chilled water treatment such as cooling systems and hot water treatment in heating systems. Helps prolong the life of heating and cooling systems.

Features:

- Carbon Steel Construction
- Self Supported Bottom
- Coarse Thread with 2 1/2 turn design
- Cast iron body and cover
- Working pressure rated at 300 PSI
- Caps are Easy Quick Opening
- Bottom of cap is epoxy coated for liquid

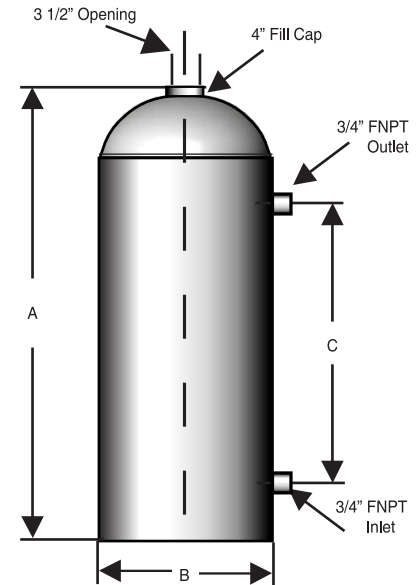

TWO FITTINGS STYLE

PART NUMBER	VOLUME GALLONS	HEIGHT A (IN.)	DIAMETER B (IN.)	C (IN.)	WEIGHT (LBS)
BFT-002-O	2	21 1/4	6	12 3/4	23
BFT-005-O	5	19 3/4	10	10 1/2	37
BFT-010-O	10	35 3/4	10	26 1/2	60
BFT-012-O	12	42	10	32 3/4	68

BFT Optional Parts

Support/Filter Bag sold separately



FBK-002 Support
 FBK-005 Support
 FBK-6 PACK Replacement Bags

All packaging materials, thread protectors, plastic plugs and caps must be removed before installation.

Dimensions are subject to change without notice, please confirm actual dimensions with factory at time of order.

JOB NAME _____
 LOCATION _____

 CONTRACTOR _____
 CONTRACTOR P.O. NO. _____

ITEMS	QUANTITY
_____	_____
_____	_____
_____	_____
_____	_____
_____	_____
_____	_____

American WHEATLEY
HVAC PRODUCTS®
A GFP COMPANY

2701 W. Concord Street
 Broken Arrow, OK 74012
 Toll Free: 866-204-5229
 PH: 918-317-0401
 FAX: 918-317-0407
 www.wheatleyhvac.com
 e-mail: sales@globalflowproducts.com

TCHS - FLG

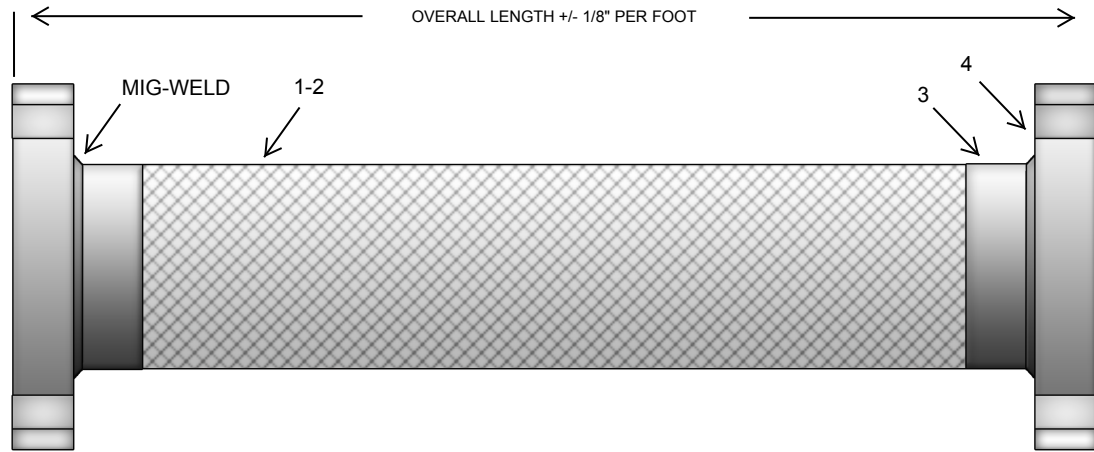

MATERIALS

- #1-2 HOSE: T-321 STAINLESS STEEL CORRUGATED HOSE 1-LAYER T-304 BRAID
- #3 BRAID BAND: T-304 STAINLESS STEEL
- #4 END FITTING: CARBON STEEL PLATE FLANGES 150# DRILL

QTY	MODEL NUMBER	SIZE	OAL	MAX O.D.	WRK. PSIG	MAX TEST	@ TEMP.	LATERAL OFFSET	WT. LBS.
	TCHS-150-FLG	1 1/2"	9"	1.91"	370	555	70° F	1/16"	8
	TCHS-200-FLG	2"	9"	2.46"	370	555	70° F	1/16"	10
	TCHS-250-FLG	2 1/2"	9"	3.45"	400	600	70° F	1/16"	14
	TCHS-300-FLG	3"	9"	4.01"	288	431	70° F	1/16"	15
	TCHS-400-FLG	4"	9"	5.03"	250	375	70° F	1/16"	19
	TCHS-500-FLG	5"	11"	6.10"	200	300	70° F	1/16"	26
	TCHS-600-FLG	6"	11"	7.15"	220	330	70° F	1/16"	29
	TCHS-800-FLG	8"	12"	9.44"	215	323	70° F	1/16"	54
	TCHS-1000-FLG	10"	13"	11.49"	200	350	70° F	1/16"	68
	TCHS-1200-FLG	12"	14"	13.51"	160	240	70° F	1/16"	102
	TCHS-1400-FLG	14"	14"	15.67"	150	225	70° F	1/16"	126
	TCHS-1600-FLG	16"	14"	17.31"	110	165	70° F	1/16"	148

TEMPERATURE DERATING FACTORS: MULTIPLY X WRK. PSIG								
200° F	250° F	300° F	350° F	400° F	500° F	600° F	700° F	
0.94	0.92	0.88	0.86	0.83	0.78	0.74	0.7	

DRAWN BY:

DRAWING NUMBER:

REV:

SIGNATURE:

DATE:

PO NUMBER:

PROJECT:

CUSTOMER:

NOTES: