

HVAC GENERAL NOTES:

- ALL MECHANICAL WORK SHALL CONFORM TO ALL LOCAL, STATE AND BUILDING CODES, ALL GOVERNMENT CODES, NFPA, ASME AND ASHRAE STANDARDS.
- ALL EQUIPMENT LOADING AND METHODS OF SUPPORT SHALL BE REVIEWED BY THE OWNER'S STRUCTURAL ENGINEER. COORDINATE WITH OWNER.
- DUCT PENETRATIONS SHALL CONFORM TO THE FIRE RATINGS OF EACH SPECIFIC PARTITION TYPE. CONTRACTOR SHALL COORDINATE WITH ARCHITECTURAL DRAWINGS.
- CONTRACTOR MUST COORDINATE WITH OWNER TO DETERMINE THE EXTENT OF OVERTIME HOURS.
- CONTRACTOR SHALL PRESSURE TEST ALL PIPING IN ACCORDANCE WITH SPECIFICATIONS. TESTING SHALL BE DONE IN THE PRESENCE OF OWNER.
- CONTRACTOR SHALL INCLUDE PROVISIONS FOR TEMPORARY PIPING AS REQUIRED TO MAINTAIN SERVICE TO OTHER SPACES.
- PROVIDE 1 SET OF AS-BUILTS AND 2 COPIES OF THE CERTIFIED TESTING AND BALANCING REPORT TO THE LANDLORD UPON COMPLETION OF THE PROJECT.
- ALL WORK GENERATING OBJECTIONABLE NOISE SHALL BE COORDINATED WITH LANDLORD.
- HVAC EQUIPMENT SHALL BE ARRANGED TO MINIMIZE VIBRATION AND NOISE PROPAGATION.
- ALL WORK AFFECTING EXISTING BUILDING SYSTEMS SHALL BE COORDINATED WITH THE BUILDING INCLUDING ALL SHUT-DOWNS.
- CONTRACTOR TO COORDINATE ALL WORK WITH BUILDING MANAGEMENT AND BUILDING ENGINEERS. ALL WORK AFFECTING EXISTING SYSTEMS SHALL BE COORDINATED WITH BUILDING MANAGEMENT INCLUDING ALL SHUTDOWNS. COORDINATE ALL WORK WITH THE OTHER TRADES.
- ALL EXISTING EQUIPMENT TO REMAIN SHALL BE CLEANED, REFURBISHED AND TESTED. REPLACE PARTS AS REQUIRED TO OBTAIN OPTIMAL PERFORMANCE. REPORT FINDINGS TO ENGINEER PRIOR TO COMMENCEMENT OF WORK.
- CONTRACTOR SHALL PROVIDE AIR BALANCING UPON COMPLETION OF WORK. CONTRACTOR SHALL PROVIDE BALANCE REPORT TO ENGINEER.
- ALL ATC WIRING SHALL BE PROVIDED IN EMT WITHIN MECHANICAL ROOMS AND UTILITY ROOMS (I.E. ELEVATOR MACHINE ROOMS, ELECTRICAL ROOMS, ETC.). PLENUM RATED CABLING ELSEWHERE. ALL OUTDOOR ATC WIRING SHALL BE PROVIDED WITHIN RIGID METAL CONDUIT.
- ALL ATC PANELS AND HVAC CONTROL PANELS SHALL BE CAPABLE OF BEING INTERLOCKED WITH THE TENANT'S BMS SYSTEM AS REQUIRED TO MONITOR THE SYSTEM(S) AND CONTROL THE SYSTEM(S) PER THE SEQUENCE OF OPERATIONS.
- COORDINATE ALL HVAC EQUIPMENT WITH OTHER TRADES (I.E. PLUMBING, SPRINKLER, ELECTRICAL POWER AND LIGHTING, ARCHITECTURAL, ETC.) PROVIDE COORDINATED SHOP DRAWINGS INDICATING ALL OF THE MANUFACTURER'S RECOMMENDED CLEARANCES UNOBSTRUCTED FOR REVIEW PRIOR TO INSTALLATION.
- CONTRACTOR TO PROVIDE UL LISTED FIRE STOPPING SYSTEM FOR ALL THROUGH PENETRATIONS INCLUDING BUT NOT LIMITED TO DUCTWORK, PIPING, HANGERS, CONDUIT, ETC.
- MANUFACTURERS SYSTEM MUST BE PART OF A UL RATED SYSTEM. LOCATIONS AND TYPES OF FIRESTOPPING SYSTEM INSTALLATIONS SHALL BE COORDINATED WITH ARCHITECTURAL AND LIFE SAFETY PLANS TO DETERMINE SCOPE.
- CONTRACTOR TO PROVIDE ENGINEER WITH ASSOCIATED MANUFACTURER'S UL DETAIL OF ALL APPLICABLE PENETRATIONS FOR APPROVAL.
- FIRE STOPPING SYSTEMS MANUFACTURERS SHALL BE HILTI, 3M, STI, OR APPROVED EQUAL.
- CONTRACTOR TO COORDINATE FIRE STOPPING INSTALLATION WITH PROJECT SPECIAL INSPECTOR PRIOR TO INSTALLATION. FIRESTOPPING INSTALLATION INSPECTION SHALL BE PROVIDED BY SPECIAL INSPECTOR. ALL APPLICABLE FIRESTOPPING SYSTEM UL DETAILS SHALL BE AVAILABLE FOR SPECIAL INSPECTOR REVIEW.

ABBREVIATIONS:

ABBREVIATION	DESCRIPTION
AC	AIR CONDITIONING
AD	ACCESS DOOR
A.F.F.	ABOVE FINISHED FLOOR
BDD	BACKDRAFT DAMPER
BHP	BRAKE HORSE POWER
BOD	BOTTOM OF DUCT
BTU	BRITISH THERMAL UNIT
CAV	CONSTANT AIR VOLUME
CD	CEILING DIFFUSER AND/OR CONDENSATE DRAIN
COD	CABLE OPERATED DAMPER
CP	CONDENSATE PUMP
CU	CONDENSING UNIT
CR	CEILING RETURN
DN	DOWN
DP	DRIP PAN
DX	DIRECT EXPANSION
EAT	ENTERING AIR TEMPERATURE
EDH	ELECTRIC DUCT HEATER
EF	EXHAUST FAN
FC	FLEXIBLE CONNECTION
FCU	FAN COIL UNIT
FD/AD	FIRE DAMPER WITH ACCESS DOOR
FLA	FULL LOAD AMPS
FSD	FIRE SMOKE DAMPER
HP	HORSEPOWER
KW	KILOWATT
KWH	KILOWATT HOURS
LAT	LEAVING AIR TEMPERATURE
LD	LINEAR DIFFUSER (CEILING, WALL, SILL OR FLOOR) AND/OR LEAK DETECTOR
LRA	LOCKED ROTOR AMPS
LWT	LEAVING WATER TEMPERATURE
MBH	THOUSAND BTU PER HOUR
MD	MOTORIZED DAMPER
N.I.C	NOT IN THIS CONTRACT
N.T.S.	NOT TO SCALE
OA	OUTSIDE AIR
OAF	OUTSIDE AIR FAN
PSIG	POUNDS PER SQUARE INCH (GAUGE)
RG	RETURN GRILLE
RPM	REVOLUTIONS PER MINUTE
SD	SMOKE DETECTOR
SG	SUPPLY GRILLE
SS	STAINLESS STEEL
TD	TRANSFER DUCT
TX	TOILET EXHAUST
VD	VOLUME DAMPER
V.I.F.	VERIFY IN FIELD
WMS	WIRE MESH SCREEN

SYMBOL LIST:

SYMBOL	DESCRIPTION
	PATTERN DEFLECTOR
	SUPPLY DIFFUSER (FOR SIZE, TYPE, ETC. SEE AIR OUTLET SCHEDULE)
	DIFFUSER TAG (SEE AIR OUTLET SCHEDULE)
	INDICATES C.F.M.
	SUPPLY DIFFUSER (FOR SIZE, TYPE, ETC. SEE AIR OUTLET SCHEDULE)
	DIFFUSER TAG (SEE AIR OUTLET SCHEDULE)
	INDICATES C.F.M.
	RETURN REGISTER (FOR SIZE, TYPE, ETC. SEE AIR OUTLET SCHEDULE)
	TRANSFER OPENING ABOVE HUNG CEILING
	TRANSFER AIR GRILLE
	DOOR UNDERCUT
	DUCTWORK (SEE SPECIFICATIONS)
	CLEAR INSIDE DIMENSIONS (FIRST NUMBER INDICATES PLAN SIZE)
	SUPPLY GRILLE (FOR SIZE, TYPE, ETC. SEE AIR OUTLET SCHEDULE)
	DIFFUSER TAG (SEE AIR OUTLET SCHEDULE)
	INDICATES C.F.M.
	DUCT FLEXIBLE CONNECTION
	DUCTWORK WITH ACOUSTICAL LINING (DUCT SIZE NOTED INDICATES CLEAR INSIDE DIMENSION)
	ACOUSTICALLY LINED TRANSFER AIR DUCT WITH 1" A.L. & WMS
	ACCESS DOOR IN DUCT
	COMBINATION FIRE AND SMOKE DAMPER (FSD) WITH ACCESS DOOR & SMOKE DETECTOR/FIRE DAMPER (FD) WITH ACCESS DOOR
	DUCT VOLUME DAMPER
	CABLE OPERATED DAMPER TO BE USED FOR ALL SUPPLY AND RETURN DIFFUSERS IN SHEETROCK OR IN ACCESSIBLE CEILINGS.
	FUSIBLE LINK FIRE DAMPER WITH DUCT ACCESS DOOR (SD INDICATES SMOKE TYPE DAMPER, FSD INDICATES FIRE/SMOKE TYPE DAMPER. SEE SPECIFICATIONS)
	FIRE SMOKE DAMPER WITH ACCESS DOOR
	BRANCH TAKEOFF
	DUCT RISE CONNECTIONS
	DUCT DROP CONNECTIONS
	SUPPLY DUCTWORK UP
	RETURN DUCTWORK DOWN
	NEW THERMOSTAT
	TEMPERATURE SENSOR
	DUCT TYPE SMOKE DETECTOR
	MOTORIZED DAMPER
	CONTROL WIRING
	DIRECTION OF AIRFLOW
	SERVICE CLEARANCE

PIPING SYMBOL LIST

SYMBOL	DESCRIPTION
	MANUALLY OPERATED SHUTOFF VALVE
	CHECK VALVE
	AUTOMATIC MODULATING THREE-WAY CONTROL VALVE
	AUTOMATIC TWO-WAY SHUTOFF VALVE
	PRESSURE GAUGE
	FUTURE VALVED AND CAPPED CONNECTION
	Y-STRAINER W/ BLOWOFF VALVE
	THERMOMETER
	CONDENSATE PUMP
	LEAK DETECTOR
	PIPING DROP
	PIPING RISE
	OUTDOOR PIPE SUPPORTS / GUIDES
	UNIONS
	PIPE TEE
	PIPE GUIDE

DRAWING LIST:

NUMBER	DESCRIPTION
M-100	H.V.A.C. TITLE SHEET
M-101	H.V.A.C. SPECIFICATIONS SHEET 1 OF 3
M-102	H.V.A.C. SPECIFICATIONS SHEET 2 OF 3
M-103	H.V.A.C. SPECIFICATIONS SHEET 3 OF 3
M-300	H.V.A.C. GROUND FLOOR PLANS
M-400	H.V.A.C. GROUND FLOOR PIPING PLAN
M-600	H.V.A.C. SCHEDULES
M-700	H.V.A.C. DETAILS SHEET 1 OF 2
M-701	H.V.A.C. DETAILS SHEET 2 OF 2

DRAWING NOTATIONS:

SYMBOL	DESCRIPTION
	SEE REFERENCE NOTE APPLICABLE TO THIS DRAWING. NOTE NUMBER INDICATED BY NUMERAL IN DIAMOND.
	DETAIL REFERENCE TAG
	INDICATES DETAIL NUMBER
	INDICATES DRAWING NUMBER
	ELEVATION REFERENCE TAG
	INDICATES DETAIL NUMBER
	INDICATES DRAWING NUMBER
	POINT OF CONNECTION TO EXISTING
	POINT OF DISCONNECTION
	CUT AND CAP

sg

sweetgreen

3101 W. EXPOSITION BLVD.
LOS ANGELES, CALIFORNIA 90018

THESE DRAWINGS & SPECIFICATIONS ARE CONFIDENTIAL AND SHALL REMAIN THE SOLE PROPERTY OF SWEETGREEN CORPORATION. THEY SHALL NOT BE REPRODUCED (IN WHOLE OR IN PART), SHARED WITH THIRD PARTIES OR USED IN ANY MANNER ON OTHER PROJECTS OR EXTENSIONS TO THIS PROJECT WITHOUT THE PRIOR WRITTEN CONSENT OF SWEETGREEN CORPORATION. THESE DRAWINGS & SPECIFICATIONS ARE INTENDED TO EXPRESS DESIGN INTENT FOR A PROTOTYPICAL SWEETGREEN STORE WHICH IS SUBJECT TO CHANGE AT ANY TIME AND MAY NOT REFLECT ACTUAL SITE CONDITIONS. NEITHER PARTY SHALL HAVE ANY OBLIGATION OR LIABILITY TO THE OTHER (EXCEPT AS STATED ABOVE) UNTIL A WRITTEN AGREEMENT IS FULLY EXECUTED.

ARCHITECT OF RECORD:

O'NEIL LANGAN
ARCHITECTS

15 WEST 37TH STREET
15TH FLOOR
NEW YORK, NY 10018
PHONE: 212-279-2670
FAX: 212-279-2671

STAMP:

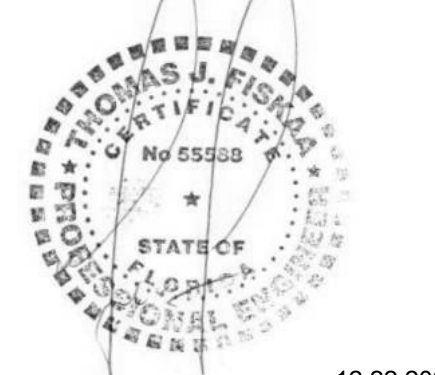

12.22.2021

PROJECT INFORMATION:
TAMPA HEIGHTS

PROJECT INFORMATION:
**301 West Palm Avenue
Tampa FL 33602**

DRAWN BY: XX
CHECKED BY: XX
PROJECT MANAGER: RC
SG DESIGN MANAGER: JM
SG CONSTR. MANAGER: JD
PROJECT NO: 221186
TEMPLATE VERSION: 06.01.2020

REVISIONS

REV.	DATE	DESCRIPTION
	11.09.2021	SG REVIEW
	11.23.2021	LL REVIEW
	12.22.2021	PERMIT SET
2	04.04.2022	REVISION 2
3	05.26.2022	IFC
4	06.21.2022	FIELD REV 01

H.V.A.C. TITLE SHEET

M-100

H.V.A.C. SPECIFICATIONS:

1. GENERAL
- A. THE "GENERAL CONDITIONS OF THE CONTRACT FOR CONSTRUCTION," AIA DOCUMENT A201, LATEST EDITION, AND THESE SPECIFICATIONS AS APPLICABLE ARE PART OF THIS CONTRACT.
- B. ALL APPLICABLE CODES, LAWS AND REGULATIONS GOVERNING OR RELATING TO ANY PORTION OF THIS WORK ARE HEREBY INCORPORATED INTO AND MADE A PART OF THESE SPECIFICATIONS, AND THEIR PROVISIONS SHALL BE CARRIED OUT BY THE CONTRACTOR WHO SHALL INFORM THE OWNER, PRIOR TO SUBMITTING A PROPOSAL, OF ANY WORK OR MATERIALS WHICH VIOLATE ANY OF THE ABOVE LAWS AND REGULATIONS. ANY WORK DONE BY THE CONTRACTOR CAUSING SUCH VIOLATION SHALL BE CORRECTED BY THE CONTRACTOR.
- C. INVESTIGATE EACH SPACE THROUGH WHICH EQUIPMENT MUST BE MOVED. WHERE NECESSARY, EQUIPMENT SHALL BE SHIPPED FROM MANUFACTURER IN SECTIONS OF SIZE SUITABLE FOR MOVING THROUGH AVAILABLE RESTRICTIVE SPACES. ASCERTAIN FROM BUILDING OWNER AT WHAT TIMES OF DAY EQUIPMENT MAY BE MOVED THROUGH ALL AREAS.
- D. DUCTWORK AND PIPING IS SHOWN DIAGRAMMATICALLY AND DOES NOT SHOW ALL OFFSETS, DROPS AND RISES OF RUNS. THE CONTRACTOR SHALL ALLOW IN HIS PRICE FOR ROUTING OF DUCTWORK AND PIPING TO AVOID OBSTRUCTIONS. EXACT LOCATIONS ARE SUBJECT TO APPROVAL OF ARCHITECT. COORDINATION WITH THE EXISTING SERVICES, INCLUDING THOSE OF OTHER TRADES IS REQUIRED.
- E. SUPPORT ALL DUCTWORK AND PIPING FROM BUILDING STRUCTURE AND/OR FRAMING IN AN APPROVED MANNER. WHERE OVERHEAD CONSTRUCTION DOES NOT PERMIT FASTENING OR SUPPORTS FOR EQUIPMENT, FURNISH ADDITIONAL FRAMING. INSERTS SHALL BE STEEL, SLOTTED TYPE AND FACTORY PAINTED. SINGLE ROD SHALL BE SIMILAR TO GRINNELL FIG. 281. MULTI-ROD SHALL BE SIMILAR TO FEE & MASON SERIES 9000 WITH END CAPS AND CLOSURE STRIPS. MAXIMUM LOADING INCLUDING PIPES, DUCTWORK CONTENTS AND COVERING SHALL NOT EXCEED 75% OF RATED INSERT CAPABILITY, WHEN SUPPORTING FROM BUILDING USE BEAM CLAMPS IN APPROVED MANNER.
- F. INSTALL WORK SO AS TO BE READILY ACCESSIBLE FOR OPERATION, MAINTENANCE AND REPAIR. MINOR DEVIATIONS FROM DRAWINGS MAY BE MADE TO ACCOMPLISH THIS, BUT CHANGES WHICH INVOLVE EXTRA COST SHALL NOT BE MADE WITHOUT APPROVAL.
- G. REMOVAL AND RELOCATION OF CERTAIN EXISTING WORK WILL BE NECESSARY FOR THE PERFORMANCE OF THE GENERAL WORK. ALL EXISTING CONDITIONS CANNOT BE COMPLETELY DETAILED ON THE DRAWINGS. THE CONTRACTOR SHALL SURVEY THE SITE AND INCLUDE ALL CHANGES IN MAKING UP THE WORK PROPOSAL.
- H. PLAN INSTALLATION OF NEW WORK AND CONNECTIONS TO EXISTING WORK TO ENSURE MINIMUM INTERFERENCE WITH REGULAR OPERATION OF EXISTING FACILITIES. ALL SYSTEM SHUTDOWNS AFFECTING OTHER AREAS SHALL BE COORDINATED WITH BUILDING OWNER. INSTALL ISOLATION VALVES AT POINT OF CONNECTION TO EXISTING PIPING. PROVIDE TEMPORARY DUCT CAPS AND/OR CONNECTIONS TO MINIMIZE SHUTDOWN TIME.
- I. CONNECT NEW WORK TO EXISTING WORK IN NEAT AND APPROVED MANNER. RESTORE EXISTING WORK DISTURBED WHILE INSTALLING NEW WORK TO ACCEPTABLE CONDITION AS DETERMINED BY ARCHITECT.
- J. DISCONNECT, REMOVE AND/OR RELOCATE EXISTING MATERIAL, EQUIPMENT AND OTHER WORK AS NOTED OR REQUIRED FOR PROPER INSTALLATION OF NEW SYSTEM.
- K. THE CONTRACTOR SHALL KEEP ALL EQUIPMENT AND MATERIALS, AND ALL PARTS OF THE BUILDING, EXTERIOR SPACES AND ADJACENT STREETS, SIDEWALKS AND PAVEMENTS, FREE FROM MATERIAL AND DEBRIS RESULTING FROM THE EXECUTION OF THIS WORK. EXCESS MATERIALS WILL NOT BE PERMITTED TO ACCUMULATE EITHER ON THE INTERIOR OR THE EXTERIOR.
- L. SEAL OPENINGS AROUND DUCTS AND PIPING THROUGH PARTITIONS, WALLS AND FLOORS (NOT IN SHAFTS) WITH MINERAL WOOL OR OTHER NONCOMBUSTIBLE MATERIAL.
- M. PROVIDE ALL NECESSARY FLASHING AND COUNTERFLASHING TO MAINTAIN THE WATERPROOFING INTEGRITY OF THIS BUILDING AS REQUIRED BY THE INSTALLATION OR REMOVAL OF PIPES, DUCTS, LOUVERS, CONDUIT, AND EQUIPMENT. PROVIDE EQUIPMENT CURBS AND DUNNAGE STEEL AS REQUIRED.
- N. ALL PRESENT MATERIAL, EQUIPMENT AND CONSTRUCTION DEBRIS TO BE REMOVED UNDER THIS CONTRACT SHALL BECOME THE PROPERTY OF THE CONTRACTOR WITH THE EXCEPTION OF SPECIFIC EQUIPMENT AND APPARATUS REQUESTED BY THE BUILDING REPRESENTATIVE, ARCHITECT OR AS NOTED TO BE RELOCATED ON THE DRAWINGS SHALL BE PROPERLY DISPOSED OF BY THIS CONTRACTOR.
- O. MATERIALS AND WORKMANSHIP, UNLESS OTHERWISE NOTED, SHALL BE IN ACCORDANCE WITH BUILDING STANDARDS.
- P. THE WORK IN THE BUILDING SHALL BE DONE WHEN AND AS DIRECTED, AND IN A MANNER SATISFACTORY TO THE OWNER. THE WORK SHALL BE PERFORMED SO AS TO CAUSE THE LEAST POSSIBLE INCONVENIENCE AND DISTURBANCE TO THE PRESENT OCCUPANTS.
- Q. THE CONTRACTOR'S PROPOSAL FOR ALL WORK SHALL BE PREDICATED ON THE PERFORMANCE OF THE WORK DURING REGULAR WORKING HOURS. WHEN SO DIRECTED, HOWEVER, THE CONTRACTOR SHALL INSTALL WORK IN OVERTIME AND THE ADDITIONAL COST TO BE CHARGED THEREFORE SHALL BE ONLY THE "PREMIUM" PORTION OF THE WAGES PAID.
- R. UNLESS OTHERWISE SPECIFICALLY SPECIFIED, INCLUDE ALL CUTTING AND PATCHING OF EXISTING FLOORS, WALLS, PARTITIONS AND OTHER MATERIALS IN THE EXISTING BUILDING. THE CONTRACTOR SHALL RESTORE THESE AREAS TO ORIGINAL CONDITION.
- S. REMOVABLE ACCESS TILE AND/OR ACCESS DOOR ARE REQUIRED IN HUNG CEILING, SHAFTS AND WALLS FOR ALL VOLUME AND FIRE DAMPERS, AUTOMATIC DAMPERS AND ALL OTHER MECHANICAL EQUIPMENT AND DEVICES. HVAC CONTRACTOR TO FURNISH ACCESS LOCATION REQUIREMENTS TO GENERAL CONTRACTOR. ACCESS TILE IDENTIFICATION: PROVIDE BUTTONS, TABS, AND MARKERS TO IDENTIFY LOCATION OF CONCEALED VALVES, DAMPERS AND EQUIPMENT.
- T. ALL EQUIPMENT SHALL HAVE AN MEA AND/OR BSA NUMBER. THIS INFORMATION MUST BE INCLUDED IN THE SUBMITTAL PACKAGE.
- U. ALL MATERIAL AND EQUIPMENT TO BE NEW UNLESS OTHERWISE NOTED AND SHALL BE IN ACCORDANCE WITH BUILDING STANDARDS.
- V. SUBMISSION OF A PROPOSAL SHALL BE CONSTRUED AS EVIDENCE THAT A CAREFUL EXAMINATION OF THE PORTIONS OF THE EXISTING BUILDING, EQUIPMENT, ETC., WHICH AFFECT THIS WORK, AND THE ACCESS TO SUCH SPACES, HAS BEEN MADE AND THAT THE CONTRACTOR IS FAMILIAR WITH EXISTING CONDITIONS AND DIFFICULTIES THAT WILL AFFECT THE EXECUTION OF THE WORK. LATER CLAIMS SHALL NOT BE MADE FOR LABOR, EQUIPMENT OR MATERIALS REQUIRED BECAUSE OF DIFFICULTIES ENCOUNTERED WHICH COULD HAVE BEEN FORESEEN DURING SUCH AN EXAMINATION. THE ON-SITE INSPECTION SHALL VERIFY EXISTING DUCTWORK, PIPING (SIZES, CLEARANCES, ETC) AND CONDITIONS.
- W. INSURANCE: IN ACCORDANCE WITH BUILDING REQUIREMENTS AND SHALL INCLUDE A HOLD HARMLESS CLAUSE FOR OWNER AND ENGINEER.
- X. THE FINAL ACCEPTANCE WILL BE MADE AFTER THE CONTRACTOR HAS ADJUSTED HIS EQUIPMENT, BALANCED THE VARIOUS SYSTEMS, DEMONSTRATED THAT IT FULFILLS THE REQUIREMENTS OF THE DRAWINGS AND SPECIFICATIONS AND HAS FURNISHED ALL THE REQUIRED CERTIFICATES OF INSPECTION AND APPROVAL.
- Y. SPECIFICATIONS ARE OF SIMPLIFIED FORM AND INCLUDE INCOMPLETE SENTENCES, WORDS OR PHRASES SUCH AS "THE CONTRACTOR SHALL," "SHALL BE," "FURNISH," "PROVIDE," "A," "THE," AND "ALL" HAVE BEEN OMITTED FOR BREVITY.
- Z. SUBSTITUTIONS ON EQUIPMENT WILL ONLY BE CONSIDERED BY THE ENGINEER OF RECORD (EOR) IF THE REQUEST IS PUT FORTH BY THE CONTRACTOR(S) IN A TIMELY MANNER (2 WEEKS PRIOR TO SUBMISSION OF BID), THE CONTRACTOR(S) SHALL REVIEW THE DOCUMENTS TO UNDERSTAND THE SCOPE OF THE EQUIPMENT FOR WHICH A SUBSTITUTION IS REQUESTED AND PROVIDE A SHOP DRAWING FROM THE ALTERNATE MANUFACTURER LISTED HEREIN FOR A FORMAL REVIEW BY THE EOR. ANY BREACH OF THE TERMS LISTED IN THIS SECTION WILL AUTOMATICALLY DISQUALIFY THE REQUEST FOR SUBSTITUTION.
- Z. DEFINITIONS:
- "PROVIDE": TO SUPPLY, INSTALL AND CONNECT UP COMPLETE AND READY FOR SAFE AND REGULAR OPERATION THE PARTICULAR WORK REFERRED TO UNLESS SPECIFICALLY OTHERWISE NOTED.
 - "INSTALL": TO ERECT, MOUNT AND CONNECT COMPLETE WITH RELATED ACCESSORIES.
 - "FURNISH" OR "SUPPLY": TO PURCHASE, PROCURE, ACQUIRE AND DELIVER COMPLETE WITH RELATED ACCESSORIES.
 - "WORK": LABOR, MATERIALS, EQUIPMENT, APPARATUS, CONTROLS, ACCESSORIES AND OTHER ITEMS REQUIRED FOR PROPER AND COMPLETE INSTALLATION.
 - "CONCEALED": EMBEDDED IN MASONRY OR OTHER CONSTRUCTION, INSTALLED IN FURRED SPACES, WITHIN DOUBLE PARTITIONS OR HUNG CEILING, IN TRENCHES, IN CRAWL SPACES, OR IN ENCLOSURES.
 - "EXPOSED": NOT INSTALLED UNDERGROUND OR "CONCEALED" AS DEFINED ABOVE.
 - "SIMILAR" OR "EQUAL": EQUAL IN MATERIALS, WEIGHT, SIZE, DESIGN AND EFFICIENCY OF SPECIFIED PRODUCT.
 - "BMS": BUILDING MANAGEMENT SYSTEM THAT CONTROLS THE ENTIRE HVAC SYSTEM AND ALL RELATED EQUIPMENT REQUIRED TO ACHIEVE THE SEQUENCE OF OPERATIONS.
2. SCOPE OF WORK
- A. THE WORK UNDER CONTRACT INCLUDES ALL LABOR, MATERIALS AND APPLIANCES NECESSARY FOR THE FURNISHING, INSTALLING AND TESTING, COMPLETE AND READY FOR SAFE OPERATION OF THE SYSTEMS. WORK SHALL BE INSTALLED IN A NEAT, WORKMANLIKE MANNER.
- B. THE CONTRACTOR SHALL GIVE NECESSARY NOTICE, FILE DRAWINGS AND SPECIFICATIONS WITH THE DEPARTMENT HAVING JURISDICTION, OBTAIN PERMITS OR LICENSES NECESSARY TO CARRY OUT THIS WORK AND PAY ALL FEES THEREFORE. THE CONTRACTOR SHALL ARRANGE FOR INSPECTION AND TESTS OF ANY OR ALL PARTS OF THE WORK IF SO REQUIRED BY AUTHORITIES AND PAY ALL CHARGES FOR SAME. THE CONTRACTOR SHALL PAY ALL COSTS FOR, AND FURNISH TO THE OWNER BEFORE FINAL BILLING, ALL CERTIFICATES NECESSARY AS EVIDENCE THAT THE WORK INSTALLED CONFORMS WITH ALL REGULATIONS WHERE THEY APPLY TO THIS WORK.
- C. THE CONTRACTOR SHALL FURNISH A WRITTEN GUARANTEE TO REPLACE OR REPAIR PROMPTLY AND ASSUME RESPONSIBILITY FOR ALL EXPENSES INCURRED FOR ANY WORKMANSHIP AND EQUIPMENT IN WHICH DEFECTS DEVELOP WITHIN ONE YEAR FROM THE DATE OF FINAL CERTIFICATE FOR PAYMENT AND/OR FROM DATE OF ACTUAL USE OF EQUIPMENT OR OCCUPANCY OF SPACES, BY OWNER, INCLUDED UNDER THE VARIOUS PARTS OF THE WORK, WHICHEVER DATE IS EARLIER. THIS WORK SHALL BE DONE AS DIRECTED BY THE OWNER. THIS GUARANTEE SHALL ALSO PROVIDE THAT WHERE DEFECTS OCCUR, THE CONTRACTOR WILL ASSUME RESPONSIBILITY FOR ALL EXPENSES INCURRED IN REPAIRING AND REPLACING WORK OF OTHER TRADES AFFECTED BY DEFECTS, REPAIRS OR REPLACEMENTS IN EQUIPMENT SUPPLIED BY THE CONTRACTOR.
- D. CONTROLLED INSPECTION BY A LICENSED PROFESSIONAL ENGINEER TO BE HIRED BY THIS CONTRACTOR ON BEHALF OF OWNER.
- E. PRIOR TO THE INSTALLATION OF ANY WORK AND PROCUREMENT OF EQUIPMENT PROVIDE COMPLETE SET OF COORDINATED SHOP DRAWINGS OF ALL NEW AND EXISTING EQUIPMENT, DUCTWORK, PIPING AND CONTROL SYSTEMS INDICATING CAPACITY DIMENSIONS AND SEQUENCE OF OPERATION FOR WRITTEN APPROVAL BY THE ARCHITECT AND ENGINEER.
- F. CONTRACTOR SHALL ATTAIN THE SERVICES OF A LICENSED PROFESSIONAL ENGINEER (PE) TO PREPARE AND SUBMIT ALL FABRICATION DRAWINGS, SIGNED AND SEALED BY THE AFORESAID PE, PERTAINING TO THE NEW STEAM SERVICE TO CONSOLIDATED EDISON FOR APPROVAL. THE CONTRACTOR SHALL PROVIDE ALL DRAWINGS, CALCULATIONS AND DOCUMENTATION REQUIRED BY CONSOLIDATED EDISON PURSUANT TO THEIR STANDARDS AND REGULATIONS FOR SUCH WORK.
3. SHOP DRAWINGS
- A. INDICATE ON EACH SUBMISSION: PROJECT NAME AND LOCATION, ARCHITECT AND ENGINEER, ITEM IDENTIFICATION AND APPROVAL STAMP OF PRIME CONTRACTOR.
- B. SUBMISSIONS:
- SUBMISSIONS 11 IN. X 17 IN. OR SMALLER: IF THE SUBMISSION IS A CATALOG CUT, THEN THE CONTRACTOR SHALL SUBMIT ONE ORIGINAL AND TWO COPIES. OTHERWISE, THE CONTRACTOR SHALL SUBMIT WATER SOURCE HEAT PUMP UNITS, THE ARCHITECT WILL SUBMIT ONE ORIGINAL AND ONE COPY (TWO COPIES WHEN NO ORIGINAL IS RECEIVED) TO THE ENGINEER. ALL CATALOG CUTS SHALL BE COMPLETE.
 - SUBMISSIONS LARGER THAN 11 IN. X 17 IN.: SUBMIT TWO PRINTS AND ONE PAPER SEPIA TO THE ARCHITECT. THE ARCHITECT WILL FORWARD ONE PRINT AND THE PAPER SEPIA TO THE ENGINEER.
- C. SUBMIT SHOP DRAWINGS FOR HVAC EQUIPMENT LISTED IN THE MECHANICAL SCHEDULES AND DRAWINGS SUCH AS, BUT NOT LIMITED TO THE FOLLOWING:
- DUCTWORK & PIPING LAYOUT.
 - VIBRATION ISOLATION.
 - DUCTWORK & PIPING INSULATION.
 - AIR AND WATER BALANCING REPORTS.
 - WATER SOURCE HEAT PUMP UNITS.
 - ELECTRIC DUCT HEATERS.
 - AIR CURTAIN.
 - DUCT-MOUNTED SMOKE DETECTORS.
 - INLINE FANS.
 - FIRE SMOKE DAMPERS.
 - FIRE DAMPERS.
 - AIR OUTLETS.
 - LEAK DETECTORS.
 - SEQUENCE OF OPERATIONS.
4. AS-BUILTS AND EQUIPMENT OPERATION INSTRUCTIONS
- A. ON COMPLETION AND ACCEPTANCE OF WORK, THIS CONTRACTOR SHALL FURNISH WRITTEN INSTRUCTIONS, EQUIPMENT MANUALS AND DEMONSTRATE TO THE OWNER THE PROPER OPERATION AND MAINTENANCE OF ALL EQUIPMENT AND APPARATUS FURNISHED UNDER THIS CONTRACT.
- B. THESE INSTRUCTIONS SHALL BE TYPED ON 8-1/2 IN. X 11 IN. PAPER AND BOUND IN THREE-RING BINDERS WITH CLEAR ACETATE COVERS. THE CONTRACTOR SHALL GIVE THREE COPIES OF THE INSTRUCTIONS TO THE OWNER AND ONE COPY TO THE ENGINEER.
- C. THE INSTRUCTION BOOKLET SHALL BE ORGANIZED IN SECTIONS, WITH ONE SECTION PER SYSTEM. THE COVER OF THE INSTRUCTION BOOKLET SHALL BEAR THE NAME, ADDRESS AND PHONE NUMBER OF THE PROJECT, ARCHITECT, ENGINEER, MECHANICAL CONTRACTOR AND SUBCONTRACTORS.
- D. REPRODUCIBLE "AS-BUILT" DRAWINGS INDICATING AS INSTALLED CONDITIONS SHALL BE PROVIDED TO THE ARCHITECT AFTER COMPLETION OF THE INSTALLATION.
5. SHEET METAL WORK
- A. EXCEPT AS OTHERWISE SHOWN OR NOTED, ALL DUCTWORK AND OTHER SHEET METAL WORK SHALL BE GALVANIZED SHEET STEEL AND SHALL BE INSTALLED IN ACCORDANCE WITH THE LATEST EDITION OF SHEET METAL AND AIR CONDITIONING CONTRACTORS NATIONAL ASSOCIATION, INC. DUCT CONSTRUCTION STANDARDS, PRESSURE CLASSIFICATION 2 IN. W.G.
- B. FOR DUCTWORK SYSTEMS WHERE AIR MOVING EQUIPMENT (I.E. FANS, AIR HANDLERS ETC.) ASSOCIATED WITH THAT SYSTEM IS IN EXCESS OF 2" WG PRESSURE CLASS, PROVIDE THE REQUIRED PRESSURE CLASS DUCTWORK PURSUANT TO SMACNA STANDARDS. PRESSURE CLASS OF DUCT SYSTEM SHALL BE THE CLOSEST PRESSURE RATING HIGHER THAN THAT OF THE FANS STATIC PRESSURE RATING. REFER TO MECHANICAL SCHEDULES FOR PRESSURE INFORMATION.
- C. VOLUME DAMPERS: GALVANIZED STEEL, PER SMACNA "LOW VELOCITY MANUAL, EXCEPT PROVIDE BEARING AT ONE END OF DAMPER ROD AND QUADRANT, WITH LEVER AND LOCKSCREW AT OTHER END. FOR INSULATED DUCTS, QUADRANTS MOUNTED ON COLLAR TO CLEAR INSULATION. INSTALL WITH LEVERS ACCESSIBLE.
- D. DUCT ACCESS DOORS (DOES NOT APPLY TO KITCHEN EXHAUST ACCESS DOORS): INSULATED OR UNINSULATED, SAME AS DUCT.
- PROVIDE MINIMUM 20 IN. X 14 IN. ON MAIN DUCTS, AND 12 IN. X 6 IN. ON BRANCH DUCTS, UNLESS OTHERWISE APPROVED. AT FIRE DAMPERS, AND AT ALL DUCT ACCESSORIES SUCH AS FIRE DAMPERS, COMBINATION FIRE AND SMOKE DAMPERS, DUCT SMOKE DETECTORS, MOTORIZED DAMPERS, LOUVERS, DUCT MOUNTED TEMPERATURE SENSORS, AND ENTHALPHY SENSORS.
 - ALL ACCESS DOORS TO BE HINGED, WITH LATCH SIMILAR TO VENTLOCK NO. 100.
- E. ALL DUCTWORK RISERS INSTALLED OUTDOORS SHALL BE COMPOSED OF WEATHERPROOF MATERIALS OR FINISHED WITH A WEATHERPROOF COATING ALONG THE ENTIRE OUTDOOR RUN.
- F. FLEXIBLE CONNECTIONS: NEOPRENE-COATED GLASS FABRIC, 30 OZ PER SQ YD WITH SEWED AND CEMENTED SEAMS, SIMILAR TO VENT FABRICS. PROVIDE WITH METAL COLLARS. ALLOW MINIMUM MOVEMENT OF 1 IN.
- G. TURNING VANES: GALVANIZED STEEL SMALL DOUBLE-THICKNESS VANES WITH 2 IN. INSIDE RADIUS.
- H. COMBINATION FIRE AND SMOKE DAMPERS: UL LISTED, GALVANIZED STEEL CONSTRUCTION MULTI-BLADED TYPE, EQUIPPED WITH FUSIBLE LINK CONFORMING TO NFPA STANDARD 90A, SIMILAR TO RUSKIN MODEL FSD 60 FOR 1-1/2 HOUR RATING. SEE PLANS FOR MORE INFORMATION.
- I. ALL DUCT DIMENSIONS INDICATED ON PLANS ARE INSIDE CLEAR DIMENSIONS.
- J. AUTOMATIC DAMPERS: COMPLETE WITH LINKAGE AND ELECTRIC OPERATOR. OPPOSED BLADE DAMPER OR GALVANIZED STEEL MIN. 4 IN., MAX. 8 IN. WIDE WITH COMPRESSIBLE EDGE SEALS TO PREVENT LEAKAGE. FACTORY-ASSEMBLE STEEL LINKAGE AND SHAFT WITH NYLON OR OIL-IMPREGNATED BRONZE BEARINGS. MOTOR WITH SUFFICIENT POWER TO LIMIT LEAKAGE TO 10 CFM PER SQ FT. LINKAGE TO WITHSTAND LOAD EQUAL TO TWICE MAXIMUM OPERATING FORCE WITHOUT DEFLECTION. DAMPER MOUNTED IN WELDED STEEL CHANNEL FRAME.
- K. WIRE MESH SCREEN (WMS): NO. 16 USSG, 1/2" SQUARE MESH, IN 1 IN. WIDE GALVANIZED STEEL ENCLOSING FRAME. FLANGED DUCT OPENING TO RECEIVE FRAME.
- L. USE OF FLEXIBLE DUCT IS NOT ALLOWED.
- M. CONTRACTOR SHALL HIRE STRUCTURAL ENGINEER TO ANALYZE DUCTWORK HANGING AND SUPPORTS AND CONNECTION TO EXISTING STRUCTURE.
6. NOISE CONTROL
- A. ALL ROOM NC LEVELS SHALL BE 35 OR LESS.
7. TESTING AND BALANCING
- A. ALL DUCTWORK SHALL BE TESTED AS PER BUILDING RULES AND REGULATIONS.
- B. AIR BALANCING SHALL BE ACCOMPLISHED BY ADJUSTMENT OF FANS AND BRANCH DAMPERS FOR MAJOR ADJUSTMENTS. ADJUSTMENT OF TERMINAL DAMPERS AND DEVICES SHALL BE FOR TRIM OR MINOR ADJUSTMENT ONLY. THIS SHALL BE DONE TO PERMIT THE LEAST NOISE GENERATION TO THE SPACE WHILE PROVIDING THE REQUIRED AMOUNT OF AIR PER THE MECHANICAL DRAWINGS.
8. INSULATION - GENERAL REQUIREMENTS
- A. ALL INSULATION MATERIALS, INCLUDING JACKETS, FACING, ADHESIVE, COATINGS, AND ACCESSORIES ARE TO BE FIRE HAZARD RATED AND LISTED BY UNDERWRITERS LABORATORIES, INC. USING STEINER TUNNEL TEST METHOD FOR FIRE HAZARD CLASSIFICATION OF BUILDING MATERIALS, STANDARD UL 723 (ASTM E-84), (ASA A2-5-1963), FLAMESPREAD: MAXIMUM 25. FUEL CONTRIBUTED AND SMOKE DEVELOPED: MAXIMUM 50. FLAMEPROOFING TREATMENTS SUBJECT TO DETERIORATION FROM MOISTURE OR HUMIDITY ARE NOT ACCEPTABLE.
- B. ALL INSULATION MATERIALS AND THICKNESSES SHALL COMPLY WITH THE LATEST EDITION (I.E. THE ADDITION IN EFFECT AT THE ANTICIPATED STATE DATE OF CONSTRUCTION) OF THE FLORIDA STATE ENERGY CONSERVATION CONSTRUCTION CODE AND SUBSEQUENT ADDENDA.
- C. ALL FACINGS SHALL BE PAINTABLE. COLOR(S) SHALL BE AS SPECIFIED BY ARCHITECT.
- D. DEFINITIONS:
- EXPOSED: INDOOR DUCTS, PIPING OR EQUIPMENT LOCATED IN MECHANICAL EQUIPMENT ROOMS AND IN AREAS WHICH WILL BE VISIBLE WITHOUT REMOVING CEILING OR OPENING ACCESS PANELS.
 - CONCEALED: INDOOR DUCTS, PIPING OR EQUIPMENT WHICH IS NOT EXPOSED.
 - OUTDOOR: DUCTS, PIPING OR EQUIPMENT WHICH IS EXPOSED TO THE WEATHER.
9. DUCTWORK INSULATION
- A. INSULATE ALL DUCTWORK IN ACCORDANCE WITH INSULATION SCHEDULE EXCEPT AS OTHERWISE NOTED. INSULATION MATERIALS AND THICKNESSES SHALL COMPLY WITH THE LATEST EDITION OF THE FLORIDA ENERGY CONSERVATION CODE, (AT THE TIME OF ANTICIPATED CONSTRUCTION DATE).
- INSULATION SCHEDULE - DUCTWORK
- | SERVICE | LOCATION | THICKNESS | MATERIAL | FINISH |
|---------------|-----------|-----------|----------|-----------|
| SUPPLY/RETURN | CONCEALED | 1-1/2" | D-1 | VAPORSEAL |
| SUPPLY/RETURN | EXPOSED | 1-1/2" | D-2 | VAPORSEAL |
| OUTSIDE AIR | ALL | 3" | D-4 | VAPORSEAL |
- B. DUCTWORK NOT REQUIRED TO BE THERMALLY INSULATED:
- WHERE SOUNDLINING IS OF MINIMUM THICKNESS SPECIFIED FOR INSULATION.
 - AIR CONDITIONING RETURN AIR DUCTWORK EXPOSED IN AIR CONDITIONED SPACES AND INSTALLED IN HUNG CEILING'S WHERE SPACE IMMEDIATELY ABOVE AND BELOW ARE BOTH AIR CONDITIONED.
 - DUMBWAITER VENT DUCT
- C. MATERIAL:
- TYPE D-1: MINIMUM 1-LB/CFUFT. DENSITY FIBERGLASS BLANKET, MAXIMUM 0.27 K-FACTOR AT 75 DEG F MEAN TEMPERATURE WITH FACTORY-APPLIED FOIL-SKIRM-KRAFT VAPOR RETARDANT FACING SIMILAR TO OWENS CORNING SOFTFR FRK OR AN APPROVED EQUAL.
 - TYPE D-2: FIBERGLASS LINER. THE MAX. K FACTOR SHALL BE 0.23 AT 75° F MEAN TEMPERATURE. THE INSULATION SHALL BE PROVIDED WITH A FACTORY-APPLIED ALL PURPOSE OR ALL SERVICE FACING. THE INSULATION SHALL BE EQUAL TO JONS MANVILLE LINACOUSTIC.
- D. INSTALLATION:
- FIBERGLASS BLANKET: 2 IN. LAP STRIPS AT ALL SEAMS. SECURE BOTTOM OF ALL DUCTS OVER 24 IN. WIDE WITH MIN. 2 ROWS OF WELD PINS 12 IN. ON CENTER. SECURE ALL SEAMS WITH FOIL VAPOR BARRIER TAPE AND VAPORSEAL ADHESIVE.
 - FIBERGLASS LINER: LINER SHALL BE ADHERED TO THE SHEET METAL WITH FULL COVERAGE OF AN APPROVED ADHESIVE THAT CONFORMS TO ASTM 916. AND ALL EXPOSED LEADING EDGES AND TRANSVERSE JOINTS SHALL BE COATED WITH PERMACOTE FACTORY-APPLIED OR FIELD APPLIED EDGE COATING AND SHALL BE NEATLY BUTTED WITHOUT GAPS. METAL NOSINGS SHALL BE SECURELY INSTALLED OVER TRANSVERSELY ORIENTED LINER EDGES FACING THE AIRSTREAM AT FORWARD DISCHARGE AND AT ANY POINT WHERE LINED DUCT IS PRECEDED BY UNLINED DUCT. LINER SHALL BE ADDITIONALLY SECURED WITH MECHANICAL FASTENERS SPACED PER MANUFACTURERS RECOMMENDATION. THE PIN LENGTH SHOULD BE SUCH AS TO HOLD THE MATERIAL FIRMLY IN PLACE WITH MINIMUM COMPRESSION OF THE MATERIAL.
10. PIPING INSULATION:
- A. INSULATE ALL PIPING IN ACCORDANCE WITH INSULATION SCHEDULE EXCEPT AS OTHERWISE NOTED.
- INSULATION SCHEDULE - PIPING
- | SERVICE | SIZE | THICKNESS | MATERIAL | FINISH |
|---------|--------------|-----------|----------|-----------|
| <40°F | <1" | 1/2" | P-1 | VAPORSEAL |
| <40°F | 1" TO <4" | 1" | P-1 | VAPORSEAL |
| <40°F | ≥8" | 1 1/2" | P-1 | VAPORSEAL |
| 40-60°F | <1 1/2" | 1/2" | P-1 | VAPORSEAL |
| 40-60°F | 1 1/2" TO 8" | 1" | P-1 | VAPORSEAL |



sweetgreen
3101 W. EXPOSITION BLVD.
LOS ANGELES, CALIFORNIA 90018

THESE DRAWINGS & SPECIFICATIONS ARE CONFIDENTIAL AND SHALL REMAIN THE SOLE PROPERTY OF SWEETGREEN CORPORATION. THEY SHALL NOT BE REPRODUCED (IN WHOLE OR IN PART), SHARED WITH THIRD PARTIES OR USED IN ANY MANNER ON OTHER PROJECTS OR EXTENSIONS TO THIS PROJECT WITHOUT THE PRIOR WRITTEN CONSENT OF SWEETGREEN CORPORATION. THESE DRAWINGS & SPECIFICATIONS ARE INTENDED TO EXPRESS DESIGN INTENT FOR A PROTOTYPICAL SWEETGREEN STORE WHICH IS SUBJECT TO CHANGE AT ANY TIME AND MAY NOT REFLECT ACTUAL SITE CONDITIONS. NEITHER PARTY SHALL HAVE ANY OBLIGATION OR LIABILITY TO THE OTHER EXCEPT AS STATED ABOVE UNTIL A WRITTEN AGREEMENT IS FULLY EXECUTED.

ARCHITECT OF RECORD:
O'NEIL LANGAN
ARCHITECTS
15 WEST 37TH STREET
15TH FLOOR
NEW YORK, NY 10018
PHONE: 212-279-2670
FAX: 212-279-2671

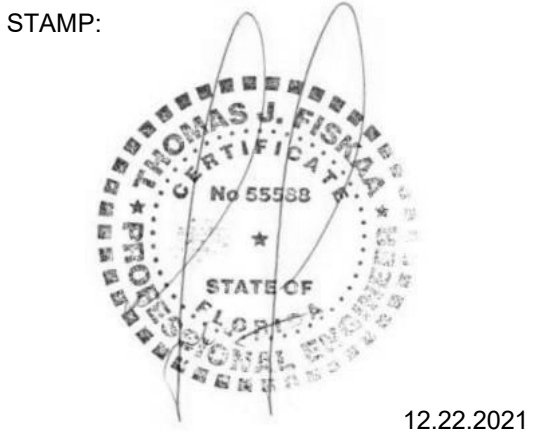

PROJECT INFORMATION:
TAMPA HEIGHTS
301 West Palm Avenue
Tampa FL 33602

DRAWN BY: XX
CHECKED BY: XX
PROJECT MANAGER: RC
SG DESIGN MANAGER: JM
SG CONSTR. MANAGER: JD
PROJECT NO: 221186
TEMPLATE VERSION: 06.01.2020

REV.	DATE	DESCRIPTION
	11.09.2021	SG REVIEW
	11.23.2021	LL REVIEW
	12.22.2021	PERMIT SET
2	04.04.2022	REVISION 2
3	05.26.2022	IFC
4	06.21.2022	FIELD REV 01

H.V.A.C.
SPECIFICATIONS
SHEET 1 OF 3

M-101

H.V.A.C. SPECIFICATIONS:

- B. MATERIAL:**
- 1) TYPE P-1: MINIMUM 4 LB DENSITY MOLDED FIBERGLASS, MAXIMUM 0.23 K-FACTOR AT 75 DEG F MEAN TEMPERATURE WITH FACTORY-APPLIED FIRE-RETARDANT FOIL-SKIRM -KRAFT FACING. ALL SERVICE JACKET. SIMILAR TO OWENS-CORNING 650 ASJ.
 - 2) TYPE P-3: MINIMUM 4 LB DENSITY MOLDED FIBERGLASS FITTING, MAXIMUM 0.23 K-FACTOR AT 75 DEG F MEAN TEMPERATURE SIMILAR TO EPOLUX HAMFAB MOLDED FITTINGS.
 - 3) TYPE P-4: MINIMUM 1 LB DENSITY FIBERGLASS FITTING INSERTS, MAXIMUM 0.28 K-FACTOR AT 75 DEG F MEAN TEMPERATURE SIMILAR TO MANVILLE H-HO TEMP INSULATION INSERTS.
 - 4) TYPE P-6: MINIMUM 6 LB MOLDED FOAMED PLASTIC. MAXIMUM 0.27 K-FACTOR AT 75 DEG F MEAN TEMPERATURE. MAXIMUM 0.17 PERMEANCE. SIMILAR TO ARMSTRONG ARMAFLEX II.
- H. FINISH:**
- 1) TYPE F-1: FITTING COVER, MOLDED WHITE PVC JACKET, UL CLASS 1, MAXIMUM PERMEANCE 0.05 SIMILAR TO MANVILLE ZESTRON.
 - 2) TYPE F-2: WHITE VAPOR BARRIER COATING WITH 10X10 OR 20X20 MESH WHITE GLASS, POLYESTER OR NYLON CLOTH REINFORCING MEMBRANE, MINIMUM 31 MIL DRY FILM THICKNESS, SIMILAR TO FOSTER TITE-FIT, UL LABEL.
 - 3) TYPE F-4: ALUMINUM JACKETING WITH MINIMUM 0.016 IN. WALL THICKNESS AND LONGITUDINAL JOINTS WITH LOCK SEAMS.
 - 4) TYPE F-6: ALL PURPOSE JACKET WITH LONGITUDINAL TAPE STRIPPING TO PROTECT INSULATION, SIMILAR TO JOHNS MANVILLE APJ.
- I. INSTALLATION:**
- 1) BEFORE APPLYING INSULATION ALL PRESSURE AND LEAK TESTS SHALL BE COMPLETED AND APPROVED.
 - 2) ALL INSULATION SHALL BE BUTTED FIRMLY TOGETHER. PROVIDE 2 IN. LAMP STRIPS AT ALL SEAMS SECURED WITH ADHESIVE. USE VAPOR BARRIER TAPE AND VAPORSEAL ADHESIVE WHERE REQUIRED. STAPLES NOT PERMITTED. REFRIGERANT PIPING INSULATION SHALL HAVE MITERED FITTINGS.
 - 3) ALL INSULATION AND VAPOR BARRIERS SHALL BE CONTINUOUS PASSING THROUGH SLEEVES, HANGERS, ETC., OR OTHER OPENINGS. PROVIDE SADDLES OR SHIELDS FOR PROTECTION.
 - 4) INSULATION FOR STRAINERS OR OTHER FITTINGS OR ACCESSORIES REQUIRING SERVICING OR INSPECTION SHALL HAVE INSULATION REMOVABLE AND REPLACEABLE WITHOUT DAMAGE.
- 11. PIPING - GENERAL REQUIREMENTS**
- A. COMPLETE WITH: PIPE, FITTINGS, VALVES, STRAINERS, MOTORIZED VALVE OPERATORS, STRAINERS, HANGERS, SUPPORTS, GUIDE, SLEEVES, AND ACCESSORIES. ALL WATER AND STEAM PIPING TO BE MINIMUM 3/4".**
- B. ALL ITEMS SHALL BE FURNISHED AND INSTALLED IN ACCORDANCE WITH THE LATEST EDITIONS OF THE FOLLOWING CODES AND STANDARDS:**
- 1) AMERICAN SOCIETY OF MECHANICAL ENGINEERS (ASME).
 - 2) AMERICAN SOCIETY FOR TESTING AND MATERIALS (ASTM).
 - 3) AMERICAN NATIONAL STANDARDS INSTITUTE (ANSI).
 - 4) MANUFACTURERS STANDARDIZATION SOCIETY OF THE VALVE AND FITTING INDUSTRY (MS).
- C. ALL PRESSURIZED PIPING TO BE TESTED HYDROSTATICALLY TO 150 PSI OR 150% OF OPERATING PRESSURE, WHICHEVER IS GREATER, BUT NEVER EXCEED TEST PRESSURE ANSI B16.1 BASIS. TEST DURATION TO BE 4 HOURS WITH NO PRESSURE CHANGE CORRECTED FOR TEMPERATURE CHANGE. REPAIR OR REPLACE LEAKS OR DEFECTS WITHOUT ADDITIONAL COST.**
- D. PROVIDE DIELECTRIC FITTINGS WHERE DISSIMILAR METALS ARE TO BE JOINED.**
- E. PIPE SUPPORTS:**
- 1) PROVIDE ADEQUATE SUPPORT FOR PIPE AND CONTENTS TO PREVENT SAGGING, VIBRATION, OR SWAYING AND ALLOW FOR EXPANSION AND CONTRACTION. PROVIDE SUPPLEMENTAL STEEL AS REQUIRED WHERE STRUCTURE CANNOT SUPPORT POINT LOADS.
 - 2) HORIZONTAL PIPING TO BE SUPPORTED BY FORGED STEEL ADJUSTABLE CLEVIS TYPE HANGER. MAXIMUM SPACING AS FOLLOWS:
 - a. STEEL 1 IN. AND SMALLER: 7 FT.
 - b. STEEL 1-1/4 IN. AND LARGER: 10 FT.
 - c. COPPER 3 IN. AND SMALLER: 7 FT.
 - d. ADDITIONAL SUPPORTS AT CHANGES IN DIRECTION, RUNOUTS, AND CONCENTRATED LOADS DUE TO VALVES, ETC.
 - 3) VERTICAL PIPING:
 - a. BASE ELBOW SUPPORT WITH BEARING PLATE ON STRUCTURAL SUPPORT.
 - b. GUIDES AT EVERY SECOND FLOOR (SPACING NOT TO EXCEED 25 FT).
 - c. TOP SUPPORT HANGER OR SADDLE IN HORIZONTAL CONNECTION WITH PROVISIONS FOR EXPANSION.
 - d. INTERMEDIATE STEEL RISER CLAMP SUPPORT BOLTED AND WELDED TO PIPE BEARING ON STRUCTURAL STEEL OR BEARING PLATE AT FLOOR.
- F. PIPING, VALVES AND FITTINGS TO BE INSULATED:**
- 1) LOW TEMPERATURE PIPING SYSTEMS - 40 TO 100 DEG F INCLUDING:
 - a. CONDENSATE DRAIN PIPING.
 - b. MAKE UP WATER (COORDINATE WITH PLUMBING SPECIFICATIONS)
 - c. REFRIGERANT PIPING
 - d. CONDENSER WATER
- 12. LOW TEMPERATURE WATER SYSTEMS, BELOW 100 PSIG, -20 TO 200 DEG F OPERATING TEMPERATURES.**
- A. PIPE:**
- 1) COPPER, TYPE K, HARD DRAWN IN ACCORDANCE WITH ASTM B88.
- B. FITTINGS:**
- 1) 2 IN. AND SMALLER: 125 LB WSP CAST IRON THREADED FITTINGS SHALL BE IN ACCORDANCE WITH ANSI B16.4., CAST IRON FLANGED FITTINGS SHALL BE IN ACCORDANCE WITH ANSI B16.1.
 - 2) 2-1/2 IN. AND LARGER WELDED: BUTT WELD FITTINGS SAME WEIGHT AS PIPING AND IN ACCORDANCE WITH ANSI B16.9.
- 3) COPPER: BRAZED.**
- C. VALVES:**
- 1) BALL VALVES:
 - a. 2 IN. AND SMALLER: BRONZE THREADED ENDS. USE OF APOLLO VALVES IS NOT PERMITTED.
 - 2) SILENT CHECK VALVES, SPRING LOADED, GLOBE TYPE, FLANGED: TO 250 PSIG CHECK VALVES SHALL BE IRON BODY, BRONZE TRIM. SIMILAR TO MUESSCO TYPE 103AP OR 107-AP.
 - 3) LUBRICATED PLUG VALVES:
 - a. SCREWED ENDS UP TO 2 IN., FLANGED 2-1/2 IN. AND LARGER.
 - b. SYSTEM LESS THAN 100 PSIG, VALVE SHALL BE MINIMUM 200 LB WOG CLASS CAST IRON BODY. ROCKWELL-NORDSTROM NUMBERS 114, 115, 185 AND 149.
 - 4) Y-TYPE STRAINERS:
 - a. PROVIDE SCREWED ENDS TO 2 IN. AND FLANGED 2-1/2 IN. AND LARGER WITH BODY AS FOLLOWS: TO 100 PSIG: 125 LB WSP CLASS, CAST IRON.
 - b. SCREENS TO BE 316 STAINLESS STEEL.
 - c. PROVIDE SCREWED WITH FACED CAP, STRAIGHT THREAD AND GASKET, SIMILAR TO MUELLER STEAM SPECIALTY MUESSCO NO. 11. PROVIDE FLANGED WITH BOLTED COVER SIMILAR TO MUELLER STEAM SPECIALTY MUESSCO NO. 751 OR NO. 752.
- D. PROVIDE 1/2 IN. DRAIN VALVE WITH CAPPED HOSE CONNECTION AT ALL LOW POINTS. PROVIDE 3/4 IN. GATE VALVE TO DRAIN SYSTEMS IN EQUIPMENT ROOMS.**
- E. PROVIDE MANUAL AIR VENTS LINE SIZE AIR CHAMBER WITH 1/2 IN. GLOBE VALVE AT ALL HIGH POINTS AND WHERE FLOW DIRECTION CHANGES FROM HORIZONTAL TO DOWNWARD.**
- F. PITCH WATER PIPING EXCEPT AS NOTED:**
- 1) UP TO 1 IN.: 1 IN. IN 40 FT.
 - 2) 1-1/2 IN. AND LARGER: 1 IN. IN 100 FT.
- 13. CONDENSATE DRAIN PIPING**
- A. PIPE: ASTM B88, HARD DRAWN COPPER TUBING TYPE "K".**
- B. FITTINGS: BRAZED.**
- C. PITCH, EXCEPT AS NOTED:**
- 1) 1 IN. IN 4 FT PREFERRED.
 - 2) 1 IN. IN 8 FT MINIMUM.
- D. SWING CHECK VALVES: AT CONDENSATE PUMP DISCHARGE. 300 LB WOG, BRONZE BODY SOLDER ENDS, REGIND BRONZE DISC TO BE USED WITH COPPER TUBING. JENKINS FIG. 1222.**
- 14. BASE BUILDING WATER TREATMENT CONTRACTOR IS TO BE UTILIZED FOR ALL WATER TREATMENT.**
- 15. VIBRATION ISOLATION**
- A. GENERAL:**
- 1) PROVIDE ISOLATION FOR EQUIPMENT, PIPING AND DUCTWORK.
 - 2) INSTALL IN ACCORDANCE WITH MANUFACTURER'S INSTRUCTIONS.
 - 3) PROVIDE LEVELING DEVICES AND APPROVED RESILIENT RESTRAINING DEVICES AS REQUIRED TO LIMIT EQUIPMENT AND PIPING MOTION IN EXCESS OF 1/4 IN.
 - 4) ACCEPTABLE MANUFACTURERS:
 - a. MASON INDUSTRIES, INC.
 - b. VIBRATION ELIMINATOR CO.
 - c. KORFUND DYNAMICS CORP.
- B. CEILING-HUNG FANS AND EQUIPMENT:**
- 1) PROVIDE SPRING HANGER ROD ISOLATORS. STEEL COMPRESSION SPRING AND NEOPRENE SOUND PAD WITHIN A STEEL RETAINER BOX. SIMILAR TO MASON TYPE PCHS.
 - 2) 1 IN. MINIMUM STATIC DEFLECTION. 1/2 IN. MINIMUM RESERVE DEFLECTION. FACTORY-PRELOADED TO 75% OF RATED LOAD.
 - 3) PROVIDE SUPPLEMENTAL STEEL AS REQUIRED WHERE EQUIPMENT OR STRUCTURE CANNOT SUPPORT POINT LOADS.
- C. FLOOR MOUNTED EQUIPMENT HAVING INTERNAL ISOLATION:**
- 1) PROVIDE 5/16 IN. -THICK NEOPRENE ACOUSTICAL BASE PADS OF RIBBED OR WAFFLE CONSTRUCTION. SIMILAR TO MASON TYPE W.
 - 2) 50 PSI MAXIMUM LOADING. PROVIDE STEEL BEARING PLATE TO DISTRIBUTE LOAD WHERE REQUIRED.
- D. FLOOR-MOUNTED EQUIPMENT REQUIRING EXTERNAL VIBRATION ISOLATION:**
- 1) PROVIDE BUILT-IN RESILIENT VERTICAL LIMIT STOPS. PROVIDE TWO LAYERS OF 1/4 IN. NEOPRENE BASE PAD SEPARATED BY 1/16 IN. SHEET STEEL. TAPPED HOLES SHALL BE IN TOP PLATE FOR BOLTING TO EQUIPMENT. ISOLATORS SHALL BE CAPABLE OF SUPPORTING EQUIPMENT AT A FIXED ELEVATION DURING ISOLATION.
 - 2) 1 IN. MINIMUM STATIC DEFLECTION.
 - 3) CORROSION RESISTANT WHEN EXPOSED TO WEATHER.
- 15. HVAC EQUIPMENT SPECIFICATIONS - SEE MECHANICAL SCHEDULES FOR MORE INFORMATION:**
- A) WATER SOURCE HEAT PUMP (WSHP-1, WSHP-2, WSHP-3):**
- 1) GENERAL
 - a. EQUIPMENT SHALL BE COMPLETELY ASSEMBLED, PIPED, INTERNALLY WIRED, FULLY CHARGED WITH R410A AND TEST OPERATED AT THE FACTORY. FILTERS ARE FURNISHED FOR FIELD INSTALLATION. THERMOSTAT FIELD INTERFACE TERMINAL STRIP, AND ALL SAFETY CONTROLS ARE FURNISHED AND FACTORY INSTALLED.
 - b. THE SYSTEM WATER INLET AND OUTLET CONNECTIONS SHALL BE FEMALE NPT COMPOSED OF COPPER. THE EQUIPMENT SHALL CONTAIN ETL, CETL, AND AHRJ-ISO 13295-1 LISTINGS AND LABELS PRIOR TO LEAVING THE FACTORY. SERVICE AND CAUTION AREA LABELS SHALL ALSO BE PLACED ON THE UNIT IN THEIR APPROPRIATE LOCATIONS
 - 2) SOUND ATTENUATION PACKAGE
 - a. SOUND ATTENUATION WILL BE APPLIED AS A STANDARD FEATURE IN THE PRODUCT DESIGN. THE SOUND REDUCTION PACKAGE (1/2 THROUGH 5-TON EQUIPMENT) WILL INCLUDE VIBRATION ISOLATION TO THE COMPRESSOR AND WATER-TO-REFRIGERANT COIL, UNIT BASE STIFFENERS, INSULATED METAL COMPRESSOR ENCLOSURE, AND A SECOND STAGE OF VIBRATION ISOLATION TO THE COMPRESSOR AND WATER-TO-REFRIGERANT BASE PAN.
 - b. THE UNIT SHALL BE TESTED AND RATED IN ACCORDANCE WITH AHRI 260.
 - 3) COMPRESSOR
 - a. THE UNIT SHALL CONTAIN A HIGH EFFICIENCY ROTARY OR SCROLL COMPRESSOR. EXTERNAL VIBRATION ISOLATION SHALL BE PROVIDED BY RUBBER MOUNTING DEVICES LOCATED UNDERNEATH THE MOUNTING BASE OF THE COMPRESSOR. A SECOND ISOLATION OF THE REFRIGERATION ASSEMBLY SHALL BE SUPPORTED UNDER THE COMPRESSOR MOUNTING BASE. INTERNAL THERMAL OVERLOAD PROTECTION SHALL BE PROVIDED. PROTECTION AGAINST EXCESSIVE DISCHARGE PRESSURE SHALL BE PROVIDED BY MEANS OF A HIGH PRESSURE SWITCH. PROTECTION AGAINST A LOSS OF CHARGE SHALL BE PROVIDED BY A LOW PRESSURE SAFETY.
 - 4) ELECTRICAL
 - a. THE UNIT CONTROL BOX SHALL CONTAIN ALL NECESSARY DEVICES TO ALLOW HEATING AND COOLING OPERATION TO OCCUR FROM A REMOTE WALL THERMOSTAT. THESE DEVICES SHALL BE AS FOLLOWS:
 - 24 VAC ENERGY LIMITING CLASS II 50 VA (MINIMUM TRANSFORMER
 - 24 VAC BLOWER MOTOR RELAY
 - 24 VAC COMPRESSOR CONTACTOR FOR COMPRESSOR CONTROL
 - FIELD THERMOSTAT CONNECTIONS SHALL BE PROVIDED FOR EASE OF HOOK-UP TO A TERMINAL STRIP LOCATED IN THE UNIT'S CONTROL BOX
 - LOCKOUT RELAY WHICH CONTROLS CYCLING OF THE COMPRESSOR SHALL BE PROVIDED TO PROTECT THE COMPRESSOR DURING ADVERSE OPERATING CONDITIONS. THE DEVICE MAY BE RESET BY INTERRUPTING POWER TO THE 24 VAC CONTROL CIRCUIT. RESET MAY BE DONE EITHER AT A REMOTE THERMOSTAT OR THROUGH A MOMENTARY MAIN POWER INTERRUPTION.
- 5) DRAIN PAN
 - a. THE CONDENSATE PAN SHALL BE CONSTRUCTED OF CORROSION RESISTANT MATERIAL AND INSULATED TO PREVENT SWEATING. THE BOTTOM OF THE DRAIN PAN SHALL BE SLOPED ON TWO PLANES WHICH PITCHES THE CONDENSATE TO THE DRAIN CONNECTION. THIS POSITIVELY SLOPED DRAIN PAN COMPLIES WITH ASHRAE 92 FOR IAQ CONFORMITY. WHEN THE UNIT IS INSTALLED AND TRAPPED PER THE MANUFACTURER'S INSTALLATION MANUAL, AND LOCAL CITY SPECIFICATIONS, THE DRAIN PAN SHALL BE DESIGNED TO LEAVE PUDDLES NO MORE THAN 2-INCHES IN DIAMETER, NO MORE THAN 1/8-INCH DEEP, NO LONGER THAN 3-MINUTES FOLLOWING STEP 3 OF THE FOLLOWING TEST.
 - i) TEMPORARILY PLUG THE DRAIN PAN.
 - ii) FILL THE DRAIN PAN WITH 1/2-INCH OF WATER OR THE MAXIMUM ALLOWED BY THE DRAIN PAN DEPTH, WHICHEVER IS SMALLER.
 - iii) REMOVE THE TEMPORARY PLUG.
- 6) MOTOR/FAN
 - a. THE MOTOR HAS A PERMANENT SPLIT CAPACITOR WITH THERMAL OVERLOAD PROTECTION. OPTIONS OF STANDARD STATIC OR HIGH STATIC CAN BE SELECTED. THE MOTOR CONTAINS A QUICK DISCONNECT PLUG AND PERMANENTLY LUBRICATED BEARING. THE FANS ARE PLACED IN A DRAW-THROUGH CONFIGURATION. THEY ARE CONSTRUCTED OF CORROSION RESISTANT GALVANIZED MATERIAL. REMOVAL OF THE MOTOR AND FAN WHEEL CAN BE MADE WITH THE ASSISTANCE OF A FACTORY PROVIDED ORIFICE RING DEVICE. THIS DEVICE ATTACHES THE WHEEL AND MOTOR TO THE FAN HOUSING IN A SINGLE ASSEMBLY ELIMINATING THE NEED FOR ACCESS TO THE SET SCREW ON THE BACKSIDE OF THE FAN HUB.
- 7) THROWAWAY FILTER
 - a. A 1" THROWAWAY FIBERGLASS FILTER(S) SHALL BE PROVIDED WITH THE UNIT.
- 8) THERMOSTATIC EXPANSION VALVE
 - a. THE EQUIPMENT IS PROVIDED WITH A BI-DIRECTIONAL THERMAL EXPANSION VALVE. THIS DEVICE ALLOWS OPERATION OF THE EQUIPMENT IN THE RANGE OF 25 TO 110 DEGREES F ENTERING FLUID TEMPERATURES AND 49.4 TO 85.6 DEGREES F ENTERING AIR TEMPERATURES. THE EQUIPMENT OPERATES WITH ONE VARIABLE (ENTERING WATER TEMPERATURE, ENTERING AIR TEMPERATURE, CFM OR GPM) AT AN EXTREME CONDITION. ALL OTHER VARIABLES MUST BE WITHIN THE NOMINAL RANGE OF OPERATION.
- 9) APPROVED MANUFACTURERS**
- a. CARRIER (BASIS OF DESIGN).**
- B) DRAIN PAN CONSTRUCTION**
- 1) PROVIDE A SINGLE WALL PRIMARY DRAIN PAN CONSTRUCTED ENTIRELY OF HEAVY GAUGE STAINLESS STEEL FOR SUPERIOR CORROSION RESISTANCE. STAINLESS STEEL PANS SHALL BE EXTENDED UNDER THE ENTIRE UNIT. DRAIN PANS SHALL BE OF ONE-PIECE CONSTRUCTION AND BE POSITIVELY SLOPED FOR CONDENSATE REMOVAL.
 - 2) DRAIN PANS SHALL BE FIELD REVERSIBLE FOR RIGHT OR LEFT HAND CONNECTIONS.
- C. CENTRIFUGAL INLINE DIRECT DRIVE FANS - (GX-1, QAF-1 & GX-1)**
- 1) DUCT MOUNTED SUPPLY, EXHAUST OR RETURN FANS SHALL BE OF CENTRIFUGAL, DIRECT DRIVEN IN-LINE TYPE.
 - 2) THE FAN HOUSING SHALL BE OF THE SQUARE DESIGN, CONSTRUCTED OF HEAVY GAUGE GALVANIZED STEEL AND SHALL INCLUDE SQUARE DUCT MOUNTING COLLARS.
 - 3) FAN CONSTRUCTION SHALL INCLUDE TWO REMOVABLE ACCESS PANELS LOCATED PERPENDICULAR TO THE MOTOR MOUNTING PANEL. THE ACCESS PANELS MUST BE SUFFICIENT SIZE TO PERMIT EASY ACCESS TO ALL INTERIOR COMPONENTS.
 - 4) THE FAN WHEEL SHALL BE CENTRIFUGAL BACKWARD INCLINED, CONSTRUCTED OF ALUMINUM AND SHALL INCLUDE A WHEEL CONE CAREFULLY MATCHED TO THE INLET CONE FOR PRECISE RUNNING TOLERANCES. WHEELS SHALL BE STATICALLY AND DYNAMICALLY BALANCED.
 - 5) MOTORS SHALL BE PERMANENTLY LUBRICATED AND CAREFULLY MATCHED TO THE FAN LOADS. MOTORS SHALL BE READILY ACCESSIBLE FOR MAINTENANCE.
 - 6) A NEMA 1 DISCONNECT SWITCH SHALL BE PROVIDED AS STANDARD, EXCEPT WITH EXPLOSION RESISTANT MOTORS, WHERE DISCONNECTS ARE OPTIONAL. FACTORY WIRING SHALL BE PROVIDED FROM MOTOR TO THE HANDY BOX.
 - 7) ALL FANS SHALL BEAR THE AMCA CERTIFIED RATINGS SEAL FOR BOTH SOUND AND AIR PERFORMANCE.
 - 8) EACH FAN SHALL BEAR A PERMANENTLY AFFIXED MANUFACTURER'S NAMEPLATE CONTAINING THE MODEL NUMBER AND INDIVIDUAL SERIAL NUMBER FOR FUTURE IDENTIFICATION.
 - 9) ACCEPTABLE MANUFACTURERS:
 - a. CAPTVEAIRE (BASIS OF DESIGN).
 - b. LOREN COOK.
 - c. APPROVED EQUAL.
- 16. AUTOMATIC CONTROLS - GENERAL REQUIREMENTS**
- A. FURNISH AND INSTALL A COMPLETE ELECTRIC OR ELECTRONIC CONTROL SYSTEM TO PROVIDE TEMPERATURE CONTROL AS SPECIFIED UNDER DESCRIPTION OF OPERATION.**
- B. WORK SHALL INCLUDE ALL WIRING, CONTROL EQUIPMENT, AND ACCESSORIES NECESSARY TO MAKE THIS SYSTEM COMPLETE. ALL WIRING SHALL BE 24 VOLT. ALL OUTDOOR CONTROL WIRING SHALL BE INSTALLED WITHIN ELECTRICAL CONDUIT. COORDINATE WITH MANUFACTURER FOR INTERCONNECTING CONTROLS INCLUDED IN EQUIPMENT. ALL CONTROL WORK SHALL BE INSTALLED BY HVAC CONTRACTOR.**
- C. ACCEPTABLE MANUFACTURERS:**
- 1) JOHNSON SERVICE CO.
 - 2) HONEYWELL, INC.
- D. OPERATION OF TYPICAL CONTROL SAFETY DEVICES.**
- 1) HOA SUPPLY FAN SWITCHES: SAFETY DEVICES SHALL BE INTERLOCKED WITH "HAND" AND "AUTOMATIC" POSITIONS IN SERIES WITH MOTOR CONTROLLER HOLDING COIL CIRCUIT. INTERLOCKING WITH OTHER FANS AND EQUIPMENT OF SYSTEM SHALL BE THROUGH "AUTOMATIC" POSITION ONLY. "HAND" POSITION SHALL BE FOR MAINTENANCE ONLY.
- E. SAFETY DEVICES FOR ALL SYSTEMS, EXCEPT AS OTHERWISE NOTED BELOW:**
- 1) ONE FREEZE PROTECTION THERMOSTAT PER COIL SECTION, WIRED TO STOP SUPPLY FAN IN THE EVENT OF LOW ENTERING AIR TEMPERATURE. THERMOSTAT SHALL BE AUTOMATIC RESET TYPE.
 - 2) FOR SYSTEMS OVER 2,000 CFM, A DUCT MOUNTED SMOKE DETECTOR WITH SAMPLING PROBE LOCATED IN THE SUPPLY AND RETURN DUCT/PLENUM SIMILAR TO GE MODEL SIGA-SO DUCT SHALL STOP THE SUPPLY FAN AND ASSOCIATED INTERLOCKED EQUIPMENT SHOULD PRODUCTS OF COMBUSTION BE SENSED.
 - 3) LOW STATIC PRESSURE LIMIT SWITCHES WITH MANUAL RESET SHALL STOP ASSOCIATED SUPPLY FANS WHEN STATIC PRESSURE AT SUPPLY FOR INLET SECTIONS FALLS TO ITS SETTING.
 - 4) HVAC PANEL(S) SHALL BE INCLUDED WITH THE FOLLOWING ALARM FEATURES:
 - (i) LOSS OF AIR FLOW ALARM
 - (ii) DRAIN PAN ALARM INDICATING A POSSIBLE OVERFLOW CONDITION
 - 5) FILTER ALARM INDICATING FILTERS ARE DIRTY AND NEEDS TO BE CHANGED
 - 6) COMPRESSOR HI/LO PRESSURE ALARMS: SHUT THE APPROPRIATE COMPRESSOR AND PREVENT COMPRESSOR DAMAGE FROM EXTREME PRESSURES.
 - 7) HEATER HI-LIMIT ALARM: SHUTS OFF THE HEATER WHEN THE TEMPERATURE RISES WITHIN THE UNIT DUE TO FAN FAILURE (I.E. NO AIRFLOW)
 - 8) ALL ALARMS INCLUDED ON THE MECHANICAL DRAWINGS AND SEQUENCE OF OPERATIONS THAT ARE NOT INCLUDED IN THIS SECTION.
 - 9) CONTRACTOR SHALL PROVIDE ADDITIONAL ATC WIRING AS REQUIRED FOR ALL STANDARD SAFETY FEATURE PROVIDED BY THE MANUFACTURER OF ALL SPECIFIED HVAC EQUIPMENT.



sweetgreen

3101 W. EXPOSITION BLVD.
LOS ANGELES, CALIFORNIA 90018

THESE DRAWINGS & SPECIFICATIONS ARE CONFIDENTIAL AND SHALL REMAIN THE SOLE PROPERTY OF SWEETGREEN CORPORATION. THEY SHALL NOT BE REPRODUCED (IN WHOLE OR IN PART), SHARED WITH THIRD PARTIES OR USED IN ANY MANNER ON OTHER PROJECTS OR EXTENSIONS TO THIS PROJECT WITHOUT THE PRIOR WRITTEN CONSENT OF SWEETGREEN CORPORATION. THESE DRAWINGS & SPECIFICATIONS ARE INTENDED TO EXPRESS DESIGN INTENT FOR A PROTOTYPICAL SWEETGREEN STORE WHICH IS SUBJECT TO CHANGE AT ANY TIME AND MAY NOT REFLECT ACTUAL SITE CONDITIONS. NEITHER PARTY SHALL HAVE ANY OBLIGATION OR LIABILITY TO THE OTHER EXCEPT AS STATED ABOVE UNTIL A WRITTEN AGREEMENT IS FULLY EXECUTED.

ARCHITECT OF RECORD:
O'NEIL LANGAN ARCHITECTS
15 WEST 37TH STREET
15TH FLOOR
NEW YORK, NY 10018
PHONE: 212-279-2670
FAX: 212-279-2671

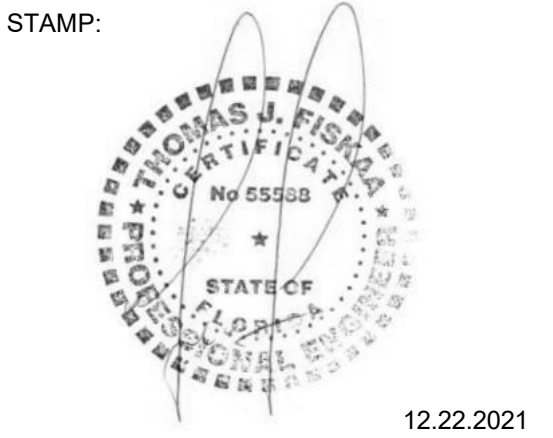

PROJECT INFORMATION:
TAMPA HEIGHTS
PROJECT INFORMATION:
**301 West Palm Avenue
Tampa FL 33602**

DRAWN BY: Author
CHECKED BY: Checker
PROJECT MANAGER: RC
SG DESIGN MANAGER: JM
SG CONSTR. MANAGER: JD
PROJECT NO: 221186
TEMPLATE VERSION: 06.01.2020

REV.	DATE	DESCRIPTION
	11.09.2021	SG REVIEW
	11.23.2021	LL REVIEW
	12.22.2021	PERMIT SET
2	04.04.2022	REVISION 2
3	05.26.2022	IFC
4	06.21.2022	FIELD REV 01

H.V.A.C. SPECIFICATIONS SHEET 2 OF 3

M-102

17. SEQUENCE OF OPERATIONS.

- A) WATER SOURCE HEAT PUMPS (WSHP-1, WSHP-2, WSHP-3):
- 1) FAN MODE: DURING STORE OPERATING HOURS EVAPORATOR SUPPLY FAN SHALL BE ENERGIZED TO MAINTAIN MINIMUM REQUIRE VENTILATION RATES. MINIMUM OUTDOOR AIR MOTORIZED DAMPER SHALL OPEN. UNIT COMPRESSORS SHALL REMAIN DE-ENERGIZED.
 - 2) COOLING: COOLING SHALL BE ACTIVATED VIA PROGRAMMABLE THERMOSTAT WITH ASSOCIATED TEMPERATURE SENSOR. WHEN SPACE TEMPERATURE EXCEEDS PRESET TEMPERATURE (ADJUSTABLE), CONDENSER WATER VALVES SHALL OPEN, COMPRESSOR SHALL BE ENERGIZED, AND THE EVAPORATOR FAN SHALL BE ENERGIZED LAST. COMPRESSOR SHALL CYCLE TO MAINTAIN SPACE TEMPERATURE. MINIMUM OUTDOOR AIR DAMPER AND RETURN AIR DAMPER SHALL MODULATE OPEN.

WHEN THE BASE BUILDING COOLING TOWER ENTERS FREE COOLING MODE, THE COMPRESSORS SHALL DE-ENERGIZE AND THE VALVES SHALL DIVERT CONDENSER WATER TO PASS THROUGH THE WATERSIDE ECONOMIZER COIL OF THE UNITS. THE FAN SHALL REMAIN ON.
 - 3) HEATING: HEATING SHALL BE ACTIVATED VIA PROGRAMMABLE THERMOSTAT WITH ASSOCIATED TEMPERATURE SENSOR. WHEN SPACE TEMPERATURE FALLS BELOW PRESET TEMPERATURE (ADJUSTABLE), CONDENSER WATER VALVES SHALL OPEN, COMPRESSOR SHALL BE ENERGIZED, AND THE EVAPORATOR FAN SHALL BE ENERGIZED LAST. COMPRESSOR SHALL CYCLE TO MAINTAIN SPACE TEMPERATURE. MINIMUM OUTDOOR AIR DAMPER AND RETURN AIR DAMPER SHALL MODULATE OPEN.
 - 4) AUXILIARY BACKUP HEAT: WHEN HEAT PUMP OPERATION IS NOT AVAILABLE, ELECTRIC DUCT HEATER SHALL ENERGIZE TO PROVIDE FULL HEATING.
- B) AIR CURTAIN (AD-1):
- 1) AIR CURTAIN SHALL BE CONTROLLED VIA ASSOCIATED THERMOSTAT AND ASSOCIATED REMOTE TEMPERATURE SENSOR. WHEN DOOR OPENS AIR CURTAIN AND HEATING ELEMENT SHALL ENERGIZE. SUPPLY FAN SHALL REMAIN ON UNTIL THE DOOR CLOSES.
- C) GENERAL KITCHEN EXHAUST FAN (GK-1):
- 1) EXHAUST FAN SHALL BE CONNECTED TO LUTRON SYSTEM.
- D) OUTSIDE AIR FAN (OAF-1):
- 1) FAN SHALL BE CONNECTED TO LUTRON SYSTEM.
- E) LEAK DETECTORS:
- 1) LEAK DETECTOR SHALL GENERATE A CONTROL SIGNAL WHENEVER WATER IS DETECTED. CONTROL SIGNAL SHALL NOTIFY TENANT OF THE ALARM CONDITION. A REMOTE MOUNTED RED LED ALARM LIGHT SHALL PROVIDE A VISUAL ALARM. LEAK DETECTOR SHALL HAVE AUDIBLE ALARM THAT WILL SOUND IF WATER IS DETECTED. UNIT SHALL AUTOMATICALLY DE-ENERGIZE. CONDENSER WATER FAST ACTING CONTROL VALVES SHALL CLOSE.
 - 2) ALL LEAK DETECTORS TO BE HARDWIRED TO EQUIPMENT BEING SERVED WITH REMOTE CONTACTS, OUTPUT TO TENANT REPRESENTATIVE TO BE BY AUTO DIALER OR EQUIVALENT.
- F) TOILET EXHAUST FAN (TX-1):
- 1) FAN SHALL BE CONNECTED TO LUTRON SYSTEM.
- G) PUMPS SHALL RUN CONTINUOUSLY WHENEVER COOLING IS REQUESTED FROM THE SYSTEM IT IS SERVING OR WHEN SYSTEM IS ENABLED BY THE OPERATOR. SPEED OF THE PUMPS SHALL VARY TO MAINTAIN THE LOWEST DIFFERENTIAL PRESSURE SETPOINT ACROSS ANY OF THE APPLICABLE DIFFERENTIAL PRESSURE SENSORS.



sweetgreen

3101 W. EXPOSITION BLVD.
LOS ANGELES, CALIFORNIA 90018

THESE DRAWINGS & SPECIFICATIONS ARE CONFIDENTIAL AND SHALL REMAIN THE SOLE PROPERTY OF SWEETGREEN CORPORATION. THEY SHALL NOT BE REPRODUCED (IN WHOLE OR IN PART), SHARED WITH THIRD PARTIES OR USED IN ANY MANNER ON OTHER PROJECTS OR EXTENSIONS TO THIS PROJECT WITHOUT THE PRIOR WRITTEN CONSENT OF SWEETGREEN CORPORATION. THESE DRAWINGS & SPECIFICATIONS ARE INTENDED TO EXPRESS DESIGN INTENT FOR A PROTOTYPICAL SWEETGREEN STORE WHICH IS SUBJECT TO CHANGE AT ANY TIME AND MAY NOT REFLECT ACTUAL SITE CONDITIONS. NEITHER PARTY SHALL HAVE ANY OBLIGATION OR LIABILITY TO THE OTHER (EXCEPT AS STATED ABOVE) UNTIL A WRITTEN AGREEMENT IS FULLY EXECUTED.

ARCHITECT OF RECORD:

O'NEIL LANGAN
ARCHITECTS

15 WEST 37TH STREET
15TH FLOOR
NEW YORK, NY 10018
PHONE: 212-279-2670
FAX: 212-279-2671

STAMP:

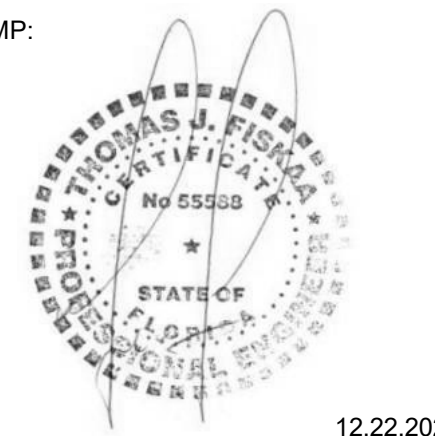

12.22.2021

PROJECT INFORMATION:
TAMPA HEIGHTS

PROJECT INFORMATION:
**301 West Palm Avenue
Tampa FL 33602**

DRAWN BY: Author
CHECKED BY: Checker
PROJECT MANAGER: RC
SG DESIGN MANAGER: JM
SG CONSTR. MANAGER: JD
PROJECT NO: 221186
TEMPLATE VERSION: 06.01.2020

REV.	DATE	DESCRIPTION
	11.09.2021	SG REVIEW
	11.23.2021	LL REVIEW
	12.22.2021	PERMIT SET
2	04.04.2022	REVISION 2
3	05.26.2022	IFC
4	06.21.2022	FIELD REV 01

H.V.A.C.
SPECIFICATIONS
SHEET 3 OF 3

M-103

COMcheck Software Version COMcheckWeb
Mechanical Compliance Certificate

Project Information
 Energy Code: 2020 Florida Building Code, Energy Conservation
 Project Title: 21.090 Sweetgreen-tempa height
 Location: Tampa, Florida
 Climate Zone: 2a
 Project Type: Alteration

Mechanical Systems List
Quantity System Type & Description

- 1 WSHF-1, WSHF-2 (Single Zone):
 Water Source Heat Pump
 Heating Mode: Capacity = 47 kBtu/h,
 Proposed Efficiency = 4.50 COP, Required Efficiency = 4.30 COP
 Cooling Mode: Capacity = 38 kBtu/h,
 Proposed Efficiency = 13.70 EER, Required Efficiency: 13.00 EER
- 1 WSHF-3 (Single Zone):
 Water Source Heat Pump
 Heating Mode: Capacity = 63 kBtu/h,
 Proposed Efficiency = 4.70 COP, Required Efficiency = 4.30 COP
 Cooling Mode: Capacity = 49 kBtu/h,
 Proposed Efficiency = 14.00 EER, Required Efficiency: 13.00 EER
- 1 DWH
 Electric Storage Water Heater, Capacity: 119 gallons w/ Circulation Pump
 Proposed Efficiency: 0.14 SL %/h (if > 12 kW), Required Efficiency: 0.53 SL %/h (if > 12 kW)

Mechanical Compliance Statement
 Compliance Statement: The proposed mechanical alteration project represented in this document is consistent with the building plans, specifications, and other calculations submitted with this permit application. The proposed mechanical systems have been designed to meet the 2020 Florida Building Code, Energy Conservation requirements in COMcheck Version COMcheckWeb and to comply with any applicable mandatory requirements listed in the Inspection Checklist.

Name - Title Signature Date

Project Title: 21.090 Sweetgreen-tempa height Report date: 12/13/21
 Data filename: Page 1 of 9

Section # & Req ID	Mechanical Rough-In Inspection	Complies?	Comments/Assumptions
C402.2.6 [ME41]	Thermally ineffective panel surfaces of sensible heating panels have insulation >= R-5.	<input type="checkbox"/> Complies <input type="checkbox"/> Does Not <input type="checkbox"/> Not Observable <input type="checkbox"/> Not Applicable	Exception: Requirement does not apply.
C403.2.12.1 [ME65]	HVAC fan systems at design conditions do not exceed allowable fan system motor nameplate hp or fan system blp.	<input type="checkbox"/> Complies <input type="checkbox"/> Does Not <input type="checkbox"/> Not Observable <input type="checkbox"/> Not Applicable	Requirement will be met. See the Mechanical Systems list for values.
C403.2.12.1 [ME65]	HVAC fan systems at design conditions do not exceed allowable fan system motor nameplate hp or fan system blp.	<input type="checkbox"/> Complies <input type="checkbox"/> Does Not <input type="checkbox"/> Not Observable <input type="checkbox"/> Not Applicable	Requirement will be met. See the Mechanical Systems list for values.
C403.2.12 [ME117]	Fans have energy index (FEI) >= 1.00 in accordance with AMCA 208. Fans for VAV systems shall have an FEI >= 0.95.	<input type="checkbox"/> Complies <input type="checkbox"/> Does Not <input type="checkbox"/> Not Observable <input type="checkbox"/> Not Applicable	Requirement will be met.
C403.2.12 [ME117]	Fans have energy index (FEI) >= 1.00 in accordance with AMCA 208. Fans for VAV systems shall have an FEI >= 0.95.	<input type="checkbox"/> Complies <input type="checkbox"/> Does Not <input type="checkbox"/> Not Observable <input type="checkbox"/> Not Applicable	Requirement will be met.
C403.2.3 [ME55]	HVAC equipment efficiency verified.	<input type="checkbox"/> Complies <input type="checkbox"/> Does Not <input type="checkbox"/> Not Observable <input type="checkbox"/> Not Applicable	Requirement will be met. See the Mechanical Systems list for values.
C403.2.6 [ME59]	Natural or mechanical ventilation is provided in accordance with Florida Building Code Chapter 4. Mechanical ventilation has capability to reduce outdoor air supply to minimum per Florida Building Code Chapter 4.	<input type="checkbox"/> Complies <input type="checkbox"/> Does Not <input type="checkbox"/> Not Observable <input type="checkbox"/> Not Applicable	Requirement will be met.
C403.2.6 [ME59]	Demand control ventilation provided for spaces >500 ft ² and >25 people/1000 ft ² occupant density and served by systems with air side economizer, auto modulating outside air damper control, or design airflow >= 3,000 cfm.	<input type="checkbox"/> Complies <input type="checkbox"/> Does Not <input type="checkbox"/> Not Observable <input type="checkbox"/> Not Applicable	Exception: Requirement does not apply.
C403.2.6 [ME115]	Enclosed parking garage ventilation has automatic contaminant detection and capacity to stage or modulate fans to 50% or less of design capacity.	<input type="checkbox"/> Complies <input type="checkbox"/> Does Not <input type="checkbox"/> Not Observable <input type="checkbox"/> Not Applicable	Exception: Requirement does not apply.
C403.2.4 [ME141]	HVAC systems serving guestrooms in Group R-1 buildings with > 50 guestrooms. Each guestroom is provided with controls that automatically manage temperature setpoint and ventilation (see sections C403.2.4.8.1 and C403.2.4.8.2).	<input type="checkbox"/> Complies <input type="checkbox"/> Does Not <input type="checkbox"/> Not Observable <input type="checkbox"/> Not Applicable	Exception: Requirement does not apply.
C403.2.7 [ME57]	Exhaust air energy recovery on systems meeting Table C403.2.7(1) and C403.2.7(2).	<input type="checkbox"/> Complies <input type="checkbox"/> Does Not <input type="checkbox"/> Not Observable <input type="checkbox"/> Not Applicable	Exception: Requirement does not apply.
C403.2.8 [ME116]	Kitchen exhaust systems comply with replacement air and conditioned supply air limitations, and satisfy hood rating requirements and maximum exhaust rate criteria.	<input type="checkbox"/> Complies <input type="checkbox"/> Does Not <input type="checkbox"/> Not Observable <input type="checkbox"/> Not Applicable	Exception: Requirement does not apply.

Project Title: 21.090 Sweetgreen-tempa height Report date: 12/13/21
 Data filename: Page 5 of 9

COMcheck Software Version COMcheckWeb
Inspection Checklist

Energy Code: 2020 Florida Building Code, Energy Conservation
 Requirements: 100.0% were addressed directly in the COMcheck software
 Text in the "Comments/Assumptions" column is provided by the user in the COMcheck Requirements screen. For each exception is being claimed. Where compliance is itemized in a separate table, a reference to that table is provided.

Section # & Req ID	Plan Review	Complies?	Comments/Assumptions
C103.2 [PR2]	Plans, specifications, and/or calculations provide all information with which compliance can be determined for the mechanical systems and equipment and document where exceptions to the standard are claimed. Load calculations per acceptable engineering standards and handbooks.	<input type="checkbox"/> Complies <input type="checkbox"/> Does Not <input type="checkbox"/> Not Observable <input type="checkbox"/> Not Applicable	Requirement will be met.
C103.2 [PR3]	Plans, specifications, and/or calculations provide all information with which compliance can be determined for the service water heating systems and equipment and document where exceptions to the standard are claimed. Hot water system sized per manufacturer's sizing guide.	<input type="checkbox"/> Complies <input type="checkbox"/> Does Not <input type="checkbox"/> Not Observable <input type="checkbox"/> Not Applicable	Requirement will be met.

Additional Comments/Assumptions:

1 High Impact (Tier 1) 2 Medium Impact (Tier 2) 3 Low Impact (Tier 3)

Project Title: 21.090 Sweetgreen-tempa height Report date: 12/13/21
 Data filename: Page 2 of 9

Section # & Req ID	Mechanical Rough-In Inspection	Complies?	Comments/Assumptions
C403.2.9 [ME60]	HVAC ducts and plenums insulated in accordance with C403.2.9.1 and constructed in accordance with C403.2.9.2, verification may need to occur during Foundation Inspection.	<input type="checkbox"/> Complies <input type="checkbox"/> Does Not <input type="checkbox"/> Not Observable <input type="checkbox"/> Not Applicable	Requirement will be met.
C408.2.2 [ME53]	Air outlets and zone terminal devices have means for air balancing.	<input type="checkbox"/> Complies <input type="checkbox"/> Does Not <input type="checkbox"/> Not Observable <input type="checkbox"/> Not Applicable	Requirement will be met.
C403.5.1 [ME123]	Refrigerated display cases, walk-in coolers or walk-in freezers served by remote compressors and remote condensers not located in a condensing unit, have fan-powered condensers that comply with Sections C403.5.1 and refrigeration compressor systems that comply with C403.5.2.	<input type="checkbox"/> Complies <input type="checkbox"/> Does Not <input type="checkbox"/> Not Observable <input type="checkbox"/> Not Applicable	Exception: Requirement does not apply.

Additional Comments/Assumptions:

1 High Impact (Tier 1) 2 Medium Impact (Tier 2) 3 Low Impact (Tier 3)

Project Title: 21.090 Sweetgreen-tempa height Report date: 12/13/21
 Data filename: Page 6 of 9

Section # & Req ID	Footing / Foundation Inspection	Complies?	Comments/Assumptions
C403.2.4.5 [FO9]	Snow/melt system and freeze protection systems have sensors and controls configured to limit service for pavement temperature and outdoor temperature. Future connection to controls.	<input type="checkbox"/> Complies <input type="checkbox"/> Does Not <input type="checkbox"/> Not Observable <input type="checkbox"/> Not Applicable	Exception: Requirement does not apply.

Additional Comments/Assumptions:

1 High Impact (Tier 1) 2 Medium Impact (Tier 2) 3 Low Impact (Tier 3)

Project Title: 21.090 Sweetgreen-tempa height Report date: 12/13/21
 Data filename: Page 3 of 9

Section # & Req ID	Rough-In Electrical Inspection	Complies?	Comments/Assumptions
C405.6 [EL26]	Low-voltage dry-type distribution electric transformers meet the minimum efficiency requirements of Table C405.6.	<input type="checkbox"/> Complies <input type="checkbox"/> Does Not <input type="checkbox"/> Not Observable <input type="checkbox"/> Not Applicable	Requirement will be met.
C405.7 [EL27]	Electric motors meet the minimum efficiency requirements of Tables C405.7(1) through C405.7(4). Efficiency verified through certification under an approved certification program or the equipment efficiency ratings shall be provided by motor manufacturer (where certification programs do not exist).	<input type="checkbox"/> Complies <input type="checkbox"/> Does Not <input type="checkbox"/> Not Observable <input type="checkbox"/> Not Applicable	Requirement will be met.
C405.8.2 [EL28]	Escalators and moving walks comply with ASME A17.1/CSA B44 and have automatic controls configured to reduce speed to the minimum permitted speed in accordance with ASME A17.1/CSA B44 or applicable local code when not conveying passengers.	<input type="checkbox"/> Complies <input type="checkbox"/> Does Not <input type="checkbox"/> Not Observable <input type="checkbox"/> Not Applicable	Exception: Requirement does not apply.
C405.5.3 [EL29]	Total voltage drop across the combination of feeders and branch circuits <= 5%.	<input type="checkbox"/> Complies <input type="checkbox"/> Does Not <input type="checkbox"/> Not Observable <input type="checkbox"/> Not Applicable	Requirement will be met.

Additional Comments/Assumptions:

1 High Impact (Tier 1) 2 Medium Impact (Tier 2) 3 Low Impact (Tier 3)

Project Title: 21.090 Sweetgreen-tempa height Report date: 12/13/21
 Data filename: Page 7 of 9

Section # & Req ID	Plumbing Rough-In Inspection	Complies?	Comments/Assumptions
C404.6.1 [PL3]	Automatic time switches installed to automatically switch off the recirculating hot-water system or heater trace.	<input type="checkbox"/> Complies <input type="checkbox"/> Does Not <input type="checkbox"/> Not Observable <input type="checkbox"/> Not Applicable	Requirement will be met.
C404.6.3 [PL7]	Pumps that circulate water between a heater and storage tank have controls that limit operation from startup to <= 5 minutes after end of heating cycle.	<input type="checkbox"/> Complies <input type="checkbox"/> Does Not <input type="checkbox"/> Not Observable <input type="checkbox"/> Not Applicable	Requirement will be met.
C404.7 [PL8]	Demand recirculation water systems have controls that start the pump upon receiving a signal from the action of a user of a fixture or appliance and limits the temperature of the water entering the cold-water piping to 104°F.	<input type="checkbox"/> Complies <input type="checkbox"/> Does Not <input type="checkbox"/> Not Observable <input type="checkbox"/> Not Applicable	Requirement will be met.

Additional Comments/Assumptions:

1 High Impact (Tier 1) 2 Medium Impact (Tier 2) 3 Low Impact (Tier 3)

Project Title: 21.090 Sweetgreen-tempa height Report date: 12/13/21
 Data filename: Page 4 of 9

Section # & Req ID	Final Inspection	Complies?	Comments/Assumptions
C403.2.1 [F50]	HVAC systems and equipment design loads calculated in accordance with ANSI/ASHRAE/ACCA Standard 183 or by an approved equivalent computational procedure.	<input type="checkbox"/> Complies <input type="checkbox"/> Does Not <input type="checkbox"/> Not Observable <input type="checkbox"/> Not Applicable	Requirement will be met.
C403.2.2 [F12]	HVAC systems and equipment capacity does not exceed calculated loads.	<input type="checkbox"/> Complies <input type="checkbox"/> Does Not <input type="checkbox"/> Not Observable <input type="checkbox"/> Not Applicable	Requirement will be met.
C403.2.4 [F14]	Heating and cooling to each zone is controlled by a thermostat control. Minimum one humidity control device per installed humidification/dehumidification system.	<input type="checkbox"/> Complies <input type="checkbox"/> Does Not <input type="checkbox"/> Not Observable <input type="checkbox"/> Not Applicable	Requirement will be met.
C403.2.4.1 [F147]	Heating and cooling to each zone is controlled by a thermostat control. Minimum one humidity control device per installed humidification/dehumidification system.	<input type="checkbox"/> Complies <input type="checkbox"/> Does Not <input type="checkbox"/> Not Observable <input type="checkbox"/> Not Applicable	Requirement will be met.
C403.2.4.1.1 [F142]	Heat pump controls prevent supplemental electric resistance heat from coming on when not needed.	<input type="checkbox"/> Complies <input type="checkbox"/> Does Not <input type="checkbox"/> Not Observable <input type="checkbox"/> Not Applicable	Requirement will be met.
C403.2.4.1.1 [F142]	Heat pump controls prevent supplemental electric resistance heat from coming on when not needed.	<input type="checkbox"/> Complies <input type="checkbox"/> Does Not <input type="checkbox"/> Not Observable <input type="checkbox"/> Not Applicable	Requirement will be met.
C403.2.4.1.2 [F138]	Thermostatic controls have a 5°F deadband.	<input type="checkbox"/> Complies <input type="checkbox"/> Does Not <input type="checkbox"/> Not Observable <input type="checkbox"/> Not Applicable	Requirement will be met.
C403.2.4.1.3 [F140]	Temperature controls have setpoint overlap restrictions.	<input type="checkbox"/> Complies <input type="checkbox"/> Does Not <input type="checkbox"/> Not Observable <input type="checkbox"/> Not Applicable	Requirement will be met.
C403.2.4.1 [F139]	Each zone equipped with setback controls using automatic time clock or programmable control system.	<input type="checkbox"/> Complies <input type="checkbox"/> Does Not <input type="checkbox"/> Not Observable <input type="checkbox"/> Not Applicable	Requirement will be met.
C403.2.4.2.1 [F146]	Automatic Controls: Setback to 55°F (heat) and 65°F (cool), 7-day clock, 2-hour occupant override, 10-hour backup.	<input type="checkbox"/> Complies <input type="checkbox"/> Does Not <input type="checkbox"/> Not Observable <input type="checkbox"/> Not Applicable	Requirement will be met.
C404.3 [F111]	Heat traps installed on supply and discharge piping of non-circulating systems.	<input type="checkbox"/> Complies <input type="checkbox"/> Does Not <input type="checkbox"/> Not Observable <input type="checkbox"/> Not Applicable	Exception: Requirement does not apply.
C404.4 [F125]	All recirculation piping, first 8 feet of outlet or branch piping, inlet piping and piping that is externally heated shall be insulated in accordance with section details and Table C403.2.10.	<input type="checkbox"/> Complies <input type="checkbox"/> Does Not <input type="checkbox"/> Not Observable <input type="checkbox"/> Not Applicable	Requirement will be met.

1 High Impact (Tier 1) 2 Medium Impact (Tier 2) 3 Low Impact (Tier 3)

Project Title: 21.090 Sweetgreen-tempa height Report date: 12/13/21
 Data filename: Page 8 of 9



sweetgreen
 3101 W. EXPOSITION BLVD.
 LOS ANGELES, CALIFORNIA 90018

THESE DRAWINGS & SPECIFICATIONS ARE CONFIDENTIAL AND SHALL REMAIN THE SOLE PROPERTY OF SWEETGREEN CORPORATION. THEY SHALL NOT BE REPRODUCED (IN WHOLE OR IN PART), SHARED WITH THIRD PARTIES OR USED IN ANY MANNER ON OTHER PROJECTS OR EXTENSIONS TO THIS PROJECT WITHOUT THE PRIOR WRITTEN CONSENT OF SWEETGREEN CORPORATION. THESE DRAWINGS & SPECIFICATIONS ARE INTENDED TO EXPRESS DESIGN INTENT FOR A PROTOTYPICAL SWEETGREEN STORE (WHICH IS SUBJECT TO CHANGE AT ANY TIME) AND MAY NOT REFLECT ACTUAL SITE CONDITIONS. NEITHER PARTY SHALL HAVE ANY OBLIGATION OR LIABILITY TO THE OTHER (EXCEPT AS STATED ABOVE) UNTIL A WRITTEN AGREEMENT IS FULLY EXECUTED.

ARCHITECT OF RECORD:
O'NEIL LANGAN
 ARCHITECTS
 15 WEST 37TH STREET
 15TH FLOOR
 NEW YORK, NY 10018
 PHONE: 212-279-2670
 FAX: 212-279-2671

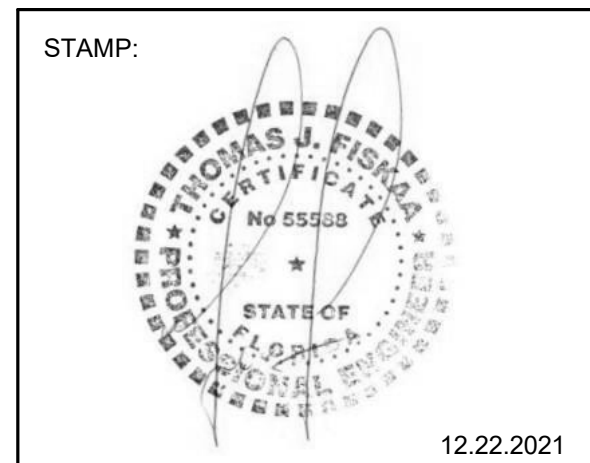

PROJECT INFORMATION:
TAMPA HEIGHTS
301 West Palm Avenue
Tampa FL 33602

DRAWN BY: CK
 CHECKED BY: JK
 PROJECT MANAGER: RC
 SG DESIGN MANAGER: JM
 SG CONSTR. MANAGER: JD
 PROJECT NO: 221186
 TEMPLATE VERSION: 06.01.2020

REV.	DATE	DESCRIPTION
1	11.09.2021	SG REVIEW
2	11.23.2021	LL REVIEW
3	12.22.2021	PERMIT SET
4	04.04.2022	REVISION 2
5	05.26.2022	IFC
6	06.21.2022	FIELD REV 01

H.V.A.C. ENERGY CODE COMPLIANCE FORMS

M-104

COMBI OVEN HOOD NOTES:

- FACTORY-BUILT COMMERCIAL COOKING RECIRCULATING SYSTEMS THAT ARE LISTED AND LABELED IN ACCORDANCE WITH UL 710B, AND INSTALLED IN ACCORDANCE WITH SECTION 304.1, SHALL NOT BE REQUIRED TO COMPLY WITH SECTIONS 507.1.5, 507.2.3, 507.2.5, 507.2.8, 507.3.1, 507.3.3, 507.4 AND 507.5. SPACES IN WHICH SUCH SYSTEMS ARE LOCATED SHALL BE CONSIDERED TO BE KITCHENS AND SHALL BE VENTILATED IN ACCORDANCE WITH TABLE 403.3.1.1. FOR THE PURPOSE OF DETERMINING THE FLOOR AREA REQUIRED TO BE VENTILATED, EACH INDIVIDUAL APPLIANCE SHALL BE CONSIDERED AS OCCUPYING NOT LESS THAN 100 SQUARE FEET (9.3 M²).

Technical specifications

Dimensions and weights	Combi oven - gas
Dimensions (W x H x D)	36" x 34" x 36" (914 x 863 x 914 mm)
Net weight	150 lbs (68 kg)
Shipping weight	165 lbs (75 kg)
Shipping dimensions (W x H x D)	40" x 38" x 40" (1016 x 965 x 1016 mm)
Net weight (with optional RATIONAL speed)	165 lbs (75 kg)
Shipping weight (with optional RATIONAL speed)	180 lbs (82 kg)
Net weight (with optional RATIONAL speed)	165 lbs (75 kg)
Shipping weight (with optional RATIONAL speed)	180 lbs (82 kg)

Electrical connection conditions

Voltage (V)	Combi oven - gas
120V	1500 VA
240V	1500 VA
380V	1500 VA
480V	1500 VA
575V	1500 VA

Water supply requirements

Water supply	Combi oven - gas
Water supply pressure	2.0 bar (29.0 psi)
Water supply temperature	100°F (38°C)
Water supply flow rate	1.0 gpm (3.8 lpm)

Water quality requirements

Water quality requirements: The UltraVent Plus gets rid of escaping steam with its condensation technology. It is also equipped with special filter technology which reduces lingering smells, which can build up while grilling and frying. No connection to the outside or extension of an existing exhaust system is necessary with this air recirculation hood. Installation is simple, and the hood can be retrofitted at any time.

Features

- Intelligent power control with automatic, continuously variable adjustment of the extraction power to the quantity of steam emitted
- Automatically boosts extraction rate when cooking cabinet door is opened
- Connects to both Combi cooking systems in a Combi Duo
- Eliminates lingering steam and vapors. These are extracted and condensed in the hood
- Special filter technology with a prefilter and HEPA H13 main filter to reduce smells
- Easy to install and retrofit
- Issues of service notifications on the display of the Combi Pro and Combi Classic
- Adjustment of maximum extraction power on the display
- Easy to clean stainless steel, dishwasher safe

Technical Specifications

- Connection: 120V - 1 NAC 50/60 Hz
- Connected load: 1700 VA
- Extraction capacity: 24000 l/h
- Operating noise level: min 50 dBA, max 60 dBA
- Width: 36.5 inches
- Height: 35.5 inches
- Depth: 36.5 inches
- Weight: 175 lbs

Material

- Flue-free stainless steel (CNS 1-4301)

Note

- To install an UltraVent, UltraVent Plus or exhaust hood on a SelfCookingCenter from 9000111 or CombiMaster Plus, a corresponding adapter kit is required
- The local standards and regulations for ventilation systems must be adhered to
- Only permitted for installation on electrical units

PLAN NOTES:

- CONTRACTOR SHALL VERIFY IN FIELD EXACT DUCT ROUTING LOCATION AND CONNECTIONS. CONTRACTOR SHALL COORDINATE WITH ALL TRADES BEFORE ANY WORK IS TO BE PERFORMED. REPORT ANY DISCREPANCIES TO BUILDING MANAGEMENT AND ENGINEER.
- CONTRACTOR SHALL INSTALL ALL NEW DUCT AS HIGH AS POSSIBLE TO THE CEILING. ALL NEW DUCTWORK SHALL BE PROPERLY SECURED AS PER MECHANICAL SPECIFICATIONS.
- PROVIDE VOLUME DAMPERS FOR ALL BRANCH DUCTS AND CONNECTIONS TO AIR OUTLETS. PROVIDE CABLE OPERATED, CONCEALED, OPPOSED BLADE DAMPERS FOR BRANCHES AND AIR OUTLETS LOCATED IN NON-ACCESSIBLE CEILINGS MAINTAIN AREA CEILING HEIGHTS.
- SHEET METAL DUCTWORK DIMENSIONS SHOWN ARE CLEAR INSIDE DIMENSIONS.
- COORDINATE LOCATIONS, ACCESS AND DETAILS OF VISIBLE DEVICES AND AIR OUTLETS WITH THE ARCHITECT PRIOR TO INSTALLATION.
- INTERNALLY LINED DUCTWORK IS REQUIRED FOR ACOUSTICAL PURPOSES. PROVIDE 1" ACOUSTICAL LINING 20 FEET UPSTREAM AND DOWNSTREAM OF FAN COIL UNITS AND FANS.
- PROVIDE CONNECTIONS TO AIR REGISTERS TO ALLOW FOR THE BRANCH VOLUME DAMPERS TO ROTATE WITHOUT OBSTRUCTION. SEE AIR OUTLET SCHEDULES FOR REGISTER NECK SIZES.
- COORDINATE EQUIPMENT & DUCTWORK HANGING WITH SEISMIC REQUIREMENTS FROM PANYNJ.
- CONTRACTOR TO FULLY WALK SITE PRIOR TO SUBMITTING FINAL BID.
- ALL TENANT HVAC SYSTEMS SHALL BE COMMISSIONED UPON COMPLETION OF CONSTRUCTION AND PRIOR TO OCCUPANCY AS PER THE REQUIREMENTS DEFINED IN THE TENANT TECHNICAL CRITERIA MANUAL.
- REFER TO TABLE CFM'S REQUIRED AT THE CONNECTION POINT FOR AIR BALANCING PURPOSES
- ANY USED USED HVAC EQUIPMENT, DUCTWORK, PIPING, WIRING, ETC. WITHIN OR SERVING THE DEMISED PREMISES MUST BE REMOVED.
- TENANT SHALL INSTALL AN INDICATOR PILOT LAMP 12" ABOVE THERMOSTAT FOR THE PURPOSE OF VERIFYING EXHAUST FAN OPERATION.

REFERENCE NOTES:

- PROVIDE AIR DOOR ABOVE ENTRANCE. REFER TO MECHANICAL SCHEDULES AND DETAILS FOR MORE INFORMATION.
- PROVIDE 1" DOOR UNDERCUT.
- PROVIDE WIRE MESH SCREEN IN RETURN DUCT
- PROVIDE CONDENSATE PUMP FOR WALK IN COOLER. ROUTE CONDENSATE PIPE TO NEAREST MOP SINK.
- PROVIDE CEILING HUNG WSHP UNIT WITH SPRING VIBRATION ISOLATORS AND SUPPLEMENTAL STEEL SUPPORT AS REQUIRED. PROVIDE UNIT WITH AUXILIARY STAINLESS STEEL DRAIN PAN, CONDENSATE PUMP, LEAK DETECTOR AND MIXING BOX. COORDINATE EXACT LOCATION WITH CLIENT AND ARCHITECT. COORDINATE STRUCTURAL SUPPORT WITH STRUCTURAL ENGINEER. PROVIDE UNIT WITH PROPER CLEARANCE FOR SERVICE AND MAINTENANCE. REFER TO SCHEDULES AND MANUFACTURER'S MANUAL FOR MORE INFORMATION.
- CONNECT OUTSIDE AIR DUCT TO MIXING BOX.
- THE STRUCTURE HAS BEEN CHECKED FOR LOADS IMPOSED. THE WEIGHTS OF THE PROPOSED UNITS ARE SHOWN ON DRAWING S-101 AND THE CORRESPONDING HANGING UNIT DETAILS ARE SHOWN ON S-500



sweetgreen
3101 W. EXPOSITION BLVD.
LOS ANGELES, CALIFORNIA 90018

THESE DRAWINGS & SPECIFICATIONS ARE CONFIDENTIAL AND SHALL REMAIN THE SOLE PROPERTY OF SWEETGREEN CORPORATION. THEY SHALL NOT BE REPRODUCED (IN WHOLE OR IN PART), SHARED WITH THIRD PARTIES OR USED IN ANY MANNER ON OTHER PROJECTS OR EXTENSIONS TO THIS PROJECT WITHOUT THE PRIOR WRITTEN CONSENT OF SWEETGREEN CORPORATION. THESE DRAWINGS & SPECIFICATIONS ARE INTENDED TO EXPRESS DESIGN INTENT FOR A PROTOTYPICAL SWEETGREEN STORE WHICH IS SUBJECT TO CHANGE AT ANY TIME AND MAY NOT REFLECT ACTUAL SITE CONDITIONS. NEITHER PARTY SHALL HAVE ANY OBLIGATION OR LIABILITY TO THE OTHER (EXCEPT AS STATED ABOVE) UNTIL A WRITTEN AGREEMENT IS FULLY EXECUTED.

ARCHITECT OF RECORD:
O'NEIL LANGAN ARCHITECTS
15 WEST 37TH STREET
15TH FLOOR
NEW YORK, NY 10018
PHONE: 212-279-2670
FAX: 212-279-2671

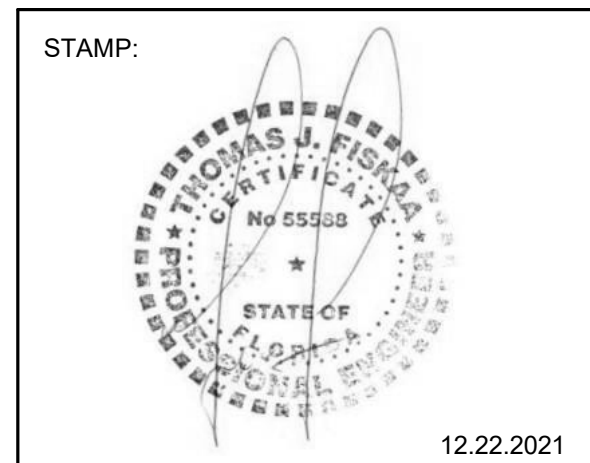

PROJECT INFORMATION:
TAMPA HEIGHTS
301 West Palm Avenue
Tampa FL 33602

DRAWN BY: XX
CHECKED BY: XX
PROJECT MANAGER: RC
SG DESIGN MANAGER: JM
SG CONSTR. MANAGER: JD
PROJECT NO: 221186
TEMPLATE VERSION: 06.01.2020

REV.	DATE	DESCRIPTION
	11.23.2021	LL REVIEW
	12.22.2021	PERMIT SET
1	02.10.2022	REVISION 1
2	04.04.2022	REVISION 2
3	05.26.2022	IFC
4	06.21.2022	FIELD REV 01

H.V.A.C. GROUND FLOOR PLANS

M-300

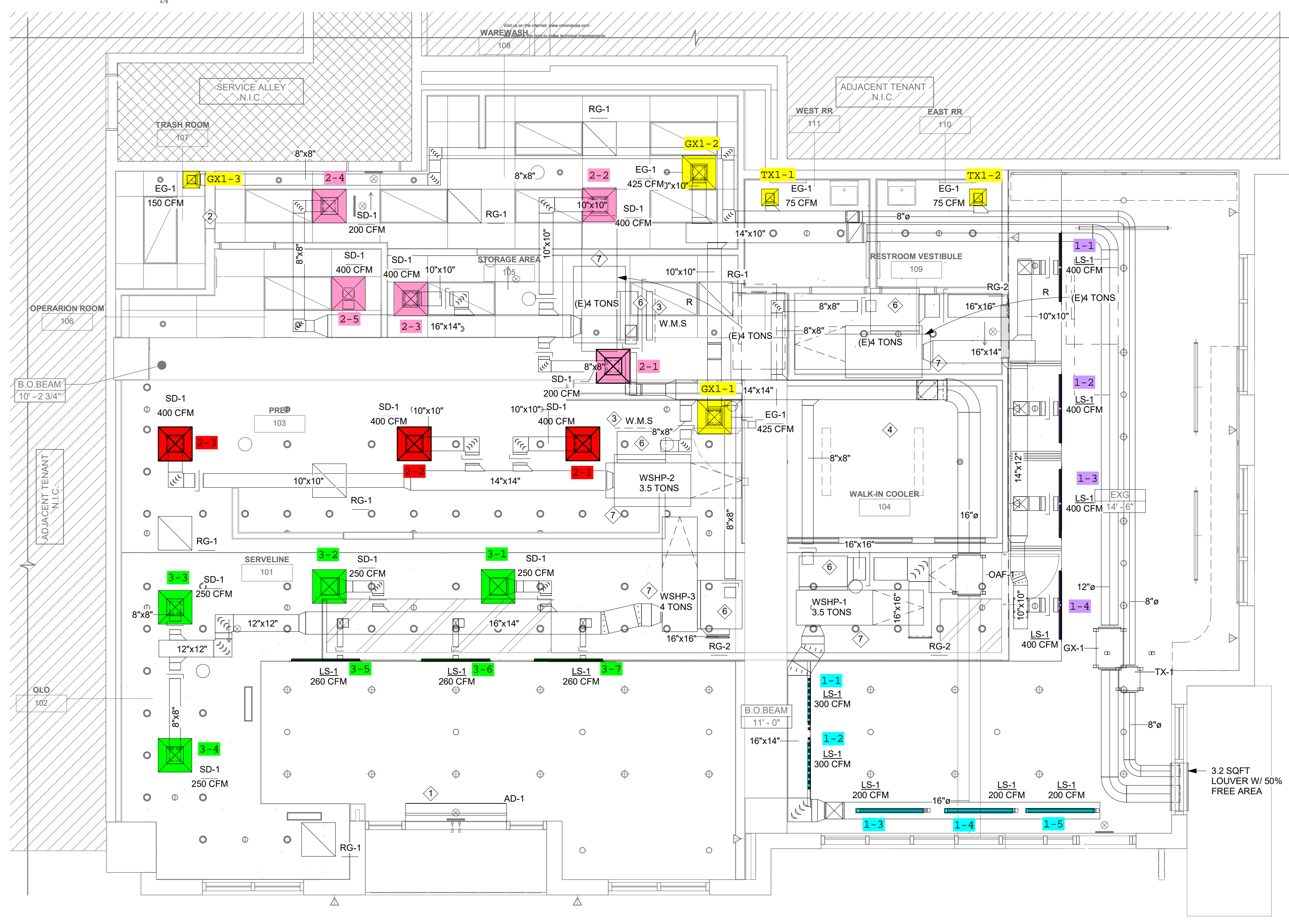

1 H.V.A.C. GROUND FLOOR PLANS
1/4" = 1'-0"

6/27/2022 9:54:53 AM



sweetgreen

3101 W. EXPOSITION BLVD.
LOS ANGELES, CALIFORNIA 90018

THESE DRAWINGS & SPECIFICATIONS ARE CONFIDENTIAL AND SHALL REMAIN THE SOLE PROPERTY OF SWEETGREEN CORPORATION. THEY SHALL NOT BE REPRODUCED (IN WHOLE OR IN PART), SHARED WITH THIRD PARTIES OR USED IN ANY MANNER ON OTHER PROJECTS OR EXTENSIONS TO THIS PROJECT WITHOUT THE PRIOR WRITTEN CONSENT OF SWEETGREEN CORPORATION. THESE DRAWINGS & SPECIFICATIONS ARE INTENDED TO EXPRESS DESIGN INTENT FOR A PROTOTYPICAL SWEETGREEN STORE WHICH IS SUBJECT TO CHANGE AT ANY TIME AND MAY NOT REFLECT ACTUAL SITE CONDITIONS. NEITHER PARTY SHALL HAVE ANY OBLIGATION NOR LIABILITY TO THE OTHER (EXCEPT AS STATED ABOVE) UNTIL A WRITTEN AGREEMENT IS FULLY EXECUTED.

ARCHITECT OF RECORD:

O'NEIL LANGAN
ARCHITECTS

15 WEST 37TH STREET
15TH FLOOR
NEW YORK, NY 10018
PHONE: 212-279-2670
FAX: 212-279-2671

STAMP:

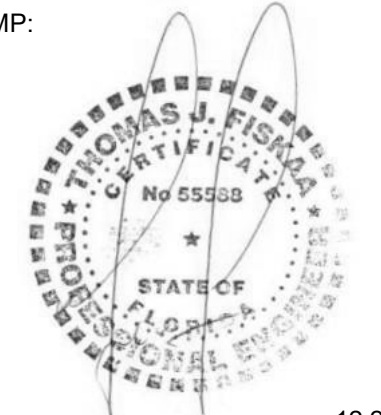

12.22.2021

PROJECT INFORMATION:
TAMPA HEIGHTS

PROJECT INFORMATION:
301 West Palm Avenue
Tampa FL 33602

DRAWN BY: XX
CHECKED BY: XX
PROJECT MANAGER: RC
SG DESIGN MANAGER: JM
SG CONSTR. MANAGER: JD
PROJECT NO: 221186
TEMPLATE VERSION: 06.01.2020

REV.	DATE	DESCRIPTION
	11.09.2021	SG REVIEW
	11.23.2021	LL REVIEW
	12.22.2021	PERMIT SET
2	04.04.2022	REVISION 2
3	05.26.2022	IFC
4	06.21.2022	FIELD REV 01

H.V.A.C. GROUND FLOOR PIPING PLANS

M-400

PLAN NOTES:

- CONTRACTOR SHALL VERIFY IN FIELD EXACT PIPE ROUTING LOCATIONS AND CONNECTIONS AND INSTALL ALL PIPING SHOWN ON THIS PLAN AS HIGH AS POSSIBLE TO THE STRUCTURE ABOVE. CONTRACTOR SHALL COORDINATE WITH ALL TRADES BEFORE ANY WORK IS TO BE PERFORMED. REPORT ANY DISCREPANCIES TO THE OWNER AND ENGINEER.
- PROVIDE FIRE RATED SEALANT AROUND PIPING PENETRATIONS THROUGH FIRE RATED WALLS. SEALANT TO BE FIRE RATED IN ACCORDANCE WITH THE WALL/PARTITION'S FIRE RATINGS.
- COORDINATE ALL HVAC EQUIPMENT WITH OTHER TRADES (I.E. PLUMBING, SPRINKLER, ELECTRICAL POWER AND LIGHTING, ARCHITECTURAL, ETC.) PROVIDE COORDINATED SHOP DRAWINGS INDICATING ALL OF THE MANUFACTURER'S RECOMMENDED CLEARANCES UNOBSTRUCTED FOR REVIEW PRIOR TO INSTALLATION.
- ALL PIPING SHOWN ON THIS PLAN IS DIAGRAMMATIC. MECHANICAL CONTRACTOR TO COORDINATE PIPING INSTALLATION WITH MANUFACTURER PRIOR TO COMMENCEMENT OF WORK.
- PROVIDE INSULATION ON ALL PIPING IN ACCORDANCE WITH INSULATION REQUIREMENTS IN MECHANICAL SPECIFICATIONS.
- ROUTE CONDENSATE PIPING TO MOP SINK IN BOH

REFERENCE NOTES:

- CONTRACTOR SHALL COORDINATE CONDENSER WATER PIPE SIZES, QUANTITIES AND ROUTING WITH UNIT MANUFACTURER.
- PROVIDE CEILING HUNG WSHF WITH STAINLESS STEEL DRIP PAN WITH LEAK DETECTION SYSTEM. PROVIDE CONDENSATE PUMP.
- PROVIDE WSHF-1 THROUGH WSHF-3 and (E) WSHF WITH 7-DAY PROGRAMMABLE THERMOSTAT.
- PROVIDE CONDENSATE PUMP FOR WALK IN COOLER. ROUTE CONDENSATE PIPE TO NEAREST MOP SINK.

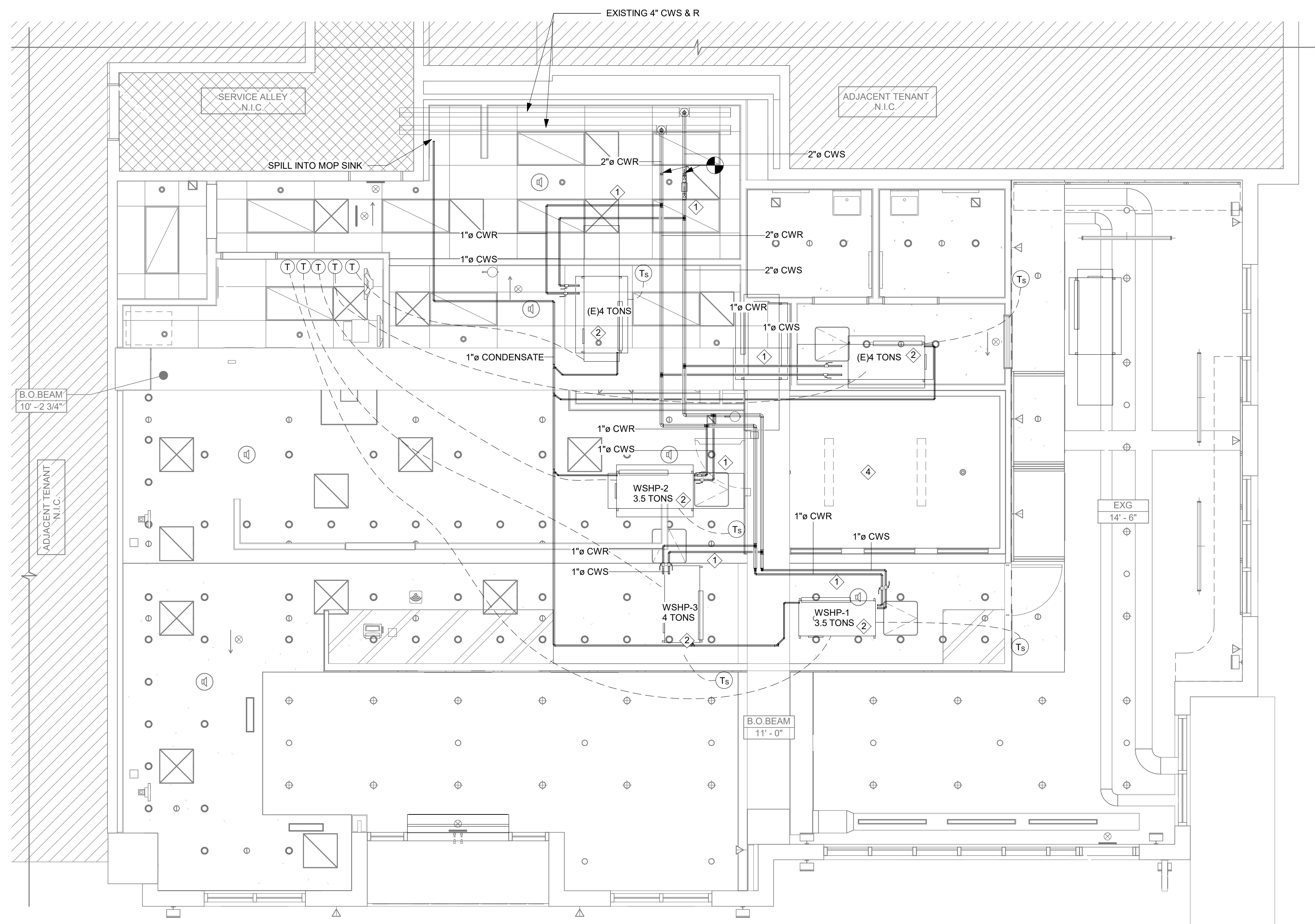

1 H.V.A.C. GROUND FLOOR PIPING PLANS
1/4" = 1'-0"



sweetgreen

3101 W. EXPOSITION BLVD. LOS ANGELES, CALIFORNIA 90018

THESE DRAWINGS & SPECIFICATIONS ARE CONFIDENTIAL AND SHALL REMAIN THE SOLE PROPERTY OF SWEETGREEN CORPORATION. THEY SHALL NOT BE REPRODUCED IN WHOLE OR IN PART, SHARED WITH THIRD PARTIES OR USED IN ANY MANNER ON OTHER PROJECTS OR EXTENSIONS TO THIS PROJECT WITHOUT THE PRIOR WRITTEN CONSENT OF SWEETGREEN CORPORATION.

ARCHITECT OF RECORD:

O'NEIL LANGAN ARCHITECTS

15 WEST 37TH STREET 15TH FLOOR NEW YORK, NY 10018 PHONE: 212-279-2670 FAX: 212-279-2671

STAMP:

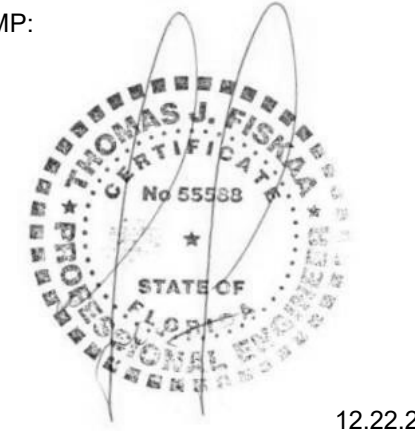

12.22.2021

PROJECT INFORMATION: TAMPA HEIGHTS 301 West Palm Avenue Tampa FL 33602

DRAWN BY: XX CHECKED BY: XX PROJECT MANAGER: RC SG DESIGN MANAGER: JM SG CONSTR. MANAGER: JD PROJECT NO: 221186 TEMPLATE VERSION: 06.01.2020

REVISIONS REV. DATE DESCRIPTION 11.09.2021 SG REVIEW 11.23.2021 LL REVIEW 12.22.2021 PERMIT SET 2 04.04.2022 REVISION 2 3 05.26.2022 IFC 4 06.21.2022 FIELD REV 01

H.V.A.C. SCHEDULES

M-600

PACKAGED WATER SOURCE HEAT PUMP UNIT SCHEDULE

Table with columns: DESIG., TONS, FAN DATA (TOTAL S.A. (CFM), ESP (IN. WG), OA, TOTAL (MBH), SENSIBLE (MBH), E.A.T. D.B. / W.B. (DEG. F), EWT / LWT (DEG. F), LAT D.B. / W.B. (DEG. F), GPM, FLUID PD (FT.H2O)), COOLING DATA (TOTAL (MBH), EWT (DEG. F), LAT D.B. / W.B. (DEG. F), GPM, FLUID PD (FT.H2O)), HEATING DATA (TOTAL (MBH), EWT (DEG. F), LAT D.B. / W.B. (DEG. F), GPM, FLUID PD (FT.H2O)), ELECTRICAL DATA (V/Hz, MCA, FLA, MFS), EER, COP, WEIGHT, REFIG. TYPE, MANUF., MODEL, REMARKS.

NOTES: 1. CONTRACTOR TO PROVIDE 1/4" THICK RUBBER ISOLATOR PAD. 2. ULTRA QUIET PACKAGE SHALL CONSIST OF HIGH TECHNOLOGY SOUND ATTENUATING MATERIAL THAT IS STRATEGICALLY APPLIED TO THE COMPRESSOR (ROTARY ONLY) AND INSIDE COMPRESSOR. 3. PROVIDE WITH WALL MOUNTED DIGITAL THERMOSTAT AND BUTTON-TYPE TEMPERATURE SENSOR. 4. COORDINATE ACCESS PANEL FINISHING AND TYPE WITH ARCHITECT. 5. PROVIDE WITH OVERSIZED BLOWER WITH HIGH STATIC MOTOR. 6. PROVIDE WITH AUTO FLOW REGULATOR. 7. PROVIDE WITH MOTORIZED SHUT OFF VALVE. 8. PROVIDE WITH MANUAL SHUT OFF VALVE TO ISOLATE UNIT DURING SERVICE. 9. PROVIDE WITH HOSE KIT. 10. PROVIDE WITH STAINLESS STEEL DRAIN PAN AND LEAK DETECTORS. LEAK DETECTORS SHALL SHUT-OFF THE UNIT IN. 11. CONTRACTOR TO PROVIDE WITH DISCONNECT SWITCH. 12. CONTRACTOR TO PROVIDE WITH VIBRATION ISOLATORS. 13. COORDINATE UNIT CONFIGURATION WITH MECHANICAL DRAWINGS. 14. UNIT TO BE RATED FOR 400 PSI WORKING PRESSURE AND 600 PSI TEST PRESSURE. 15. UNITS SHALL BE PROVIDED WITH BACNET CONTROLLER. 16. ALL AC UNITS TO HAVE LOW ENTERING WATER CONTROLS. 17. FILTER SHALL BE MERV 13.

OUTDOOR AIR CALCULATIONS

Table with columns: ROOM DESIGNATION, CLASSIFICATION, AREA (SF), NR. OF FIXTURES, DEFAULT OCCUPANCY (PPL/1000 SF), OCCUPANCY BY AREA, AIR RATE (CFM/SF, CFM/PERSON, CFM/FIXTURE), VENTILATION REQUIRED (OCCUPANCY, AREA, FIXTURES), VENTILATION PROVIDED (CFM).

NOTES: BASED ON TABLE 403.3 - MINIMUM VENTILATION RATES OF FL MECHANICAL CODE

AIR DOOR SCHEDULE

Table with columns: DESIG., LOCATION, FAN (AIR VOLUME CFM, MAX FPM @ NOZZLE), HP, ΔT (°F), ELECTRICAL MOTORS & UNIT (V/PH/Hz, MCA, MOP), WEIGHT (LBS), MANUF. MODEL NO., REMARKS.

NOTES: 1. PROVIDE WITH DOOR SWITCH. 2. PROVIDE WITH HANGING BRACKETS.

AIR OUTLET SCHEDULE

Table with columns: DESIG., TYPE, CFM RANGE, MAX NC, NECK SIZE, FACE SIZE OR LENGTH X WIDTH, FLOW PATTERN, MANUF., MODEL No., REMARKS.

NOTES: 1. COORDINATE AIR OUTLET BORDER TYPES, FRAMING, AND FINISHES WITH THE ARCHITECT. 2. PROVIDE ALL AIR OUTLETS WITH VOLUME DAMPERS. 3. PROVIDE CABLE OPERATED DAMPERS YOUNG REGULATOR MODEL 800AW FOR AIR OUTLETS IN SHEETROCK OR INACCESSIBLE CEILINGS. 4. PROVIDE EXHAUST GRILLES WITH BACKDRAFT DAMPERS

FAN SCHEDULE

Table with columns: DESIG., C.F.M., S.P. (IN. WG), FAN SPEED (RPM), MOTOR POWER (HP), ELECTRICAL (V/Hz, FLA), SONES, WEIGHT (LBS.), MANUF., MODEL No., REMARKS.

NOTES: 1. PROVIDE WITH DISCONNECT SWITCH. 2. COORDINATE INSTALLATION WITH FIELD CONDITIONS. 3. PROVIDE WITH VIBRATION ISOLATORS. 4. PROVIDE WITH BACKDRAFT DAMPER. 5. TENANT SHALL INSTALL AN INDICATOR PILOT LAMP 12" ABOVE THERMOSTAT FOR THE PURPOSE OF VERIFYING EXHAUST FAN OPERATION.

Air System Sizing Summary for BLOCK LOAD

Summary table for Air System Sizing for BLOCK LOAD, including Air System Information, Sizing Calculation Information, Central Cooling Coil Sizing Data, Central Heating Coil Sizing Data, Supply Fan Sizing Data, and Outdoor Ventilation Air Data.

Air System Design Load Summary for BLOCK LOAD

Summary table for Air System Design Load for BLOCK LOAD, including Design Cooling and Design Heating data, and Zone Loads.

6/27/2022 9:54:56 AM

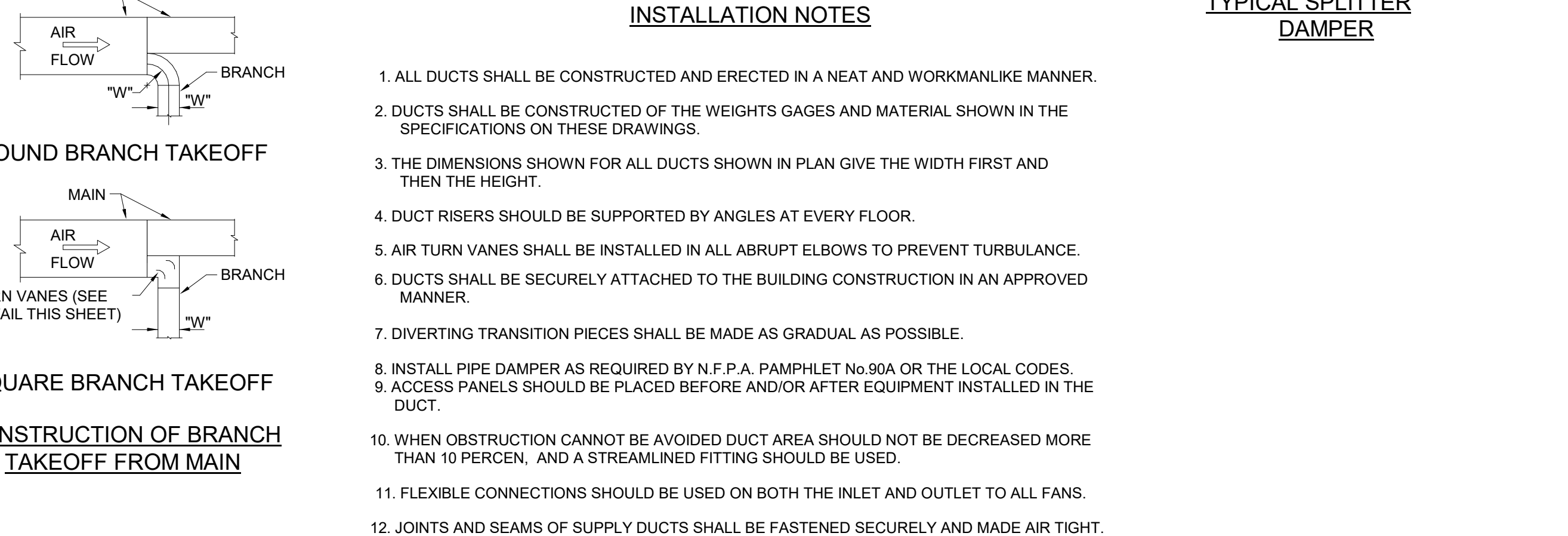
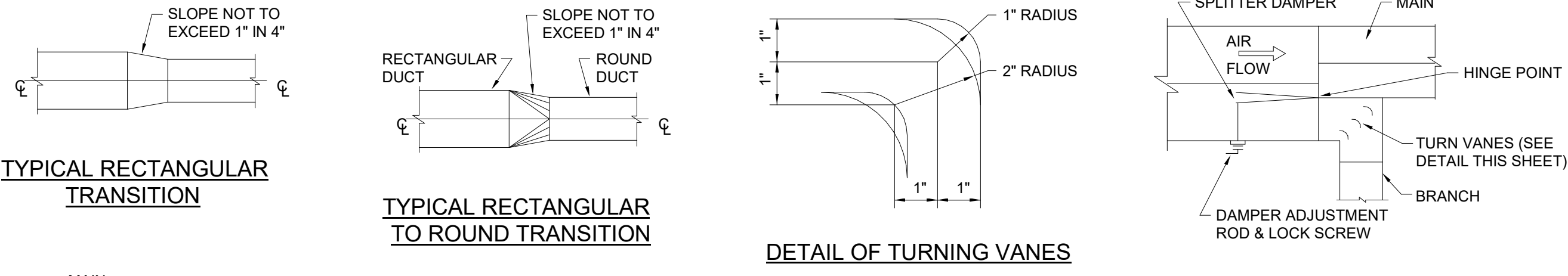
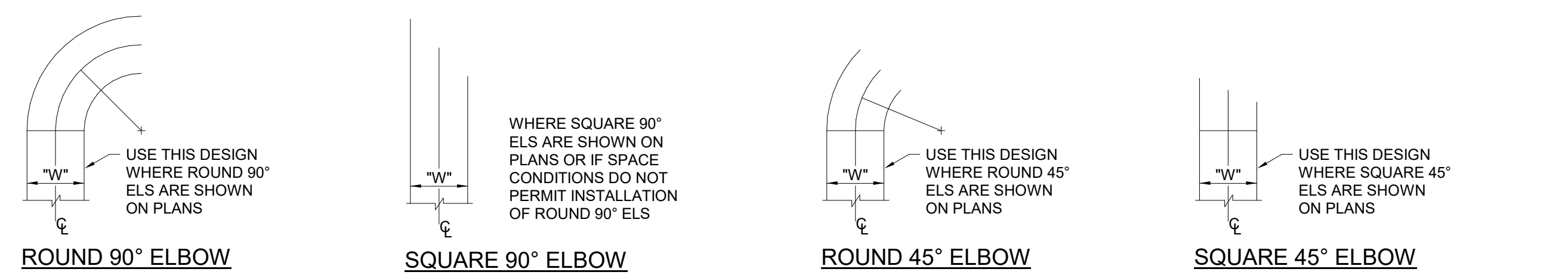

- INSTALLATION NOTES**
- ALL DUCTS SHALL BE CONSTRUCTED AND ERECTED IN A NEAT AND WORKMANLIKE MANNER.
 - DUCTS SHALL BE CONSTRUCTED OF THE WEIGHTS GAGES AND MATERIAL SHOWN IN THE SPECIFICATIONS ON THESE DRAWINGS.
 - THE DIMENSIONS SHOWN FOR ALL DUCTS SHOWN IN PLAN GIVE THE WIDTH FIRST AND THEN THE HEIGHT.
 - DUCT RISERS SHOULD BE SUPPORTED BY ANGLES AT EVERY FLOOR.
 - AIR TURN VANES SHALL BE INSTALLED IN ALL ABRUPT ELBOWS TO PREVENT TURBULANCE.
 - DUCTS SHALL BE SECURELY ATTACHED TO THE BUILDING CONSTRUCTION IN AN APPROVED MANNER.
 - DIVERTING TRANSITION PIECES SHALL BE MADE AS GRADUAL AS POSSIBLE.
 - INSTALL PIPE DAMPER AS REQUIRED BY N.F.P.A. PAMPHLET No 90A OR THE LOCAL CODES.
 - ACCESS PANELS SHOULD BE PLACED BEFORE AND/OR AFTER EQUIPMENT INSTALLED IN THE DUCT.
 - WHEN OBSTRUCTION CANNOT BE AVOIDED DUCT AREA SHOULD NOT BE DECREASED MORE THAN 10 PERCENT, AND A STREAMLINED FITTING SHOULD BE USED.
 - FLEXIBLE CONNECTIONS SHOULD BE USED ON BOTH THE INLET AND OUTLET TO ALL FANS.
 - JOINTS AND SEAMS OF SUPPLY DUCTS SHALL BE FASTENED SECURELY AND MADE AIR TIGHT.

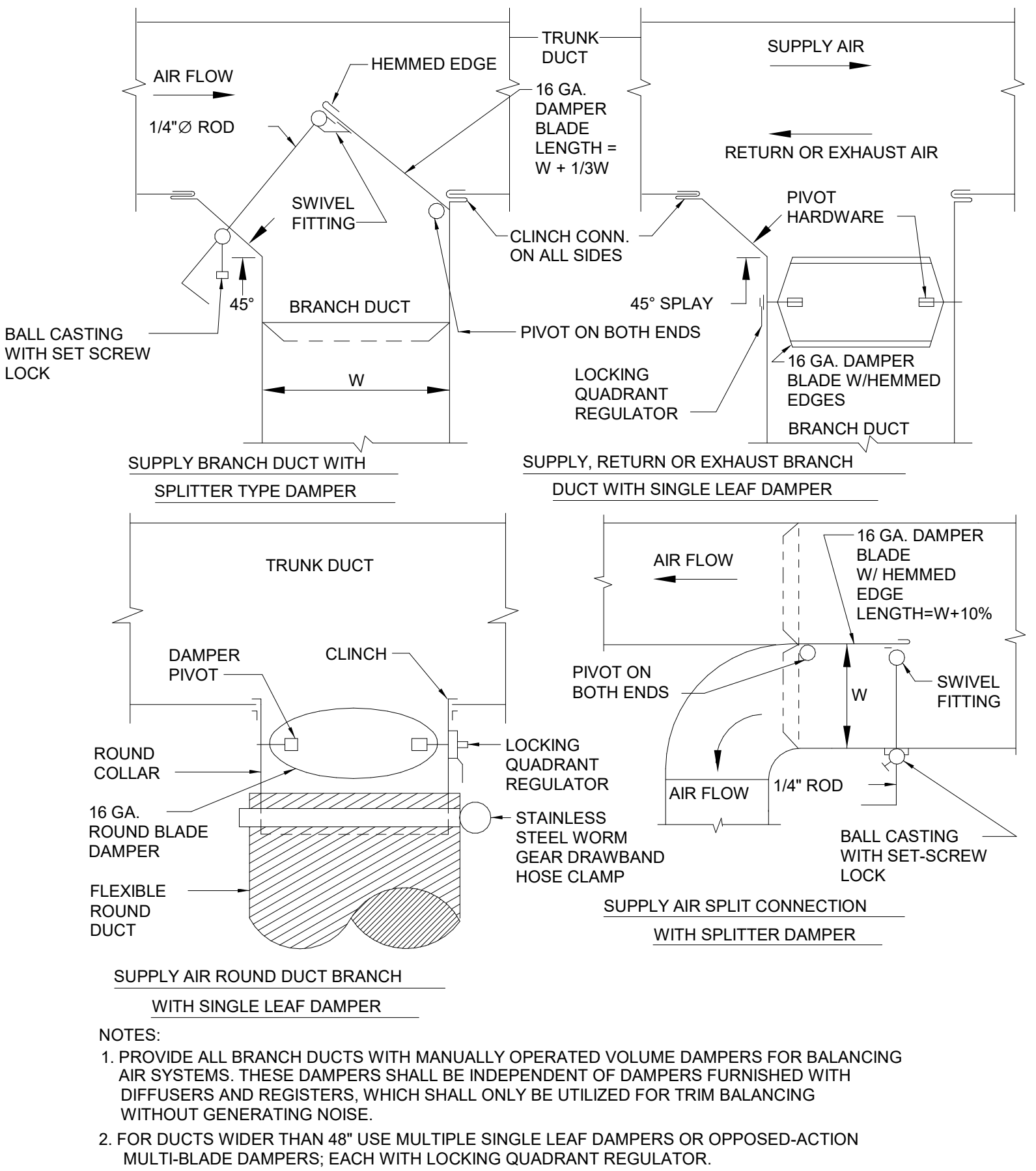

BRANCH DUCT VOLUME DAMPERS

- NOTES:**
- PROVIDE ALL BRANCH DUCTS WITH MANUALLY OPERATED VOLUME DAMPERS FOR BALANCING AIR SYSTEMS. THESE DAMPERS SHALL BE INDEPENDENT OF DAMPERS FURNISHED WITH DIFFUSERS AND REGISTERS, WHICH SHALL ONLY BE UTILIZED FOR TRIM BALANCING WITHOUT GENERATING NOISE.
 - FOR DUCTS WIDER THAN 48" USE MULTIPLE SINGLE LEAF DAMPERS OR OPPOSED-ACTION MULTI-BLADE DAMPERS; EACH WITH LOCKING QUADRANT REGULATOR.

LOW VELOCITY DUCT LAYOUT DETAILS

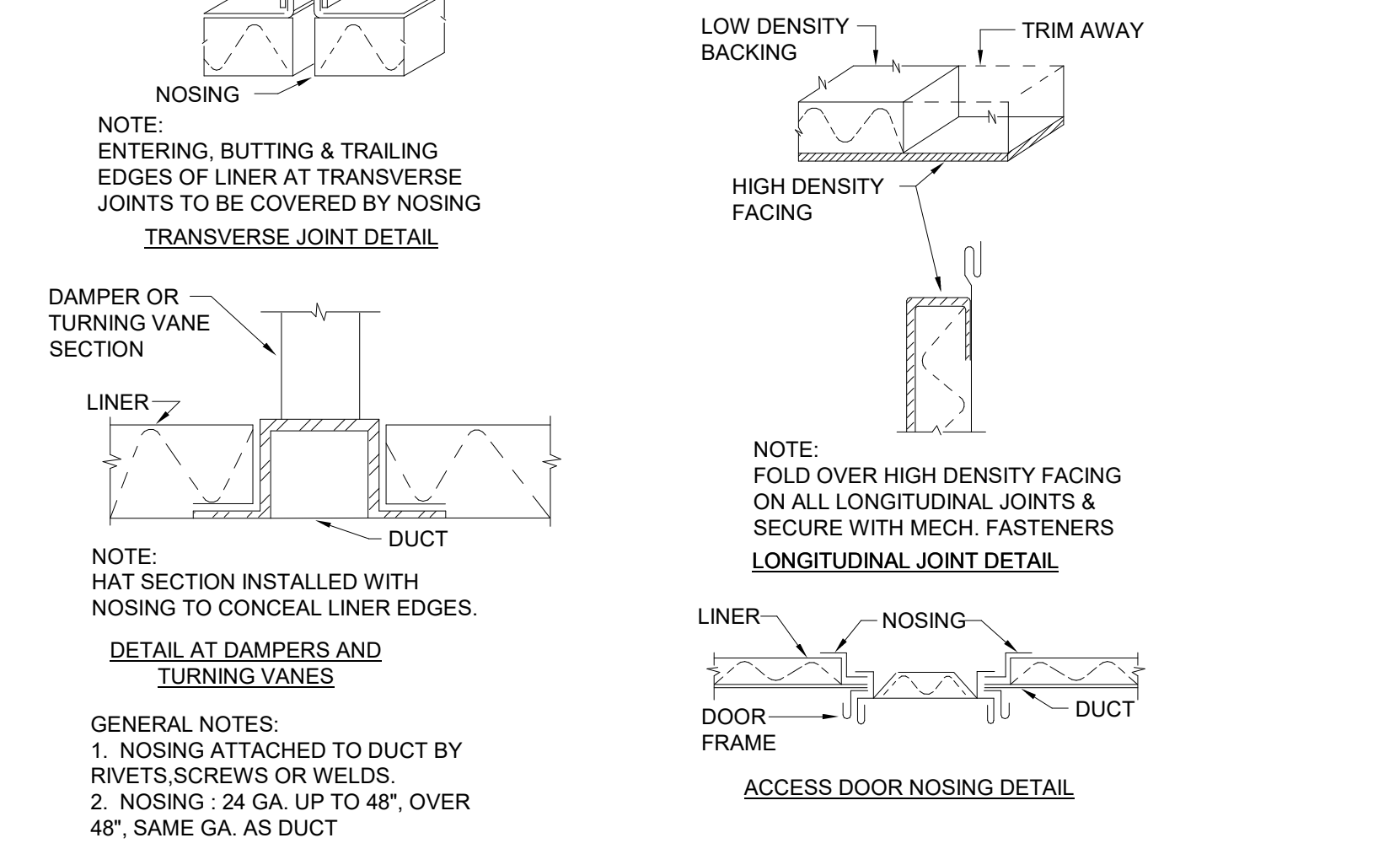
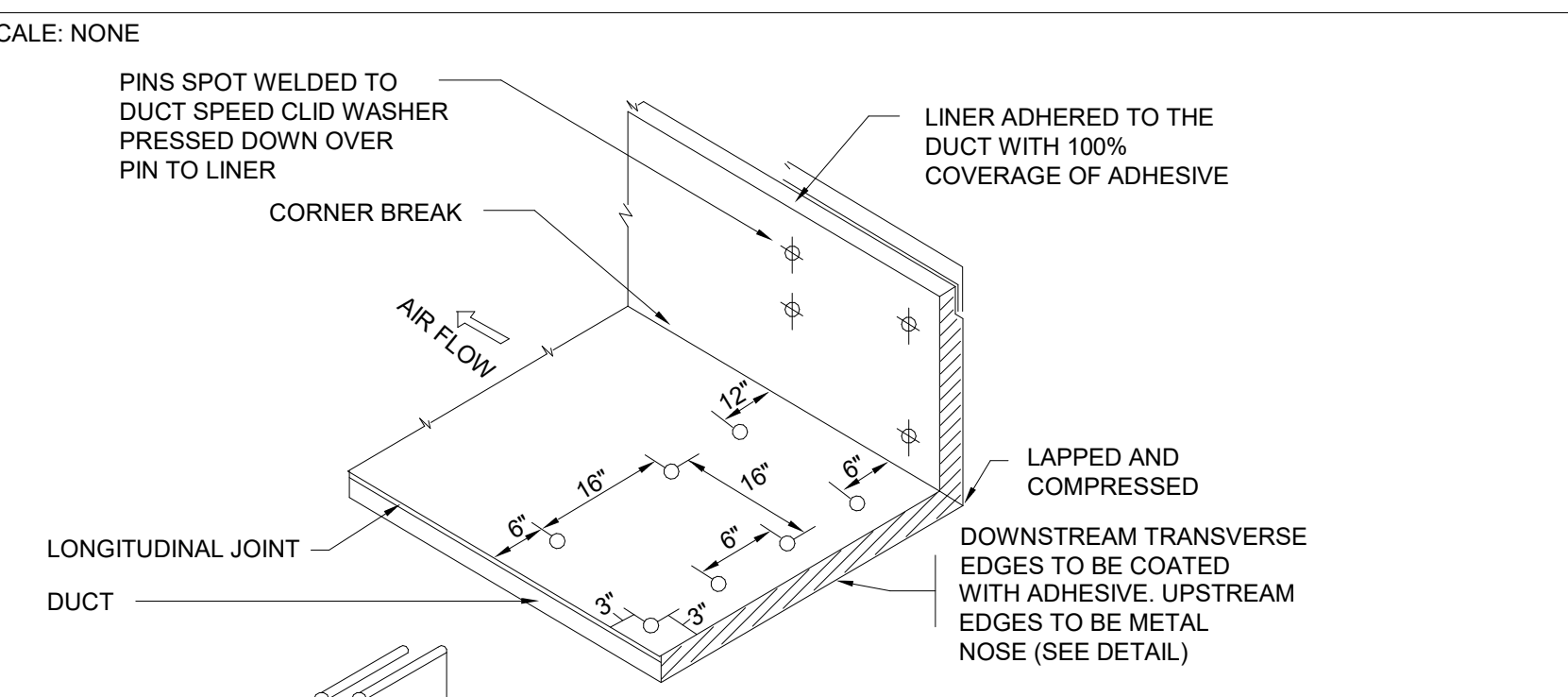

ACOUSTICAL DUCT LINER DETAIL

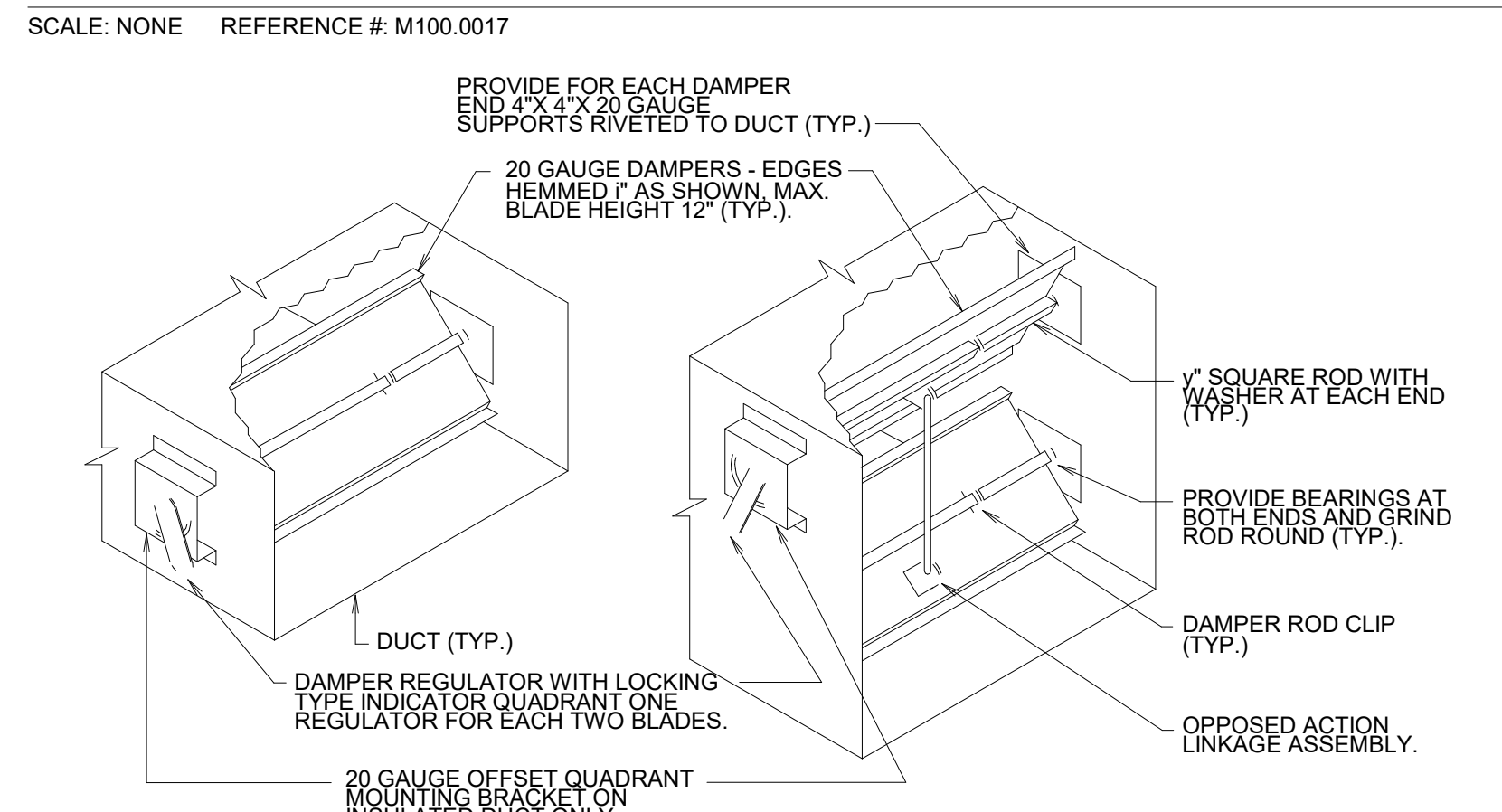
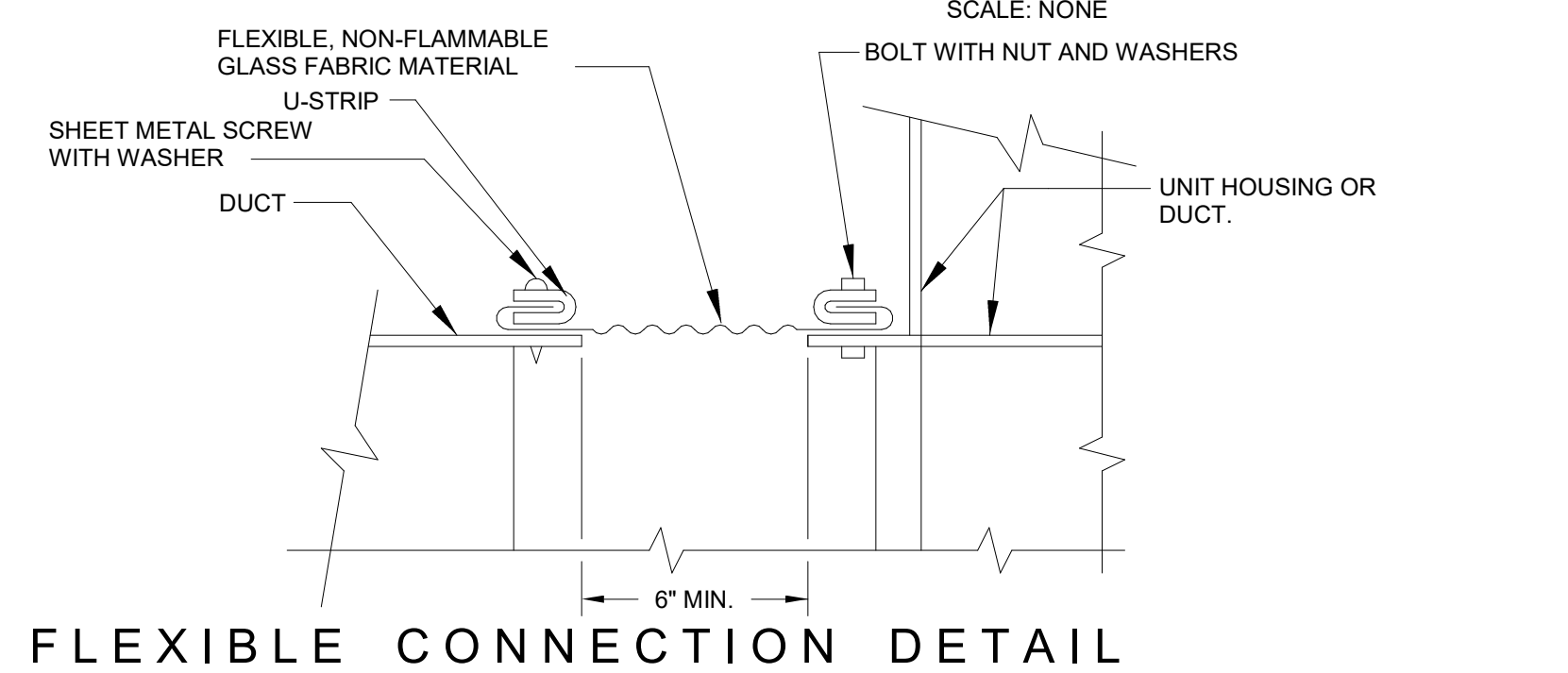

LOW PRESSURE BALANCING DAMPER

- NOTES:**
- USE SINGLE BLADE FOR DUCTS UP TO 12" HIGH AND LESS THAN 29" WIDE.
 - USE MULTIPLE BLADES FOR DUCTS GREATER THAN OR EQUAL TO 29" AND/OR OVER 12" HIGH.

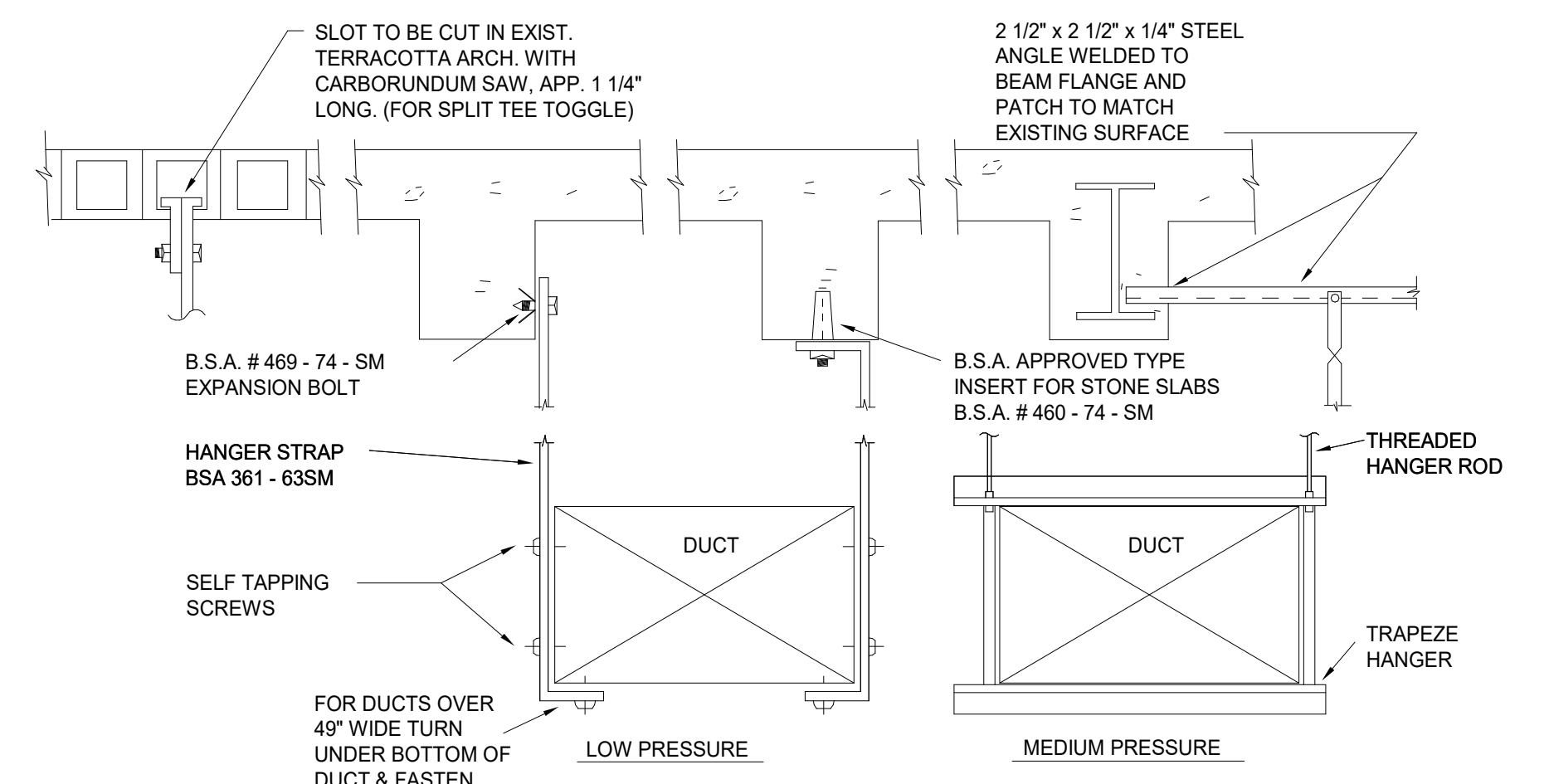

METHOD OF HANGING DUCTWORK

NOTE: DAMAGED OR REMOVED FIREPROOFING SHALL BE REPAIRED.

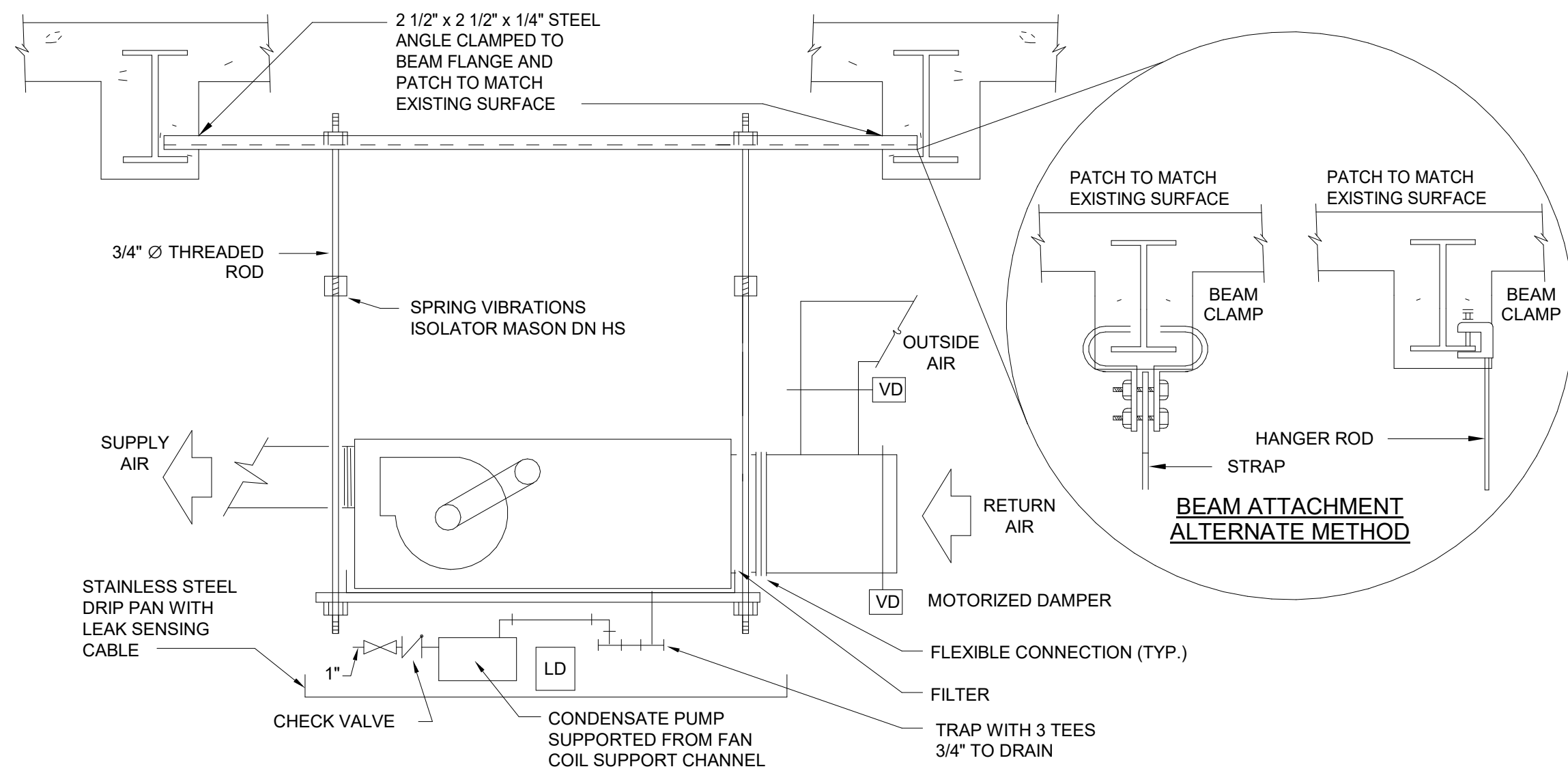

**AIR HANDLING UNIT
HANGING DETAIL**

SCALE: NONE

NOTE: DAMAGED OR REMOVED FIREPROOFING SHALL BE REPAIRED.

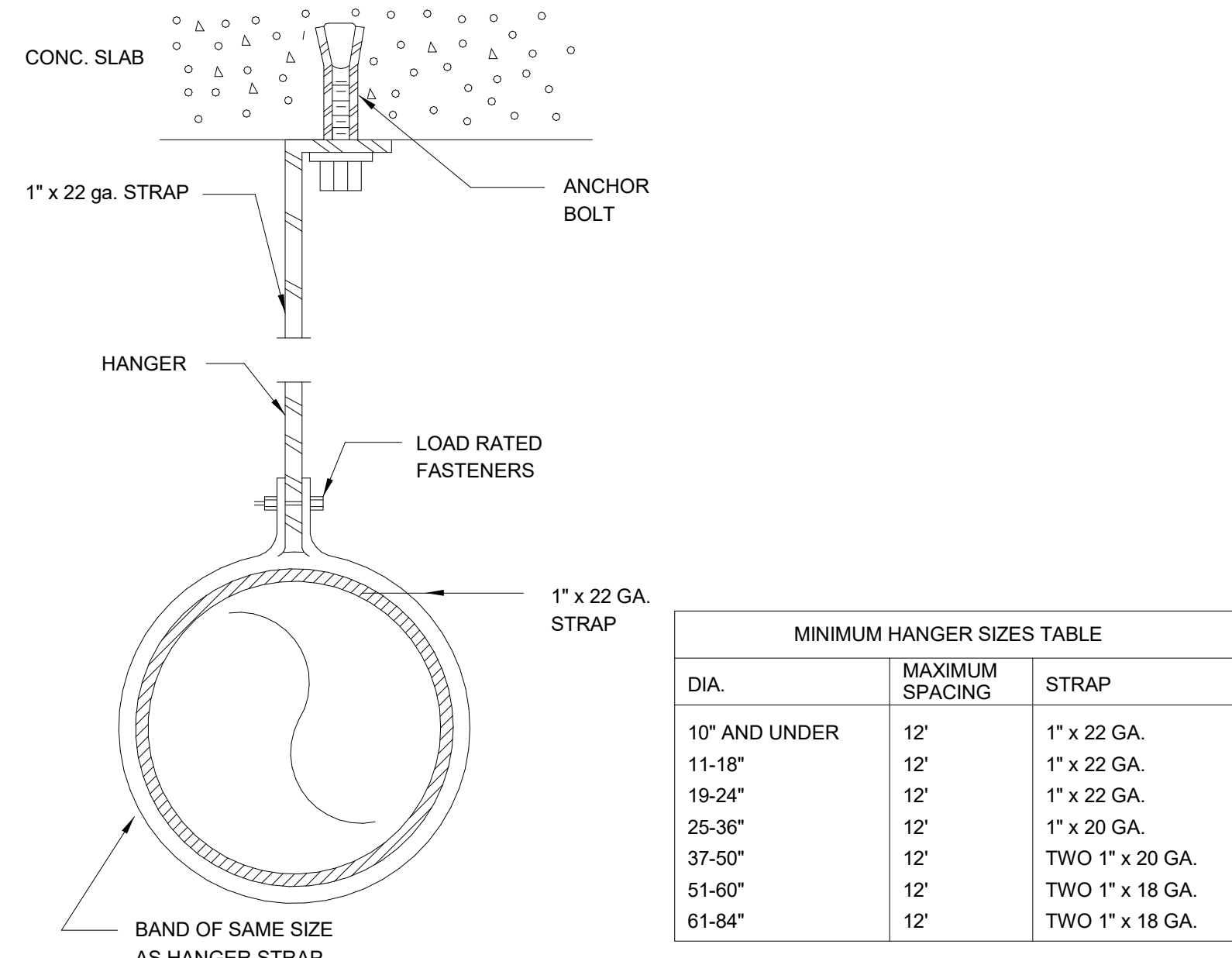

**TYPICAL ROUND
DUCT HANGER**

SCALE: NONE REFERENCE #: M100.057

MINIMUM HANGER SIZES TABLE		
DIA.	MAXIMUM SPACING	STRAP
10" AND UNDER	12"	1" x 22 GA.
11-18"	12"	1" x 22 GA.
19-24"	12"	1" x 22 GA.
25-36"	12"	1" x 20 GA.
37-50"	12"	TWO 1" x 20 GA.
51-60"	12"	TWO 1" x 18 GA.
61-84"	12"	TWO 1" x 18 GA.

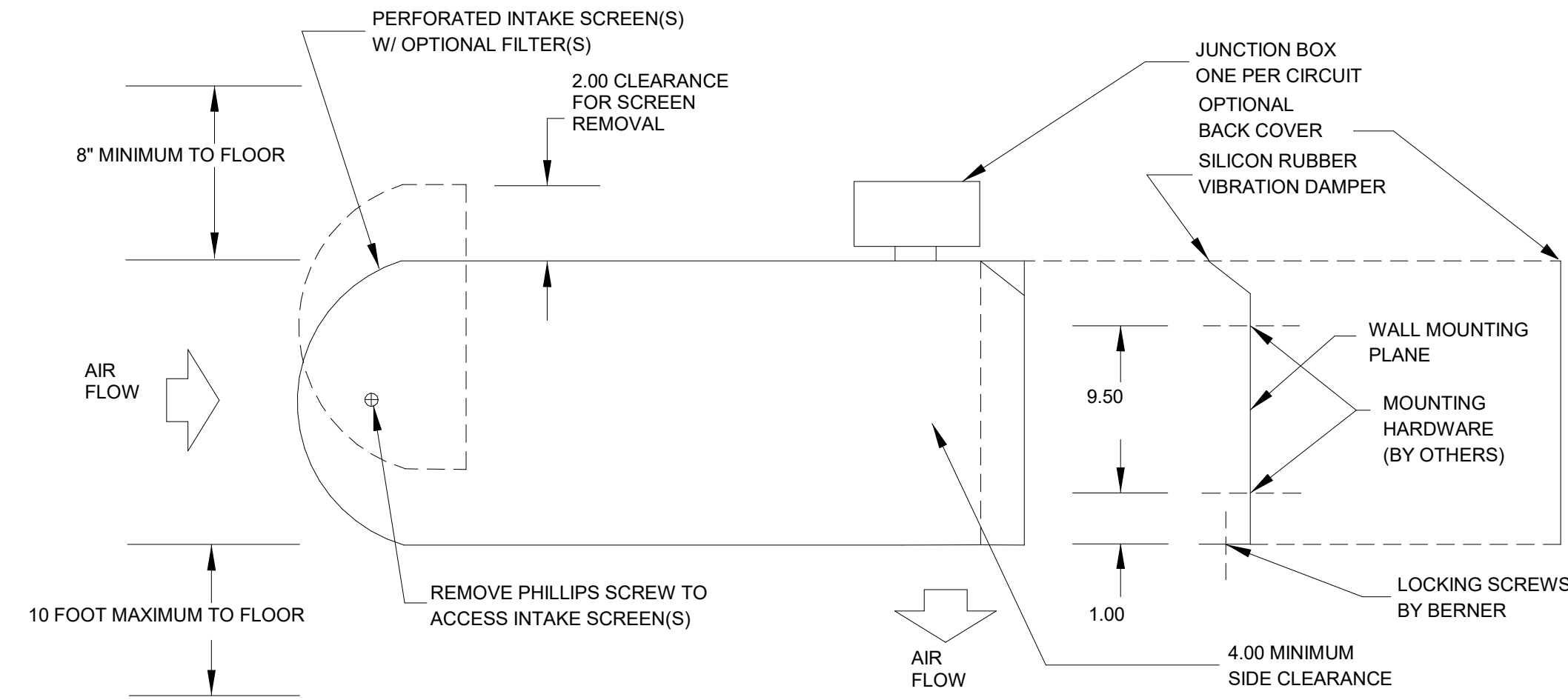

NOTES:

- 1 AIR CURTAIN MUST BE INSTALLED SO AIR STREAM IS NOT OBSTRUCTED WHEN DEFLECTED 20 DEGREES TO EITHER SIDE OF CL.
- 2 ELECTRICAL CONNECTIONS TO BE FLEXIBLE.
- 3 FIELD VERIFY DIMENSIONS.
- 4 ANCHORS TO SUPPORTING STRUCTURE BY OTHERS.
- 5 ADEQUACY OF SUPPORTING STRUCTURE IS TO BE VERIFIED BY A PROFESSIONAL ENGINEER.
- 6 DIMENSIONS IN INCHES UNLESS OTHERWISE NOTED.

AIR DOOR DETAIL

SCALE: NONE

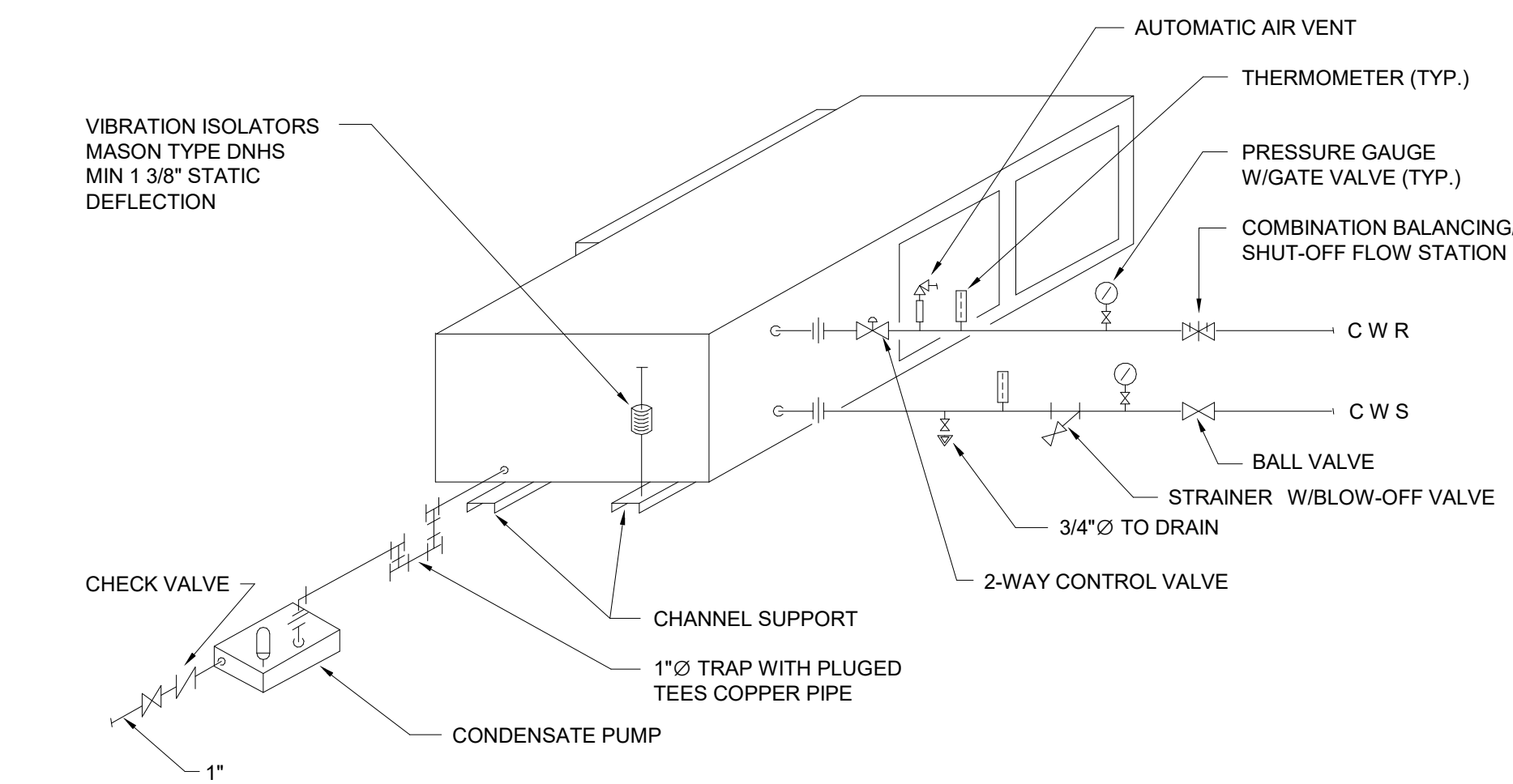

WATER COOLED UNIT PIPING DETAIL

SCALE: NONE REFERENCE #: M200.006

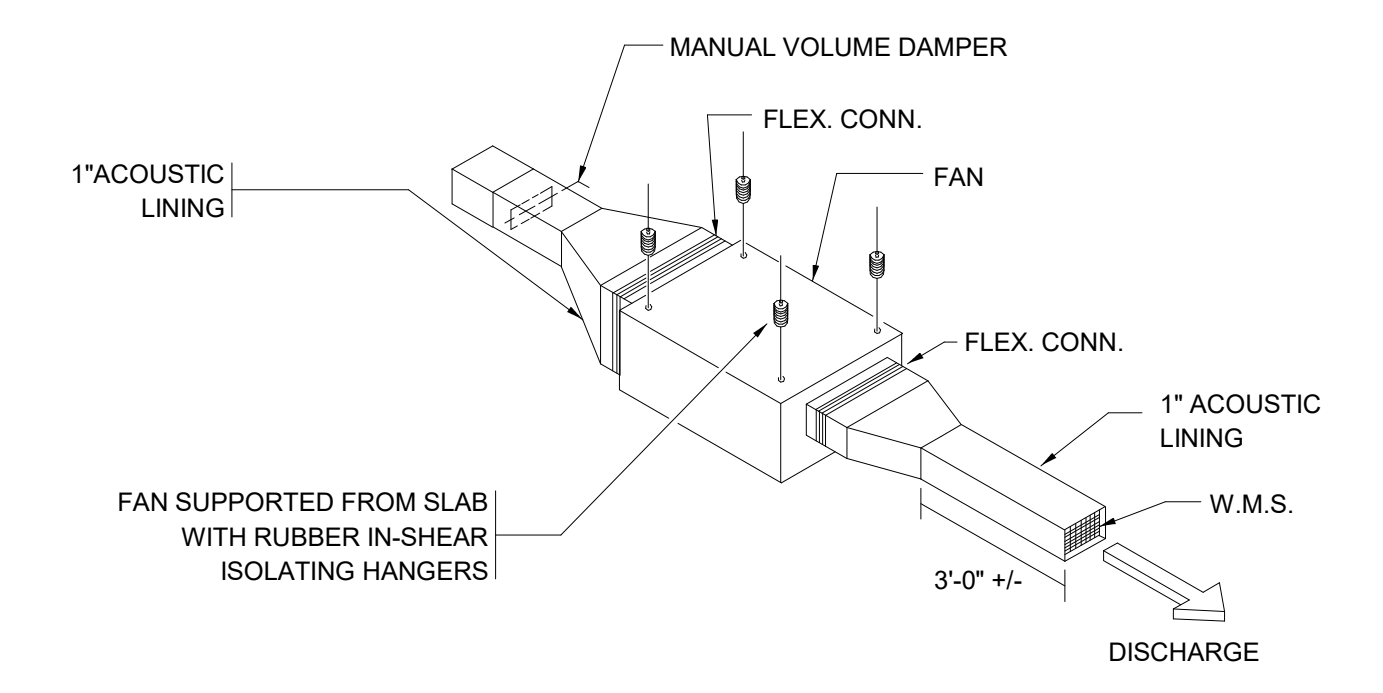

**INLINE FAN HANGING
SUPPORT DETAIL**

SCALE: NONE REFERENCE #: M400.013



sweetgreen

3101 W. EXPOSITION BLVD.
LOS ANGELES, CALIFORNIA 90018

THESE DRAWINGS & SPECIFICATIONS ARE CONFIDENTIAL AND SHALL REMAIN THE SOLE PROPERTY OF SWEETGREEN CORPORATION. THEY SHALL NOT BE REPRODUCED OR WHOLE OR IN PART, SHARED WITH THIRD PARTIES OR USED IN ANY MANNER ON OTHER PROJECTS OR EXTENSIONS TO THIS PROJECT WITHOUT THE PRIOR WRITTEN CONSENT OF SWEETGREEN CORPORATION. THESE DRAWINGS & SPECIFICATIONS ARE INTENDED TO EXPRESS DESIGN INTENT FOR A PROTOTYPICAL SWEETGREEN STORE WHICH IS SUBJECT TO CHANGE AT ANY TIME AND MAY NOT REFLECT ACTUAL SITE CONDITIONS. NEITHER PARTY SHALL HAVE ANY OBLIGATION OR LIABILITY TO THE OTHER (EXCEPT AS STATED ABOVE) UNTIL A WRITTEN AGREEMENT IS FULLY EXECUTED.

ARCHITECT OF RECORD:

**O'NEIL LANGAN
ARCHITECTS**
15 WEST 37TH STREET
15TH FLOOR
NEW YORK, NY 10018
PHONE: 212-279-2670
FAX: 212-279-2671

STAMP:

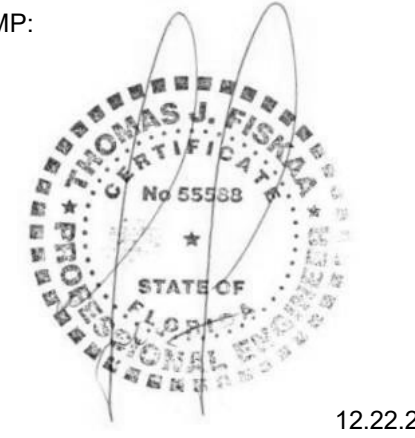

12.22.2021

PROJECT INFORMATION:
TAMPA HEIGHTS
PROJECT INFORMATION:
**301 West Palm Avenue
Tampa FL 33602**

DRAWN BY: Author
CHECKED BY: Checker
PROJECT MANAGER: RC
SG DESIGN MANAGER: JM
SG CONSTR. MANAGER: JD
PROJECT NO: 221186
TEMPLATE VERSION: 06.01.2020

REV.	DATE	DESCRIPTION
1	11.09.2021	SG REVIEW
1	11.23.2021	LL REVIEW
1	12.22.2021	PERMIT SET
2	04.04.2022	REVISION 2
3	05.26.2022	IFC
4	06.21.2022	FIELD REV 01

**H.V.A.C. DETAILS
SHEET 2 OF 2**

M-701

6/27/2022 9:54:59 AM