

FOR QUESTIONS, CALL THE
Highwoods Group
REGION 40
PHONE: (919) 875-0420
EMAIL: reg40@captiveaire.com

PATENT NUMBERS

AC-PSP (UNITED STATES) - US PATENT 7963830 B2.
AC-PSP WALL (CANADA) - CA PATENT 2820509.
AC-PSP ISLAND (CANADA) - CA PATENT 2520330.

SPECIFICATION: CAPTRATE® GREASE-STOP® SOLID FILTER

THE CAPTRATE GREASE-STOP SOLID FILTER IS A SINGLE-STAGE FILTER FEATURING A UNIQUE S-BAFFLE DESIGN IN CONJUNCTION WITH A SLOTTED REAR BAFFLE DESIGN, TO DELIVER EXCEPTIONAL FILTRATION EFFICIENCY.

FILTER IS STAINLESS STEEL CONSTRUCTION, AND SIZED TO FIT INTO STANDARD 2-INCH DEEP HOOD CHANNEL(S).

UNITS SHALL INCLUDE STAINLESS STEEL HANDLES AND A FASTENING DEVICE TO SECURE THE TWO COMPONENTS WHEN ASSEMBLED.

GREASE EXTRACTION EFFICIENCY PERFORMANCE SHALL REMOVE AT LEAST 75% OF GREASE PARTICLES FIVE MICRONS IN SIZE, AND 85% GREASE PARTICLES SEVEN MICRONS IN SIZE AND LARGER, WITH A CORRESPONDING PRESSURE DROP NOT TO EXCEED 1.0 INCHES OF WATER GAUGE.

THE CAPTRATE GREASE-STOP SOLID WAS TESTED TO ASTM STANDARD ASTM F2519-05, MANUFACTURER APPROVED FOR USE IN SOLID FUEL APPLICATIONS AS A SPARK ARRESTER.

EFFICIENCY VS. PARTICLE DIAMETER

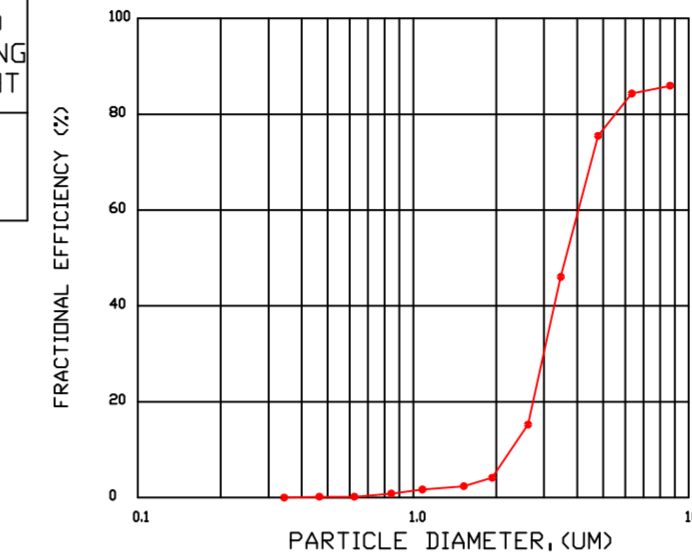

PRESSURE DROP VS. FLOW RATE

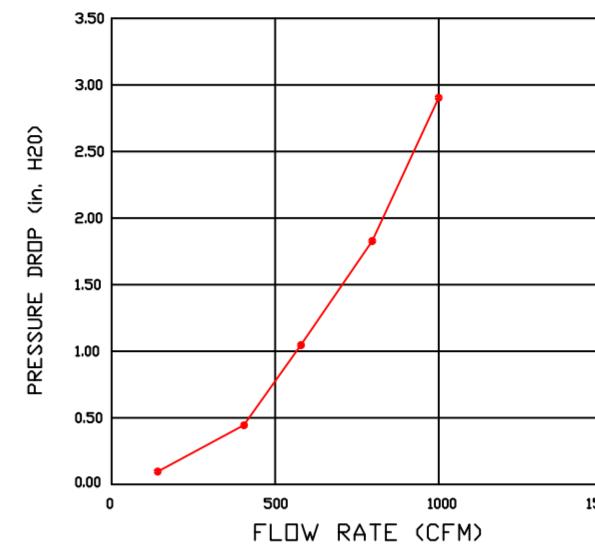

CAPTRATE FILTERS ARE BUILT IN COMPLIANCE WITH:
NFPA #96.
NSF STANDARD #2.
UL STANDARD #1046.
INT. MECH. CODE (IMC).
ULC-S649.



HOOD INFORMATION - JOB#5379525

HOOD NO	TAG	MODEL	MANUFACTURER	LENGTH	MAX COOKING TEMP	TYPE	APPLIANCE DUTY	DESIGN CFM/FT	TOTAL EXH CFM	EXHAUST PLENUM RISER(S)					MUA CFM	AC CFM	HOOD CONSTRUCTION	HOOD CONFIG		
										WIDTH	LENG	HEIGHT	DIA	CFM				VEL	SP	END TO END
1		5424 ND-2-ACPSP-F	CAPTIVEAIRE	14' 3"	600 DEG	I	HEAVY	225	3200	10"	15"	4"	1600	1536	-0.854"	1950	798	430 SS WHERE EXPOSED	ALONE	ALONE

HOOD INFORMATION

HOOD NO	TAG	FILTER(S)				LIGHT(S)				UTILITY CABINET(S)				FIRE SYSTEM PIPING	HOOD HANGING WEIGHT		
		TYPE	QTY	HEIGHT	LENGTH	EFFICIENCY @ 7 MICRONS	QTY	TYPE	WIRE GUARD	LOCATION	SIZE	FIRE SYSTEM TYPE	SIZE			ELECTRICAL MODEL #	SWITCHES QUANTITY
1		CAPTRATE SOLID FILTER	10	16"	16"	85% SEE FILTER SPEC	10	L55 SERIES E26	NO	RIGHT	12"x54"x24"	ANSUL R-102	3.0/3.0	SC-321110MA	1 LIGHT 1 FAN	YES	1061 LBS

HOOD OPTIONS

HOOD NO	TAG	OPTION
1		FIELD WRAPPER 6.00" HIGH FRONT, LEFT, RIGHT. RIGHT QUARTER END PANEL 23" TOP WIDTH, 0" BOTTOM WIDTH, 23" HIGH 430 SS. LEFT QUARTER END PANEL 23" TOP WIDTH, 0" BOTTOM WIDTH, 23" HIGH 430 SS. INSULATION FOR BACK OF HOOD. FULL DIMENSION HANGING BRACKET - FRONT.

PERFORATED SUPPLY PLENUM(S)

HOOD NO	TAG	POS	LENGTH	WIDTH	HEIGHT	TYPE	RISER(S)					
							MUA	WIDTH	LENG	DIA	CFM	SP
1		Front	183"	22"	6"	AC	10"	28"		650	0.166"	
							MUA	10"	28"		650	0.166"
							MUA	10"	28"		650	0.166"
							AC		8"	114	0.041"	
							AC		8"	114	0.041"	
							AC		8"	114	0.041"	
							AC		8"	114	0.041"	
							AC		8"	114	0.041"	
							AC		8"	114	0.041"	
							AC		8"	114	0.041"	

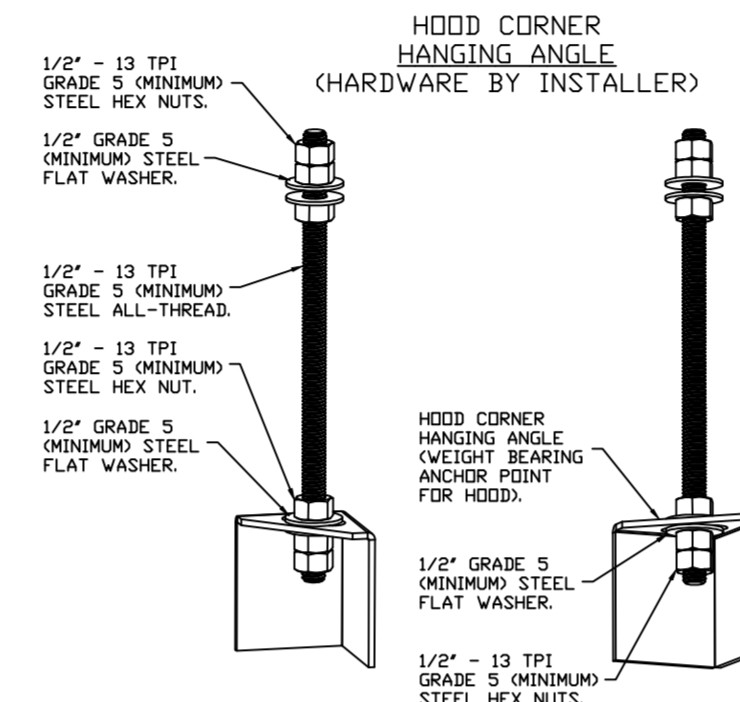

ASSEMBLY INSTRUCTIONS

HANGING ANGLE MUST BE SUPPORTED WITH 1/2" - 13 TPI GRADE 5 (MINIMUM) ALL-THREAD. SANDWICH HANGING ANGLES AND CEILING ANCHOR POINTS WITH 1/2" GRADE 5 (MINIMUM) STEEL FLAT WASHERS AND 1/2" - 13 TPI GRADE 5 (MINIMUM) HEX NUTS AS SHOWN. MUST USE DOUBLED HEX NUT CONFIGURATION BENEATH HOOD HANGING ANGLES AND ABOVE CEILING ANCHORS. MAINTAIN 1/4" OF EXPOSED THREADS BENEATH BOTTOM HEX NUT. TORQUE ALL HEX NUTS TO 57 FT-LBS.

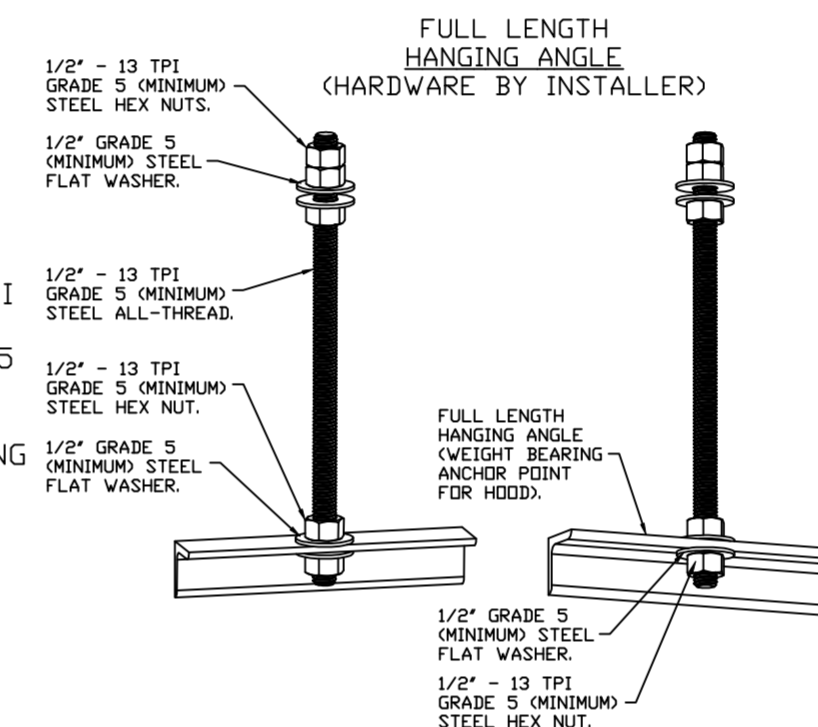

ASSEMBLY INSTRUCTIONS

HANGING ANGLE MUST BE SUPPORTED WITH 1/2" - 13 TPI GRADE 5 (MINIMUM) ALL-THREAD. SANDWICH HANGING ANGLES AND CEILING ANCHOR POINTS WITH 1/2" GRADE 5 (MINIMUM) STEEL FLAT WASHERS AND 1/2" - 13 TPI GRADE 5 (MINIMUM) HEX NUTS AS SHOWN. MUST USE DOUBLED HEX NUT CONFIGURATION ABOVE CEILING ANCHORS. SINGLE HEX NUT BENEATH HANGING ANGLE IS ACCEPTABLE FOR FULL LENGTH HANGING ANGLES. MAINTAIN 1/4" OF EXPOSED THREADS BENEATH BOTTOM HEX NUT. TORQUE ALL HEX NUTS TO 57 FT-LBS.

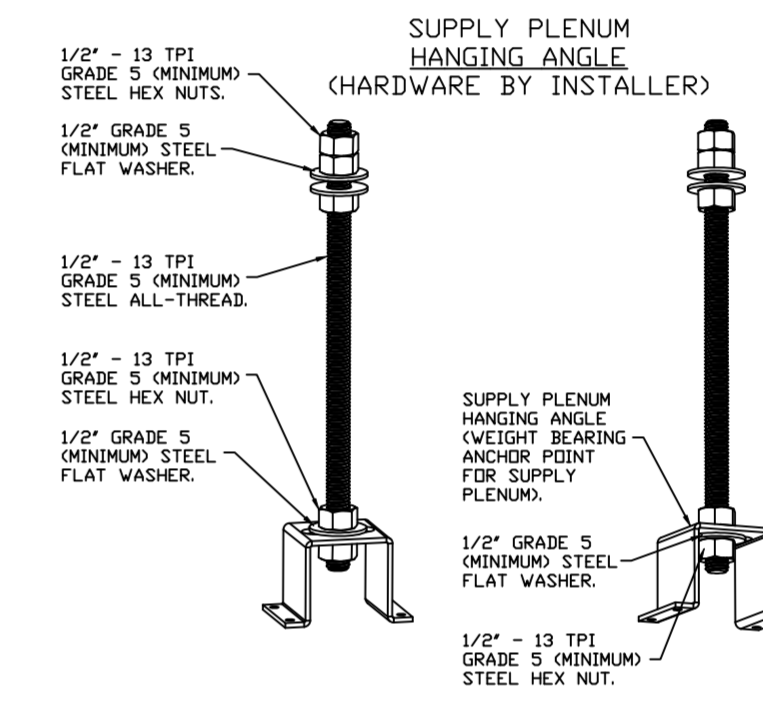

ASSEMBLY INSTRUCTIONS

HANGING ANGLE MUST BE SUPPORTED WITH 1/2" - 13 TPI GRADE 5 (MINIMUM) ALL-THREAD. SANDWICH HANGING ANGLES AND CEILING ANCHOR POINTS WITH 1/2" GRADE 5 (MINIMUM) STEEL FLAT WASHERS AND 1/2" - 13 TPI GRADE 5 (MINIMUM) HEX NUTS AS SHOWN. MUST USE DOUBLED HEX NUT CONFIGURATION ABOVE CEILING ANCHORS. SINGLE HEX NUT BENEATH HANGING ANGLE IS ACCEPTABLE FOR PSP HANGING ANGLES. MAINTAIN 1/4" OF EXPOSED THREADS BENEATH BOTTOM HEX NUT. TORQUE ALL HEX NUTS TO 57 FT-LBS.

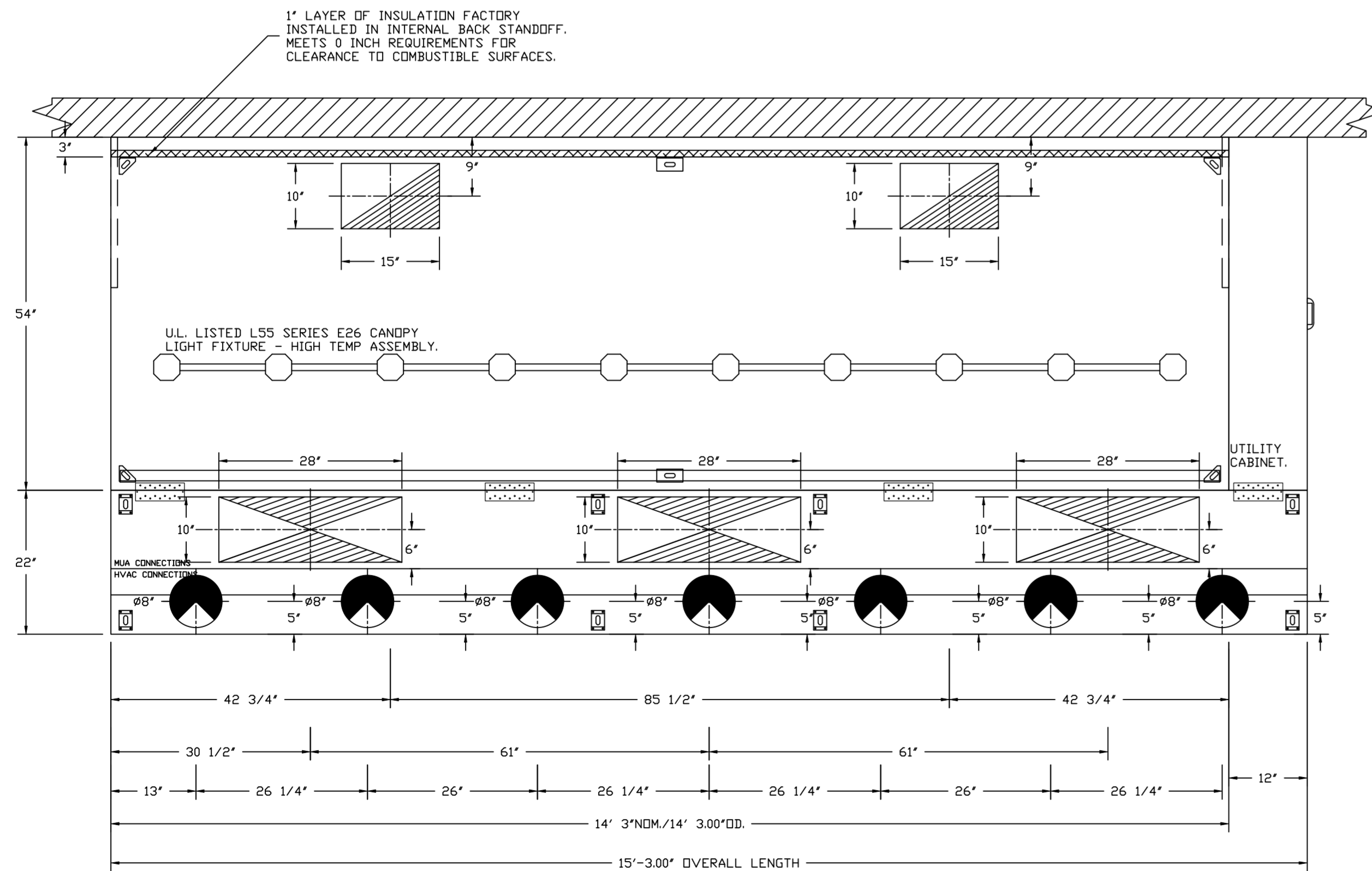

PLAN VIEW - HOOD #1
14' 3.00" LONG 5424ND-2-ACPSP-F
NOTE: ADDITIONAL HANGING ANGLES PROVIDED FOR HOODS 12' AND LONGER.

ACPSP SHIPS LOOSE FOR FIELD INSTALLATION

REVISIONS

DESCRIPTION	DATE

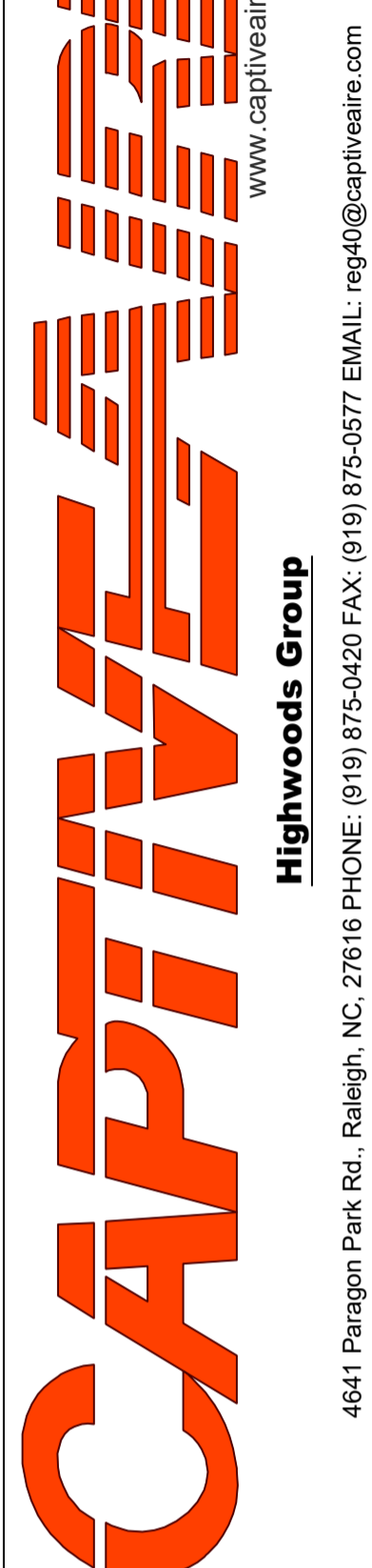
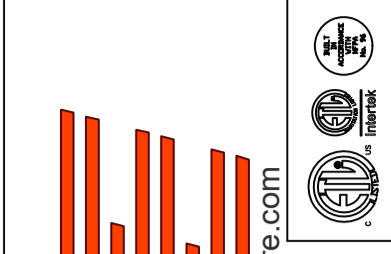

CHIPOTLE LONGWOOD #4245
LONGWOOD, FL, 32779

DATE: 3/15/2022

DWG.#:
5379525

DRAWN BY:
JMB-40

SCALE:
3/4" = 1'-0"

MASTER DRAWING

SHEET NO.
1

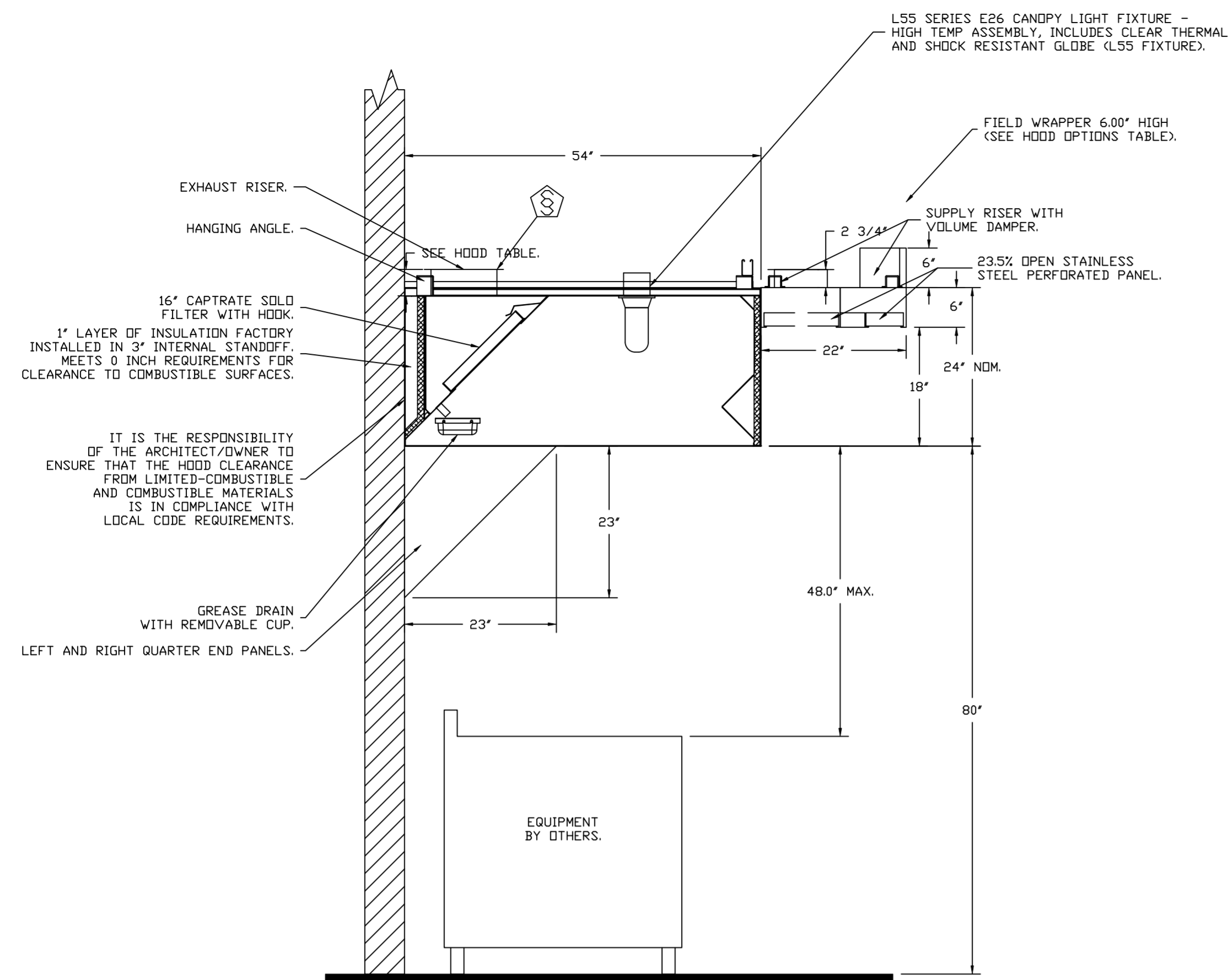

SECTION VIEW - MODEL 5424ND-2-ACPSP-F
HOOD - #1

FIRE SYSTEM INFORMATION - JOB#5379525

FIRE SYSTEM NO	TAG	TYPE	SIZE	FLOW POINTS	INSTALLATION	
					SYSTEM	LOCATION ON HOOD
1		ANSUL R102	3.0/3.0	13	FIRE CABINET RIGHT	RIGHT, HOOD 1

GAS VALVE(S)

FIRE SYSTEM NO	TAG	TYPE	SIZE	SUPPLIED BY
1		MECHANICAL	1.500	CAPTIVEAIRE SYSTEMS

REVISIONS

NO.	DESCRIPTION	DATE

CAPTIVEAIRE
Highwoods Group
www.captiveaire.com
4641 Paragon Park Rd., Raleigh, NC 27616 PHONE: (919) 875-0420 FAX: (919) 875-0577 EMAIL: reg@captivaire.com

CHIPOTLE LONGWOOD #4245
LONGWOOD, FL, 32779

DATE: 3/15/2022
DWG.#: 5379525
DRAWN BY: JMB-40
SCALE: 3/4" = 1'-0"
MASTER DRAWING

SHEET NO.
2

SPECIFICATIONS

TAG: Commercial Kitchen Ventilation Hoods, Listed Commercial Kitchen Hoods

PART 1 - GENERAL

1.1 SUMMARY

- A. The ND2 series is a Type I, wall canopy hood for use over 600°F cooking surface temperatures. The aerodynamic design includes a mechanical baffle and performance enhancing lip for exceptional capture and containment.
- B. The hood shall have the size, shape, and performance specified on drawings.

1.2 SUBMITTALS

- A. The manufacturer assumes no liability for the use or results of use from this document. Specifications are to be reviewed by the engineer to confirm the project's requirements and meet Federal, State, and Local codes and regulations.
- B. As the manufacturer continues product development, it reserves the right to change design and specifications without notice.
- C. The manufacturer shall supply complete computer generated submittal drawings, including hood section view(s) and hood plan view(s). These drawings must be available to the engineer, architect, and owner for their use in construction, operation, and maintenance.

1.3 QUALITY ASSURANCE

- A. This hood is ETL-listed to standard UL710, ULC710, and ULC-S646 when installed in accordance with these installation instructions and National Fire Protection Association Standard NFPA 96, Standard for Ventilation Control and Fire Protection of Commercial Cooking Operations."
- B. Built-in compliance with NSF/ANSI Standard 2.
- C. The hood shall be ETL Listed as:
 1. "Exhaust Hood Without Exhaust Damper."
 2. ETL Sanitation Listed and built in accordance with NFPA 96.
 3. The ETL label shall list temperature rating(s) and minimum CFM/ft rating(s).

1.4 WARRANTY

- A. All units shall be provided with the following standard warranty:
 1. This equipment is warranted to be free from defects in materials and workmanship, under normal use and service, for a period of 2-years from date of shipment.
- B. The manufacturer shall not be liable for incidental and consequential losses and damages potentially attributable to malfunctioning equipment. Should any part of the equipment prove to be defective in material or workmanship within the 2-year warranty period, upon examination by the manufacturer, such part will be repaired or replaced by manufacturer at no charge. The buyer shall pay all labor costs incurred in connection with such repair or replacement. Equipment shall not be returned without manufacturer's prior authorization, and all returned equipment shall be shipped by the buyer, freight prepaid to a destination determined by the manufacturer.
- C. Refer to Manufacturer's Operation, Installation, and Maintenance (OIM) Manual for detailed descriptions of what is/is not covered and contact information for warranty claims.

PART 2 - PRODUCTS

2.1 GENERAL

- A. Construction shall be dependent on the structural application to minimize distortion and other defects. All seams, joints, and penetrations of the hood enclosure to the lower outermost perimeter, which directs and captures grease-laden vapor and exhaust gases, shall have a liquid-tight continuous external weld in accordance with NFPA 96.

- B. Duct sizes, CFM, and static pressure requirements shall be as shown on drawings. Static pressure requirements shall be precise and accurate; air velocity and volume information shall be accurate within 1-ft increments along the length of the ventilator.

2.2 CONSTRUCTION

- A. Construction shall be type 430 stainless steel.
- B. Double wall insulated front to eliminate condensation and increase rigidity on wide sizes. The insulation shall have a flexural modulus of 475 EI, meet UL 181 requirements and be in accordance with NFPA 90A and 90B.
- C. Hood shall be equipped with a minimum of four connections for hanger rods. Hood lengths greater than 12' will have added hangers.
- D. Exhaust duct collar to be 4" high with flange.
- E. The grease drain system shall be an enclosed integral part of the hood back and have slopes with an exposed, removable 1/2 grease cup to facilitate cleaning.
- F. An integral baffle to direct grease laden vapors toward the exhaust filter bank.
- G. Hood shall be furnished with UL classified filters, supplied in size and quantity as required by ventilator.
- H. All seams shall be welded and have stainless steel on exposed surfaces.

2.3 LIGHTING

- A. L55 Series canopy light fixture, includes clear thermal and shock resistant globe.

2.4 FILTERS

- A. Stainless Steel Captrate Solo filter with hook, ETL Listed. Particulate capture efficiency: 85% efficient at 9 microns, 76% efficient at 5 microns.

2.5 OPTIONS

- A. Fire Suppression System: UL 300 fire suppression system.
- B. Optional perforated supply plenum shall provide make-up air discharged below the cooking equipment.
 1. Perforated diffuser plates shall be included in the design to provide even air distribution.
 2. Unexposed surfaces shall be constructed of aluminized steel. Plenum shall be insulated to prevent condensation.
 3. Dual Plenum (AC-PSP)
- C. Hood Mounted Utility Cabinet - Cabinet can store listed fire suppression system, listed components, pre-wired electrical controls.

2.6 ACCESSORIES

- A. End Panel(s) maximize hood performance and eliminate the effects of cross drafts in the kitchen. Units constructed of stainless steel and sized according to hood width and cooking equipment. Exposed edges hemmed for safety and rigidity. Selected panels:
 1. Quarter End Panel
- B. Wrapper(s) may be installed from the factory or field installed. Wrapper(s) selected:
 1. Wrapper
- C. Miscellaneous option(s) selected:
 1. Full Dimension Hanging Bracket -Unistrut added to allow for various hood mounting locations.
 2. Insulation for Back of Hood -Backside of hood is fully insulated.

PART 3 - EXECUTION

3.1 EXAMINATION

- A. Examine areas and conditions under which the system is installed. Do not proceed with work until unsatisfactory conditions have been

corrected in a manner acceptable to Installer.

3.2 INSTALLATION

- A. Install in accordance with manufacturer's instructions, drawings, written specifications, manufacturer's installation manual, and all applicable building codes.

REVISIONS	
DESCRIPTION	DATE
△	
△	
△	
△	

Highwoods Group
 4641 Paragon Park Rd., Raleigh, NC, 27616 PHONE: (919) 875-0420 FAX: (919) 875-0577 EMAIL: reg10@captiveware.com

CHIPOTLE LONGWOOD #4245
 LONGWOOD, FL, 32779

DATE: 3/15/2022
DWG.#: 5379525
DRAWN BY: JMB-40
SCALE: 3/4" = 1'-0"
MASTER DRAWING

SHEET NO.
3

EXHAUST FAN INFORMATION - JOB#5379525

FAN UNIT NO	TAG	QTY	FAN UNIT MODEL #	MANUFACTURER	CFM	ESP	RPM	MOTOR ENCL	HP	BHP	PHASE	VOLT	FLA	DISCHARGE VELOCITY	WEIGHT (LBS)	SONES
1	EF-1	1	DU85HFA	CAPTIVEAIRE	1600	1.200	1384	TEAD-ECM	0.750	0.4790	1	115	8.9	506 FPM	88	13
2	EF-2	1	DU85HFA	CAPTIVEAIRE	1600	1.200	1384	TEAD-ECM	0.750	0.4790	1	115	8.9	506 FPM	88	13
3	EF-2	1	DR12HFA	CAPTIVEAIRE	150	0.600	1282	TEAD-ECM	0.250	0.0930	1	115	2.9		51	7.1

MUA FAN INFORMATION - JOB#5379525

FAN UNIT NO	TAG	QTY	FAN UNIT MODEL #	BLOWER	HOUSING	MIN CFM	DESIGN CFM	ESP	RPM	MOTOR ENCL	HP	BHP	PHASE	VOLT	FLA	MCA	MOCP	WEIGHT (LBS)	SONES
4	MAU-1	1	A1-D.250-15D	15MF-1-MDD	A1-D.250	1000	1950	0.500	2050	DDP,PREMIUM	2.000	1.3290	3	208	5.4	6.8A	15A	517	21

GAS FIRED MAKE-UP AIR UNIT(S)

FAN UNIT NO	TAG	INPUT BTUs	OUTPUT BTUs	TEMP RISE	REQUIRED INPUT GAS PRESSURE	GAS TYPE	BURNER EFFICIENCY(%)
4	MAU-1	74570	68604	33°F	7 IN. W.C. - 14 IN. W.C.	NATURAL	92

FAN OPTIONS

FAN UNIT NO	TAG	QTY	DESCRIPTION
1	EF-1	1	GREASE BOX
		1	MIAMI DADE CERTIFICATION - NOA-1 ALUMINUM UPBLAST
		1	ECM WIRING PACKAGE - PWM SIGNAL FROM ECPM03 PREWIRE (TELCO MOTOR), CCW ROTATION
2	EF-2	1	GREASE BOX
		1	MIAMI DADE CERTIFICATION - NOA-1 ALUMINUM UPBLAST
		1	ECM WIRING PACKAGE - PWM SIGNAL FROM ECPM03 PREWIRE (TELCO MOTOR), CCW ROTATION
3	EF-2	1	2 YEAR PARTS WARRANTY
		1	I 12-BDD DAMPER
		1	ECM WIRING PACKAGE - MANUAL OR 0-10VDC REFERENCE SPEED CONTROL (TELCO MOTOR), CCW ROTATION
4	MAU-1	1	MIAMI DADE CERTIFICATION - NOA-1 ALUMINUM DOWNBLAST 10
		1	2 YEAR PARTS WARRANTY
		1	MOTORIZED BACKDRAFT DAMPER FOR A1-D HOUSING - MEETS AMCA CLASS 1A RATING
		1	LOW FIRE START
		1	INLET PRESSURE GAUGE, 0-35"
		1	MANIFOLD PRESSURE GAUGE, -5 TO 15" WC
		1	SIZE 1 TEMPERED COMMERCIAL DOWN DISCHARGE FOR DIRECT DRIVE AHUS
		1	MIAMI DADE CERTIFICATION - NOA-2 SUPPLY
		1	SEPARATE 120V WIRING PACKAGE (REQUIRED AND USED ONLY FOR DCV OR PREWIRE WITH VFD) - THREE PHASE ONLY
		1	UNIT MOUNTED VFD FOR USE WITH ECPM03
1	2 YEAR PARTS WARRANTY		

FAN ACCESSORIES

FAN UNIT NO	TAG	EXHAUST				SUPPLY		
		GREASE CUP	GRAVITY DAMPER	WALL MOUNT	SIDE DISCHARGE	GRAVITY DAMPER	MOTORIZED DAMPER	WALL MOUNT
1	EF-1	YES						
2	EF-2	YES						
3	EF-2		YES					
4	MAU-1						YES	

CURB ASSEMBLIES

NO	ON FAN	TAG	WEIGHT	ITEM	SIZE
1	# 1	EF-1	66 LBS	CURB	23.000"W X 23.000"L X 26.000"H ALONG LENGTH, RIGHT VENTED 16 GAUGE.
2	# 2	EF-1	66 LBS	CURB	23.000"W X 23.000"L X 26.000"H ALONG LENGTH, RIGHT VENTED 16 GAUGE.
3	# 3	EF-2	51 LBS	CURB	17.500"W X 17.500"L X 26.000"H ALONG LENGTH, RIGHT 16 GAUGE.
4	# 4	MAU-1	108 LBS	CURB	21.000"W X 71.000"L X 20.000"H ALONG WIDTH, RIGHT INSULATED 16 GAUGE.

MIAMI-DADE NOA2 SUPPLY FANS

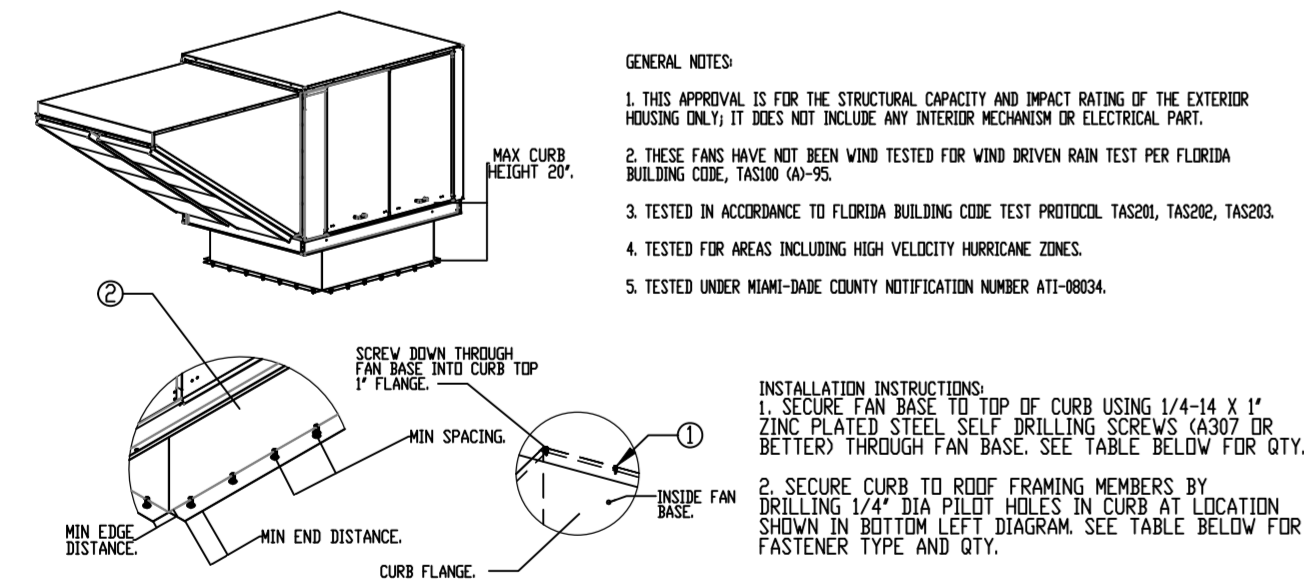

DESIGN PRESSURE: +30 / -100 PSF. LARGE MISSILE IMPACT RESISTANT.

INSTALLATION FASTENER TYPES			
FAN TO CURB	WOOD (SG = 0.42 MIN.)	STEEL (12 GAUGE MIN.)	CONCRETE (2500 PSI MIN. CRACKED CONCRETE)
FASTENER	1/4" X 1" SELF DRILLING SCREW (A307 OR BETTER)	3/8" DIA. ZINC PLATED LAG BOLT	3/8" DIA. SS HILTI KWIK BOLT T2 EXPANSION ANCHOR
MINIMUM THREAD PENETRATION	N/A	2"	2-5/16"
MINIMUM EDGE DISTANCE	N/A	1-1/2"	3"
MINIMUM END DISTANCE	N/A	2-5/8"	4"
MINIMUM SPACING	N/A	1-1/2"	7"

INSTALLATION FASTENER QTY			
FAN MODEL	CURB TO FAN (WOOD)	STEEL	CONCRETE
	LONG SIDE	SHORT SIDE	TOTAL
DIRECT FIRED 1	5	2	14
	8	3	22
	6	2	16
	7	2	18

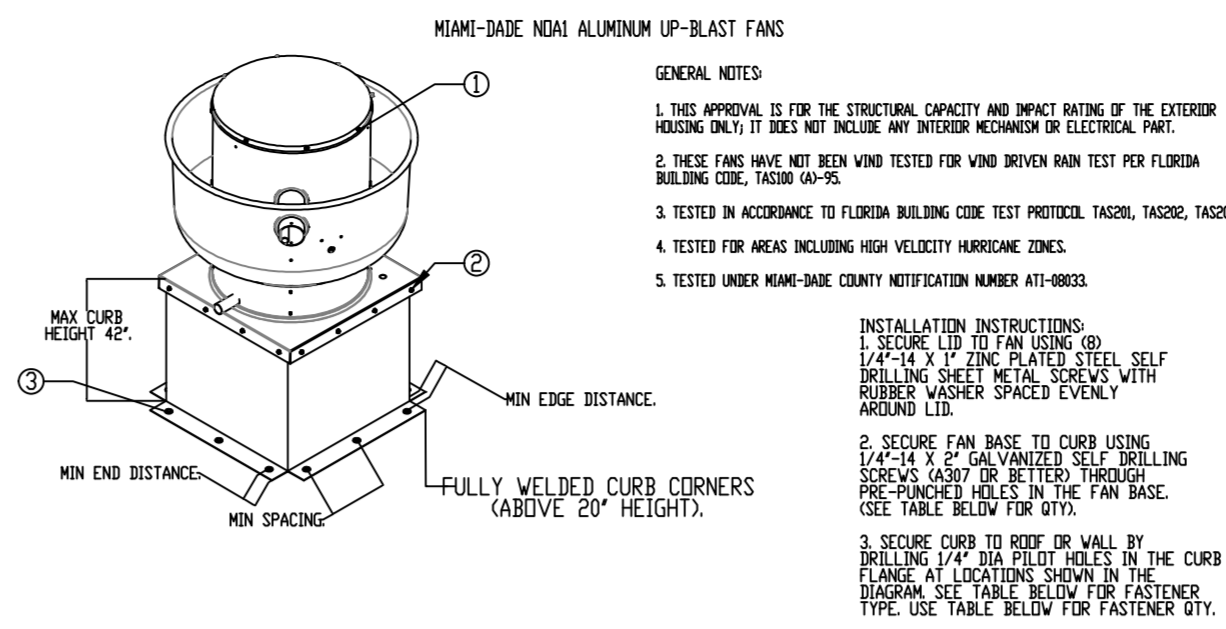

DESIGN PRESSURE: +150 / -150 PSF. LARGE MISSILE IMPACT RESISTANT.

INSTALLATION FASTENER TYPES			
FAN TO CURB	WOOD (SG = 0.42 MIN.)	STEEL (12 GAUGE MIN.)	CONCRETE (2500 PSI MIN. CRACKED CONCRETE)
FASTENER	5/16" X 2" SELF DRILLING SCREW (ELCO DRIL-FLEX OR BETTER)	3/8" DIA. ZINC PLATED LAG BOLT	1/4" X 14 DRIL-FLEX SELF DRILLING SCREW
MINIMUM THREAD PENETRATION	N/A	2-1/2"	12 GAUGE
MINIMUM EDGE DISTANCE	N/A	1-1/2"	3/8"
MINIMUM END DISTANCE	N/A	2-5/8"	3"
MINIMUM SPACING	N/A	1-1/2"	3/4"

INSTALLATION FASTENER QTY			
FAN MODEL	CURB TO FAN (WOOD)	STEEL	CONCRETE
	LONG SIDE	SHORT SIDE	TOTAL
DURS	3	12	9
	12	4	16
	4	16	5
	5	20	4
	16	4	16

MIAMI-DADE COUNTY - WALL CURB INSTALLATION GUIDE

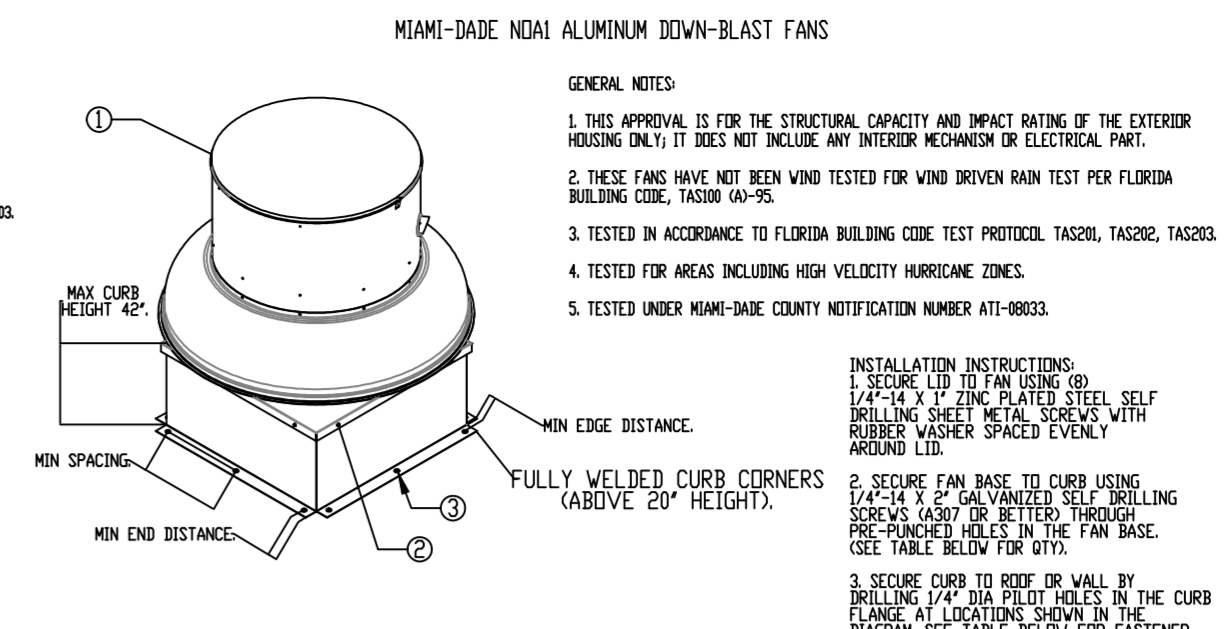
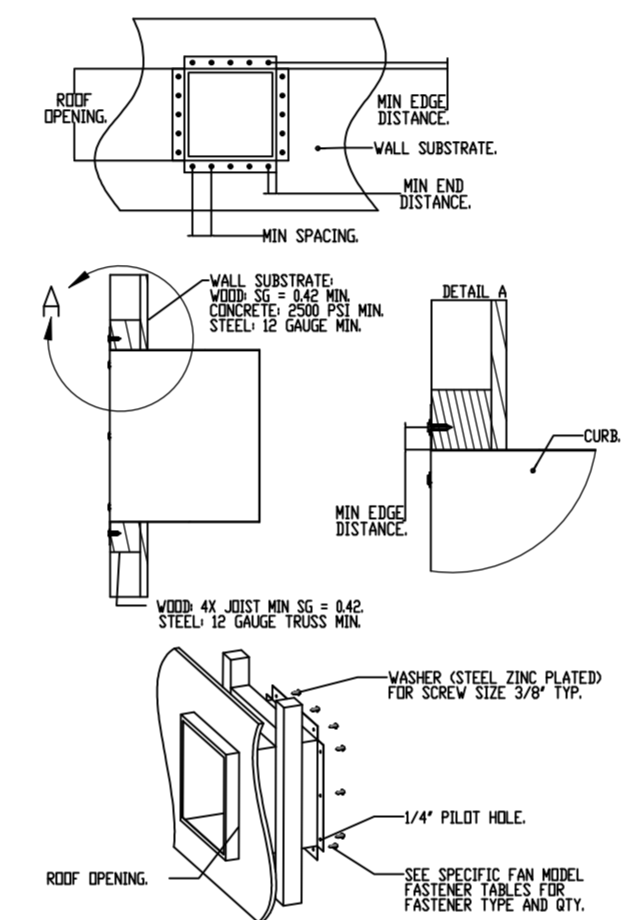

DESIGN PRESSURE: +150 / -150 PSF. LARGE MISSILE IMPACT RESISTANT.

INSTALLATION FASTENER TYPES			
FAN TO CURB	WOOD (SG = 0.42 MIN.)	STEEL (12 GAUGE MIN.)	CONCRETE (2500 PSI MIN. CRACKED CONCRETE)
FASTENER	5/16" X 2" SELF DRILLING SCREW (ELCO DRIL-FLEX OR BETTER)	3/8" DIA. ZINC PLATED LAG BOLT	1/4" X 14 DRIL-FLEX SELF DRILLING SCREW
MINIMUM THREAD PENETRATION	N/A	2-1/2"	12 GAUGE
MINIMUM EDGE DISTANCE	N/A	1-1/2"	3/8"
MINIMUM END DISTANCE	N/A	2-5/8"	3"
MINIMUM SPACING	N/A	1-1/2"	3/4"

INSTALLATION FASTENER QTY			
FAN MODEL	CURB TO FAN (WOOD)	STEEL	CONCRETE
	LONG SIDE	SHORT SIDE	TOTAL
SHR2	3	12	9
	12	4	16
	4	16	5
	5	20	4
	16	4	16

REVISIONS

DESCRIPTION	DATE

CAPTIVEAIRE

Highwoods Group

4641 Paragon Park Rd., Raleigh, NC, 27616 PHONE: (919) 875-0420 FAX: (919) 875-4577 EMAIL: reg100@captiveaire.com

CHIPOTLE LONGWOOD #4245

LONGWOOD, FL, 32779

DATE: 3/15/2022

DWG.#: 5379525

DRAWN BY: JMB-40

SCALE: 3/4" = 1'-0"

MASTER DRAWING

SHEET NO. 4

FANS #1 (EF-1), #2 (EF-2) - DUBSHFA EXHAUST FAN

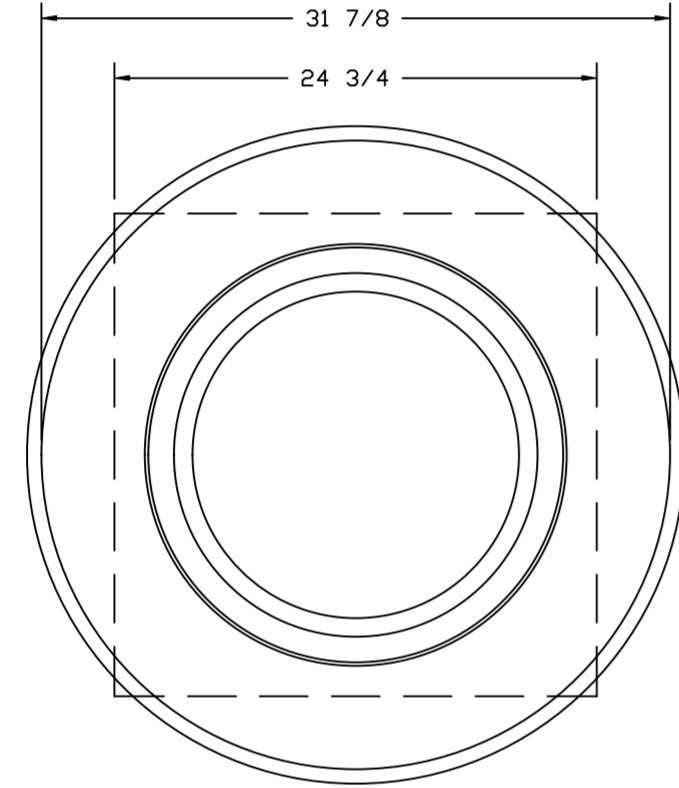
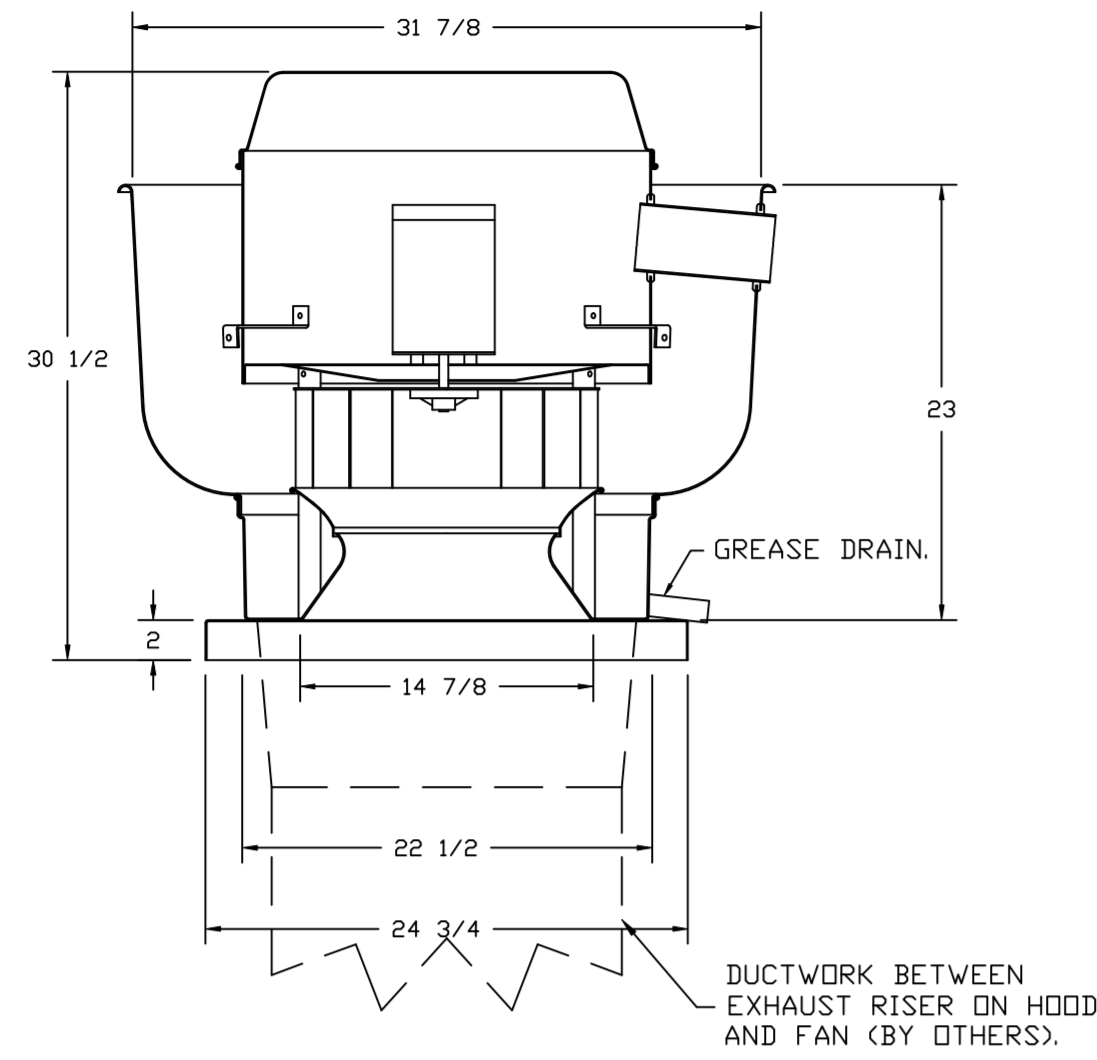

TOP VIEW

FEATURES:

- DIRECT DRIVE CONSTRUCTION (NO BELTS/PULLEYS).
- ROOF MOUNTED FANS.
- RESTAURANT MODEL.
- UL705 AND UL762 AND ULC-S645
- VARIABLE SPEED CONTROL.
- INTERNAL WIRING.
- THERMAL OVERLOAD PROTECTION (SINGLE PHASE).
- HIGH HEAT OPERATION 300°F (149°C).
- GREASE CLASSIFICATION TESTING.
- NEMA 3R SAFETY DISCONNECT SWITCH.

NORMAL TEMPERATURE TEST
EXHAUST FAN MUST OPERATE CONTINUOUSLY WHILE EXHAUSTING AIR AT 300°F (149°C) UNTIL ALL FAN PARTS HAVE REACHED THERMAL EQUILIBRIUM, AND WITHOUT ANY DETERIORATING EFFECTS TO THE FAN WHICH WOULD CAUSE UNSAFE OPERATION.

ABNORMAL FLARE-UP TEST
EXHAUST FAN MUST OPERATE CONTINUOUSLY WHILE EXHAUSTING BURNING GREASE VAPORS AT 600°F (316°C) FOR A PERIOD OF 15 MINUTES WITHOUT THE FAN BECOMING DAMAGED TO ANY EXTENT THAT COULD CAUSE AN UNSAFE CONDITION.

OPTIONS

- GREASE BOX.
- MIAMI DADE CERTIFICATION - NDA-1
- ALUMINUM UPBLAST.
- ECM WIRING PACKAGE - PWM SIGNAL FROM ECPM03 PREWIRE (TELCO MOTOR), CCW ROTATION.
- 2 YEAR PARTS WARRANTY.

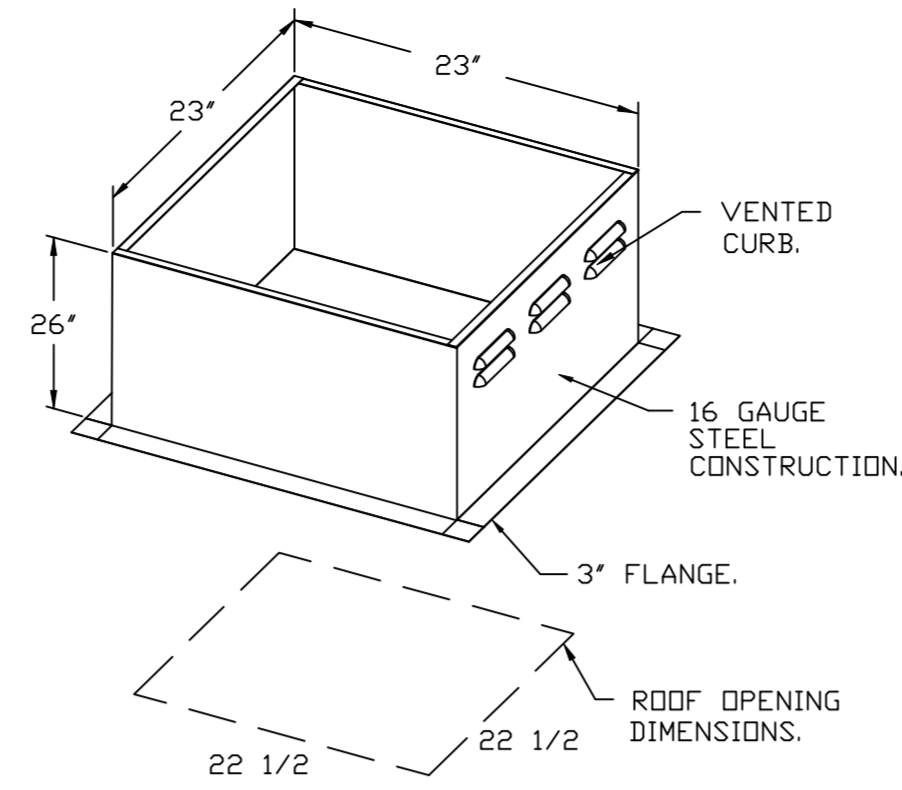

PITCHED CURBS ARE AVAILABLE FOR PITCHED ROOFS.

SPECIFY PITCH:
EXAMPLE: 7/12 PITCH = 30° SLOPE.

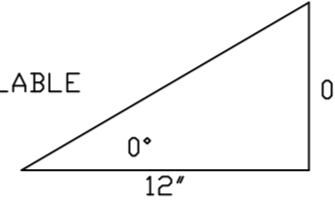

REVISIONS

DESCRIPTION	DATE:

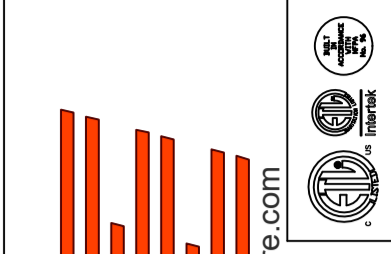

CAPTIVE

Highwoods Group

www.captiveair.com
www.highwoodsgroup.com

4641 Paragon Park Rd., Raleigh, NC, 27616 PHONE: (919) 875-0420 FAX: (919) 875-0577 EMAIL: reg10@captiveair.com

CHIPOTLE LONGWOOD #4245
LONGWOOD, FL, 32779

DATE: 3/15/2022

DWG.#:
5379525

DRAWN BY: JMB-40

SCALE:
3/4" = 1'-0"

MASTER DRAWING

SHEET NO.
5

FAN #3 DR12HFA - EXHAUST FAN (CF-2)

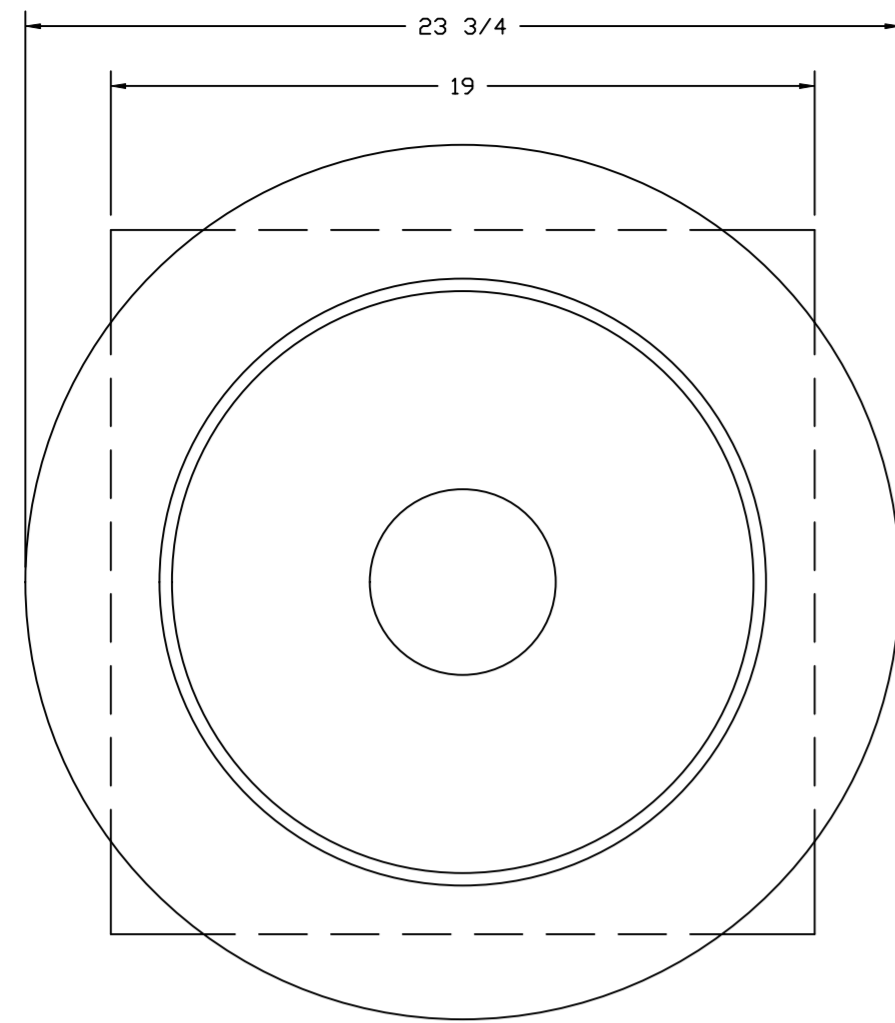

TOP VIEW

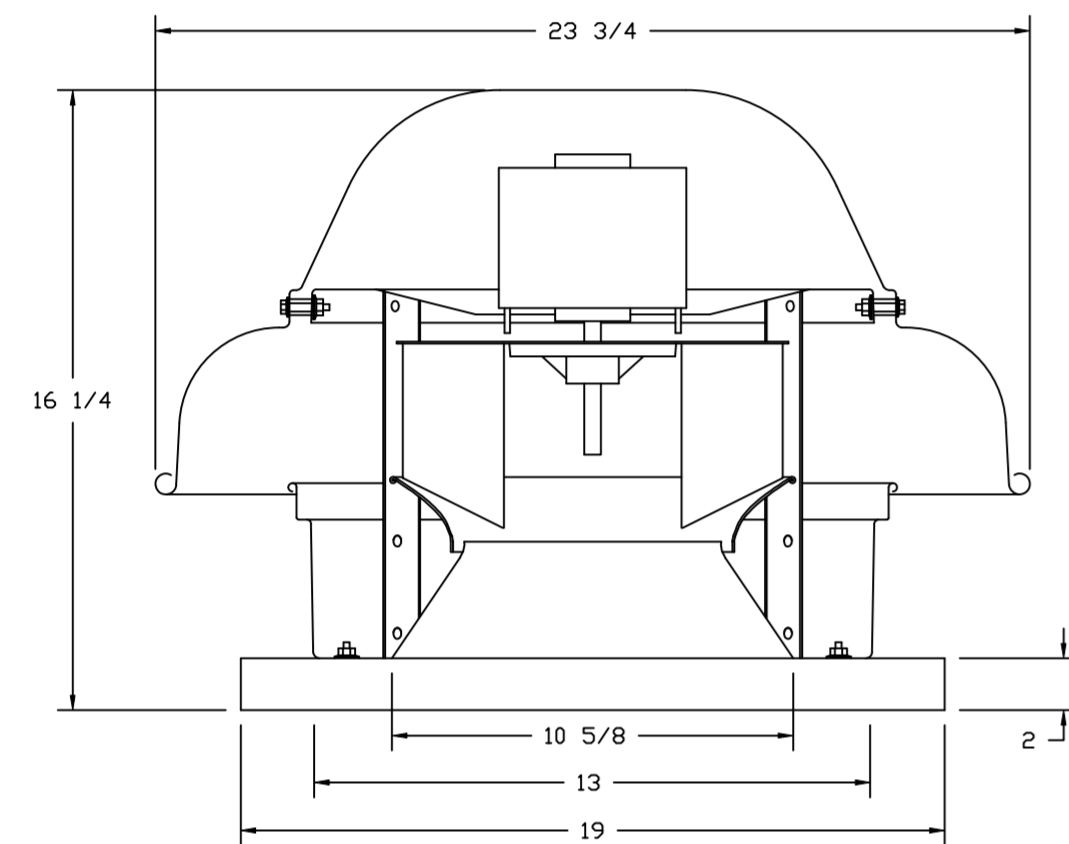

FEATURES:

- DIRECT DRIVE CONSTRUCTION (NO BELTS/PULLEYS).
- ROOF MOUNTED FANS.
- UL705.
- SAFETY DISCONNECT.
- STANDARD BIRD SCREEN.
- SPEED CONTROL.

OPTIONS:

- 1 12-BDD DAMPER.
- EDM WIRING PACKAGE - MANUAL OR 0-10VDC REFERENCE SPEED CONTROL (TELCO MOTOR, CCW ROTATION).
- MIAMI DADE CERTIFICATION - NDA-1.
- ALUMINUM DOWNBLAST 10.
- 2 YEAR PARTS WARRANTY.

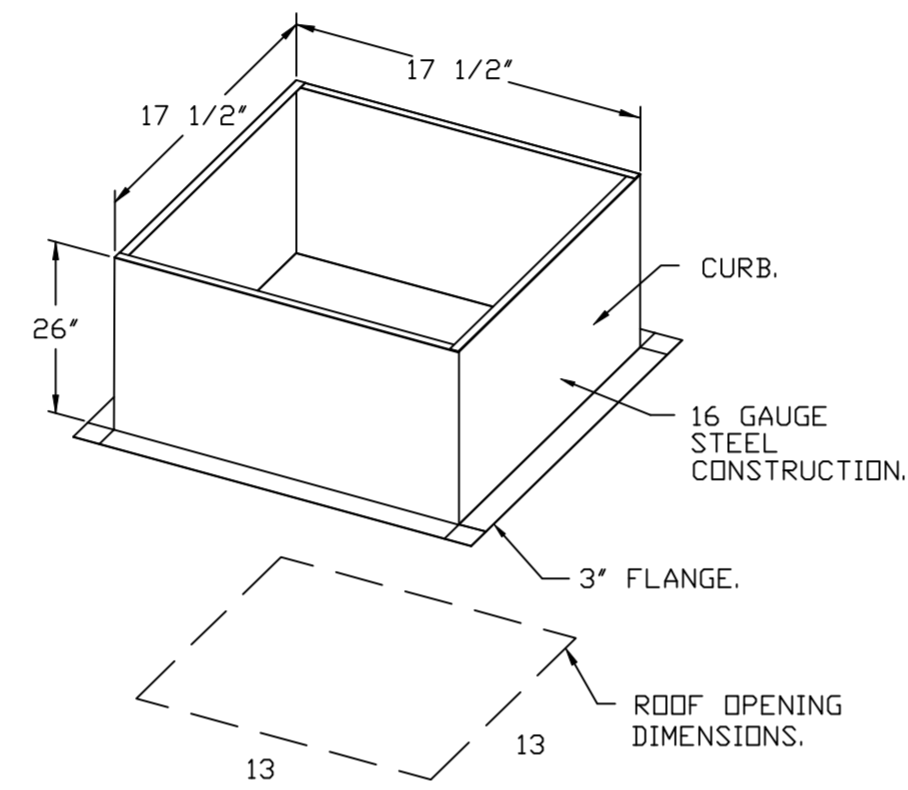

PITCHED CURBS ARE AVAILABLE FOR PITCHED ROOFS.
 SPECIFY PITCH:
 EXAMPLE: 7/12 PITCH = 30° SLOPE.

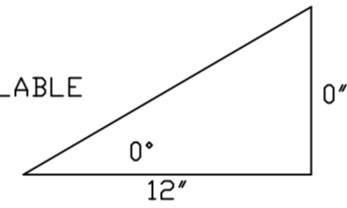

BACKDRAFT DAMPER INSTALLATION

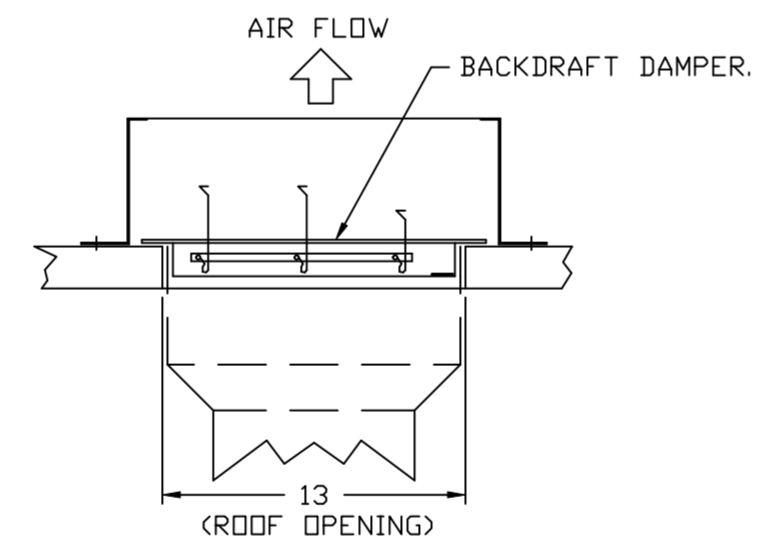

REVISIONS

DESCRIPTION	DATE

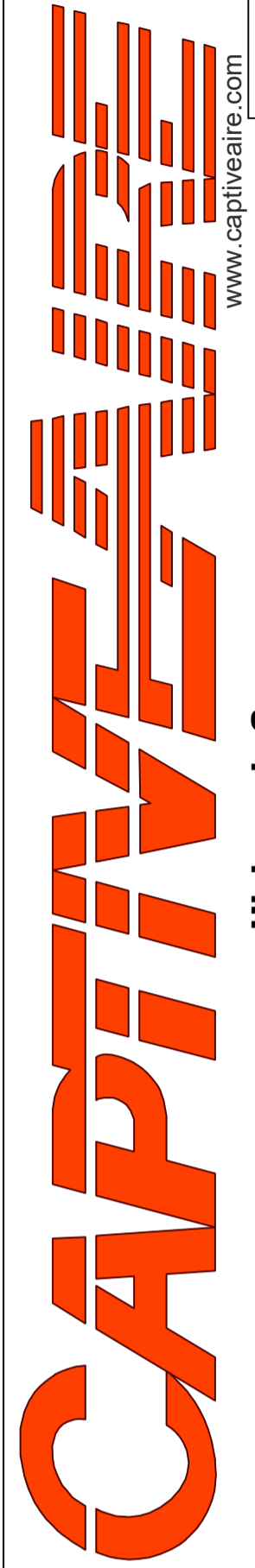
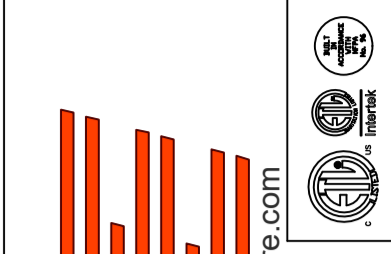

www.captive.com

Highwoods Group
 4641 Paragon Park Rd., Raleigh, NC, 27616 PHONE: (919) 875-0420 FAX: (919) 875-4577 EMAIL: reg40@captive.com

CHIPOTLE LONGWOOD #4245
 LONGWOOD, FL, 32779

DATE: 3/15/2022

DWG.#: 5379525

DRAWN BY: JMB-40

SCALE: 3/4" = 1'-0"

MASTER DRAWING

SHEET NO. 6

- FAN #4 AI-D250-1SD - HEATER (MAU-1)
1. DIRECT GAS FIRED HEATED MAKE UP AIR UNIT WITH 15' MIXED FLOW DIRECT DRIVE FAN.
 2. INTAKE HOOD WITH EZ FILTERS.
 3. DOWN DISCHARGE - AIR FLOW RIGHT -> LEFT.
 4. MOTORIZED BACK DRAFT DAMPER 16" X 18" FOR SIZE 1 STANDARD & MODULAR HEATER UNITS W/EXTENDED SHAFT, STANDARD GALVANIZED CONSTRUCTION, 3/4" REAR FLANGE, LOW LEAKAGE, TFB20S ACTUATOR INCLUDED.
 5. LOW FIRE START. ALLOWS THE BURNER CIRCUIT TO ENERGIZE WHEN THE MODULATION CONTROL IS IN A LOW FIRE POSITION.
 6. GAS PRESSURE GAUGE, 0-35", 2.5" DIAMETER, 1/4" THREAD SIZE.
 7. GAS PRESSURE GAUGE, -5 TO +15 INCHES WC., 2.5" DIAMETER, 1/4" THREAD SIZE.
 8. DOWN DISCHARGE CONSTRUCTION FOR SIZE 1 DIRECT DRIVE AHUS.
 9. MIAMI DADE IMPACT AND WIND LOAD CERTIFICATION +30 / -130 PSF - MIAMI DADE COUNTY PRODUCT CONTROL APPROVED. FLORIDA BUILDING CODE APPROVAL. ROOF MOUNT EXHAUST CURBS UP TO 20" HIGH MUST BE 16 GAUGE ALUMINIZED.
 10. SEPARATE 120VAC WIRING PACKAGE FOR MAKE-UP AIR UNITS. OPTION MUST BE SELECTED WHEN MOUNTING VFD IN PREWIRE PANEL OR WITH DCV PACKAGE. PROVIDES SEPARATE 120VAC INPUT TO SUPPLY FAN. THIS 120V SIGNAL MUST BE RUN BY ELECTRICIAN FROM DCV TO MUA SWITCH.
 11. UNIT MOUNTED VFD FOR USE WITH ECPM03.
 12. HINGED DOUBLE WALL INSULATED DOOR ASSEMBLY (BURNER/BLOWER SECTION).
 13. 2 YEAR PARTS WARRANTY.

*NOTE: SUPPLY DUCT MUST BE INSTALLED TO MEET SMACNA STANDARDS. A MINIMUM STRAIGHT DUCT LENGTH MUST BE MAINTAINED DOWNSTREAM OF UNIT DISCHARGE AS OUTLINED IN AMCA PUBLICATION 201. WHEN USING RECTANGULAR DUCTWORK, ELBOWS MUST BE RADIUS THROAT, RADIUS BACK WITH TURNING VANES. FLEXIBLE DUCTWORK AND SQUARE THROAT/SQUARE BACK ELBOWS SHOULD NOT BE USED. ANY TRANSITION AND/OR TURNS IN THE DUCTWORK WILL CAUSE SYSTEM EFFECT. SYSTEM EFFECT WILL DRASTICALLY INCREASE STATIC PRESSURE AND REDUCE AIRFLOW. DO NOT RELY ON UNIT TO SUPPORT DUCT IN ANY WAY. FAILURE TO PROPERLY SIZE DUCTWORK MAY CAUSE SYSTEM EFFECTS AND REDUCE PERFORMANCE OF THE EQUIPMENT. SUGGESTED STRAIGHT DUCT SIZE IS 14" X 14".

SUPPLY SIDE HEATER INFORMATION:

WINTER TEMPERATURE = 42°F. TEMP. RISE = 33°F.
 BTUs CALCULATED OFF ACTUAL AIR DENSITY.
 OUTPUT BTUs AT ALTITUDE OF 0.0 FT. = 68748.
 INPUT BTUs AT ALTITUDE OF 0.0 FT. = 74726.
 OUTPUT BTUs AT ALTITUDE OF 58 FT. = 68604.
 INPUT BTUs AT ALTITUDE OF 58 FT. = 74569.

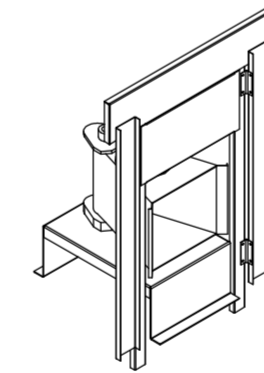
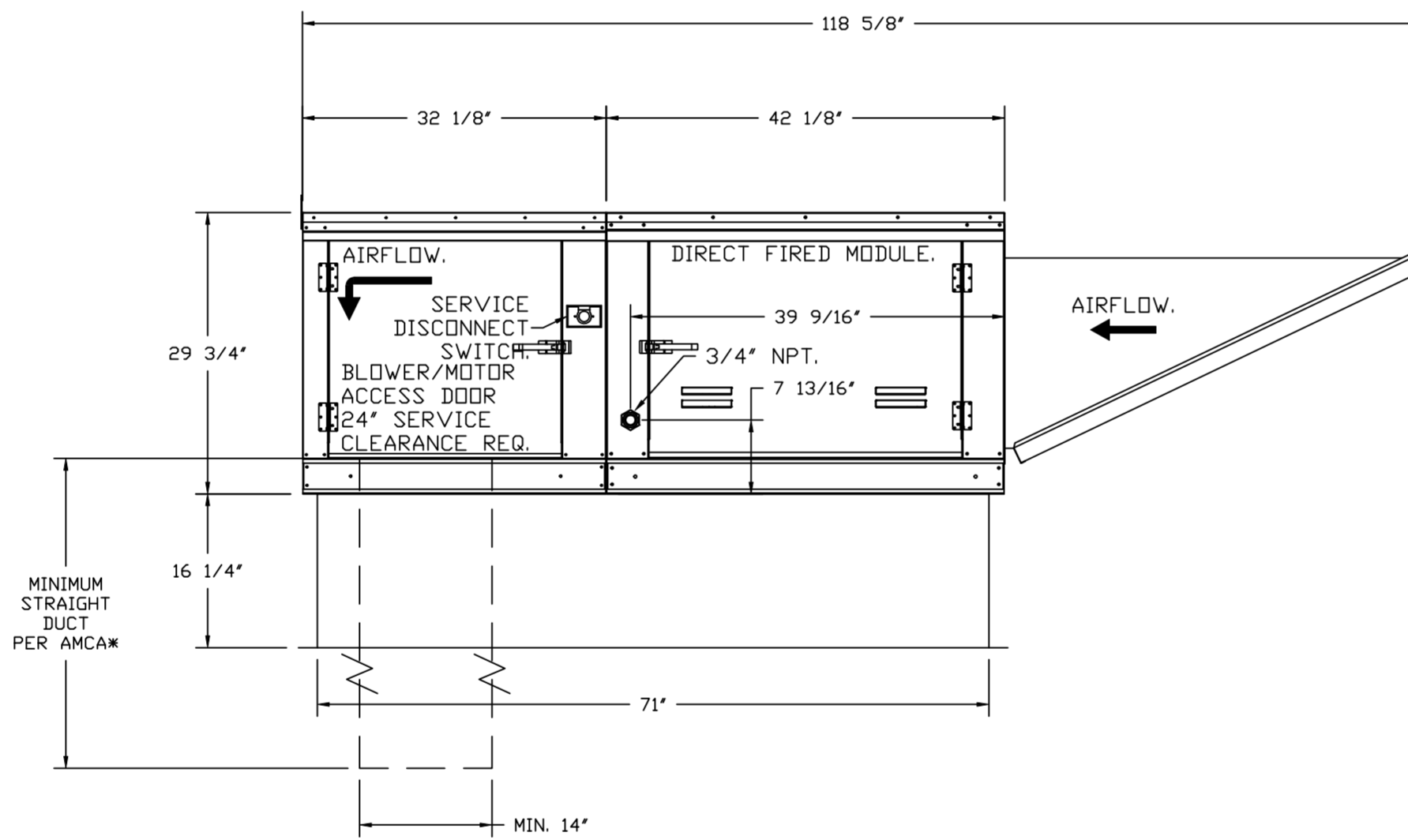
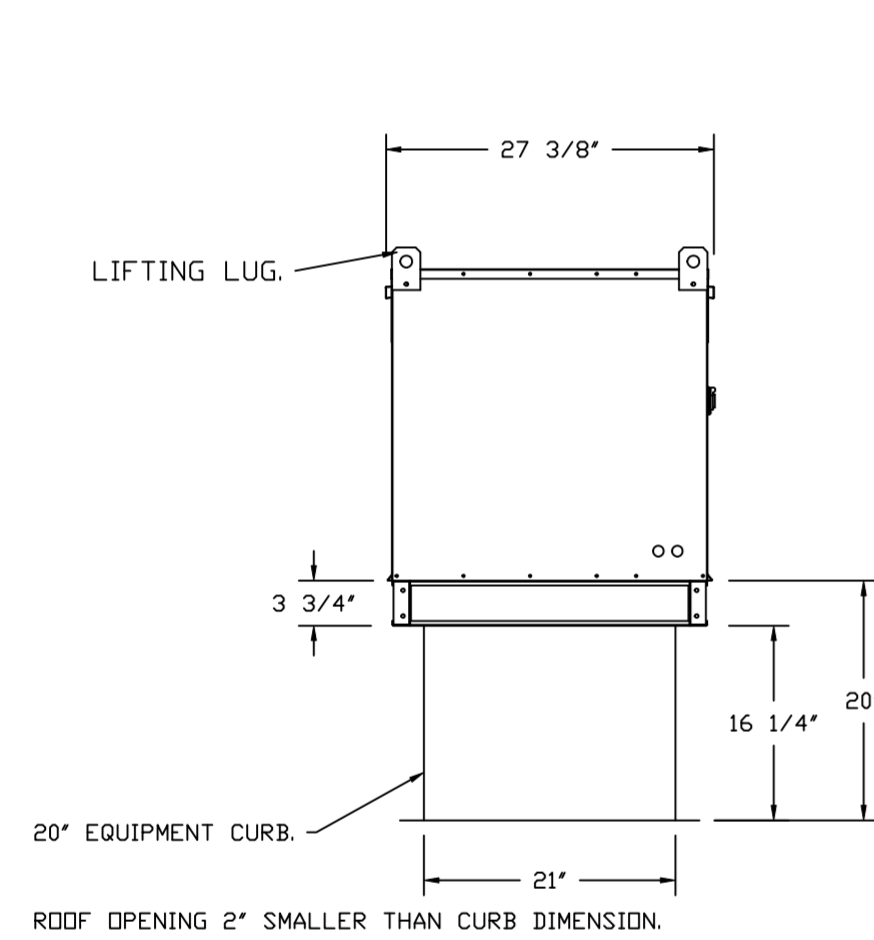
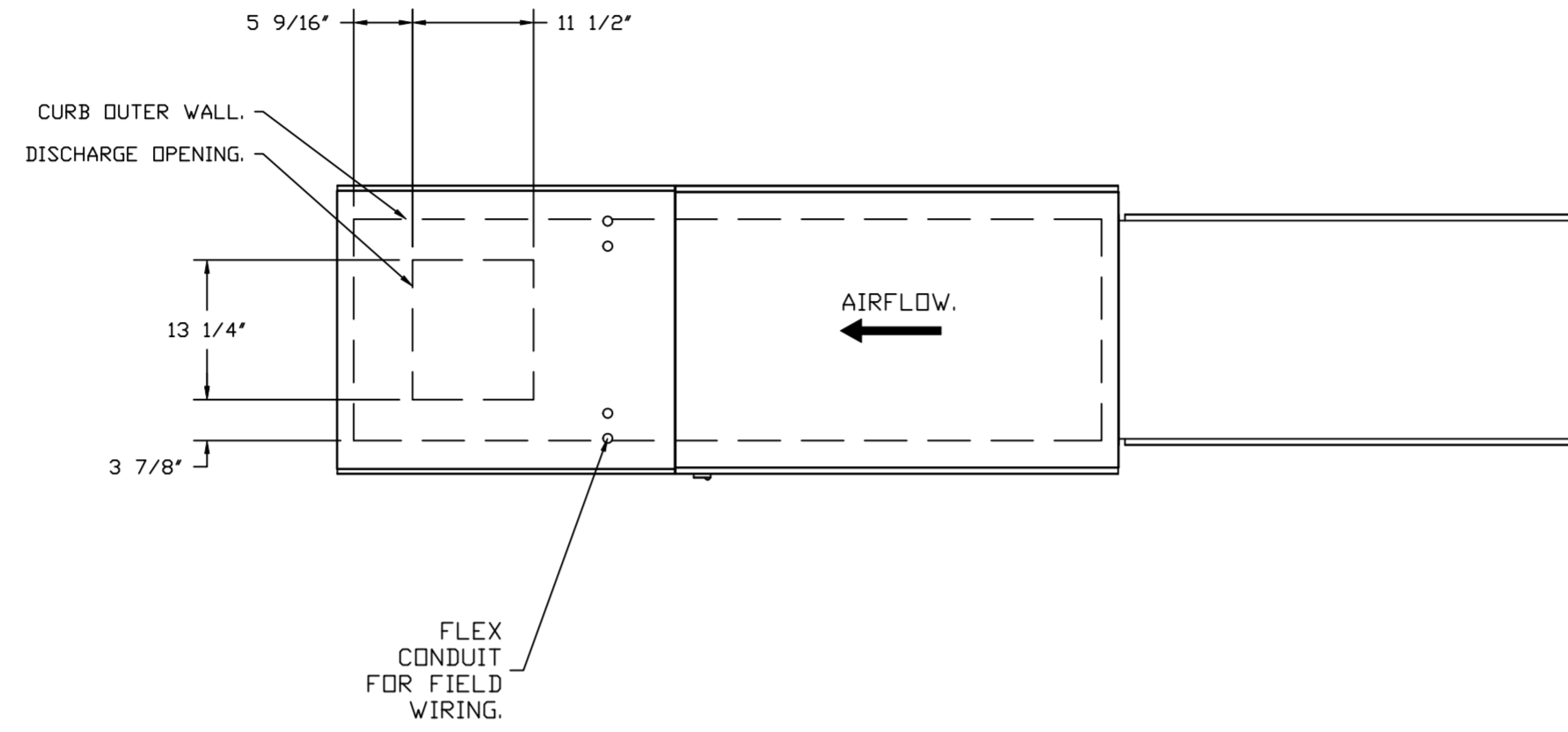

DIRECT FIRED (DF) PROFILE PLATE ASSEMBLY

DIRECT FIRED PROFILE PLATE SPECIFICATIONS:

DESCRIPTION:
 DIRECT FIRED BURNERS SHALL HAVE PATENTED (US PATENT NO. US6695238D), SELF-ADJUSTING PROFILE PLATES DESIGNED TO ENSURE PROPER AIR VELOCITY AND PRESSURE DROP ACROSS THE BURNER. PROFILE PLATES SHALL ALLOW BURNERS TO ACHIEVE CLEAN COMBUSTION BY LIMITING BY-PRODUCT LEVELS TO A MAXIMUM OF 50PPM OF CARBON MONOXIDE (CO), AND 0.50PPM OF NITROGEN DIOXIDE (NO2). DIRECT FIRED UNITS SHALL BE CONFIGURED WITH THE BLOWER MOUNTED DOWNSTREAM OF THE BURNER. THIS ARRANGEMENT WILL ENSURE A CONSISTENT AIRFLOW, REGARDLESS OF INLET AIR TEMPERATURE.

APPLICATION:
 SPRING-LOADED BURNER PROFILE PLATES ARE ENGINEERED TO AUTOMATICALLY REACT TO THE MOMENTUM OF A FRESH AIR STREAM, WITHOUT THE NEED FOR ANY MOTORS OR ACTUATORS TO MECHANICALLY ADJUST THEM. WITH THIS FEATURE, ALL DF UNITS ARE DESIGNED FOR DEMAND CONTROL VENTILATION (DCV) REQUIREMENTS.

CERTIFICATIONS:
 ALL PROFILE PLATE ASSEMBLIES SHALL BE INCLUDED IN THE DF UNIT'S ETL LISTING AND COMPLY WITH COMBINED SAFETY STANDARDS ANSI Z83.4 AND CSA 3.7 (NON-RECIRCULATING DF HEATERS) AND ANSI Z83.18 (RECIRCULATING DF HEATERS).

GENERAL CONSTRUCTION:
 -PROFILE PLATES SHALL BE FORMED FROM G90 GALVANIZED STEEL.
 -PROFILE PLATES SHALL VARY IN SIZE PER UNIT.
 -PROFILE PLATES SHALL BE MOUNTED ALONG THE SAME PLANE AS THE DISCHARGE OF THE BURNER.
 -DESIGN SHALL INCORPORATE PROPERLY TORQUED, PERMANENTLY MOUNTED SPRING HINGES.
 -SPRING HINGES SHALL BE MADE FROM PLATED STEEL.

REVISIONS	
DESCRIPTION	DATE

www.captiveair.com
 Highwoods Group
 4641 Paragon Park Rd., Raleigh, NC, 27616 PHONE: (919) 875-0420 FAX: (919) 875-0577 EMAIL: reg10@captiveair.com

CHIPOTLE LONGWOOD #4245
 LONGWOOD, FL, 32779

DATE: 3/15/2022

DWG.#:
 5379525

DRAWN BY: JMB-40

SCALE:
 3/4" = 1'-0"

MASTER DRAWING

SHEET NO.
 7

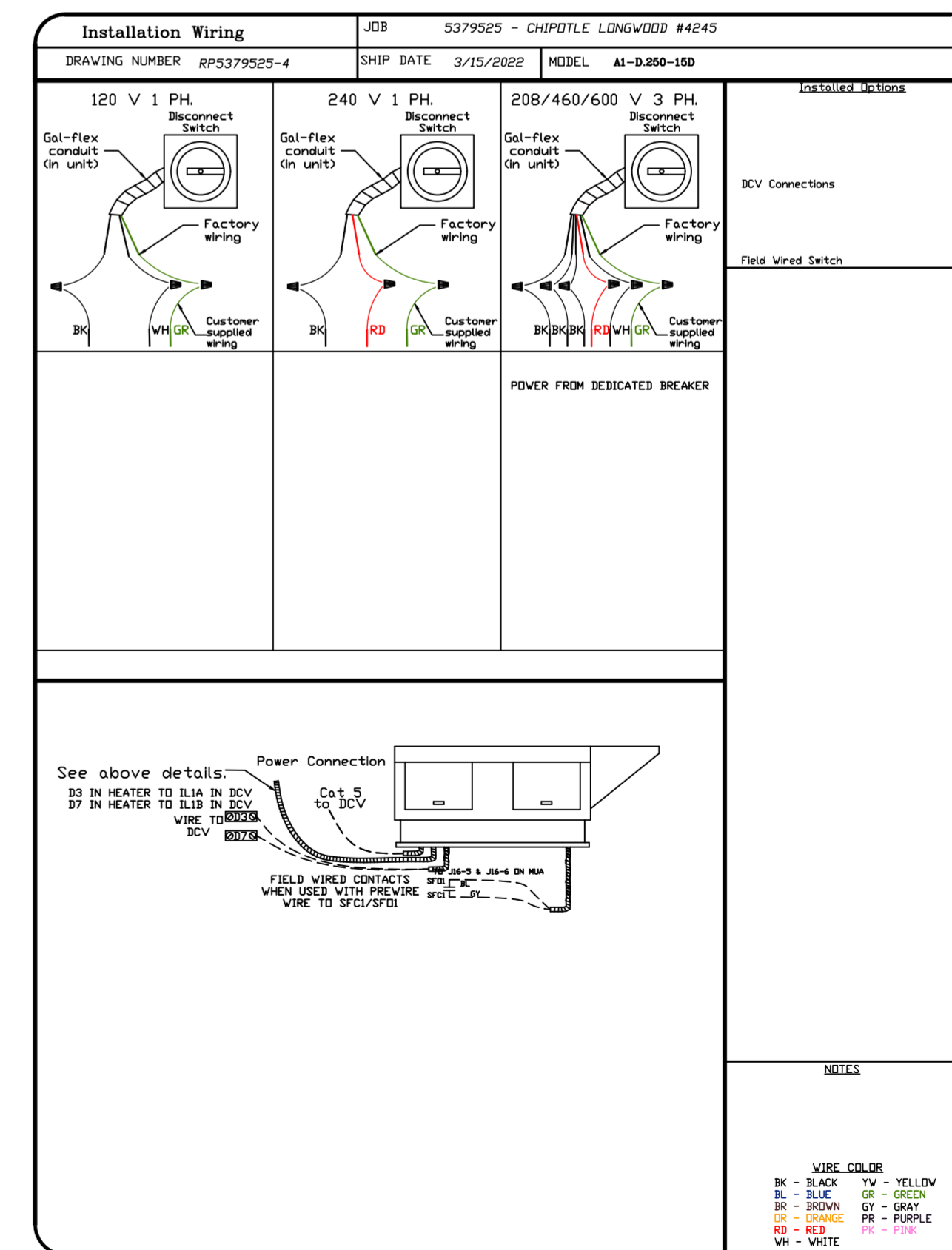
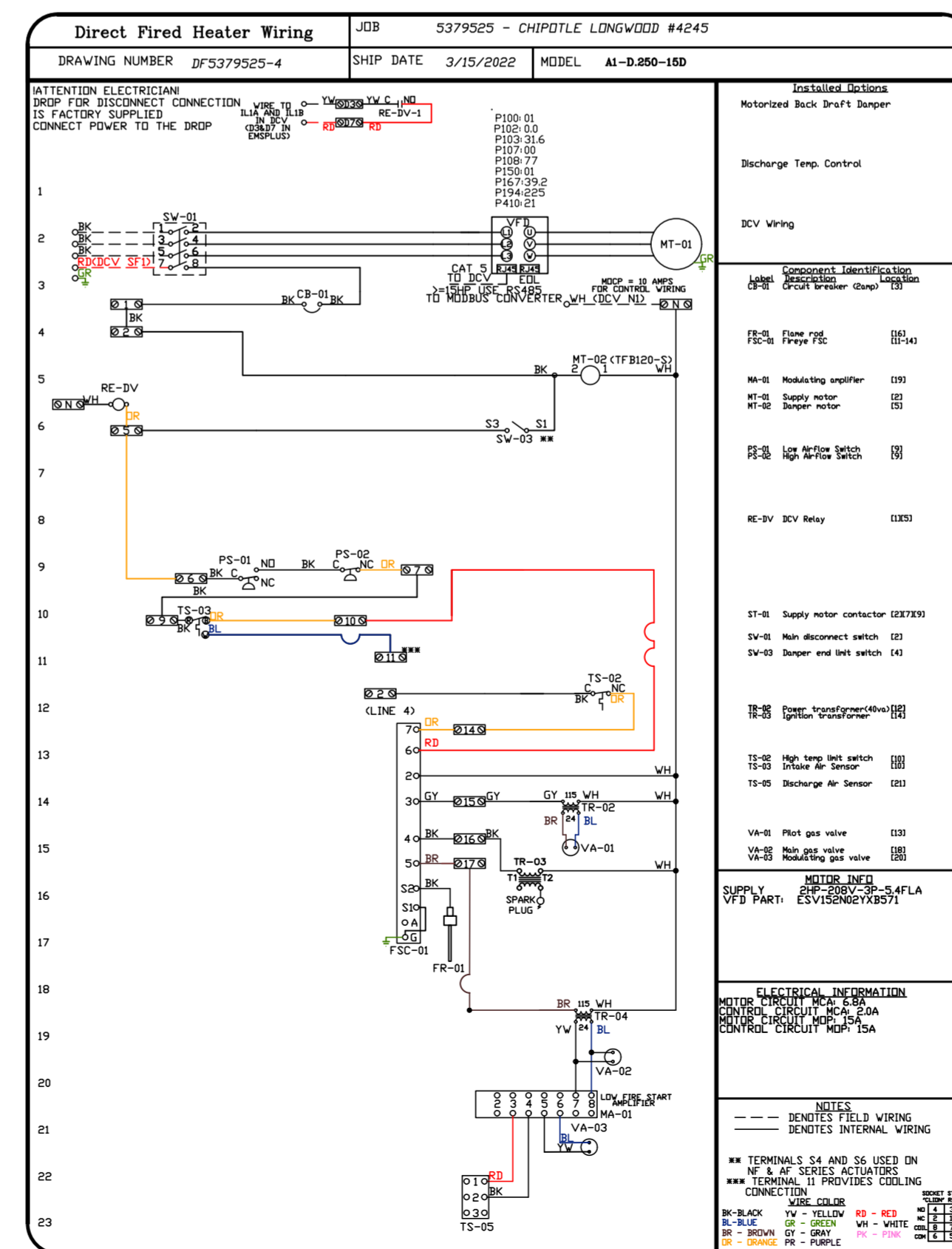
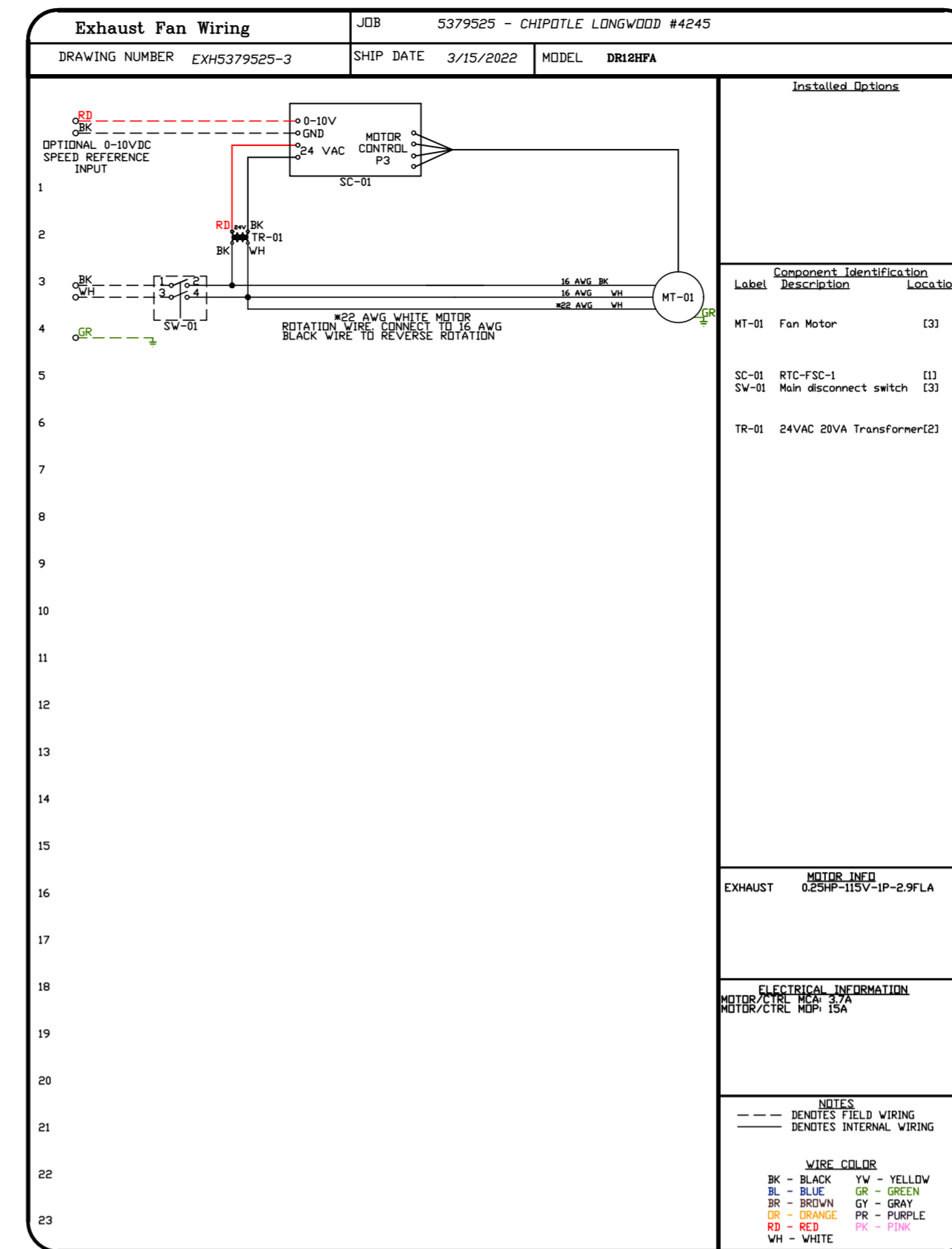
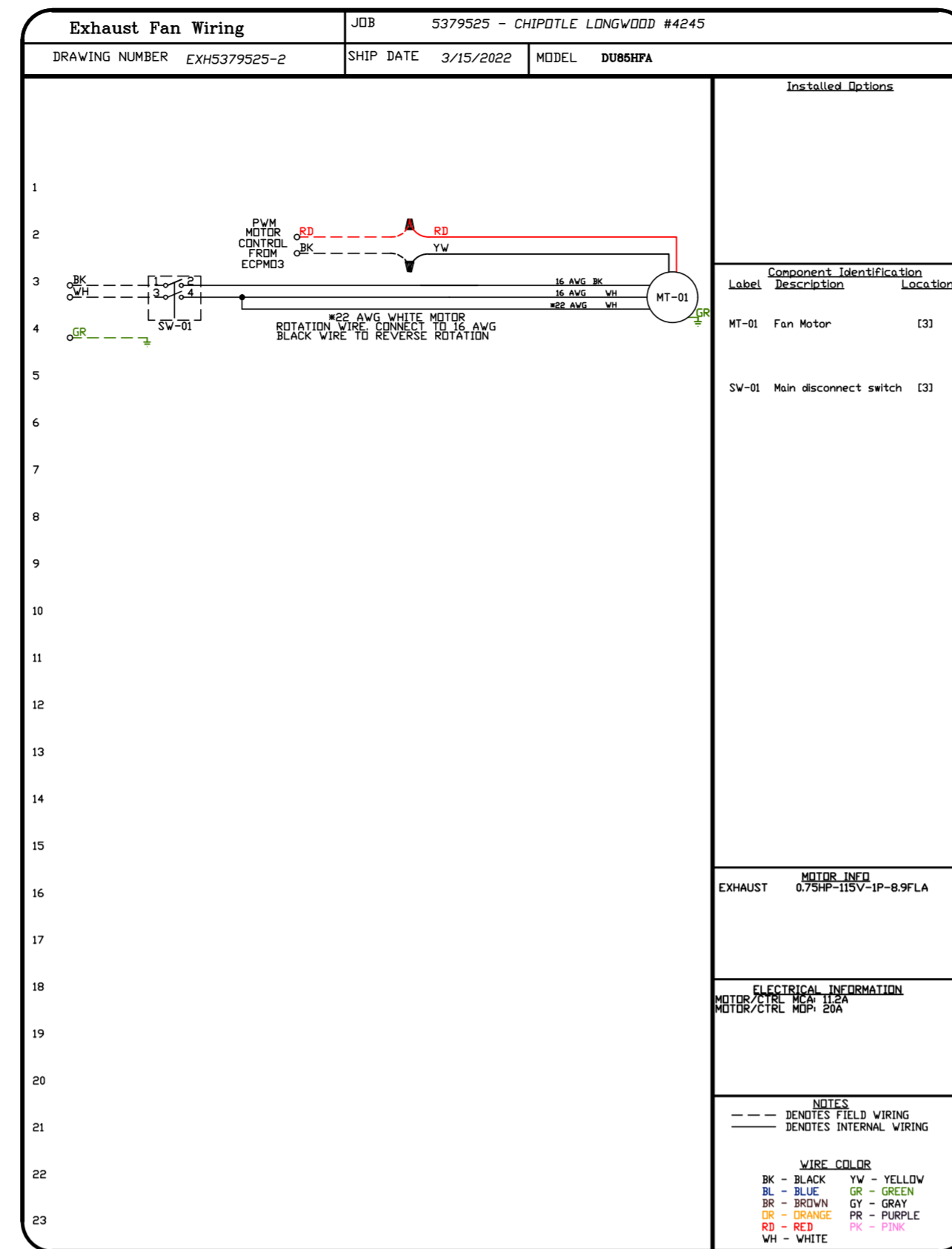
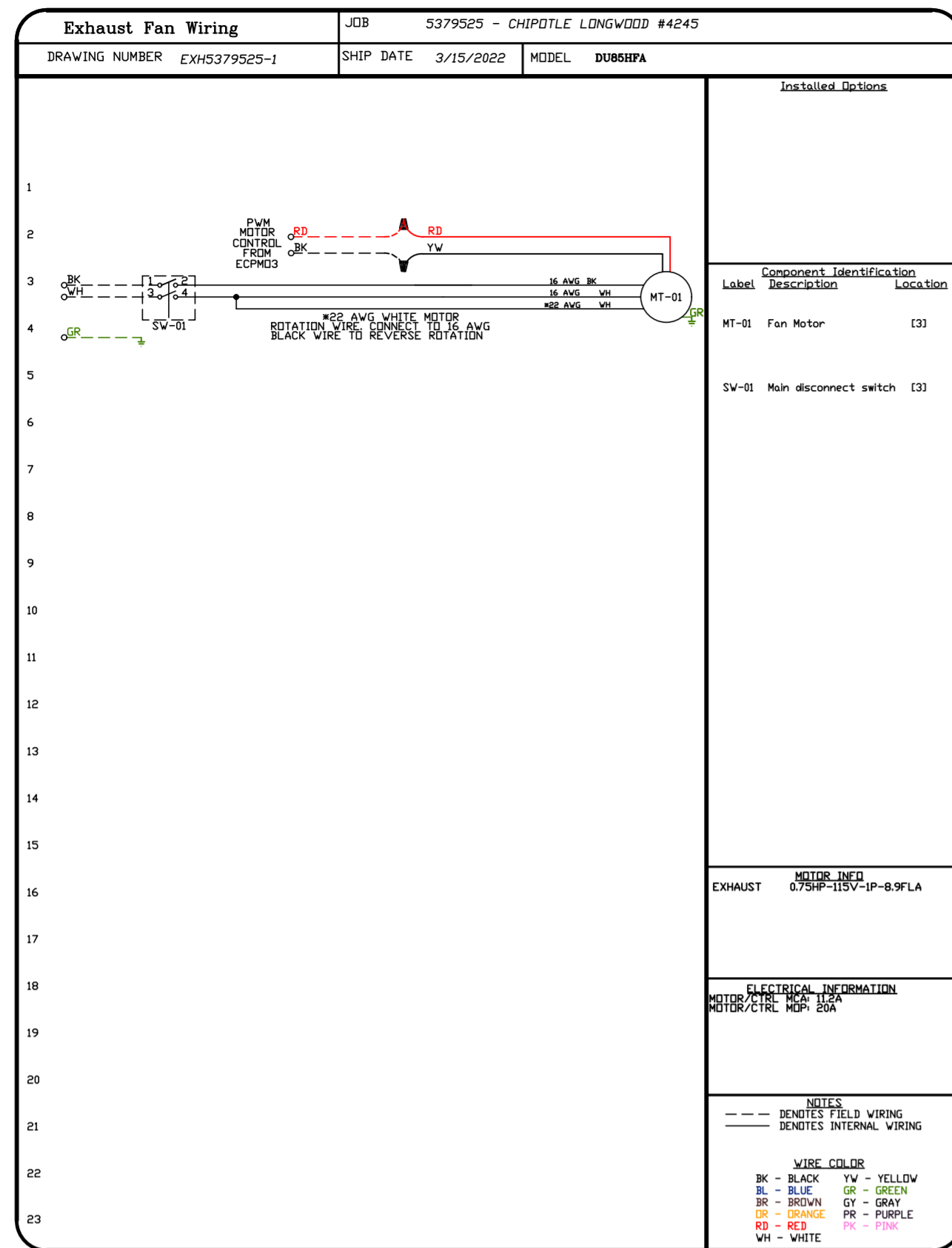

REVISIONS	
DESCRIPTION	DATE

Highwoods Group

www.captive.com

4641 Paragon Park Rd., Raleigh, NC 27616 PHONE: (919) 875-0420 FAX: (919) 875-0577 EMAIL: reg100@captive.com

CHIPOTLE LONGWOOD #4245
 LONGWOOD, FL, 32779

DATE: 3/15/2022
 DWG.#: 5379525
 DRAWN BY: JMB-40
 SCALE: 3/4" = 1'-0"
 MASTER DRAWING

SHEET NO.
 8

ELECTRICAL PACKAGE - JOB#5379525

NO	TAG	PACKAGE #	LOCATION	SWITCHES		OPTION	FANS CONTROLLED					
				LOCATION	QUANTITY		FAN TAG	TYPE	#	HP	VOLT	FLA
1		SC-321110MA	UTILITY CABINET RIGHT	04 - UTILITY CABINET RIGHT	1 LIGHT	SMART CONTROLS THERMOSTATIC CONTROL V/ RELAY ON/OFF WITH SUPPLY	EF-1	EXHAUST	1	0.750	115	8.9
				HOOD # 1	1 FAN		MAU-1	SUPPLY	3	2.000	208	5.4

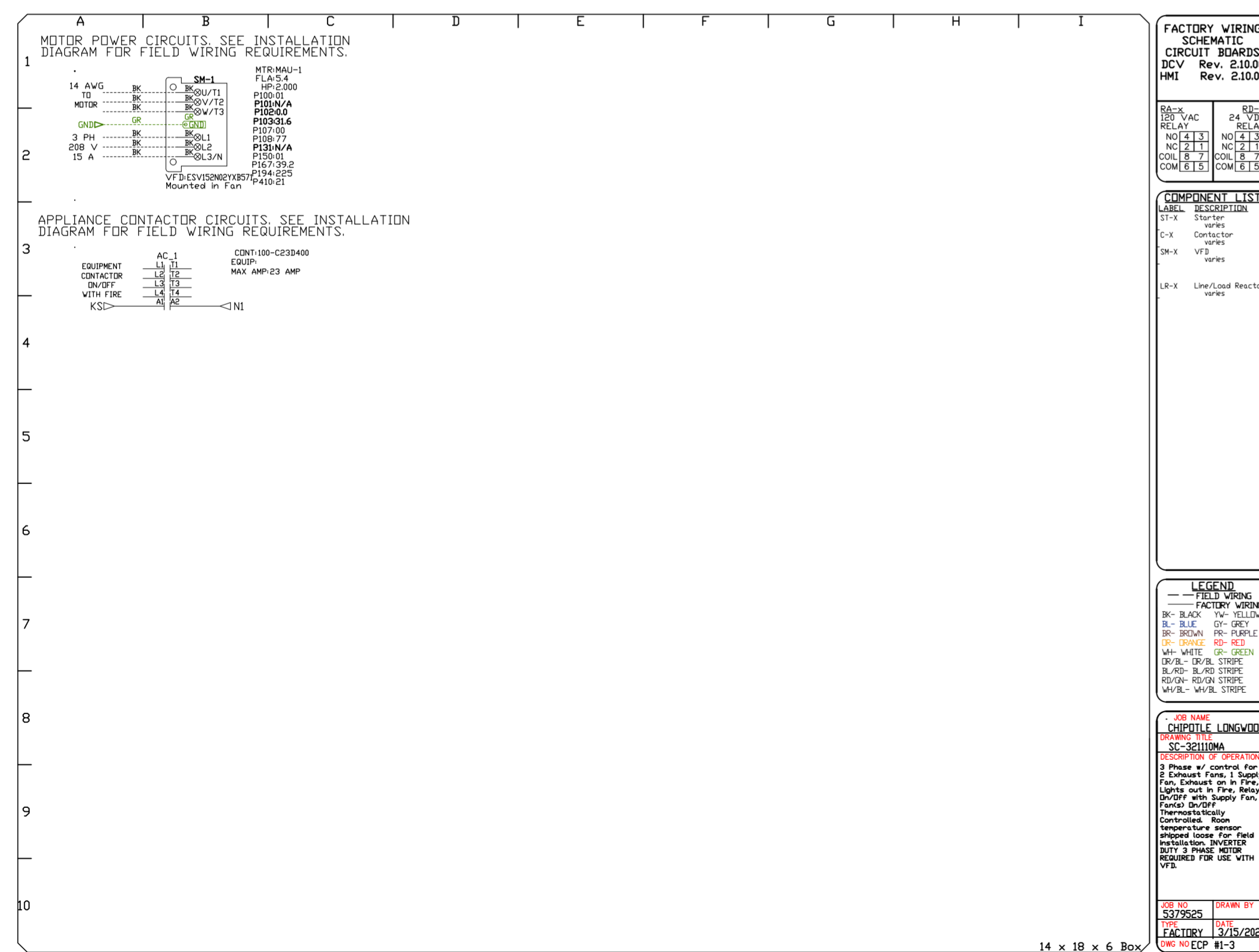
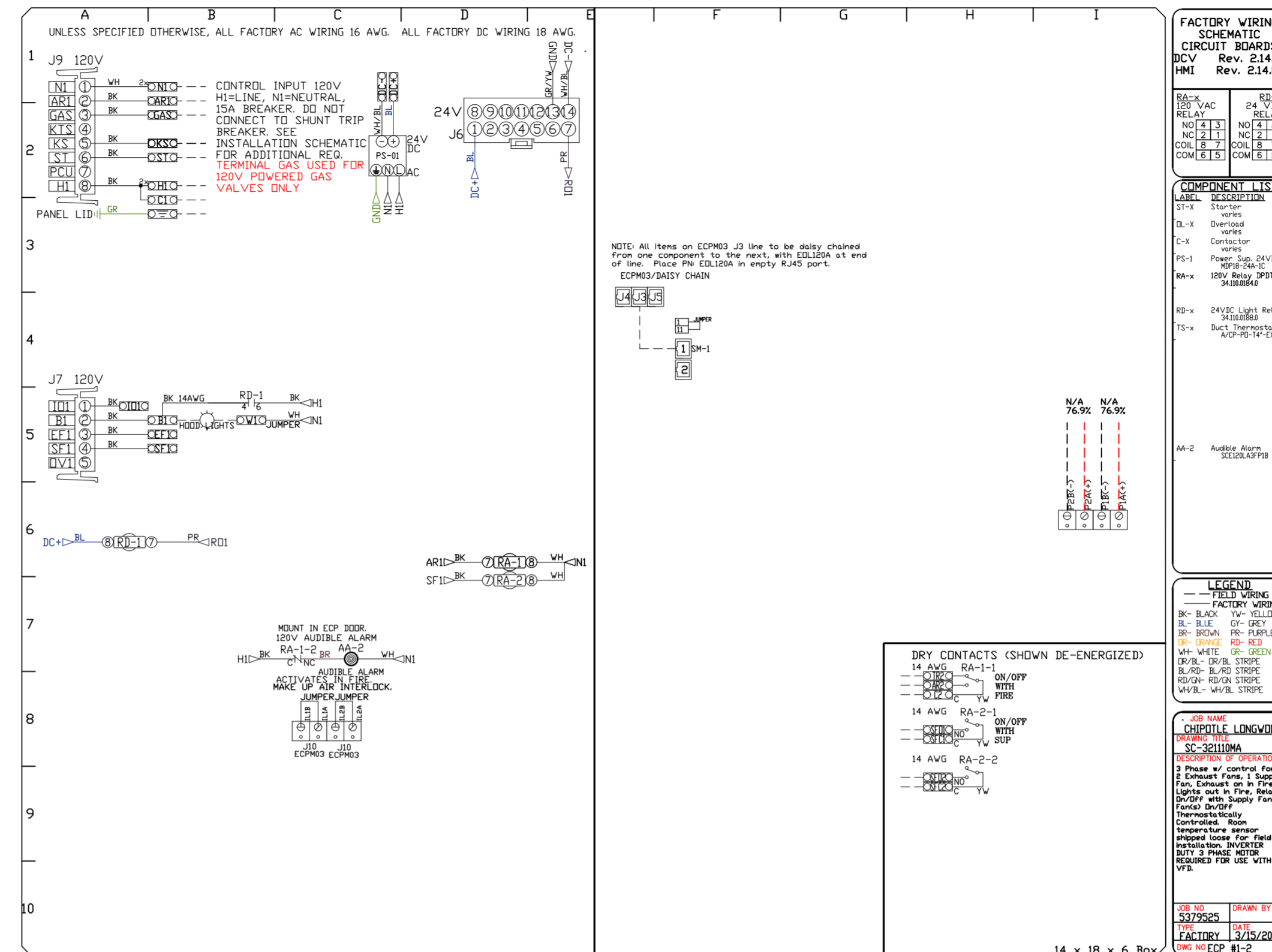
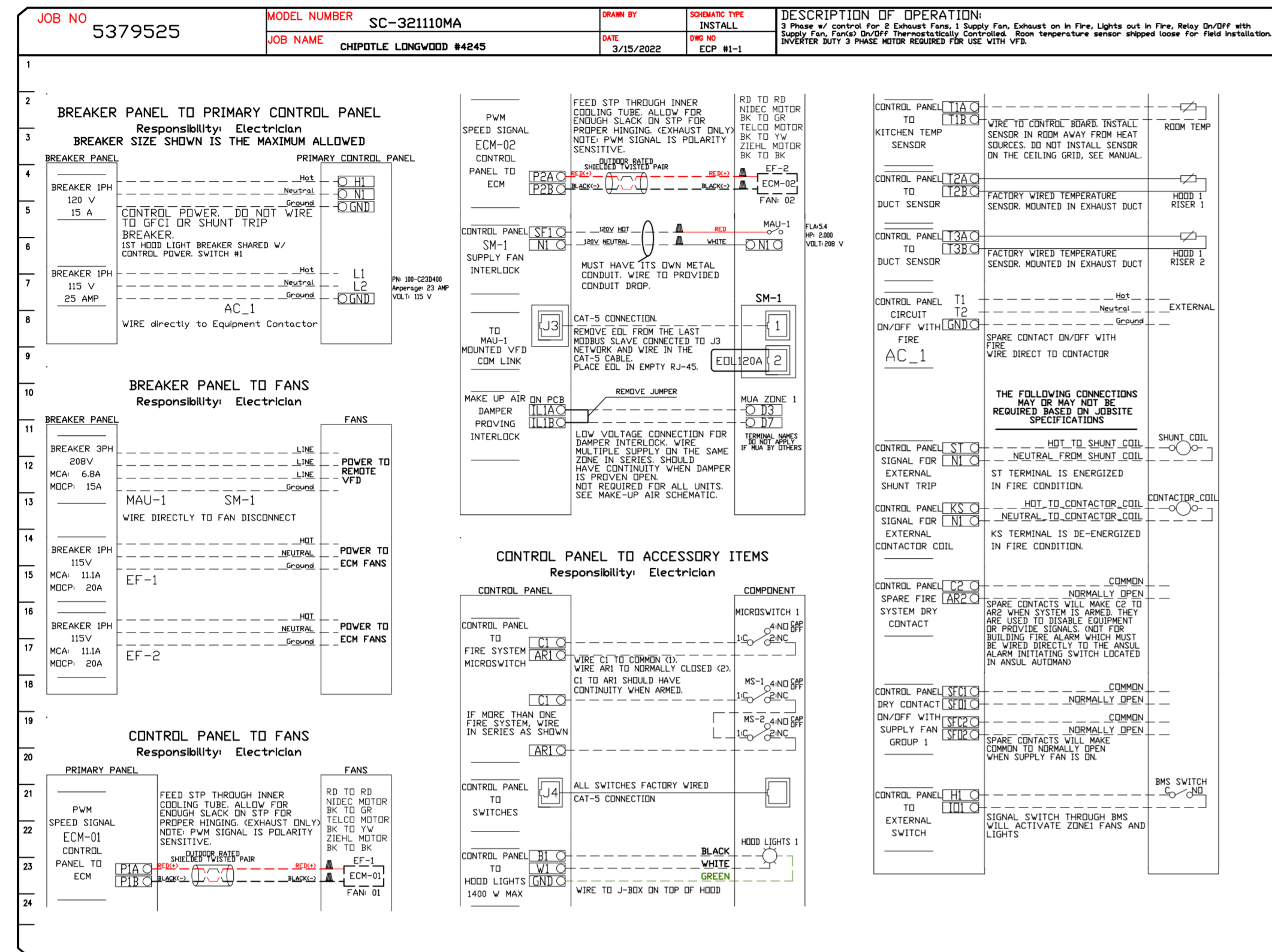

REVISIONS

NO.	DESCRIPTION	DATE
1		
2		
3		
4		

CHIPOTLE LONGWOOD #4245
LONGWOOD, FL, 32779

DATE: 3/15/2022
DWG.#: 5379525
DRAWN BY: JMB-40
SCALE: 3/4" = 1'-0"
MASTER DRAWING

SHEET NO.
 9

CAPTIVE
 Highwoods Group
 www.captive.com
 4641 Paragon Park Rd., Raleigh, NC, 27616 PHONE: (919) 875-0420 FAX: (919) 875-0577 EMAIL: reg100@captive.com