

NOTES

- REFER TO "PART 2 CONTROLS" OF THE MECHANICAL SPECIFICATIONS FOR DIFFERENTIATION BETWEEN CONTROL AND POWER WIRING RESPONSIBILITIES.
- ANY CONTACTORS OR WIRING REQUIRED FOR SHUT-OFF OF ELECTRIC COOKING EQUIPMENT SHALL BE FURNISHED BY ELECTRICAL CONTRACTOR.
- ALL ROOF CURBS SHALL BE SHIMMED LEVEL.
- ROOF CURBS FOR EXHAUST SYSTEMS SHALL BE INSTALLED IN ACCORDANCE WITH THE "NATIONAL ROOFING CONTRACTORS ASSOCIATION" GUIDELINES, AND THE ROOFING SUPPLIER'S DETAILS AND GUIDELINES FOR THE SPECIFIC ROOFING MATERIALS USED. ALL CURB INSULATION SHALL BE SUPPLIED AND INSTALLED BY ROOFING CONTRACTOR.
- THE GENERAL CONTRACTOR SHALL PROVIDE ALL ROOFCUT OPENINGS AND OTHER STRUCTURAL REQUIREMENTS FOR THE INSTALLATION OF ALL ROOF EQUIPMENT. REFER TO STRUCTURAL FRAMING PLAN FOR EQUIPMENT LOCATION DIMENSIONS.
- ANSUL FIRE EXTINGUISHING SYSTEM SHALL BE INSTALLED IN ACCORDANCE WITH HOOD MFR'S SHOP DRAWINGS. SEE SHOP DRAWINGS FOR RESPONSIBILITIES OF MECHANICAL CONTRACTOR.
- FIRE SUPPRESSION SYSTEM SHALL CONSIST OF A COMPLETE WET ANSUL SYSTEM FOR HOODS #1 & #2 AND SHALL BE FURNISHED BY THE HOOD MANUFACTURER. COMPONENTS AND INSTALLATION SHALL MEET THE REQUIREMENTS OF NFPA-96, NFPA-7A, R-102 AND APPLICABLE CODES AND STANDARDS.
- OUTLETS OF EXHAUST FANS SHALL BE AT LEAST 40 INCHES ABOVE ROOF LINE.
- EXHAUST FANS SHALL BE LOCATED A MINIMUM OF 10 FEET FROM ANY FRESH AIR INTAKE. MEASUREMENT SHALL BE MADE USING STRETCHED STRING METHOD.
- HOOD EXHAUST DUCTWORK SHALL BE 16 GA. BLACK STEEL WITH CONTINUOUS LIQUID TIGHT WELD OF JOINTS & SEAMS.
- TURNS IN GREASE EXHAUST DUCTWORK SHALL BE RADIUSSED EXCEPT THAT MITERED ELBOWS MAY BE USED WHERE DUCT MUST BE ENCLOSED IN A FRAMED CHASE.
- HOODS AND ASSOCIATED DUCTWORK SHALL BE INSTALLED PER NFPA 96 AND LOCAL CODES.
- ALL STAINLESS STEEL SHROUDS SHALL BE SUPPLIED BY HOOD MANUFACTURER AND INSTALLED BY CONTRACTOR ACCORDING TO MANUFACTURER'S RECOMMENDATIONS.
- HOODS, FANS AND ACCESS DOORS SHALL BE LISTED BY UNDERWRITERS LABORATORIES INC. AND SHALL MEET REQUIREMENTS OF NFPA-96.
- SLOPE ALL GREASE EXHAUST DUCT BACK TO HOOD AT 1" PER FOOT OF RUN.
- CHICK-FIL-A MAINTAINS A NATIONAL ACCOUNT WITH LDI MANUFACTURING. FOR QUESTIONS, CONTACT SUSAN ERNY AT 1-800-366-2001.

SIDE VIEW OF HOOD

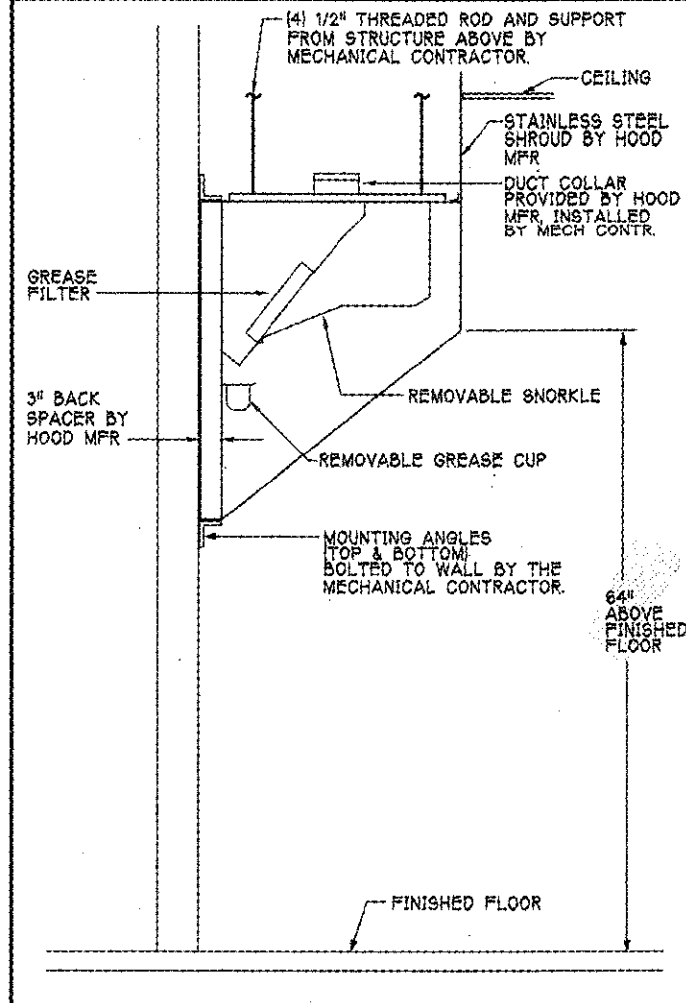

HOOD SCHEDULE

MARK	CFM	SP AT COLLAR	TYPE	COLLAR SIZE	LENGTH	HEIGHT	DEPTH	MANUFACTURER	MODEL	REMARKS
HOOD#1	1144	.75"	BACK SHELF	10"x10"	8'0"	45"	3"	LDI MFG CO.	ELS-M	1,2,3,4,5,6,7
HOOD#2	1648	.75"	BACK SHELF	12"x12"	5'10"	45"	3"	LDI MFG CO.	ELS-M	1,2,4,6,7
REMARKS	1) STAINLESS STEEL CONSTRUCTION. 2) MAKE-UP PROVIDED THROUGH ROOFTOP EQUIPMENT. 3) PROVIDE COOKING TIMER BRACKET. 4) PROVIDE SHROUD. 5) PROVIDE RECESSED ANSUL CABINET. 6) PROVIDE ANSUL WET FIRE EXTINGUISHING SYSTEM. 7) PROVIDE 3" BACK SPACER.									

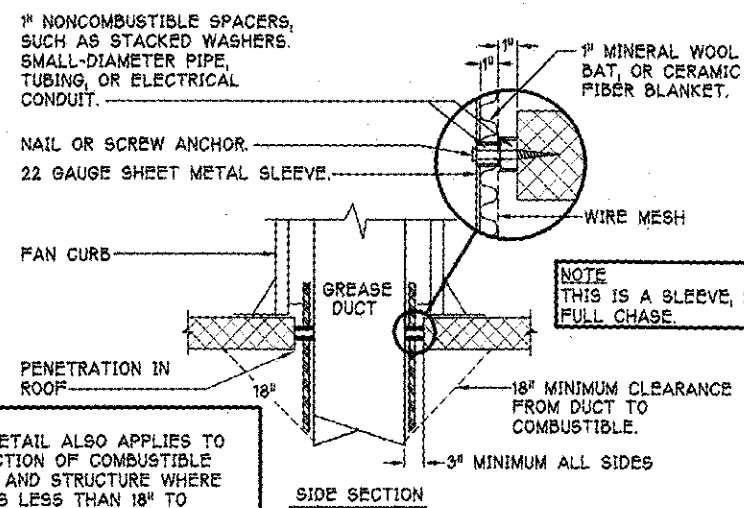
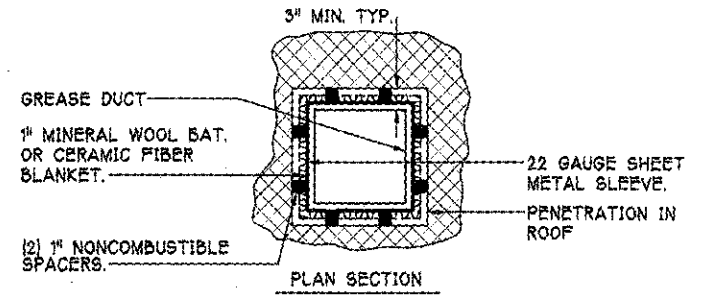

NOTE: THIS DETAIL ALSO APPLIES TO PROTECTION OF COMBUSTIBLE WALLS AND STRUCTURE WHERE DUCT IS LESS THAN 18" TO THESE COMBUSTIBLE COMPONENTS.

GREASE EXHAUST DUCT CLEARANCE REDUCTION SYSTEM

1 M2 SCALE: NONE

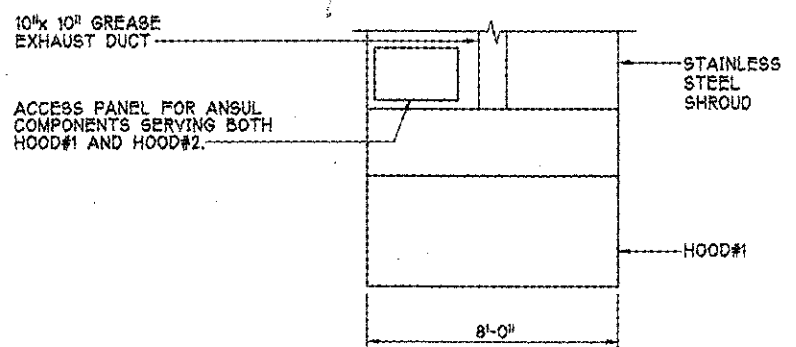

SECTION "C-C"

ANSUL ACCESS PANEL

SCALE: NONE

ANSUL REMOTE PULL STATION BETWEEN HANDSINK AND SHELVING. J-BOX AND CONDUIT ARE BY ELECTRICAL. PROVIDE RED BAKELITE LABEL WITH 1/2" HIGH LETTERS INDICATING THE HOODS SERVED.

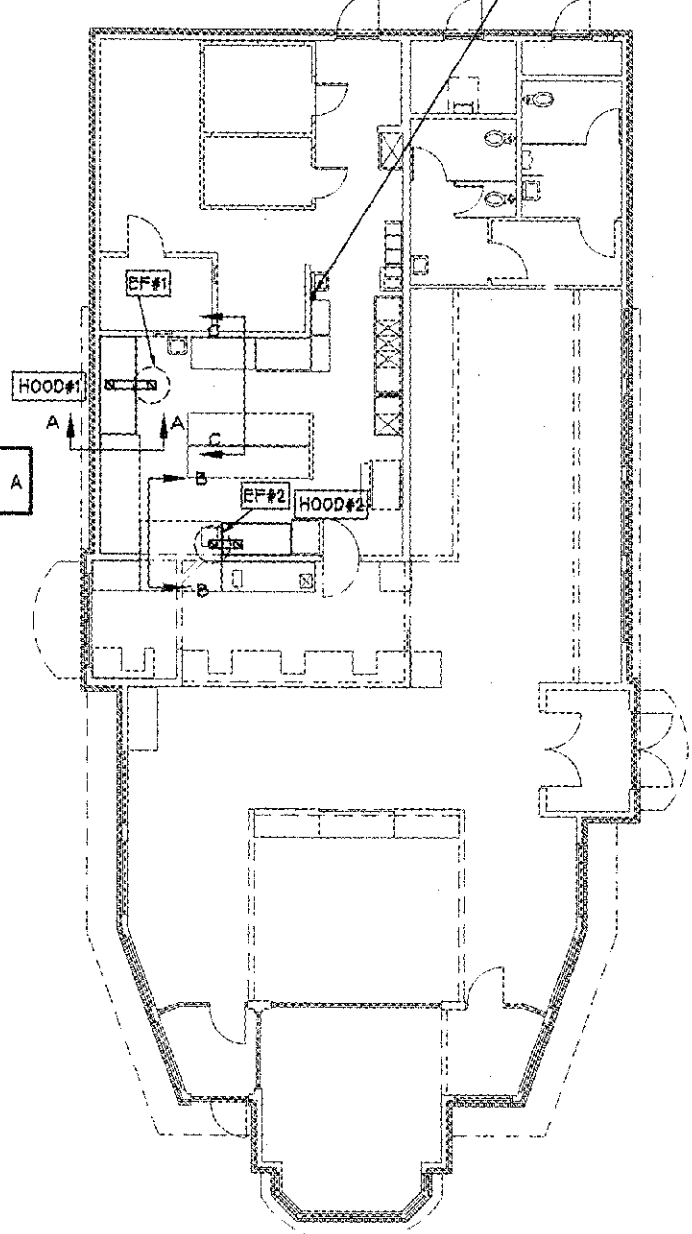

NOTE: SEE ARCH. PLANS FOR HOOD LOCATIONS.

HOOD LAYOUT

SCALE: 1/8"=1'-0"

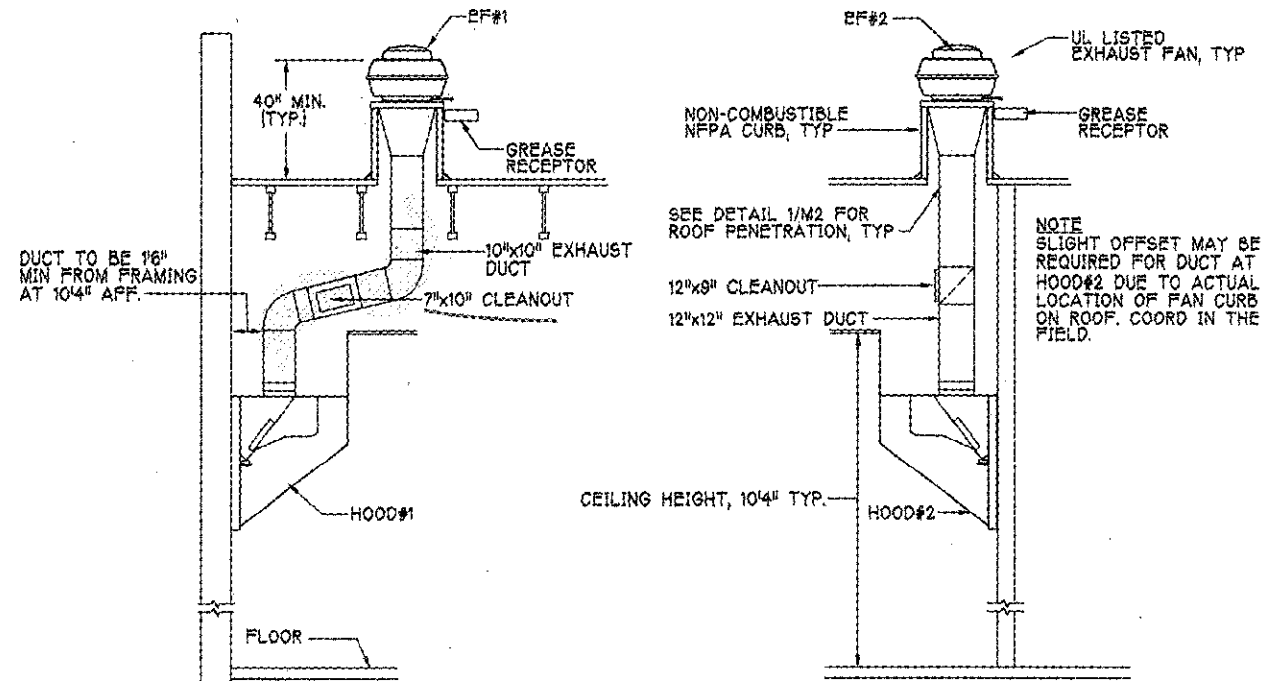

HOOD ELEVATIONS

SCALE: NONE

CHICK-FIL-A S97-100
Cotswold Shopping Center
4421 Randolph Road
Charlotte, North Carolina



BEHNER ENGINEERING, LLC
216 VALLEY ROAD
MORGESON, GEORGIA
30071
PHONE: 770/729-1422
FAX: 770/729-0480
E-MAIL: rb@behner.com



REVISIONS

FILE NUMBER
01010

DATE
02/12/01

HOOD DETAILS AND SCHEDULES

M2
Charlotte, NC

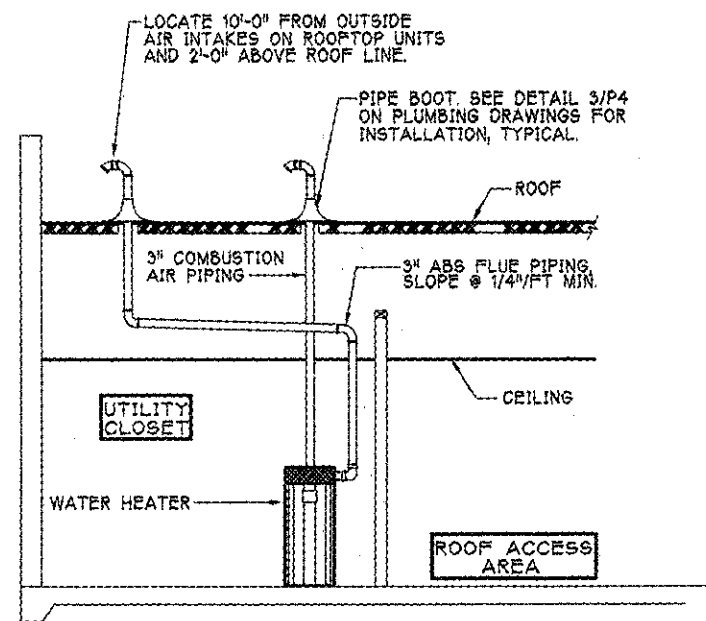

1 WATER HEATER VENT/C.A. ROUTING
M3 SCALE: NONE

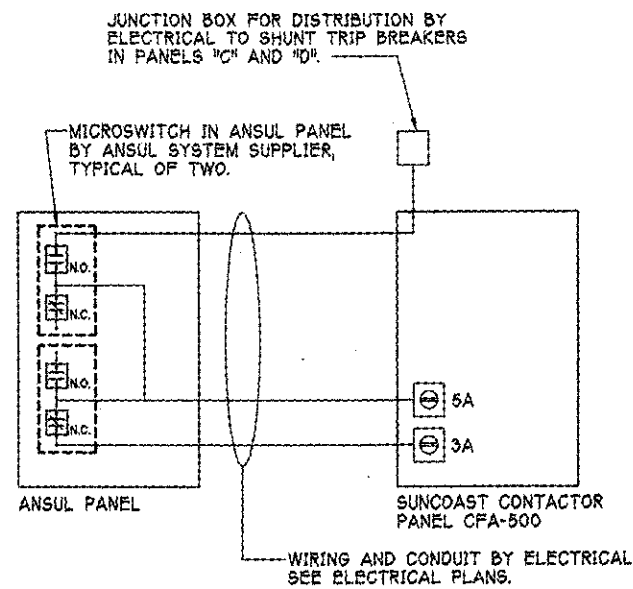

2 ANSUL WIRING DIAGRAM
M3 SCALE: NONE

GAS FIRED ROOFTOP UNIT SCHEDULE

MARK	COOLING CAPACITY (MBH)		HEATING CAPACITY (MBH)		FAN SECTION (CFM)				MODEL	MANUFACTURER	REMARKS
	TOTAL	SENS	INPUT	OUTPUT	SUPPLY	O.A.	HP	ESP			
AC#1	122.6	84.5	235.0	188.0	3,400	850	2	.65	LGA120HH	LENNOX	1,2,3,4,5,6,7,8,9,10,11,12,13
AC#2	146.2	102.3	235.0	188.0	4,400	1,200	3	.65	LGA150SH	LENNOX	1,2,3,4,5,7,8,9,10,11,12,13
AC#3	147.4	106.1	235.0	188.0	4,920	1,180	5	.65	LGA150SH	LENNOX	1,2,3,4,5,6,7,8,9,10,11,12,13
AC#4	63.2	46.1	78.0	61.6	2,000	300	1.5	.65	LGA060HS	LENNOX	1,2,3,4,5,6,7,8,9,10,11,12,13

NOTES: COOLING CAPACITIES ARE GROSS, BASED ON INDOOR Edb: 80F, INDOOR Ewb: 67F, OUTDOOR Edb: 85F

REMARKS:

- SEE DWG. M-4 FOR CONTROLS, SMOKE DETECTORS AND SEQUENCE OF OPERATION.
- PROVIDE AUTOMATIC 0-100% OUTSIDE AIR DAMPER.
- PROVIDE 14" HIGH ROOF CURB.
- CONTRACTOR SHALL REFER TO ROOF FRAMING PLAN FOR EXACT A/C UNIT LOCATIONS.
- FRESH AIR INTAKES SHALL BE LOCATED A MINIMUM OF 10'-0" FROM ANY FLUE, VENT OR EXHAUST FAN.
- PROVIDE FACTORY INSTALLED 115V GFI SERVICE OUTLET.
- SEE ELECTRICAL DRAWINGS FOR ELECTRICAL CHARACTERISTICS PRIOR TO ORDERING EQUIPMENT.
- ROUTE CONTROL AND POWER WIRING THRU FACTORY BASE FAN CONNECTION.
- PROVIDE FACTORY INSTALLED NON-FUSED DISCONNECT.
- PROVIDE COIL HAIL GUARD ON FL, TX AND OK PROJECTS.
- PROVIDE 2" FARR 30/30 THROW AWAY FILTERS.
- PROVIDE HINGED PANELS FOR FILTER ACCESS, FAN MOTOR ACCESS, COMPRESSOR ACCESS AND CONTROL COMPARTMENT ACCESS.
- CHANGE HEATING SECTION SPDUS AT LOCATIONS WHERE ELEVATION EXCEEDS 2000' ABOVE SEA LEVEL AS RECOMMENDED BY MANUFACTURER.

EXHAUST FAN SCHEDULE

MARK	CFM	ESP	RPM							TIP SPEED	HP	AREA SERVED	MODEL	MANUFACTURER	REMARKS
			500'	1000'	2000'	3000'	4000'	5000'	6000'						
EF#1	1144	1.25	1757	1750	1750	1782	1802	1826	1848	7343	1/2	HOOD#1	150VH55	LOREN COOK	1,2,3,4,6
EF#2	1648	1.25	1461	1470	1478	1487	1516	1535	1555	6311	3/4	HOOD#2	166VH85	LOREN COOK	1,2,3,4,6
EF#3	830	.375	1625	1625	1625	1625	1625	1625	1625	4258	1/8	RESTROOMS	ACED100G150M	LOREN COOK	2,5,7,8

NOTES: GREASE EXHAUST FAN RPM BASED ON 110 DEGREE F AIR AT DIFFERENT ELEVATIONS ABOVE SEA LEVEL.

REMARKS:

- PROVIDE NFPA ROOF CURB.
- PROVIDE NON-FUSED DISCONNECT.
- PROVIDE FACTORY HINGED ACCESS.
- PROVIDE AND INSTALL FACILITEC G2 DRIP GUARD. DRIP GUARD SHALL BE ORDERED AND INSTALLED BY THE MECHANICAL CONTRACTOR. THE COST OF THE DRIP GUARD IS BILLED TO CFA DIRECTLY BY FACILITEC. THE MECHANICAL CONTRACTOR IS TO CONTACT MR. JEAN JODOIN AT FACILITEC AT 800-284-8273 FOR ORDERING AND SHIPPING ARRANGEMENTS.
- PROVIDE BIRDSCREEN.
- STARTER BY ELECTRICAL CONTRACTOR.
- INTERLOCK WITH LIGHTS BY ELECTRICAL CONTRACTOR.
- PROVIDE 12" HIGH CURB.

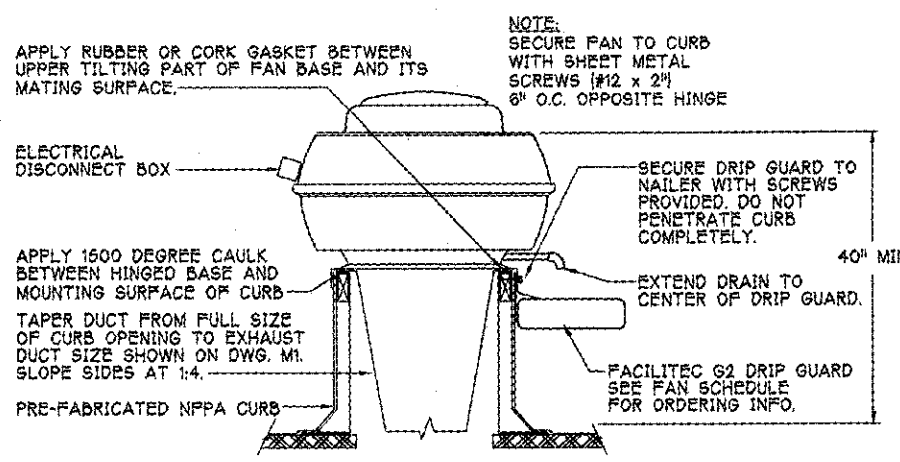

3 KITCHEN HOOD EXHAUST FAN
M3 SCALE: NONE

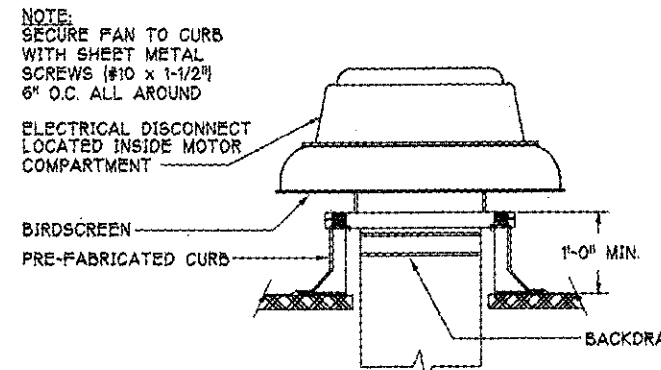

4 RESTROOM EXHAUST FAN
M3 SCALE: NONE

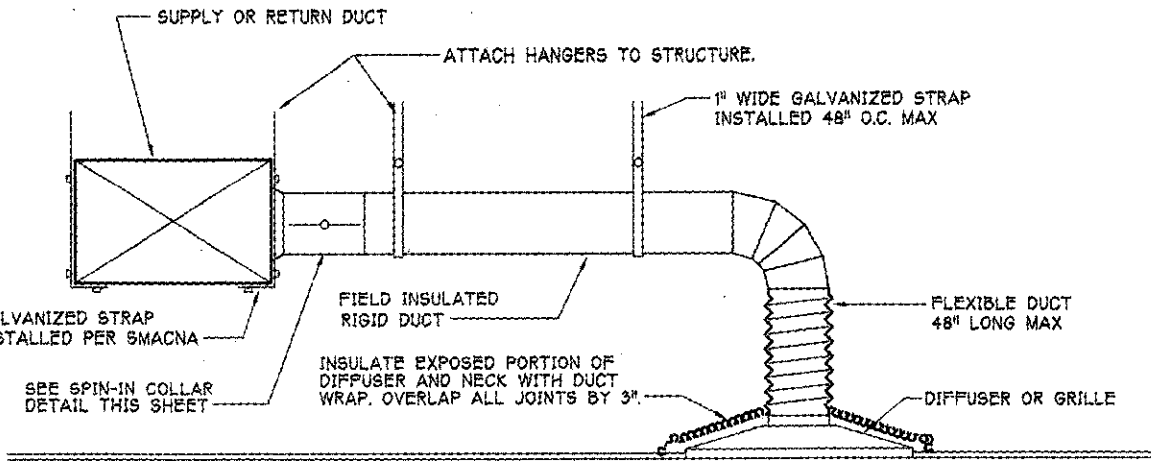

5 DIFFUSER TAKE-OFF
M3 SCALE: NONE

DAMPER CONTROL HANDLE MUST BE LEFT EXPOSED. ATTACH A YELLOW FLUORESCENT CONSTRUCTION RIBBON TO THE HANDLE. RIBBON MUST HANG 12" BELOW DUCT AND BE EASILY IDENTIFIABLE FOR TEST AND BALANCE CONTRACTOR.

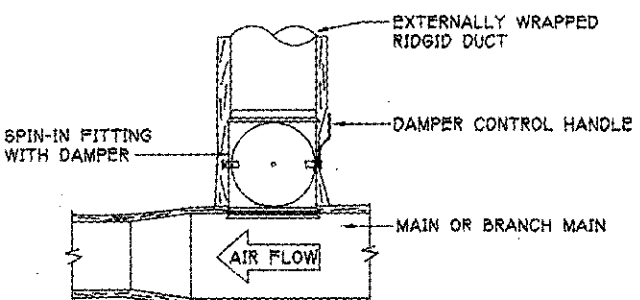

6 SPIN-IN COLLAR
M3 SCALE: NONE

AIR DEVICE SCHEDULE

MARK	DESCRIPTION	LOCATION	SIZE	CEILING TYPE	REMARKS
A	METALAIRE MODEL 7600AL-6 ALUMINUM SUPPLY AIR DIFFUSER WITH AIR PATTERN CONTROLLERS.	DINING AREA KITCHEN	24x24	LAY-IN	1,3
B	METALAIRE MODEL 7600AL-6 ALUMINUM SUPPLY AIR DIFFUSER WITH AIR PATTERN CONTROLLERS REMOVED.	KITCHEN	24x24	LAY-IN	1
C	METALAIRE MODEL 7000-1 ALUMINUM SUPPLY AIR DIFFUSER WITH AIR PATTERN CONTROLLERS.	VESTIBULES RESTROOMS	16x16	GYPSUM	1,3,5
D	METALAIRE MODEL H40040 DOUBLE DEFLECTION ALUMINUM SIDEWALL SUPPLY REGISTER WITH OBD, FRONT BLADE PARALLEL TO LONG SIDE.	PLAYGROUND	12x10	NA	1
E	METALAIRE MODEL 7000R-1 ALUMINUM RETURN AIR GRILLE.	VESTIBULES RESTROOMS	16x16	GYPSUM	1,4,5
F	METALAIRE MODEL 7600AL-6 ALUMINUM RETURN AIR GRILLE.	DINING/KITCHEN PLAYGROUND	24x24	LAY-IN	1,2
G	METALAIRE MODEL V40040 DOUBLE DEFLECTION ALUMINUM SIDEWALL SUPPLY REGISTER WITH OBD, FRONT BLADE PARALLEL TO SHORT SIDE.	PLAYGROUND	12x10	NA	1
H	METALAIRE MODEL 800 ROUND, STEP DOWN ALUMINUM SURFACE MOUNT SUPPLY DIFFUSER.	OFFICE	8	LAY-IN	1,5,6

REMARKS:

- STANDARD OFF WHITE FINISH.
- PROVIDE MODEL RSD NECK DAMPER.
- FOUR WAY THROW UNLESS NOTED OTHERWISE ON DWG M-1.
- PROVIDE MODEL RSD NECK DAMPER ON UNITS IN RESTROOMS.
- PROVIDE MODEL TR SQUARE TO ROUND NECK TRANSITION.
- PROVIDE 800D NECK DAMPER, ADJUSTABLE THRU DIFFUSER FACE.

AIR DOOR SCHEDULE

MARK	CFM	VELOCITY	HEATING CAP	HP	AREA SERVED	MODEL	MANUFACTURER	REMARKS
FF#1	1700	1950	NA	1/2	REAR DOOR	42-C	MARS	1
FF#2	1215	1500	6000 W	1/4	DRIVE THRU	C3606-1125HFD	LEADING EDGE	2

REMARKS:

- PROVIDE PLUNGER TYPE MICRO-SWITCH.
- PROVIDE 24V HEAT/OFF/ON WALL MOUNT THERMOSTAT.

CHICK-FIL-A 997-100
Catswold Shopping Center
4421 Randolph Road
Charlotte, North Carolina

BENNER ENGINEERING, LLC
216 VALLEY ROAD
NORCROSS, GEORGIA
30071
PHONE: 770/728-1422
FAX: 770/728-0490
E-MAIL: rbenner@bennereng.com



REVISIONS

FILE NUMBER
01010

DATE
02/12/01

MECHANICAL
DETAILS &
SCHEDULES

M3
Charlotte, NC

MECHANICAL SPECIFICATIONS

PART I GENERAL

1. FURNISH ALL MATERIALS, LABOR, TOOLS, TRANSPORTATION AND INCIDENTALS TO COMPLETE IN EVERY DETAIL, AND LEAVE IN WORKING ORDER ALL ITEMS CALLED FOR HEREIN OR SHOWN ON THE ACCOMPANYING DRAWINGS.
2. IT IS THE RESPONSIBILITY OF CONTRACTOR TO READ ALL SPECIFICATIONS AND CONSULT ALL DRAWINGS WHICH MAY AFFECT THE INSTALLATION AND COORDINATION OF HIS WORK WITH OTHER TRADES. CONTRACTOR SHALL COORDINATE AND MAKE MINOR ADJUSTMENTS IN LOCATION OF EQUIPMENT AND MATERIALS AS NECESSARY TO SECURE COORDINATION.
3. LAYOUT SHOWN IN DRAWINGS IS BASED ON A PARTICULAR MAKE OF EQUIPMENT. CONTRACTOR SHALL PROVIDE SIX SUBMITTAL SETS OF SHOP DRAWINGS TO ENGINEER FOR APPROVAL PRIOR TO STARTING WORK. IF ANOTHER MAKE OF EQUIPMENT IS DESIRED, THESE SUBMITTALS SHALL ALSO SHOW ALL REQUIRED MODIFICATIONS AND CHANGES, INCLUDING THOSE INVOLVING OTHER TRADES, AND COST THEREOF SHALL BE INCLUDED IN HIS BID. CONTRACTOR MUST RECEIVE APPROVED SUBMITTAL COPY, SIGNED BY ENGINEER BEFORE PROCEEDING WITH ANY MODIFICATIONS. WORK INSTALLED USING UNAPPROVED SUBSTITUTIONS SHALL BE REPLACED AT NO ADDITIONAL COST TO THE OWNER.
4. CONTRACTOR SHALL VISIT THE SITE AND FULLY INFORM HIMSELF CONCERNING ALL CONDITIONS AFFECTING SCOPE OF WORK. FAILURE TO DO SO SHALL NOT RELIEVE CONTRACTOR OF ANY RESPONSIBILITY IN THE PERFORMANCE OF HIS WORK. ALL WORKMANSHIP SHALL BE OF THE HIGHEST QUALITY IN ACCORDANCE WITH THE BEST PRACTICES OF THE TRADE BY CRAFTSMEN SKILLED IN THIS PARTICULAR WORK. CONTRACTOR SHALL FILE ALL DRAWINGS, PAY ALL FEES AND OBTAIN ALL PERMITS AND CERTIFICATES OF INSPECTION RELATIVE TO THIS WORK.
5. COMPLETED INSTALLATION SHALL CONFORM TO ALL APPLICABLE FEDERAL, STATE AND LOCAL CODES AND ORDINANCES, INCLUDING BUT NOT LIMITED TO THE LATEST APPROVED EDITIONS OF NFPA-96, NFPA-90A, NFPA-94, SMACNA, ASHRAE 90.1 AND ASHRAE 62-88.
6. SYSTEM LAYOUT IS SCHEMATIC AND EXACT LOCATIONS SHALL BE DETERMINED BY STRUCTURAL CONDITIONS, COORDINATION WITH OTHER TRADES, COORDINATION WITH FINISHES AND OTHER CONDITIONS. STRUCTURAL SUPPORTS SHALL NOT BE CUT OR ALTERED TO ASSURE FIT OF HVAC SYSTEM. TEN FOOT CLEARANCE SHALL BE MAINTAINED BETWEEN OUTSIDE AIR INTAKES AND EXHAUST FANS AND PLUMBING VENT TERMINALS.
7. CONTRACTOR SHALL BE RESPONSIBLE FOR ALL DEFECTS, REPAIRS AND REPLACEMENTS IN MATERIALS AND WORKMANSHIP FOR A PERIOD OF ONE (1) YEAR AFTER FINAL PAYMENT IS APPROVED. CONTRACTOR SHALL HONOR FACTORY WARRANTIES ON ALL EQUIPMENT PROVIDED AS PART OF THIS SYSTEM.
8. UPON COMPLETION OF PROJECT, ALL SYSTEM EQUIPMENT AND MATERIALS SHALL BE IN NEW, CLEAN CONDITION WITH ALL DAMAGE RESTORED TO CONDITION ACCEPTABLE TO THE OWNER'S REPRESENTATIVE. ALL EQUIPMENT, COMPONENTS AND DUCTWORK SHALL BE INSPECTED AND THOROUGHLY CLEANED, READY FOR USE. AT COMPLETION OF JOB, ALL MISCELLANEOUS TOOLS, SCAFFOLDING, SURPLUS MATERIALS, RUBBISH AND DEBRIS SHALL BE REMOVED BY CONTRACTOR.
9. IF HVAC EQUIPMENT IS USED FOR TEMPORARY HEATING, ETC., THE CONTRACTOR SHALL ASSUME THE RESPONSIBILITY FOR CLEANING COILS, ETC. FINAL PERMANENT CONNECTIONS OF SERVICES TO UNITS SHALL BE COMPLETE PRIOR TO ANY START-UP OF EQUIPMENT. PROVIDE NEW FILTERS AT WORK COMPLETION.
10. CONTRACTOR SHALL SUBMIT THREE (3) SETS OF INSTRUCTION BOOKS, INCLUDING INSTALLATION, OPERATION AND MAINTENANCE INSTRUCTIONS, PAMPHLETS OR BROCHURES AND ALL EQUIPMENT WARRANTIES OBTAINED FROM EACH MANUFACTURER OF EQUIPMENT TO OWNER'S REPRESENTATIVE.
11. DRAWINGS ARE DIAGRAMMATIC AND SHALL NOT BE SCALED FOR EXACT SIZES OR LOCATIONS. THEY ARE NOT INTENDED TO DISCLOSE ABSOLUTE OR UNCONDITIONAL KNOWLEDGE OF ACTUAL FIELD CONDITIONS.

PART II PRODUCTS

1. HEATING AND COOLING EQUIPMENT

- A. FURNISH AND INSTALL ROOFTOP SINGLE PACKAGE COMBINATION ELECTRIC COOLING AND NATURAL GAS FIRED HEATING UNITS BY LENNOX AS SHOWN ON DRAWINGS. EQUIPMENT SHALL BE ARI CERTIFIED AND A.G.A. AND U.L. LISTED.
- B. UNIT SHALL BE FACTORY ASSEMBLED, TESTED AND HAVE COMPLETE REFRIGERANT R-22 CHARGE, READY TO OPERATE. ALL TUBING JOINTS SHALL BE BRAZED. COILS SHALL BE MINIMUM OF 3-ROWS DEEP.
- C. INDOOR FAN SHALL BE STATICALLY AND DYNAMICALLY BALANCED, DOUBLE INLET, FORWARD CURVED BELT DRIVEN BLOWER CAPABLE OF DELIVERING DESIGN CFM. FAN SHALL BE QUIET IN OPERATION AND INTERNALLY VIBRATION ISOLATED.
- D. FILTERS SHALL BE THROW AWAY TYPE, FARR 30/30 2" OR EQUAL. A CLEAN SET OF REPLACEMENT FILTERS SHALL BE PROVIDED AND INSTALLED BY CONTRACTOR AFTER SUCCESSFUL START-UP OF EQUIPMENT AND AGAIN PRIOR TO OPENING.
- E. ACCESSORIES SHALL INCLUDE LOW AND HIGH PRESSURE SAFETIES, CRANK CASE HEATER, OVERCURRENT AND OVERTEMPERATURE SAFETY, COMPRESSOR VIBRATION ISOLATORS, FILTER DRIERS, REFRIGERANT

SERVICE VALVES, COIL HAIL GUARDS (FL, TX, OK ONLY), CONVENIENCE OUTLETS FACTORY INSTALLED ON SCHEDULED UNITS, UNIT MOUNTED NON-FUSED DISCONNECTS, LOW AMBIENT OPERATION DOWN TO 30 DEGREES F AND EVAPORATOR FREEZE STAT.

- F. COMPRESSORS SHALL BE FULLY HERMETIC SCROLL TYPE WITH INTERNAL VIBRATION ISOLATORS. COMPRESSORS SHALL BE PROVIDED WITH A MINIMUM FIVE (5) YEAR FULL WARRANTY.
 - G. UNIT SHALL BE DOWN-DISCHARGE AS INDICATED ON THE DRAWINGS.
 - H. UNITS SHALL HAVE MOTORIZED TWO POSITION OUTSIDE AIR INTAKE DAMPERS CAPABLE OF ADMITTING UP TO 100% OUTSIDE AIR.
 1. THE UNIT HEAT EXCHANGERS SHALL BE STEEL WITH ALUMINIZED STEEL COATING. HEATING CONTROLS SHALL CONSIST OF REDUNDANT GAS VALVES, INTERMITTENT PILOT WITH ELECTRONIC SPARK OR HOT PLATE IGNITION SYSTEM, COMBUSTION/EXHAUST FAN PROTECTED BY CENTRIFUGAL SWITCHES, HEAT LIMIT SWITCHES, TIME-DELAY RELAY, FLAME, AND PILOT SENSORS. ALL UNITS SHALL BE CAPABLE OF TWO STAGES OF HEAT. HEAT EXCHANGES SHALL HAVE A TEN (10) YEAR WARRANTY. BURNERS SHALL BE ALUMINIZED IN-SHOT TYPE. THE DRAFT MOTOR SHALL BE MONITORED BY THE CONTROL SYSTEM.
 - J. CHICK-FIL-A MAINTAINS A NATIONAL ACCOUNT FOR EQUIPMENT WITH LENNOX CORPORATION. PRICING FOR THE EQUIPMENT HAS BEEN ESTABLISHED IN ADVANCE. CONTACT LENNOX NATIONAL ACCOUNTS AT 872-497-6785 FOR PRICING, ORDERING AND AVAILABILITY.
2. GENERAL EXHAUST AND KITCHEN HOOD FANS
 - A. FANS SHALL BE LOREN COOK MODELS, UP BLAST OR DOWN BLAST, CENTRIFUGAL OR PROPELLER, AS INDICATED ON DRAWINGS AND SHALL BE LOCATED WHERE SHOWN ON DRAWINGS. ALL FANS SHALL BE U.L. LISTED FOR INTENDED USE AND SHALL BEAR THE A.M.C.A. SEAL. MANUFACTURERS OTHER THAN LOREN COOK ARE NOT ACCEPTABLE. GREASE RECEPTOR ON HOOD FANS SHALL HAVE METAL TOP AND DRAINAGE TUBE.
 3. ROOF CURBS
 - A. EQUIPMENT MANUFACTURER SHALL PROVIDE ALL ROOF CURBS FOR ROOF MOUNTED EQUIPMENT.
 - B. CURB CONSTRUCTION AND HEIGHT FOR THE HOOD FANS SHALL CONFORM TO THE REQUIREMENTS OF NFPA 96.
 - C. THE RESTROOM EXHAUST FAN CURB SHALL BE 1'-0" HIGH MINIMUM.
 - D. ALL CURBS SHALL BE HAVE PERIMETER INSULATION PROVIDED AND INSTALLED BY THE ROOFING INSTALLER.
 - E. THE ROOFTOP EQUIPMENT CURBS SHALL HAVE A 2" THICK ACOUSTICAL INSULATION BLANKET APPLIED BETWEEN THE ROOF AND EQUIPMENT BY THE MECHANICAL CONTRACTOR.
 4. NON-GREASE DUCTWORK & INSTALLATION
 - A. ACCEPTABLE MANUFACTURERS OF INSULATION ARE MANVILLE, OWENS CORNING OR KNAUF.
 - B. ALL DUCTWORK, EXCEPT GREASE DUCT, SHALL BE SHEET METAL. SMACNA 1" W.C. PRESSURE CLASS STANDARDS AND RECOMMENDATIONS SHALL BE FOLLOWED WITH RESPECT TO MATERIALS, CONSTRUCTION, INSTALLATION AND SUPPORT OF ALL DUCTWORK. MINIMUM GAUGE ACCEPTABLE SHALL BE 24 GAUGE. ALL JOINTS SHALL BE SEALED WITH APPROVED DUCT SEALANT APPROVED FOR INTENDED USE. STANDARD DUCT TAPE IS NOT ACCEPTABLE. DUCT DIMENSIONS SHOWN ARE INSIDE CLEAR DIMENSIONS.
 - C. SUPPLY AIR DUCTWORK SERVING THE PLAYGROUND SHALL BE EITHER EXTERNALLY INSULATED WITH 2" THICK FIBERGLASS BATT DUCT WRAP INSULATION WITH VAPOR BARRIER OR SHALL BE LINED WITH 1" THICK FIBERGLASS DUCT LINER. PLAYGROUND UNIT RECTANGULAR RETURN AIR DUCTWORK SHALL BE LINED WITH 1" THICK ACOUSTICAL LINER.
 - D. RESTROOM RECTANGULAR EXHAUST AIR DUCTWORK SHALL BE LINED WITH 1" THICK FIBERGLASS DUCT LINER.
 - E. SUPPLY AND RETURN AIR DUCTWORK SERVING THE KITCHEN, SERVING AND DINING AREAS SHALL BE EXTERNALLY INSULATED WITH 2" THICK FIBERGLASS BATT DUCT WRAP INSULATION WITH VAPOR BARRIER.
 - F. TRUNK DUCTS SHALL BE ISOLATED FROM UNIT VIBRATION WITH THE USE OF NFPA AND U.L. APPROVED FLEXIBLE CONNECTORS IN BOTH SUPPLY AND RETURN.
 - G. ALL ROUND DUCT SHALL BE SIZED AS SHOWN ON DRAWINGS. INSULATED FLEXIBLE DUCT MAY BE UTILIZED FOR CONNECTION TO GRILLES AND REGISTERS ONLY IN MAXIMUM LENGTHS OF 4'-0", NO EXCEPTIONS. CONSTRUCTION OF FLEXIBLE SHALL INCLUDE SPIRAL METAL CORE WITH 1" FIBERGLASS INSULATION WITH VAPOR BARRIER. ALL COMPONENTS SHALL HAVE APPROPRIATE U.L. APPROVAL.
 - H. SINGLE THICKNESS TURNING VANES SHALL BE INSTALLED AT 90 DEGREE TURNS IN LOW PRESSURE MAIN SUPPLY DUCTS WHERE ANY ONE DIMENSION IS GREATER THAN 12".
 - I. RADIUS ELBOWS MAY BE SUBSTITUTED FOR 90 DEGREE ELBOWS AT THE DISCRETION OF THE CONTRACTOR. CENTERLINE RADIUS EQUAL TO 3W/2 PER FIGURE NO. 2-2 IN SMACNA HVAC DUCT CONSTRUCTION STANDARDS.
 5. AIR DEVICES
 - A. AIR DEVICES SHALL BE TITUS, KRUEGER OR METALAIR. COORDINATE FRAME TYPE WITH REFLECTED CEILING PLAN PRIOR TO ORDERING. ALL AIR DEVICES SHALL HAVE UNIFORM FACE DIMENSIONS UNLESS OTHERWISE NOTED. FURNISH AND INSTALL ACCESS DOORS IN GYPSUM CEILINGS AND WALLS FOR DAMPER ACCESS. PAINT ACCESS DOOR TO MATCH CEILING FINISH.
 - B. MANUAL VOLUME BALANCING DAMPERS SHALL HAVE WING NUTS EXTERNALLY LOCATED AT BOTH ENDS OF DAMPER SHAFT.
 6. PAINTING
 - A. ALL EQUIPMENT LOCATED OUTDOORS SHALL HAVE ANY SCRATCHES TOUCHED UP WITH PAINT OF THE SAME TYPE AND COLOR AS ORIGINAL.

7. CONTROLS

- A. SYSTEMS SHALL BE COMPLETE WITH CONNECTIONS TO CFA-500 TEMPERATURE CONTROL PANEL AS MANUFACTURED BY SUNCOAST ENVIRONMENTAL CONTROLS (S.E.C.) (PH: 877-544-6679). THE PANEL IS PROVIDED AND INSTALLED BY ELECTRICAL.
 - B. INSTALL A SMOKE DETECTOR IN THE RETURN AIR DUCT OF EACH AIR CONDITIONING UNIT HANDLING 2000 CFM OR MORE TO STOP THE INDOOR FAN AND CLOSE THE OUTSIDE AIR DAMPER IN THE EVENT OF EXCESSIVE TEMPERATURE OR SMOKE. SMOKE DETECTOR SHALL BE LOCATED PRIOR TO ANY EXHAUST FROM THE BUILDING OR MIXING WITH FRESH AIR MAKE-UP. UPON DETECTION, THE SYSTEM SHALL NOT RESTART UNTIL THE DEVICE IS MANUALLY RESET. DEVICES SHALL BE LOCATED WHERE THEY CAN BE EASILY ACCESSED AND WHERE CLEAR OF FILTERS.
 - C. CHICK-FIL-A HAS A NATIONAL ACCOUNT WITH SUNCOAST ENVIRONMENTAL CONTROLS FOR THE DETECTORS AND TEST/RESET STATIONS. PRICING FOR THE DETECTORS AND TEST/RESET STATIONS HAS BEEN ESTABLISHED IN ADVANCE. CONTACT S.E.C. FOR PURCHASE AND ORDERING INFORMATION. SMOKE DETECTORS AND REMOTE TEST/RESET STATIONS SHALL BE PROVIDED AND MOUNTED BY THE MECHANICAL CONTRACTOR. INSTALLATION BY MECHANICAL SHALL INCLUDE MOUNTING OF THE DEVICE AND ALL WIRING FROM THE DEVICE TO BOTH THE UNIT AND THE REMOTE TEST/RESET STATION. SMOKE DETECTOR SHALL BE POWERED FROM THE RTU CONTROL TRANSFORMER. ELECTRICAL WILL PROVIDE A JUNCTION BOX IN THE WALL WITH 1/2" CONDUIT STUBBED UP ABOVE THE CEILING FOR EACH REMOTE TEST STATION AS SHOWN ON THE ELECTRICAL PLANS. SMOKE DETECTORS SHALL BE AIR PRODUCTS AND CONTROLS RW SERIES IONIZATION TYPE 24V, MODEL RW-024-N. PROVIDE S.E.C. REMOTE TEST/RESET STATION MODEL AP-1 WITH POWER LED, ALARM LED, 90db HORN AND TEST/RESET BUTTON.
 - D. PROVIDE AN EMERGENCY SHUTDOWN TOGGLE SWITCH IN A SINGLE GANG BOX FOR EACH ROOFTOP UNIT. PUTTING THE SWITCH IN THE ON POSITION WILL CAUSE IMMEDIATE SHUTDOWN OF THE ROOFTOP UNIT. THE SWITCH SHALL CLOSE THE CIRCUIT FROM THE RTU 24V CONTROL POWER TO THE A55 CONTROLLER P110 PLUG, PIN #8. SEE DETAIL 1/M1 FOR SCHEMATIC SHOWING THE CORRECT CIRCUIT LOCATIONS. ALL WIRING SHALL BE 18 AWG. EACH TOGGLE SWITCH SHALL BE LABELED BY ROOFTOP UNIT NUMBER AND THE ON AND OFF POSITIONS SHALL BE LABELED. PROVIDE A SINGLE LABEL OVER BANK OF SWITCHES INDICATING "HVAC EMERGENCY SHUTDOWN". ALL LABELS SHALL BE ENGRAVED PLASTIC WITH WHITE LETTERS ON A RED BACKGROUND.
 - E. THE RESTROOM FAN SHALL BE INTERLOCKED TO THE LIGHTS SERVING THE MEN AND WOMEN'S RESTROOMS. THE HOOD FANS SHALL BE CONTROLLED VIA SWITCHES IN THE KITCHEN. WIRING, RELAYS AND SWITCHES FOR CONTROL OF ALL FANS ARE BY ELECTRICAL CONTRACTOR.
 - F. THE ROOFTOP UNIT THERMOSTATS ARE INTEGRATED INTO THE TEMPERATURE CONTROL PANEL AND ARE BY S.E.C. THE REMOTE TEMPERATURE SENSORS ARE PROVIDED BY S.E.C., AND ARE INSTALLED AND WIRED TO THE PANEL BY THE MECHANICAL CONTRACTOR. WIRING FROM THE ROOFTOP UNIT CONTROLS SECTION TO THE TEMPERATURE CONTROL PANEL SHALL BE BY THE MECHANICAL CONTRACTOR.
 - G. MECHANICAL CONTRACTOR SHALL INSTALL CONTROL WIRING IN 1/2" CONDUIT WHERE REQUIRED BY CODE. WHERE NOT REQUIRED TO BE IN CONDUIT, ALL WIRING SHALL BE RUN PARALLEL TO STRUCTURAL MEMBERS OR PERPENDICULAR WITH NO DIAGONAL ROUTING. ALL WIRING SHALL BE SECURED TO THE FRAMING TO PREVENT SAGGING IN RUNS. WIRING TO ROOFTOP UNITS SHALL BE ROUTED THROUGH THE FACTORY THRU-CURB FITTING IN THE UNIT CURB. WIRING SHALL BE INSTALLED IN ACCORDANCE WITH LATEST EDITION OF NEC. DISCONNECTS ARE TO BE FURNISHED AND INSTALLED BY THE MECHANICAL CONTRACTOR. ALL CONTROL WIRING AND CONTROL WIRING CONDUIT SHALL BE FURNISHED AND INSTALLED BY THE MECHANICAL CONTRACTOR.
- B. SEQUENCE OF OPERATION:
 - A. WHEN STORE IS OPEN, THE EXHAUST FANS AND ROOFTOP UNITS SHALL OPERATE THRU CONTROL OF THE SWITCHES AND SENSORS SHOWN ON THE MECHANICAL AND ELECTRICAL PLANS. THE ROOFTOP UNIT INDOOR FANS SHALL RUN CONTINUOUSLY AND THE OUTSIDE AIR DAMPERS SHALL REMAIN OPEN.
 - B. WHEN STORE IS CLOSED, THE EXHAUST FANS SHALL BE SWITCHED OFF AND THE THERMOSTATS SHALL BEGIN NIGHT SET-BACK MODE. OUTSIDE AIR DAMPERS AT THE ROOFTOP UNITS SHALL REMAIN CLOSED AT ALL AT ALL TIMES DURING NIGHT SET-BACK MODE.
 - C. HOOD EXHAUST FANS SHALL NOT BE CAPABLE OF OPERATION UNLESS SEC PANEL HAS BEEN PUT INTO "STORE OPEN" MODE.
 - D. ACTUATION OF ANSUL SYSTEM SHALL STOP ALL ROOFTOP UNITS, CLOSE THE O.A. DAMPERS AND START THE GREASE HOOD EXHAUST FANS. ALL WIRING EXTERNAL TO ACCOMPLISH THIS IS BY ELECTRICAL.
 - E. RESTROOM EXHAUST FAN SHALL ENERGIZE UPON OPERATION OF LIGHTS IN RESTROOMS.

PART III EXECUTION

1. FURNISH AND INSTALL SYSTEM IN ACCORDANCE WITH REFERENCED STANDARDS, APPLICABLE CODES, MANUFACTURER'S RECOMMENDATIONS AND AS INDICATED ON DRAWINGS.
2. OWNER SHALL TEST AND BALANCE MECHANICAL SYSTEM IN ACCORDANCE WITH AABC STANDARDS TO ASSURE CONFORMANCE WITH DESIGN. G.C. WILL MAKE MECHANICAL CONTRACTOR AVAILABLE DURING TEST AND BALANCE TO ASSIST TESTING AGENCY AND TO MAKE CORRECTIONS IMMEDIATELY NECESSARY. CONTRACTOR SHALL CORRECT ITEMS ON WRITTEN TEST AND BALANCE REPORT.
3. CONTRACTOR SHALL INSTRUCT THE OWNER'S REPRESENTATIVE IN ALL MATTERS PERTAINING TO THE PROPER MAINTENANCE OF EQUIPMENT FURNISHED UNDER THIS CONTRACT THROUGH DEMONSTRATION AND EXPLANATION OF OPERATING & MAINTENANCE MANUALS.
4. CONTRACTOR SHALL PROVIDE A "SAMPLE MAINTENANCE PROPOSAL" TO THE OWNER'S REPRESENTATIVE IN ALL MATTERS PERTAINING TO THE PROPER MAINTENANCE OF EQUIPMENT FURNISHED UNDER THIS CONTRACT.

CHICK-FIL-A 97-100
Cotswold Shopping Center
4421 Randolph Road
Charlotte, North Carolina



BENNER ENGINEERING, LLC

216 VALLEY ROAD
NORCROSS, GEORGIA
30071
PHONE: 770/728-1422
FAX: 770/728-0490
E-MAIL: rbenner@bennerspring.com



REVISIONS

FILE NUMBER

01010

DATE

02/12/01

MECHANICAL
SPECIFICATIONS

M4

Charlotte, NC