

FOR QUESTIONS, CALL THE
Highwoods Group
REGION 40
PHONE: (919) 875 - 0420
EMAIL: reg40@captiveaire.com

PATENT NUMBERS

AC-PSP (UNITED STATES) - US PATENT 7963830 B2.
AC-PSP WALL (CANADA) - CA PATENT 2820509.
AC-PSP ISLAND (CANADA) - CA PATENT 2520330.

HOOD INFORMATION - JOB#6648433

HOOD NO	TAG	MODEL	MANUFACTURER	LENGTH	MAX COOKING TEMP	TYPE	APPLIANCE DUTY	DESIGN CFM/FT	TOTAL EXH CFM	EXHAUST PLENUM RISER(S)						MUA CFM	AC CFM	HOOD CONSTRUCTION	HOOD CONFIG		
										WIDTH	LENG	HEIGHT	DIA	CFM	VEL				SP	END TO END	ROW
1		5424 ND-2-ACPSP-F	CAPTIVEAIRE	12' 9"	600 DEG	I	HEAVY	200	2550	10'	24'	4'		2550	1530	-0.966'	1300	696	430 SS WHERE EXPOSED	ALONE	ALONE

HOOD INFORMATION

HOOD NO	TAG	FILTER(S)					LIGHT(S)				UTILITY CABINET(S)				FIRE SYSTEM PIPING	HOOD HANGING WEIGHT	
		TYPE	QTY	HEIGHT	LENGTH	EFFICIENCY @ 7 MICRONS	QTY	TYPE	WIRE GUARD	LOCATION	SIZE	FIRE SYSTEM TYPE	SIZE	ELECTRICAL MODEL #			SWITCHES QUANTITY
1		CAPTRATE SOLID FILTER	9	16"	16"	85% SEE FILTER SPEC	8	L55 SERIES E26	NO	RIGHT	12"x54"x24"	TANK FS	4.0/4.0	SC-311110MA	1 LIGHT 1 FAN	YES	1213 LBS

HOOD OPTIONS

HOOD NO	TAG	OPTION
1		FIELD WRAPPER 10.00' HIGH FRONT, LEFT, RIGHT. INSULATION FOR BACK OF HOOD. RISER SENSOR INSTALL 6IN PLEN. RIGHT VERTICAL END PANEL 27' TOP WIDTH, 21' BOTTOM WIDTH, 80' HIGH INSULATED 430 SS. LEFT VERTICAL END PANEL 27' TOP WIDTH, 21' BOTTOM WIDTH, 80' HIGH INSULATED 430 SS. FULL DIMENSION HANGING BRACKET - FRONT.

PERFORATED SUPPLY PLENUM(S)

HOOD NO	TAG	POS	LENGTH	WIDTH	HEIGHT	RISER(S)					
						TYPE	WIDTH	LENG	DIA	CFM	SP
1		Front	165'	19'	6'	MUA	6"	28"		432	0.127"
						MUA	6"	28"		432	0.127"
						MUA	6"	28"		432	0.127"
						AC		8"	116	0.043"	
						AC		8"	116	0.043"	
						AC		8"	116	0.043"	
						AC		8"	116	0.043"	
						AC		8"	116	0.043"	

1" LAYER OF INSULATION FACTORY INSTALLED IN INTERNAL BACK STANDOFF. MEETS 0 INCH REQUIREMENTS FOR CLEARANCE TO COMBUSTIBLE SURFACES.

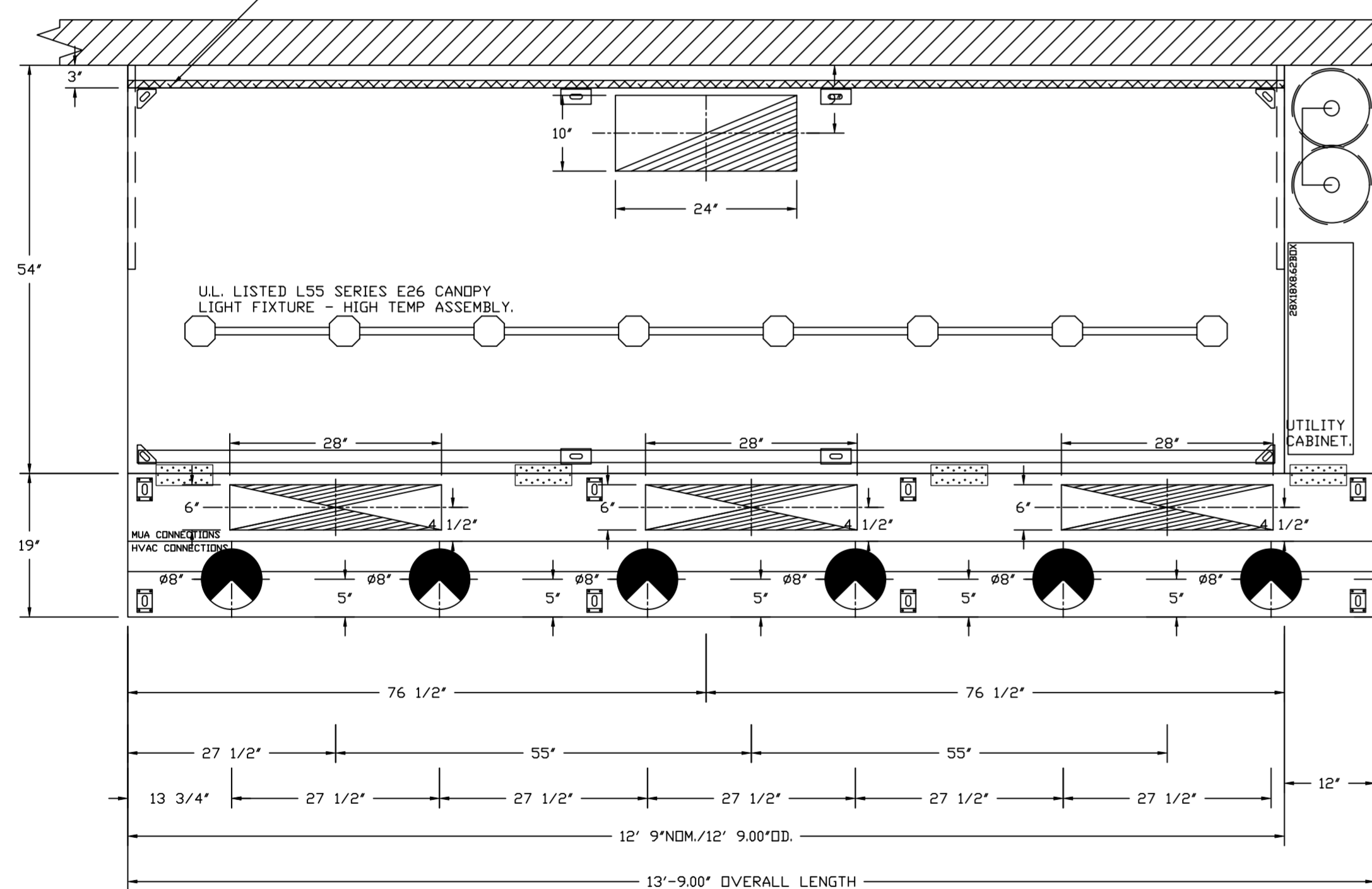

PLAN VIEW - HOOD #1
12' 9.00" LONG 5424ND-2-ACPSP-F
NOTE: ADDITIONAL HANGING ANGLES PROVIDED FOR HOODS 12' AND LONGER.

ACPSP SHIPS LOOSE FOR FIELD INSTALLATION

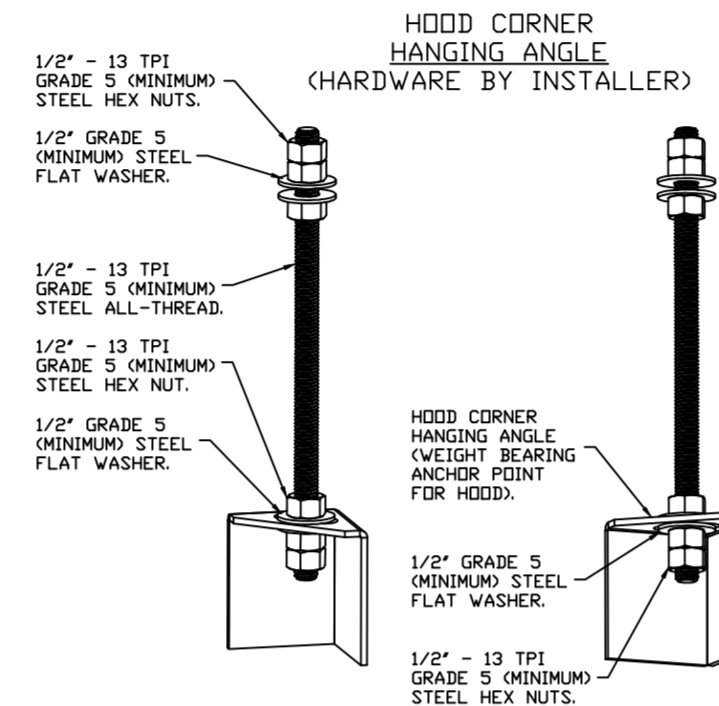

ASSEMBLY INSTRUCTIONS

HANGING ANGLE MUST BE SUPPORTED WITH 1/2" - 13 TPI GRADE 5 (MINIMUM) ALL-THREAD. SANDWICH HANGING ANGLES AND CEILING ANCHOR POINTS WITH 1/2" GRADE 5 (MINIMUM) STEEL FLAT WASHERS AND 1/2" - 13 TPI GRADE 5 (MINIMUM) HEX NUTS AS SHOWN. MUST USE DOUBLED HEX NUT CONFIGURATION BENEATH HOOD HANGING ANGLES AND ABOVE CEILING ANCHORS. MAINTAIN 1/4" OF EXPOSED THREADS BENEATH BOTTOM HEX NUT. TORQUE ALL HEX NUTS TO 57 FT-LBS.

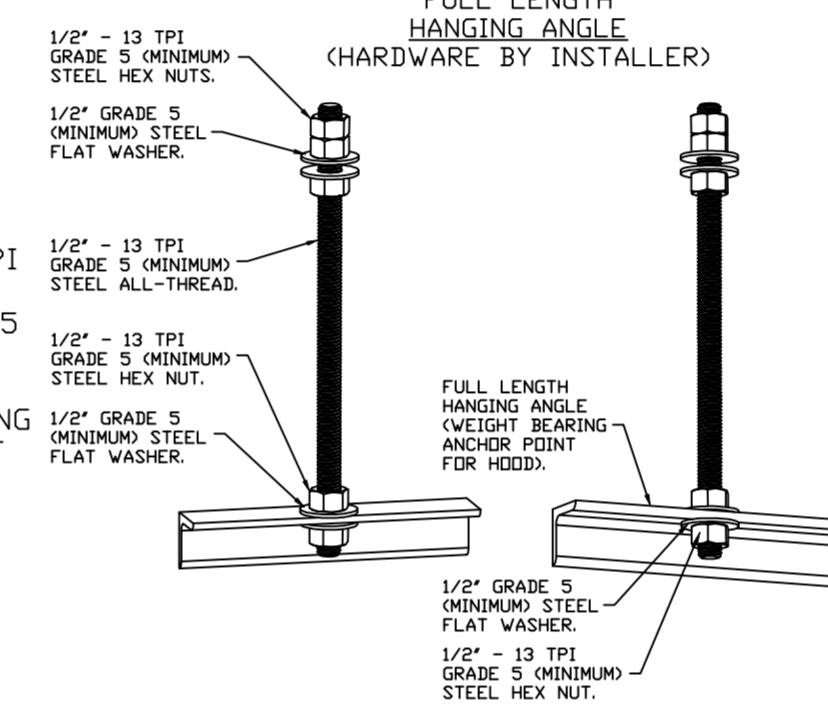

ASSEMBLY INSTRUCTIONS

HANGING ANGLE MUST BE SUPPORTED WITH 1/2" - 13 TPI GRADE 5 (MINIMUM) ALL-THREAD. SANDWICH HANGING ANGLES AND CEILING ANCHOR POINTS WITH 1/2" GRADE 5 (MINIMUM) STEEL FLAT WASHERS AND 1/2" - 13 TPI GRADE 5 (MINIMUM) HEX NUTS AS SHOWN. MUST USE DOUBLED HEX NUT CONFIGURATION ABOVE CEILING ANCHORS. SINGLE HEX NUT BENEATH HANGING ANGLE IS ACCEPTABLE FOR FULL LENGTH HANGING ANGLES. MAINTAIN 1/4" OF EXPOSED THREADS BENEATH BOTTOM HEX NUT. TORQUE ALL HEX NUTS TO 57 FT-LBS.

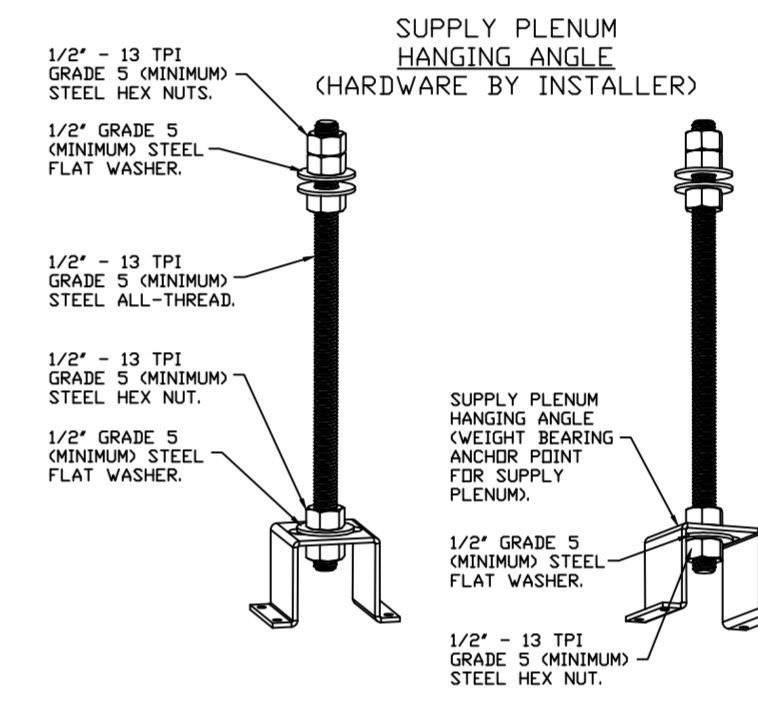

ASSEMBLY INSTRUCTIONS

HANGING ANGLE MUST BE SUPPORTED WITH 1/2" - 13 TPI GRADE 5 (MINIMUM) ALL-THREAD. SANDWICH HANGING ANGLES AND CEILING ANCHOR POINTS WITH 1/2" GRADE 5 (MINIMUM) STEEL FLAT WASHERS AND 1/2" - 13 TPI GRADE 5 (MINIMUM) HEX NUTS AS SHOWN. MUST USE DOUBLED HEX NUT CONFIGURATION ABOVE CEILING ANCHORS. SINGLE HEX NUT BENEATH HANGING ANGLE IS ACCEPTABLE FOR PSP HANGING ANGLES. MAINTAIN 1/4" OF EXPOSED THREADS BENEATH BOTTOM HEX NUT. TORQUE ALL HEX NUTS TO 57 FT-LBS.

SPECIFICATION: CAPTRATE® GREASE-STOP® SOLID FILTER

THE CAPTRATE GREASE-STOP SOLID FILTER IS A SINGLE-STAGE FILTER FEATURING A UNIQUE S-BAFFLE DESIGN IN CONJUNCTION WITH A SLOTTED REAR BAFFLE DESIGN, TO DELIVER EXCEPTIONAL FILTRATION EFFICIENCY.

FILTER IS STAINLESS STEEL CONSTRUCTION, AND SIZED TO FIT INTO STANDARD 2-INCH DEEP HOOD CHANNEL(S).

UNITS SHALL INCLUDE STAINLESS STEEL HANDLES AND A FASTENING DEVICE TO SECURE THE TWO COMPONENTS WHEN ASSEMBLED.

GREASE EXTRACTION EFFICIENCY PERFORMANCE SHALL REMOVE AT LEAST 75% OF GREASE PARTICLES FIVE MICRONS IN SIZE, AND 85% GREASE PARTICLES SEVEN MICRONS IN SIZE AND LARGER, WITH A CORRESPONDING PRESSURE DROP NOT TO EXCEED 1.0 INCHES OF WATER GAUGE.

THE CAPTRATE GREASE-STOP SOLID WAS TESTED TO ASTM STANDARD ASTM F2519-05, MANUFACTURER APPROVED FOR USE IN SOLID FUEL APPLICATIONS AS A SPARK ARRESTER.

EFFICIENCY VS. PARTICLE DIAMETER

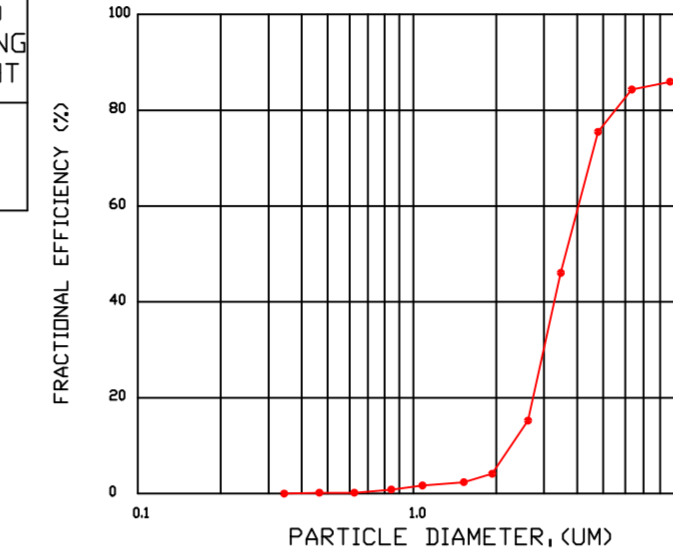

PRESSURE DROP VS. FLOW RATE

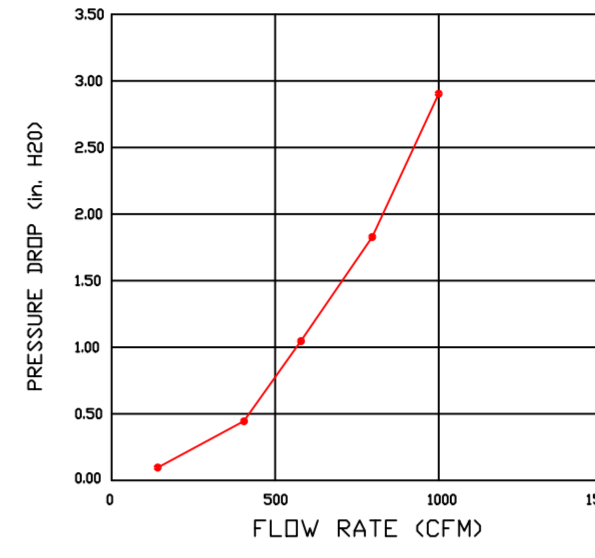

CAPTRATE FILTERS ARE BUILT IN COMPLIANCE WITH:
NFPA #96.
NSF STANDARD #2.
UL STANDARD #1046.
INT. MECH. CODE (IMC).
ULC-S649.



REVISIONS

DESCRIPTION	DATE



CHIPOTLE JEFFERSONVILLE 10TH ST #5129
JEFFERSONVILLE, IN, 47130

DATE: 2/29/2024

DWG.#:
6648433

DRAWN BY: JMB-40

SCALE:
3/4" = 1'-0"

MASTER DRAWING

SHEET NO.
1



REVISIONS

DESCRIPTION	DATE



CAPTIVE
Highwoods Group
www.captive.com
4641 Paragon Park Rd., Raleigh, NC, 27616 PHONE: (919) 875 - 0420 FAX: 9198760577 EMAIL: reg40@captive.com

CHIPOTLE JEFFERSONVILLE 10TH ST #5129
JEFFERSONVILLE, IN, 47130

DATE: 2/29/2024

DWG.#:
6648433

DRAWN BY: JMB-40

SCALE:
3/4" = 1'-0"

MASTER DRAWING

SHEET NO.
2

FIRE SYSTEM INFORMATION - JOB#6648433

FIRE SYSTEM NO	TAG	TYPE	SIZE	MAX FP	DESIGN FP	INSTALLATION	
						SYSTEM	LOCATION ON HOOD
1		TANK FS	4.0/4.0	40	32	FIRE CABINET RIGHT	RIGHT, HOOD 1

GAS VALVE(S)

FIRE SYSTEM NO	TAG	TYPE	SIZE	SUPPLIED BY
1		SC ELECTRICAL	1.500	CAPTIVEAIR SYSTEMS

FIRE SYSTEM PARTS LIST KEY

FIRE SYSTEM NO	TAG	KEY NUMBER - PART DESCRIPTION	QTY BY FACTORY	QTY BY DIST
		0 - 0 - TANK FIRE SUPPRESSION POST-DISCHARGE PROCEDURE UTILITY CABINET LABEL SHEET.	1	0
		0 - 0 - TANK FIRE SUPPRESSION MAINTENANCE GUIDE UTILITY CABINET LABEL SHEET.	1	0
		0 - 0 - 12-F28021-32144-0T-360 DUCT FIRE THERMOSTAT WITH 12 FOOT WIRE LEADS. NO, CLOSE ON TEMP RISE AT 360°F.	1	0
		0 - 0 - 32-00002 QUIK SEAL - 1/2" (UL).	1	0
		0 - 0 - 4429K153 1/2" MALE NPT TO 1/2" FEMALE NPT ELBOW, BRASS.	2	0
		0 - 0 - 4429K422 1/2" X 1/4" BRASS REDUCING BUSHING.	1	0
		0 - 0 - 79525 1/2" 90 PRO-PRESS ELBOW WITH 1/2" NPT FEMALE CONNECTION, VIEGA.	1	0
		0 - 0 - 79580 1/2" X 1/2" PRO-PRESS TEE X 1/2" NPT FEMALE CONNECTION, VIEGA.	2	0
		0 - 0 - 87-120042-001 SECONDARY ACTUATOR VALVE (SVA) - SINGLE ACTUATOR, REQUIRES PRIMARY RELEASE ACTUATOR, TANK FIRE SUPPRESSION.	1	0
		0 - 0 - 87-120045-001 HOSE, SECONDARY ACTUATOR HOSE, 7.5' BRAIDED STAINLESS STEEL, TANK FIRE SUPPRESSION.	1	0
		0 - 0 - 87-300001-001 TANK - PRESSURIZED TANK USED FOR TANK FIRE SUPPRESSION.	2	0
		0 - 0 - 87-300030-001 PRIMARY ACTUATOR KIT (PAK) - ACTUATOR AND RELEASE SOLENOID ASSEMBLY, ONE NEEDED PER FIRE SYSTEM, SUPERVISED, TANK FIRE SUPPRESSION.	1	0
		0 - 0 - 87-300152-001 HARDWARE, SVA BOLTS, TANK FIRE SUPPRESSION.	8	0
		0 - 0 - 9055455PC PRO PRESS 1/2 PRESS X PRESS 90 ELBOW LD.	7	0
		0 - 0 - 9097200PC PRO PRESS PC611 1/2 PRESS TEE LD.	7	0
		0 - 0 - 98694A115 HARDWARE, DATANKLOCK LOCKING BRACKET SQUARE NUTS 5/16" ZINC, TANK FIRE SUPPRESSION.	4	0
		0 - 0 - A0034332 JUNCTION BOX FOR MANUAL PULL STATION. 1.5" DEEP BACK BOX, RED COLOR.	1	0
		0 - 0 - A31484 1/4" NPT SCHRADER VALVE AND CAP, JB INDUSTRIES. 1/4" FLARE X 1/4" MPT HALF UNION. USED ON TANK SERVICE PORT.	1	0
		0 - 0 - B1145 3/8" BLACK IRON 90 ELL.	3	0
		0 - 0 - DATANKLOCK DISCHARGE ADAPTER TANK LOCKING PLATE FOR FIRE SYSTEM TANK INSTALLATION IN UTILITY CABINETS, TANK FIRE SUPPRESSION.	2	0
		0 - 0 - TANK STRAP TANK STRAP - USED FOR TANK FIRE SUPPRESSION.	6	0
		0 - 0 - TFS-UCTANKBRACKET TANK BRACKET FOR FIRE SYSTEM TANK INSTALLATION IN UTILITY CABINETS, TANK FIRE SUPPRESSION.	2	0
		0 - 0 - WK-283952-000 DISCHARGE ADAPTER, TANK FIRE SUPPRESSION.	2	0
		16 - 16 - 79210 1/2" X 3/8" NPT MALE ADAPTER, VIEGA.	8	0
		16 - 16 - DL-F NOZZLE - TANK PROTECTION APPLIANCE COVERAGE NOZZLE (INCLUDES METAL BLOW OFF CAP, LANYARD, USED WITH CHROME-PLATED PIPE).	8	0
		26 - 26 - QSA-3/8 QUIK SEAL - 3/8" (UL).	8	0
		34 - 34 - A0034331 24VDC SINGLE ACTION MANUAL ACTUATION DEVICE (PUSH/PULL STATION) WITH PROTECTIVE COVER, ONE (1) NORMALLY OPEN CONTACT. RED COLOR.	1	0

REVISIONS

DESCRIPTION	DATE:

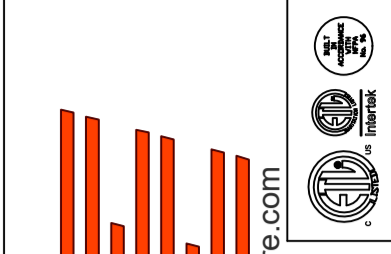

CAPTIVE FIRE
 Highwoods Group
 4641 Paragon Park Rd., Raleigh, NC, 27616 PHONE: (919) 875-0420 FAX: 9198750577 EMAIL: reg40@captivefire.com

CHIPOTLE JEFFERSONVILLE 10TH ST #5129
 JEFFERSONVILLE, IN, 47130

DATE: 2/29/2024

DWG.#:
6648433

DRAWN BY: JMB-40

SCALE:
3/4" = 1'-0"

MASTER DRAWING

SHEET NO.
3

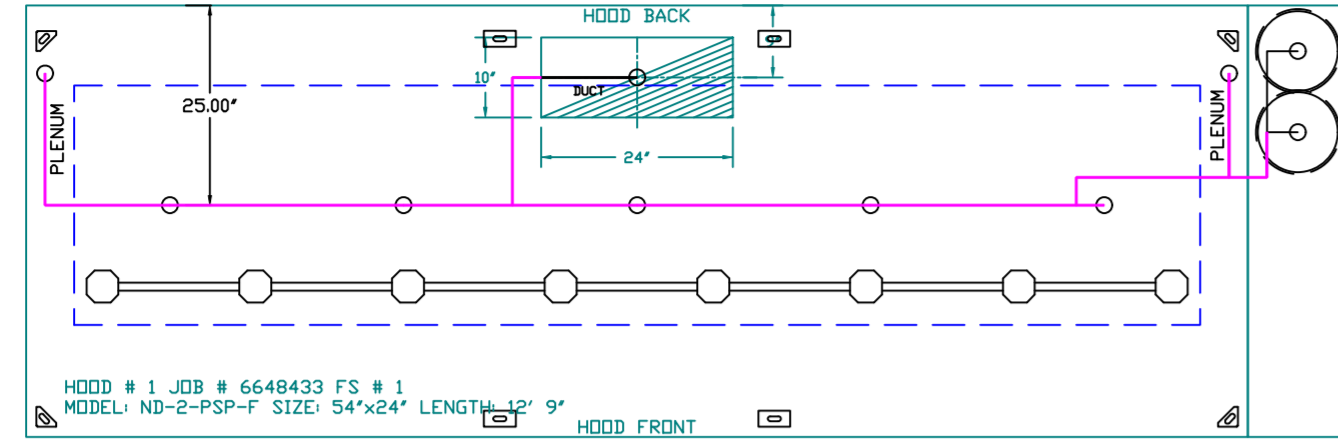

SYSTEM REQUIRES A MINIMUM OF 7 FT. OF EQUIVALENT PIPE LENGTH BETWEEN TANK AND NEAREST APPLIANCE NOZZLE FOR MOST APPLIANCES. EACH 90 DEGREE ELBOW ADDS 1.5 FT. OF EQUIVALENT LENGTH. SEE MANUAL FOR DETAILS.

- NOTES
- FIELD PIPE DROPS AS SHOWN
 - PIPING, ELBOWS, TEES, AND NOZZLES SUPPLIED BY CAS.
 - FIELD INSTALLED DROP: FACTORY WILL PROVIDE QTY 2 60IN LONG PIECES OF CHROME PLATED PIPING SHIPPED LOOSE TO BE FIELD-INSTALLED.
 - SHIP LOOSE DROP: FACTORY WILL PROVIDE THE EXACT CHROME PIPE LENGTH NEEDED SHIPPED LOOSE TO BE FIELD-INSTALLED.
 - RELOCATE NOZZLES IF FLOW PATTERN IS BLOCKED BY SHELVEING, SALAMANDERS, ETC.
 - OVERLAPPING COVERAGE SHALL NOT BE USED ON ANY APPLIANCE WITH AN OBSTRUCTION.
 - IF APPLICABLE, EXTENDED PRE-PIPED DROPS ARE SHIPPED LOOSE.
 - FACTORY PIPING EXTENDS A MAXIMUM OF 6" ABOVE THE TOP OF THE HOOD.

- APPLIANCE DIMENSIONS LISTED REPRESENT THE COOKING SURFACE SIZE, NOT THE OVERALL APPLIANCE SIZE.
- THIS FIRE SYSTEM COMPLIES WITH UL 300 REQUIREMENTS.

- DL-F NOZZLE PART NUMBER REPLACES 3070-3/8H-10-SS

JOB #: 6648433
JOB NAME: CHIPOTLE JEFFERSONVILLE 10TH ST #5129.

SYSTEM SIZE: TANK-SP-2 DESIGN FP: 32. MAXIMUM FP: 40.
HOOD # 1 12' 9.00" LONG X 54" WIDE X 24" HIGH.
RISER # 1 SIZE: 10" X 24".
HOOD # 1 METAL BLOW-OFF CAPS INCLUDED.

- HEAVY-DUTY APPLIANCES (RATED 600°F) WILL REQUIRE AN ADDITIONAL DOWNSTREAM FIRESTAT IN THE EVENT THAT THE DUCTWORK CONTAINS ANY HORIZONTAL RUNS OVER 25 FT IN LENGTH.
- MEDIUM TO LIGHT-DUTY APPLIANCES (RATED 450°F) WILL NOT REQUIRE ANY ADDITIONAL DOWNSTREAM DETECTION.

LEGEND - FIRE CABINET TANK SYSTEM

- 4 GALLON TANK.
- PRIMARY ACTUATOR RELEASE.
- SECONDARY ACTUATOR RELEASE.
- PRESSURE SUPERVISION SWITCH.
- PRIMARY HOSE ASSEMBLY.
- SECONDARY HOSE ASSEMBLY.
- REMOTE MANUAL ACTUATION DEVICE.

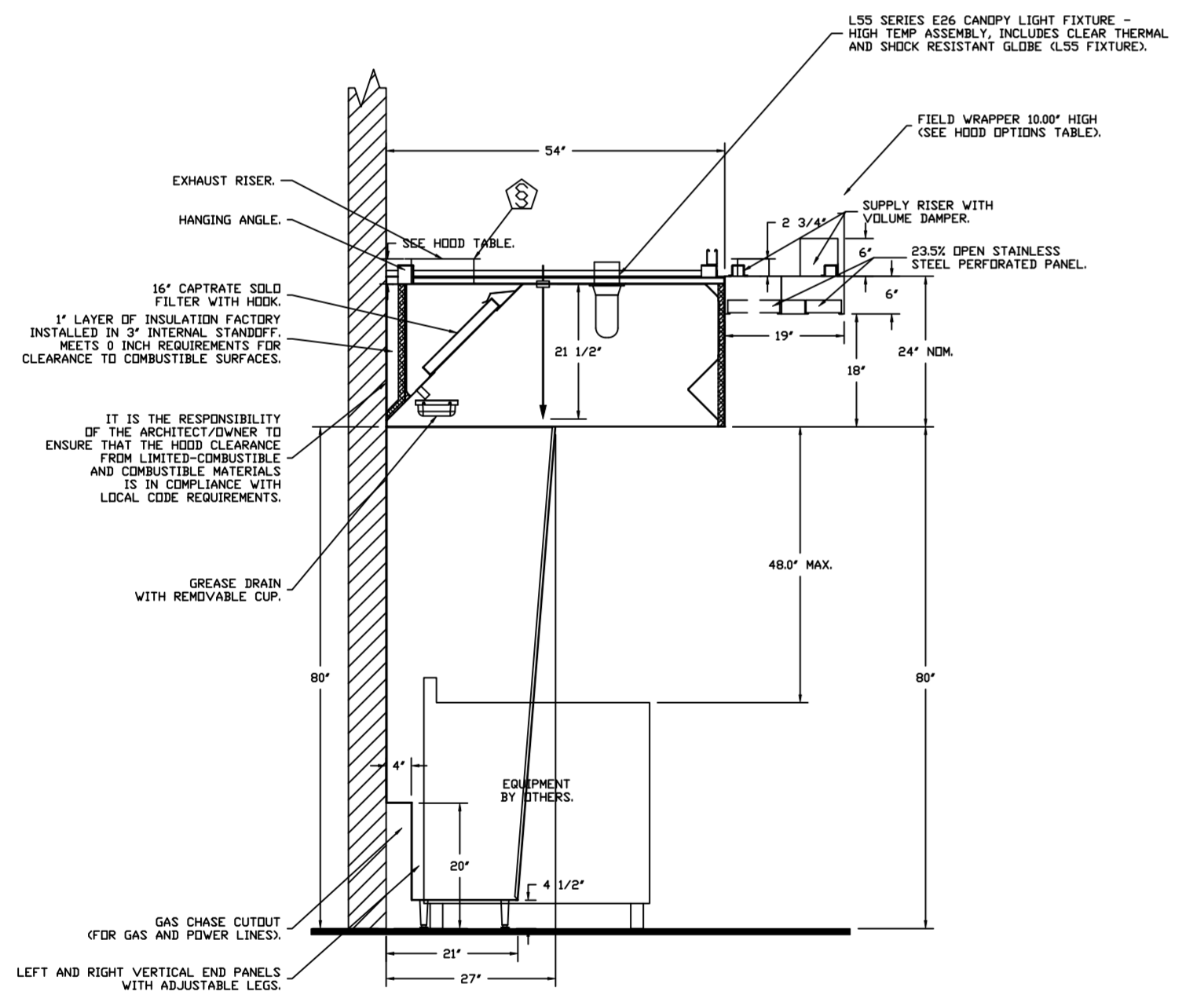
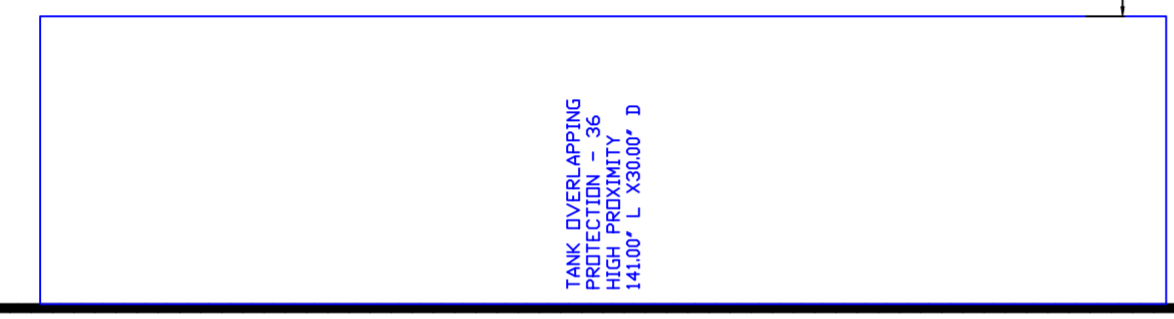
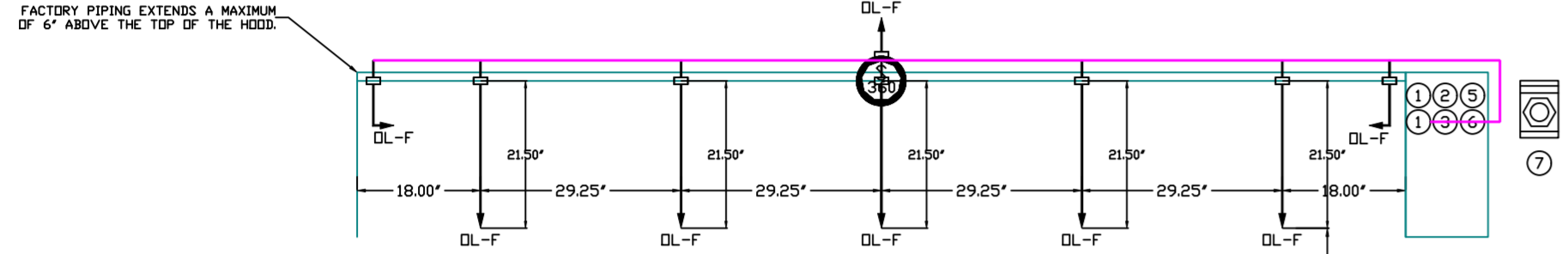

GAS VALVES AND STRAINERS															
TYPE	SIZE	VOLTAGE	GAS VALVE SIZING			GAS VALVE DIMENSIONS						INSTALLATION	PART NUMBERS		
			MIN. INLET PRESSURE (0 IN.W.C.)	MAX. INLET PRESSURE (5 PS)	FLOW AT 1 IN.W.C. DROP NATURAL GAS (2,406,000 BTU/HR)	DIM "A"	DIM "B"	DIM "C"	DIM "D"	DIM "E"	DIM "F"		DIM "G"	MOUNTING ORIENTATION	GAS VALVE PART NUMBER
ELECTRICAL	1-1/2"	24 VDC	0 PS	5 PS	2,406,000 BTU/HR	7-5/8"	6-3/8"	5-3/4"	6-3/16"	14-1/8"	12-5/16"	HORIZONTAL	R214275-24VDC	4417K67	(SC)EJVC1-1/2-24

ALL GAS VALVES/STRAINERS PROPER CLEARANCE MUST BE PROVIDED IN ORDER TO SERVICE THE STRAINERS A MINIMUM OF 4" CLEARANCE DISTANCE MUST BE PROVIDED AT THE BASE OF THE STRAINER. CUSTOMER MUST VERIFY BTU CONSUMPTION AS WELL AS PRESSURE RATING SPECIFIC GRAVITY OF NATURAL GAS = 0.64, SPECIFIC GRAVITY OF LP = 1.52.

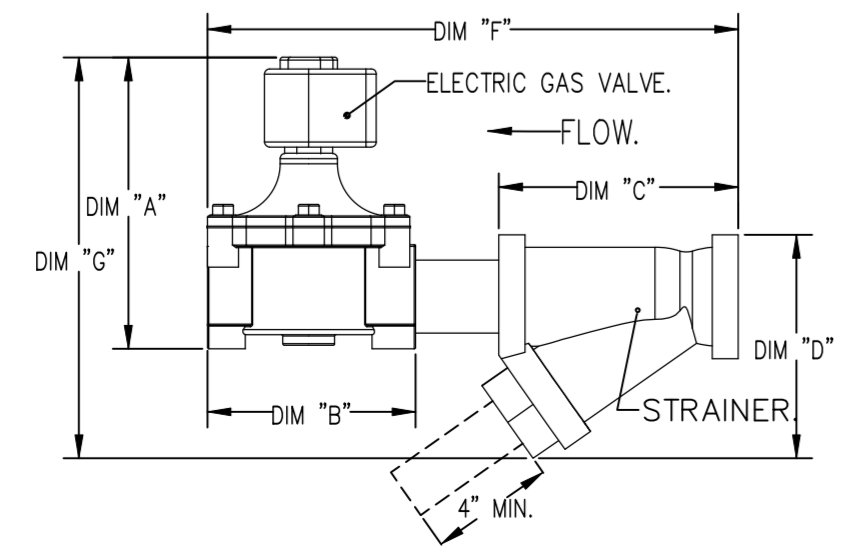

INCLUDES: FIELD INSTALLATION AND HOOKUP DURING NORMAL BUSINESS HOURS BY CERTIFIED INSTALLERS ONLY IN THE LOCATION NOTED ABOVE. TWO SITE VISITS ONLY (ONE VISIT TO SET PULL STATION & SYSTEM HOOKUP AND ONE VISIT FOR ONE TEST). ADDITIONAL VISITS WILL RESULT IN ADDITIONAL CHARGES. ONE MECHANICAL OR ELECTRICAL GAS VALVE PER SYSTEM AT A MAXIMUM SIZE OF 2". PERMIT, AND SYSTEM TEST. EXCLUDES: UNION LABOR & PREVAILING WAGE (LABOR & WAGES WILL BE ADDED IF APPLICABLE), GAS VALVE INSTALLATION, ELECTRICAL HOOKUP AND CONNECTIONS, HANGING OF FIRE CABINET, SHUNT TRIP, HANDHELD EXTINGUISHERS, ON-SITE RE-PIPING DUE TO EQUIPMENT LAYOUT CHANGES.

REVISIONS

DESCRIPTION	DATE:

CAPTIVE

Highwoods Group

www.captivefire.com

4841 Paragon Park Rd., Raleigh, NC, 27616 PHONE: (919) 875 - 0420 FAX: 9198760577 EMAIL: reg40@captivefire.com

CHIPOTLE JEFFERSONVILLE 10TH ST #5129
JEFFERSONVILLE, IN, 47130

DATE: 2/29/2024
DWG.#: 6648433
DRAWN BY: JMB-40
SCALE: 1/2" = 1'-0"
MASTER DRAWING

SHEET NO. 4

EXHAUST FAN INFORMATION - JOB#6648433

FAN UNIT NO	TAG	QTY	FAN UNIT MODEL #	MANUFACTURER	CFM	ESP	RPM	MOTOR ENCL	HP	BHP	PHASE	VOLT	FLA	DISCHARGE VELOCITY	WEIGHT (LBS)	SDNES
1	EF-1	1	DUI80HFA	CAPTIVEAIRE	2550	1.450	1226	DDP,PREMIUM	2.000	1.2780	3	208	8.3	589 FPM	183	16.8
2	EF-2	1	DR12HFA	CAPTIVEAIRE	150	0.600	1293	TEAD-ECM	0.250	0.0950	1	115	2.9		50	6.2

MUA FAN INFORMATION - JOB#6648433

FAN UNIT NO	TAG	QTY	FAN UNIT MODEL #	BLOWER	HOUSING	MIN CFM	DESIGN CFM	ESP	RPM	MOTOR ENCL	HP	BHP	PHASE	VOLT	FLA	MCA	MOCP	WEIGHT (LBS)	SDNES
3	MAU-1	1	A1-D.250-15D	15MF-1-MDD	A1-D.250	1000	1300	0.500	1553	DDP,PREMIUM	1.000	0.5660	3	208	3.1	3.9A	15A	494	12.2

GAS FIRED MAKE-UP AIR UNIT(S)

FAN UNIT NO	TAG	INPUT BTUs	OUTPUT BTUs	TEMP RISE	REQUIRED INPUT GAS PRESSURE	GAS TYPE	BURNER EFFICIENCY(%)
3	MAU-1	88922	81808	60°F	7 IN. W.C. - 14 IN. W.C.	NATURAL	92

FAN #1 DUI80HFA - EXHAUST FAN (EF-1)

FAN OPTIONS

FAN UNIT NO	TAG	QTY	DESCRIPTION
1	EF-1	1	GREASE BOX
		1	2 YEAR PARTS WARRANTY
2	EF-2	1	1 12-BDD DAMPER
		1	ECM WIRING PACKAGE - MANUAL OR 0-10VDC REFERENCE SPEED CONTROL -RTC- (TELCO MOTOR), CCW ROTATION
3	MAU-1	1	2 YEAR PARTS WARRANTY
		1	SIZE 1 TEMPERED COMMERCIAL DOWN DISCHARGE FOR DIRECT DRIVE AHUS
		1	INLET PRESSURE GAUGE, 0-35"
		1	MANIFOLD PRESSURE GAUGE, -5 TO 15" WC
		1	SHIP LOOSE GAS STRAINER 3/4"
		1	MOTORIZED BACKDRAFT DAMPER FOR A1-D HOUSING - MEETS AMCA CLASS 1A RATING
		1	SEPARATE 120V WIRING PACKAGE (REQUIRED AND USED ONLY FOR DCV OR PREWIRE WITH VFD) - THREE PHASE ONLY
1	2 YEAR PARTS WARRANTY		

FAN ACCESSORIES

FAN UNIT NO	TAG	EXHAUST				SUPPLY			
		GREASE CUP	GRAVITY DAMPER	WALL MOUNT	SIDE DISCHARGE	GRAVITY DAMPER	MOTORIZED DAMPER	WALL MOUNT	
1	EF-1	YES							
2	EF-2		YES						
3	MAU-1						YES		

CURB ASSEMBLIES

NO	ON FAN	TAG	WEIGHT	ITEM	SIZE
1	# 1	EF-1	39 LBS	CURB	26.500"W X 26.500"L X 20.000"H VENTED.
2	# 2	EF-2	31 LBS	CURB	17.500"W X 17.500"L X 26.000"H.
3	# 3	MAU-1	65 LBS	CURB	21.000"W X 71.000"L X 20.000"H INSULATED.

HMI SCHEDULE					
UNIT NUMBER	HMI #		HMI LOCATION	TEMP AVERAGING	MODBUS ADDRESS
FAN #3	HMI #1 - UNIT	HMI # 1	MOUNTED IN UNIT	NOT AVERAGED	55

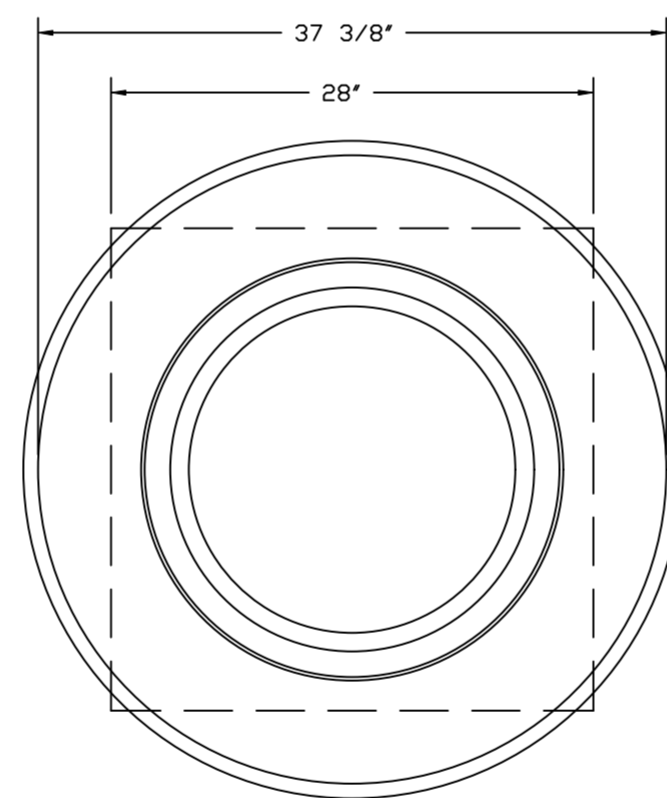
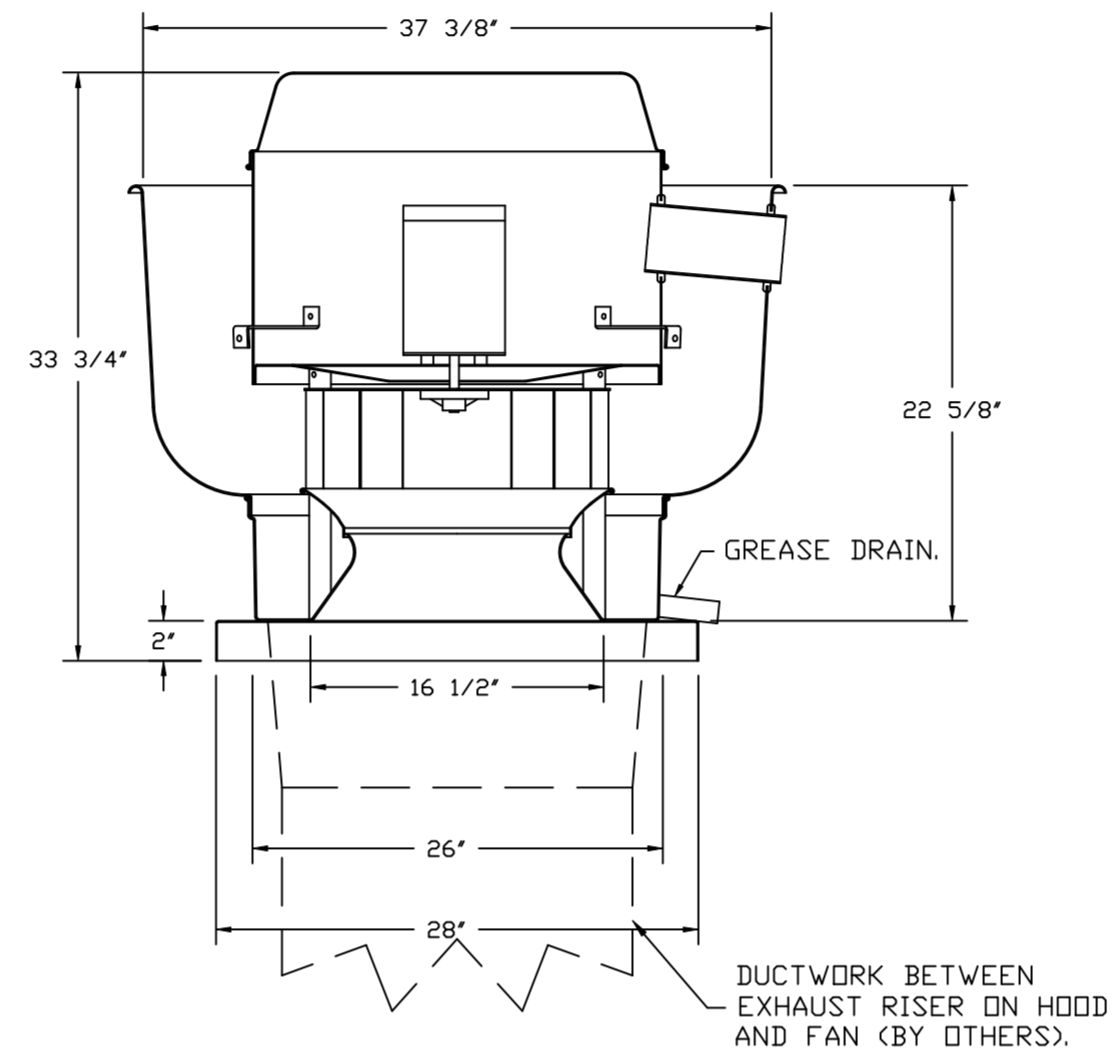

TOP VIEW

FEATURES:

- DIRECT DRIVE CONSTRUCTION (NO BELTS/PULLEYS).
- ROOF MOUNTED FANS.
- RESTAURANT MODEL.
- UL705 AND UL762 AND ULC-S645
- VARIABLE SPEED CONTROL.
- INTERNAL WIRING.
- THERMAL OVERLOAD PROTECTION (SINGLE PHASE).
- HIGH HEAT OPERATION 300°F (149°C).
- GREASE CLASSIFICATION TESTING.
- NEMA 3R SAFETY DISCONNECT SWITCH.

NORMAL TEMPERATURE TEST

EXHAUST FAN MUST OPERATE CONTINUOUSLY WHILE EXHAUSTING AIR AT 300°F (149°C) UNTIL ALL FAN PARTS HAVE REACHED THERMAL EQUILIBRIUM, AND WITHOUT ANY DETEIORATING EFFECTS TO THE FAN WHICH WOULD CAUSE UNSAFE OPERATION.

ABNORMAL FLARE-UP TEST

EXHAUST FAN MUST OPERATE CONTINUOUSLY WHILE EXHAUSTING BURNING GREASE VAPORS AT 600°F (316°C) FOR A PERIOD OF 15 MINUTES WITHOUT THE FAN BECOMING DAMAGED TO ANY EXTENT THAT COULD CAUSE AN UNSAFE CONDITION.

OPTIONS

- GREASE BOX.
- 2 YEAR PARTS WARRANTY.

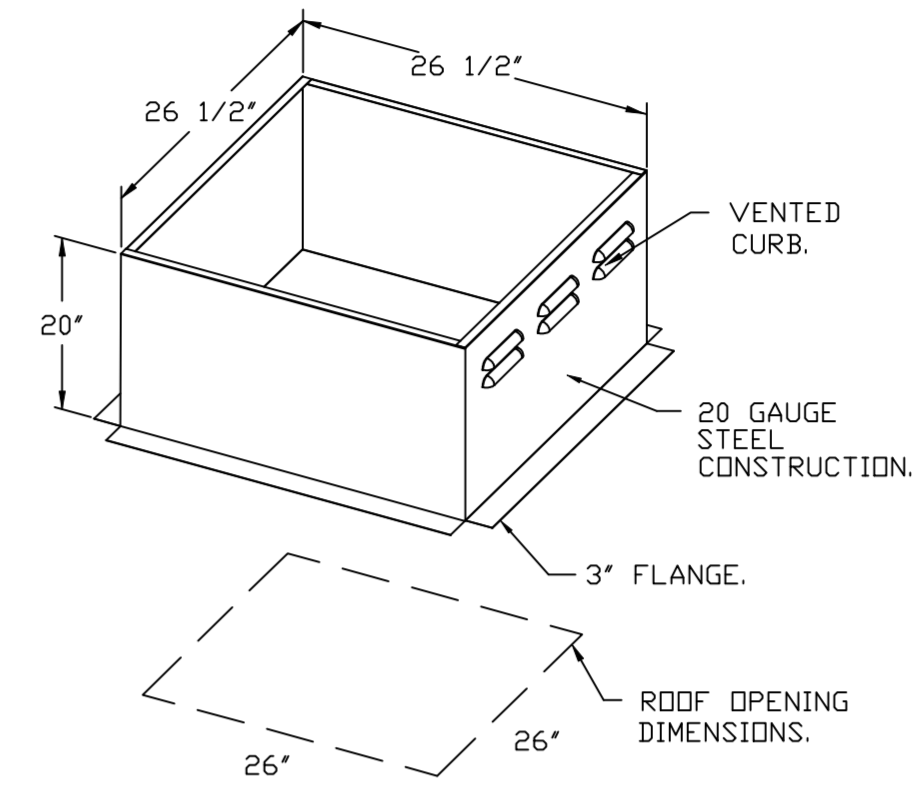

REVISIONS

DESCRIPTION	DATE

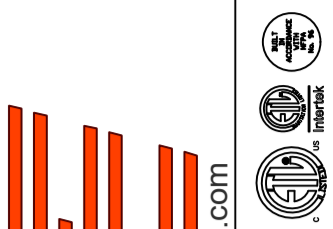

CAPTIVE AIR
Highwoods Group
www.captiveaire.com
4641 Paragon Park Rd., Raleigh, NC, 27616 PHONE: (919) 875 - 0420 FAX: 9198760577 EMAIL: reg4@captiveaire.com

CHIPOTLE JEFFERSONVILLE 10TH ST #5129
JEFFERSONVILLE, IN, 47130

DATE: 2/29/2024

DWG.#: 6648433

DRAWN BY: JMB-40

SCALE: 3/4" = 1'-0"

MASTER DRAWING

SHEET NO.

FAN #2 DR12HFA - EXHAUST FAN (CF-22)

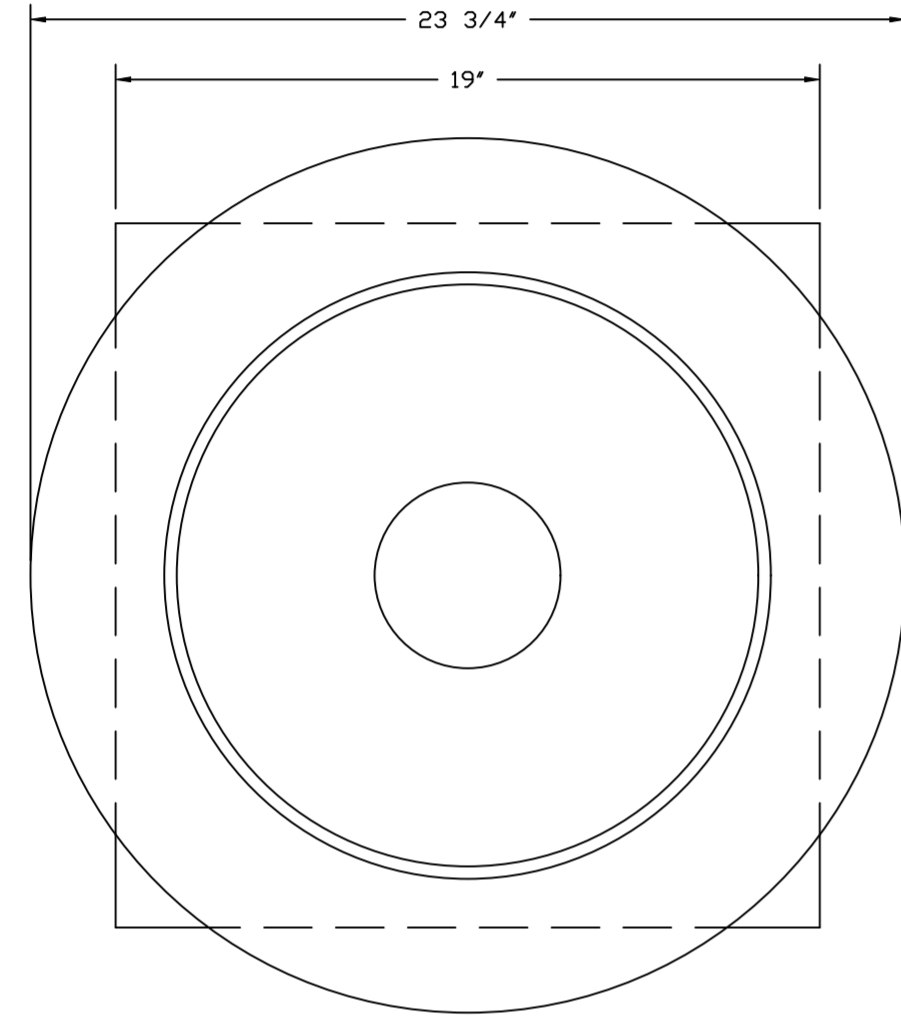

TOP VIEW

FEATURES:

- DIRECT DRIVE CONSTRUCTION (NO BELTS/PULLEYS).
- ROOF MOUNTED FANS.
- UL705.
- SAFETY DISCONNECT.
- STANDARD BIRD SCREEN.
- SPEED CONTROL.
- THERMAL OVERLOAD PROTECTION (SINGLE PHASE).

OPTIONS:

- I 12-BDD DAMPER.
- ECM WIRING PACKAGE - MANUAL OR 0-10VDC REFERENCE SPEED CONTROL.
- RTC - (THERM MOTOR), CCW ROTATION.
- 2 YEAR PARTS WARRANTY.

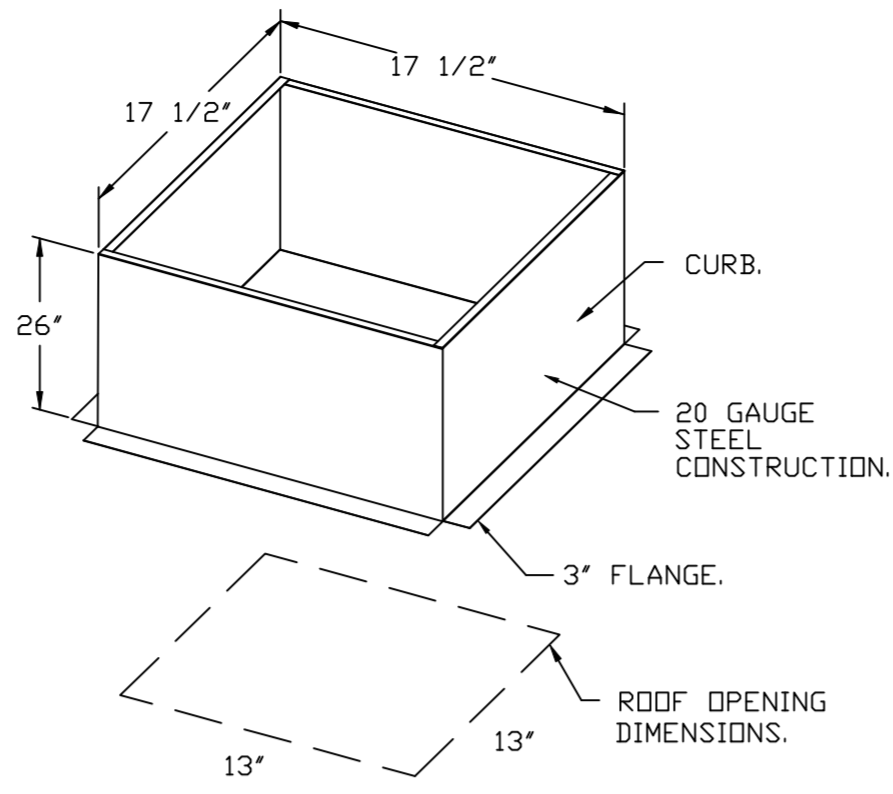

BACKDRAFT DAMPER INSTALLATION

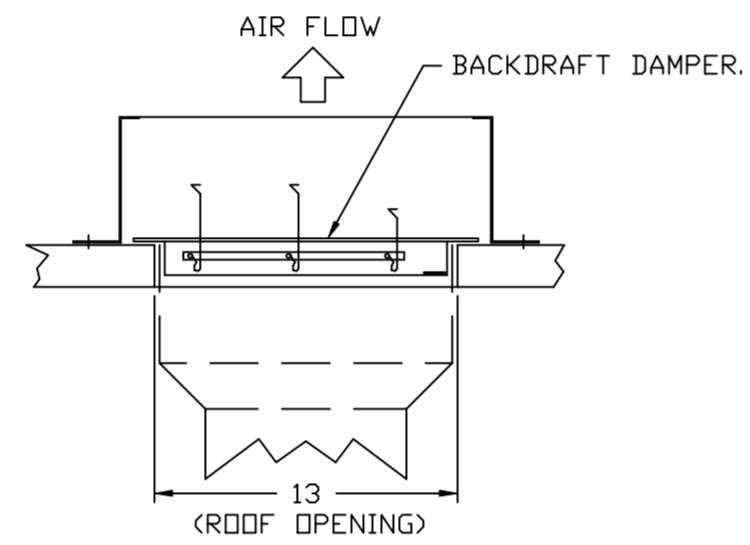

REVISIONS

DESCRIPTION	DATE:



www.captiveaire.com

Highwoods Group

4641 Paragon Park Rd., Raleigh, NC, 27616 PHONE: (919) 875 - 0420 FAX: 9198760577 EMAIL: reg40@captiveaire.com

CHIPOTLE JEFFERSONVILLE 10TH ST #5129
JEFFERSONVILLE, IN, 47130

DATE: 2/29/2024

DWG.#:
6648433

DRAWN BY: JMB-40

SCALE:
3/4" = 1'-0"

MASTER DRAWING

SHEET NO.
6

- FAN #3 A1-D250-15D - HEATER (MAU-1)
1. DIRECT GAS FIRED HEATED MAKE UP AIR UNIT WITH 15' MIXED FLOW DIRECT DRIVE FAN.
 2. INTAKE HOOD WITH EZ FILTERS.
 3. DOWN DISCHARGE - AIR FLOW RIGHT -> LEFT.
 4. DOWN DISCHARGE CONSTRUCTION FOR SIZE 1 DIRECT DRIVE AHUS.
 5. GAS PRESSURE GAUGE, 0-35", 2.5" DIAMETER, 1/4" THREAD SIZE.
 6. GAS PRESSURE GAUGE, -5 TO +15 INCHES WC, 2.5" DIAMETER, 1/4" THREAD SIZE.
 7. SHIP LOOSE GAS STRAINER, TO BE INSTALLED UPSTREAM OF UNIT CONNECTION, 3/4" CONNECTION.
 8. MOTORIZED BACK DRAFT DAMPER 16" X 18" FOR SIZE 1 STANDARD & MODULAR HEATER UNITS W/EXTENDED SHAFT, STANDARD GALVANIZED CONSTRUCTION, 3/4" REAR FLANGE, LOW LEAKAGE, TFBIDS ACTUATOR INCLUDED.
 9. SEPARATE 120VAC WIRING PACKAGE FOR MAKE-UP AIR UNITS. OPTION MUST BE SELECTED WHEN MOUNTING VFD IN PREWIRE PANEL OR WITH DCV PACKAGE. PROVIDES SEPARATE 120VAC INPUT TO SUPPLY FAN. THIS 120V SIGNAL MUST BE RUN BY ELECTRICIAN FROM DCV TO MUA SWITCH.
 10. HINGED DOUBLE WALL INSULATED DOOR ASSEMBLY (BURNER/BLOWER SECTION).
 11. 2 YEAR PARTS WARRANTY.

*NOTE: SUPPLY DUCT MUST BE INSTALLED TO MEET SMACNA STANDARDS. A MINIMUM STRAIGHT DUCT LENGTH MUST BE MAINTAINED DOWNSTREAM OF UNIT DISCHARGE AS OUTLINED IN AMCA PUBLICATION 201. WHEN USING RECTANGULAR DUCTWORK, ELBOWS MUST BE RADIUS THROAT, RADIUS BACK WITH TURNING VANES. FLEXIBLE DUCTWORK AND SQUARE THROAT/SQUARE BACK ELBOWS SHOULD NOT BE USED. ANY TRANSITION AND/OR TURNS IN THE DUCTWORK WILL CAUSE SYSTEM EFFECT. SYSTEM EFFECT WILL DRASTICALLY INCREASE STATIC PRESSURE AND REDUCE AIRFLOW. DO NOT RELY ON UNIT TO SUPPORT DUCT IN ANY WAY. FAILURE TO PROPERLY SIZE DUCTWORK MAY CAUSE SYSTEM EFFECTS AND REDUCE PERFORMANCE OF THE EQUIPMENT. SUGGESTED STRAIGHT DUCT SIZE IS 14' x 14'.

SUPPLY SIDE HEATER INFORMATION:

WINTER TEMPERATURE = 16°F. TEMP. RISE = 60°F.
 BTUS CALCULATED OFF ACTUAL AIR DENSITY.
 OUTPUT BTUS AT ALTITUDE OF 0.0 FT. = 83175.
 INPUT BTUS AT ALTITUDE OF 0.0 FT. = 90408.
 OUTPUT BTUS AT ALTITUDE OF 458 FT. = 81908.
 INPUT BTUS AT ALTITUDE OF 458 FT. = 88921.

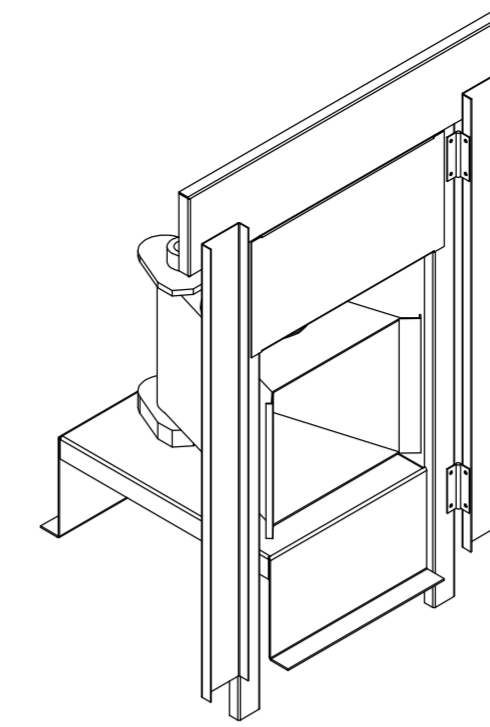

DIRECT FIRED (DF) PROFILE PLATE ASSEMBLY

DIRECT FIRED PROFILE PLATE SPECIFICATIONS:

DESCRIPTION:
 DIRECT FIRED BURNERS SHALL HAVE PATENTED (US PATENT NO. US6629523B2), SELF-ADJUSTING PROFILE PLATES DESIGNED TO ENSURE PROPER AIR VELOCITY AND PRESSURE DROP ACROSS THE BURNER. PROFILE PLATES SHALL ALLOW BURNERS TO ACHIEVE CLEAN COMBUSTION BY LIMITING BY-PRODUCT LEVELS TO A MAXIMUM OF 5PPM OF CARBON MONOXIDE (CO), AND 0.5PPM OF NITROGEN DIOXIDE (NO2). DIRECT FIRED UNITS SHALL BE CONFIGURED WITH THE BLOWER MOUNTED DOWNSTREAM OF THE BURNER. THIS ARRANGEMENT WILL ENSURE A CONSISTENT AIRFLOW, REGARDLESS OF INLET AIR TEMPERATURE.

APPLICATION:
 SPRING-LOADED BURNER PROFILE PLATES ARE ENGINEERED TO AUTOMATICALLY REACT TO THE MOMENTUM OF A FRESH AIR STREAM, WITHOUT THE NEED FOR ANY MOTORS OR ACTUATORS TO MECHANICALLY ADJUST THEM. WITH THIS FEATURE, ALL DF UNITS ARE DESIGNED FOR DEMAND CONTROL VENTILATION (DCV) REQUIREMENTS.

CERTIFICATIONS:
 ALL PROFILE PLATE ASSEMBLIES SHALL BE INCLUDED IN THE DF UNIT'S ETL LISTING AND COMPLY WITH COMBINED SAFETY STANDARDS ANSI Z83.4 AND CSA 3.7 (NDN-RECIRCULATING DF HEATERS) AND ANSI Z83.18 (RECIRCULATING DF HEATERS).

GENERAL CONSTRUCTION:

- PROFILE PLATES SHALL BE FORMED FROM G90 GALVANIZED STEEL.
- PROFILE PLATES SHALL VARY IN SIZE PER UNIT.
- PROFILE PLATES SHALL BE MOUNTED ALONG THE SAME PLANE AS THE DISCHARGE OF THE BURNER.
- DESIGN SHALL INCORPORATE PROPERLY TORQUED, PERMANENTLY MOUNTED SPRING HINGES.
- SPRING HINGES SHALL BE MADE FROM PLATED STEEL.

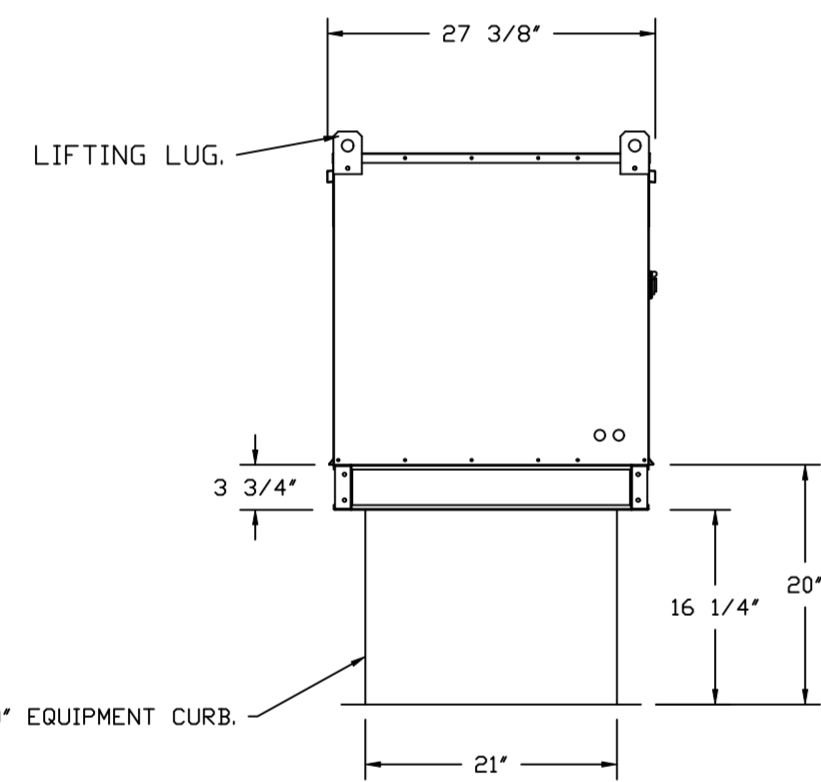
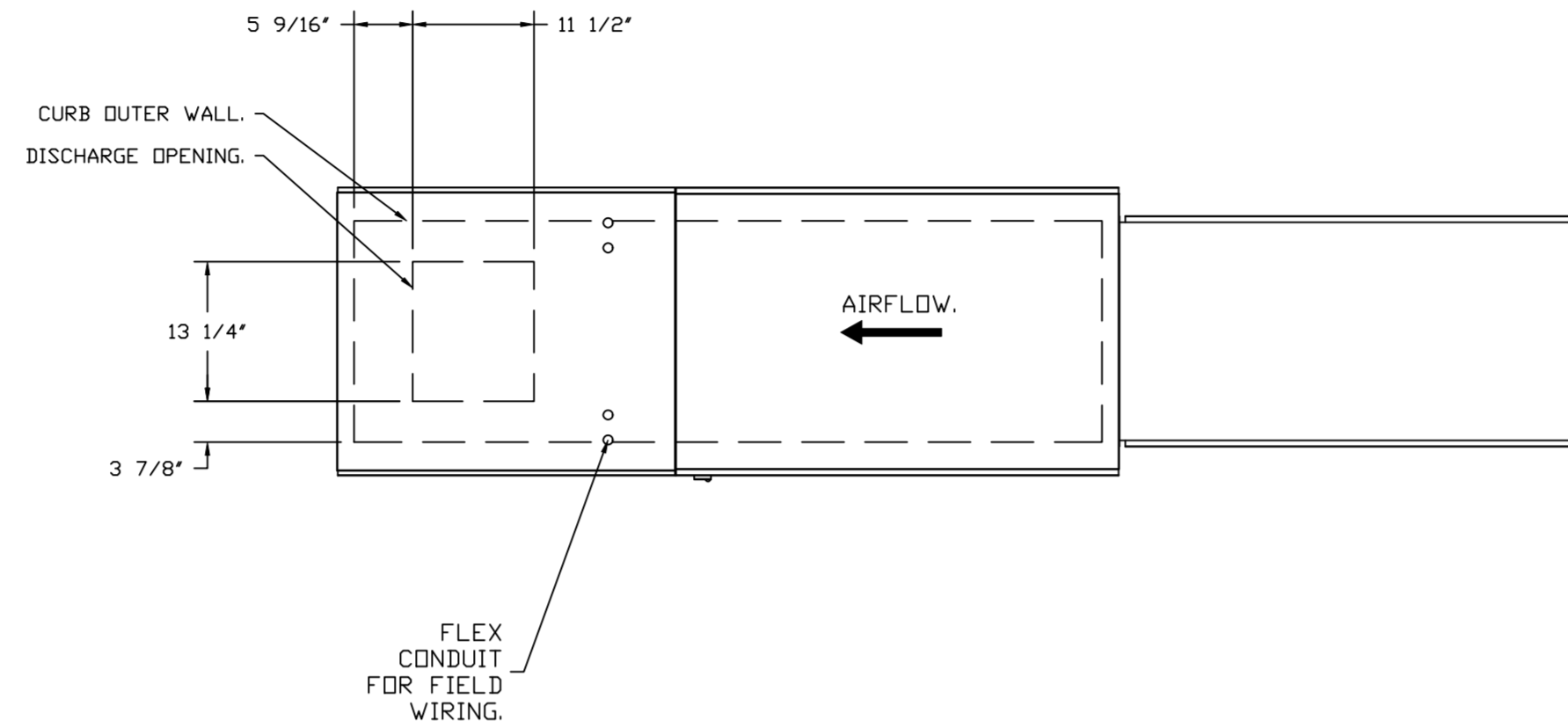

ROOF OPENING 2" SMALLER THAN CURB DIMENSION.

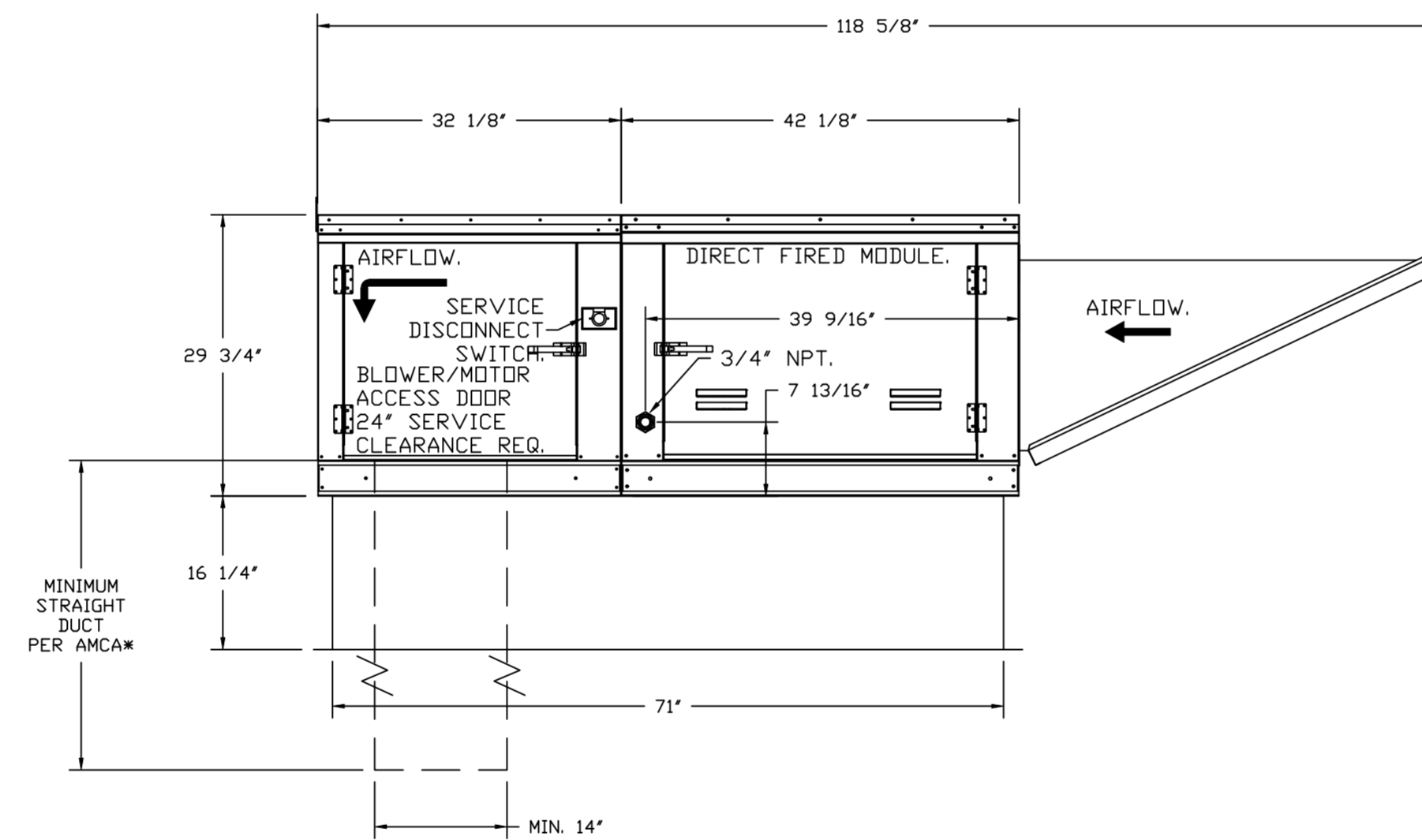

OPTIONS:
 - FULL BOTTOM CORNERS.

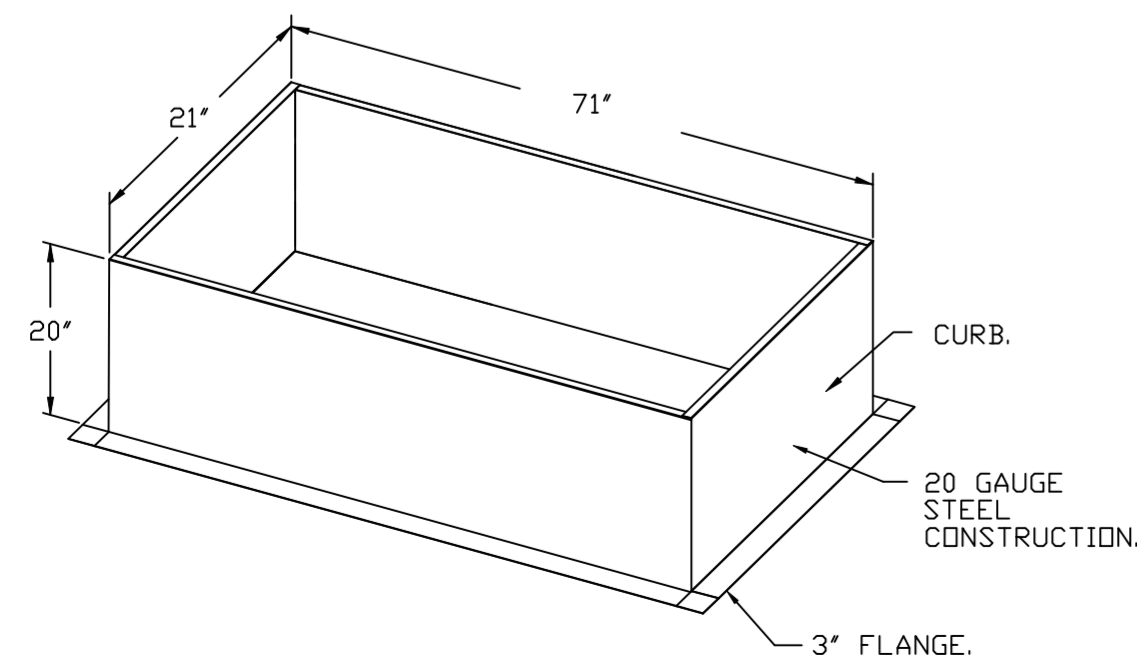

REVISIONS

DESCRIPTION	DATE

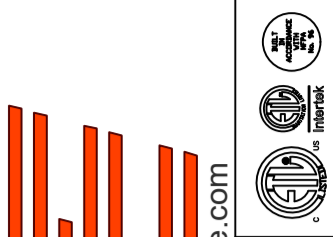

www.captiveair.com

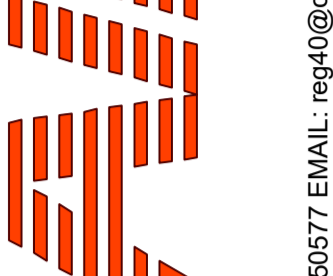

Highwoods Group

4641 Paragon Park Rd., Raleigh, NC, 27616 PHONE: (919) 875 - 0420 FAX: 9198760577 EMAIL: reg4@captivate.com

CHIPOTLE JEFFERSONVILLE 10TH ST #5129
 JEFFERSONVILLE, IN, 47130

DATE: 2/29/2024

DWG.#:
 6648433

DRAWN BY: JMB-40

SCALE:
 3/4" = 1'-0"

MASTER DRAWING

SHEET NO.

7

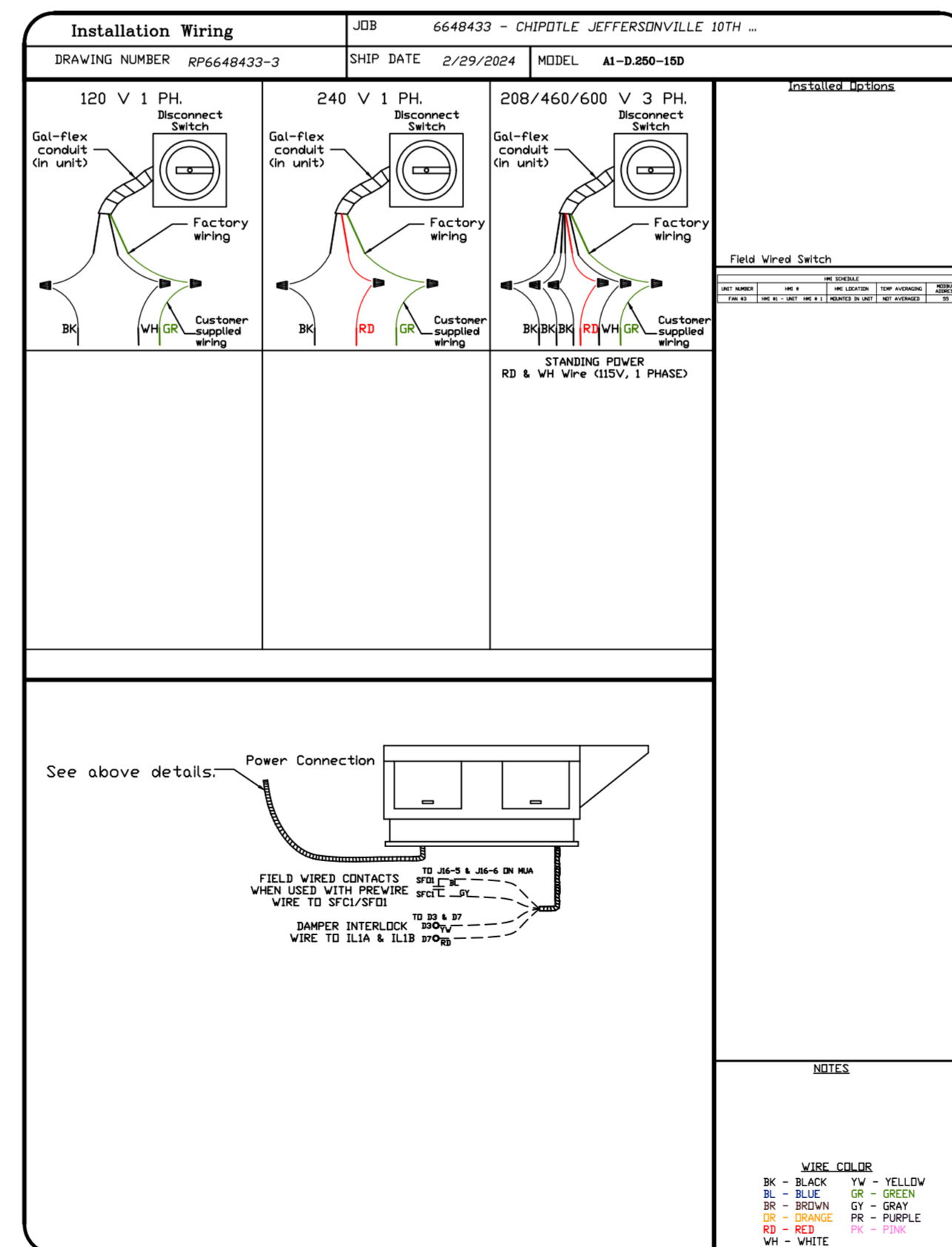
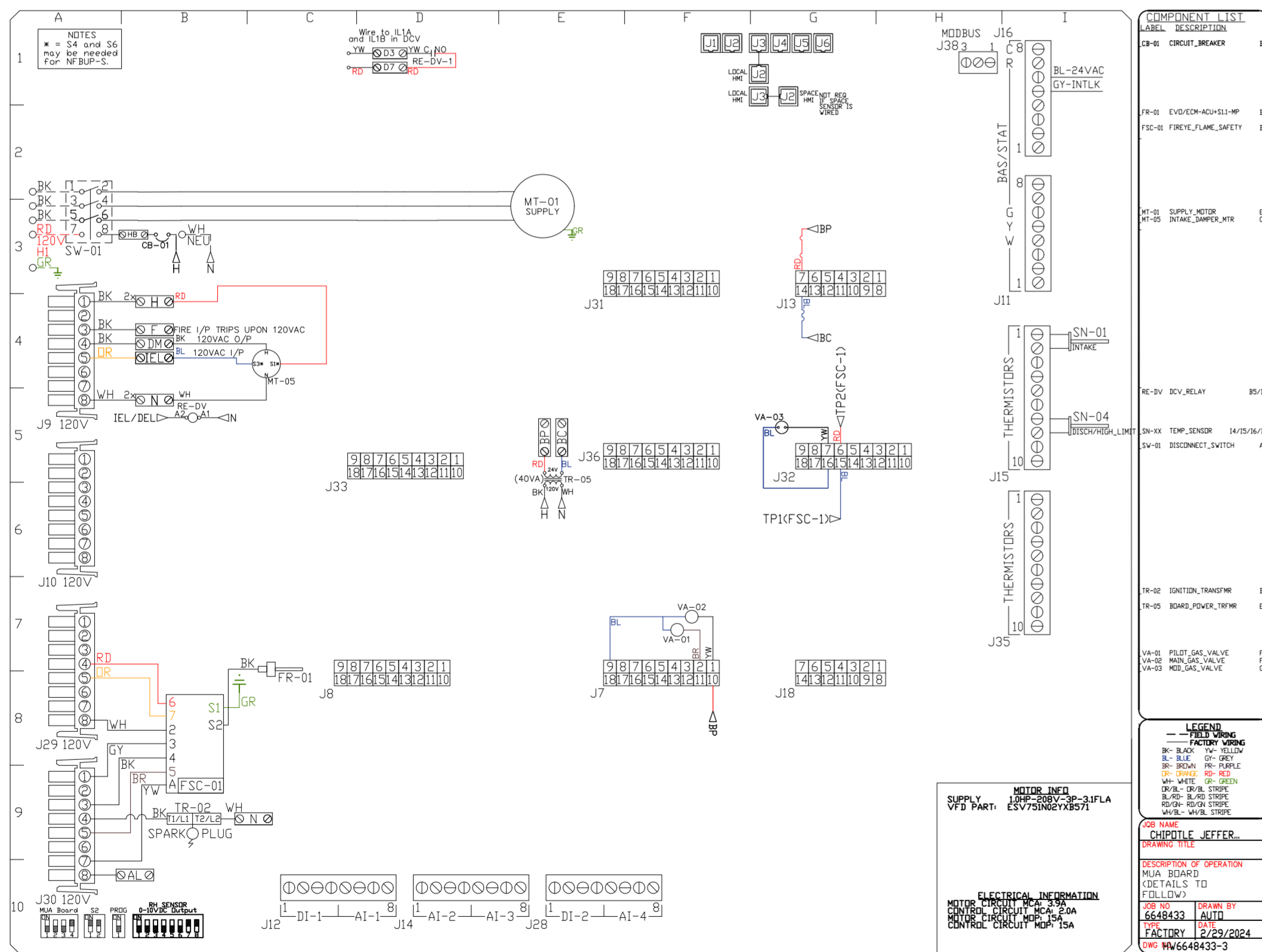
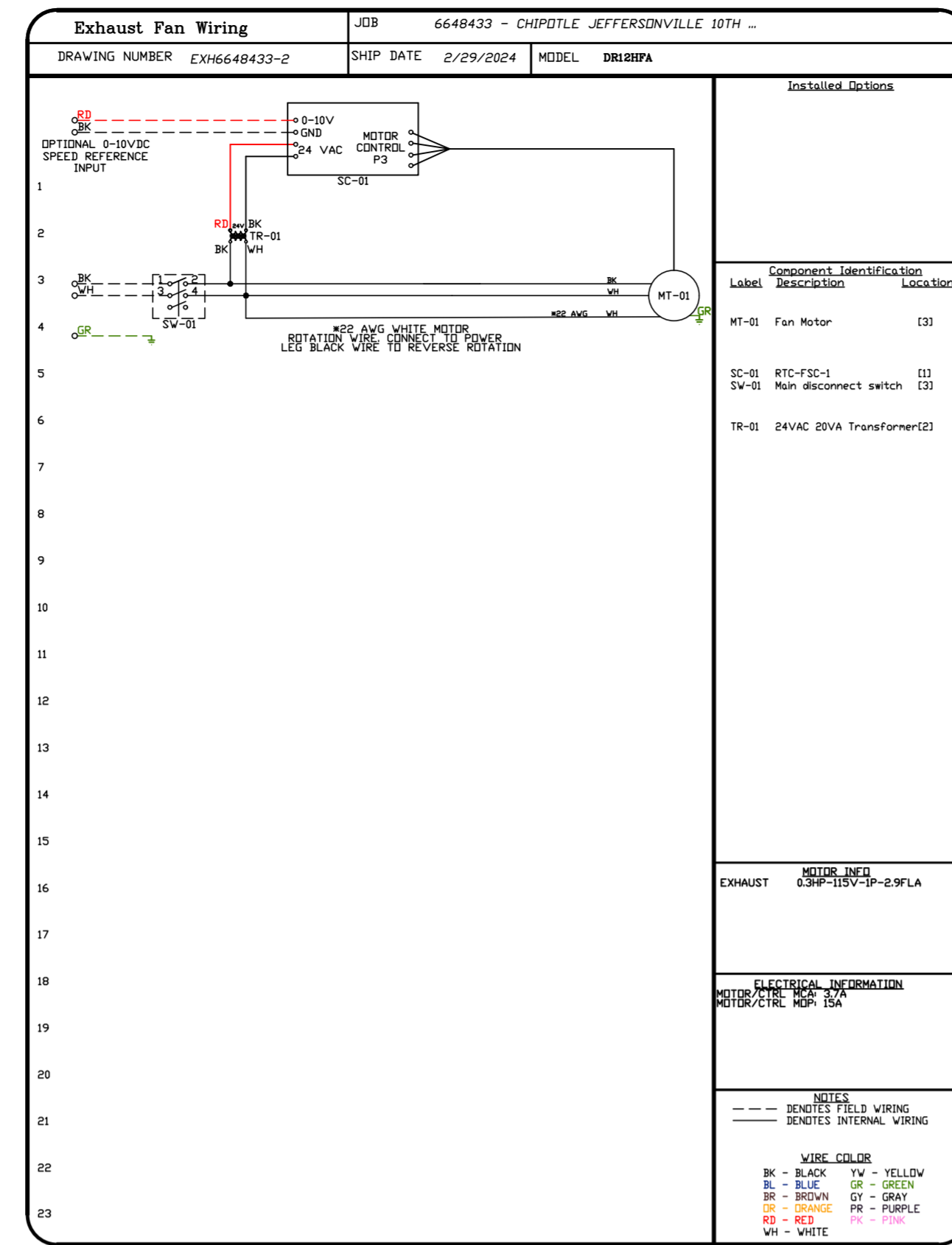
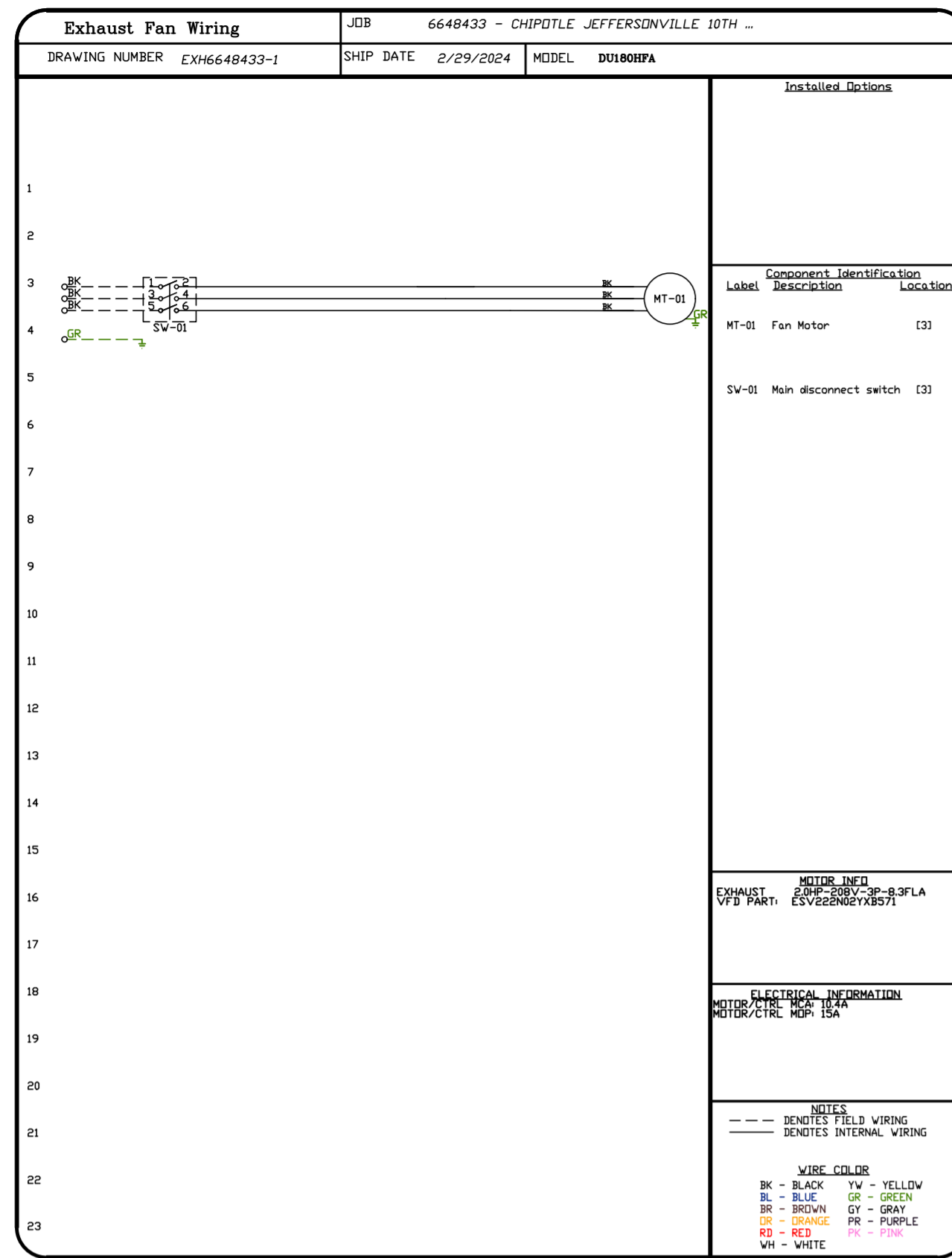

REVISIONS	
DESCRIPTION	DATE:

www.captive.com
 Highwoods Group
 4641 Paragon Park Rd., Raleigh, NC, 27616 PHONE: (919) 875 - 0420 FAX: 9198760577 EMAIL: reg40@captive.com

CHIPOTLE JEFFERSONVILLE 10TH ST #5129
JEFFERSONVILLE, IN, 47130

DATE: 2/29/2024

DWG.#:
6648433

DRAWN BY:
JMB-40

SCALE:
3/4" = 1'-0"

MASTER DRAWING

SHEET NO.
8

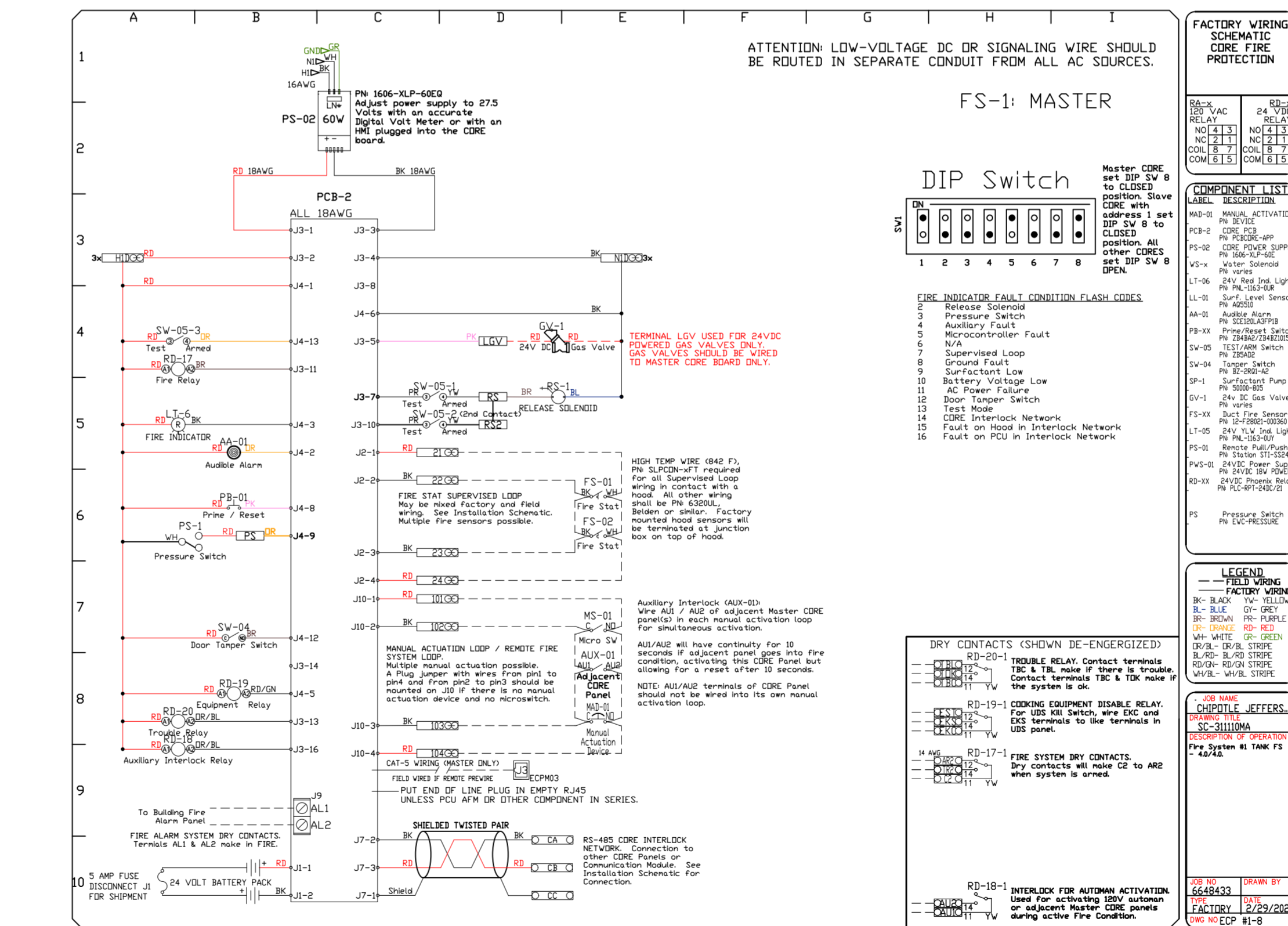
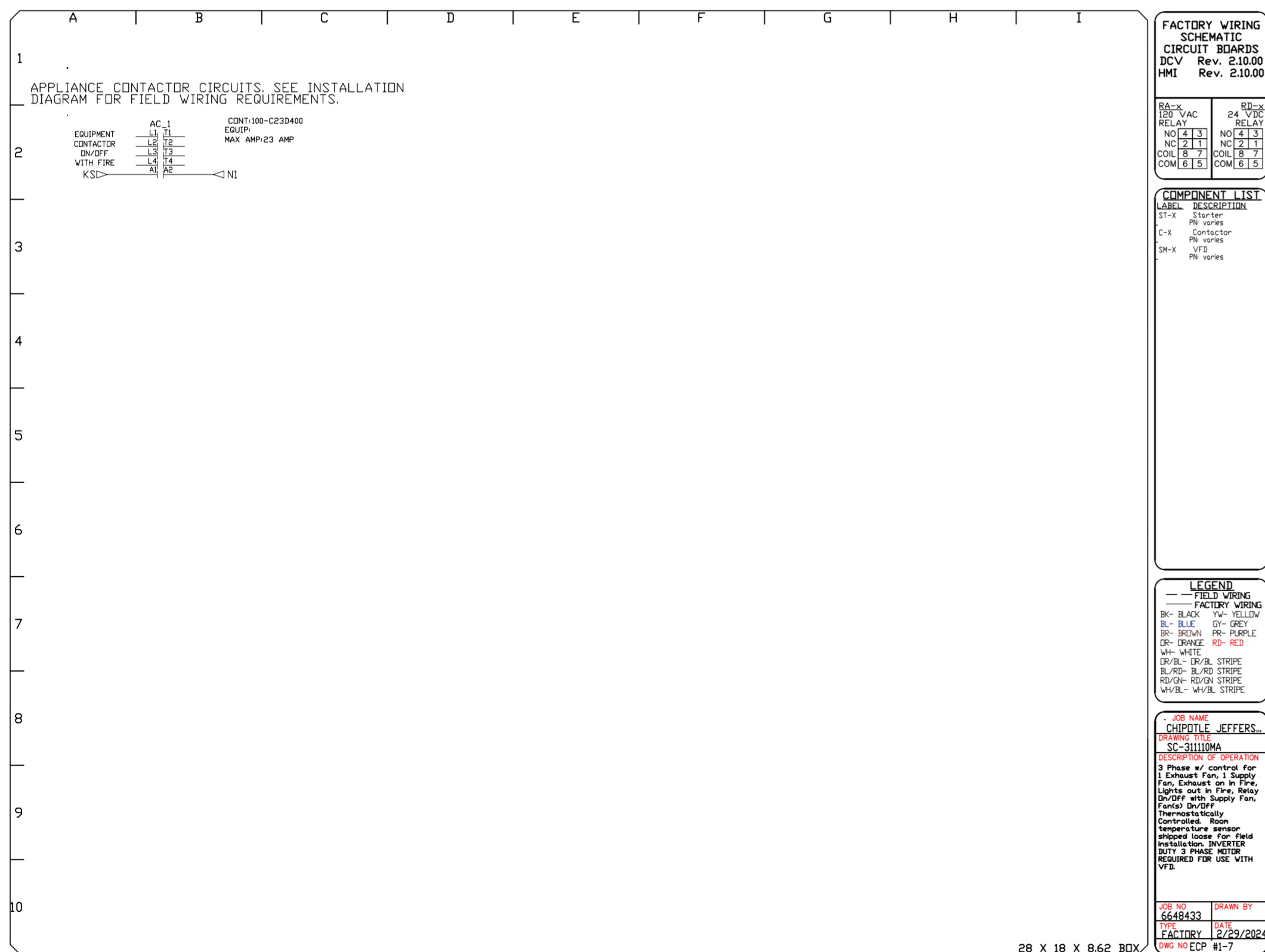
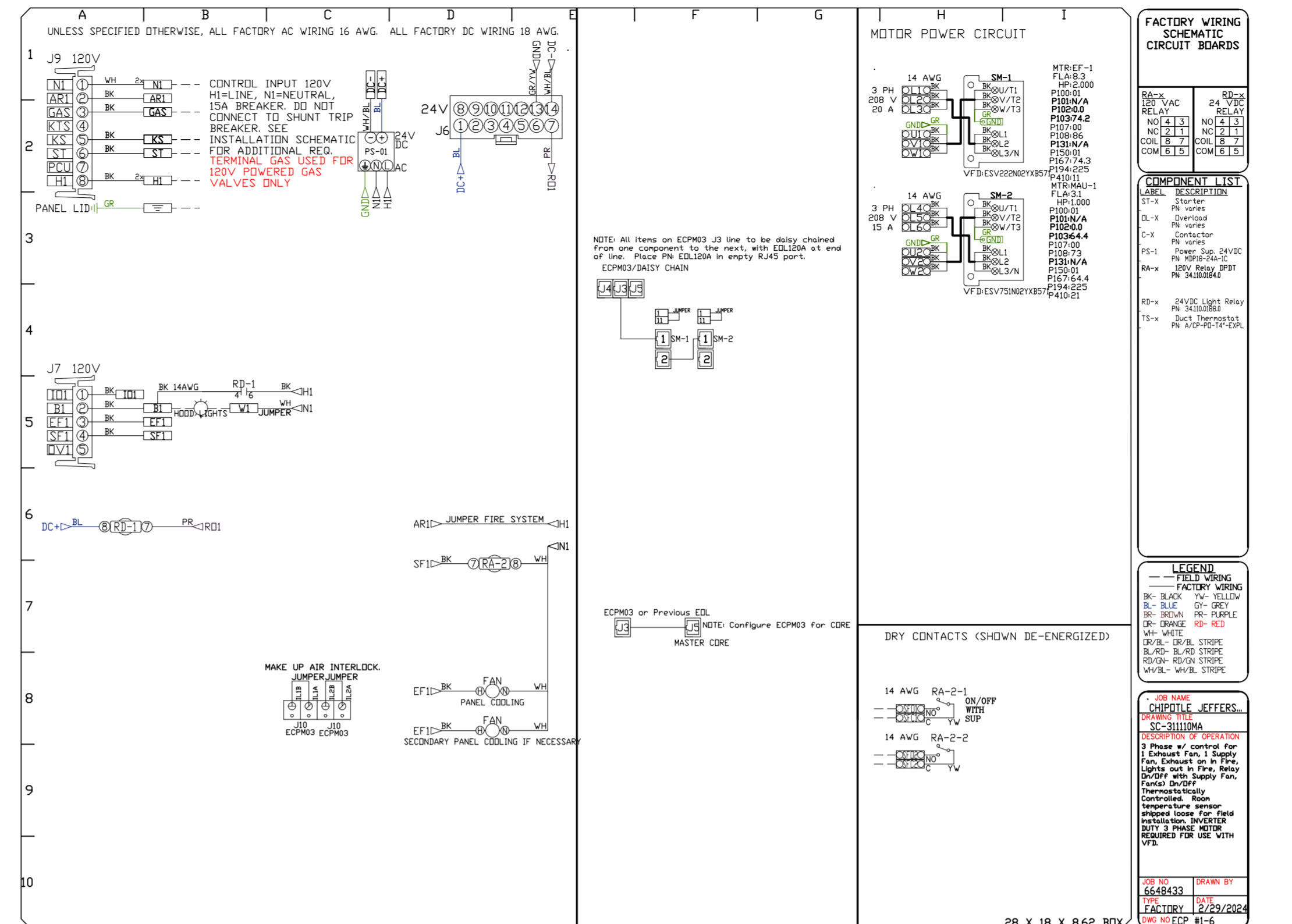
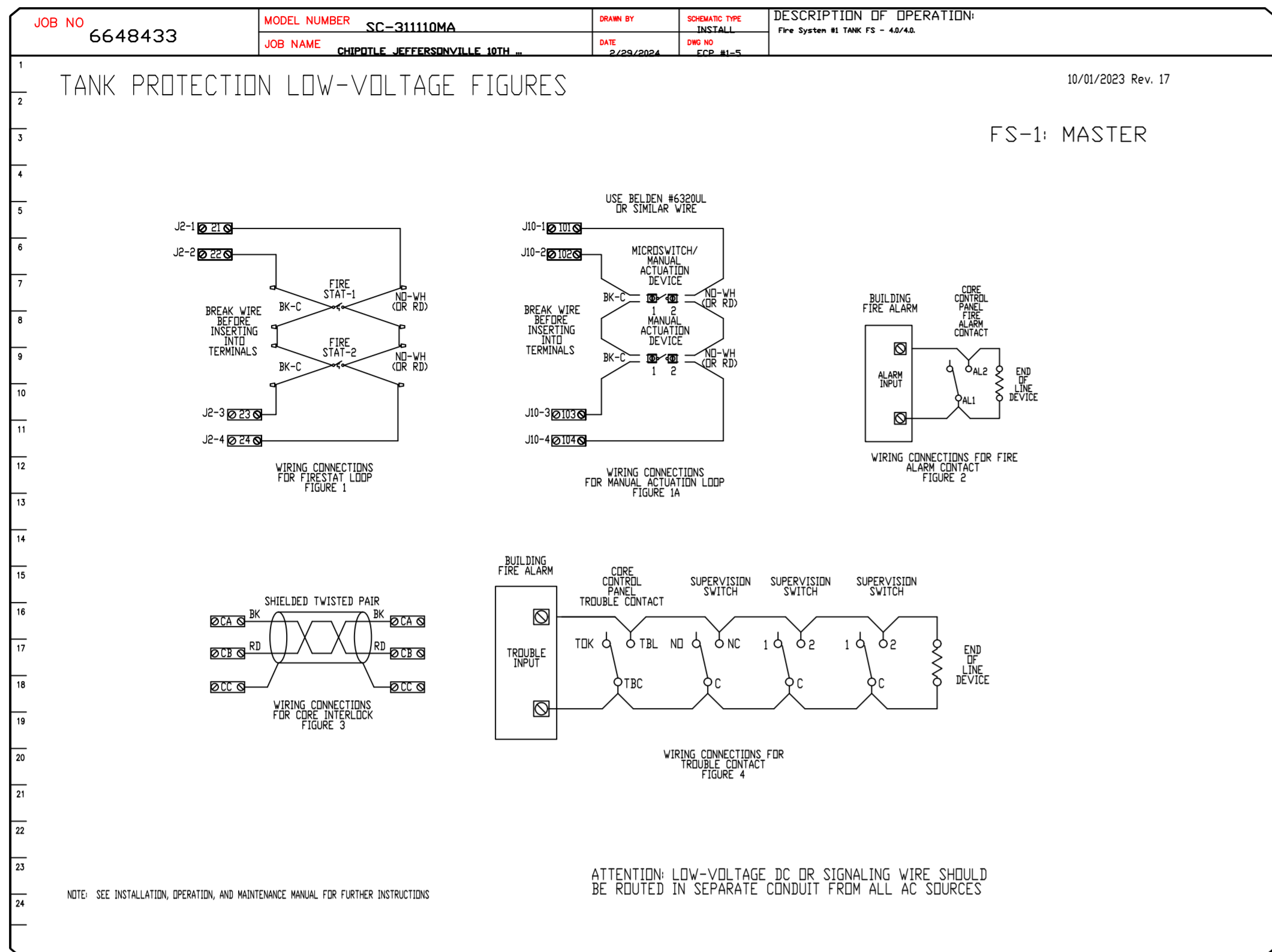

REVISIONS	
DESCRIPTION	DATE

Highwoods Group

www.captive.com

4641 Paragon Park Rd., Raleigh, NC, 27616 PHONE: (919) 875 - 0420 FAX: 9198760377 EMAIL: reg40@captive.com

CHIPOTLE JEFFERSONVILLE 10TH ST #5129
JEFFERSONVILLE, IN, 47130

DATE: 2/29/2024

DWG.#:
6648433

DRAWN BY:
JMB-40

SCALE:
3/4" = 1'-0"

MASTER DRAWING

SHEET NO.
10