

- ### KEYED NOTES
- IF NOT EXISTING, EC TO FURNISH DUCT MOUNTED SMOKE DETECTOR AND PROVIDE COMPATIBLE REMOTE ANNUNCIATOR/TEST SWITCH. MC TO INSTALL SMOKE DETECTOR IN RETURN DUCT, PRIOR TO ANY OUTDOOR AIR CONNECTIONS. MC TO PROVIDE INTERLOCK WIRING BETWEEN SMOKE DETECTOR AND UNIT TO SHUT DOWN UNIT UPON DETECTION OF SMOKE. EC SHALL PROVIDE WIRING FOR FINAL CONNECTION TO CENTRAL FIRE ALARM SYSTEM, IF APPLICABLE, AND WIRING TO REMOTE ANNUNCIATOR/TEST SWITCH.
 - EXISTING HOOD AND EXHAUST DUCTWORK TO REMAIN. MC TO SERVICE HOOD TO ASSURE THEY ARE OPERATING PROPERLY. FIELD VERIFY HOOD SYSTEM IS CAPABLE OF CONTAINING SMOKE AS REQUIRED TO MAINTAIN UL 710 RATING.
 - EXISTING HOOD AND GREASE DUCTWORK TO BE SERVICED AND CLEANED BY PROFESSIONAL HOOD CLEANERS AND ANY DAMAGED FIRE WRAP TO BE REPLACED LIKE NEW WITH 2 LAYERS OF 3M 615+ FIRE WRAP OR EQUIVALENT.
 - PROVIDE 1/2"x1/2" WIRE MESH COVER ON BOTTOM OF RETURN DUCT (RTU-2 ONLY)
 - PROVIDE UL 555 LISTED, RUSKIN MODEL DIBD2, OR EQUIVALENT, DYNAMIC 1.5 HR TYPE B FIRE DAMPER AND INSTALL IN FIRE RATED WALL IN LOCATION INDICATED. PROVIDE ACCESS DOORS ON BOTH SIDES OF FIRE DAMPER. PROVIDE RUSKIN, OR EQUIVALENT, MODEL FDR1 DAMPER FOR ROUND DUCTWORK PENETRATING FIRE RATED WALL. PROVIDE UL555S RUSKIN MODEL SD60, OR EQUIVALENT, SMOKE DAMPER AND INSTALL IN SMOKE WALL. EC TO PROVIDE SMOKE DETECTOR AND WIRE SMOKE DETECTOR TO SMOKE DAMPER ACTUATOR.
 - ALL NEW SPIRAL DUCTWORK TO BE PAINT GRIP GALVANIZED TO ALLOW FOR FIELD PAINTING.
 - EXISTING AIR CURTAIN ABOVE DOOR TO REMAIN. MC TO SERVICE AIR DOOR TO ASSURE IT IS OPERATING PROPERLY AND PROTECT DURING CONSTRUCTION.
 - EXISTING AIR CURTAIN TO BE RELOCATED ABOVE NEW DOOR. MC TO SERVICE AIR DOOR TO ASSURE IT IS OPERATING PROPERLY AND PROTECT DURING CONSTRUCTION.
 - PROVIDE MOTOR OPERATED DAMPER POWERED BY A 24V HONEYWELL, OR EQUIVALENT, ACTUATOR INTERLOCKED WITH THE OPERATION OF THE EQUIPMENT THAT IT SERVES, AND BALANCED TO CFM INDICATED. MAINTAIN MINIMUM 10' SEPARATION BETWEEN OUTDOOR AIR INTAKE AND EXHAUST AIR. MOTOR OPERATED DAMPERS SHALL BE PROVIDED AND WIRED BY THE MECHANICAL CONTRACTOR UNLESS OTHERWISE NOTED. PROVIDE ALL NECESSARY TRANSFORMERS, CONTACTORS, CONTROLS AND WIRING FOR INTERLOCKING HVAC EQUIPMENT TO MOTOR OPERATED DAMPERS. PROVIDE ALL DUCT TRANSITIONS AS REQUIRED OR INDICATED.
 - RELOCATE THERMOSTAT FROM EXISTING LOCATION TO NEW LOCATION INDICATED. EXTEND AND RECONNECT CONTROL WIRING AS REQUIRED.
 - REPLACE EXISTING AIR DEVICE WITH NEW LIKE AIR DEVICE AND REBALANCE TO MEASURED CFM.
 - EXISTING THERMOSTAT TO REMAIN, PROTECT DURING CONSTRUCTION.
 - PROVIDE NEW INLINE AIR FAN. SUPPORT FAN FROM STRUCTURE WITH BEAM CLAMPS, THREADED RODS AND SPRING VIBRATION ISOLATORS, AS REQUIRED.
 - PROVIDE NEW INLINE DUCT HEATER IN LOCATION INDICATED. HEATER TO BE CONTROLLED BY THERMOSTAT ON BOILER ROOM.
 - PROVIDE THERMOSTAT AND MOUNT ON WALL 4 FEET A.F.F.
 - INTERNALLY LINE FIRST 10 FEET OF OUTSIDE AIR DUCTWORK WITH JOHN'S MANVILLE, OR EQUIVALENT, 1 INCH THICK SPIRACOUS FIBERGLASS DUCT LINER. DUCT SIZES SHOWN ARE CLEAR INSIDE DIMENSIONS.
 - ROUTE B-VENT BOILER FLUE THROUGH SIDEWALL, IN ACCORDANCE WITH THE BOILER MANUFACTURER'S REQUIREMENTS. SEAL PENETRATION, THROUGH SMOKE WALL, WITH HILTI FS-ONE MAX FIRESTOP SEALANT.
 - COORDINATE ALL BOILER ROOM REQUIREMENTS WITH BREWMASTER.
 - CONNECT NEW DUCTWORK TO EXISTING DUCTWORK AS INDICATED.
 - REMOVE EXISTING DUCTWORK AS INDICATED AND SEAL ANY OPENINGS IN EXISTING DUCT MAINS AIR TIGHT IN ACCORDANCE WITH SMACNA GUIDELINES.
 - RELOCATE EXISTING AIR DEVICE TO LOCATION INDICATED AND SEAL ANY OPENINGS IN EXISTING DUCT MAINS AIR TIGHT IN ACCORDANCE WITH SMACNA GUIDELINES.
 - PROVIDE WALL LOUVER, AND MOUNT HIGH ON WALL, COMPLETE WITH BIRDSCREEN. PROVIDE DUCTWORK PLENUM BOX BEHIND LOUVER AND SEAL WATER TIGHT.
 - PROVIDE CO SENSOR AND REMOTE ANNUNCIATOR. CO SENSOR SHALL BE MOUNTED IN BOILER ROOM AT 5'-0" A.F.F. THE ANNUNCIATOR SHALL BE MOUNTED IN A VISIBLE LOCATION ON THE EXTERIOR OF THE BOILER ROOM.
 - EXISTING DUCT ELECTRIC DUCT HEATERS AND ASSOCIATED THERMOSTATS TO REMAIN. MECHANICAL CONTRACTOR TO SERVICE HEATER TO ASSURE ITS OPERATING PROPERLY AND PROTECT DURING CONSTRUCTION.
 - EXISTING JANITOR GRILLE AND ASSOCIATED DUCTWORK TO REMAIN FOR MALL'S JANITOR'S CLOSET.
 - EXISTING BY-PASS ABOVE CEILING TO REMAIN.
 - DISHWASHER PANTELEG EXHAUST CONNECTION, REFER TO MANUFACTURERS INSTALLATION INSTRUCTIONS FOR MORE INFORMATION. DUCT SHALL BE MADE OF ALUMINUM. JOINTS, SEAMS, AND PENETRATIONS SHALL BE SEALED TO PROVIDE A SMOOTH INNER SURFACE AND SHALL BE WATER TIGHT. HORIZONTAL DUCTWORK SERVING SHALL BE SLOPED DOWN IN THE DIRECTION OF THE DISHWASHER. SLOPE DUCT AT 1/8"/FT.
 - PROVIDE RUSKIN, OR EQUIVALENT MODEL ELF375DX EXHAUST LOUVER AND BIRDSCREEN AND MOUNT HIGH ON WALL.

PRELIMINARY
 NOT FOR CONSTRUCTION

This document is partially complete. The information contained is not necessarily coordinated or correct. This drawing is for review purposes only.

2022 MARQUE ENGINEERING LLC ©
 THIS PLAN IS PROTECTED UNDER FEDERAL COPYRIGHT LAWS. THE ORIGINAL PURCHASER IS AUTHORIZED TO CONSTRUCT WITH THIS PLAN FOR ONE TIME. REUSE OR CHANGE OF THIS PLAN IS PROHIBITED. ALL IDEAS, DESIGN ARRANGEMENTS, AND PLANS INDICATED HEREIN ARE OWNED BY AND THE PROPERTY OF MARQUE ENGINEERING LLC. NOTHING ON THESE PLANS SHALL BE REUSED WITHOUT THE WRITTEN PERMISSION OF MARQUE ENGINEERING LLC. IF PLANS ARE NOT PRESENTED FOR PERMIT REVIEW WITHIN 30 DAYS OF ENGINEER SIGNATURE THIS SHEET IS VOID AND WILL NEED TO BE UPDATED BY THE ENGINEER OF RECORD.

16 YEARS OF SERVICE
SOUTHERN OUTPOST
 Newport on the Levee
 Newport, Kentucky 41071

1 MECHANICAL PLAN
 M1.0 3/16" = 1'-0"

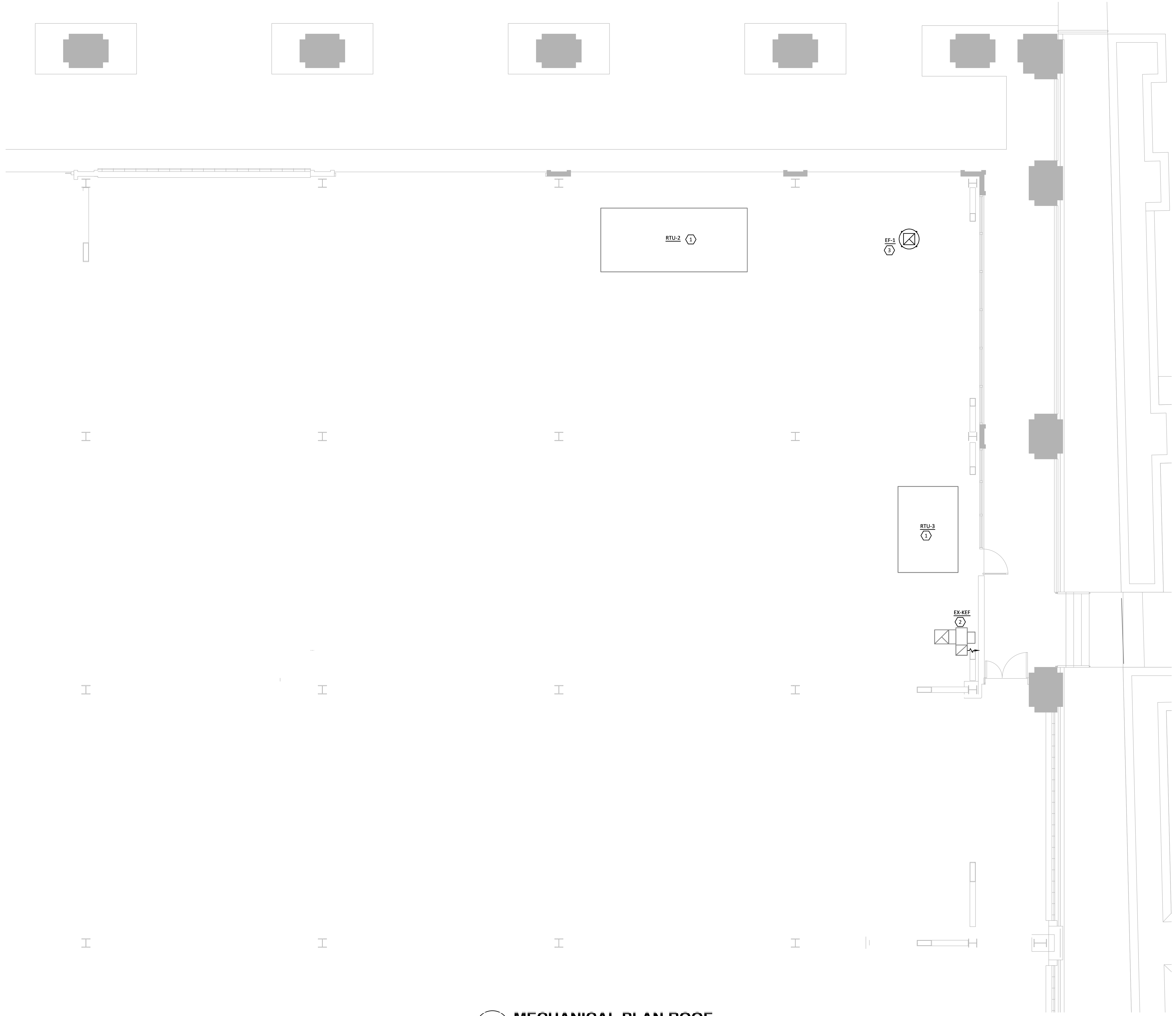

- KEYED NOTES**
- EXISTING ROOFTOP UNIT TO REMAIN. MECHANICAL CONTRACTOR TO FIELD VERIFY EXACT LOCATION PRIOR TO BID AND SERVICE UNIT TO ASSURE IT IS OPERATING PROPERLY. REPLACE ALL FILTERS PRIOR TO LEAVING THE JOB SITE. BALANCE SUPPLY AND OA TO CFM INDICATED
 - EXISTING TYPE I EXHAUST FAN AND ALL ASSOCIATED DUCTWORK TO REMAIN. MC TO SERVICE FAN TO ASSURE IT IS OPERATING PROPERLY AND PROTECT DURING CONSTRUCTION. FIELD VERIFY EXACT LOCATION PRIOR TO BID.
 - EXISTING ROOF MOUNTED EXHAUST FAN AND ASSOCIATED CURB TO BE REMOVED. PROVIDE EXHAUST FAN AND INSTALL ON 12" HIGH INSULATED ROOF CURB IN EXISTING PENETRATION LOCATION. MAINTAIN MINIMUM 10' CLEARANCE FROM ANY OUTDOOR AIR INTAKES. FIELD VERIFY EXACT LOCATION PRIOR TO BID.

MARQUE ENGINEERING
 2230 PARK AVE., STE. 100, CINCINNATI, OH 45206
 513.457.7131 - WWW.MARQUEENG.COM
 KY COA #4790

PRELIMINARY
 NOT FOR CONSTRUCTION

This document is partially complete. The information contained is not necessarily coordinated or correct. This drawing is for review purposes only.

2022 MARQUE ENGINEERING LLC ©

THIS PLAN IS PROTECTED UNDER FEDERAL COPYRIGHT LAWS. THE ORIGINAL PURCHASER IS AUTHORIZED TO CONSTRUCT WITH THIS PLAN FOR ONLY ONE TIME. REUSE OR CHANGE OF THIS PLAN IS PROHIBITED. ALL IDEAS, DESIGN ARRANGEMENTS, AND PLANS INDICATED HEREIN ARE OWNED BY AND THE PROPERTY OF MARQUE ENGINEERING LLC. NOTHING ON THESE PLANS SHALL BE REUSED WITHOUT THE WRITTEN PERMISSION OF MARQUE ENGINEERING LLC. IF PLANS ARE NOT PRESENTED FOR PERMIT REVIEW WITHIN 30 DAYS OF ENGINEER SIGNATURE THIS SHEET IS VOID AND WILL NEED TO BE UPDATED BY THE ENGINEER OF RECORD.



SOUTHERN OUTPOST
 Newport, Kentucky 41071

Sheet M1.1
 MECHANICAL PLAN ROOF
 26 August 2022 - 90% Review Set

EXISTING ROOFTOP UNIT SCHEDULE																			
TAG	MANUFACTURER	MODEL	NOMINAL TONNAGE	SUPPLY CFM	OA CFM	ESP IN IN. W.C.	TOT BTUH	SENS BTUH	(S)EER	STAGE	HTG IN BTUH	HTG OUT BTUH	ELECTRICAL				WEIGHT	REMARKS	
													BHP	VOLTAGE	PHASE	FLA			MCA
RTU-2	TRANE	YCD420A4	30.0	12000	4420	-	-	-	-	-	-	-	-	480	3	-	-	EXIST.	A,B,C
RTU-3	TRANE	YCD211C4H1	15.0	6000	6000	-	-	-	-	-	-	-	-	480	3	-	-	EXIST.	A,B,C

REMARKS:
 A. ALL HVAC EQUIPMENT TO BE FIELD LABELED TO IDENTIFY WHICH AREAS OF THE BUILDING THEY SERVE.
 B. MERV 13 PLEATED FILTER.
 C. EXISTING ROOFTOP UNIT. MECHANICAL CONTRACTOR TO SERVICE ROOFTOP UNIT TO ASSURE IT IS OPERATING PROPERLY AND REPLACE ALL FILTERS.

EXHAUST FAN SCHEDULE												
TAG	MANUFACTURER	MODEL	CFM	ESP	RPM	B.H.P.	VOLTAGE	PHASE	WEIGHT LBS	SONES	REMARKS	
												EF-1
EF-2	GREENHECK	BSQ-90	600	1.0	1827	0.35	120	1	88	14.4	A,B,C,D	
SF-1	GREENHECK	BSQ-80	270	1.0	1703	0.21	120	1	80	11.6	D,E,F	

REMARKS:
 A. WEATHERPROOF DISCONNECT.
 B. 12" HIGH INSULATED ROOF CURB
 C. BIRD SCREEN
 D. BACKDRAFT DAMPER
 E. DISCONNECT SWITCH
 F. HANGING VIBRATION ISOLATORS

ELECTRIC DUCT HEATER SCHEDULE									
TAG	MANUFACTURER	MODEL	CFM	KW	STAGES	ELECTRICAL			REMARKS
						VOLTAGE	PHASE	FLA	
EH-1	-	-	2000	20	-	480	3	-	1
EH-2	-	-	1600	15	-	480	3	-	1
EH-3	WARREN	CBK	270	5.0	1	480	3	6.01	2

REMARKS:
 1. EXISTING OPEN COIL DUCT HEATER WITH FLANGED FRAME AND AIRFLOW PROVING SWITCH. MECHANICAL CONTRACTOR TO SERVICE HEATER TO ASSURE IT IS OPERATING PROPERLY.
 2. OPEN COIL DUCT HEATER WITH FLANGED FRAME, AIRFLOW PROVING SWITCH AND HIGH TEMPERATURE ALARM.

AIR DEVICE SCHEDULE									
TAG	MANUFACTURER	MODEL	FUNCTION	FACE SIZE	DUCT SIZE	BORDER TYPE	MATERIAL	FINISH	REMARKS
CD-2	PRICE	PDDR	SUPPLY	24x24	-	LAY-IN	STEEL	WHITE	A,B
SR-1	PRICE	SDGE	SUPPLY	19x14	18x12	DUCT	STEEL	CLEAR ANOD.	D
ER-1	PRICE	80	EXHAUST	12x12	-	LAY-IN	ALUMINUM	WHITE	B
ER-2	PRICE	80	EXHAUST	24x24	-	LAY-IN	ALUMINUM	WHITE	B
RG-1	PRICE	80	RETURN	24x24	-	LAY-IN	ALUMINUM	WHITE	B

REMARKS:
 A. PROVIDE VOLUME DAMPERS IN TAKEOFFS WHERE ACCESSIBLE. WHERE DAMPERS ARE NOT ACCESSIBLE, PROVIDE OPPOSED BLADE DAMPER AT DIFFUSER.
 B. COORDINATE FRAME TYPE WITH ARCHITECTURAL REFLECTED CEILING PLAN.
 C. PLAQUE DIFFUSER
 D. SCOOP DAMPER.

LOUVER SCHEDULE									
TAG	MANUFACTURER	MODEL	FUNCTION	FACE SIZE	BORDER TYPE	MATERIAL	FINISH	REMARKS	
									L-1
L-2	RUSKIN	ELF-375DX	EXHAUST AIR	20x20	FLANGE	ALUMINUM	SEE ARCH.	A,B,C,D,E	

REMARKS:
 A. DESIGNED TO PROTECT AGAINST WIND DRIVEN RAIN.
 B. ARCHITECT TO CHOOSE COLOR.
 C. CONTRACTOR TO PROVIDE OPENING IN EXISTING WALL.
 D. PROVIDE WITH CLEAR ANODIZED FINISH.
 E. BIRD SCREEN.

HVAC DESIGN CONDITIONS	
COOLING: OUTDOOR = 91°FDB/74°FWB INDOOR = 72°FDB/50°RH	HEATING: OUTDOOR = 1°FDB INDOOR = 70°FDB

GENERAL NOTES
A. THE DRAWINGS ARE DIAGRAMMATIC IN NATURE. EXACT LOCATIONS OF DEVICES AND ROUTING OF DUCTWORK SHALL BE DETERMINED BY CONTRACTOR AFTER COORDINATION WITH ALL OTHER TRADES AND FIELD DETERMINATION OF FINAL CONSTRUCTION DETAILS. MINOR ADJUSTMENTS TO DUCT ROUTING AND CONFIGURATION TO AVOID CONFLICT WITH BUILDING STRUCTURE OR OTHER TRADES SHALL BE INCLUDED IN CONTRACTOR'S PRICE. CONTRACTOR SHALL OBTAIN ENGINEERS APPROVAL IN WRITING FOR ANY MODIFICATIONS TO SYSTEM DESIGN PRIOR TO INSTALLATION.
B. ALL EXPOSED MATERIALS AND EQUIPMENT SHALL BE INSTALLED AND SUPPORTED IN A FIRST-CLASS AND WORKMANLIKE FASHION. DUCTWORK SHALL RUN PARALLEL AND/OR PERPENDICULAR TO MAIN BUILDING STRUCTURE. ANY WORK THAT IS NOT DONE IN A FIRST-CLASS OR WORKMANLIKE FASHION, IN THE ARCHITECTS OPINION, SHALL BE REDONE AT THE CONTRACTORS EXPENSE.
C. ALL DUCT JOINTS, SEAMS AND CONNECTIONS SHALL BE SECURELY FASTENED AND SEALED. DUCTS SHALL BE SUPPORTED WITH APPROVED HANGERS AT INTERVALS NOT EXCEEDING TEN FEET. DUCT COVERINGS AND LININGS SHALL HAVE A FLAME-SPREAD INDEX NOT MORE THAN 25 AND A SMOKE DEVELOPED INDEX NOT MORE THAN 50.
D. PROVIDE VOLUME DAMPERS AT ALL ROUND BRANCH DUCT TAKE-OFFS THAT ARE ACCESSIBLE. PROVIDE TURNING VANES AT ALL 90 DEGREE SQUARE ELBOWS IN SUPPLY AIR DUCTS. PROVIDE 45 DEGREE HEEL AT ALL RECTANGULAR SUPPLY AND RETURN BRANCH DUCT TAKE-OFFS.
E. OUTDOOR AIR INTAKES SHALL BE 10'-0" MINIMUM AWAY FROM ANY EXHAUST AND PLUMBING VENT OUTLET.
F. WIRE UP ALL LOW VOLTAGE (24V) THERMOSTATS.
G. CONTRACTOR SHALL COORDINATE THE LOCATION OF ALL PIPES, DUCTWORK, UNITS, ETC. WITH ALL OTHER TRADES AND SHIFT LOCATION OR OFFSET WHERE NECESSARY. PROVIDE TRANSITIONS IN DUCTWORK TO AVOID CONFLICT WITH EXISTING DUCTWORK AND OTHER STRUCTURES.
H. CONTRACTOR SHALL COORDINATE ALL AIR DEVICES WITH ELECTRICAL AND ARCHITECTURAL REFLECTED CEILING PLANS.
I. COORDINATE LOCATION OF ALL EXTERIOR LOUVER OR OUTLET WITH ARCHITECTURAL ELEVATION PLAN.
J. COORDINATE ROOF WORK WITH BUILDING OWNER'S ROOFING CONTRACTOR TO ASSURE THAT THE ROOF WARRANTY IS NOT VOIDED.
K. INSTALL DUCTWORK AS HIGH AS POSSIBLE.
L. EXHAUST AIR DUCTS SHALL BE EQUIPPED WITH BACKDRAFT DAMPERS.
M. ALL DUCT OPENINGS AND OTHER AIR DISTRIBUTION OPENINGS SHALL BE COVERED DURING CONSTRUCTION EXCEPT FOR TESTING AND INSPECTION.
N. PROVIDE BUILDING OWNER OR REPRESENTATIVE WITH DETAILED OPERATING AND MAINTENANCE INSTRUCTIONS AND WARRANTIES /WRITTEN GUARANTEE FOR EACH SYSTEM. O&M INSTRUCTIONS SHALL BE CONSISTENT WITH OSHA REQUIREMENTS IN CCR TITLE 8, SECTION 5142 AND OTHER RELATED REGULATIONS.
O. ALL DUCT ELBOWS SHALL BE LONG RADIUS OR MITERED.

HVAC LEGEND	
	DRAWING NOTE SYMBOL
	NEW RECTANGULAR DUCTWORK AND SIZE
	NEW ROUND DUCTWORK AND SIZE
	BALANCING/VOLUME DAMPER
	FLEX DUCT
	THERMOSTAT
	NEW SUPPLY AIR DIFFUSER AND CFM
	NEW RETURN GRILLE
	NEW EXHAUST GRILLE AND CFM
	EXISTING EXHAUST GRILLE TO BE REMOVED
	AIR FLOW DIRECTION
	FIRE DAMPER
	SMOKE DETECTOR
	SUPPLY DUCT UP THROUGH ROOF
	RETURN/EXHAUST DUCT UP THROUGH ROOF
	MOTOR OPERATED DAMPER
	CONNECT TO EXISTING

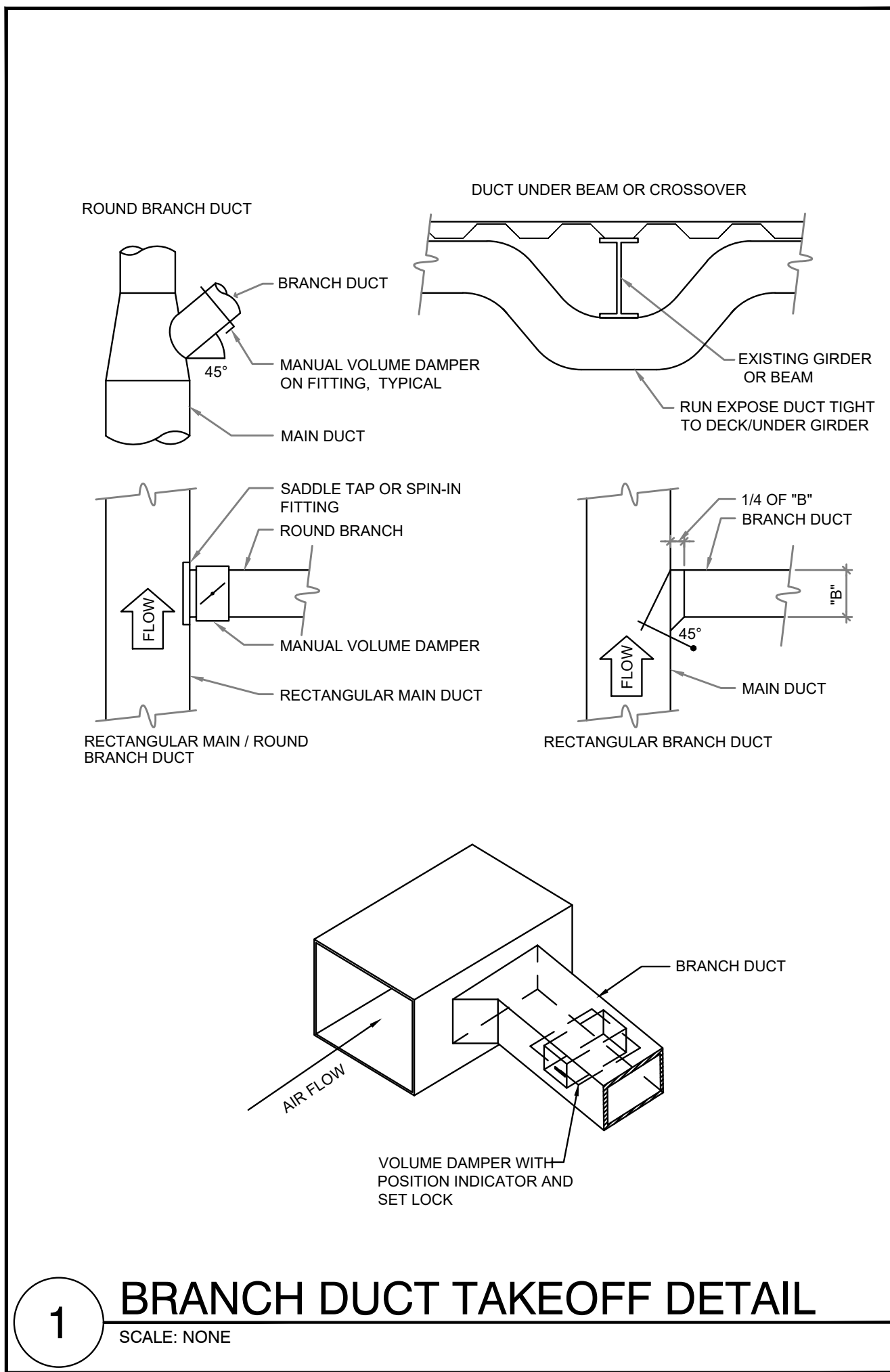

1 BRANCH DUCT TAKEOFF DETAIL
SCALE: NONE

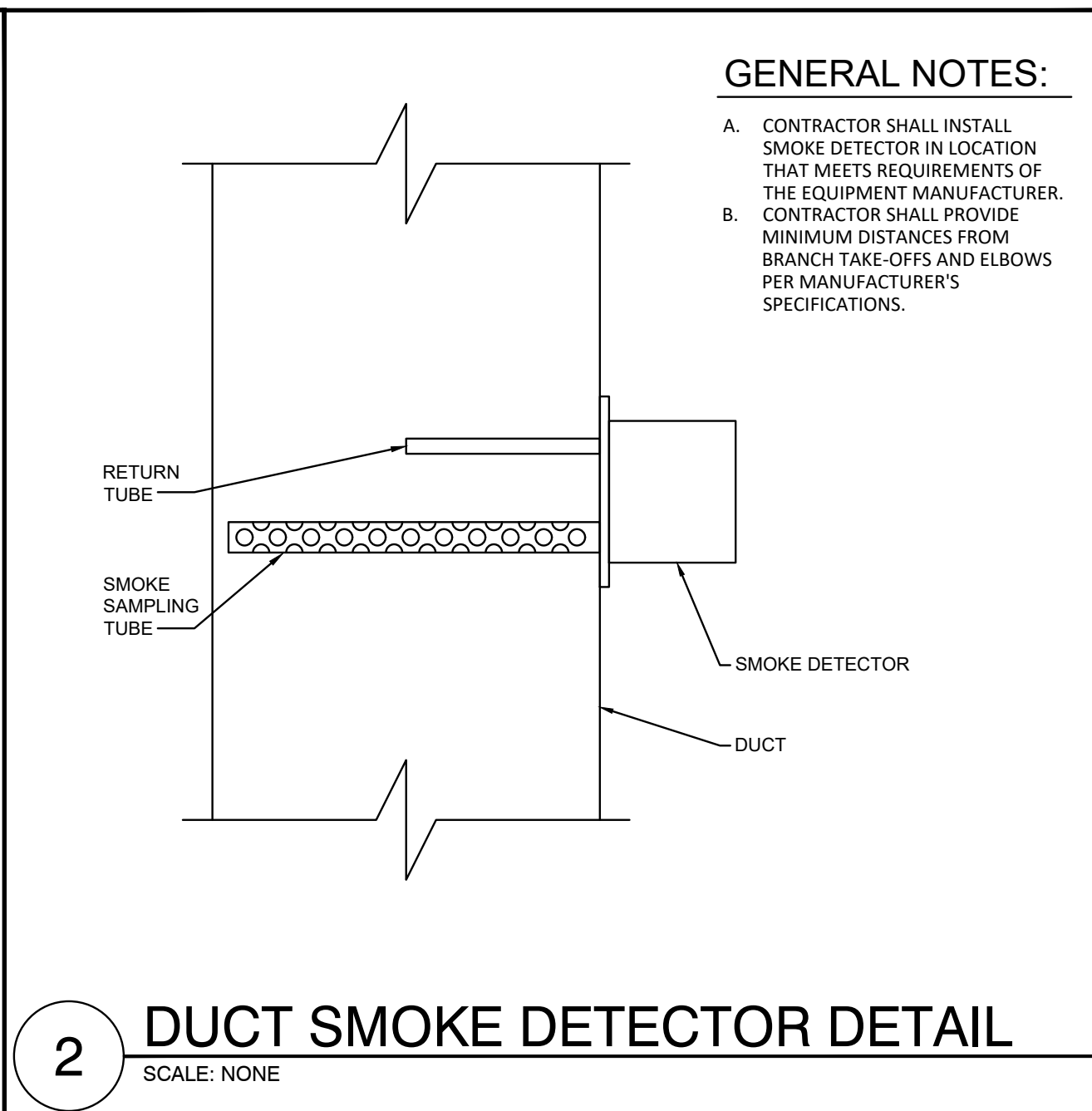

2 DUCT SMOKE DETECTOR DETAIL
SCALE: NONE

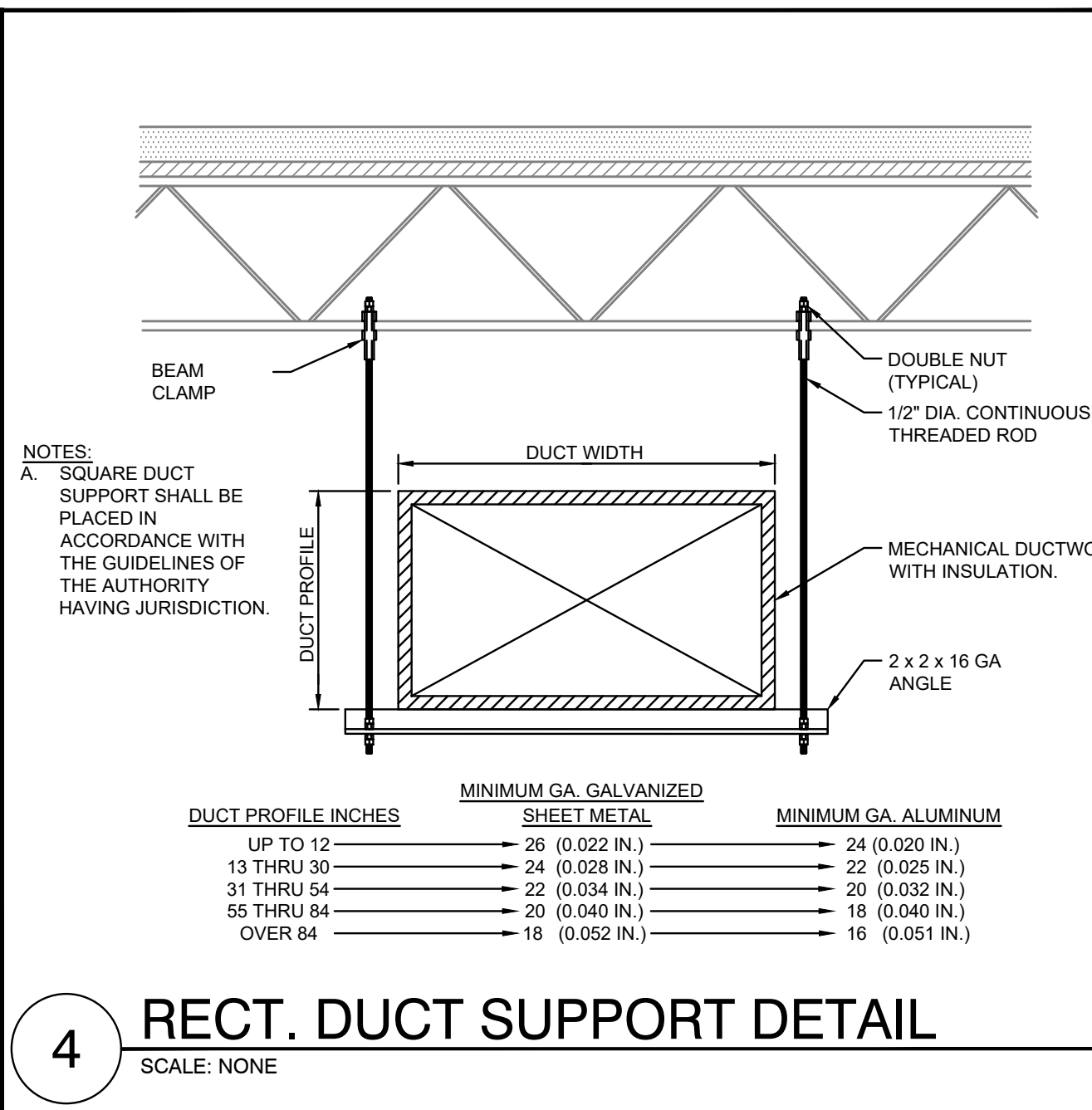

4 RECT. DUCT SUPPORT DETAIL
SCALE: NONE

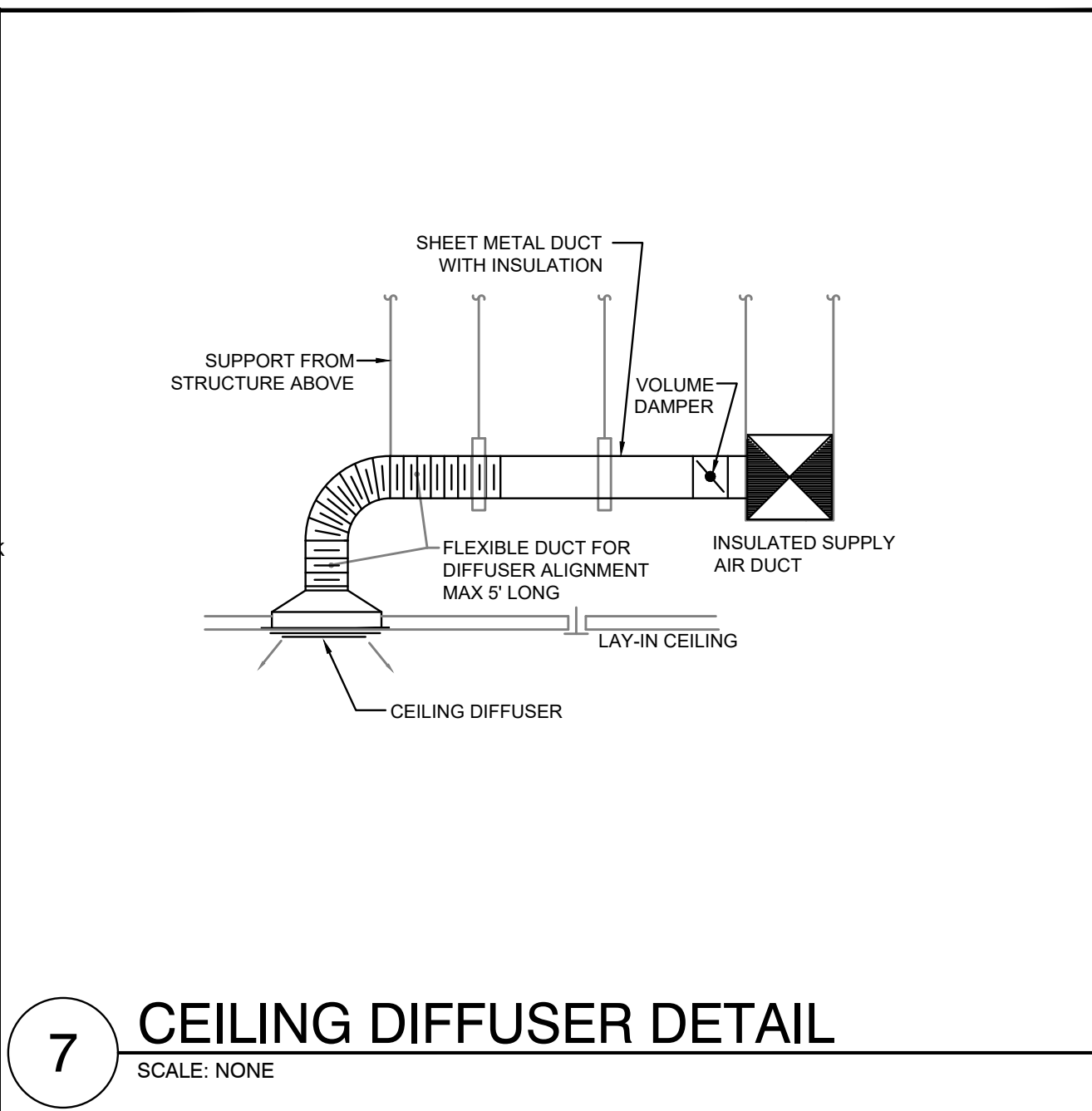

7 CEILING DIFFUSER DETAIL
SCALE: NONE

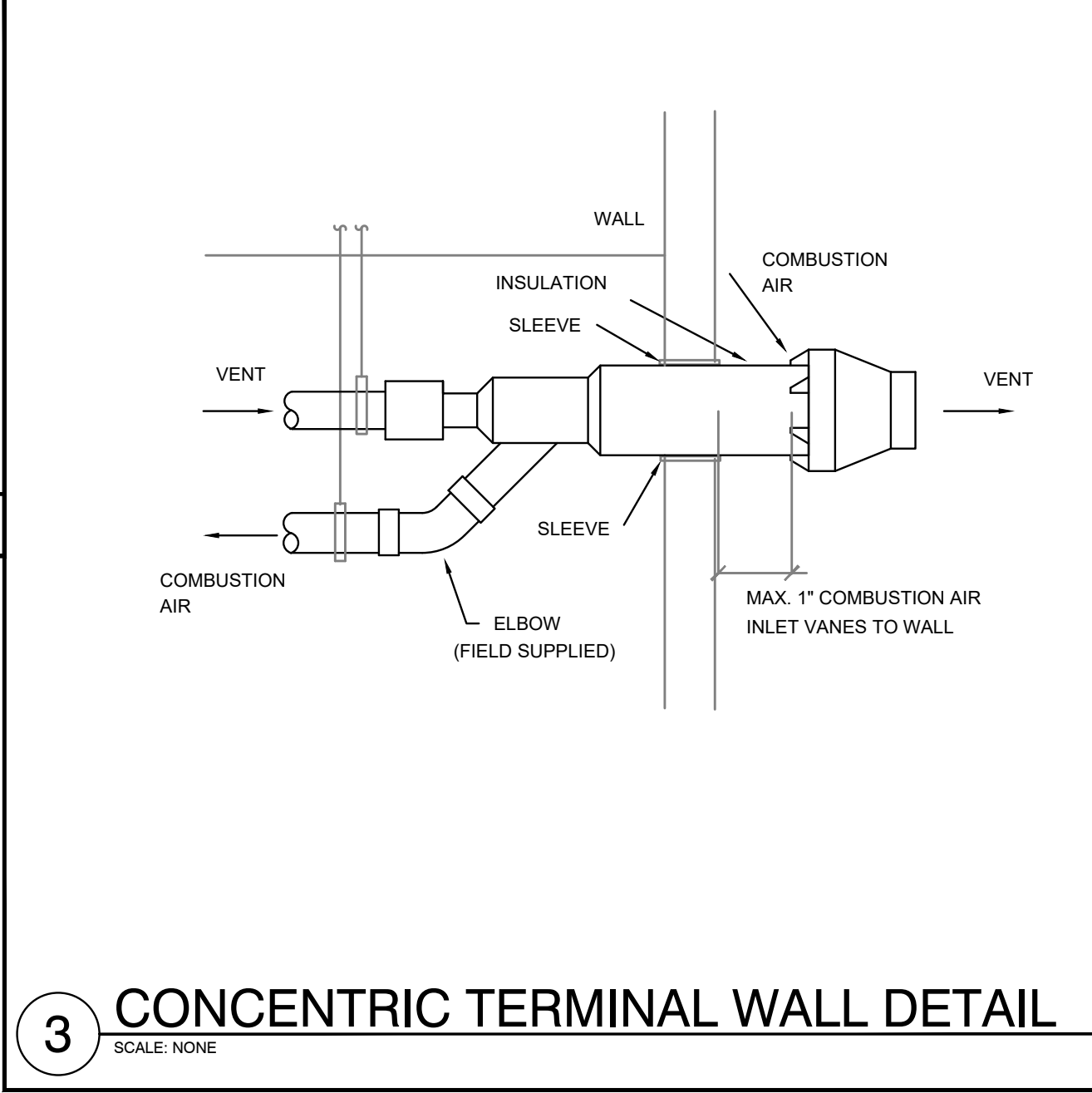

3 CONCENTRIC TERMINAL WALL DETAIL
SCALE: NONE

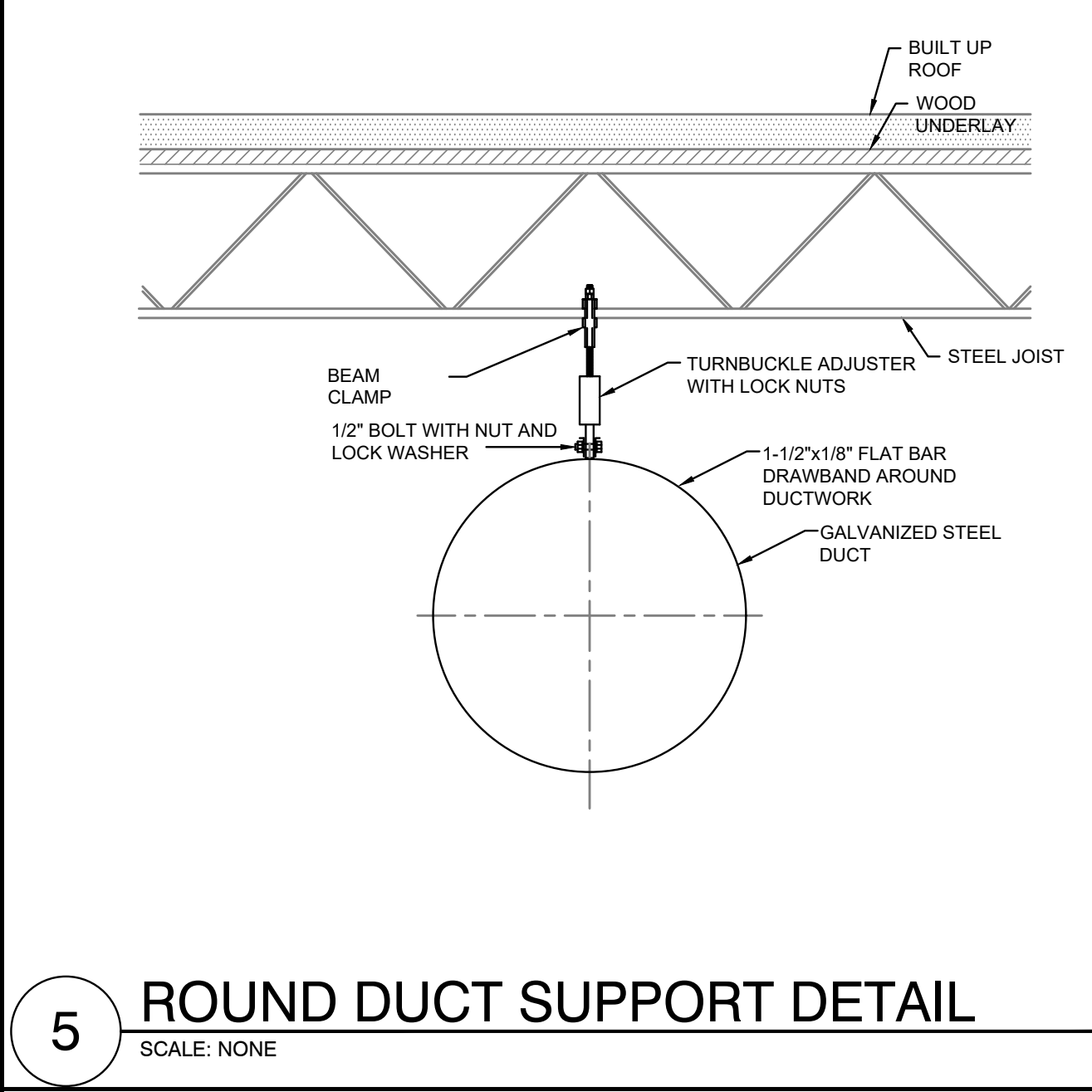

5 ROUND DUCT SUPPORT DETAIL
SCALE: NONE

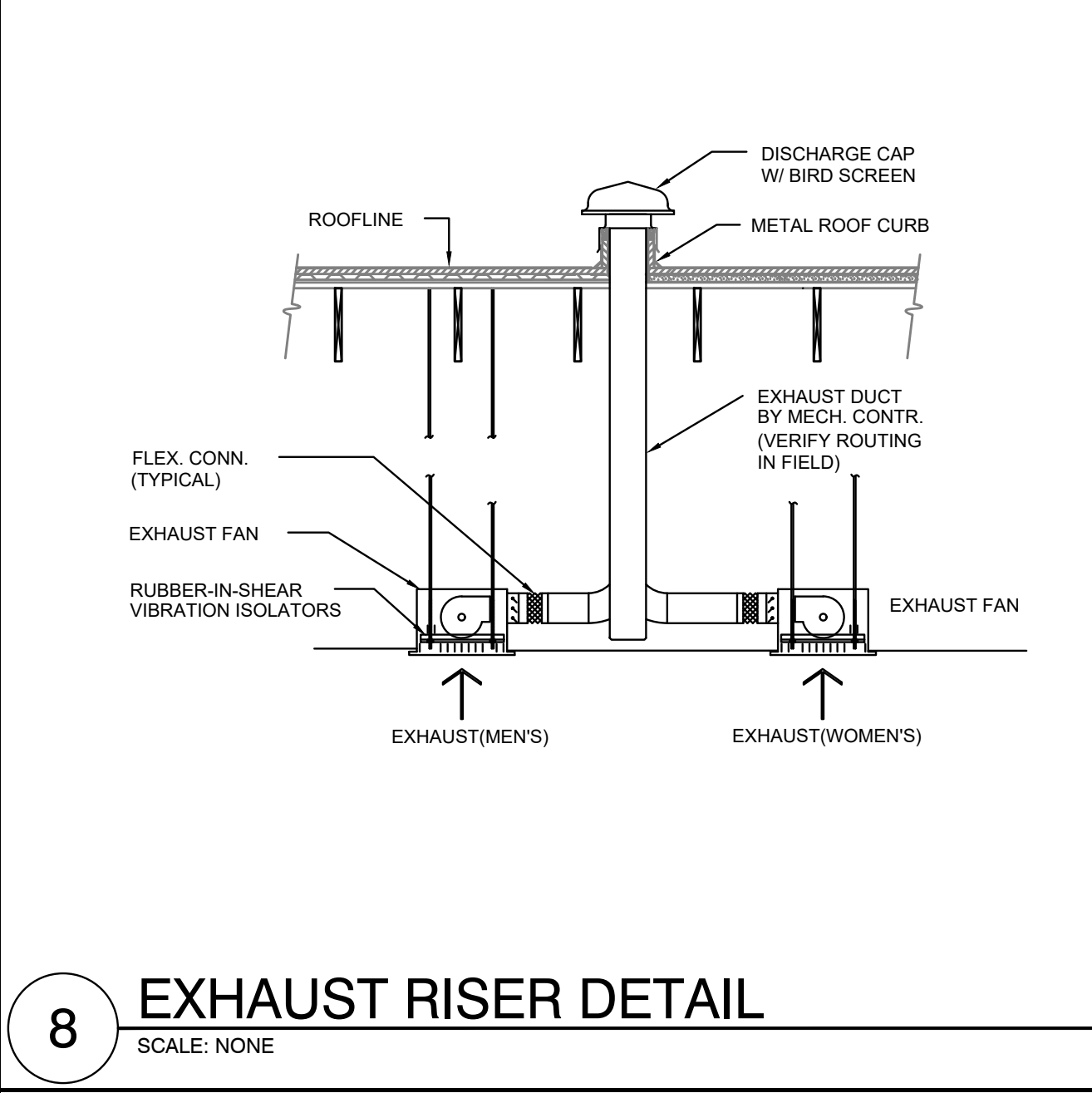

8 EXHAUST RISER DETAIL
SCALE: NONE

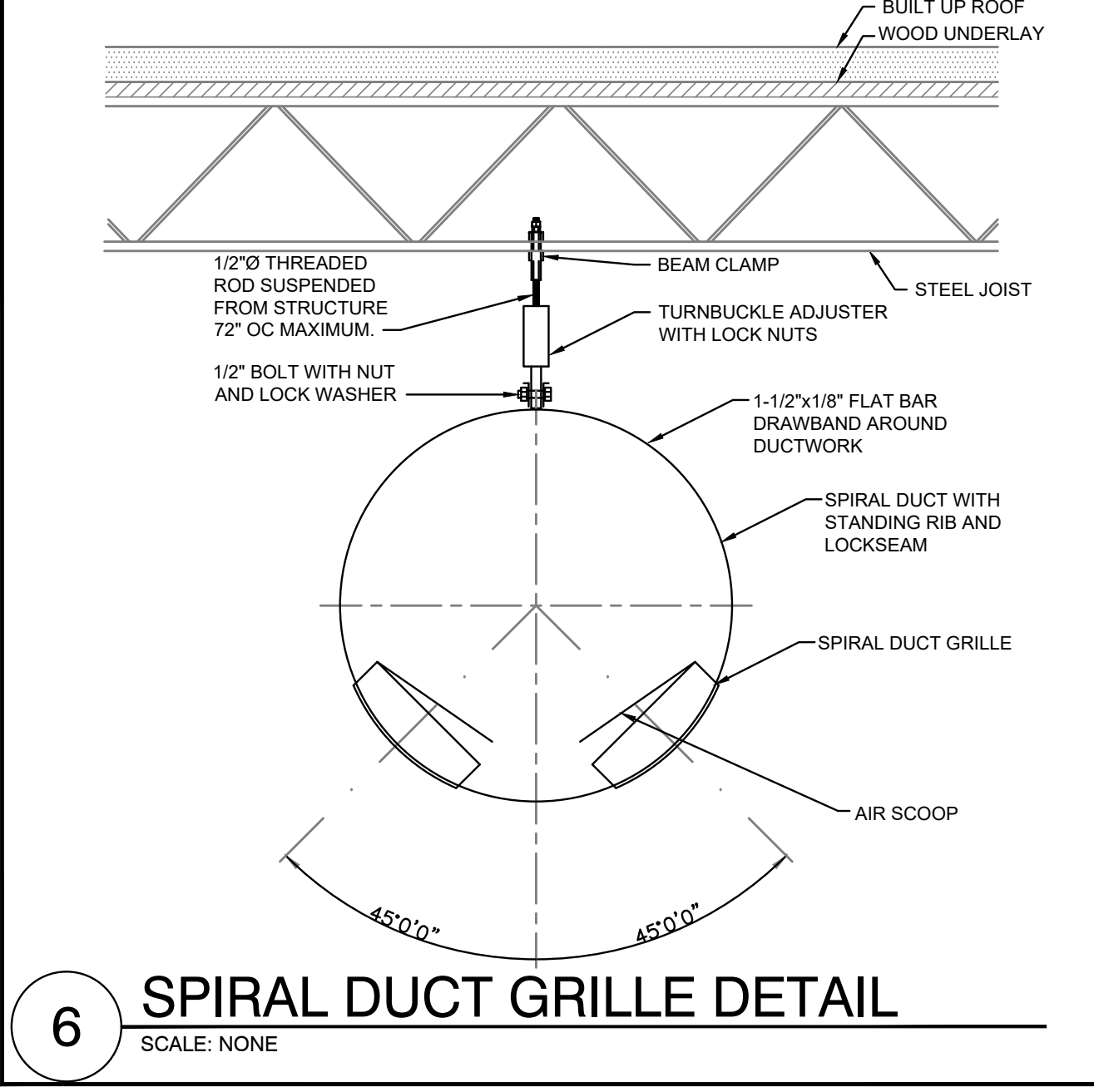

6 SPIRAL DUCT GRILLE DETAIL
SCALE: NONE

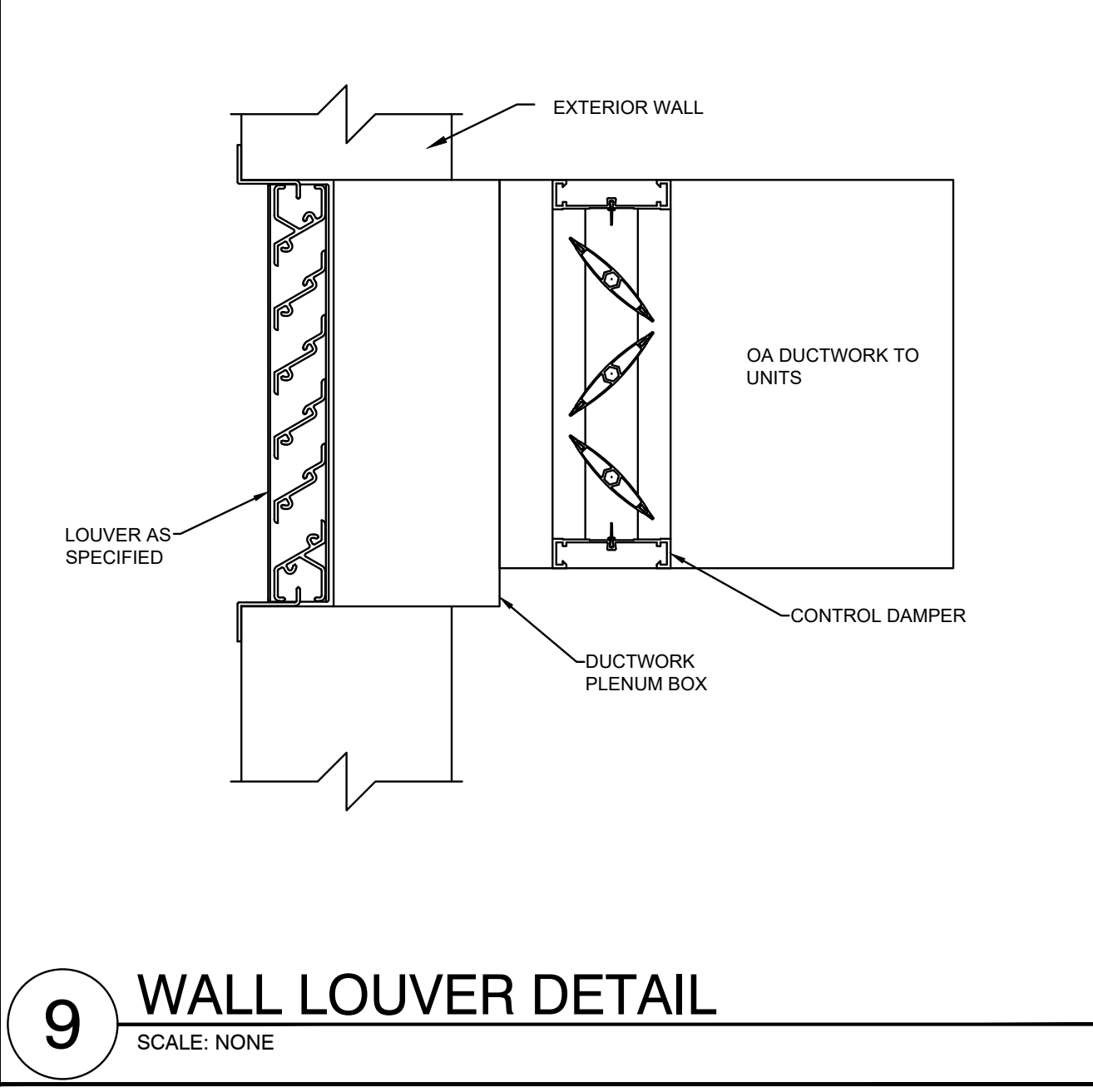

9 WALL LOUVER DETAIL
SCALE: NONE

DIVISION 23 MECHANICAL SPECIFICATIONS

23 05 01 COMMON REQUIREMENTS FOR HVAC

ALL MECHANICAL WORK AND TESTS SHALL BE DONE IN STRICT ACCORDANCE WITH THE LATEST STATE, COUNTY, AND LOCAL REGULATIONS, LAWS, AND ORDINANCES WHICH MAY BE APPLICABLE.

BEFORE SUBMITTING A BID, EXAMINE DOCUMENTS OF ALL OTHER TRADES, VISIT THE SITE AND GET ACQUAINTED WITH ALL CONDITIONS THAT MAY IN ANY WAY AFFECT THE EXECUTION OF THIS CONTRACT. TAKE MEASUREMENTS AND BE RESPONSIBLE FOR EXACT SIZE AND LOCATIONS OF ALL OPENINGS REQUIRED. VERIFY INSTALLATION MAY BE MADE IN COMPLETE ACCORDANCE WITH ALL PERTINENT CODES AND REGULATIONS. IN THE EVENT OF DISCREPANCY, IMMEDIATELY NOTIFY THE PROFESSIONAL ENGINEER OF RECORD. DO NOT PROCEED WITH THE INSTALLATION IN AREAS OF DISCREPANCY UNTIL ALL SUCH DISCREPANCIES HAVE BEEN FULLY RESOLVED.

IT IS NOT THE INTENT OF THE DRAWINGS THAT EXISTING CONDITIONS BE ACCURATELY SHOWN. EXISTING MECHANICAL WORK IS SHOWN TO LIMITED EXTENT ON DRAWINGS AND IS SHOWN FOR GENERAL REFERENCE ONLY. LOCATIONS AND INFORMATION WERE DERIVED FROM CURSORY SITE VISUAL OBSERVATIONS OR FROM DOCUMENTS THAT WERE PREPARED FOR PREVIOUSLY INSTALLED WORK WHEN AVAILABLE.

THE WORK COVERED BY THESE SPECIFICATIONS SHALL CONSIST OF PROVIDING ALL NEW MATERIAL, LABOR, EQUIPMENT, AND SERVICES NECESSARY FOR A COMPLETE MECHANICAL INSTALLATION AS SPECIFIED HEREIN. WORK IN THIS SECTION INCLUDES, BUT IS NOT LIMITED TO THE FOLLOWING ITEMS:

- TOILET EXHAUST FANS
KITCHEN HOOD AND EXHAUST FAN
LOW VOLTAGE THERMOSTATS
DUCT
DAMPERS
DIFFUSERS, REGISTERS, AND LOUVERS

WHENEVER THE WORDS "CONTRACTOR" APPEAR ON MECHANICAL DRAWINGS OR IN THESE SPECIFICATIONS, IT SHALL REFER TO THE MECHANICAL SUB-CONTRACTOR. WHENEVER THE WORD "PROVIDE" APPEARS IN THESE DOCUMENTS, IT SHALL BE INTERPRETED TO MEAN "FURNISH AND INSTALL".

COORDINATE ALL WORK WITH THE OWNER TO MINIMIZE INTERRUPTION OF BUILDING OPERATION.

COORDINATE THE INSTALLATION OF MECHANICAL ITEMS WITH THE SCHEDULES FOR WORK OF ALL OTHER TRADES TO PREVENT UNNECESSARY DELAYS IN THE TOTAL WORK.

THIS CONTRACTOR SHALL VERIFY AND SATISFY HIMSELF THAT ALL EQUIPMENT FURNISHED WILL PROPERLY FIT IN THE SPACE PROVIDED, THAT IT WILL FUNCTION PROPERLY, AND THAT ALL PARTS OF EQUIPMENT REQUIRING SERVICE ARE READILY ACCESSIBLE.

ALL PIPING SHALL BE RUN PARALLEL OR PERPENDICULAR TO BUILDING WALLS AND FRAMING SYSTEM. ALL VERTICAL RUNS SHALL BE HELD AGAINST WALLS, COLUMNS, ETC., AS POSSIBLE TO PERMIT MAKING OF PIPE JOINTS.

CONTRACTOR SHALL PROVIDE A GUARANTEE IN WRITTEN FORM STATING THAT ALL WORK SHALL BE FREE OF DEFECTS OR ERRORS, AND ALL EQUIPMENT, MATERIALS, OR PARTS FOR A PERIOD OF ONE YEAR FROM THE DATE OF OWNER'S FINAL ACCEPTANCE AND SHALL REPAIR, REVISE OR REPLACE AT NO COST TO THE OWNER ANY SUCH DEFECTS OCCURRING WITHIN THE GUARANTEE PERIOD.

CONTRACTOR SHALL ALSO STATE IN WRITTEN FORM THAT ANY ITEMS OR OCCURRENCES ARISING DURING THE GUARANTEE PERIOD WILL BE ATTENDED TO IN A TIMELY MANNER AND WILL IN NO CASE EXCEED THREE (3) WORKING DAYS FROM DATE OF NOTIFICATION BY OWNER.

PROVIDE A COMPLETE INSTALLATION IN CONFORMANCE WITH THE FOLLOWING STANDARDS.

- AGA: AMERICAN GAS ASSOCIATION
ASHRAE: AMERICAN SOCIETY OF HEATING, REFRIGERATING AND AIR CONDITIONING ENGINEERS
NFPA: NATIONAL FIRE PROTECTION ASSOCIATION
SMACNA: SHEET METAL AND AIR CONDITIONING CONTRACTORS NATIONAL ASSOCIATION. STATEWIDE BUILDING CODE
INTERNATIONAL MECHANICAL CODE

CONTRACTOR SHALL DO ALL CUTTING AND PATCHING REQUIRED FOR INSTALLATION OF THIS WORK. ALL OPENINGS IN WALLS, FLOORS OR CEILINGS SHALL BE PROPERLY SEALED AND RESTORED IN KIND. FLASH AND COUNTERFLASH AT ROOF OPENINGS.

ALL EQUIPMENT SHALL BE LISTED AND LABELED, UNLESS OTHERWISE APPROVED.

ALL WIRING SHALL MEET THE REQUIREMENTS LISTED IN THE ELECTRICAL SPECIFICATIONS. ALL CONTROL AND INTERLOCK WIRING AND CONDUIT (120V OR 24V) SHALL BE BY THE MECHANICAL CONTRACTOR.

EQUIPMENT SHALL BE INSTALLED IN ACCORDANCE WITH THE CONDITIONS OF LISTING AND THE MANUFACTURER'S INSTALLATION INSTRUCTIONS AND THIS CODE.

CLEANING: THIS CONTRACTOR SHALL REMOVE FROM THE PREMISES ALL ACCUMULATION OF DIRT, DEBRIS, WASTE MATERIALS AND RUBBISH CAUSED BY HIS EMPLOYEES OR WORK, AT LEAST ONE A WEEK, EXCEPT THAT COMBUSTIBLE MATERIALS SHALL BE REMOVED DAILY.

DURING PROGRESS OF THE WORK, MAINTAIN ON DRAWINGS AT THE SITE, AN ACCURATE RECORD OF THE INSTALLATION OF THE MECHANICAL SYSTEM, INDICATING ALL ITEMS WHICH HAVE BEEN CHANGED OR ADDED.

APPLY FOR AND PAY FOR ALL PERMITS AND INSPECTIONS REQUIRED BY LOCAL AUTHORITY, FOR THE APPROVAL OF WORK.

A CERTIFICATE OF FINAL INSPECTION AND APPROVAL SHALL BE SUBMITTED WITH THE CONTRACTOR'S REQUEST FOR FINAL PAYMENT. NO FINAL PAYMENT WILL BE APPROVED WITHOUT THIS CERTIFICATE.

GUARANTEE ALL WORKMANSHIP, MATERIAL, AND EQUIPMENT AND REPLACE ANY FOUND DEFECTIVE WORK WITHOUT COST TO THE OWNER, FOR A PERIOD OF ONE YEAR AFTER FINAL ACCEPTANCE.

EXISTING CONDITIONS

DO NOT REUSE REMOVED MECHANICAL MATERIALS UNLESS SPECIFICALLY INDICATED ON DRAWINGS. EXISTING SYSTEMS MAY BE UTILIZED ONLY TO THE EXTENT INDICATED ON DRAWINGS.

IF REQUIRED TO ACCOMMODATE CONSTRUCTION RELATED ACTIVITIES TEMPORARILY REMOVE, STORE IN PROTECTED LOCATION ON SITE, AND REINSTALL CONFLICTING MECHANICAL EQUIPMENT, OR DEVICES THAT ARE TO REMAIN OR TO BE RELOCATED.

WHERE THE TERM "DEMOLITION" IS USED HEREIN, INTERPRET IT TO MEAN "DEMOLITION" OR "SELECTIVE DEMOLITION" WHERE APPLICABLE.

PROVIDE MECHANICAL DEMOLITION WORK AS REQUIRED TO ACCOMMODATE PROJECT DEMOLITION AND AS REQUIRED TO ACCOMMODATE NEW CONSTRUCTION. DISCONNECT AND REMOVE WORK TO BE ABANDONED, AND AS REQUIRED TO ACCOMMODATE WORK OF OTHER TRADES, IN AREAS AFFECTED BY THIS PROJECT.

LEGALLY DISPOSE OF MATERIALS TO SALVAGED OR RETAINED.

23 05 03 SUBMITTALS FOR MECHANICAL SYSTEMS

DESIGN BASIS MANUFACTURERS OF MATERIAL AND EQUIPMENT ARE SPECIFIED AND PLANS ARE DETAILED ACCORDING TO THIS MATERIAL. CONTRACTOR SHALL BASE HIS BID ON FURNISHING AND INSTALLING THIS MAKE OF MATERIAL AND EQUIPMENT.

AN ACCEPTABLE MANUFACTURER'S NAME AND MODEL NUMBER OF A PRODUCT MAY BE PROVIDED IN THESE DOCUMENTS. THIS IS THE EQUIPMENT INCLUDED DURING THE DESIGN PROCESS AND FORMS THE BASIS OF A STANDARD OF QUALITY. WHERE MORE THAN ONE MAKE OF MATERIAL OR EQUIPMENT IS SPECIFIED, THE CONTRACTOR SHALL STATE IN HIS BID WHICH MAKE HE PROPOSES TO FURNISH AND INSTALL. SHOP DRAWING APPROVAL SHALL BE OBTAINED PRIOR TO SHIPMENT OF EQUIPMENT.

VERIFY THE MODEL NUMBER OR PRODUCT IS STILL ACCURATE AND MEETS ALL REQUIREMENTS SHOWN ON THE DRAWINGS. IF THERE IS A DISCREPANCY BETWEEN THE REQUIREMENTS AND THE PRODUCT OR MODEL NUMBER, THE STRICTER OF THE TWO SHALL GOVERN.

SUBMIT SHOP DRAWINGS AND/OR PRODUCT DATA (ELECTRONIC COPIES) ON THE FOLLOWING ITEMS FOR REVIEW BEFORE FABRICATION OR SHIPMENT:

- TOILET EXHAUST FANS
KITCHEN HOOD AND EXHAUST FAN
LOW VOLTAGE THERMOSTATS
DUCT
DAMPERS
DIFFUSERS, REGISTERS, AND LOUVERS

MAINTENANCE MANUALS: THE MANUALS SHALL INCLUDE WIRING DIAGRAMS, MAINTENANCE AND OPERATING INSTRUCTIONS, PARTS LISTINGS, AND COPIES OF OTHER SUBMITTALS INDICATED FOR INCLUSION.

REVIEW AND CORRECTIONS OR COMMENTS MADE ON SHOP DRAWINGS, PRODUCT DATA, CATALOGS, CUT SHEETS, CHARTS, AND OTHER ITEMS DURING CONSTRUCTION PHASE SUBMITTAL REVIEW DO NOT RELIEVE CONTRACTOR FROM COMPLIANCE WITH REQUIREMENTS OF THE CONTRACT DOCUMENTS, FOR PROVIDING A COMPLETE AND FUNCTIONING PROJECT, NOR SHALL THEY RELIEVE CONTRACTOR FROM RESPONSIBILITY FOR DEVIATIONS OR ERRORS OF ANY SORT. THIS REVIEW IS FOR THE LIMITED PURPOSE OF CHECKING FOR CONFORMANCE WITH INFORMATION GIVEN AND THE DESIGN CONCEPT EXPRESSED IN THE CONTRACT DOCUMENTS. CONTRACTOR REMAINS RESPONSIBLE FOR DETERMINING THE ACCURACY AND COMPLETENESS OF OTHER DETAILS SUCH AS DIMENSIONS AND QUANTITIES, FOR SUBSTANTIATING INSTRUCTIONS FOR INSTALLATIONS, VERIFYING MATERIALS REQUIRED, OBTAINING FIELD MEASUREMENTS AND RELATED CRITERIA, COORDINATING WORK WITH OTHER DISCIPLINES AND PERFORMING WORK IN COMPLIANCE WITH THE

CONTRACT DOCUMENTS.

ANY CHANGES TO ITEMS SPECIFIED MUST BE SUBMITTED IN WRITING AS A SUBSTITUTION, WITH COMPLETE DOCUMENTATION OF PRICE DIFFERENTIAL AND EQUIPMENT DETAILS. ANY SUBSTITUTIONS PROVIDED SHALL BE REVIEWED AT MARQUE ENGINEERING'S HOURLY RATES. REVIEW SHALL BE PAID FOR BY THE CONTRACTOR TO MARQUE ENGINEERING AT NO COST TO THE OWNER. BY USING PRE-APPROVED SUBSTITUTIONS, THE CONTRACTOR ACCEPTS ALL RESPONSIBILITY AND ASSOCIATED COSTS FOR ALL REQUIRED MODIFICATIONS TO THE CONTRACT DOCUMENTS TO INCLUDE BUT NOT LIMITED TO MATERIAL OR EQUIPMENT COSTS FOR THEIR OR OTHER TRADES, AND ENSURING THAT SUBSTITUTED MATERIALS AND EQUIPMENT TO BE FURNISHED FIT INTO SPACE AVAILABLE.

EXTENSIVE REVISIONS NECESSITATED TO THE CONTRACT DOCUMENTS, OR SUBSTITUTION ACTIONS RELATED TO ANY SPECIFIED PRODUCT NOT ABLE TO BE PROVIDED DUE TO A FAILURE TO COMMENCE WORK, RELEASE PRODUCT OR COORDINATE CONSTRUCTION ACTIVITIES SHALL BE PROVIDED AT MARQUE ENGINEERING'S HOURLY RATES. COSTS SHALL BE BORN BY THE CONTRACTOR AT NO COST TO THE OWNER.

23 05 29 HANGERS AND SUPPORTS

SUPPORT ALL PIPING, DUCTWORK AND EQUIPMENT BY HANGERS OR BRACKETS. FURNISH STRUCTURAL STEEL MEMBERS WHERE REQUIRED TO SUPPORT PIPING AND EQUIPMENT. NO PORTION OF PIPING OR VALVES SHALL BE SUPPORTED BY EQUIPMENT.

DUCTWORK - SUPPORT BY MEANS OF HANGERS AS FOLLOWS:

Table with 2 columns: DUCT WIDTH, HANGER SIZE, TYPE MAX. SPACING. Values: 30 OR LESS, (16 GAUGE), 8

A PAIR OF HANGERS SHALL BE LOCATED AT EVERY TRANSVERSE JOINT AND ELSEWHERE ACCORDING TO THE TABLE.

23 05 93 HVAC SYSTEM TESTING, ADJUSTING AND BALANCING FOR HVAC

ALL SYSTEMS AND EQUIPMENT SHALL BE CAREFULLY ADJUSTED TO PROVIDE COMFORTABLE AND UNIFORM CONDITIONS IN EACH AND EVERY SPACE TO THE OWNER'S SATISFACTION. PROVIDE ANY REQUIRED DRIVES TO SATISFY QUANTITIES INDICATED. PROVIDE A CERTIFIED AIR BALANCE OF THE DIFFUSERS AND AIR HANDLERS.

AIR SYSTEM:

AIR BALANCE AND TESTING SHALL NOT BEGIN UNTIL THE SYSTEM HAS BEEN COMPLETED AND IS IN FULL WORKING ORDER. CONTRACTOR SHALL PUT ALL HEATING, VENTILATING AND AIR CONDITIONING SYSTEM AND EQUIPMENT INTO FULL OPERATION AND SHALL CONTINUE THE OPERATION OF SAME DURING EACH WORKING DAY OF TESTING AND BALANCING. CONTRACTOR SHALL SUBMIT WITHIN 30 DAYS AFTER RECEIPT OF CONTRACT, COPIES OF SUBMITTAL DATA FOR THE TESTING AND BALANCING OF THE AIR CONDITIONING, HEATING, AND VENTILATING SYSTEMS. THE AIR BALANCE AND TESTING AGENCY SHALL PROVIDE PROOF OF HAVING SUCCESSFULLY COMPLETED AT LAST FIVE PROJECTS OF SIMILAR SIZE AND SCOPE.

CONTRACTOR SHALL PROCURE THE SERVICES OF AN INDEPENDENT AIR BALANCE AND TESTING AGENCY, APPROVED BY THE ENGINEER, AND A MEMBER OF AABC OR NEBB, WHICH SPECIALIZES IN THE BALANCING AND TESTING OF HEATING VENTILATION AND AIR CONDITIONING SYSTEMS, TO BALANCE, ADJUST AND TEST AIR MOVING EQUIPMENT AND AIR DISTRIBUTION OR EXHAUST SYSTEMS AS HEREIN SPECIFIED.

ALL WORK BY THIS AGENCY SHALL BE DONE UNDER THE DIRECT SUPERVISION OF A QUALIFIED HEATING AND VENTILATING ENGINEER EMPLOYED BY THIS AGENCY. ALL INSTRUMENTS USED BY THIS AGENCY SHALL BE ACCURATELY CALIBRATED AND MAINTAINED IN GOOD WORKING ORDER.

23 07 13 DUCT INSTALLATION

INSULATE ALL SUPPLY, DIFFUSER PLENUMS, AND OUTSIDE AIR DUCTWORK OF ALL UNITS WITH OWENS CORNING "ALL SERVICE DUCT WRAP" TYPE 150 GLASS FIBER INSULATION UNLESS OTHERWISE NOTED. INSULATION SHALL BE 1-1/2" THICK (2" THICK FOR SUPPLY AND RETURN IN TRUSS SPACE), 1.5 PCF. DENSITY WITH FRK JACKET. 002 THICK REINFORCED ALUMINUM FOIL VAPOR BARRIER. INSULATION SHALL CONFORM TO NFPA 90A AND 90B PER ASTM E-84 FOR FLAME SPREAD AND SMOKE DEVELOPED RATING.

INSULATE ALL EXTERIOR SUPPLY AND RETURN DUCTWORK WITH RIGID FIBERGLASS BOARD INSULATION WITH OUTDOOR JACKET. INSULATION SHALL BE 2" THICK WITH A "K" VALUE OF 0.23 AT 75 F. INSTALL ON DUCTWORK USING IMPALE ANCHORS AND WIRES. SEAL VAPOR BARRIER WITH VAPOR BARRIER ADHESIVE.

PROVIDE INSULATION ON ALL CONCEALED SUPPLY, RETURN DUCTWORK. ALL LINERS, INSULATION AND ADHESIVES SHALL HAVE A FLAME SPREAD INDEX NOT MORE THAN 25 AND A SMOKE DEVELOPED INDEX OF NOT MORE THAN 50.

RIGID FIBERGLASS DUCTWORK INSULATION: GLASS FIBERS BONDED WITH A THERMOSETTING RESIN. COMPLY WITH ASTM C 612, TYPE IB, WITHOUT FACING AND WITH VAPOR BARRIER ALL-SERVICE JACKET MANUFACTURED FROM KRAFT PAPER, REINFORCING SCRIM, ALUMINUM FOIL, AND VINYL FILM. INSULATION SHALL HAVE A MINIMUM R VALUE AS REQUIRED BY CODE.

FLEXIBLE FIBERGLASS DUCTWORK INSULATION: GLASS FIBERS BONDED WITH A THERMOSETTING RESIN. COMPLY WITH ASTM C 553, TYPE II, WITHOUT FACING AND WITH VAPOR BARRIER ALL-SERVICE JACKET MANUFACTURED FROM KRAFT PAPER, REINFORCING SCRIM, ALUMINUM FOIL, AND VINYL FILM. INSULATION SHALL HAVE A MINIMUM R VALUE AS REQUIRED BY CODE.

VAPOR BARRIER MATERIAL FOR DUCTWORK: PAPER-BACKED ALUMINUM-FOIL, EXCEPT AS OTHERWISE INDICATED; STRENGTH AND PERMEABILITY RATING EQUIVALENT TO FACTORY-APPLIED VAPOR BARRIERS ON ADJOINING DUCTWORK INSULATION, WHERE AVAILABLE; WITH FOLLOWING ADDITIONAL CONSTRUCTION CHARACTERISTICS:

HIGH PUNCTURE RESISTANCE: LOW VAPOR TRANSMISSION (FOR DUCTS IN EXPOSED AREAS: MECH. ROOMS, ETC.) MODERATE PUNCTURE RESISTANCE: MEDIUM VAPOR TRANSMISSION (FOR DUCTS IN CONCEALED AREAS).

INSTALLATION IS NOT PERMITTED ABOVE DRYWALL CEILINGS AND INACCESSIBLE CEILINGS.

23 09 93 SEQUENCE OF OPERATION

PACKAGED ROOFTOP UNIT

STARTUP
THE UNIT SHALL OPERATE ON A 7 DAY/NIGHT PROGRAMMABLE THERMOSTAT. DURING STARTUP, THE FAN SHALL RUN WITH THE DAMPERS IN THE FULL RECIRCULATION POSITION. PROVIDE OCCUPIED CHANGEOVER SEQUENCE WITH OPTIMUM START FUNCTION. WHEN THE RETURN AIR TEMPERATURE REACHES OCCUPIED SETPOINT (ADJUSTABLE), THE MINIMUM OUTSIDE AIR DAMPER SHALL OPEN TO THE CONTROLLED MINIMUM OUTDOOR AIR POSITION.

SUPPLY FAN CONTROL
THE SUPPLY FAN SPEED SHALL BE CONSTANT AND SET TO THE REQUIRED CFM.

SPACE TEMPERATURE CONTROL
PROVIDE LOCAL WALL MOUNTED ROOM TEMPERATURE THERMOSTAT WITH DIGITAL DISPLAY OF ROOM TEMPERATURE AND SETPOINT (+/- DEG. F. ADJUSTABLE), AND OVERRIDE FEATURE.

MINIMUM OUTSIDE AIR CONTROL
DURING OCCUPIED MODE THE MINIMUM OUTSIDE AIR DAMPER SHALL BE OPEN. PROVIDE MOTORIZED OUTDOOR AIR DAMPER.

ECONOMIZER CONTROL
DRY BULB CONTROLLED ECONOMIZER: OPERATED TO AUTOMATICALLY USE OUTDOOR AIR FOR "FREE COOLING" WHEN OUTDOOR AIR TEMPERATURE IS AT ACCEPTABLE LEVELS. AUTOMATICALLY MODULATED OUTDOOR AND RETURN AIR DAMPERS MAINTAIN PROPER DISCHARGE AIR TEMPERATURE INTO THE CONDITIONED SPACE. ADJUSTABLE MINIMUM POSITION CONTROL IS STANDARD. ECONOMIZER SHALL HAVE POWERED OR BAROMETRIC RELIEF, AS SCHEDULED.

COOLING CONTROL
COOLING SHALL BE CONTROLLED TO MAINTAIN SPACE TEMPERATURE SETPOINT. ON A CALL FOR COOLING THE HEATING SHALL BE OFF. ON A FURTHER CALL FOR COOLING, ENABLE THE ECONOMIZER MODE. ON A FURTHER CALL FOR COOLING, DISABLE THE ECONOMIZER MODE AND THE MECHANICAL COOLING SHALL BE STAGED ON.

HEATING CONTROL
HEATING SHALL BE CONTROLLED TO MAINTAIN SPACE TEMPERATURE SETPOINT. ON A CALL FOR HEATING, THE MECHANICAL COOLING SHALL BE OFF. ON A FURTHER CALL FOR HEATING, THE ECONOMIZER MODE SHALL BE DISABLED. ON A FURTHER CALL FOR HEATING THE GAS HEATING SHALL BE STAGED ON.

SMOKE DETECTOR
WHEN THE SMOKE DETECTOR IS ALARMED, THE SYSTEM SHALL BE ALARMED AND THE AIR HANDLER SHALL FAIL SAFE WITH MANUAL RESET. ELECTRICAL CONTRACTOR SHALL FURNISH, HVAC CONTRACTOR SHALL MOUNT & ELECTRICAL CONTRACTOR SHALL WIRE A UL LISTED PHOTOELECTRIC SMOKE DETECTOR PER LOCAL CODE AUTHORITY HAVING JURISDICTION.

UNOCCUPIED MODE
DURING THE UNOCCUPIED MODE OF OPERATION, THE RTU SHALL GO INTO NIGHT SETBACK MODE. AT NIGHT SETBACK/SHUTDOWN THE RTU SHALL GO TO FAIL SAFE POSITION. FAIL SAFE POSITION IS DEFINED BY THE FOLLOWING: THE SUPPLY FAN IS OFF, THE OUTDOOR AIR INTAKE DAMPER IS CLOSED, THE HEATING IS OFF AND THE MECHANICAL COOLING IS OFF. THE SUPPLY FAN SHALL CYCLE IN CONJUNCTION WITH EITHER THE HEATING OR COOLING SYSTEM TO MAINTAIN A MINIMUM/MAXIMUM SPACE TEMPERATURE DEPENDING ON THE SEASON.

PRODIGY PPD1 MASTER, COOLING ONLY WITH HEAT/COOL CHANGEOVER, PRESSURE DEPENDANT
ON POWER UP THE DAMPER WILL CALIBRATE FULLY-OPEN FOR 2 MINUTES. THE SLAVES WILL FOLLOW THE MASTER CONTROL.

COOL SUPPLY AIR: ON AN INCREASE IN SPACE TEMPERATURE THE PRODIGY REGULATES THE THE DIFFUSER'S AIR DAMPER OPEN TO INCREASE THE FLOW OF COOL AIR. ON AN INCREASE OF SPACE TEMPERATURE GREATER THAN THE COOLING

PROPORTIONAL BAND, THE DAMPER POSITION (%) IS MAINTAINED AT ITS PRE-SELECTED MAXIMUM SETTING. ON A DECREASE IN SPACE TEMPERATURE THE PRODIGY REGULATES THE DIFFUSER'S AIR DAMPER CLOSED TO REDUCE THE FLOW OF COOL AIR. IF THE SPACE TEMPERATURE DECREASES TO LESS THAN THE COOLING PROPORTIONAL BAND, THE DAMPER POSITION (%) IS MAINTAINED AT THE PRE-SELECTED MINIMUM SETTING.

WARM SUPPLY AIR: ON A DECREASE IN SPACE TEMPERATURE THE PRODIGY REGULATES THE DIFFUSER'S AIR DAMPER OPEN TO INCREASE THE FLOW OF WARM AIR. ON A DECREASE OF SPACE TEMPERATURE GREATER THAN THE HEATING PROPORTIONAL BAND, THE DAMPER POSITION (%) IS MAINTAINED AT ITS PRE-SELECTED MAXIMUM SETTING. ON AN INCREASE IN SPACE TEMPERATURE THE PRODIGY REGULATES THE DIFFUSER'S AIR DAMPER TO REDUCE THE FLOW OF WARM AIR. IF THE SPACE TEMPERATURE INCREASES ABOVE THE HEATING PROPORTIONAL BAND, THE DAMPER POSITION (%) IS MAINTAINED AT THE PRE-SELECTED MINIMUM SETTING.

LOW VOLTAGE THERMOSTATS SHALL BE PROVIDED AND WIRED BY THE HVAC CONTRACTOR. ELECTRICAL CONTRACTOR SHALL PROVIDE 4" SQUARE X 1-1/2" DEEP WALL OUTLET BOXES (WITH SINGLE-GANG RINGS) FOR ALL THERMOSTATS/SENSORS. ELECTRICAL CONTRACTOR SHALL PROVIDE ONE 3/4" EMPTY CONDUIT FROM EACH THERMOSTAT/SENSOR LOCATION, TURNED OUT ABOVE ACCESSIBLE CEILINGS (IN JOIST SPACE OR AGAINST OVERHEAD SLAB/DECK). HVAC/TEMPERATURE CONTROL CONTRACTOR SHALL PROVIDE ALL OTHER NECESSARY CONDUIT, RACEWAY AND WIRING RELATED WORK. CONDUIT SHALL BE IDENTIFIED IN CEILING CAVITY AND SHALL BE PROVIDED WITH BUSHINGS AND DRAINS.

EXHAUST FANS SHALL BE TIED TO LIGHT SWITCH, WHICH SHALL BE FURNISHED, INSTALLED AND WIRED BY ELECTRICAL CONTRACTOR. WHEN ACTIVATED, EXHAUST FAN MOTOR DAMPER SHALL OPEN AND FAN SHALL START.

KITCHEN HOOD EXHAUST FANS: PROVIDE HEAT DETECTOR IN HOOD COLLAR INTERLOCKED TO FAN OPERATION. KITCHEN HOOD EXHAUST SYSTEM SHALL BE INITIATED BY THE HEAT DETECTOR. PROVIDE INDICATOR LIGHT ON FACE OF HOOD. AT STARTUP, ENERGIZE EXHAUST FAN MOTOR, INTERLOCK TO MAKEUP AIR SYSTEM (WHETHER DEDICATED MAKEUP AIR OR MAKEUP AIR FROM HVAC SYSTEM), SO THAT MAKEUP AIR IS PROVIDED WHENEVER EXHAUST FAN IS RUNNING. EXHAUST FAN SHALL RUN CONTINUOUSLY AT CONSTANT SPEED. AT SHUTDOWN, THE EXHAUST FAN SHALL STOP.

PROVIDE ALL CONTROLS AND WIRING FOR COMPLETE INTERLOCK AND OPERATION OF KITCHEN HOOD, EXHAUST FAN, ROOFTOP UNIT, ETC. AND ALL ASSOCIATED MOTOR DAMPERS.

ALL DUCT SMOKE DETECTORS, FOR SMOKE DETECTORS, WILL BE FURNISHED PROVIDED AND WIRED BY ELECTRICAL CONTRACTOR, INSTALLED BY THE HVAC CONTRACTOR, AND WIRED BY THE ELECTRICAL CONTRACTOR PER LOCAL CODES. HVAC CONTRACTOR WILL INTERLOCK FAN WITH SMOKE DETECTOR.

MOTOR OPERATED DAMPERS: ALL FRESH AIR INTAKES AND EXHAUST LOUVERS SHALL HAVE MOTOR OPERATED DAMPERS. DAMPERS SHALL BE LOW LEAK WITH BLADE AND EDGE SEALS. 24 V MOTOR OPERATED DAMPERS SHALL BE PROVIDED AND WIRED BY THE MECHANICAL CONTRACTOR, UNLESS OTHERWISE NOTED. PROVIDE ALL NECESSARY TRANSFORMERS, CONTACTORS, CONTROLS AND WIRING FOR INTERLOCKING EQUIPMENT TO MOTOR OPERATED DAMPERS.

23 22 00 CONDENSATE DRAIN PIPING
INSTALL TRAP AT EVAPORATOR COIL DRAIN, EXTEND DRAIN LINE FROM COIL TRAP TO DRAIN. PIPING SHALL BE STANDARD WEIGHT, PVC PIPE AND FITTINGS AND WITH JOINTS OF PVC SOLVENT CEMENT. PROVIDE CLEANOUTS THROUGHOUT RUN AND AT TOPS OF TRAPS.

23 30 00 AIR DISTRIBUTION SYSTEM
CEILING AIR DIFFUSERS:
SQUARE: SQUARE HOUSING, CORE OF SQUARE CONCENTRIC LOUVERS, SQUARE OR ROUND DUCT CONNECTION.

VAV DIFFUSER: THE VAV SQUARE PLAQUE DIFFUSER SHALL BE SUPPLIES TO DELIVER A 360 DEGREE RADIAL, HORIZONTAL AIR FLOW PATTERN. THE BACK CONE SHALL BE A ONE-PIECE DIE-FORMED DESIGN WITH SMOOTH, AERODYNAMICALLY DESIGNED SURFACES AND NO CORNER JOINTS.

CONSTRUCTION:
DIFFUSER CONSTRUCTION SHALL BE 24x24 STEEL WITH ONE-PIECE BACK PAN, AERODYNAMICALLY DESIGNED INNER CONE DAMPER ASSEMBLY, AND PLAQUE FACEPLATE.

A PLAQUE ASSEMBLY SHALL BE INCORPORATED AND SHALL DROP NO MORE THAN 1/4 INCH BELOW THE CEILING PLAN TO ASSURE PROPER AIR DISTRIBUTION PERFORMANCE

THE PLAQUE ASSEMBLY SHALL BE COMPLETELY REMOVABLE FROM THE DIFFUSER FACE TO ALLOW FOR FULL ACCESS TO ANY DAMPERS OR OTHER DUCTWORK COMPONENTS LOCATED NEAR THE DIFFUSER NECK.

POWER REQUIREMENTS:
THE VAV DIFFUSERS SHALL BE POWERED BY 24VAC, 3.0 VA PER UNIT, WITH SUPPLY POWER FREQUENCY: 60 HZ

MODULATING DAMPER ASSEMBLY:
THE MODULATING DAMPER ASSEMBLY SHALL HAVE THE FOLLOWING FEATURES:
• QUIET, ULTRA-LONG LIFE BRUSHLESS A DRIVE MOTOR
• DIRECT DRIVE SYSTEM WITHOUT GEARS, BELTS, OR LEVERS, RESULTING IN ZERO MAINTENANCE AND LONG LIFE

DIFFUSER SHALL BE SUPPLIED WITH A 120 VOLT 277 VOLT, 24 VAC 20 VA TRANSFORMER

A PRESSURE RELIEF COLLAR SHALL BE FITTED TO THE INLET COLLAR OF THE VAV DIFFUSER TO RELIEVE EXCESS STATIC PRESSURE ARISING FROM MODULATION OF THE AIR FLOW.

A WALL MOUNTED THERMOSTAT WILL PROVIDE ROOM TEMPERATURE SENSING AS WELL AS SET-POINT ADJUSTMENT FOR HEATING AND COOLING.

LINEAR: EXTRUDED ALUMINUM CONTINUOUS SLOT, SINGLE OR MULTIPLE.

DIFFUSER MOUNTINGS:
SURFACE MOUNT: DIFFUSER SHALL HAVE ROLLED EDGE BELOW FINISHED CEILING FOR SURFACE MOUNTING OR DIFFUSER SHALL BE FURNISHED WITH ACCESSORY PLASTER FRAME.

LAY-IN: DIFFUSER HOUSING SIZED TO FIT BETWEEN CEILING EXPOSED SUSPENSION TEE BARS AND REST ON TOP SURFACE OF TEE BAR.

DIFFUSER ACOUSTIC PERFORMANCE: NC LESS THAN OR EQUAL TO 30

DIFFUSER ACCESSORIES: PLASTER RING; PERIMETER RING DESIGNED TO ACT AS PLASTER STOP AND DIFFUSER ANCHOR.

DIFFUSER FINISHES: WHITE ENAMEL; SEMI-GLOSS WHITE ENAMEL PRIME FINISH.

CEILING AND WALL REGISTERS & GRILLES:
STEEL CONSTRUCTION: MANUFACTURER'S STANDARD STAMPED SHEET STEEL FRAME AND ADJUSTABLE BLADES.

REGISTER AND GRILLE FINISHES: WHITE ENAMEL; SEMI-GLOSS WHITE ENAMEL PRIME FINISH.

REGISTER AND GRILLE ACOUSTIC PERFORMANCE: NC LESS THAN OR EQUAL TO 30

23 31 13 METAL DUCTS
CONSTRUCTION, INSTALLATION AND SUPPORT OF ALL DUCTWORK SHALL CONFORM TO THE LATEST EDITION OF SMACNA "HVAC DUCT CONSTRUCTION STANDARD - METAL AND FLEXIBLE".

ASSEMBLE AND INSTALL DUCTWORK IN ACCORDANCE WITH RECOGNIZED INDUSTRY PRACTICES TO ACHIEVE AIR-TIGHT (5% LEAKAGE FOR SYSTEMS RATED 3" AND UNDER; 1% FOR SYSTEMS RATED OVER 3") AND NOISELESS (NO OBJECTIONABLE NOISE) SYSTEMS. INSTALL EACH RUN WITH MINIMUM NUMBER OF JOINTS. ALIGN DUCTWORK ACCURATELY AT CONNECTIONS, WITHIN 1/8" MISALIGNMENT TOLERANCE AND WITH INTERNAL SURFACES SMOOTH.

SUPPORT VERTICAL DUCTS AT EVERY FLOOR. SUPPORT DUCT WITH APPROVED HANGERS AT INTERVALS NOT EXCEEDING 10 FEET.

DUCTS SHALL BE GALVANIZED SHEET METAL OF STANDARD GAUGES. DUCTWORK SHALL HAVE A MINIMUM THICKNESS OF 24 GAUGE. ALL DUCT ELBOWS SHALL BE EITHER FULL RADIUS OR WITH TURNING VANES.

WHERE DUCTWORK IS INDICATED TO BE EXPOSED IN OCCUPIED SPACES, PROVIDE MATERIALS WHICH ARE FREE FROM VISUAL IMPERFECTIONS INCLUDING PITTING, SEAM MARKS, ROLLER MARKS, STAINS AND DISCOLORATIONS, AND OTHER IMPERFECTIONS, INCLUDING THOSE WHICH WOULD IMPAIR PAINTING.

EXPOSED DUCTWORK WHICH IS TO BE PAINTED SHALL HAVE PAINT GRIP APPLIED.

PROVIDE VOLUME DAMPERS IN ALL BRANCH DUCTS OR AS REQUIRED FOR BALANCING TO REQUIRED AIR FLOWS.

PROVIDE RADIUS TYPE FITTINGS FABRICATED OF MULTIPLE SECTIONS WITH MAXIMUM 15 DEG. CHANGE OF DIRECTION PER SECTION. UNLESS DETAILED OTHERWISE, USE 45 DEG. LATERALS AND 45 DEG. ELBOWS FOR BRANCH TAKEOFF CONNECTIONS. WHERE 90 DEG. BRANCHES ARE INDICATED, PROVIDE CONICAL TYPE TEES.

PROVIDE DUCT SEALANT AND/OR CEMENT WHICH IS NON-HARDENING, NON-MIGRATING MASTIC OR OF LIQUID ELASTIC SEALANT, TYPE APPLICABLE FOR FABRICATION/INSTALLATION DETAIL, AS COMPOUNDED AND RECOMMENDED BY MANUFACTURER SPECIFICALLY FOR SEALING JOINTS AND SEAMS IN DUCTWORK.

FLEXIBLE DUCTS SHALL EITHER BE SPIRAL-WOUND SPRING STEEL WITH FLAMEPROOF VINYL SHEATHING OR CORRUGATED ALUMINUM. THE MAXIMUM LENGTH OF FLEX DUCT ON THE SUPPLY EQUALS 5 FEET. FLEX IS NOT ALLOWED FOR RETURN, RELIEF OR EXHAUST APPLICATIONS.

FLEXIBLE DUCTS SHALL CONFORM TO THE REQUIREMENTS OF UL 181 FOR CLASS 0 OR CLASS 1 FLEXIBLE AIR DUCTS AND SHALL BE SO IDENTIFIED.

WHERE INSTALLED IN UNCONDITIONED SPACES OTHER THAN RETURN AIR PLENUMS, PROVIDE 1" THICK 1-1/2 LB. CONTINUOUS FLEXIBLE FIBERGLASS SHEATH WITH VINYL VAPOR BARRIER JACKET.

SHOP FABRICATE DUCTWORK IN 4, 8, 10 OR 12-FT LENGTHS, OR REQUIRED TO COMPLETE RUNS.

FABRICATE DUCTWORK WITH DUCT LINER IN EACH SECTION OF DUCT WHERE INDICATED. LAMINATE LINER TO INTERNAL SURFACES OF DUCT IN ACCORDANCE WITH INSTRUCTIONS BY MANUFACTURERS OF LINING AND ADHESIVE, AND FASTEN WITH MECHANICAL FASTENERS. DUCT LINER TO BE 3-LB DENSITY FOR ACOUSTIC REQUIREMENTS 1" THICK OR AS NOTED. SIZE OF DUCTWORK SHOWN ON THE DRAWINGS IS FREE NET AREA, OUTSIDE DIMENSION OF DUCTS WILL NEED TO BE INCREASED IF LINED DUCT IS USED.

DUCT LINER SHALL BE OF FIBROUS GLASS OF THICKNESS INDICATED. 3-LB DENSITY. ALL LINERS, INSULATION AND ADHESIVES SHALL HAVE A FLAME SPREAD INDEX NOT MORE THAN 25 AND A SMOKE DEVELOPED INDEX OF NOT MORE THAN 50.

23 33 13 DAMPERS

DAMPERS WITH LOCKING DEVICE, WHERE ACCESSIBLE, SHALL BE RUSKIN MD-35. OPPOSED BLADE FOR RECTANGULAR DUCTS 12 INCHES AND ABOVE, AND MODEL MD-25 PARALLEL BLADE FOR DUCTS 10 INCHES AND BELOW, AND MODEL MDRS-25 FOR ROUND DUCTS. INSTALL PER MANUFACTURER'S INSTRUCTIONS. SINGLE BLADE ROUND DAMPERS WITH LOCKING DEVICE SHALL BE IN SPIN-IN COLLARS.

FIRE DAMPERS SHALL BE RUSKIN MODEL 1BD, STYLE B WITH BLADE PACKAGE OUT OF AIR STREAM. HORIZONTAL, INSTALL WHERE INDICATED ON DRAWINGS AND AS REQUIRED BY AUTHORITY HAVING LOCAL JURISDICTION.

ELECTRIC MOTORIZED DAMPER SHALL BE SIZED TO OPERATE WITH SUFFICIENT RESERVE POWER TO PROVIDE SMOOTH MODULATING ACTION OR TWO-POSITION ACTION. INSTALL PER MANUFACTURER'S INSTRUCTIONS.

23 38 13.00 - COMMERCIAL KITCHEN HOODS AND DUCTWORK

TYPE I HOOD

INSPECTION
GENERAL: EXAMINE AREAS AND CONDITIONS UNDER WHICH EQUIPMENT IS TO BE INSTALLED. DO NOT PROCEED WITH WORK UNTIL UNSATISFACTORY CONDITIONS HAVE BEEN CORRECTED.

INSTALLATION
COORDINATE WORK WITH WORK OF ROOFING, WALLS, AND CEILINGS, AS NECESSARY FOR PROPER INTERFACING. DUCT CONNECTIONS TO BE PROVIDED BY THE HVAC CONTRACTOR.

ELECTRICAL WIRING: INSTALL ELECTRICAL DEVICES FURNISHED BY MANUFACTURER BUT NOT SPECIFIED TO BE FACTORY-MOUNTED. FURNISH COPY OF MANUFACTURER'S WIRING DIAGRAM SUBMITTAL TO ELECTRICAL INSTALLER.

VERIFY THAT ELECTRICAL WIRING INSTALLATION IS IN ACCORDANCE WITH MANUFACTURER'S SUBMITTAL AND INSTALLATION REQUIREMENTS OF DIVISION-16 SECTIONS.

ENSURE THAT ROTATION IS IN DIRECTION INDICATED AND INTENDED FOR PROPER PERFORMANCE.

DO NOT PROCEED WITH CENTRIFUGAL FAN START-UP UNTIL WIRING INSTALLATION IS ACCEPTABLE TO FAN INSTALLER.

FIELD QUALITY CONTROL
TESTING: AFTER INSTALLATION OF HOOD EXHAUST SYSTEM HAS BEEN COMPLETED, TEST EACH SYSTEM TO CORRECT MAJOR OPERATION OF UNITS AT PERFORMANCE REQUIREMENTS SPECIFIED. WHEN POSSIBLE, FIELD DEMONSTRATE PROPER FUNCTIONING UNITS, THEN TEST TO DEMONSTRATE COMPLIANCE. REPLACE UNITS WHICH CANNOT BE SATISFACTORILY CORRECTED.

PROVIDE TESTING, PERMITS AND APPROVALS AS REQUIRED BY STATE AND LOCAL AUTHORITIES.

ADJUSTING AND CLEANING
CLEAN FACTORY-FINISHED SURFACES.
REPAIR ANY MARRED OR SCRATCHED SURFACES.

TYPE I KITCHEN GREASE DUCT SPECIFICATION
FURNISH SINGLE WALL 16 GAUGE CARBON STEEL DUCTWORK WITH CONTINUOUS LIQUID TIGHT WELDS. ALL DUCTWORK SHALL BE WRAPPED WITH A FIRE RESISTIVE MATERIAL. THE DUCT WRAP SYSTEM SHALL BE UL LISTED PER ASTM E 2336 FOR ZERO CLEARANCE TO COMBUSTIBLES AND SHALL MAINTAIN A FLAME/SMOKE RATINGS LESS THAN 25/50.

THE TERMINATION OF KITCHEN EXHAUST OUTLETS SHALL NOT BE LESS THAN 10 FEET HORIZONTALLY FROM PARTS OF THE SAME OR CONTIGUOUS BUILDINGS, ADJACENT PROPERTY LINES AND AIR INTAKES.

OUTLET SHALL NOT BE LESS THAN 10 FEET VERTICALLY ABOVE ADJOINING GRADE LEVEL AND 40" ABOVE THE ROOF LEVEL.

THE EXHAUST FAN SHALL BE INSTALLED A MINIMUM OF 10'-0" FROM