

Report By:

**National TAB
1329 E. KEMPER ROAD
SUITE 4210
CINCINNATI, OH 45246**



**Report: Gladstone Fire Station (Gladstone, MO)
Function: Test, Adjust, & Balance
Date: 09/28/2022**

**PROJECT
Gladstone Fire Station**

6569 PROSPECT AVE

KANSAS CITY, MO 64119

Client

QUALITY PLUMBING INC
1731 HOWELL ST

N KANSAS CITY, MO 64116

National TAB

Project: Gladstone Fire Station

Table Of Contents

Section	Page #
Certification Page	3
Summary	4
AHU/RTU	5
Split Sys Furnace	15
Temperature Readings	17
Energy Recovery Unit	18
ERV Static Pressures	21
FAN - Exhaust	22
GRD Layout	28
Equipment Calibrations	31
Abbreviations	32



CERTIFICATION



PROJECT: GLADSTONE FIRE STATION

The data presented in this report is a record of system measurements and final adjustments that have been obtained in accordance with the current edition of the NEBB Procedural Standard for Testing, Adjusting and Balancing of Environmental Systems. The measurements shown, and the information given, in this report are certified to be accurate and complete, at the time and date information was gathered. Any variances from design quantities, which exceed NEBB tolerances, are noted in the TAB report project summary.

NEBB TAB FIRM: National TAB - Kansas City
REGISTRATION NO: 3768
CERTIFIED BY: Will Turnbough
DATE: 2/1/2023

Submitted and Certified by:

NEBB TAB FIRM: National TAB - Kansas City
TAB PROFESSIONAL: Will Turnbough
REGISTRATION NO: CP-24289
CERTIFICATION EXP: 12/31/2023

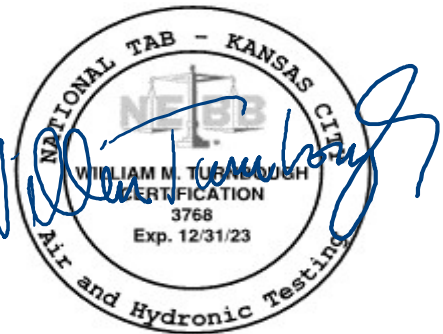

Project Summary

RTU's (Roof Top Units) w/ Diffusers

Each of the RTU's were measured at their terminal devices or via traverse to establish a total flow for that unit. Each RTU was adjusted to within tolerance of the engineer's design flow. Each outlet was then adjusted to within tolerance of the design flow. Outside air was measured by reading the intake air opening with a velocity grid and multiplying by the free area. The outside air damper was adjusted until the airflow was within the design requirements. Any equipment that fell outside of that tolerance is noted throughout the report.

AHU's w/ Diffusers

Each of the AHU's were measured at their terminal devices or via traverse to establish a total flow for that unit. Each AHU was adjusted to within tolerance of the engineer's design flow. Each outlet was then adjusted to within tolerance of the design flow. If provided with outside air, the flow was measured via traverse. The outside air damper was adjusted until the airflow was within the design requirements. Any equipment that fell outside of that tolerance is noted throughout the report.

ERV

The ERV has a supply and exhaust fan with a heat wheel. The supply fan was measured by reading the intake air hood with a velocity grid and multiplying by the free area. The ductwork in the space is above hard ceiling and was not accessible for measurement. The exhaust fan was measured by reading each grille with a flow hood. The flow was also measured at the discharge for reference however this reading is not as reliable. Majority of the ductwork is above hard ceiling and not accessible for inspection.

Ceiling Exhaust Fans

The ceiling exhaust fans were measured using a flow hood. If speed adjustment was provided, the fan speed was adjusted to within design tolerance. Any equipment that fell outside of this tolerance is noted throughout the report.

National TAB

Project: Gladstone Fire Station
System/Unit: AHU/RTU



Comfort. Under control.

Asset: RTU-1

AREA:110

Unit Data		
	Design	Actual
MFG	TRANE	TRANE
Serial Num	-	221810702D
Model Num	BELT	YHD150G3RHD4HX2
Configuration	VERTICAL	VERTICAL
Num OA Filters 1	-	1
OA Filter Size 1	-	59.5x17
Num PreFilter 1	-	4/4
PreFilter Size 1	-	20"x25"x2"/20"x20"x2"

Test Data		
	Design	Actual
SF CFM	4185	4198
SF RPM	750	584
RA CFM	3830	3875
OA CFM	355	323
RL Voltage	-	209
RL Amperage	-	6.8
OA Damper Position	-	0.0625"

Motor Data		
	Design	Actual
Motor MFG	-	MARATHON
Frame	-	56HZ
Horsepower	-	3.0
Motor Rpm	-	1740
Phase	-	3
Rated Voltage	-	208-230
Rated Amperage	-	9.4-9.2
Service Factor	-	NL

Performance Data		
	Design	Actual
MA Plenum SP	-	-0.16"
Fan Suction SP	-	-0.30"
Fan Discharge SP	-	0.39"
Total ESP	1.00	0.55"
Fan Total SP	-	0.69"

Drive Data		
	Design	Actual
Motor Sheave Size	-	4"
Motor Bore Size	-	7/8"
Motor Sheave SetPt	-	VFD
Fan Sheave Size	-	10.5"
Fan Sheave Bore	-	1-3/16"
Belt CL Distance	-	TENSIONER IN PLACE
Num of Belts	-	1
Belt Size	-	BX68

Completed By: Will Turnbough

Notes: RETURN AIR DAMPER POSITION = 95% OPEN / BAROMETRIC RELIEF DAMPER = CLOSED

National TAB

Project: Gladstone Fire Station

AHU/RTU



Comfort. Under control.

Diffuser Supply (GRD)

RTU-1/110

Asset								
Asset Name	Location	Type	Size	DESIGN CFM	AK	CFM(1)	CFM(2)	FINAL CFM
SGRD1	880	C	8"	200	1	252	282	216
SGRD2	880	C	8"	200	1	236	229	205
SGRD3	880	C	8"	200	1	182	215	215
SGRD4	880	C	8"	200	1	187	220	201
SGRD5	103	D	10"	295	1	364	319	311
SGRD6	103	D	10"	295	1	376	290	305
SGRD7	103	D	10"	295	1	307	347	280
SGRD8	103	D	10"	295	1	315	343	275
SGRD9	103	D	10"	295	1	267	295	278
SGRD10	103	D	10"	295	1	269	287	273
SGRD11	103	D	10"	295	1	284	305	285
SGRD12	103	D	10"	295	1	310	323	301
SGRD13	102	C	8"	150	1	122	140	144
SGRD14	102	C	8"	150	1	126	161	158
SGRD15	102	C	8"	150	1	106	102	149
SGRD16	102	C	8"	150	1	159	122	155
SGRD17	157	C	10"	300	1	317	311	316
SGRD18	106	D	6"	125	1	261	120	131

Completed By: Michael Gabbert on

National TAB

Project: Gladstone Fire Station
System/Unit: AHU/RTU



Comfort. Under control.

Asset: RTU-2

AREA:113

Unit Data		
	Design	Actual
MFG	TRANE	TRANE
Serial Num	-	221610161L
Model Num	DD	YHC067E3RHA27D6E1A10600A
Configuration	VERTICAL	VERTICAL
Num OA Filters 1	-	1 METAL MESH
OA Filter Size 1	-	15"X36"
Num PreFilter 1	-	4
PreFilter Size 1	-	16"X25"X2"

Test Data		
	Design	Actual
SF CFM	1600	1544
RA CFM	1405	1257
OA CFM	195	303
RL Voltage	-	209/209/211
RL Amperage	-	4.1/4.1/4.2
OA Damper Position	-	CLOSED HI / 0.5" LOW

Motor Data		
	Design	Actual
Motor MFG	-	GENTEQ
Frame	-	NL
Horsepower	-	1.0
Motor Rpm	-	1030
Phase	-	1
Rated Voltage	-	208/230
Rated Amperage	-	9.0
Service Factor	-	NL

Performance Data		
	Design	Actual
MA Plenum SP	-	-0.31"
Fan Suction SP	-	-0.62"
Fan Discharge SP	-	0.81"
Total ESP	1.00	1.12"
Fan Total SP	-	1.43"

Completed By: Jacob Davidson

Notes: RETURN TRIP NOTES 1/25: OA at intake is above design with the damper fully closed. / RETURN AIR DAMPER POSITION = 18" OPEN / BAROMETRIC RELIEF DAMPER = CLOSED

National TAB

Project: Gladstone Fire Station

AHU/RTU



Comfort. Under control.

Diffuser Supply (GRD)

RTU-2/113

Asset								
Asset Name	Location	Type	Size	DESIGN CFM	AK	CFM(1)	CFM(2)	FINAL CFM
SGRD1	110	D	10"	245	1	618	301	238
SGRD2	110	D	10"	245	1	389	239	262
SGRD3	109A	D	8"	145	1	110	137	144
SGRD4	109A	A	6"X6"	65	1	249	60	66
SGRD5	108	D	12"	230	1	65	108	209
SGRD6	111	D	6"	150	1	95	141	164
SGRD7	112	D	8"	185	1	97	164	160
SGRD8	113	D	8"	170	1	97	145	143
SGRD9	149	D	6"	90	1	116	163	83
SGRD10	148	D	6"	75	1	76	159	75

Diffuser Ret/Exh (GRD)

RTU-2/113

Asset							
Asset Name	Type	Size	DESIGN CFM	AK	CFM(1)	CFM(2)	FINAL CFM
EGRD1	B	10"X10"	345	1	15	161	111
EGRD2	B	8"X8"	150	1	100	102	56
EGRD3	B	8"X8"	185	1	86	81	51
EGRD4	B	8"X8"	170	1	101	110	83

Completed By: Michael Gabbert on

Asset	Notes
SGRD4	1/25 RETURN TRIP NOTES: DUCTWORK AND DAMPERS ARE ABOVE HARD CEILING. UNABLE TO ACCESS TO REDUCE AIRFLOW.

National TAB

Project: Gladstone Fire Station
System/Unit: AHU/RTU



Comfort. Under control.

Asset: RTU-3

AREA:120

Unit Data		
	Design	Actual
MFG	TRANE	TRANE
Serial Num	-	221610193L
Model Num	DD	YHC102F3RHA27D6E1A10600A
Configuration	VERTICAL	VERTICAL
Num OA Filters 1	-	1 METAL MESH
OA Filter Size 1	-	15"X36"
Num PreFilter 1	-	4
PreFilter Size 1	-	20"x25"x2"

Test Data		
	Design	Actual
SF CFM	2750	3009
RA CFM	2150	2431
OA CFM	600	578
RL Voltage	-	208/209/209
RL Amperage	-	2.7/2.7/2.8
OA Damper Position	-	1" high / 1.75" low

Motor Data		
	Design	Actual
Motor MFG	-	GENTEQ
Frame	-	NL
Horsepower	-	2.75
Motor Rpm	-	1232
Phase	-	3
Rated Voltage	-	208
Rated Amperage	-	7.3
Service Factor	-	NL

Performance Data		
	Design	Actual
MA Plenum SP	-	-0.25"
Fan Suction SP	-	-0.47"
Fan Discharge SP	-	0.42"
Total ESP	1.00	0.67"
Fan Total SP	-	0.89"

Completed By: Jacob Davidson

Notes: RETURN AIR DAMPER POSITION = 15" OPEN / BAROMETRIC RELIEF DAMPER = CLOSED

National TAB

Project: Gladstone Fire Station

AHU/RTU



Comfort. Under control.

Diffuser Supply (GRD)

RTU-3/120

Asset								
Asset Name	Location	Type	Size	DESIGN CFM	AK	CFM(1)	CFM(2)	FINAL CFM
SGRD1	118	D	10"	400	1	593	413	380
SGRD2	118	D	10"	400	1	632	433	372
SGRD3	119	D	10"	400	1	694	495	436
SGRD4	119	D	10"	335	1	800	591	526
SGRD5	119	D	10"	325	1	742	552	473
SGRD6	120	D	14"X14"	290	1	651	460	262
SGRD7	120	C	10"	300	1	488	382	303
SGRD8	120	C	10"	300	1	397	306	257

Completed By: Michael Gabbert on

Asset	Notes
SGRD4	1/25 RETURN TRIP NOTES: DUCTWORK ABOVE HARD CEILING. DAMPERS NOT ACCESSIBLE.

National TAB

Project: Gladstone Fire Station
System/Unit: AHU/RTU



Comfort. Under control.

Asset: RTU-4

AREA:144

Unit Data		
	Design	Actual
MFG	TRANE	TRANE
Serial Num	-	221610159L
Model Num	DD	YHC047E3RMA27D6E1A10600A
Configuration	VERTICAL	VERTICAL
Num OA Filters 1	-	1 METAL MESH
OA Filter Size 1	-	15"X36"
Num PreFilter 1	-	4
PreFilter Size 1	-	16"X25"X2"

Test Data		
	Design	Actual
SF CFM	1475	1454
RA CFM	1155	1146
OA CFM	320	308
RL Voltage	-	209
RL Amperage	-	0.6
OA Damper Position	-	0.5" high / 1.25" low

Motor Data		
	Design	Actual
Motor MFG	-	[1]
Frame	-	[1]
Horsepower	-	1.0
Motor Rpm	-	1026
Phase	-	1
Rated Voltage	-	208
Rated Amperage	-	7.3
Service Factor	-	NL

Performance Data		
	Design	Actual
MA Plenum SP	-	-0.13
Fan Suction SP	-	-0.31
Fan Discharge SP	-	0.33"
Total ESP	1.00	0.44"
Fan Total SP	-	0.64"

Completed By: Jacob Davidson

Notes: RETURN AIR DAMPER POSITION = 12" OPEN (LOW), 15" OPEN (HIGH) / BAROMETRIC RELIEF DAMPER = CLOSED

National TAB

Project: Gladstone Fire Station

AHU/RTU



Comfort. Under control.

Diffuser Supply (GRD)

RTU-4/144

Asset								
Asset Name	Location	Type	Size	DESIGN CFM	AK	CFM(1)	CFM(2)	FINAL CFM
SGRD1	141	D	8"	205	1	223	298	225
SGRD2	142	A	6"X6"	85	0.12	69	102	80
SGRD3	143	A	6"X6"	55	1	56	66	51
SGRD4	140	A	6"X6"	50	1	79	73	55
SGRD5	144	A	6"X6"	70	1	90	101	77
SGRD6	138	D	6"	170	1	90	111	87
SGRD7	136	A	6"X6"	60	1	67	78	61
SGRD8	121	D	10"	245	0.43	425	308	240
SGRD9	121	D	10"	245	0.43	492	338	264
SGRD10	135	A	6"X6"	50	1	64	72	54
SGRD11	134	A	6"X6"	60	1	64	87	66
SGRD12	133	A	6"X6"	60	1	69	86	64
SGRD13	132	A	6"X6"	60	1	77	87	66
SGRD14	131	A	6"X6"	60	1	80	82	64

Diffuser Ret/Exh (GRD)

RTU-4/144

Asset							
Asset Name	Type	Size	DESIGN CFM	AK	CFM(1)	CFM(2)	FINAL CFM
EGRD1	B	10"X10"	395	1	111	111	111
EGRD2	B	6"X6"	70	1	51	51	51

Completed By: Michael Gabbert on

Asset	Notes
SGRD4	1/25 - RETURN TRIP NOTE: DAMPER FOUND 25% OPEN. OPENED 100% AND AIRFLOW AND 54 CFM. OPENED DAMPER 100% AND IT INCREASED ONLY SLIGHTLY TO 65 CFM. 6" DUCT RUN. NOT POSSIBLE TO INCREASE AIRFLOW WITHOUT DEGRADING OVERALL UNIT PERFORMANCE.
SGRD5	1/25 - RETURN TRIP NOTE: AIRFLOW FOUND UNCHANGED. VERIFIED THE DAMPER IS 100% OPEN. THERE ARE (4) 90 DEGREE TRANSITIONS THAT HAD TO BE INSTALLED IN THE RUN DUE TO INTERFERENCE ABOVE THE CEILING.

National TAB

Project: Gladstone Fire Station
System/Unit: AHU/RTU



Comfort. Under control.

Asset: RTU-5

AREA:132

Unit Data		
	Design	Actual
MFG	TRANE	TRANE
Serial Num	-	221610195L
Model Num	DD	YHC092F3RMA27D6E1A10600A
Configuration	VERTICAL	VERTICAL
Num OA Filters 1	-	1 METAL MESH
OA Filter Size 1	-	15"X36"
Num PreFilter 1	-	4
PreFilter Size 1	-	20"x25"x2"

Test Data		
	Design	Actual
SF CFM	2400	2445
RA CFM	1850	1869
OA CFM	550	576
RL Voltage	-	209/209/208
RL Amperage	-	6.0/6.2/6.3
OA Damper Position	-	1" high / 3" low

Performance Data		
	Design	Actual
MA Plenum SP	-	-0.11"
Fan Suction SP	-	-0.30"
Fan Discharge SP	-	0.31"
Total ESP	1.00	0.42"
Fan Total SP	-	0.61"

Motor Data		
	Design	Actual
Motor MFG	-	UTO
Frame	-	UTO
Horsepower	-	2.75
Motor Rpm	-	1134
Phase	-	3
Rated Voltage	-	208
Rated Amperage	-	7.3
Service Factor	-	UTO

Completed By: Jacob Davidson

Notes: RETURN AIR DAMPER POSITION = 7" OPEN (LOW), 15" OPEN (HIGH) / BAROMETRIC RELIEF DAMPER = CLOSED

National TAB

Project: Gladstone Fire Station

AHU/RTU



Comfort. Under control.

Diffuser Supply (GRD)

RTU-5/132

Asset								
Asset Name	Location	Type	Size	DESIGN CFM	AK	CFM(1)	CFM(2)	FINAL CFM
SGRD1	122	D	8"	175	1	345	180	164
SGRD2	130	D	14"X14"	330	1	67	376	313
SGRD3	129	D	14"X14"	230	1	584	298	252
SGRD4	128	D	14"X14"	230	1	808	416	228
SGRD5	127	D	14"X14"	230	1	536	281	231
SGRD6	126	D	14"X14"	230	1	731	416	242
SGRD7	125	D	14"X14"	230	1	332	185	238
SGRD8	124	D	14"X14"	230	1	511	277	229
SGRD9	123	D	14"X14"	330	1	742	417	348
SGRD10	122	D	8"	185	1	443	252	200

Completed By: Michael Gabbert on

National TAB

Project: Gladstone Fire Station

System/Unit: Split Sys Furnace



Comfort. Under control.

Asset: AC-2

AREA:

Unit Data		
	Design	Actual
MFG	TRANE	TRANE
Model Num	4TXC	4TTA7036A3
Serial Num	-	UTO
Configuration	-	HORIZONTAL
Filter Size Size 1	-	16"X24"X1

Test Data		
	Design	Actual
SF CFM	975	1022
RL Voltage	-	NA
RL Amperage	-	NA
RA CFM	-	966
OA CFM	160	56

Motor Data		
	Design	Actual
Motor MFG	-	NL
Frame	-	NL
Horsepower	0.75	0.75
Motor Rpm	-	1075
Phase	3	1
Voltage	208	208-230
Amperage	-	15.0

Performance Data		
	Design	Actual
Suction ESP	-	-0.05
Discharge ESP	-	0.06
Total ESP	0.75	0.08

Completed By: Jacob Davidson

Notes: 1/25 RETURN TRIP NOTES- OA DAMPER FULLY OPEN. NO RETURN DAMPER.

National TAB

Project: Gladstone Fire Station

Split Sys Furnace



Comfort. Under control.

Diffuser Supply (GRD)

AC-2/

Asset							
Asset Name	Location	Type	Size	DESIGN CFM	CFM(1)	FINAL CFM	% to design
AC-2-SGRD1	116	C	10"	280	298	302	107.9
AC-2-SGRD2	116	C	10"	280	269	287	102.5
AC-2-SGRD3	116	C	10"	280	168	287	102.5
AC-2-SGRD4	114	C	6"	60	177	62	103.3
AC-2-SGRD5	107	A	6"	80	76	82	102.5

Completed By: Will Turnbough on

Heating Temperatures (F)

	Return Air		Outside Air		Entering Air Temp		Leaving Air Temp	
	DB Temp	WB Temp	DB Temp	WB Temp	DB Temp	WB Temp	DB Temp	WB Temp
RTU-1	71.5	51	33.5	26.9	68.6	49.1	97.4	63.7
RTU-2	70.8	50.7	33.5	26.9	63.5	46.0	96.5	63.3
RTU-3	68.5	51.4	33.5	26.9	61.8	46.7	113.8	70.4
RTU-4	69.2	50.2	33.5	26.9	61.6	45.2	97.6	63.5
RTU-5	74	52.6	33.5	26.9	64.5	46.5	97.5	63.4
AC-2	69.8	50.8	33.5	26.9	67.8	49.5	123.6	74.6

Note: Too cold to test cooling temperatures.

National TAB

Project: Gladstone Fire Station

System/Unit: Energy Recovery Unit



Comfort. Under control.

Asset: ERV1

AREA:117

Unit Data		
	Design	Actual
MFG	COOK	COOK
Model Num	ERV-1500	ERV-1500V
Serial Num	-	299SJ74888-00/0003101
Num Exh-Filters 1	-	1
Exh-Filter Size 1	-	20X24X2
Num Exh-Filters 2	-	1
Exh-Filter Size 2	-	12X24X2
Num OA-Filters 1	-	1/1
OA-Supply Size 1	-	20X24X2/12X24X2

Exhaust Fan Motor Data		
	Design	Actual
Motor MFG	-	MARATHON
Frame	-	56
Horsepower	0.33	1/3
Motor Rpm	-	1725
Phase	3	3
Voltage (rated)	208	208
Amperage (rated)	-	1.85
Service Factor	-	1.25

Exhaust Fan Drive Data		
	Design	Actual
Motor Sheave Size	-	3.25"
Motor Bore Size	-	5/8"
Fan Sheave Size	-	5"
Fan Sheave Bore	-	11/16"
Belt CL Distance	-	13.75"
Num of Belts	-	1
Belt Size	-	A36

OA Fan Motor Data		
	Design	Actual
Motor MFG	-	MARATHON
Frame	-	56
Horsepower	0.25	1/3
Motor Rpm	-	1725
Phase	3	3
Voltage (rated)	208	208
Amperage (rated)	-	1.85
Service Factor	-	1.25

Exhaust Fan Test Data		
	Design	Actual
Exh-ERU CFM	785	614
Exh-ERU RPM	-	948
Exh-ERU System SetPt	-	NA
RL Voltage	-	208 AVG
RL Amperage	-	1.9 AVG

Exhaust Fan Performance Data		
	Design	Actual
Exh-ERU Wheel Delta SP	-	0.48" (WHEEL + FILTERS)

OA Fan Test Data		
	Design	Actual
OA-ERU CFM	870	927
OA-ERU RPM	-	936
Motor Frequency	-	NA
RL Voltage	-	209 AVG
RL Amperage	-	2.0 AVG

OA Fan Performance Data		
	Design	Actual
OA-ERU Wheel Delta SP	-	0.43" (WHEEL + FILTER)

OA Fan Drive Data

	Design	Actual
Motor Sheave Size	-	3.25"
Motor Bore Size	-	5/8"
Fan Sheave Size	-	5"
Fan Sheave Bore	-	11/16"
Belt CL Distance	-	12.5"
Num of Belts	-	1
Belt Size	-	A36

Completed By: Jacob Davidson

Notes: 1/25 RETURN TRIP NOTES: AIRFLOW INITIALLY MEASURED AT GRILLES AS 398 CFM. BACKDRAFT DAMPER INSIDE THE ERV WAS NOT FULLY OPENING. PROPPED OPEN AND AIRFLOW INCREASED TO 486 CFM. UNABLE TO ACCESS MAIN DROP ABOVE CEILING FOR TRAVERSE. AIRFLOW MEASURED AT ROOF AS 614 CFM FOR REFERENCE BUT AIR WAS TURBULENT AND READING MAY NOT BE 100% RELIABLE.

National TAB

Project: Gladstone Fire Station

Energy Recovery Unit



Comfort. Under control.

Diffuser Ret/Exh (GRD)

ERV1/117

Asset							
Asset Name	Type	Size	DESIGN CFM	AK	CFM(1)	CFM(2)	FINAL CFM
EGRD1	F	10"X10"	245	1	139	173	209
EGRD2	F	6"X6"	100	1	27	59	72
EGRD3	F	6"X6"	100	1	28	40	49
EGRD4	F	6"X6"	100	1	21	31	36
EGRD5	F	6"X6"	100	1	26	40	49
EGRD6	F	6"X6"	75	1	28	20	29
EGRD7	F	6"X6"	65	1	25	35	42

Completed By: Michael Gabbert on

National TAB

Project: Gladstone Fire Station

System: ERV Exhaust

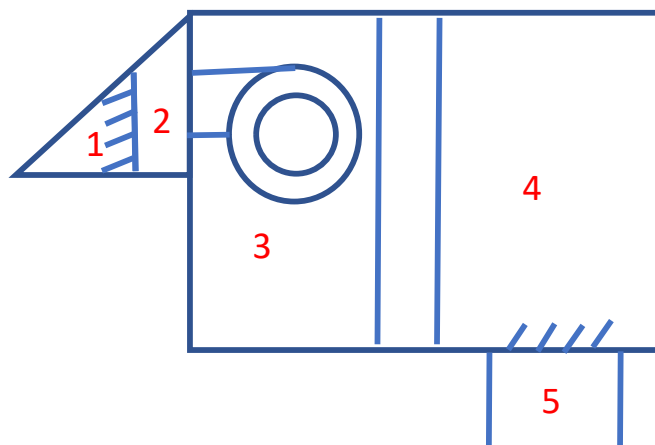

Pressure measurements:

- 1 0.00" wc
- 2 +0.13" wc
- 3 -0.59" wc
- 4 -0.14" wc
- 5 -0.11" wc (Note: taken with the back draft damper propped open)

National TAB

Project: Gladstone Fire Station
System/Unit: FAN - Exhaust



Comfort. Under control.

Asset: EF-1

AREA:147

Unit Data		
	Design	Actual
MFG	NA	COOK
Model Num	DD	70ACWH70W17DEC
Serial Num	-	299SJ74888-00/0000701
Type	CENT WALL	CENT WALL

Test Data		
	Design	Actual
CFM	155	142
RL Voltage	-	NOT SAFE
RL Amperage	-	NOT SAFE
Total ESP	0.25"	UTO

Motor Data		
	Design	Actual
Motor MFG	-	COOK
Frame	-	NL
Horsepower	33W	1/6
Motor Rpm	1725	1725
Phase	1	1
Voltage (rated)	120	120
Amperage (rated)	-	2.36
Service Factor	-	NL

Completed By: Jacob Davidson

Notes:

National TAB

Project: Gladstone Fire Station
System/Unit: FAN - Exhaust



Comfort. Under control.

Asset: EF-2

AREA:147

Unit Data		
	Design	Actual
MFG	NA	COOK
Model Num	DD	150 ACW 150W13D
Serial Num	-	299SJ74888- 00/0001901
Type	CENT WALL	CENT WALL

Test Data		
	Design	Actual
CFM	2150	2300
RL Voltage	-	NOT SAFE
RL Amperage	-	NOT SAFE
Total ESP	0.25"	UTO

Motor Data		
	Design	Actual
Motor MFG	-	GENTEQ
Frame	-	NL
Horsepower	0.33	3/4
Motor Rpm	1300	1300
Phase	1	1
Voltage (rated)	120	115
Amperage (rated)	-	9.0
Service Factor	-	NL

Completed By: Jacob Davidson

Notes:

National TAB

Project: Gladstone Fire Station
System/Unit: FAN - Exhaust



Comfort. Under control.

Asset: EF-3

AREA:120

Unit Data		
	Design	Actual
MFG	NA	COOK
Model Num	CEILING	GC-146 SONEBUSTER
Serial Num	-	NL

Test Data		
	Design	Actual
CFM	75	98

Motor Data		
	Design	Actual
Motor MFG	-	QUEACE
Horsepower	34W	15W
Motor Rpm	900	900
Phase	1	1
Voltage (rated)	120	120
Amperage (rated)	-	0.40

Completed By: Jacob Davidson

Notes:

National TAB

Project: Gladstone Fire Station
System/Unit: FAN - Exhaust



Comfort. Under control.

Asset: EF-A-1

AREA:105

Unit Data		
	Design	Actual
MFG	NA	COOK
Model Num	NA	GC-146 SONEBUSTER
Serial Num	-	NL

Test Data		
	Design	Actual
CFM	75	86

Motor Data		
	Design	Actual
Motor MFG	-	QUEACE
Horsepower	34W	15W
Motor Rpm	900	1550
Phase	1	1
Voltage (rated)	120	115
Amperage (rated)	-	0.40

Completed By: Jacob Davidson

Notes: 1/25 - RETURN TRIP NOTE: AIRFLOW REMEASURED AS 86 CFM.

National TAB

Project: Gladstone Fire Station
System/Unit: FAN - Exhaust



Comfort. Under control.

Asset: EF-A-2

AREA:104

Unit Data		
	Design	Actual
MFG	COOK	COOK
Model Num	GC-146	GC-146 SONEBUSTER
Serial Num	-	NL

Test Data		
	Design	Actual
CFM	75	83

Motor Data		
	Design	Actual
Motor MFG	-	QUEACE
Horsepower	34W	15W
Motor Rpm	900	1550
Phase	1	1
Voltage (rated)	120	115
Amperage (rated)	-	0.40

Completed By: Jacob Davidson

Notes: 1/25 - RETURN TRIP NOTE: AIRFLOW REMEASURED AS 83 CFM.

National TAB

Project: Gladstone Fire Station
System/Unit: FAN - Exhaust



Comfort. Under control.

Asset: EF-A-3

AREA:114

Unit Data		
	Design	Actual
MFG	COOK	COOK
Model Num	GC-146	GC-146 SONEBUSTER
Serial Num	-	NL

Test Data		
	Design	Actual
CFM	75	93

Motor Data		
	Design	Actual
Motor MFG	-	QUEACE
Horsepower	34W	15W
Motor Rpm	900	1550
Phase	1	1
Voltage (rated)	120	115
Amperage (rated)	-	0.40

Completed By: Jacob Davidson

Notes:

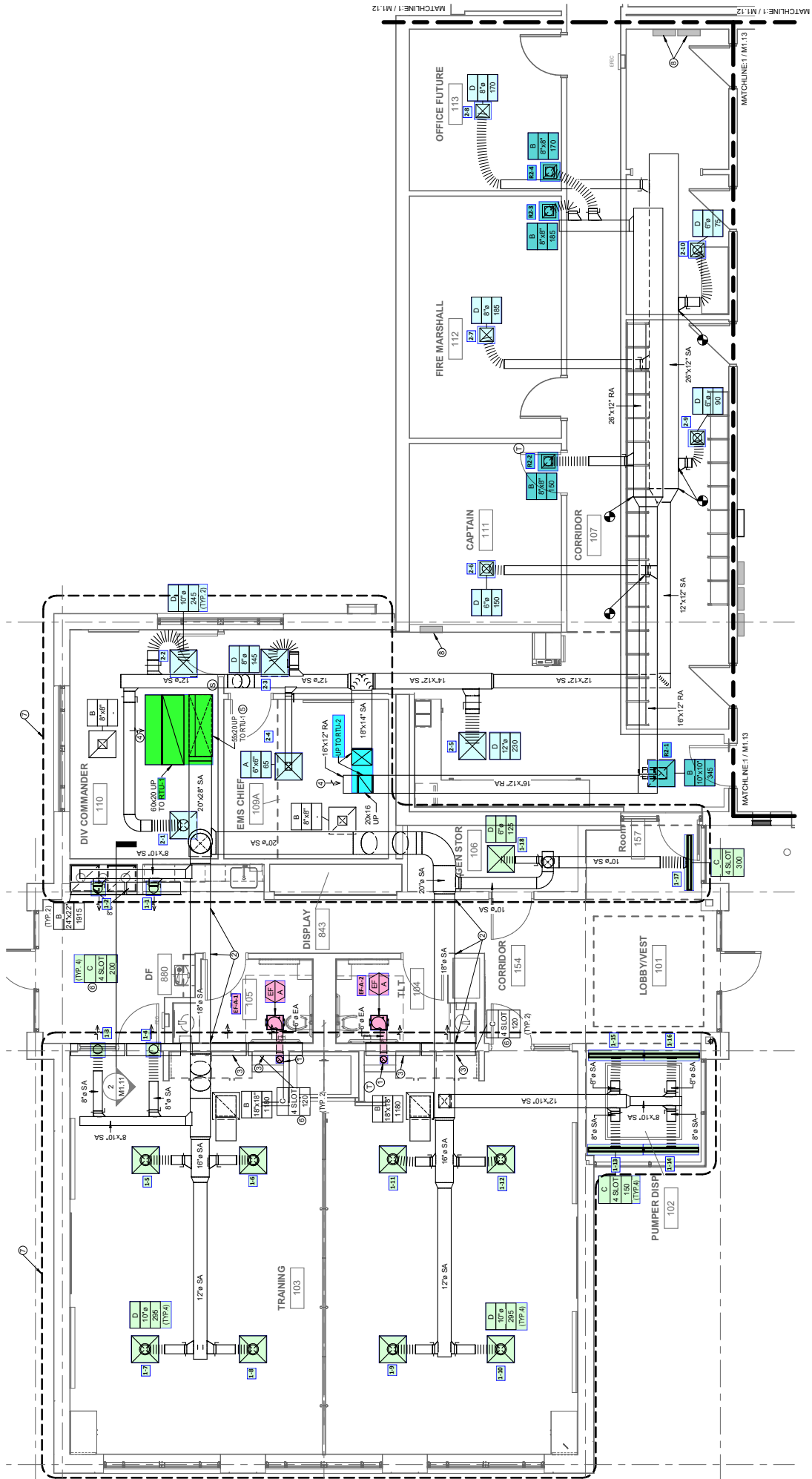



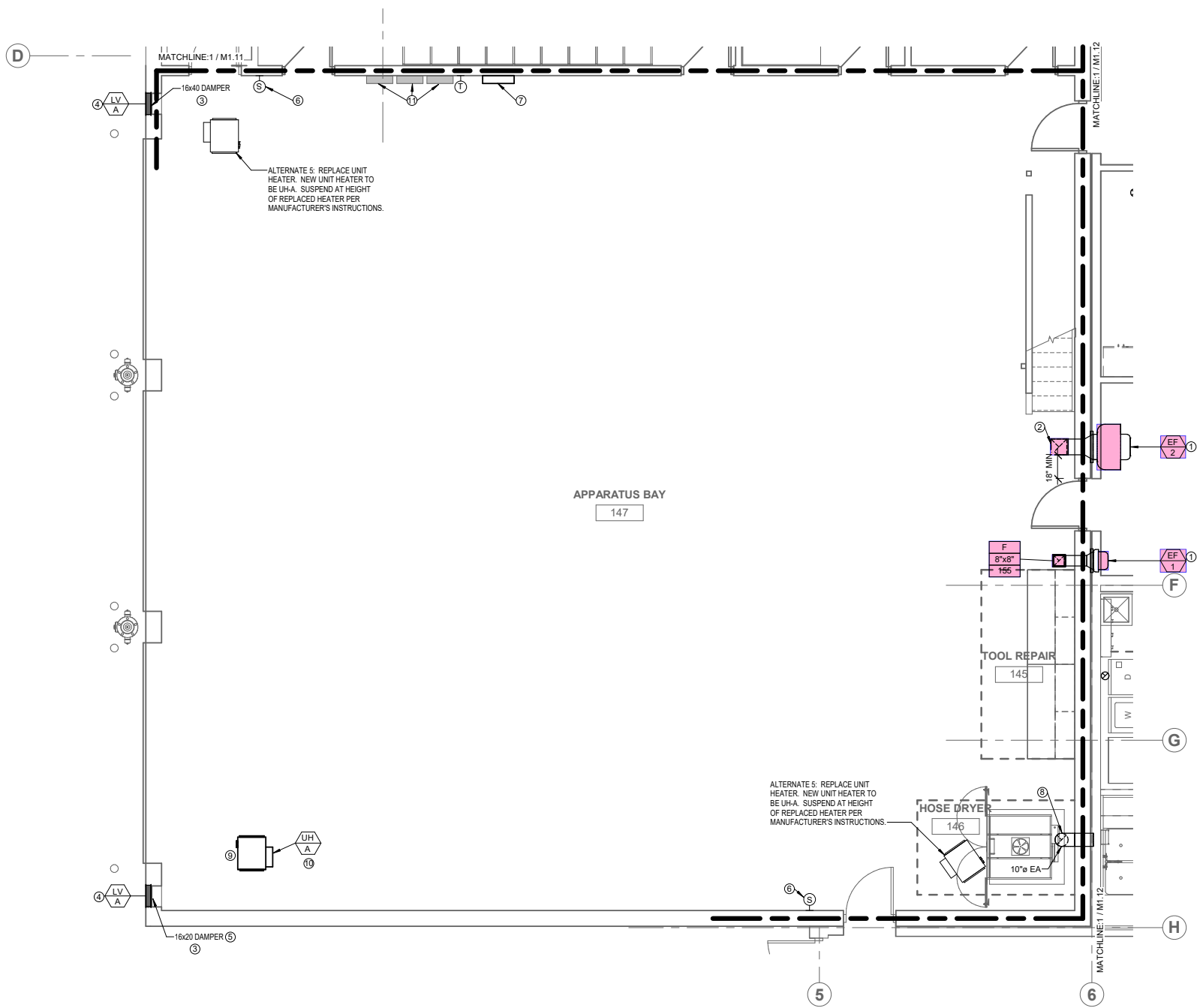



National TAB

Testing, Adjusting, and Balancing Equipment



Function		Range	Minimum Accuracy	Instrument Information	Calibration Date	Date Due
AIR	AIR PRESSURE	0 in wg to 10 in wg	2% +/- 0.001 in wg	TSI EBT731 EBT732117009	8/12/2022	8/12/2023
	AIR VELOCITY INSTRUMENT	50 fpm to 3900 fpm	+/- 5 % +/- 7 fpm	Evergreen Telemetry CH-15D 1600185	5/20/2022	5/20/2023
	DIRECT HOOD READING	100 cfm to 2000 cfm	+/- 5 % +/- 7 cfm	Evergreen Telemetry CH-15D 1600185	5/20/2022	5/20/2023
TEMPERATURE	AIR METER	-20 F to 240 F	+/- .5 % 2 F	Cooper SRH77A S/N 100516003	8/12/2022	8/12/2023
	AIR PROBE	-20 F to 240 F	+/- .5 % 2 F	Cooper SRH77A S/N 100516003	8/12/2022	8/12/2023
	IMMERSION METER	-20 F to 240 F	+/- .5 % 2 F	Cooper SRH77A S/N 100516003	8/12/2022	8/12/2023
	IMMERSION PROBE	-20 F to 240 F	+/- .5 % 2 F	Cooper SRH77A S/N 100516003	8/12/2022	8/12/2023
	CONTACT METER	-20 F to 240 F	+/- .5 % 2 F	Cooper SRH77A S/N 100516003	8/12/2022	8/12/2023
	CONTACT PROBE	-20 F to 240 F	+/- .5 % 2 F	Cooper SRH77A S/N 100516003	8/12/2022	8/12/2023
HUMIDITY	HUMIDITY PROBE	10 % RH to 90 % RH	3% of reading	Cooper SRH77A S/N 100516003	8/12/2022	8/12/2023
ELECTRICAL	VOLTAGE MEASUREMENT	0 VAC to 600 VAC	2 % reading +/- 5 digits	Fluke 323 S/N 35491023WS	8/11/2022	8/11/2023
	AMPERAGE MEASUREMENT	0 Amperes to 100 Amperes	2 % reading +/- 5 digits	Fluke 323 S/N 35491023WS	8/11/2022	8/11/2023
ROTATION	ROTATION MEASUREMENT	60 rpm to 5000 rpm	2 % reading 2 rpm	Shimpo DT 207Lp S/N D1690029R	8/11/2022	8/11/2023
HYDRONIC	PRESSURE MEASUREMENT	-30 in Hg to 200 psi	±2% of reading +/- 1 psi	Hydronic Manometer - Dwyer 490W-6-HKIT S/N: 359515093207912	8/12/2022	8/12/2023
	DIFFERENTIAL PRESSURE MEASUREMENT	0 psi - 80 psi	±2% of reading +/- 1 psi	Hydronic Manometer - Dwyer 490W-6-HKIT S/N: 359515093207912	8/12/2022	8/12/2023

NEBB Fundamental Formulas

NEBB ABBREVIATIONS	
A = Area (ft ²) IP, (m ²) SI	M = Mass (lb) IP, (kg) SI
ACH = Air Changes per Hour	ma = Mixed Air
A _k = Effective Area	m = meter (metre)
AV = Average	m ³ /s = Volumetric Flow: Cubic Meters Per Second
BHP = Brake Horsepower (IP) HP	NLA = No Load Amperage
BP = Brake Power (SI) kW	NPSHA = Net Positive Suction Head Available
Btu = British Thermal Unit	oa = Outside Air
Btu/h = Btuh = BTUH = BTU/Hour	% _{oa} = % of Outside Air
ϕ = Center Distance (used in belt formula)	Ω = Ohm
°C = Degrees Celsius, °C	P = Pressure
C = Friction Loss Coefficient (For Duct Fittings)	P _a = Atmospheric Pressure
CCF = 100 Cubic Feet	P _{ab} = Absolute Pressure (Atmospheric Pressure + Gauge Pressure)
CFM = Volumetric Flow: Cubic Feet Per Minute	Pa = Pascals, Pressure SI
C _p = Specific Heat	π = 3.14
C _v = Flow Constant (IP)	PD = Sheave Pitch Diameter
ρ = Density (lb/ft ³) IP, (kg/m ³) SI	P _ϕ = Pressure at Pump Centerline
d = Diameter (in.) IP, (mm) SI	ppm = parts per million
Δ = Difference or Change (Final - Initial)	psi = Pounds Per Square Inch
d _{imp} = Impeller Diameter	psia = Pounds Per Square Inch Absolute
E = Volts	psig = Pounds Per Square Inch Gauge
Eff = Efficiency	P _{vp} = Absolute Vapor Pressure
EP = Pump Efficiency	Q (flow) = Volumetric Fluid Flow Rate: (i.e. CFM, GPM, m ³ /s, l/s, etc.)
°F = Degrees Fahrenheit, °F	Q (heat) = Heat Flow Rate (BTU/Hour) IP, (W or kW) SI
f = Friction Factor	°R = °Rankin = Degrees Rankin, °R
FLA = Full Load Amps	r = Radius (in) IP, (mm) SI
fpm = Feet per Minute (fpm)	% _{ra} = % of Return Air
ft = Foot	R = Resistance
g = Acceleration of Gravity	ra = Return Air
gal = Gallons	rad = Radians
GPM = Gallons Per Minute (GPM)	RH = Relative Humidity
h = Enthalpy (BTU/lb dry air) IP, (kJ/kg dry air) SI	RPM = Revolutions Per Minute
H = Head (in wc, ft wc, psi) IP, (Pa, kPa) SI	R _{value} = Thermal Resistance
Hg = Mercury	s = second
h _{ma} = Mixed Air Enthalpy	SHR = Sensible Heat Ratio
h _{oa} = Outside Air Enthalpy	SME = Sash Movement Effect Performance Rating (SME-XX yyy)
HP = Horsepower	SP = Static Pressure
hr = Hour	Sp Gr = Specific Gravity (for water use 1.00)
h _{ra} = Return Air Enthalpy	T = Temperature
HT = Height (in) IP, (mm) SI	T _a = Absolute Temperature (460° + T) or °R
I = Amps	T _{ma} = Mixed Air Temperature
J = Joules	T _{oa} = Outside Air Temperature
K = Kelvin, K	TP = Total Pressure
K _v = Flow constant (SI)	T _{ra} = Return Air Temperature
kg = Kilogram	TS = Tip Speed (fpm) IP, (m/s) SI
kJ = Kilojoule	U = Heat Transfer Coefficient
kPa = Kilopascal	μ = viscosity, dynamic
kW = Kilowatt = 1000 Watts	V = Velocity
l = Liter (Litre)	VP = Velocity Pressure
l/s = Volumetric Flow: Liters Per Second	W = Watt
lb = Pounds	WD = Width (in) IP, (mm) SI
lm = Lumens	wg = wc = water gauge = water column
ln = natural log	WHP = Water Horsepower (IP)
LG = Length (in) IP, (mm) SI	WP = Water Power (SI)
lx = Lux	ω = Humidity Ratio (lb or grains of water/lb of dry air) (g H ₂ O/kg dry air)