



Submittal #233113-1.0 - Variable Air Volume Terminal Units (VAV) 233113 - Air Distribution Design

Revision	0	Submittal Manager	Michael Huntsman (Suffolk Construction Company, Inc.)
Status	Open	Date Created	Sep 11, 2024
		Spec Section	233113 - Air Distribution Design
Responsible Contractor	Gutridge - Mechanical		
		Submit By	
Final Due Date	Sep 25, 2024	Lead Time	
		Type	Product Data
Approvers	Delaine Novak (Swanson Rink), Keeley Randell (Swanson Rink)		
Ball in Court	Delaine Novak (Swanson Rink), Keeley Randell (Swanson Rink)		
Distribution	Brandon Jones (Suffolk Construction Company, Inc.), Delaine Novak (Swanson Rink), James Leadingham (AWS Infrastructure), Kevin Bourgo (Suffolk Construction Company, Inc.), Leon Roberts (Suffolk Construction Company, Inc.), Lisa Kore (Swanson Rink), Michael Huntsman (Suffolk Construction Company, Inc.), Michael James (Suffolk Construction Company, Inc.), Michael Steinemann (DLB Associates), Rodney Brockelman (Swanson Rink), Thana Taliep (Gensler)		
Description			
Variation from Drawings/Specifications		Procurement Owner	GC
Responsible Discipline(s)	Mechanical	FBN Build ID(s)	LCK062SHLP01.001
Design Type		PAC FBN	
PAC Region(s)		Comments for Reviewers	
PAC Category(s)		PAC Submittals Only - Previous Status	
Additional Reporting Requirements for Embodied Carbon	<ul style="list-style-type: none"> • AMER - For concrete, steel, deck, joists, rebar, roofing, drywall, refer to the Carbon Quantity & EPD Reporting (AMER) SOP • EMEA/APJC - For concrete, refer to the Carbon Quantity & EPD Reporting (EMEA & APAC) SOP 		

Submittal Workflow

Name	Sent Date	Due Date	Returned Date	Response	Attachments
General Information Attachments					SHLP01-233113-01.0 Variable Air Volume Terminal Units (VAV).pdf
Delaine Novak	Sep 11, 2024	Sep 25, 2024		Pending	
Keeley Randell	Sep 11, 2024	Sep 25, 2024		Pending	

 SUBMITTAL/SHOP DRAWING DISCIPLINE REVIEW MATRIX					
	NXT	MCN	R&R	REJ	NR
MECHANICAL		X			
PLUMBING/FIRE PROT.					X
ELECTRICAL		X			
LIGHTING					X
FIRE ALARM					X
TELECOM					X
SECURITY					X
AUDIO/VIDEO					X
AVIATION					X
CONTROLS					X

NXT = NO EXCEPTIONS TAKEN
 MCN = MAKE CORRECTIONS NOTED
 R&R = REVISE AND RESUBMIT
 REJ = REJECTED
 NR = NOT REVIEWED

 SUBMITTAL/SHOP DRAWING REVIEW	
<input type="checkbox"/> NO EXCEPTIONS TAKEN	<input type="checkbox"/> ADDRESS COMMENTS NOTED
<input type="checkbox"/> REJECTED	<input type="checkbox"/> REVISE AND RESUBMIT
<input type="checkbox"/> NOT REVIEWED	<input checked="" type="checkbox"/> SEE SEPARATE DISCIPLINE REVIEW MATRIX
<p>Corrections or comments made on the shop drawings during this review do not relieve the contractor from compliance with requirements of the drawings and specifications. This check is only for review of general conformance with the design concept of the project and general compliance with the information given in the contract documents. The contractor is responsible for confirming and correlating all quantities and dimensions; selecting fabrication processes and techniques of construction; coordinating his work with that of all other trades; and performing his work in a safe and satisfactory manner. This submittal/shop drawing is in electronic format. As such, Swanson Rink is not liable for alterations to the content of this electronic document after it has been forwarded to other parties.</p>	
Reviewed By: <u>Brendan Phipps</u>	Date: <u>2024-09-17</u>

VAV 1-10 heating airflow = 410 cfm
 VAV 1-12 heating airflow = 115 cfm
 VAV 1-14 heating airflow = 205 cfm
 BP, SRI - 9/17/2024

9/19/2024
 VAV 1-13 FLA and MCA values are inconsistent with mechanical drawing wattage and electrical drawing. Match with values indicated on sheet 8. Thank you.
 Pavel Dzyachenka, EIT
 Swanson Rink

Suffolk
65 Allerton St.
Boston, MA 02119
617-445-3500



THE REVIEW OF THIS SUBMITTAL BY SUFFOLK DOES NOT RELIEVE THE SUBCONTRACTOR OR SUPPLIER OF HIS RESPONSIBILITY FOR THE QUANTITY, OR ACCURACY OF THIS WORK HEREIN REPRESENTED, OR ANY DEVIATION FROM THE PLANS, SPECIFICATIONS, AND CONTRACT.

Proj #

<input type="checkbox"/>	<input type="checkbox"/>	<input type="checkbox"/>	<input type="checkbox"/>
REVIEWED	REVIEWED AS NOTED	REVISE & RESUBMIT	REJECTED

BY

DATE

SUBM #

COMMENTS



Submittal Transmittal

88 S. Second Street
Newark, OH 43055
Phone: (740) 349-9411
Fax: (740) 345-6020

PROJECT NAME: Suffolk - LCK062
PROJECT ADDRESS: 2890 Beech Rd NW
New Albany, OH 43031

DATE: 9/9/2024

CONTRACT ID: 24087

MECHANICAL CONTRACTOR:

KE Gutridge
88 South 2ND Street
Newark, Ohio 43055

ENGINEER:

Swanson Rink, Inc.
1120 Lincoln Street #1200
Denver, CO 80209

GENERAL CONTRACTOR:

Suffolk Construction Company
65 Allerton Street
Boston, MA 02119

SPECIFICATION NAME & NUMBER:

233113-2.14

PRODUCT DESCRIPTION:

Variable Air Volume Terminal Units (VAV)

PRODUCT MANUFACTURER:

Trane

PRODUCT SUPPLIER:

Trane Technologies

RETURN BY: 9/16/2024

I CERTIFY THAT GUTRIDGE HAS CHECKED THIS SUBMITTAL FOR CONFORMANCE WITH PLANS AND SPECIFICATIONS.

SIGNED: _____

***** PLEASE DO NOT MARK ABOVE THIS AREA. SPACE BELOW PROVIDED FOR NOTES AND STAMPS *****



National Account VAV Submittal

Prepared For:
All Bidders

Date: August 23, 2024

Job Name:
Web Services LCK062 Bldg B Shell

Trane U.S. Inc. is pleased to provide the following submittal for your review and approval.

Product Summary

Qty Product

33 Variable Air Volume Single Duct Terminal Units

Jeffrey K Jenson/ ND
Trane U.S. Inc.
2333 158th Court NE
Bellevue, WA 98008
Office Phone: (425) 643-4310

The attached information describes the equipment we propose to furnish for this project and is submitted for your approval.

Submittal acceptance and return is a critical step, so please ensure submittals are returned with approval to release to production within 14 days of submittal date.

Product performance and submittal data is valid for a period of 6 months from the date of submittal generation. If six months or more has elapsed between submittal generation and equipment release, the product performance and submittal data will need to be verified. It is the customer's responsibility to obtain such verification.

Tag Data – Variable Air Volume Units (Qty: 33)

Item	Tag(s)	Qty	Description
I1	VAV 1-1 through VAV 2-9	33	Variable Air Volume Units

All Units

Single duct VAV
Staged electrical heaters with 24V magnetic contractor where specified
½" matte faced insulation
Actuator
BACnet controller
Disconnect ✓
Control transformer
Zone sensor (Field Installed)
1 Year parts warranty

Performance Data - Variable Air Volume Single Duct Terminal Units

Tags	VAV 1-1	VAV 1-2	VAV 1-3	VAV 1-4	VAV 1-5	VAV 1-6
UCM/UC400 address	0	0	0	0	0	0
Design cooling airflow (cfm)	180	260	265	460	745	300
Min cooling airflow (cfm)	95	260	100	225	710	175
Valve heating airflow (cfm)	95	260	100	225	710	175
Cooling inlet diameter	4"	5"	5"	6"	10"	5"
Cooling inlet velocity (ft/min)	1490	1907	2090	2343	1733	2200
APD @ cooling airflow (in H2O)	0.010	0.020	0.020	0.180	0.030	0.020
Elevation (ft)	0.00	0.00	0.00	0.00	0.00	0.00
Full load amps (A)	3.61	9.03	3.61	9.03	8.42	7.22
Min circuit ampacity (A)	4.51	11.28	4.51	11.28	10.52	9.03
Max fuse size (A)	15.00	15.00	15.00	15.00	15.00	15.00
Operating weight (lb)	81.7	81.7	81.7	81.7	101.0	81.7
Run acoustics?	No	No	No	No	No	No
Hot water valves?	None	None	None	None	None	None
Main Unit Weight (lb)	21.0	21.0	21.0	21.0	30.0	21.0
Plenum Weight (lb)	0.0	0.0	0.0	0.0	0.0	0.0
Attenuator Weight (lb)	14.7	14.7	14.7	14.7	20.0	14.7
FIPP Weight (lb)	0.0	0.0	0.0	0.0	0.0	0.0
Dual-Wall Weight (lb)	0.0	0.0	0.0	0.0	0.0	0.0
Weight 6 (lb)	0.0	0.0	0.0	0.0	0.0	0.0
Coil Weight (lb)	0.0	0.0	0.0	0.0	0.0	0.0
EH Weight (lb)	46.0	46.0	46.0	46.0	51.0	46.0
Replication Run	286	286	286	286	286	286
Trane Select Assist Version Number	286	286	286	286	286	286
Coil heating capacity (MBh)	3.42	8.54	3.42	8.54	23.91	6.83
Room heat loss (MBh)	2.08	4.87	2.00	5.36	13.89	4.36
Room heating setpoint (F)	68.00	68.00	68.00	68.00	68.00	68.00
Primary EDB (F)	55.00	55.00	55.00	55.00	55.00	55.00
Unit LAT (F)	88.13	85.26	86.47	89.97	86.03	90.97
Electric heater kW (kW)	1.00	2.50	1.00	2.50	7.00	2.00

VAV 1-10 heating airflow = 410 cfm

VAV 1-12 heating airflow = 115 cfm

BP, SRI - 9/17/2024

Tags	V 1-7	VAV 1-8	VAV 1-9	VAV 1-10	VAV 1-11	VAV 1-12
UCM/UC400 address	0	0	0	0	0	0
Design cooling airflow (cfm)	265	465	300	1100	420	210
Min cooling airflow (cfm)	155	210	410	410	110	115
Valve heating airflow (cfm)	155	210	410	410	124	115
Cooling inlet diameter	4"	6"	10"	10"	5"	4"
Cooling inlet velocity (ft/min)	1943	2215	1650	2017	2139	2406
APD @ cooling airflow (in H2O)	0.020	0.170	0.020	0.030	0.150	0.020
Elevation (ft)	0.00	0.00	0.00	0.00	0.00	0.00
Full load amps (A)	5.42	7.22	4.81	4.81	5.42	3.61
Min circuit ampacity (A)	6.77	9.03	6.01	6.01	6.77	4.51
Max fuse size (A)	15.00	15.00	15.00	15.00	15.00	15.00
Operating weight (lb)	81.7	81.7	101.0	101.0	81.7	81.7
Run acoustics?	No	No	No	No	No	No
Hot water valves?	None	None	None	None	None	None
Main Unit Weight (lb)	21.0	21.0	30.0	30.0	21.0	21.0
Plenum Weight (lb)	0.0	0.0	0.0	0.0	0.0	0.0
Attenuator Weight (lb)	14.7	14.7	20.0	20.0	14.7	14.7
FIPP Weight (lb)	0.0	0.0	0.0	0.0	0.0	0.0
Dual-Wall Weight (lb)	0.0	0.0	0.0	0.0	0.0	0.0
Weight 6 (lb)	0.0	0.0	0.0	0.0	0.0	0.0
Coil Weight (lb)	0.0	0.0	0.0	0.0	0.0	0.0
EH Weight (lb)	46.0	46.0	51.0	51.0	46.0	46.0
Replication Run	286	286	286	286	286	286

Tags	VAV 1-7	VAV 1-8	VAV 1-9	VAV 1-10	VAV 1-11	VAV 1-12
Trane Select Assist Version Number	286	286	286	286	286	286
Coil heating capacity (MBh)	5.12	6.83	13.66	13.66	5.12	3.42
Room heat loss (MBh)	2.94	3.87	7.88	9.57	3.37	2.24
Room heating setpoint (F)	68.00	68.00	68.00	68.00	68.00	68.00
Primary EDB (F)	55.00	55.00	55.00	55.00	55.00	55.00
Unit LAT (F)	85.46	84.98	85.71	98.41	93.07	92.92
Electric heater kW (kW)	1.50	2.00	4.00	4.00	1.50	1.00

Tags	VAV 1-13	VAV 1-14	VAV 1-15	VAV 1-16	VAV 1-17	VAV 1-18
UCM/UC400 address	0	0	0	0	0	0
Design cooling airflow (cfm)	475	265	615	800	360	265
Min cooling airflow (cfm)	260	265	555	510	335	190
Valve heating airflow (cfm)	260	205 265	365	510	365	190
Cooling inlet diameter	8"	5"	8"	8"	6"	5"
Cooling inlet velocity (ft/min)	1361	1943	1762	1719	1833	1943
APD @ cooling airflow (in H2O)	0.030	0.020	0.050	0.050	0.110	0.020
Elevation (ft)	0.00	0.00	0.00	0.00	0.00	0.00
Full load amps (A)	3 - 9.03	7.22	6.62	6.01	4.21	7.22
Min circuit ampacity (A)	3.76 11.28	9.03	8.27	7.52	5.26	9.03
Max fuse size (A)	15.00	15.00	15.00	15.00	15.00	15.00
Operating weight (lb)	84.7	81.7	84.7	84.7	81.7	81.7
Run acoustics?	No	No	No	No	No	No
Hot water valves?	None	None	None	None	None	None
Main Unit Weight (lb)	22.0	21.0	22.0	22.0	21.0	21.0
Plenum Weight (lb)	0.0	0.0	0.0	0.0	0.0	0.0
Attenuator Weight (lb)	17.7	14.7	17.7	17.7	14.7	14.7
FIPP Weight (lb)	0.0	0.0	0.0	0.0	0.0	0.0
Dual-Wall Weight (lb)	0.0	0.0	0.0	0.0	0.0	0.0
Weight 6 (lb)	0.0	0.0	0.0	0.0	0.0	0.0
Coil Weight (lb)	0.0	0.0	0.0	0.0	0.0	0.0
EH Weight (lb)	45.0	46.0	45.0	45.0	46.0	46.0
Replication Run	286	286	286	286	286	286
Trane Select Assist Version Number	286	286	286	286	286	286
Coil heating capacity (MBh)	8.54	6.83	18.78	17.08	11.95	6.83
Room heat loss (MBh)	4.87	3.09	10.95	9.88	7.23	4.15
Room heating setpoint (F)	68.00	68.00	68.00	68.00	68.00	68.00
Primary EDB (F)	55.00	55.00	55.00	55.00	55.00	55.00
Unit LAT (F)	85.26	78.75	86.19	85.86	87.88	88.13
Electric heater kW (kW)	2.50	2.00	3.50	3.00	3.50	2.00

Tags	VAV 1-19	VAV 1-20	VAV 1-21	VAV 1-22	VAV 1-23	VAV 1-24
UCM/UC400 address	0	0	0	0	0	0
Design cooling airflow (cfm)	840	560	1260	525	260	950
Min cooling airflow (cfm)	780	560	495	525	110	950
Valve heating airflow (cfm)	780	560	495	525	124	950
Cooling inlet diameter	8"	8"	10"	6"	5"	10"
Cooling inlet velocity (ft/min)	2320	1604	2310	1504	1907	1742
APD @ cooling airflow (in H2O)	0.080	0.050	0.040	0.040	0.020	0.010
Elevation (ft)	0.00	0.00	0.00	0.00	0.00	0.00
Full load amps (A)	8.42	6.62	6.01	6.01	5.42	-
Min circuit ampacity (A)	10.52	8.27	7.52	7.52	6.77	-
Max fuse size (A)	15.00	15.00	15.00	15.00	15.00	-
Operating weight (lb)	84.7	84.7	101.0	84.7	81.7	50.0
Run acoustics?	No	No	No	No	No	No
Hot water valves?	None	None	None	None	None	None
Main Unit Weight (lb)	22.0	22.0	30.0	22.0	21.0	30.0

Tags	VAV 1-19	VAV 1-20	VAV 1-21	VAV 1-22	VAV 1-23	VAV 1-24
Plenum Weight (lb)	0.0	0.0	0.0	0.0	0.0	0.0
Attenuator Weight (lb)	17.7	17.7	20.0	17.7	14.7	20.0
FIPP Weight (lb)	0.0	0.0	0.0	0.0	0.0	0.0
Dual-Wall Weight (lb)	0.0	0.0	0.0	0.0	0.0	0.0
Weight 6 (lb)	0.0	0.0	0.0	0.0	0.0	0.0
Coil Weight (lb)	0.0	0.0	0.0	0.0	0.0	0.0
EH Weight (lb)	45.0	45.0	51.0	45.0	46.0	0.0
Replication Run	286	286	286	286	286	286
Trane Select Assist Version Number	286	286	286	286	286	286
Coil heating capacity (MBh)	23.91	18.78	17.08	17.08	5.12	-
Room heat loss (MBh)	12.90	10.88	10.09	9.67	3.37	-
Room heating setpoint (F)	68.00	68.00	68.00	68.00	68.00	68.00
Primary EDB (F)	55.00	55.00	55.00	55.00	55.00	55.00
Unit LAT (F)	83.25	85.91	86.79	84.98	93.07	55.00
Electric heater kW (kW)	7.00	5.50	5.00	5.00	1.50	0.00

Tags	VAV 2-1	VAV 2-2	VAV 2-3	VAV 2-4	VAV 2-5	VAV 2-6
UCM/UC400 address	0	0	0	0	0	0
Design cooling airflow (cfm)	570	1200	1200	875	1600	1200
Min cooling airflow (cfm)	440	660	655	315	1600	500
Valve heating airflow (cfm)	440	660	655	315	1600	500
Cooling inlet diameter	8"	10"	10"	8"	2"	10"
Cooling inlet velocity (ft/min)	1461	2200	2200	2507	2037	2200
APD @ cooling airflow (in H2O)	0.040	0.040	0.040	0.090	0.010	0.040
Elevation (ft)	0.00	0.00	0.00	0.00	0.00	0.00
Full load amps (A)	5.41	7.82	7.82	10.83	-	6.01
Min circuit ampacity (A)	6.77	9.77	9.77	13.54	-	7.52
Max fuse size (A)	15.00	15.00	15.00	15.00	-	15.00
Operating weight (lb)	84.7	101.0	101.0	84.7	59.7	101.0
Run acoustics?	No	No	No	No	No	No
Hot water valves?	None	None	None	None	None	None
Main Unit Weight (lb)	22.0	30.0	30.0	22.0	38.0	30.0
Plenum Weight (lb)	0.0	0.0	0.0	0.0	0.0	0.0
Attenuator Weight (lb)	17.7	20.0	20.0	17.7	21.7	20.0
FIPP Weight (lb)	0.0	0.0	0.0	0.0	0.0	0.0
Dual-Wall Weight (lb)	0.0	0.0	0.0	0.0	0.0	0.0
Weight 6 (lb)	0.0	0.0	0.0	0.0	0.0	0.0
Coil Weight (lb)	0.0	0.0	0.0	0.0	0.0	0.0
EH Weight (lb)	45.0	51.0	51.0	45.0	0.0	51.0
Replication Run	286	286	286	286	286	286
Trane Select Assist Version Number	286	286	286	286	286	286
Coil heating capacity (MBh)	15.37	22.20	22.20	10.25	-	17.08
Room heat loss (MBh)	9.16	12.89	12.96	5.80	-	10.02
Room heating setpoint (F)	68.00	68.00	68.00	68.00	68.00	68.00
Primary EDB (F)	55.00	55.00	55.00	55.00	55.00	55.00
Unit LAT (F)	87.19	86.00	86.23	84.98	55.00	86.47
Electric heater kW (kW)	4.50	6.50	6.50	3.00	0.00	5.00

Tags	VAV 2-7	VAV 2-8	VAV 2-9
UCM/UC400 address	0	0	0
Design cooling airflow (cfm)	385	1200	345
Min cooling airflow (cfm)	320	720	115
Valve heating airflow (cfm)	320	720	124
Cooling inlet diameter	6"	10"	6"
Cooling inlet velocity (ft/min)	1961	2365	1757
APD @ cooling airflow (in H2O)	0.130	0.040	0.110

Tags	VAV 2-7	VAV 2-8	VAV 2-9
Elevation (ft)	0.00	0.00	0.00
Full load amps (A)	✓4.21	✓8.42	✓5.42
Min circuit ampacity (A)	✓5.26	✓10.52	✓6.77
Max fuse size (A)	15.00	15.00	15.00
Operating weight (lb)	81.7	101.0	81.7
Run acoustics?	No	No	No
Hot water valves?	None	None	None
Main Unit Weight (lb)	21.0	30.0	21.0
Plenum Weight (lb)	0.0	0.0	0.0
Attenuator Weight (lb)	14.7	20.0	14.7
FIPP Weight (lb)	0.0	0.0	0.0
Dual-Wall Weight (lb)	0.0	0.0	0.0
Weight 6 (lb)	0.0	0.0	0.0
Coil Weight (lb)	0.0	0.0	0.0
EH Weight (lb)	46.0	51.0	46.0
Replication Run	286	286	286
Trane Select Assist Version Number	286	286	286
Coil heating capacity (MBh)	11.95	23.91	5.12
Room heat loss (MBh)	7.44	13.75	3.37
Room heating setpoint (F)	68.00	68.00	68.00
Primary EDB (F)	55.00	55.00	55.00
Unit LAT (F)	89.43	85.60	93.07
Electric heater kW (kW)	✓3.00	✓7.00	✓1.50

Mechanical Specifications - Variable Air Volume Single Duct Terminal Units

Item: A1 - A33 Qty: 33 Tag(s): VAV 1-1, VAV 1-2, VAV 1-3, VAV 1-4, VAV 1-5, VAV 1-6, VAV 1-7, VAV 1-8, VAV 1-9, VAV 1-10, VAV 1-11, VAV 1-12, VAV 1-13, VAV 1-14, VAV 1-15, VAV 1-16, VAV 1-17, VAV 1-18, VAV 1-19, VAV 1-20, VAV 1-21, VAV 1-22, VAV 1-23, VAV 1-24, VAV 2-1, VAV 2-2, VAV 2-3, VAV 2-4, VAV 2-5, VAV 2-6, VAV 2-7, VAV 2-8, VAV 2-9

1/2" Matte - Faced Insulation

The interior surface of the unit casing is acoustically and thermally lined with 1/2" 2.6 lb.cu. ft. [24.00 kg./cu. m.] composite density glass fiber high density facing. The insulation is UL listed and meets NFPA-90A and UL 181 standards. The insulation R-value is 2.2. All cut edges of insulation are completely encapsulated in metal to prevent erosion.

Air Valve Size - 04

Air Valve is 225.0 cfm 4" inlet.

Air Valve Size - 05

Air Valve is 350.0 cfm 5" inlet.

Air Valve Size - 06

Air Valve is 500.0 cfm 6" inlet.

Air Valve Size - 08

Air Valve is 900.0 cfm 8" inlet.

Air Valve Size - 10

Air Valve is 1400.0 cfm 10" inlet.

Air Valve Size - 12

Air Valve is 2000.0 cfm 12" inlet.

Air Valve Round

The air inlet connection is an 18 gauge galvanized steel cylinder sized to fit standard round duct. A multiple point, averaging flow sensing ring is provided with balancing taps for measuring within +/- 5% of unit cataloged airflow. An airflow versus pressure differential calibration chart is provided. The damper blade is constructed of a closed cell foam seal mechanically locked between two 22 gauge galvanized steel disks. The damper blade assembly is connected through a cast zinc stub axle and shaft supported by self lubricating bearings. The shaft is cast with a damper position indicator. The valve assembly includes a mechanical stop to prevent over stroking. At 4.0" w.g. air valve leakage does not exceed 1% of cataloged airflow.

✓✓ Power Disconnect Switch (for VCEF)

A factory provided interlocking door disconnect switch located on the electric heater control panel.

Slip & Drive Connection

A slip and drive connection has two straight flanges on the top and bottom, and two drive connections on the left and right sides. This is a standard option on all VAV single duct terminal units.

✓ Electric Heat Coil

Factory provided and mounted resistance open-coil type heater with airflow switch, a disc-type automatic pilot duty thermal primary cutoff, and manually resettable pilot-duty thermal secondary cutoff with associated backup contactor. Heater element material is type C nickel-chromium alloy. The heater terminal box is provided with 7/8" knockouts for customer power supply. Terminal connections are plated steel with ceramic insulators. Unit is Flippable for both Left and Right hand control access, except with mercury contactor option.

Toggle Disconnect Switch (for VCCF & VCWF)

A switch, installed in a unit mounted controls enclosure, which breaks both power legs within the control box.

Magnetic Contactor

An electric heater 24 volt contact for use with Direct Digital Control (D.D.C.) or Analog Electronic VAV Controls.

Electric Heat Transformer

A 50VA or 75VA class 2 transformer will be an integral component of the heater control panel dependent on unit load requirements to provide 24 VAC for controls.

✓ **Control Transformer**

The 50 VA transformer is factory mounted in a unit mounted controls enclosure with 7/8" knockouts to provide 24 VAC for controls.

✓ **D.D.C. Floating Point Actuator**

Trane 3 wire, (open, close, common) 26GA when 6-pos amp connector is used for Tracer UC210, VV550, or VAV UCM, otherwise 18GA wires are used. 3.4 VA, 1.7W, 24 VAC, 50/60 Hz. Quarter turn control actuator with linkage release button. Actuator has a constant drive rate independent of load, a rated torque of 35 in-lb, a 90-second drive time and is non-spring return. Travel is terminated by end stops at fully opened and closed positions. An integral magnetic clutch eliminates motor stall. An integral 3 screw terminal block is provided for field wiring. Operating temperature 32.0 F to 125.0 F.

Factory Mounted DTS (VCCF)

Factory Mounted internal to the Single Duct Terminal unit. The DTS is a 4" 10k ohm thermistor and is factory mounted into the Single Duct Terminal and is factory wired back to the Trane controls.

Dimensional Drawings - Variable Air Volume Single Duct Terminal Units

Item: A1, A12 Qty: 2 Tag(s): VAV 1-1, VAV 1-12

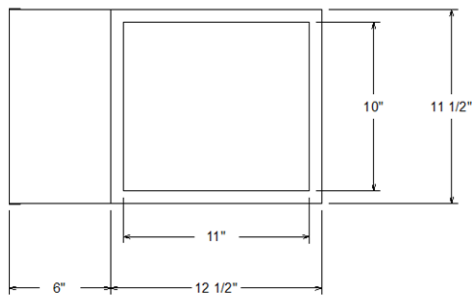
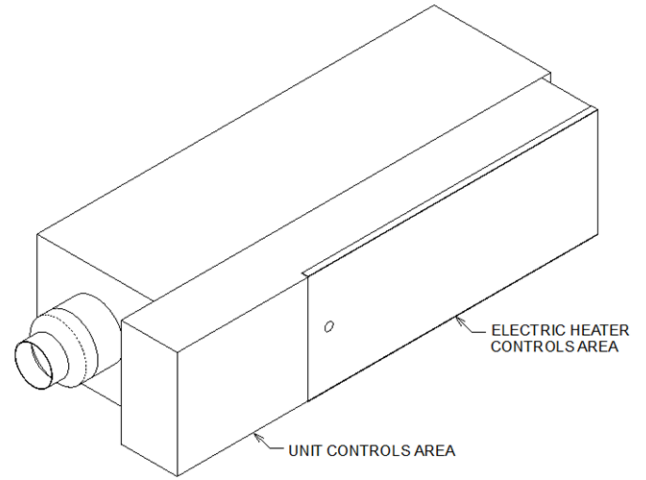
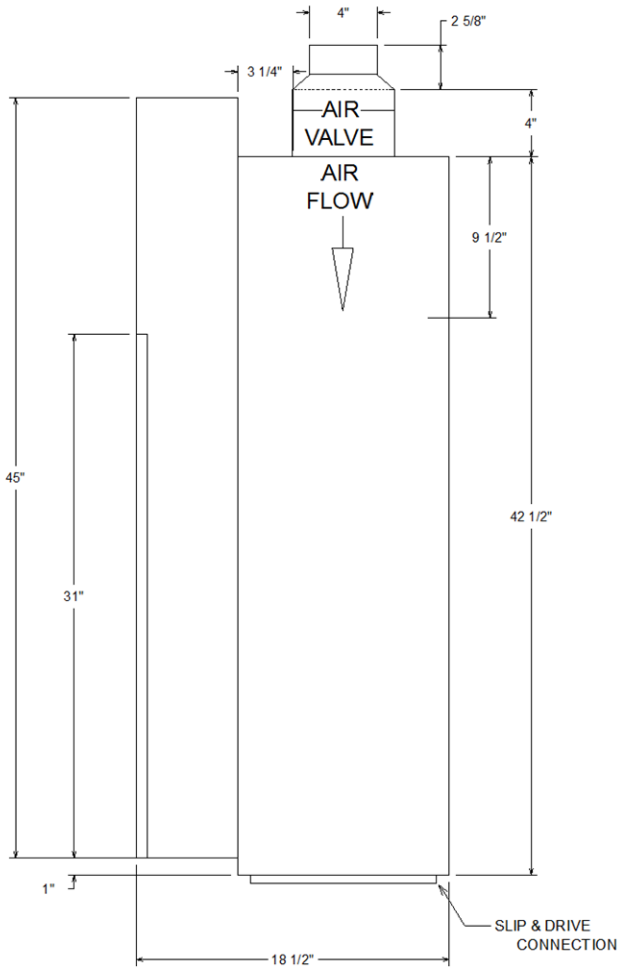

BACK VIEW

Approximate Dry Weight	81.7 lb
------------------------	---------

Weight reflected may vary 5 lbs(2.27kgs) based upon options selected.

Dimensional Drawings - Variable Air Volume Single Duct Terminal Units

Item: A2, A3, A6, A7, A14, A18, A23 Qty: 7 Tag(s): VAV 1-2, VAV 1-3, VAV 1-6, VAV 1-7, VAV 1-14, VAV 1-18, VAV 1-23

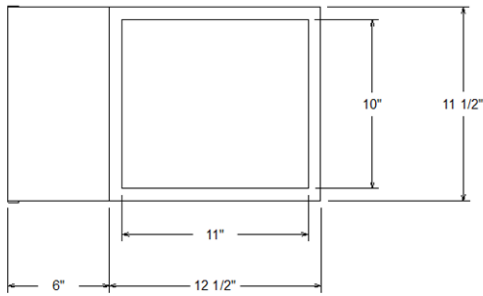
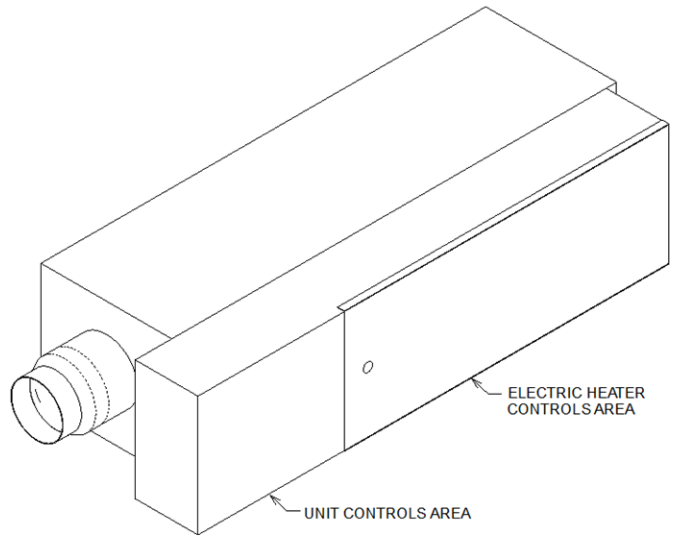
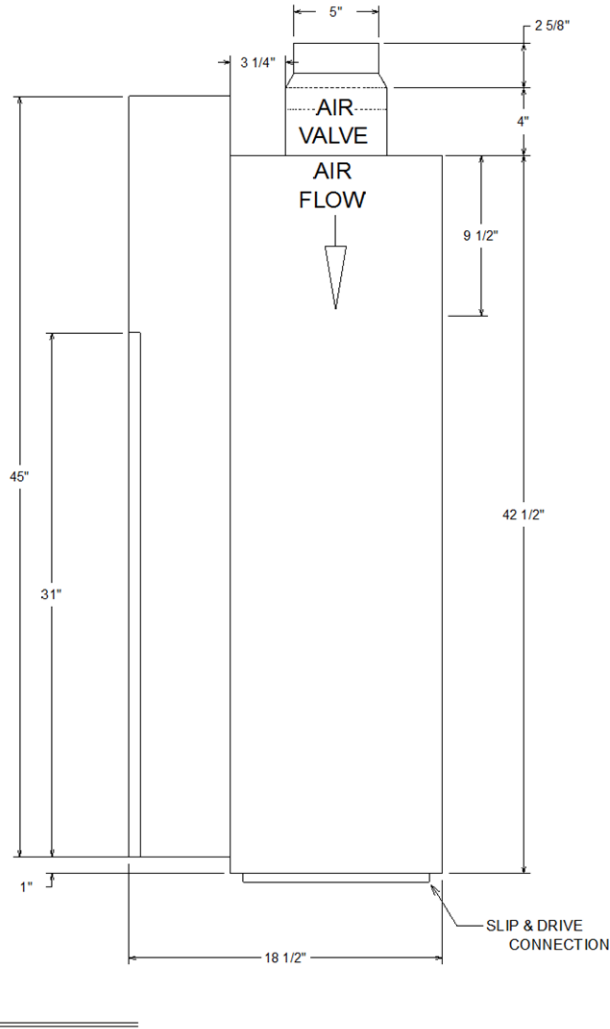

BACK VIEW

Approximate Dry Weight	81.7 lb
------------------------	---------

Weight reflected may vary 5 lbs(2.27kgs) based upon options selected.

Dimensional Drawings - Variable Air Volume Single Duct Terminal Units

Item: A4, A8, A11, A17, A31, A33 Qty: 6 Tag(s): VAV 1-4, VAV 1-8, VAV 1-11, VAV 1-17, VAV 2-7, VAV 2-9

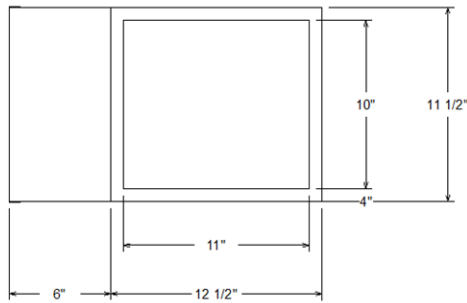
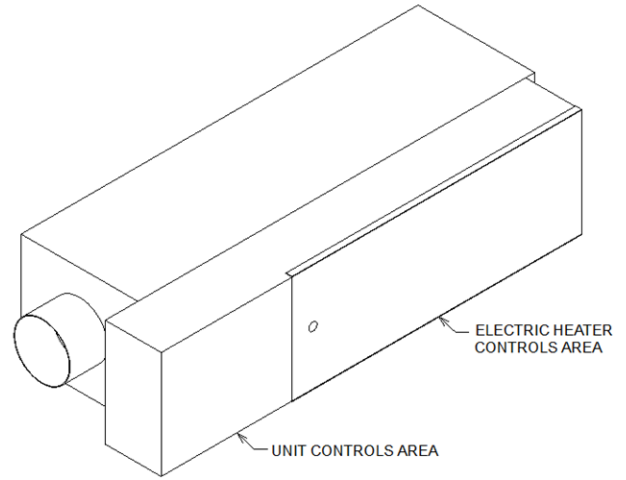
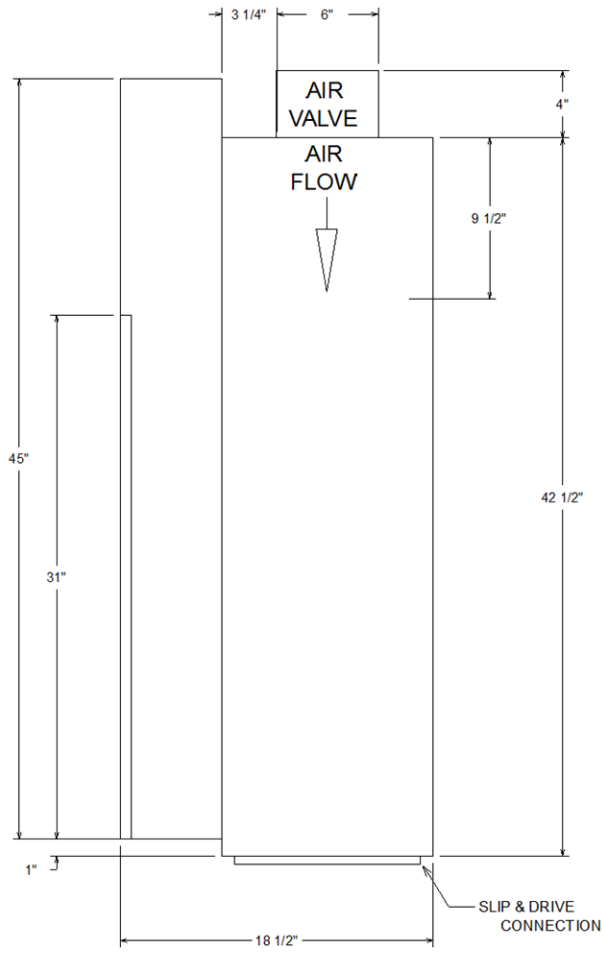

BACK VIEW

Approximate Dry Weight	81.7 lb
------------------------	---------

Weight reflected may vary 5 lbs(2.27kgs) based upon options selected.

Dimensional Drawings - Variable Air Volume Single Duct Terminal Units

Item: A5, A9, A10, A21, A26, A27, A30, A32 Qty: 8 Tag(s): VAV 1-5, VAV 1-9, VAV 1-10, VAV 1-21, VAV 2-2, VAV 2-3, VAV 2-6, VAV 2-8

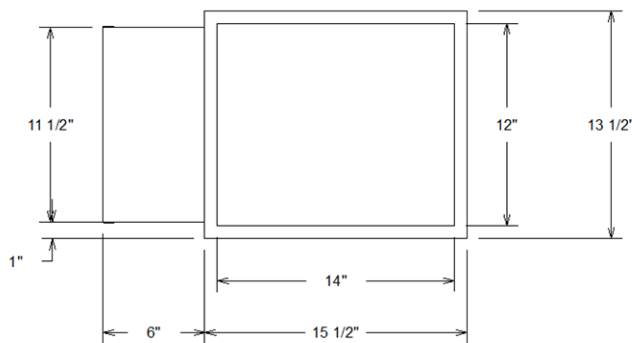
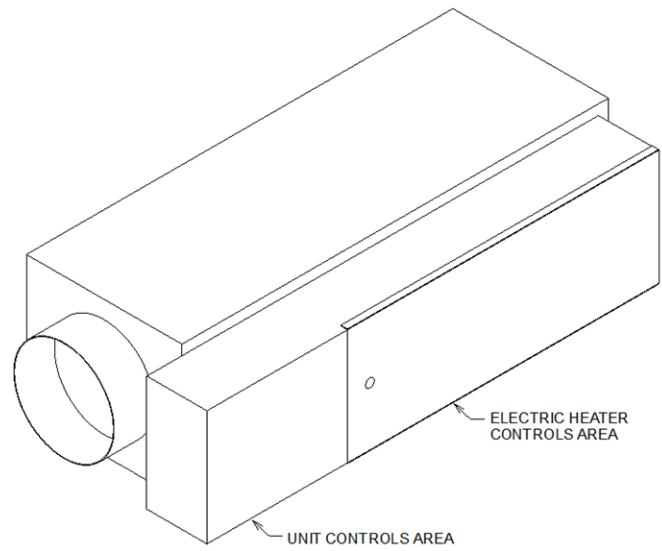
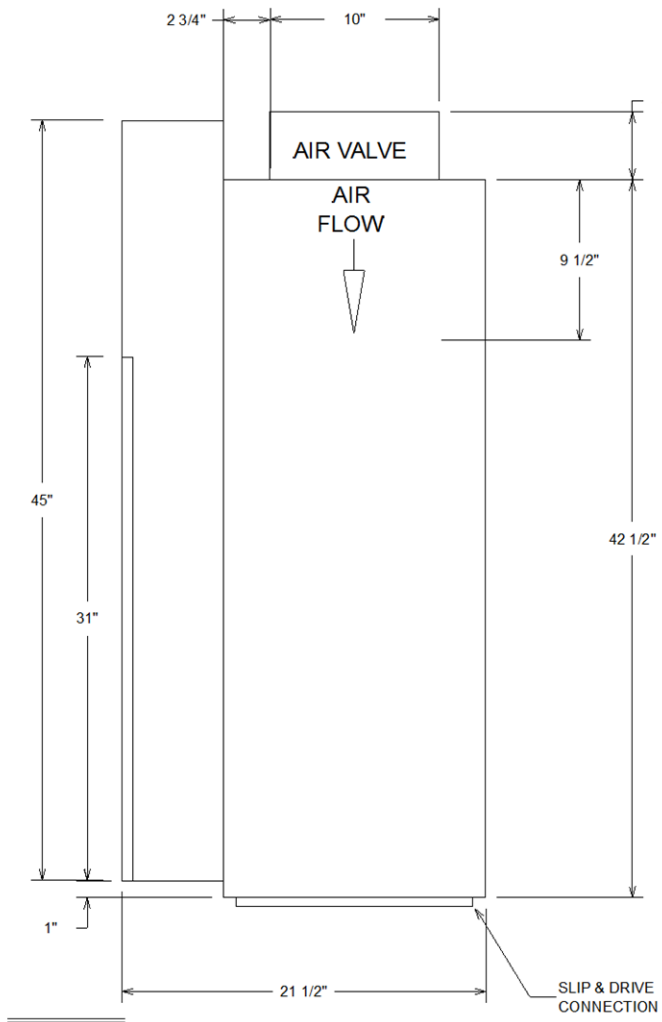

BACK VIEW

Approximate Dry Weight	101.0 lb
------------------------	----------

Weights reflected may vary ±5.0 lb based upon options selected.

Dimensional Drawings - Variable Air Volume Single Duct Terminal Units

Item: A13, A15, A16, A19, A20, A22, A25, A28 Qty: 8 Tag(s): VAV 1-13, VAV 1-15, VAV 1-16, VAV 1-19, VAV 1-20, VAV 1-22, VAV 2-1, VAV 2-4

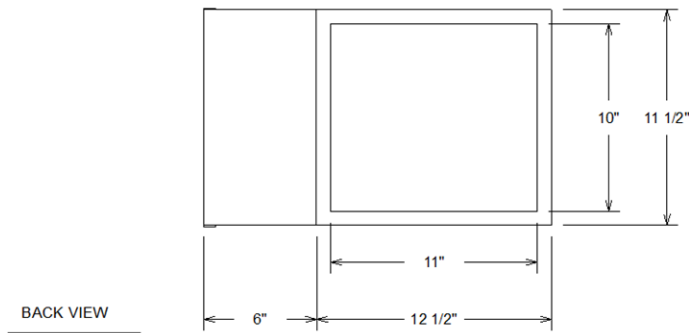
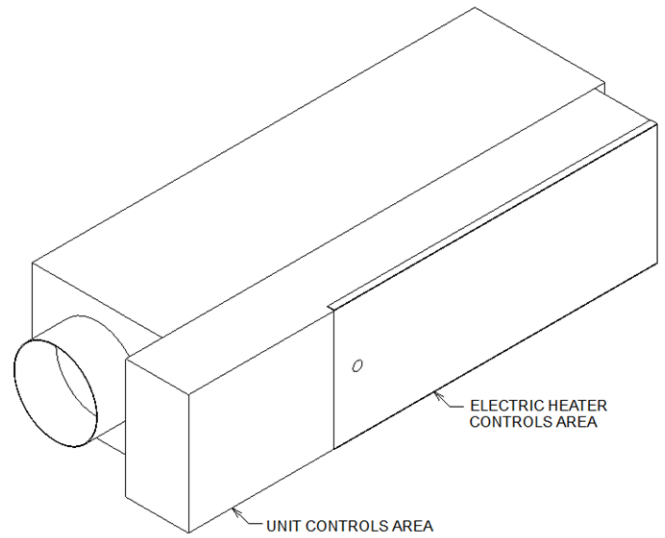
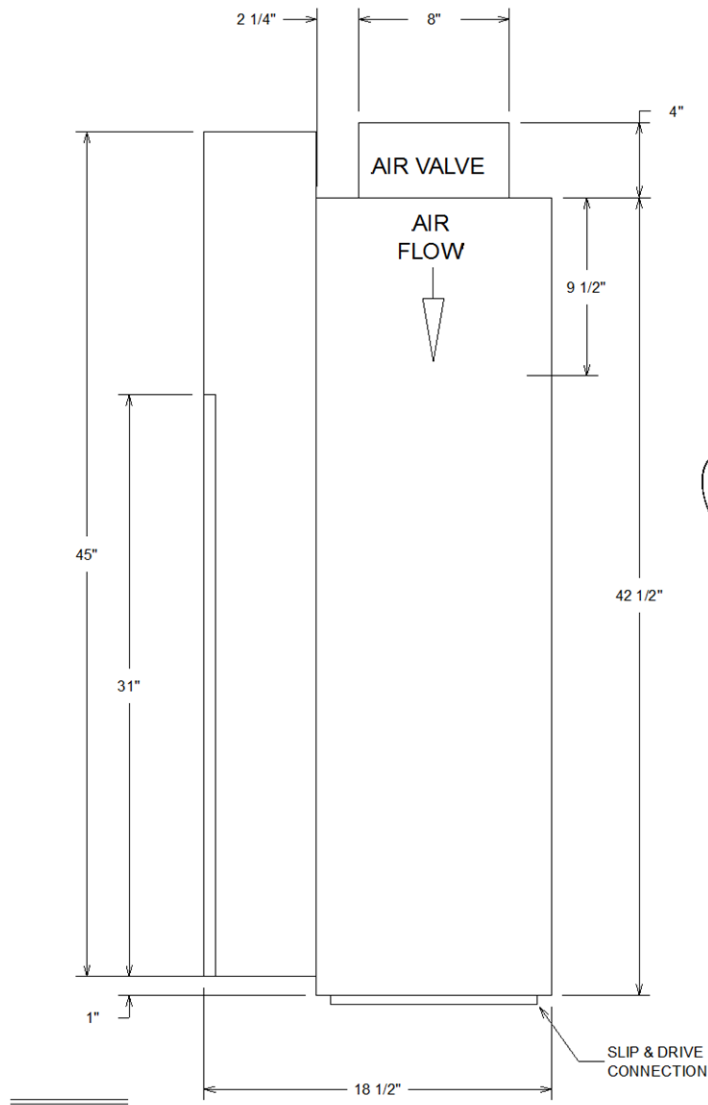

Approximate Dry Weight	84.7 lb
------------------------	---------

Weights reflected may vary ±5.0 lb based upon options selected.

Dimensional Drawings - Variable Air Volume Single Duct Terminal Units

Item: A24 Qty: 1 Tag(s): VAV 1-24

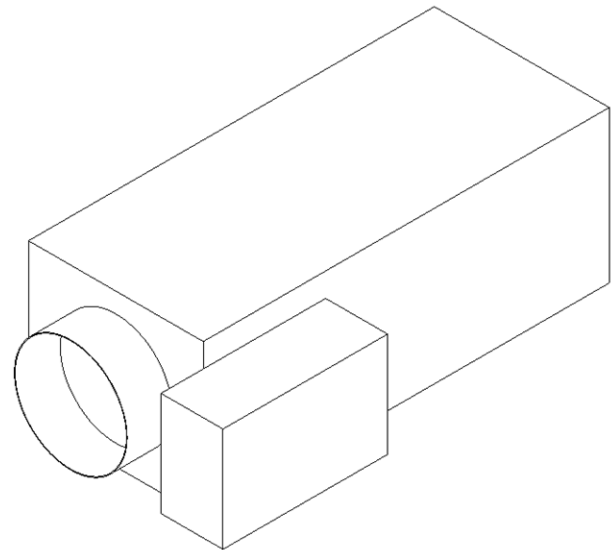
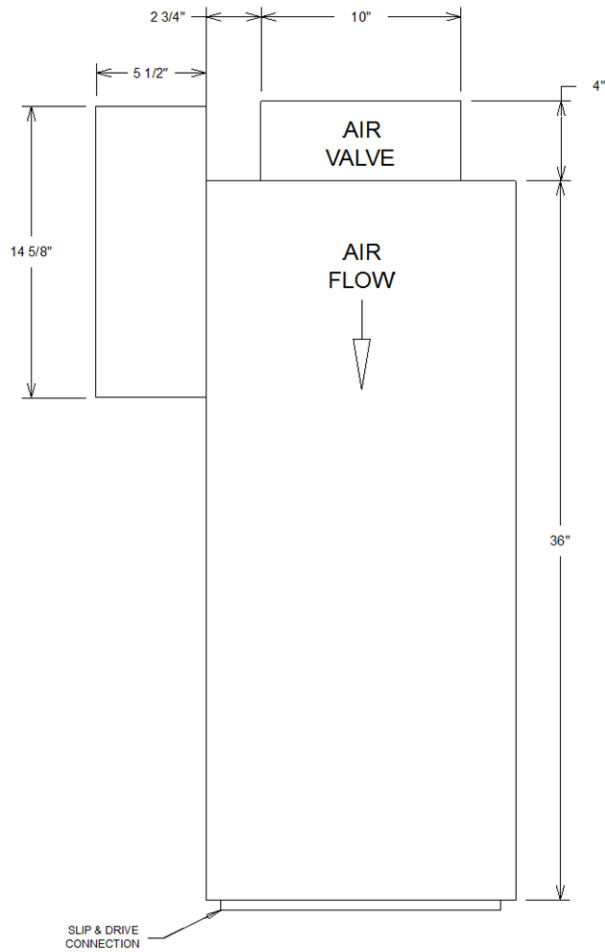

Customer Notes

1. Air Inlet is centered in unit front panel.
2. Slip & Drive discharge outlet standard.
3. Minimum of 1.5 duct diameters of straight duct required at inlet for proper flow reading.
4. Allow 36" on control side for servicing.
5. Optional Bottom Access is centered 2" from discharge end on the bottom of the unit.
6. Bottom Access Door - 9" x 9".
26 GA galvanized steel with a 1" thick insulation encapsulated with a 26 GA liner.

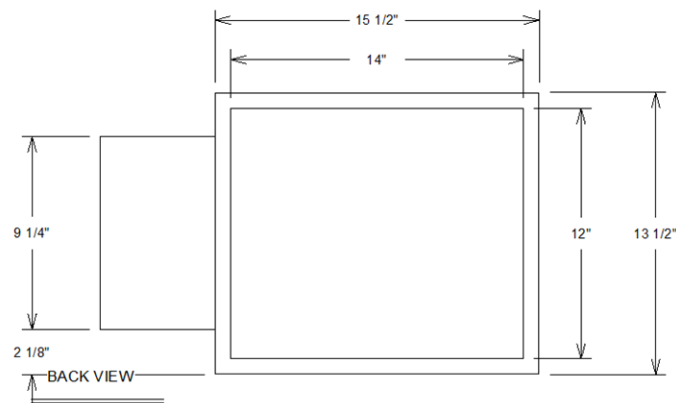

Approximate Dry Weight	50.0 lb
------------------------	---------

Weights reflected may vary ±5.0 lb based upon options selected.

Dimensional Drawings - Variable Air Volume Single Duct Terminal Units

Item: A29 Qty: 1 Tag(s): VAV 2-5

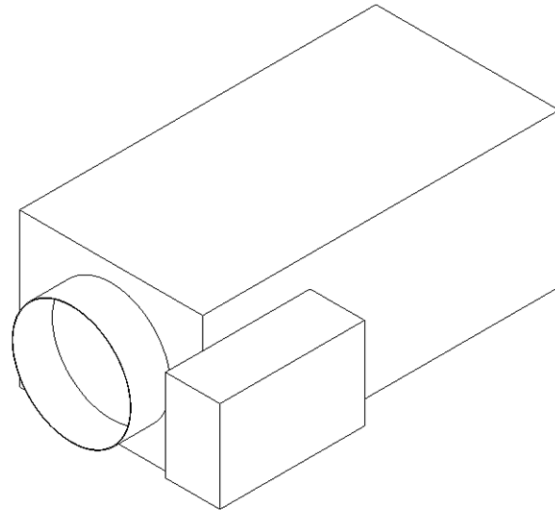
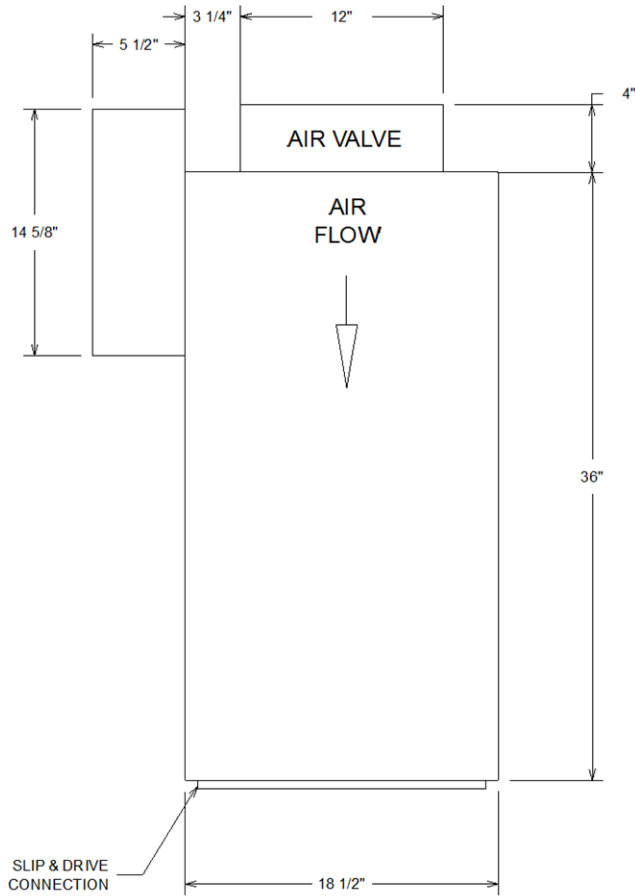

Customer Notes

1. Air Inlet is centered in unit front panel.
2. Slip & Drive discharge outlet standard.
3. Minimum of 1.5 duct diameters of straight duct required at inlet for proper flow reading.
4. Allow 36" on control side for servicing.
5. Optional Bottom Access is centered 2" from discharge end on the bottom of the unit.
6. Bottom Access Door - 9" x 9".
26 GA galvanized steel with a 1" thick insulation encapsulated with a 26 GA liner.

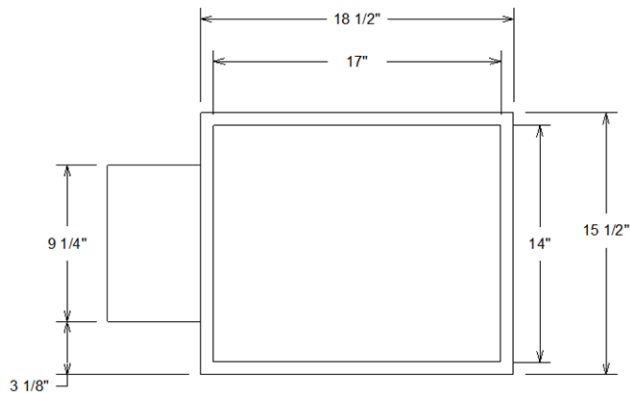

BACK VIEW

Approximate Dry Weight	59.7 lb
------------------------	---------

Weights reflected may vary ±5.0 lb based upon options selected.

Field Wiring - Variable Air Volume Single Duct Terminal Units

Item: A1 - A4, A6 - A8, A11 - A14, A18, A23, A28, A33 Qty: 15 Tag(s): VAV 1-1, VAV 1-2, VAV 1-3, VAV 1-4, VAV 1-6, VAV 1-7, VAV 1-8, VAV 1-11, VAV 1-12, VAV 1-13, VAV 1-14, VAV 1-18, VAV 1-23, VAV 2-4, VAV 2-9

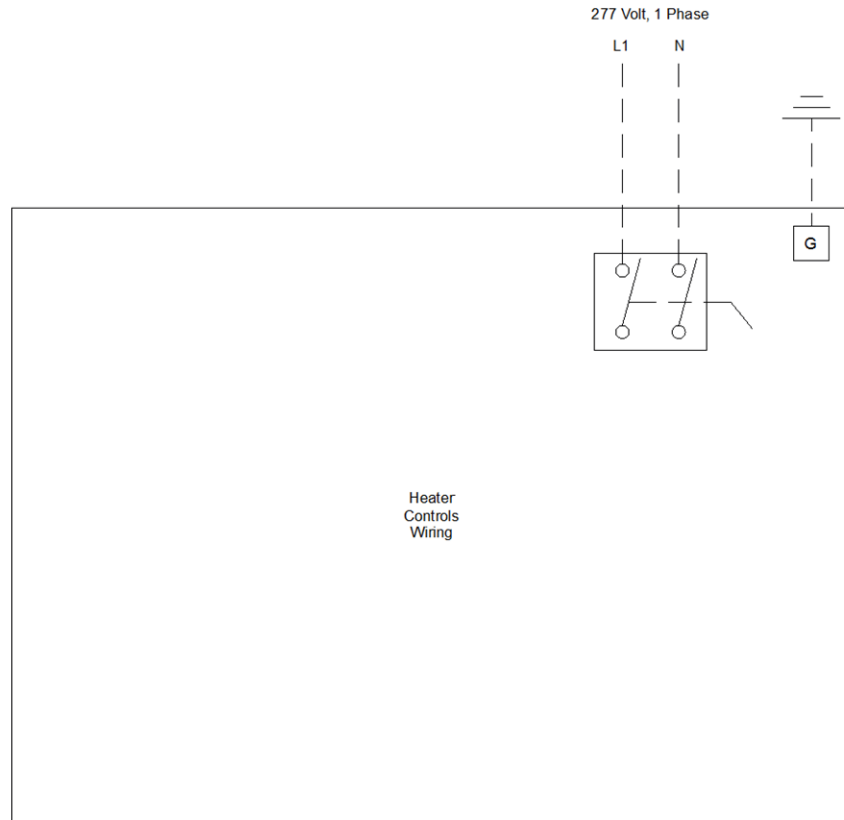

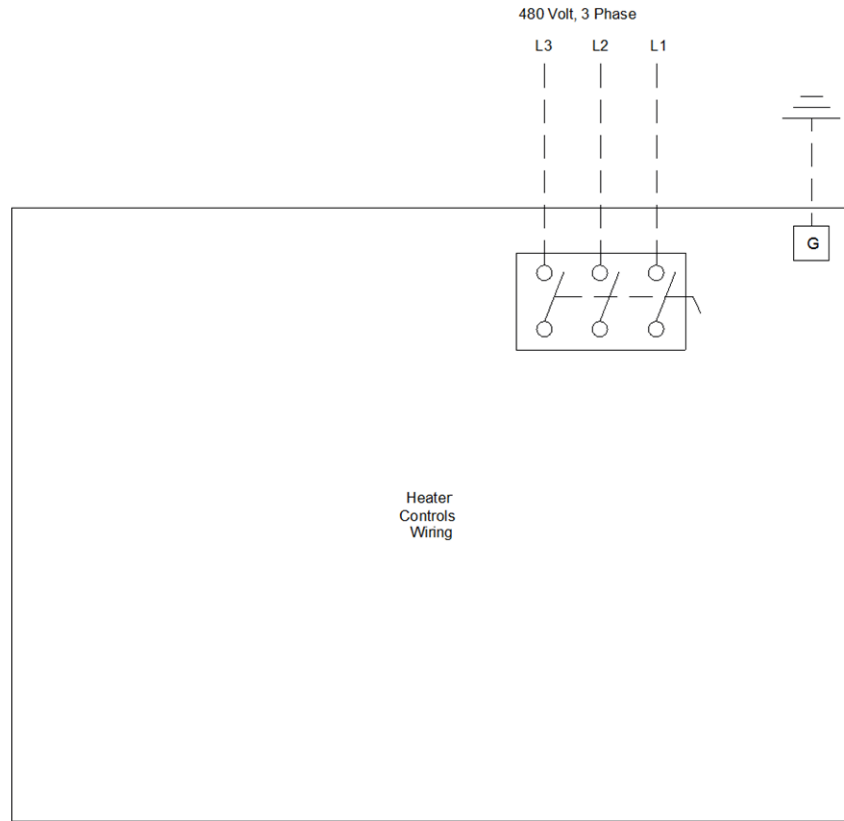

Field Wiring - Variable Air Volume Single Duct Terminal Units

Item: A5, A9, A10, A15 - A17, A19 - A22, A25 - A27, A30 - A32 Qty: 16 Tag(s): VAV 1-5, VAV 1-9, VAV 1-10, VAV 1-15, VAV 1-16, VAV 1-17, VAV 1-19, VAV 1-20, VAV 1-21, VAV 1-22, VAV 2-1, VAV 2-2, VAV 2-3, VAV 2-6, VAV 2-7, VAV 2-8

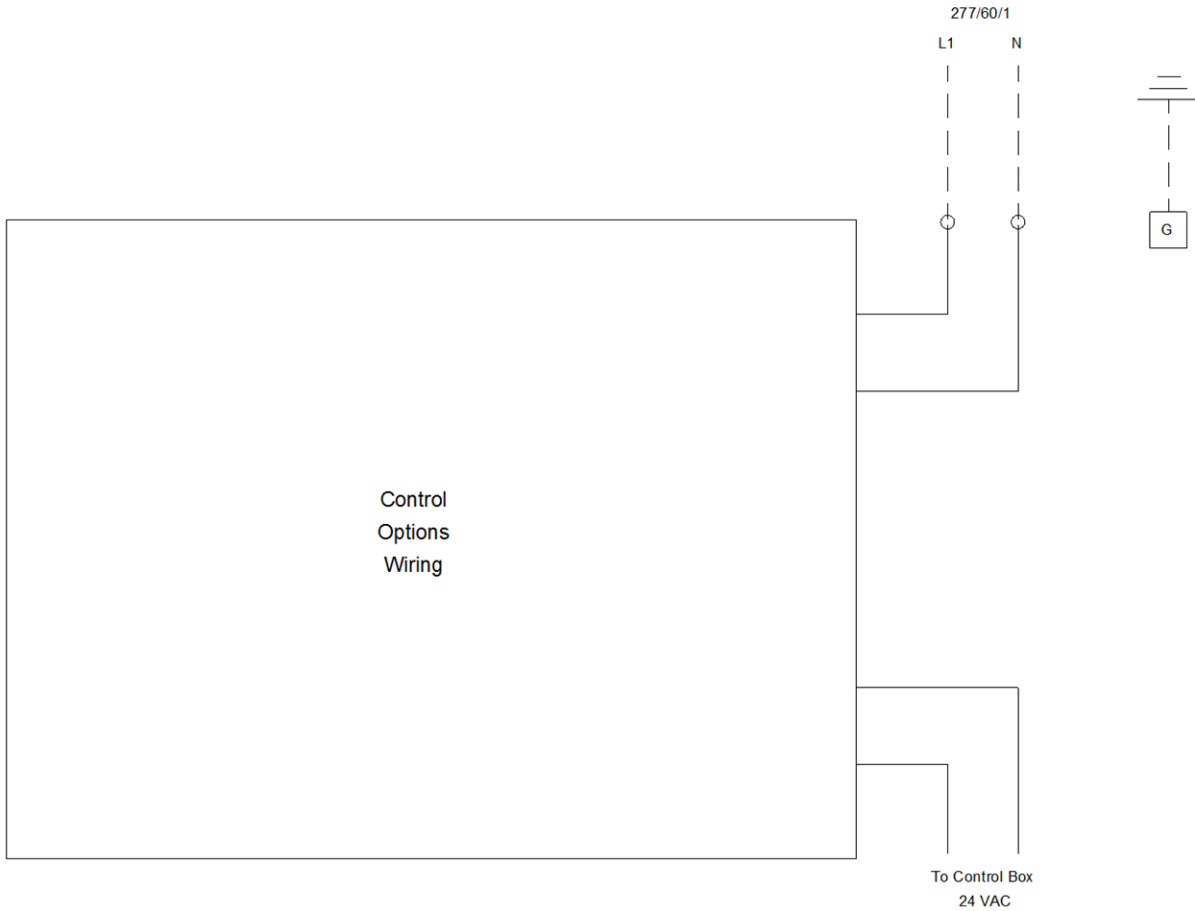

Field Wiring - Variable Air Volume Single Duct Terminal Units
Item: A24, A29 Qty: 2 Tag(s): VAV 1-24, VAV 2-5



	<p>WARNING</p> <p>HAZARDOUS VOLTAGE! DISCONNECT ALL ELECTRIC POWER INCLUDING REMOTE DISCONNECTS BEFORE SERVICING. FAILURE TO DISCONNECT POWER BEFORE SERVICING CAN CAUSE SEVERE PERSONAL INJURY OR DEATH</p>
	<p>CAUTION</p> <p>USE COPPER CONDUCTORS ONLY! UNIT TERMINALS ARE NOT DESIGNED TO ACCEPT OTHER TYPES OF CONDUCTORS. FAILURE TO DO SO MAY CAUSE DAMAGE TO THE EQUIPMENT.</p>

Customer Notes:

- 1. ————— Factory installed.
- - - - - Optional or installed by others.