

FOR QUESTIONS, CALL THE
Highwoods Group
REGION 40
PHONE: (919) 875-0420
EMAIL: reg40@captivaire.com

PATENT NUMBERS

AC-PSP (UNITED STATES) - US PATENT 7963830 B2.
AC-PSP WALL (CANADA) - CA PATENT 2820509.
AC-PSP ISLAND (CANADA) - CA PATENT 2520330.

HOOD INFORMATION - JOB#5211062

HOOD NO	TAG	MODEL	MANUFACTURER	LENGTH	MAX COOKING TEMP	TYPE	APPLIANCE DUTY	DESIGN CFM/FT	TOTAL EXH CFM	EXHAUST PLENUM RISER(S)						MUA CFM	AC CFM	HOOD CONSTRUCTION	HOOD CONFIG	
										WIDTH	LENG	HEIGHT	DIA	CFM	VEL				SP	END TO END
1		5424 ND-2-ACPSP-F	CAPTIVEAIRE	14' 3"	600 DEG	I	HEAVY	225	3200	10'	15'	4'	1600	1536	-0.854'	1950	798	430 SS WHERE EXPOSED	ALONE	ALONE

HOOD INFORMATION

HOOD NO	TAG	FILTER(S)				LIGHT(S)				UTILITY CABINET(S)				FIRE SYSTEM PIPING	HOOD HANGING WEIGHT		
		TYPE	QTY	HEIGHT	LENGTH	EFFICIENCY @ 7 MICRONS	QTY	TYPE	WIRE GUARD	LOCATION	SIZE	FIRE SYSTEM TYPE	SIZE			ELECTRICAL MODEL #	SWITCHES QUANTITY
1		CAPTRATE SOLID FILTER	10	16"	16"	85% SEE FILTER SPEC	10	L55 SERIES E26	NO	LEFT	12"x54"x24"	ANSUL R-102	3.0/3.0	SC-311110MA	1 LIGHT 1 FAN	YES	1080 LBS

HOOD OPTIONS

HOOD NO	TAG	OPTION
1		FIELD WRAPPER 6.00" HIGH FRONT, RIGHT.
		FIELD WRAPPER 18.00" HIGH LEFT.
		RIGHT QUARTER END PANEL 23" TOP WIDTH, 0" BOTTOM WIDTH, 23" HIGH 430 SS.
		LEFT QUARTER END PANEL 23" TOP WIDTH, 0" BOTTOM WIDTH, 23" HIGH 430 SS.
		INSULATION FOR BACK OF HOOD.
		FULL DIMENSION HANGING BRACKET - FRONT.

PERFORATED SUPPLY PLENUM(S)

HOOD NO	TAG	POS	LENGTH	WIDTH	HEIGHT	TYPE	RISER(S)				
							WIDTH	LENG	DIA	CFM	SP
1		Front	183'	22'	6'	MUA	10"	28"		650	0.166'
						MUA	10"	28"		650	0.166'
						MUA	10"	28"		650	0.166'
						AC		8"	114	0.041'	
						AC		8"	114	0.041'	
						AC		8"	114	0.041'	
						AC		8"	114	0.041'	
						AC		8"	114	0.041'	
						AC		8"	114	0.041'	
						AC		8"	114	0.041'	

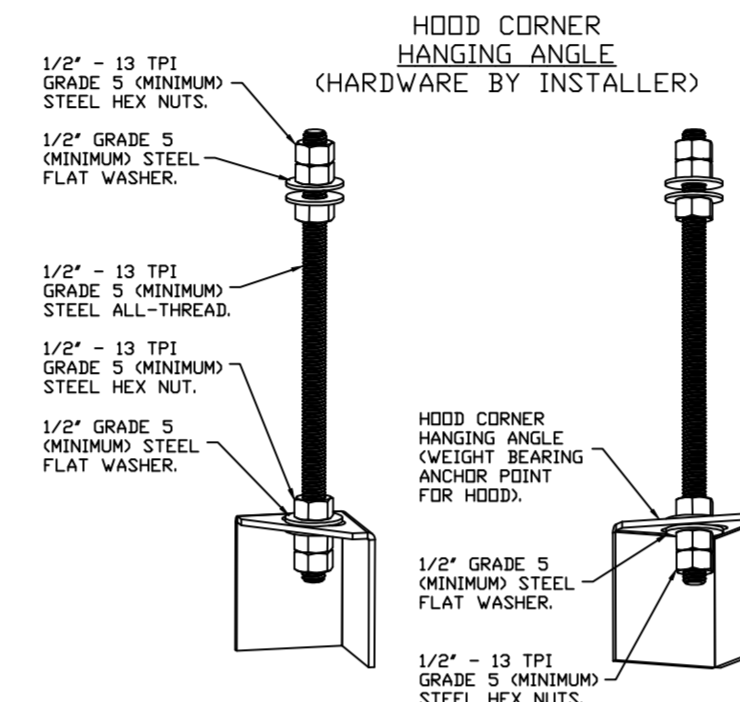

ASSEMBLY INSTRUCTIONS

HANGING ANGLE MUST BE SUPPORTED WITH 1/2" - 13 TPI GRADE 5 (MINIMUM) ALL-THREAD. SANDWICH HANGING ANGLES AND CEILING ANCHOR POINTS WITH 1/2" GRADE 5 (MINIMUM) STEEL FLAT WASHERS AND 1/2" - 13 TPI GRADE 5 (MINIMUM) HEX NUTS AS SHOWN. MUST USE DOUBLED HEX NUT CONFIGURATION BENEATH HOOD HANGING ANGLES AND ABOVE CEILING ANCHORS. MAINTAIN 1/4" OF EXPOSED THREADS BENEATH BOTTOM HEX NUT. TORQUE ALL HEX NUTS TO 57 FT-LBS.

SPECIFICATION: CAPTRATE® GREASE-STOP® SOLID FILTER

THE CAPTRATE GREASE-STOP SOLID FILTER IS A SINGLE-STAGE FILTER FEATURING A UNIQUE S-BAFFLE DESIGN IN CONJUNCTION WITH A SLOTTED REAR BAFFLE DESIGN, TO DELIVER EXCEPTIONAL FILTRATION EFFICIENCY.

FILTER IS STAINLESS STEEL CONSTRUCTION, AND SIZED TO FIT INTO STANDARD 2-INCH DEEP HOOD CHANNEL(S).

UNITS SHALL INCLUDE STAINLESS STEEL HANDLES AND A FASTENING DEVICE TO SECURE THE TWO COMPONENTS WHEN ASSEMBLED.

GREASE EXTRACTION EFFICIENCY PERFORMANCE SHALL REMOVE AT LEAST 75% OF GREASE PARTICLES FIVE MICRONS IN SIZE, AND 85% GREASE PARTICLES SEVEN MICRONS IN SIZE AND LARGER, WITH A CORRESPONDING PRESSURE DROP NOT TO EXCEED 1.0 INCHES OF WATER GAUGE.

THE CAPTRATE GREASE-STOP SOLID WAS TESTED TO ASTM STANDARD ASTM F2519-05, MANUFACTURER APPROVED FOR USE IN SOLID FUEL APPLICATIONS AS A SPARK ARRESTER.

EFFICIENCY VS. PARTICLE DIAMETER

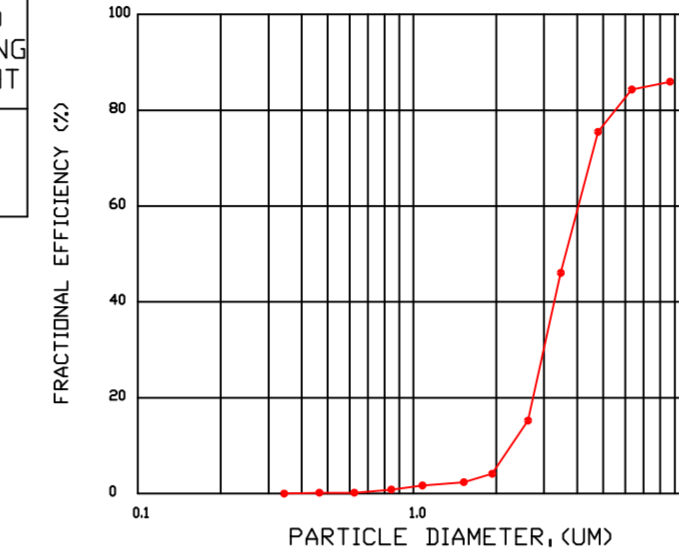

PRESSURE DROP VS. FLOW RATE

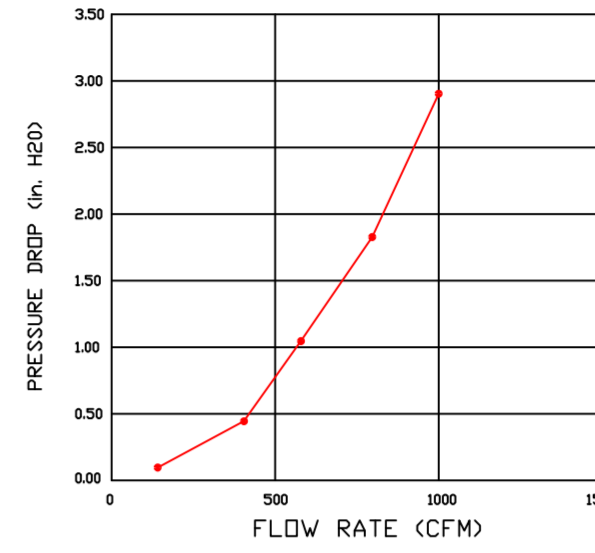

CAPTRATE FILTERS ARE BUILT IN COMPLIANCE WITH:
NFPA #96.
NSF STANDARD #2.
UL STANDARD #1046.
INT. MECH. CODE (IMC).
ULC-S649.

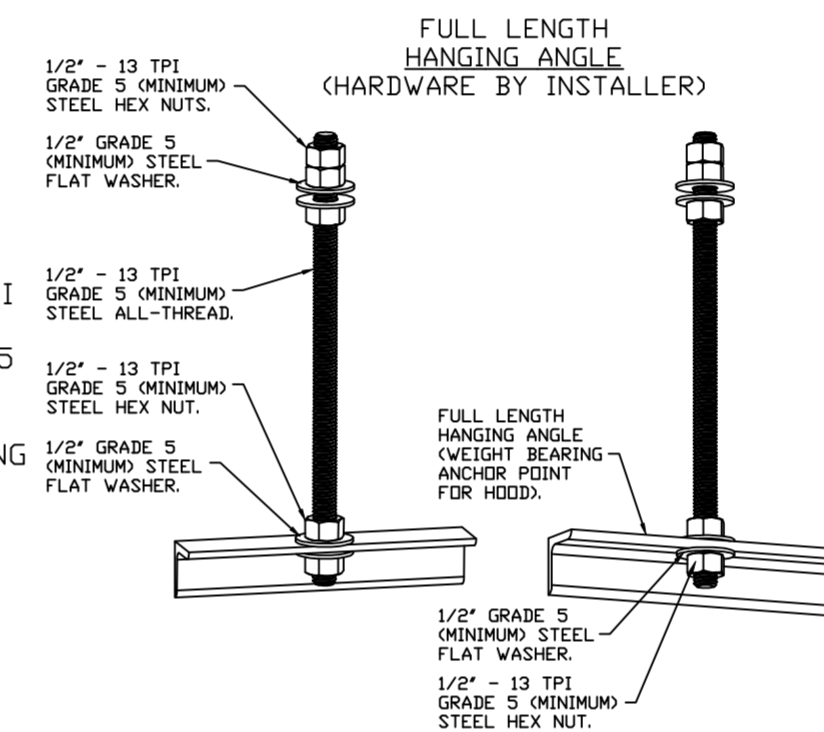

ASSEMBLY INSTRUCTIONS

HANGING ANGLE MUST BE SUPPORTED WITH 1/2" - 13 TPI GRADE 5 (MINIMUM) ALL-THREAD. SANDWICH HANGING ANGLES AND CEILING ANCHOR POINTS WITH 1/2" GRADE 5 (MINIMUM) STEEL FLAT WASHERS AND 1/2" - 13 TPI GRADE 5 (MINIMUM) HEX NUTS AS SHOWN. MUST USE DOUBLED HEX NUT CONFIGURATION ABOVE CEILING ANCHORS. SINGLE HEX NUT BENEATH HANGING ANGLE IS ACCEPTABLE FOR FULL LENGTH HANGING ANGLES. MAINTAIN 1/4" OF EXPOSED THREADS BENEATH BOTTOM HEX NUT. TORQUE ALL HEX NUTS TO 57 FT-LBS.

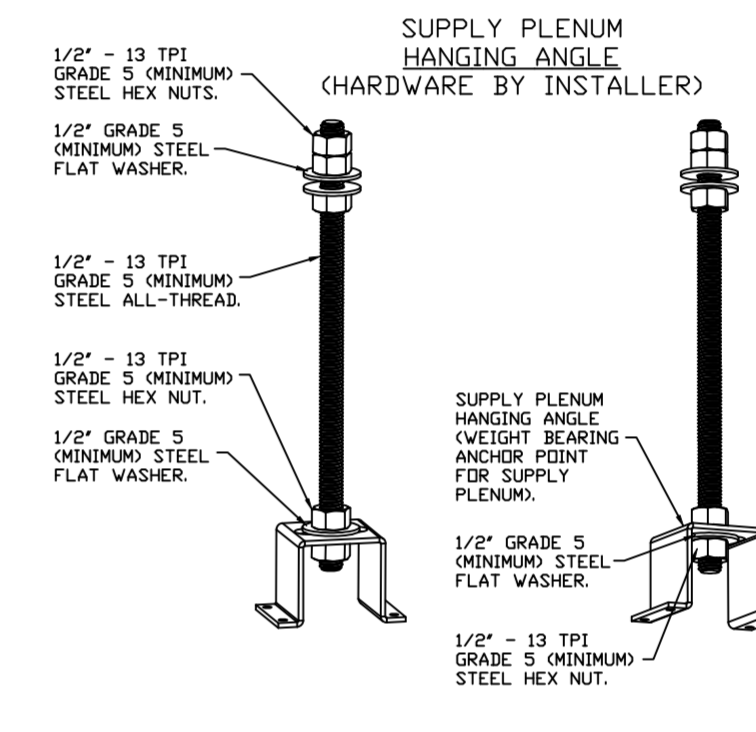

ASSEMBLY INSTRUCTIONS

HANGING ANGLE MUST BE SUPPORTED WITH 1/2" - 13 TPI GRADE 5 (MINIMUM) ALL-THREAD. SANDWICH HANGING ANGLES AND CEILING ANCHOR POINTS WITH 1/2" GRADE 5 (MINIMUM) STEEL FLAT WASHERS AND 1/2" - 13 TPI GRADE 5 (MINIMUM) HEX NUTS AS SHOWN. MUST USE DOUBLED HEX NUT CONFIGURATION ABOVE CEILING ANCHORS. SINGLE HEX NUT BENEATH HANGING ANGLE IS ACCEPTABLE FOR PSP HANGING ANGLES. MAINTAIN 1/4" OF EXPOSED THREADS BENEATH BOTTOM HEX NUT. TORQUE ALL HEX NUTS TO 57 FT-LBS.

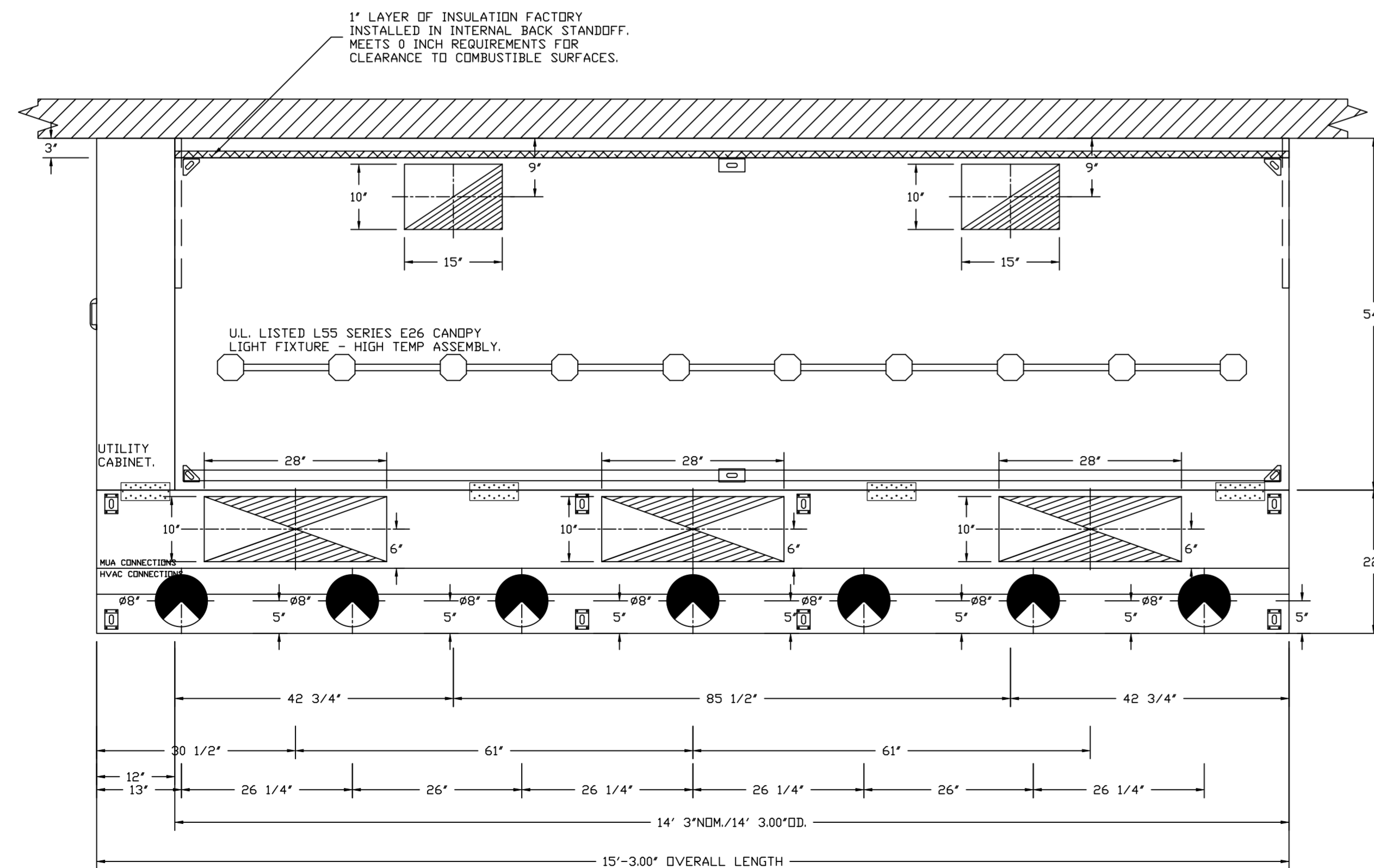

PLAN VIEW - HOOD #1
14' 3.00" LONG 5424ND-2-ACPSP-F
NOTE: ADDITIONAL HANGING ANGLES PROVIDED FOR HOODS 12' AND LONGER.

ACPSP SHIPS LOOSE FOR FIELD INSTALLATION

REVISIONS

DESCRIPTION	DATE

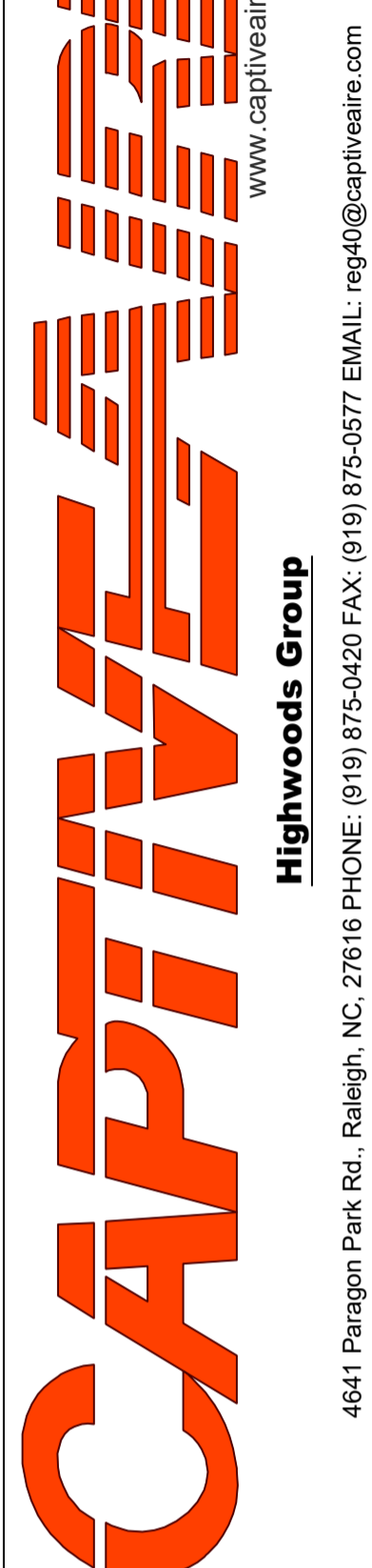
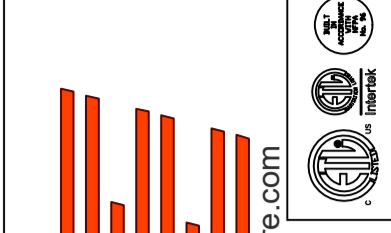

CHIPOTLE RICHMOND CENTRAL #4321
RICHMOND, BC, V6X 0M6

DATE: 3/14/2022

DWG.#:
5211062

DRAWN BY: JMB-40

SCALE:
3/4" = 1'-0"

MASTER DRAWING

SHEET NO.
1

4641 Paragon Park Rd., Raleigh, NC, 27616 PHONE: (919) 875-0420 FAX: (919) 875-0577 EMAIL: reg40@captivaire.com

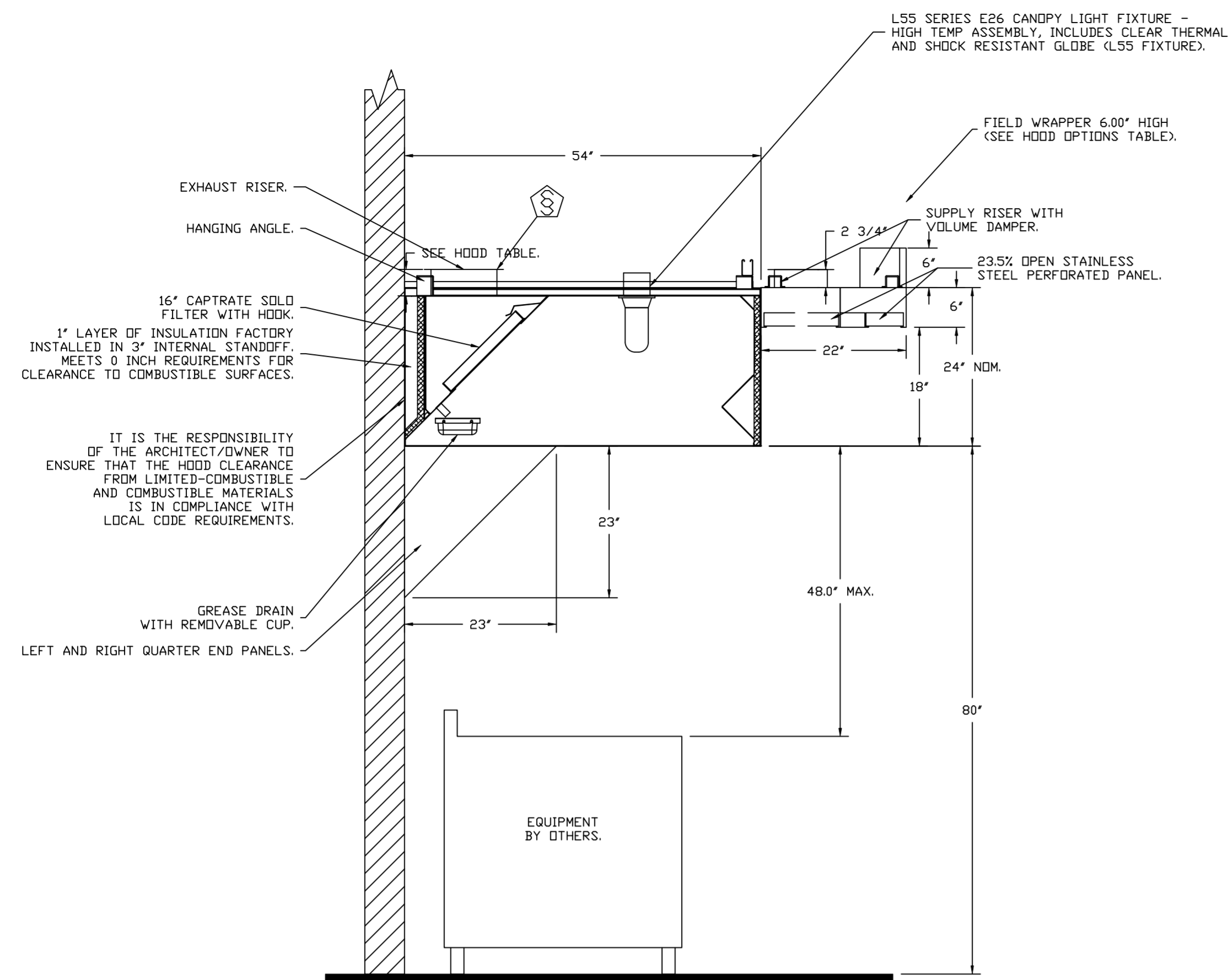

SECTION VIEW - MODEL 5424ND-2-ACPSP-F
HOOD - #1

SYSTEM DESIGN VERIFICATION (SDV)

IF ORDERED, CAS SERVICE WILL PERFORM A SYSTEM DESIGN VERIFICATION (SDV) ONCE ALL EQUIPMENT HAS HAD A COMPLETE START UP PER THE OPERATION AND INSTALLATION MANUAL. TYPICALLY, THE SDV WILL BE PERFORMED AFTER ALL INSPECTIONS ARE COMPLETE.

ANY FIELD RELATED DISCREPANCIES THAT ARE DISCOVERED DURING THE SDV WILL BE BROUGHT TO THE ATTENTION OF THE GENERAL CONTRACTOR AND CORRESPONDING TRADES ON SITE. THESE ISSUES WILL BE DOCUMENTED AND FORWARDED TO THE APPROPRIATE SALES OFFICE. IF CAS SERVICE HAS TO RESOLVE A DISCREPANCY THAT IS A FIELD ISSUE, THE GENERAL CONTRACTOR WILL BE NOTIFIED AND BILLED FOR THE WORK. SHOULD A RETURN TRIP BE REQUIRED DUE TO ANY FIELD RELATED DISCREPANCY THAT CANNOT BE RESOLVED DURING THE SDV, THERE WILL BE ADDITIONAL TRIP CHARGES.

DURING THE SDV, CAS SERVICE WILL ADDRESS ANY DISCREPANCY THAT IS THE FAULT OF THE MANUFACTURER. SHOULD A RETURN TRIP BE REQUIRED, THE GENERAL CONTRACTOR AND APPROPRIATE SALES OFFICE WILL BE NOTIFIED. THERE WILL BE NO ADDITIONAL CHARGES FOR MANUFACTURER DISCREPANCIES.

REVISIONS

DESCRIPTION	DATE

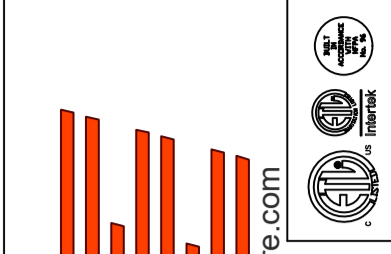

CAPTIVE AIR
Highwoods Group
www.captiveair.com
4641 Paragon Park Rd., Raleigh, NC 27616 PHONE: (919) 875-0420 FAX: (919) 875-0577 EMAIL: reg10@captiveair.com

CHIPOTLE RICHMOND CENTRAL #4321
RICHMOND, BC, V6X 0M6

DATE: 3/14/2022

DWG.#: 5211062

DRAWN BY: JMB-40

SCALE: 3/4" = 1'-0"

MASTER DRAWING

SHEET NO.
2

SPECIFICATIONS

TAG: Commercial Kitchen Ventilation Hoods, Listed Commercial Kitchen Hoods

PART 1 - GENERAL

1.1 SUMMARY

- A. The ND2 series is a Type I, wall canopy hood for use over 600°F cooking surface temperatures. The aerodynamic design includes a mechanical baffle and performance enhancing lip for exceptional capture and containment.
- B. The hood shall have the size, shape, and performance specified on drawings.

1.2 SUBMITTALS

- A. The manufacturer assumes no liability for the use or results of use from this document. Specifications are to be reviewed by the engineer to confirm the project's requirements and meet Federal, State, and Local codes and regulations.
- B. As the manufacturer continues product development, it reserves the right to change design and specifications without notice.
- C. The manufacturer shall supply complete computer generated submittal drawings, including hood section view(s) and hood plan view(s). These drawings must be available to the engineer, architect, and owner for their use in construction, operation, and maintenance.

1.3 QUALITY ASSURANCE

- A. This hood is ETL-listed to standard UL710, ULC710, and ULC-S646 when installed in accordance with these installation instructions and National Fire Protection Association Standard NFPA 96, Standard for Ventilation Control and Fire Protection of Commercial Cooking Operations."
- B. Built-in compliance with NSF/ANSI Standard 2.
- C. The hood shall be ETL Listed as:
1. "Exhaust Hood Without Exhaust Damper."
 2. ETL Sanitation Listed and built in accordance with NFPA 96.
 3. The ETL label shall list temperature rating(s) and minimum CFM/ft rating(s).

1.4 WARRANTY

- A. All units shall be provided with the following standard warranty:
1. This equipment is warranted to be free from defects in materials and workmanship, under normal use and service, for a period of 2-years from date of shipment.
- B. The manufacturer shall not be liable for incidental and consequential losses and damages potentially attributable to malfunctioning equipment. Should any part of the equipment prove to be defective in material or workmanship within the 2-year warranty period, upon examination by the manufacturer, such part will be repaired or replaced by manufacturer at no charge. The buyer shall pay all labor costs incurred in connection with such repair or replacement. Equipment shall not be returned without manufacturer's prior authorization, and all returned equipment shall be shipped by the buyer, freight prepaid to a destination determined by the manufacturer.
- C. Refer to Manufacturer's Operation, Installation, and Maintenance (OIM) Manual for detailed descriptions of what is/is not covered and contact information for warranty claims.

PART 2 - PRODUCTS

2.1 GENERAL

- A. Construction shall be dependent on the structural application to minimize distortion and other defects. All seams, joints, and penetrations of the hood enclosure to the lower outermost perimeter, which directs and captures grease-laden vapor and exhaust gases, shall have a liquid-tight continuous external weld in accordance with NFPA 96.

- B. Duct sizes, CFM, and static pressure requirements shall be as shown on drawings. Static pressure requirements shall be precise and accurate; air velocity and volume information shall be accurate within 1-ft increments along the length of the ventilator.

2.2 CONSTRUCTION

- A. Construction shall be type 430 stainless steel.
- B. Double wall insulated front to eliminate condensation and increase rigidity on wide sizes. The insulation shall have a flexural modulus of 475 EI, meet UL 181 requirements and be in accordance with NFPA 90A and 90B.
- C. Hood shall be equipped with a minimum of four connections for hanger rods. Hood lengths greater than 12' will have added hangers.
- D. Exhaust duct collar to be 4" high with flange.
- E. The grease drain system shall be an enclosed integral part of the hood back and have slopes with an exposed, removable 1/2 grease cup to facilitate cleaning.
- F. An integral baffle to direct grease laden vapors toward the exhaust filter bank.
- G. Hood shall be furnished with UL classified filters, supplied in size and quantity as required by ventilator.
- H. All seams shall be welded and have stainless steel on exposed surfaces.

2.3 LIGHTING

- A. L55 Series canopy light fixture, includes clear thermal and shock resistant globe.

2.4 FILTERS

- A. Stainless Steel Captrate Solo filter with hook, ETL Listed. Particulate capture efficiency: 85% efficient at 9 microns, 76% efficient at 5 microns.

2.5 OPTIONS

- A. Fire Suppression System: UL 300 fire suppression system.
- B. Optional perforated supply plenum shall provide make-up air discharged below the cooking equipment.
1. Perforated diffuser plates shall be included in the design to provide even air distribution.
 2. Unexposed surfaces shall be constructed of aluminized steel. Plenum shall be insulated to prevent condensation.
 3. Dual Plenum (AC-PSP)
- C. Hood Mounted Utility Cabinet - Cabinet can store listed fire suppression system, listed components, pre-wired electrical controls.

2.6 ACCESSORIES

- A. End Panel(s) maximize hood performance and eliminate the effects of cross drafts in the kitchen. Units constructed of stainless steel and sized according to hood width and cooking equipment. Exposed edges hemmed for safety and rigidity. Selected panels:
1. Quarter End Panel
- B. Wrapper(s) may be installed from the factory or field installed. Wrapper(s) selected:
1. Wrapper
- C. Miscellaneous option(s) selected:
1. Full Dimension Hanging Bracket -Unistrut added to allow for various hood mounting locations.
 2. Insulation for Back of Hood -Backside of hood is fully insulated.

PART 3 - EXECUTION

3.1 EXAMINATION

- A. Examine areas and conditions under which the system is installed. Do not proceed with work until unsatisfactory conditions have been

corrected in a manner acceptable to Installer.

3.2 INSTALLATION

- A. Install in accordance with manufacturer's instructions, drawings, written specifications, manufacturer's installation manual, and all applicable building codes.

REVISIONS

DESCRIPTION	DATE
Δ	
Δ	
Δ	
Δ	

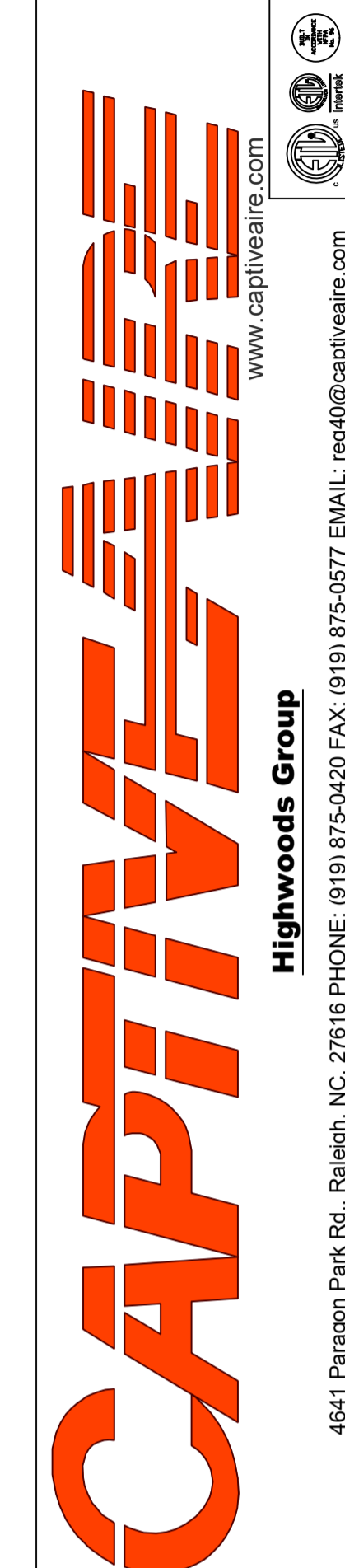

CHIPOTLE RICHMOND CENTRAL #4321
RICHMOND, BC, V6X 0M6

DATE: 3/14/2022

DWG.#:
5211062DRAWN
BY: JMB-40SCALE:
3/4" = 1'-0"

MASTER DRAWING

SHEET NO.

3

FIRE SYSTEM INFORMATION - JOB#5211062

FIRE SYSTEM NO	TAG	TYPE	SIZE	FLOW POINTS	INSTALLATION	
					SYSTEM	LOCATION ON HOOD
1		ANSUL R102	3.0/3.0	13	FIRE CABINET LEFT	LEFT, HOOD 1

GAS VALVE(S)

FIRE SYSTEM NO	TAG	TYPE	SIZE	SUPPLIED BY
1		MECHANICAL	1.500	CAPTIVEAIR SYSTEMS

FIRE SYSTEM PARTS LIST KEY

FIRE SYSTEM NO	TAG	KEY NUMBER - PART DESCRIPTION	QTY BY FACTORY	QTY BY DIST
1		0 - 0 - 43-15733 AIR CYLINDER ASSEMBLY - AIR CYLINDER AND TUBING FOR MECHANICAL GAS VALVES (ANSUL PART #15733).	1	0
		0 - 0 - 439861 LARGE BLOWOFF CAP, METAL, TO FIT NEW LASER-ETCHED ANSUL NOZZLES, A0024201.	9	0
		0 - 0 - TANK STRAP TANK STRAP - USED FOR ANSUL TANKS.	2	0
		0 - 0 - UCTANKBRACKET TANK BRACKET FOR FIRE SYSTEM TANK INSTALLATION IN UTILITY CABINETS.	2	0
		1 - 1 - AT - 3.0 TANK(H1B) - 3.0 GALLON SS TANK (FOR USE WITH AUTOMAN RELEASE, ACTUATOR, OR SS ENCLDSURE (UL/ULC)) MACOLA # 01-429862.	2	0
		3 - 3 - ANS-DEM REGULATED RELEASE - ANSUL REGULATED MECHANICAL RELEASE/BRACKET ASSEMBLY, DEM, R-102, CARTRIDGE DETECTION INCLUDED, ANSUL PART # 79493.	1	0
		5 - 5 - LIQ-3.0 AGENT - ANSULEX LOW PH WET CHEMICAL AGENT, 3 GALLON (UL) 79372.	0	2
		9 - 9 - 101-30 CARTRIDGE - CARBON DIOXIDE, 101-30, CARTRIDGE (R-102) 19-15851.	0	1
		10 - 10 - TLINK LINK - TEST LINK (1 TEST LINK) ANSUL PART # 24916, MACOLA # 20-24916.	0	1
		11 - 11 - MICRO-SDA MICROSWITCH KIT- INCLUDES 2 SWITCHES AND MOUNTING HARDWARE. SINGLE DUAL ELECTRIC SWITCH, ONE STANDARD SWITCH, ONE ALARM DUTY SWITCH ANSUL PART # 437155, MACOLA # 08-437155.	1	0
		12 - 12 - HOSE HOSE - RUBBER HOSE.	1	0
		14 - 14 - 419336 NOZZLE - 1W NOZZLE, DUCT/APPLIANCE (REPLACES ANSUL PART# 419347, CAS PART# 419336) A0001266.	2	0
		16 - 16 - 419335 NOZZLE - 1N NOZZLE, PLENUM/APPLIANCE (REPLACES ANSUL PART# 419346, CAS PART# 419335) A0001265.	4	0
		19 - 19 - 419338 NOZZLE - 3N NOZZLE, APPLIANCE (REPLACES ANSUL PART# 419349, CAS PART# 419338) A0001268.	1	0
		20 - 20 - 419340 NOZZLE - 245 NOZZLE, APPLIANCE (REPLACES ANSUL PART# 419351, PART# 419340) A0001270.	2	0
		25 - 25 - 418569 NOZZLE ADAPTOR - SWIVEL NOZZLE ADAPTOR (REPLACES CAS PART # 418569) A0001274.	3	0
		26 - 26 - QSA-3/8 QUIK SEAL - 3/8" (UL).	9	0
		27 - 27 - QPSA-1/2 PULLEY SEAL - 1/2" HOOD SEAL (UL) ANSUL PART # 423253, MACOLA # 32-79768.	1	0
		28 - 28 - S-DET DETECTOR - SERIES (SCISSOR LINKAGE) ANSUL PART # 435547/435548 (OLD # 417369/434480); MACOLA # 05-417369.	6	0
		29 - 29 - ANS-360FL FUSIBLE LINK - 360DEG F, R-102 AND PIRANHA, ANSUL PART # 439088.	3	0
	30 - 30 - ANS-500FL FUSIBLE LINK - 500DEG F, R-102 AND PIRANHA, ANSUL PART # 439232.	3	0	
	34 - 34 - RPS-A REMOTE PULL STATION - RED COMPOSITE (WITHOUT WIRE ROPE) 434618 (OLD MACOLA #06-4835).	1	0	
	35 - 35 - PE-LT PULLEY ELBOW - LOW TEMP. PULLEY ELBOW, SET SCREW TYPE ANSUL PART # 415670, MACOLA # 11-415671.	2	0	
	36 - 36 - PE-HT PULLEY ELBOW - HIGH TEMP PULLEY ELBOW, COMPRESSION TYPE, ANSUL PART # 423251, MACOLA # 10-45771.	1	0	

REVISIONS

DESCRIPTION	DATE

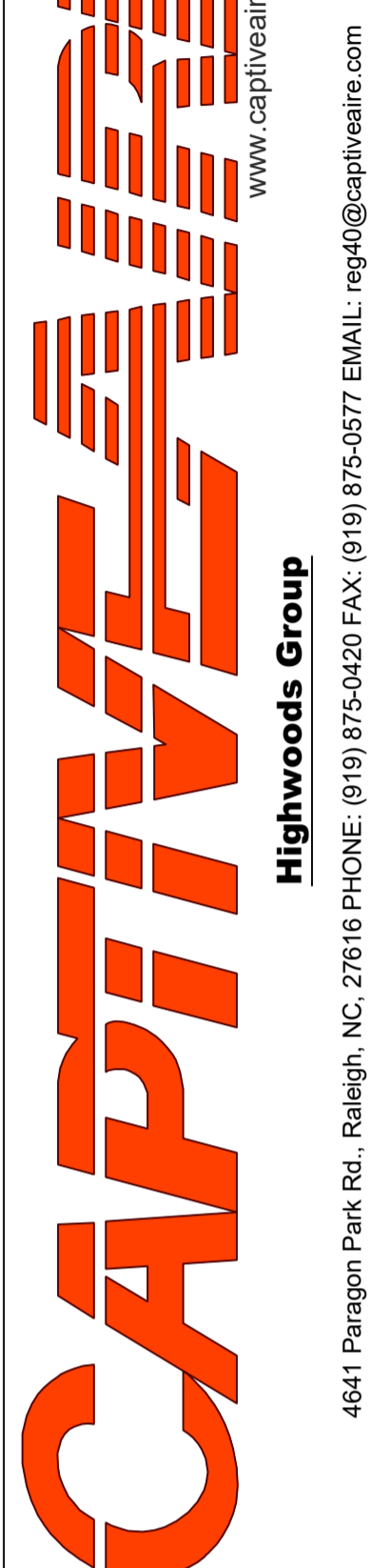
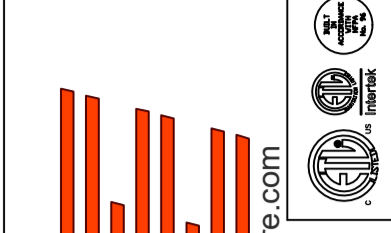

CHIPOTLE RICHMOND CENTRAL #4321
RICHMOND, BC, V6X 0M6

DATE: 3/14/2022
DWG.#: 5211062
DRAWN BY: JMB-40
SCALE: 3/4" = 1'-0"
MASTER DRAWING

SHEET NO.
4

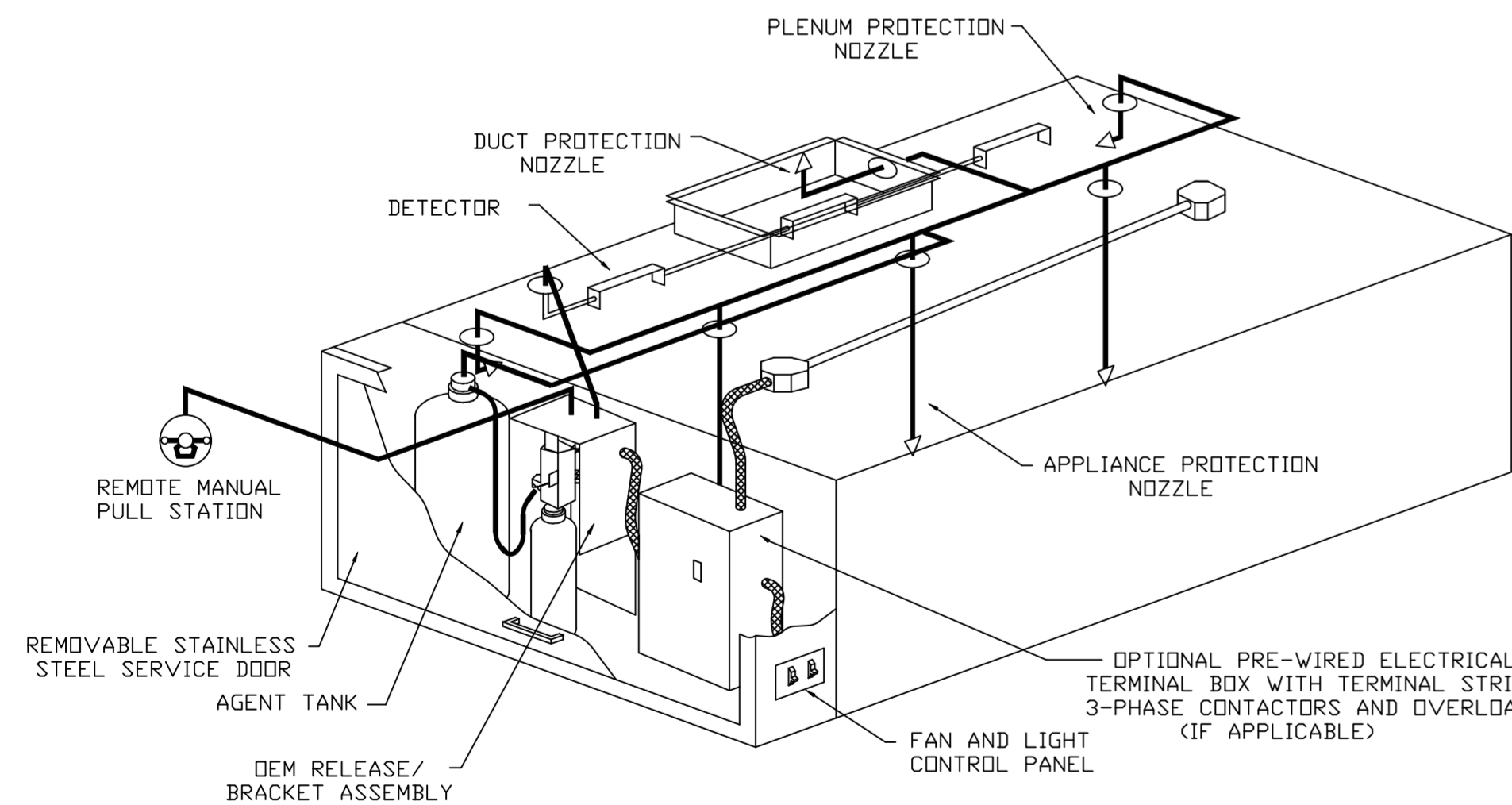
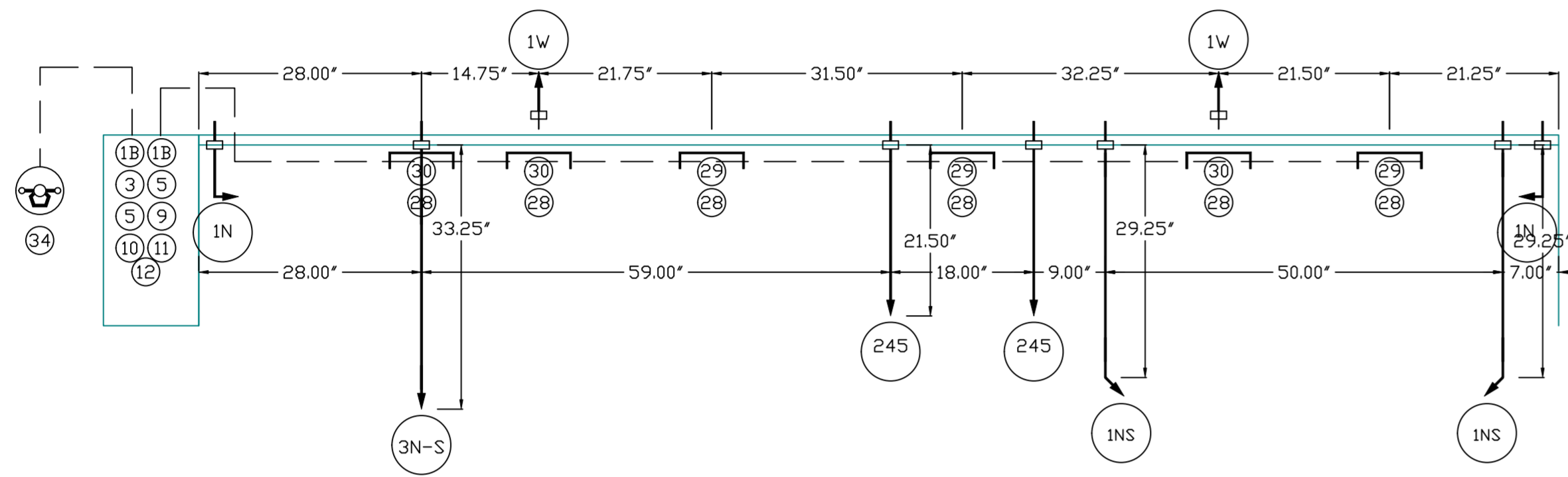
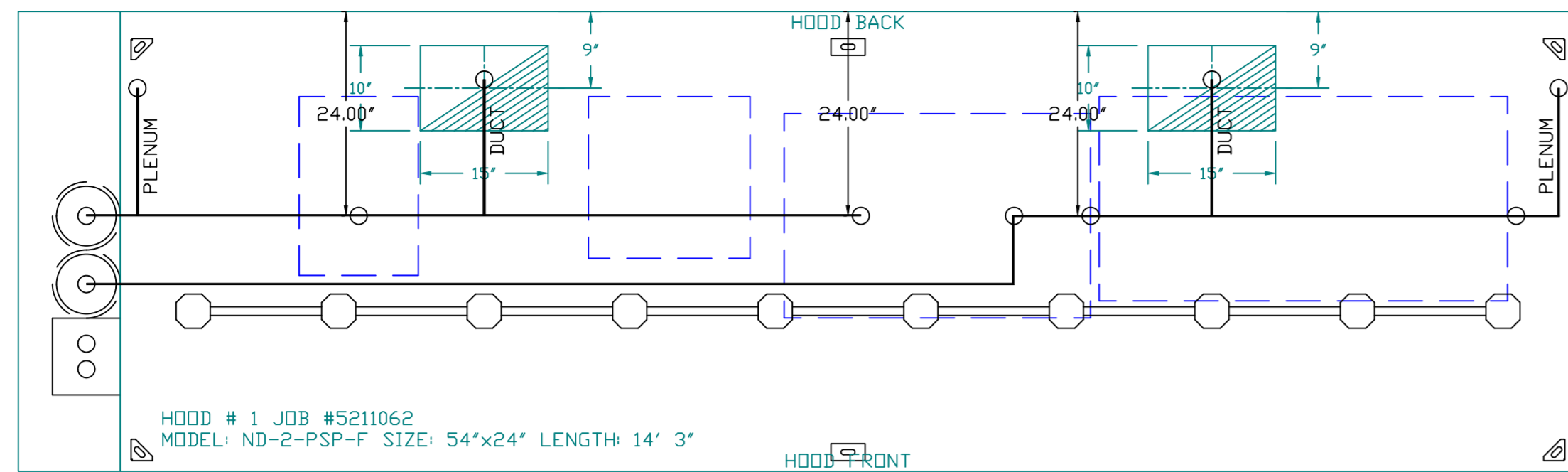

TYPICAL ANSUL R-102 SYSTEM LAYOUT

INCLUDES: FIELD INSTALLATION AND HOOKUP DURING NORMAL BUSINESS HOURS BY CERTIFIED INSTALLERS ONLY IN THE LOCATION NOTED ABOVE. TWO SITE VISITS ONLY (ONE VISIT TO SET PULL STATION & SYSTEM HOOKUP AND ONE VISIT FOR ONE TEST; ADDITIONAL VISITS WILL RESULT IN ADDITIONAL CHARGES). ONE MECHANICAL GAS VALVE PER SYSTEM AT A MAXIMUM SIZE OF 2", PERMIT, AND SYSTEM TEST.
EXCLUDES: UNION LABOR & PREVAILING WAGE (LABOR & WAGES WILL BE ADDED IF APPLICABLE), GAS VALVE INSTALLATION, ELECTRICAL HOOKUP AND CONNECTIONS, HANGING OF FIRE CABINET, SHUNT TRIP, HANDHELD EXTINGUISHER(S), ON-SITE RE-PIPING DUE TO EQUIPMENT LAYOUT CHANGES.

NOTES

- FIELD PIPE DROPS AS SHOWN
- SLEEVING, ELBOWS, TEES, AND NOZZLES SUPPLIED BY CAS.
- RELOCATE NOZZLES IF FLOW PATTERN IS BLOCKED BY SHELVEING, SALAMANDERS, ETC.
- MAXIMUM 9 ELBOWS IN SUPPLY LINE.
- MINIMUM 72 INCHES OF AGENT LINE FROM TANK TO FIRST NOZZLE COVERING A RANGE, FRYER, OR WOK TO REFLECT GENERAL PIPING REQUIREMENTS.
- IF APPLICABLE, PRE-PIPED CHARBROILER DROPS ARE SHIPPED LOOSE.
- FACTORY PIPING EXTENDS A MAXIMUM OF 6' ABOVE THE TOP OF THE HOOD.
- APPLIANCE DIMENSIONS LISTED REPRESENT THE COOKING SURFACE SIZE, NOT THE OVERALL APPLIANCE SIZE.

SPECIFICATIONS

THE RESTAURANT FIRE SUPPRESSION SYSTEM SHALL BE THE PRE-ENGINEERED TYPE WITH A FIXED NOZZLE AGENT DISTRIBUTION NETWORK. IT SHALL BE LISTED WITH UNDERWRITERS LABORATORIES, INC. (UL)

THE SYSTEM SHALL BE CAPABLE OF AUTOMATIC DETECTION AND ACTUATION WITH LOCAL OR REMOTE MANUAL ACTUATION. ACCESSORIES SHALL BE AVAILABLE FOR MECHANICAL OR ELECTRICAL GAS LINE SHUT-OFF APPLICATIONS.

THE EXTINGUISHING AGENT SHALL BE A POTASSIUM CARBONATE, POTASSIUM ACETATE-BASED FORMULATION DESIGNED FOR FLAME KNOCKDOWN AND SECUREMENT OF GREASE RELATED FIRES. IT SHALL BE AVAILABLE IN PLASTIC CONTAINERS WITH INSTRUCTIONS FOR LIQUID AGENT HANDLING AND USAGE.

THE REGULATED RELEASE MECHANISM SHALL BE COMPATIBLE WITH A FUSIBLE LINK DETECTION SYSTEM. THE FUSIBLE LINK SHALL BE SELECTED AND INSTALLED ACCORDING TO THE OPERATING TEMPERATURE IN THE VENTILATING SYSTEM. THE FUSIBLE LINK SHALL BE SUPPORTED BY A DETECTOR BRACKET/ LINKAGE ASSEMBLY.

NOTES

- FIELD PIPE DROPS AS SHOWN
- SLEEVING, ELBOWS, TEES, AND NOZZLES SUPPLIED BY CAS.
- RELOCATE NOZZLES IF FLOW PATTERN IS BLOCKED BY SHELVEING, SALAMANDERS, ETC.
- MAXIMUM 9 ELBOWS IN SUPPLY LINE.
- MINIMUM 72 INCHES OF AGENT LINE FROM TANK TO FIRST NOZZLE COVERING A RANGE, FRYER, OR WOK TO REFLECT GENERAL PIPING REQUIREMENTS.
- IF APPLICABLE, PRE-PIPED CHARBROILER DROPS ARE SHIPPED LOOSE.
- FACTORY PIPING EXTENDS A MAXIMUM OF 6' ABOVE THE TOP OF THE HOOD.
- APPLIANCE DIMENSIONS LISTED REPRESENT THE COOKING SURFACE SIZE, NOT THE OVERALL APPLIANCE SIZE.
- THIS FIRE SYSTEM COMPLIES WITH U.L. 300 REQUIREMENTS.

JOB #: 5211062

JOB NAME: CHIPOTLE RICHMOND #4321

SYSTEM SIZE: ANSUL-3.0/3.0 TOTAL FP REQUIRED: 13.

HOOD # 1 14' 3.00" LONG x 54" WIDE x 24" HIGH.

RISER # 1 SIZE: 10" x 15".

RISER # 2 SIZE: 10" x 15".

HOOD # 1 METAL BLOW-OFF CAPS INCLUDED.

LEGEND - FIRE CABINET ANSUL SYSTEM

- 1A 1.5 GALLON TANK.
- 1B 3 GALLON TANK.
- 2 DEM AUTOMAN RELEASE.
- 3 DEM REGULATED RELEASE.
- 4 DEM REGULATED ACTUATOR.
- 5 ANSULEX LIQUID AGENT (3 GAL.).
- 6 ANSULEX LIQUID AGENT (1.5 GAL.).
- 7 CARTRIDGE (101-20).
- 8 CARTRIDGE (101-10).
- 9 CARTRIDGE (101-30).
- 9A CARTRIDGE (LT-A-101-30).
- 9B DOUBLE TANK CARTRIDGE.
- 10 TEST LINK.
- 11 DOUBLE MICROSWITCH.
- 12 HOSE ASSEMBLY.
- 1100 DUCT NOZZLE (430913).
- 2W DUCT NOZZLE (419337).
- 1W NOZZLE ASSEMBLY (419336).
- 1F NOZZLE ASSEMBLY (419333).
- 1N NOZZLE ASSEMBLY (419335).
- 1/2N NOZZLE ASSEMBLY (419334).
- 3N NOZZLE ASSEMBLY (419338).
- 245 NOZZLE ASSEMBLY (419340).
- 230 NOZZLE ASSEMBLY (419339).
- 2120 NOZZLE ASSEMBLY (419343).
- 290 NOZZLE ASSEMBLY (419342).
- 260 NOZZLE ASSEMBLY (419341).
- 28 DETECTOR BRACKET.
- 29 LOW TEMP FUSIBLE LINK.
- 30 HIGH TEMP FUSIBLE LINK.
- MGV MECHANICAL GAS VALVE.
- EGV ELECTRICAL GAS VALVE.
- 34 REMOTE MANUAL PULL STATION.
- S SWIVEL ADAPTOR.

JOB #: 5211062.

JOB NAME: CHIPOTLE RICHMOND CENTRAL #4321.

SYSTEM SIZE: ANSUL-3.0/3.0 TOTAL FP REQUIRED: 13.

HOOD # 1 14' 3.00" LONG x 54" WIDE x 24" HIGH.

RISER # 1 SIZE: 10" x 15".

RISER # 2 SIZE: 10" x 15".

REVISIONS	
DESCRIPTION	DATE

Highwoods Group

www.captivefire.com

4641 Paragon Park Rd., Raleigh, NC, 27616 PHONE: (919) 875-0420 FAX: (919) 875-0577 EMAIL: reg10@captivefire.com

CHIPOTLE RICHMOND CENTRAL #4321

RICHMOND, BC, V6X 0M6

DATE: 3/14/2022

DWG.#: 5211062

DRAWN BY: JMB-40

SCALE: 3/4" = 1'-0"

MASTER DRAWING

SHEET NO. 5

GAS VALVES AND STRAINERS																
GAS VALVE SIZING							GAS VALVE DIMENSIONS					INSTALLATION	PART NUMBERS			
TYPE	SIZE	VOLTAGE	MIN. INLET PRESSURE	MAX. INLET PRESSURE	FLOW AT 1 IN.W.C. DROP NATURAL GAS	FLOW AT 1 IN.W.C. DROP PROPANE	DIM "A"	DIM "B"	DIM "C"	DIM "D"	DIM "F"	DIM "G"	MOUNTING ORIENTATION	GAS VALVE PART NUMBER	STRAINER PART NUMBER	GAS VALVE/STRAINER KIT
GAS VALVE FOR FS#1 → MECHANICAL	1-1/2"	N/A	0 PSI (0 IN.W.C.)	10 PSI (277 IN.W.C.)	2,630,000 BTU/HR	1,706,569 BTU/HR	6-3/8"	4-7/8"	5-3/4"	6-3/16"	12-5/8"	11-3/8"	HORIZONTAL	27-55607	4417K67	MGVA1-1/2

ALL GAS VALVES/STRAINERS

PROPER CLEARANCE MUST BE PROVIDED IN ORDER TO SERVICE THE STRAINERS A MINIMUM OF 4" CLEARANCE DISTANCE MUST BE PROVIDED AT THE BASE OF THE STRAINER CUSTOMER MUST VERIFY BTU CONSUMPTION AS WELL AS PRESSURE RATING SPECIFIC GRAVITY OF NATURAL GAS = 0.64, SPECIFIC GRAVITY OF LP = 1.52.

CALCULATIONS

TO CALCULATE GAS FLOW FOR OTHER THAN 1 IN.W.C. PRESSURE DROP
 NEW BTU/HR = (BTU/HR AT 1 IN.W.C. PRESSURE DROP) X NEW PRESSURE DROP^{0.5}
 TO CALCULATE GAS FLOW FOR OTHER THAN 0.64 SPECIFIC GRAVITY
 NEW BTU/HR = (BTU/HR AT 0.64) X (0.64 / NEW SPECIFIC GRAVITY)^{0.5}

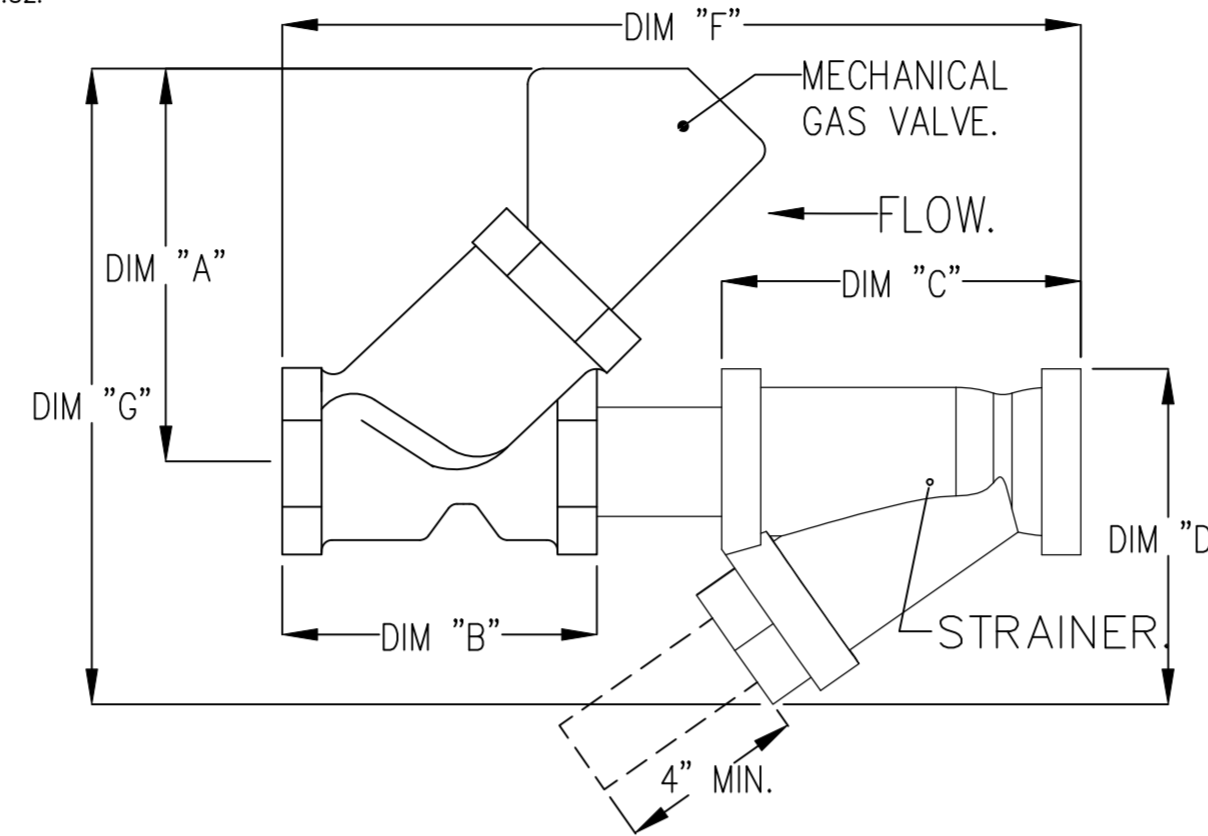

REVISIONS

DESCRIPTION	DATE

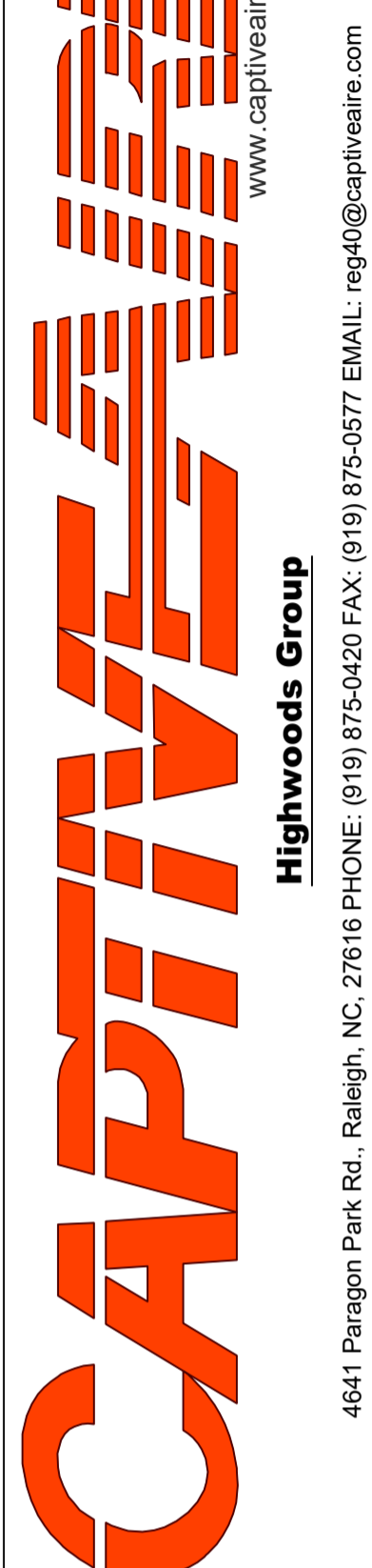
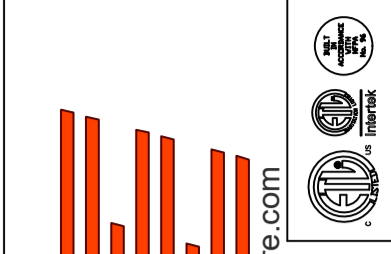

www.captiveair.com
 4641 Paragon Park Rd., Raleigh, NC, 27616 PHONE: (919) 875-0420 FAX: (919) 875-0577 EMAIL: reg40@captiveair.com

CHIPOTLE RICHMOND CENTRAL #4321
 RICHMOND, BC, V6X 0M6

DATE: 3/14/2022

DWG.#: 5211062

DRAWN BY: JMB-40

SCALE: 3/4" = 1'-0"

MASTER DRAWING

SHEET NO.
6

EXHAUST FAN INFORMATION - JOB#5211062

FAN UNIT NO	TAG	QTY	FAN UNIT MODEL #	MANUFACTURER	CFM	ESP	RPM	MOTOR ENCL	HP	BHP	PHASE	VOLT	FLA	DISCHARGE VELOCITY	WEIGHT (LBS)	SDNES
1	EF-1	1	DU200HFA	CAPTIVEAIRE	3200	2.000	1336	TEFC,PREMIUM	5.000	2.3810	3	575	5.1	779 FPM	240	26
2	EF-2	1	DR12HFA	CAPTIVEAIRE	250	0.750	1471	TEAD-ECM	0.250	0.1410	1	115	2.9		49	9.5

MUA FAN INFORMATION - JOB#5211062

FAN UNIT NO	TAG	QTY	FAN UNIT MODEL #	BLOWER	HOUSING	MIN CFM	DESIGN CFM	ESP	RPM	MOTOR ENCL	HP	BHP	PHASE	VOLT	FLA	MCA	MOCP	WEIGHT (LBS)	SDNES
3	MAU-1	1	A1-D.250-15D	15MF-1-MDD	A1-D.250	1000	1950	0.450	2010	DDP,PREMIUM	2.000	1.3310	3	575	2.1	2.7A	15A	517	21

GAS FIRED MAKE-UP AIR UNIT(S)

FAN UNIT NO	TAG	INPUT BTUs	OUTPUT BTUs	TEMP RISE	REQUIRED INPUT GAS PRESSURE	GAS TYPE	BURNER EFFICIENCY(%)
3	MAU-1	223711	205814	110°F	7 IN. W.C. - 14 IN. W.C.	NATURAL	92

FAN OPTIONS

FAN UNIT NO	TAG	QTY	DESCRIPTION
1	EF-1	1	GREASE BOX
		1	REMOVE HINGE KIT LABEL FROM THE FAN BASE
		1	LOAD REACTOR MOUNTED IN FAN
		1	2 YEAR PARTS WARRANTY
2	EF-2	1	12-BDD DAMPER
		1	ECM WIRING PACKAGE - MANUAL DR 0-10VDC REFERENCE SPEED CONTROL (TELCO MOTOR), CCW ROTATION
3	MAU-1	1	2 YEAR PARTS WARRANTY
		1	INLET PRESSURE GAUGE, 0-35"
		1	MANIFOLD PRESSURE GAUGE, -5 TO 15" WC
		1	MOTORIZED BACKDRAFT DAMPER FOR A1-D HOUSING - MEETS AMCA CLASS 1A RATING
		1	LOW FIRE START
		1	EXHAUST CONTACTOR BEFORE AIRFLOW SWITCH - FIELD WIRED
		1	UPSTREAM PILOT FOR SIZES 1-3
		1	FREEZESTAT (10)
		1	LOAD REACTOR MOUNTED IN FAN
		1	SEPARATE 120V WIRING PACKAGE (REQUIRED AND USED ONLY FOR DCV OR PREWIRE WITH VFD) - THREE PHASE ONLY
		1	UNIT MOUNTED VFD FOR USE WITH ECM03
		1	SIZE 1 TEMPERED COMMERCIAL DOWN DISCHARGE FOR DIRECT DRIVE AHUS
		1	2 YEAR PARTS WARRANTY

FAN ACCESSORIES

FAN UNIT NO	TAG	EXHAUST				SUPPLY			
		GREASE CUP	GRAVITY DAMPER	WALL MOUNT	SIDE DISCHARGE	GRAVITY DAMPER	MOTORIZED DAMPER	WALL MOUNT	
1	EF-1	YES							
2	EF-2		YES						
3	MAU-1						YES		

CURB ASSEMBLIES

NO	ON FAN	TAG	WEIGHT	ITEM	SIZE
1	# 1	EF-1	37 LBS	CURB	26.500"W X 26.500"L X 20.000"H ALONG LENGTH, RIGHT VENTED.
2	# 2	EF-2	31 LBS	CURB	17.500"W X 17.500"L X 26.000"H ALONG LENGTH, RIGHT.
3	# 3	MAU-1	65 LBS	CURB	21.000"W X 71.000"L X 20.000"H ALONG WIDTH, RIGHT INSULATED.

FAN #1 DU200HFA - EXHAUST FAN (EF-1)

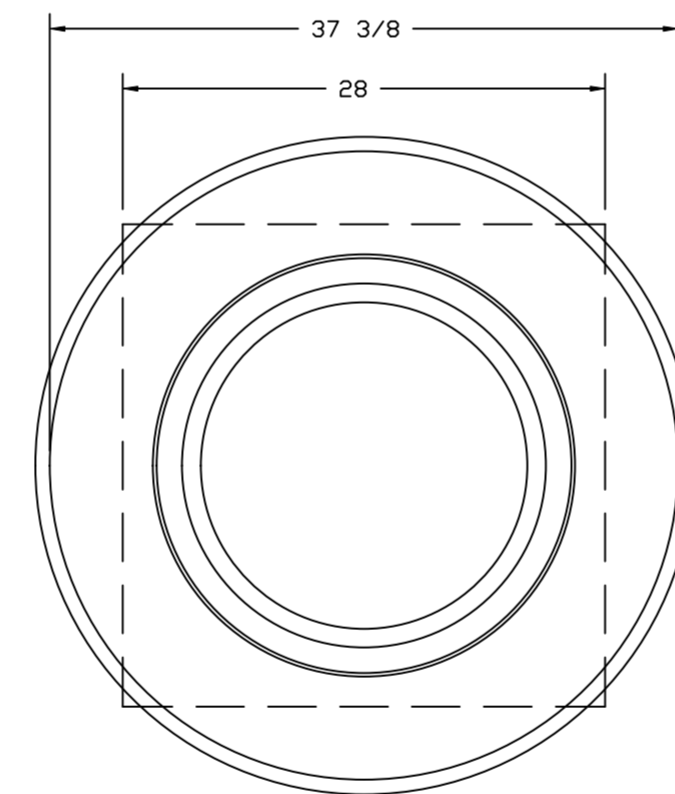
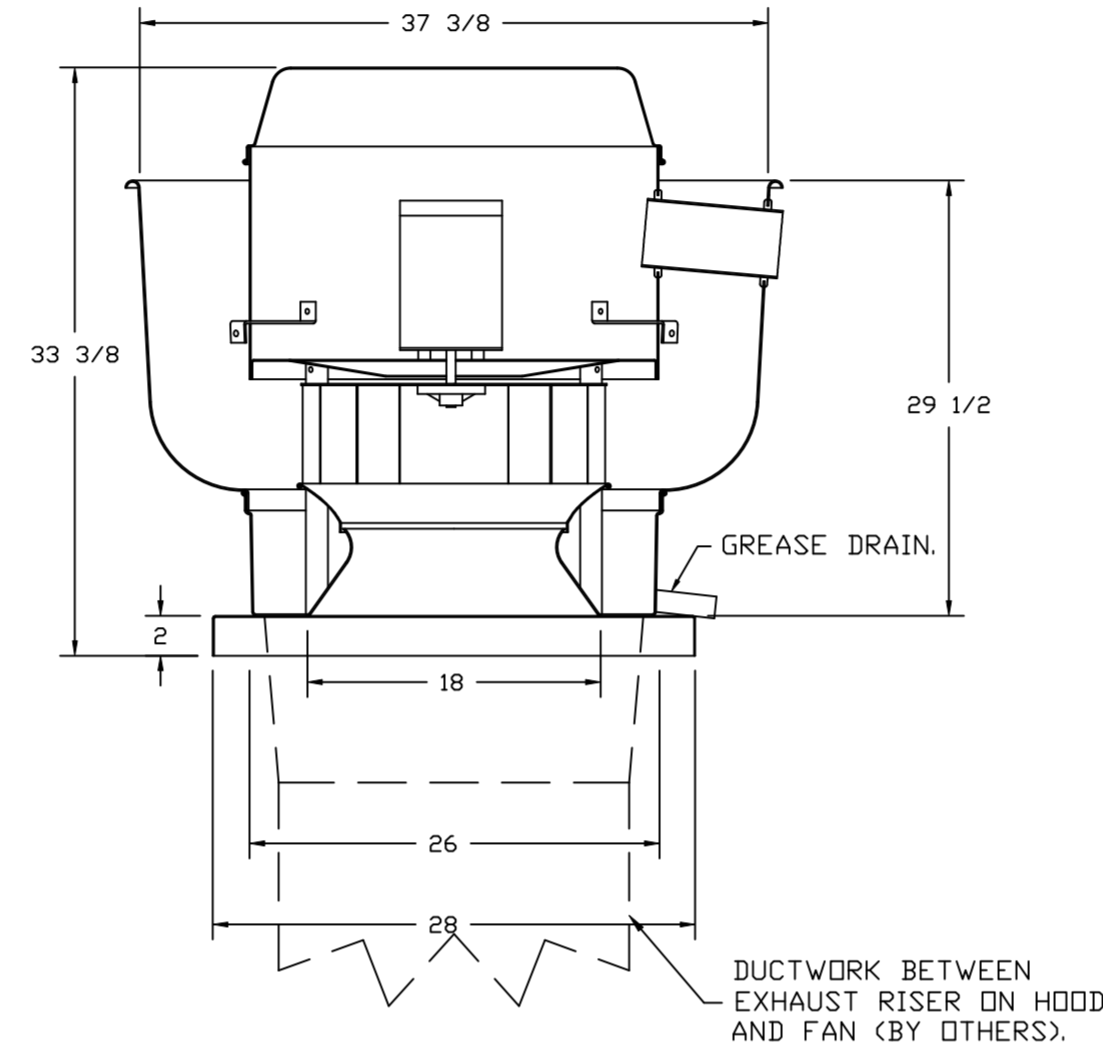

TOP VIEW

FEATURES:

- DIRECT DRIVE CONSTRUCTION (NO BELTS/PULLEYS).
- ROOF MOUNTED FANS.
- RESTAURANT MODEL.
- UL705 AND UL762 AND ULC-S645
- VARIABLE SPEED CONTROL.
- INTERNAL WIRING.
- THERMAL OVERLOAD PROTECTION (SINGLE PHASE).
- HIGH HEAT OPERATION 300°F (149°C).
- GREASE CLASSIFICATION TESTING.
- NEMA 3R SAFETY DISCONNECT SWITCH.

NORMAL TEMPERATURE TEST

EXHAUST FAN MUST OPERATE CONTINUOUSLY WHILE EXHAUSTING AIR AT 300°F (149°C) UNTIL ALL FAN PARTS HAVE REACHED THERMAL EQUILIBRIUM, AND WITHOUT ANY DETERIORATING EFFECTS TO THE FAN WHICH WOULD CAUSE UNSAFE OPERATION.

ABNORMAL FLARE-UP TEST

EXHAUST FAN MUST OPERATE CONTINUOUSLY WHILE EXHAUSTING BURNING GREASE VAPORS AT 600°F (316°C) FOR A PERIOD OF 15 MINUTES WITHOUT THE FAN BECOMING DAMAGED TO ANY EXTENT THAT COULD CAUSE AN UNSAFE CONDITION.

OPTIONS

- GREASE BOX.
- REMOVE HINGE KIT LABEL FROM THE FAN BASE.
- LOAD REACTOR MOUNTED IN FAN.
- 2 YEAR PARTS WARRANTY.

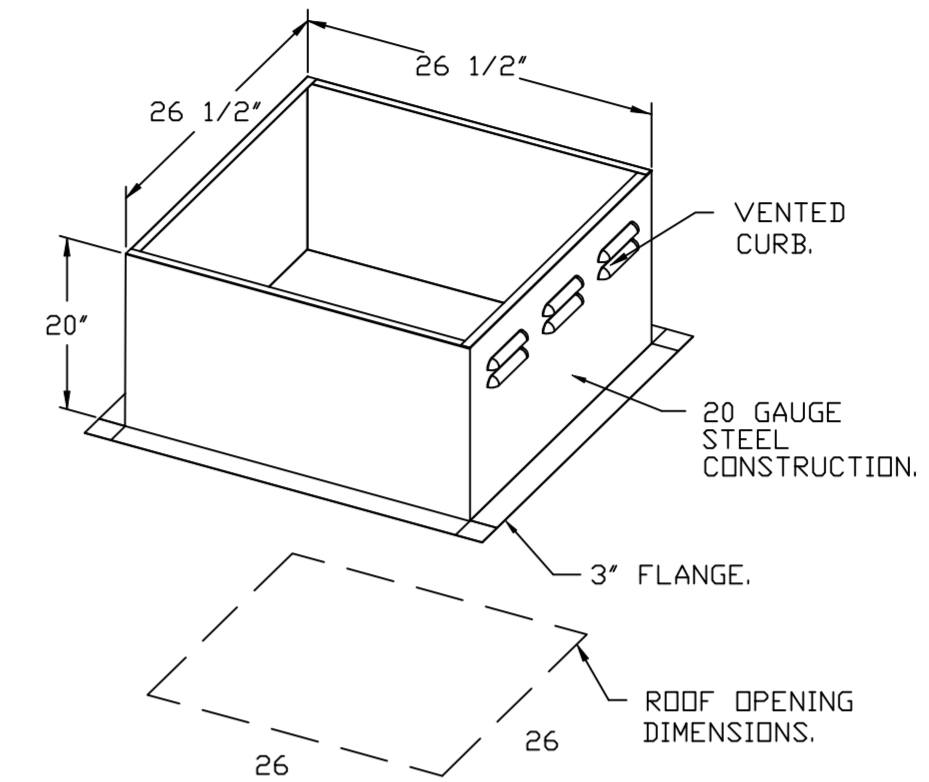

PITCHED CURBS ARE AVAILABLE FOR PITCHED ROOFS.

SPECIFY PITCH:
EXAMPLE: 7/12 PITCH = 30° SLOPE.

REVISIONS

DESCRIPTION	DATE

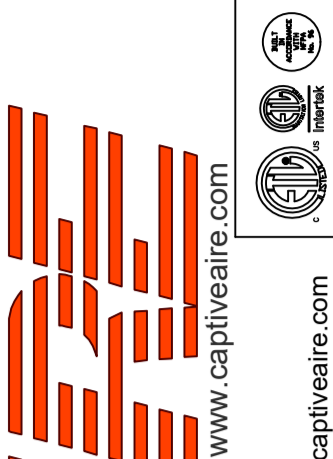

CHIPOTLE RICHMOND CENTRAL #4321
RICHMOND, BC, V6X 0M6

DATE: 3/14/2022

DWG.#: 5211062

DRAWN BY: JMB-40

SCALE: 3/4" = 1'-0"

MASTER DRAWING

SHEET NO.

FAN #2 DR12HFA - EXHAUST FAN (CF-2)

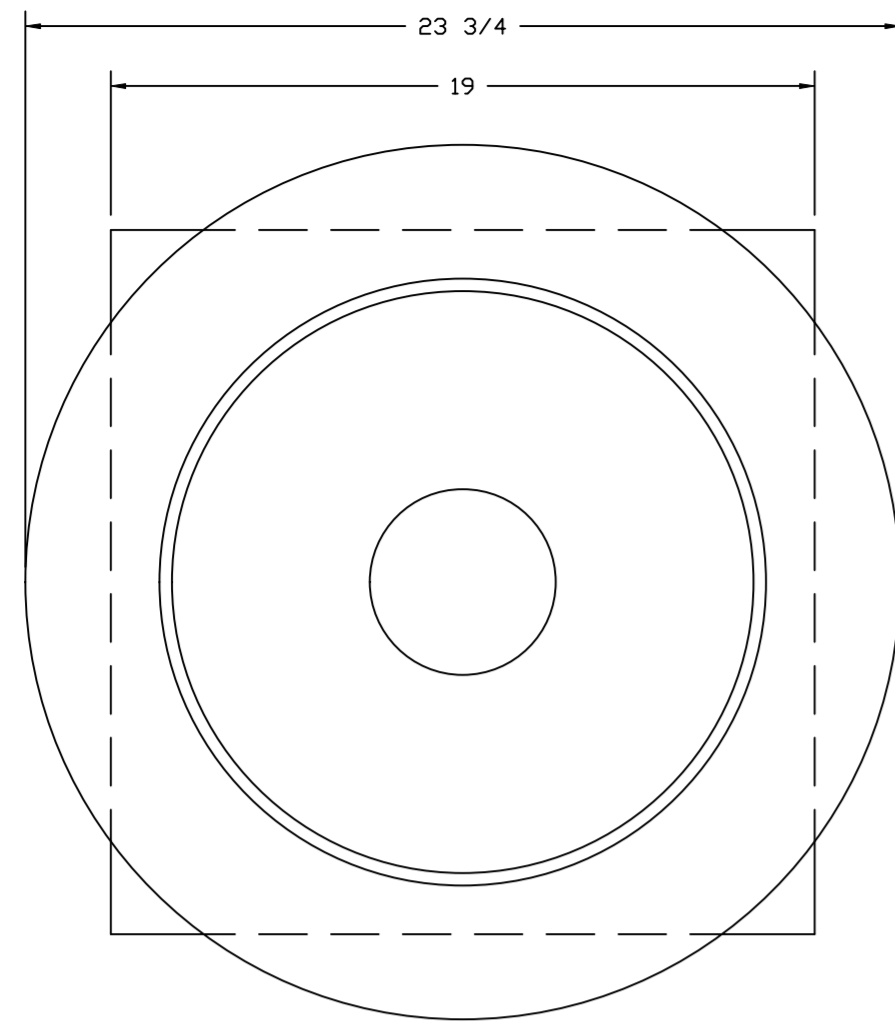

TOP VIEW

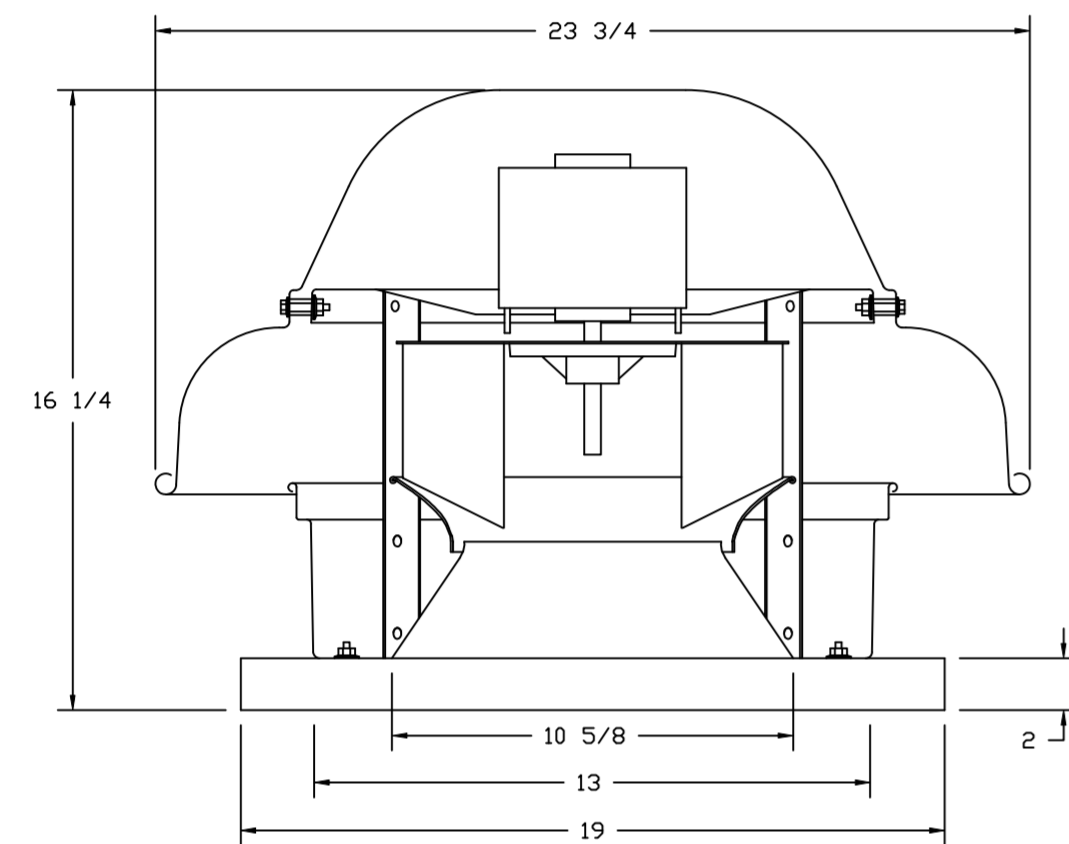

FEATURES:

- DIRECT DRIVE CONSTRUCTION (NO BELTS/PULLEYS).
- ROOF MOUNTED FANS.
- UL705.
- SAFETY DISCONNECT.
- STANDARD BIRD SCREEN.
- SPEED CONTROL.

OPTIONS:

- 1 12-BDD DAMPER.
- EDM WIRING PACKAGE - MANUAL OR 0-10VDC REFERENCE SPEED CONTROL (TELCO MOTOR), CCW ROTATION.
- 2 YEAR PARTS WARRANTY.

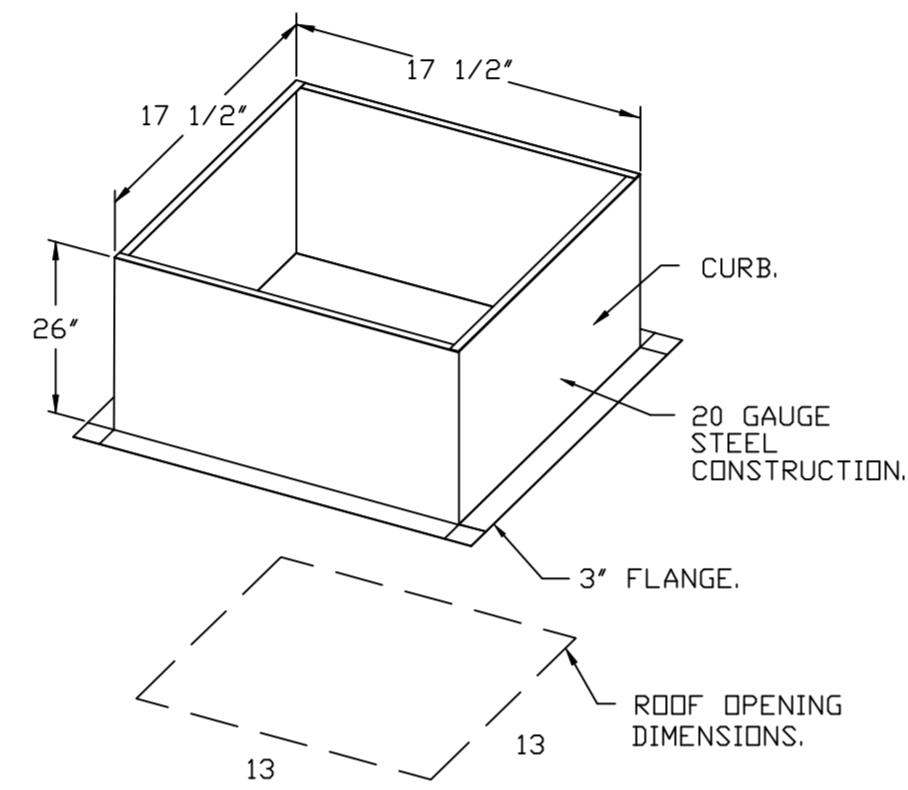

PITCHED CURBS ARE AVAILABLE FOR PITCHED ROOFS.
 SPECIFY PITCH:
 EXAMPLE: 7/12 PITCH = 30° SLOPE.

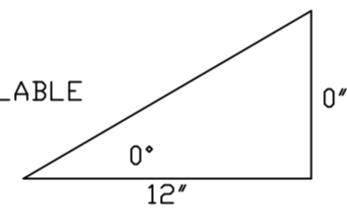

BACKDRAFT DAMPER INSTALLATION

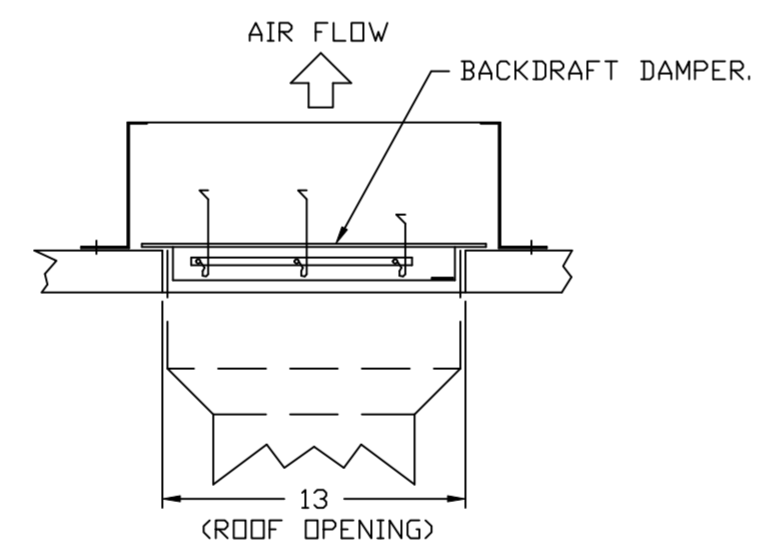

REVISIONS

DESCRIPTION	DATE:

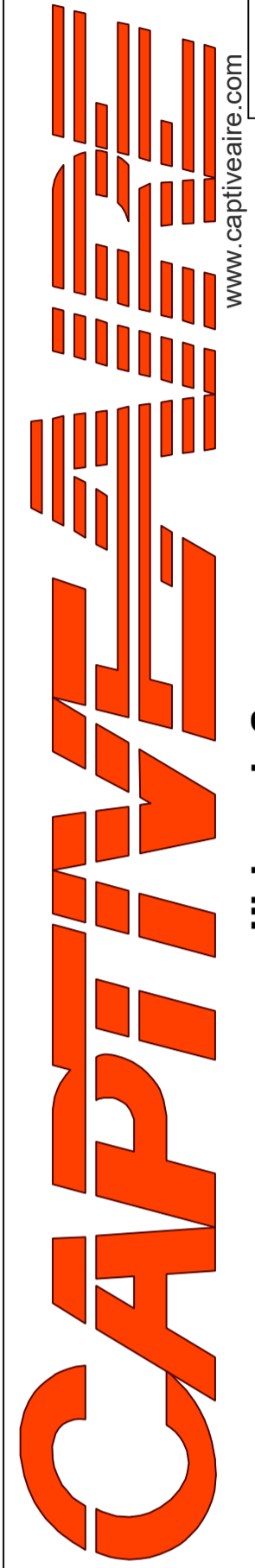
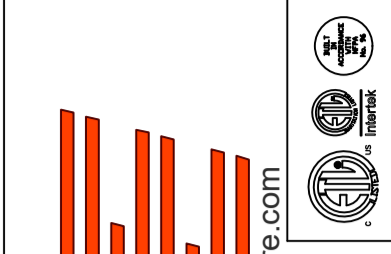

www.captiveair.com

Highwoods Group

4641 Paragon Park Rd., Raleigh, NC, 27616 PHONE: (919) 875-0420 FAX: (919) 875-0577 EMAIL: reg40@captiveair.com

CHIPOTLE RICHMOND CENTRAL #4321
 RICHMOND, BC, V6X 0M6

DATE: 3/14/2022

DWG.#: 5211062

DRAWN BY: JMB-40

SCALE: 3/4" = 1'-0"

MASTER DRAWING

SHEET NO. 8

- FAN #3 AI-D250-1SD - HEATER (MAU-1)
1. DIRECT GAS FIRED HEATED MAKE UP AIR UNIT WITH 15" MIXED FLOW DIRECT DRIVE FAN.
 2. INTAKE HOOD WITH EZ FILTERS.
 3. DOWN DISCHARGE - AIR FLOW RIGHT -> LEFT.
 4. GAS PRESSURE GAUGE, 0-35", 2.5" DIAMETER, 1/4" THREAD SIZE.
 5. GAS PRESSURE GAUGE, -5 TO +15 INCHES WC, 2.5" DIAMETER, 1/4" THREAD SIZE.
 6. MOTORIZED BACK DRAFT DAMPER 16" X 18" FOR SIZE 1 STANDARD & MODULAR HEATER UNITS W/EXTENDED SHAFT, STANDARD GALVANIZED CONSTRUCTION, 3/4" REAR FLANGE, LOW LEAKAGE, TFB20S ACTUATOR INCLUDED.
 7. LOW FIRE START, ALLOWS THE BURNER CIRCUIT TO ENERGIZE WHEN THE MODULATION CONTROL IS IN A LOW FIRE POSITION.
 8. FIELD WIRED EXHAUST CONTACTOR BEFORE AIRFLOW SWITCH. RATED 23 AMPS. STARTS UP TO (2) SINGLE PHASE MOTORS. 2HP MAX. 115V, 3HP MAX. 240V. STARTS ONE THREE PHASE MOTOR. 5HP MAX. 208V, 7.5HP MAX. 230V, 15HP MAX. 460V. OVERLOAD NOT INCLUDED.
 9. PILOT LOCATED UPSTREAM OF FIRST REDUNDANT SOLENOID VALVE OF SIZE 1-3 MAX GAS PRESSURE OF 14" WC.
 10. FREEZE STAT WITH 10" SENSOR. FACTORY SET AT 35°F AND 10 MINUTES.
 11. MOUNT LOAD REACTOR IN FAN.
 12. SEPARATE 120VAC WIRING PACKAGE FOR MAKE-UP AIR UNITS. OPTION MUST BE SELECTED WHEN MOUNTING VFD IN PREWIRE PANEL OR WITH DCV PACKAGE. PROVIDES SEPARATE 120VAC INPUT TO SUPPLY FAN. THIS 120V SIGNAL MUST BE RUN BY ELECTRICIAN FROM DCV TO MUA SWITCH.
 13. UNIT MOUNTED VFD FOR USE WITH ECPM03.
 14. DOWN DISCHARGE CONSTRUCTION FOR SIZE 1 DIRECT DRIVE AHUS.
 15. HINGED DOUBLE WALL INSULATED DOOR ASSEMBLY (BURNER/BLOWER SECTION).
 16. 2 YEAR PARTS WARRANTY.

NOTE: SUPPLY DUCT MUST BE INSTALLED TO MEET SMACNA STANDARDS. A MINIMUM STRAIGHT DUCT LENGTH MUST BE MAINTAINED DOWNSTREAM OF UNIT DISCHARGE AS OUTLINED IN AMCA PUBLICATION 201. WHEN USING RECTANGULAR DUCTWORK, ELBOWS MUST BE RADIUS THROAT, RADIUS BACK WITH TURNING VANES. FLEXIBLE DUCTWORK AND SQUARE THROAT/SQUARE BACK ELBOWS SHOULD NOT BE USED. ANY TRANSITION AND/OR TURNS IN THE DUCTWORK WILL CAUSE SYSTEM EFFECT. SYSTEM EFFECT WILL DRASTICALLY INCREASE STATIC PRESSURE AND REDUCE AIRFLOW. DO NOT RELY ON UNIT TO SUPPORT DUCT IN ANY WAY. FAILURE TO PROPERLY SIZE DUCTWORK MAY CAUSE SYSTEM EFFECTS AND REDUCE PERFORMANCE OF THE EQUIPMENT. SUGGESTED STRAIGHT DUCT SIZE IS 14" X 14".

SUPPLY SIDE HEATER INFORMATION:

WINTER TEMPERATURE = 25°F. TEMP. RISE = 110°F.
 BTUs CALCULATED OFF ACTUAL AIR DENSITY.
 OUTPUT BTUs AT ALTITUDE OF 0.0 FT. = 206038.
 INPUT BTUs AT ALTITUDE OF 0.0 FT. = 223954.
 OUTPUT BTUs AT ALTITUDE OF 30 FT. = 205814.
 INPUT BTUs AT ALTITUDE OF 30 FT. = 223711.

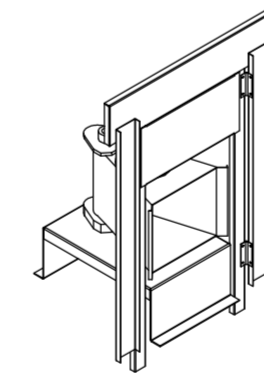
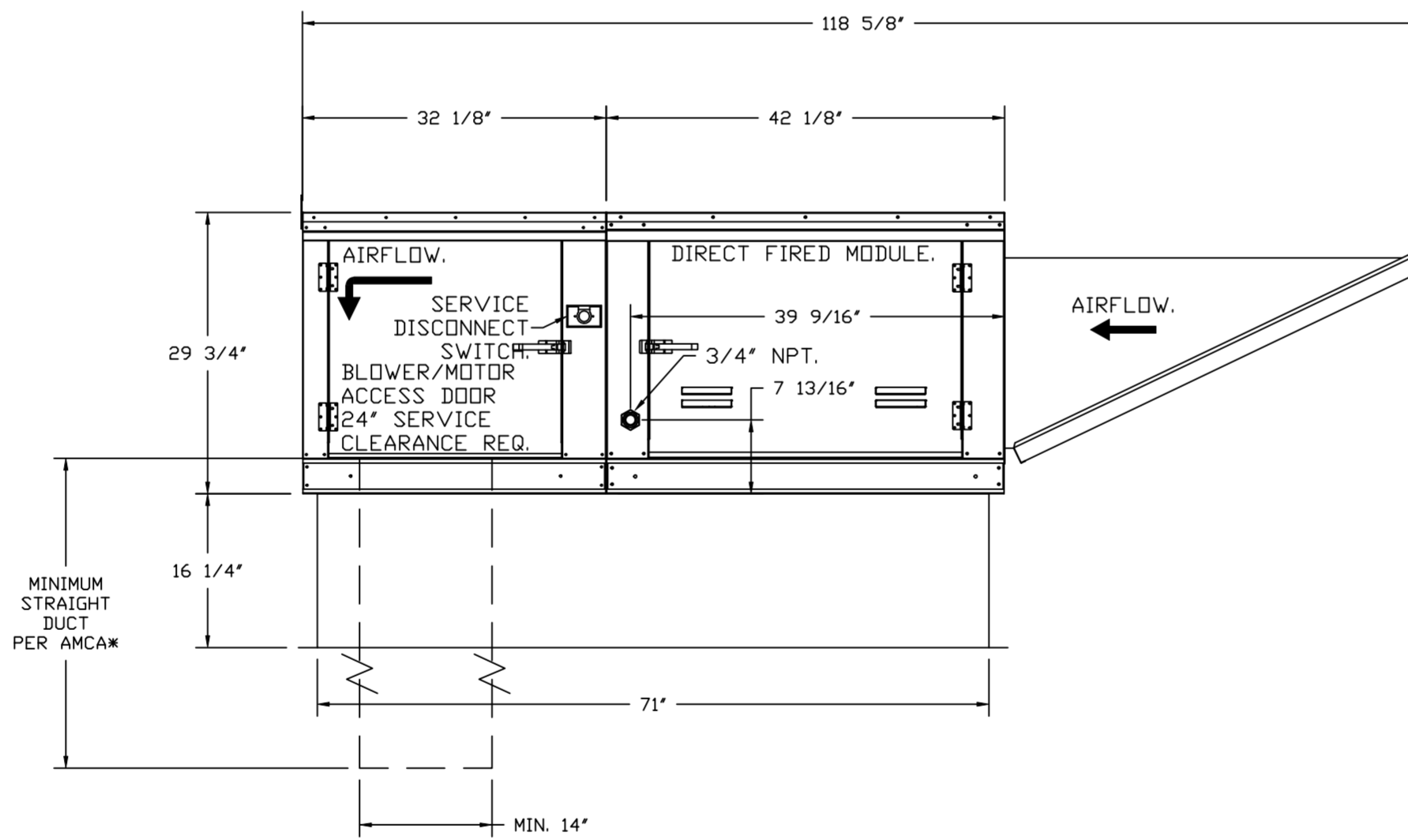
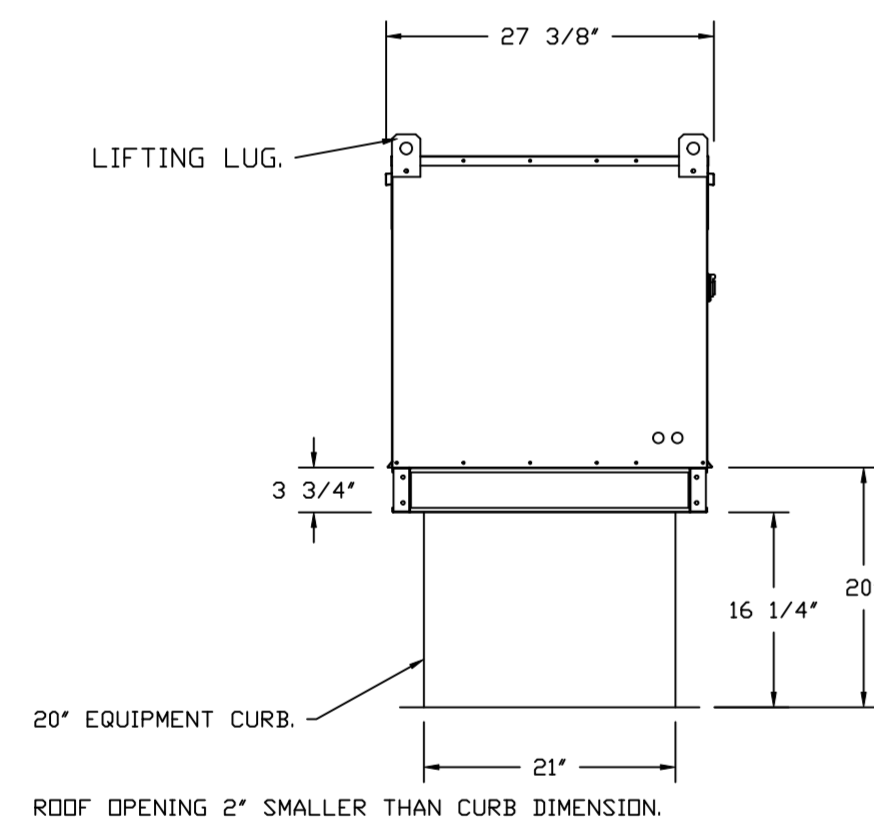
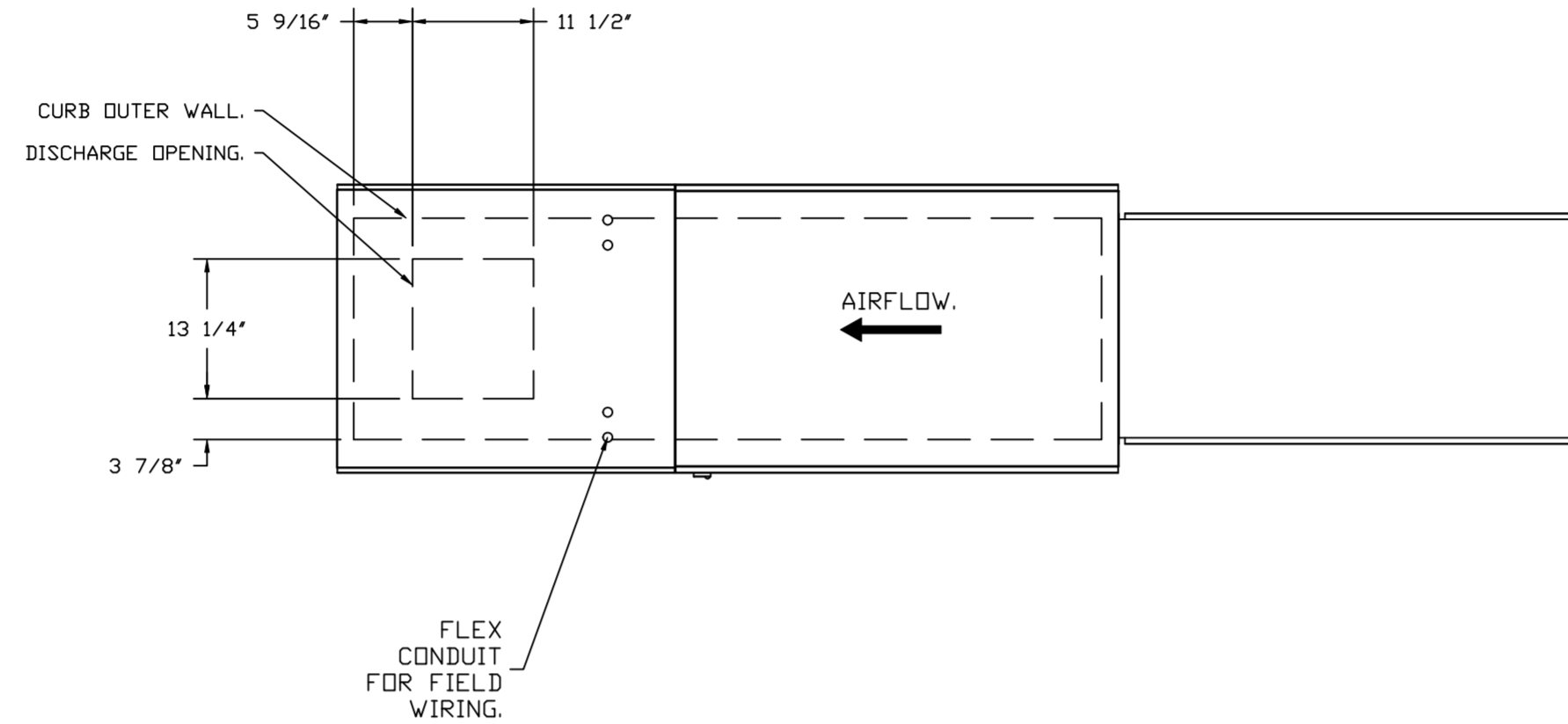

DIRECT FIRED (DF) PROFILE PLATE ASSEMBLY

DIRECT FIRED (DF) PROFILE PLATE SPECIFICATIONS:

DESCRIPTION:
 DIRECT FIRED BURNERS SHALL HAVE PATENTED (US PATENT NO. US6629523B2), SELF-ADJUSTING PROFILE PLATES DESIGNED TO ENSURE PROPER AIR VELOCITY AND PRESSURE DROP ACROSS THE BURNER. PROFILE PLATES SHALL ALLOW BURNERS TO ACHIEVE CLEAN COMBUSTION BY LIMITING BY-PRODUCT LEVELS TO A MAXIMUM OF 50PPM OF CARBON MONOXIDE (CO), AND 0.5PPM OF NITROGEN DIOXIDE (NO2). DIRECT FIRED UNITS SHALL BE CONFIGURED WITH THE BLOWER MOUNTED DOWNSTREAM OF THE BURNER. THIS ARRANGEMENT WILL ENSURE A CONSISTENT AIRFLOW, REGARDLESS OF INLET AIR TEMPERATURE.

APPLICATION:
 SPRING-LOADED BURNER PROFILE PLATES ARE ENGINEERED TO AUTOMATICALLY REACT TO THE MOMENTUM OF A FRESH AIR STREAM, WITHOUT THE NEED FOR ANY MOTORS OR ACTUATORS TO MECHANICALLY ADJUST THEM. WITH THIS FEATURE, ALL DF UNITS ARE DESIGNED FOR DEMAND CONTROL VENTILATION (DCV) REQUIREMENTS.

CERTIFICATIONS:
 ALL PROFILE PLATE ASSEMBLIES SHALL BE INCLUDED IN THE DF UNIT'S ETL LISTING AND COMPLY WITH COMBINED SAFETY STANDARDS ANSI Z83.4 AND CSA 3.7 (NON-RECIRCULATING DF HEATERS) AND ANSI Z83.18 (RECIRCULATING DF HEATERS).

GENERAL CONSTRUCTION:
 -PROFILE PLATES SHALL BE FORMED FROM G90 GALVANIZED STEEL.
 -PROFILE PLATES SHALL VARY IN SIZE PER UNIT.
 -PROFILE PLATES SHALL BE MOUNTED ALONG THE SAME PLANE AS THE DISCHARGE OF THE BURNER.
 -DESIGN SHALL INCORPORATE PROPERLY TORQUED PERMANENTLY MOUNTED SPRING HINGES.
 -SPRING HINGES SHALL BE MADE FROM PLATED STEEL.

REVISIONS	
DESCRIPTION	DATE

www.captiveair.com
 Highwoods Group
 4641 Paragon Park Rd., Raleigh, NC, 27616 PHONE: (919) 875-0420 FAX: (919) 875-0577 EMAIL: reg@captivair.com

CHIPOTLE RICHMOND CENTRAL #4321
 RICHMOND, BC, V6X 0M6

DATE: 3/14/2022

DWG.#:
5211062

DRAWN BY: JMB-40

SCALE:
3/4" = 1'-0"

MASTER DRAWING

SHEET NO.
9

