



### Product Data

<b>Project Name:</b>	Factory 52 - Market Hall - Innovation Hub	<b>Submittal Code:</b>	237433.00-PD-00	<b>REV:</b>	00
<b>Document Set:</b>	Bid/Construction				
<b>KLH Project #:</b>	22552.01-Bid	<b>Received Date:</b>	12/07/2021		
<b>Section Name:</b>	Packaged Outdoor Rooftop Units				
<b>Section Number:</b>	237433.00				
<b>Submitted By:</b>	HGC Construction Co.				
<b>Authored By:</b>	Cincinnati Air Conditioning				
<b>Client Name:</b>	MSA Design				

SUBMITTAL REVIEW

Exceptions Noted

By: Jennifer C. Adamec      Date: 12/13/2021

ENGINEER'S REVIEW IS FOR GENERAL CONFORMANCE WITH THE CONTRACT DOCUMENTS. COMMENTS DO NOT RELIEVE THE CONTRACTOR FROM COMPLIANCE WITH THE CONTRACT DOCUMENTS. THE CONTRACTOR REMAINS RESPONSIBLE FOR ACCURACY OF QUANTITIES, DIMENSIONS, DETAILS AND COORDINATION WITH OTHER TRADES.

#### MAU-1-4

- 1.1 No exceptions noted for submitted Aeon model for (4) MAUs. Final system design for (4) MAUs pending architect and owner approval for facade related approval and structural approval for roof structural support.

#### End of Submittal Review

- Reviewed
- Reviewed & Revisions Noted
- Revise & Resubmit
- Other \_\_\_\_\_

Review is for general conformance and design concept. Contractor is responsible for dimensions, quantities, coordination with other trades, techniques of construction and performing his work in a safe and satisfactory manner. Review does not relieve Contractor from responsibility for errors or deviations from contract requirements. Notations do not authorize an extra cost.

Alex Spencer
1/26/2022

Signature
Date

MSA DESIGN

**Note:** Additional submittals are not required where "Exceptions Noted" is indicated. It will be assumed however that all necessary corrections will be executed. Provide as-built record copies within OM Manuals at project close-out (not before) for all affected submittals.

*This Page  
Intentionally  
Left Blank*



HGC Construction Co.  
 2814 Stanton Avenue  
 Cincinnati, Ohio 45206  
 P: (513) 861-8866  
 F: (513) 861-7878

Project: 121507 F52: Food Innovation Hub GMP  
 02  
 2750 Park Ave.  
 Norwood, Ohio 45212

## Submittal #237433-23A.32.0 - F42: Food Innovation Hub - MAU - Alternate (4 Units) 237433 - Packaged Outdoor Rooftop Units

<b>Revision</b>	0	<b>Submittal Manager</b>	Kristin Carson (HGC Construction Co.)
<b>Status</b>	Open	<b>Date Created</b>	Dec 7, 2021
<b>Issue Date</b>	Dec 7, 2021	<b>Spec Section</b>	237433 - Packaged Outdoor Rooftop Units
<b>Responsible Contractor</b>	Cincinnati Air Conditioning Co	<b>Received From</b>	Ken Wietmarschen (Cincinnati Air Conditioning Co)
<b>Received Date</b>	Nov 23, 2021	<b>Submit By</b>	Dec 7, 2021
<b>Final Due Date</b>	Dec 17, 2021	<b>Lead Time</b>	
		<b>Cost Code</b>	
<b>Location</b>		<b>Type</b>	Product Data
<b>Approvers</b>	Kristin Carson (HGC Construction Co.), Admin (KLH Engineers), Alex Spencer (MSA Architects)		
<b>Ball in Court</b>	Admin (KLH Engineers), Alex Spencer (MSA Architects)		
<b>Distribution</b>	Greg Roach (HGC Construction Co.), Mark Morrison (PLK Communities), Kevin Gilbert (HGC Construction Co.), Michael Collins (J.S. Held)		
<b>Description</b>	<p>Jennifer,</p> <p>Please see the attached submittal for from Cincinnati Air for the alternate MAU solution with 4 units.</p> <p>Note: this submittal will not be released for purchase until design completion/owner approval.</p> <p>Thanks,</p> <p>Kristin</p>		

### Submittal Workflow

Name	Sent Date	Due Date	Returned Date	Response	Attachments
General Information Attachments					Submittals for 4 MUA – FACTORY 52 INNOVATION HUB AAON SUBMITTAL 11-23-REV.pdf
Kristin Carson	Dec 7, 2021	Dec 7, 2021	Dec 7, 2021	Submitted	<a href="#">Submittals for 4 MUA - FACTORY 52 INNOVATION HUB AAON SUBMITTAL 11-23 REV.pdf (Current)</a>
Admin		Dec 17, 2021		Pending	
Alex Spencer	Dec 7, 2021	Dec 17, 2021		Pending	

# 121507 - F52: Food Innovation Hub GMP 02

2750 Park Ave.  
Norwood, Ohio 45212  
United States



HGC Construction Co.  
2814 Stanton Avenue  
Cincinnati, Ohio 45206  
United States  
(513) 861-8866

Title Submittal Manager  
F42: Food Innovation Hub - MAU - Alternate (4 Units) Kristin Carson

Spec Section Type  
237433 - Packaged Outdoor Rooftop Units Product Data

Number Rev  
237433-23A.32 0

## Description

Jennifer,

Please see the attached submittal for from Cincinnati Air for the alternate MAU solution with 4 units.

Note: this submittal will not be released for purchase until design completion/owner approval.

Thanks,

Kristin



2814 STANTON AVENUE, CINCINNATI, OH 45206

---

Reviewed by Kristin Carson

Reviewed – No Exceptions Noted

Reviewed – Exceptions Noted

Exceptions Noted – Revise and Resubmit

---

This print has been reviewed as to general layout but does not relieve the subcontractor of responsibility under the contract documents. Detailed dimensions and proper integration of equipment and/or materials are the responsibility of the subcontractor.



# Unit Rating

2425 South Yukon Ave - Tulsa, Oklahoma 74107-2728 - Ph. (918) 583-2266 Fax (918) 583-6094  
AAONEcat32 Ver. 4.315 (SN: 6254160-)

1A 1B 1C 1D 2 3 4 5A 5B 5C 6A 6B 6C 7 8 9 10 11 12 13 14A 14B 15 16 17 18 19 20 21 22 23

**RN-030-8-0-EB09-3CB : M000-U0A-DQG-000-0TE0H0F-00-00C1000VB**

Tag: MUA# 1,2,3,4

## Job Information

Job Name: *Factory 52 Market Hall*  
Job Number: *Job #2018021021*  
Site Altitude: *0 ft*  
Refrigerant: *R-410A*

## Static Pressure

External: *2.00 in. wg.*  
Evaporator: *0.33 in. wg.*  
Filters Clean: *0.10 in. wg.*  
Dirt Allowance: *0.35 in. wg.*

## Cooling Section

	Gross	Net
Total Capacity:	<i>359.61</i>	<i>348.06 MBH</i>
Sensible Capacity:	<i>222.48</i>	<i>210.93 MBH</i>
Latent Capacity:	<i>137.13 MBH</i>	
Mixed Air Temp:	<i>93.00 °F DB</i>	<i>75.00 °F WB</i>
Entering Air Temp:	<i>93.00 °F DB</i>	<i>75.00 °F WB</i>
Lv Air Temp (Coil):	<i>55.49 °F DB</i>	<i>55.27 °F WB</i>
Lv Air Temp (Unit):	<i>57.33 °F DB</i>	<i>56.00 °F WB</i>
Digital Comp. Capacity Ratio:	<i>100%</i>	

Supply Air Fan: *1 x 270D60 @ 4.13 BHP*  
SA Fan RPM / Width: *1317 / 3.680"*

Evaporator Coil: *19.9 ft² / 6 Rows / 12 FPI*  
Evaporator Face Velocity: *289.5 fpm*

## Rating Information

Cooling Capacity (MBH): *322.0*  
Cooling EER: *10.9*  
Cooling IEER: *12*

*Rated in accordance with AHRI 340/360*

Application EER @ Op. Conditions: *11.3*

## Electrical Data

Rating: *208/3/60*  
Unit FLA: *148*  
SCCR: *10 KAIC*

Minimum Circuit Amp: *161*  
Maximum Overcurrent: *200*

	Qty	HP	VAC	Phase	RPM	FLA	RLA
Compressor 1:	1		208	3			51.3
Compressor 2:	1		208	3			51.3
Condenser Fans:	3	1.00	208	1	1110	7.0	
Supply Fan:	1	7.50	208	3	1760	24.2	
Combustion:	2	0.25	208	1	3210	1.7	

## Cabinet Sound Power Levels\*

Octave Bands:	63	125	250	500	1000	2000	4000	8000
Discharge LW(dB):	90	89	91	89	86	86	86	82
Return LW(dB):	77	76	73	67	69	67	64	57

\*Sound power levels are given for informational purposes only. The sound levels are not guaranteed.

## Unit Information

Approx. Op./Ship Weights: *2800 / 2800 lbs. (±5%)*  
Supply CFM/ESP: *5750 / 2 in. wg.*  
Final Filter FV / Qty: *276.00 fpm / 6*  
Outside CFM: *5750*  
Ambient Temperature: *93 °F DB / 75 °F WB*

Economizer: *0.00 in. wg.*  
Heating: *0.18 in. wg.*  
Cabinet: *0.03 in. wg.*  
Re-Heat Coil: *0.04 in. wg.*  
Total: *3.04 in. wg.*

## Heating Section

PreHeat Type: *Std (No Preheat)*

Heating Type: *Nat. Gas Heat*  
Heating CFM: *5750*

Total Capacity: *432.0 MBH*  
OA Temp: *0.0 °F DB / -1.0 °F WB*  
RA Temp: *72.0 °F DB / 58.0 °F WB*  
Entering Air Temp: *0.0 °F DB / -1.0 °F WB*  
Leaving Air Temp: *69.5 °F DB / 44.4 °F WB*  
Input: *540.0 MBH*  
Heater Qty: *1*  
Consumption: *540.0 MBH*  
Total Turndown Ratio: *18:1*

## Re-Heat Coil:

Capacity: *115 MBH*  
LA DB / WB: *74.00 °F / 62.19 °F*  
RH: *52%*



# 27.0" STAR Plenum

2425 South Yukon Ave - Tulsa, Oklahoma 74107-2728 - Ph. (918) 583-2266 Fax (918) 583-6094  
AAONEcat32 Ver. 4.315 (SN: 6254160-)

## JOB INFORMATION:

Job Name: *Factory 52 Market Hall*  
 Job Tag: *MUA# 1,2,3,4*  
 Rep Firm: *Jared Limbach*  
 Date: *11/23/2021*

## WHEEL SPECIFICATION:

Max RPM: *1,800*  
 Diameter x Qty: *27.4 in. x 1*  
 Width%: *100*  
 Tip Speed: *9,447 FPM*  
 Inertia: *16 WR<sup>2</sup>*

## OPERATING CONDITIONS:

Air Flow: *5,750 CFM*  
 Static Pressure: *3.04 in. Wg.*  
 Plenum DP: *0.00 in. Wg.*  
 Inlet Grill DP: *0.00 in. Wg.*  
 TSP: *3.04 in. Wg.*  
 Site Altitude: *0.00 Ft*  
 TSP @ Sea Level: *3.04 in. Wg.*

## MOTOR SELECTION:

Rated HP / Bypass: *7.5 / No*  
 Frame Size: *213T*  
 Nominal RPM: *1760*  
 VAC/PH/HZ: *208/3/60*  
 Efficiency: *Premium / 0.91*  
 Enclosure Type: *ODP*  
 Max Inertial Load: *64 WR<sup>2</sup>*

## FAN PERFORMANCE:

RPM: *1317*  
 BHP: *4.13*  
 Efficiency: *66.7%*  
 In/Out Velocity: *1501/1571 FPM*  
 Plenum Out Velocity: *96 FPM*

## FAN SOUND POWER (Inlet/Outlet):

Octave Band:		(Re 10 <sup>-12</sup> watts)						
1	2	3	4	5	6	7	8	
88	86	84	83	83	83	83	82	
90	89	91	91	89	90	90	86	

SOUND POWER A-Weighted: **91 / 96 dB**

Max Duct SP with Blocked Airway: **4 in. Wg. @ 1317 rpm**

Supply Fan Model: 270D60 @ 1317 RPM and 100% Width  
 Design Conditions: 5750 CFM @ 3.04" SP

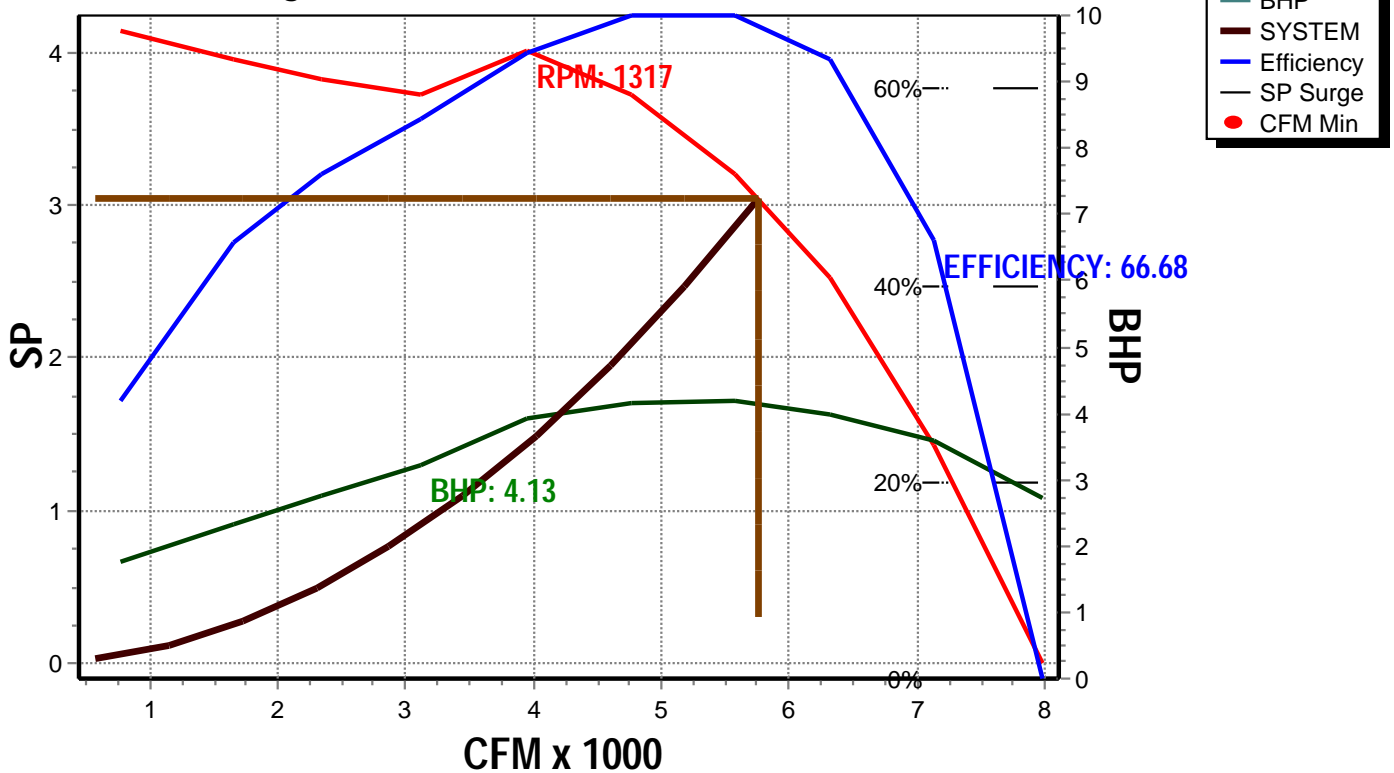



# Unit Submittal

2425 South Yukon Ave - Tulsa, Oklahoma 74107-2728 - Ph. (918) 583-2266 Fax (918) 583-6094  
AAONEcat32 Ver. 4.315 (SN: 6254160-)

1A 1B 1C 1D 2 3 4 5A 5B 5C 6A 6B 6C 7 8 9 10 11 12 13 14A 14B 15 16 17 18 19 20 21 22 23

**RN-030-8-0-EB09-3CB:M000-U0A-DQG-000-0TE0H0F-00-00C1000VB**  
Tag: MUA# 1,2,3,4

Job Name:  
Job Number:

Factory 52 Market Hall  
Job #2018021021

Unit Submittal For:  
Unit Submittal Date:

November 23, 2021

	Base Option	Description
<b>R</b>	Series	Roof Top Unit
<b>N</b>	Generation	Ninth Generation
<b>030</b>	Unit Size	Thirty
<b>8</b>	Voltage	208V/3Ø/60Hz
<b>0</b>	Interior Protection	Standard
<b>E</b>	Refrigerant Style	R-410A Variable Capacity Scroll Compressor (VCC)
<b>B</b>	Unit Configuration	Air-Cooled Cond. + 6 Row Evap. Coil
<b>0</b>	Coil Coating	Standard
<b>9</b>	Cooling/Heat Pump Staging	Modulating - 1 VCC + 1 On/Off Comp.
<b>3</b>	Heating Type	Natural Gas Stainless Steel
<b>C</b>	Heating Designation	Heat C - 540 MBtuh
<b>B</b>	Heating Staging	High Turndown Modulating Gas - Temperature Control

	Feature Option	Description
<b>M</b>	<b>1A.</b> RA/OA Section	Motorized 100% Outside Air Dampers - No RA Opening
<b>0</b>	<b>1B.</b> RA/EA Blower Configuration	Standard - None
<b>0</b>	<b>1C.</b> RA/EA Blower	Standard - None
<b>0</b>	<b>1D.</b> RA/EA Blower Motor	Standard - None
<b>U</b>	<b>2.</b> OA Control	2 Position Actuator
<b>0</b>	<b>3.</b> Heat Options	Standard
<b>A</b>	<b>4.</b> Maintenance Options	115V Convenience Outlet - Field Wired
<b>D</b>	<b>5A.</b> SA Blower Configuration	1 Blower + Premium Efficiency Motor + 1 VFD
<b>Q</b>	<b>5B.</b> SA Blower	27" <b>Direct Drive</b> Backward Curved Plenum - 60% Width
<b>G</b>	<b>5C.</b> SA Motor	7.5 hp - 1760 rpm
<b>0</b>	<b>6A.</b> Pre Filter Type	Standard - None
<b>0</b>	<b>6B.</b> Unit Filter Type	2" Pleated - 30% Eff
<b>0</b>	<b>6C.</b> Filter Options	Standard
<b>0</b>	<b>7.</b> Refrigeration Control	Standard - Adj Comp. Cooling Lock Out Through Unit Controls
<b>T</b>	<b>8.</b> Refrigeration Options	Parallel Modulating Hot Gas Reheat Microchannel Coil [MHGR-MC] - Lag Circuit
<b>E</b>	<b>9.</b> Refrigeration Accessories	ECM Condenser Fan - Head Pressure Control
<b>0</b>	<b>10.</b> Power Options	Standard Power Block
<b>H</b>	<b>11.</b> Safety Options	Remote Safety Shutdown Terminals
<b>0</b>	<b>12.</b> Controls	Standard
<b>F</b>	<b>13.</b> Special Controls	Make Up Air Unit Controller - CV Cool + CV Heat
<b>0</b>	<b>14A.</b> Outside Air Configuration	Standard - None
<b>0</b>	<b>14B.</b> Preheat Sizing	Standard - None
<b>0</b>	<b>15.</b> Glycol Percent	Water or No WSHP
<b>0</b>	<b>16.</b> Interior Cabinet Options	Standard - Double Wall + R-13 Foam Insulation + Stainless Steel Drain Pan
<b>C</b>	<b>17.</b> Exterior Cabinet Options	Cond. Coil Guards
<b>1</b>	<b>18.</b> Electrical Rating	10 KAIC
<b>0</b>	<b>19.</b> Code Options	Standard - ETL U.S.A. Listing
<b>0</b>	<b>20.</b> Crating	Standard
<b>0</b>	<b>21.</b> Water-Cooled Cond.	Standard - None
<b>V</b>	<b>22.</b> Control Vendors	VCC-X Controls + Integrated BACnet MSTP
<b>B</b>	<b>23.</b> Type	Standard - Includes AAON Gray Paint



# VCCX Components

2425 South Yukon Ave - Tulsa, Oklahoma 74107-2728 - Ph. (918) 583-2266 Fax (918) 583-6094  
AAONEcat32 Ver. 4.315 (SN: 6254160-)

1A 1B 1C 1D 2 3 4 5A 5B 5C 6A 6B 6C 7 8 9 10 11 12 13 14A 14B 15 16 17 18 19 20 21 22 23

**RN-030-8-0-EB09-3CB:M000-U0A-DQG-000-0TE0H0F-00-00C1000VB**

Tag: MUA# 1,2,3,4

Job Name:

*Factory 52 Market Hall*

VCCX For:

Job Number:

*Job #2018021021*

VCCX Date:

*November 23, 2021*

## Hardware Included For VCCX Controller

Part #	Included Parts	Assigned Channel	BACnet Point
ASM01698	VCCX2 CONTROLLER		
ASM01692	OSA Temp/Hum Sensor	EBUS2 communicating sensor	AI:16, AI:17, AI:18, AI:19
R82890	Supply Temp Sensor - Field Installed	VCCX control point AI 3	AI:9
	Supply Fan Control Signal 0-10VDC	VCCX control point AO 1	AI:22
	Economizer	VCCX control point AO 2	AI:30
R62330	Proof of Air Flow	VCCX control point BI 1	BI:6, BI:24
	Safety Shut Down	VCCX control point BI 8	BI:26
	Supply Fan	Configured Relay Point	BI:47
ASM02201	DIGITAL REFRIGERATION MODULE		
R42680	Comp Discharge Temp A	RSMD point TEMP1	AI:66
V38391	Suction Pressure Sensor A	RSMD point SP-1	AI:48
V38410	Discharge Pressure Sensor A	RSMD point HP-1	AI:50
V38410	Discharge Pressure Sensor B	RSMD point HP-2	AI:75
R63950 (2)	Modulated Condenser Signal AB	RSMD point AO1	AI:46
	Comp Status Input A	RSMD point BIN1	BI:77
	Comp Status Input B	RSMD point BIN2	BI:78
	Emergency Shutdown	RSMD point BIN4	BI:83
	Comp Unload Signal A	RSMD point T1	AI:44
	Comp Enable A	RSMD Fixed Relay point	BI:84
	Comp Enable B	RSMD Fixed Relay point	BI:85
ASM01670	MODULATING HOT GAS REHEAT MODULE		
	Reheat HGR Valve	MHGRV-X	AI:42
ASM01695	MODULATING GAS MODULE		
	Gas Valve Signal 1B	MODGAS-XWR Gas Valve 2	
	Gas Valve Signal 1A	MODGAS-XWR Gas Valve 1	
	Proof of Ignition 1B	MODGAS-XWR BI4	
	Proof of Ignition 1A	MODGAS-XWR BI3	
	Heat Stage 4 (IGN 2H)	MODGAS-XWR Heat 4 Relay	
	Heat Stage 3 (IGN 2L)	MODGAS-XWR Heat 3 Relay	
	Mod Heat Stage 2 (IGN 1B)	MODGAS-XWR Heat 2 Relay	
	Mod Heat Stage 1 (IGN 1)	MODGAS-XWR Heat 1 Relay	
	Low Speed Enable	MODGAS-XWR Low Speed Relay	

# RN SERIES C - CABINET STANDARD ~ 16-30 TON

CLEARANCES	
LOCATION	• UNIT SIZE • 16 - 30 TON
OUTSIDE AIR (BACK)	48
CONTROLS SIDE (FRONT)	48
LEFT SIDE	6
RIGHT SIDE	60
TOP	UNOBSTRUCTED

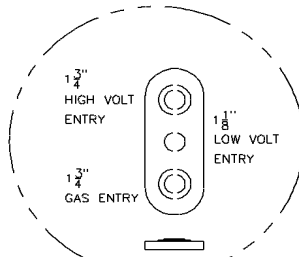

DETAIL A

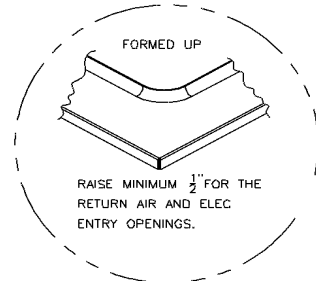

DETAIL B

**NUMBER OF CONDENSER FANS**

- 16,18 & 20 TON - 2 FANS
- 25 & 30 TON - 3 FANS

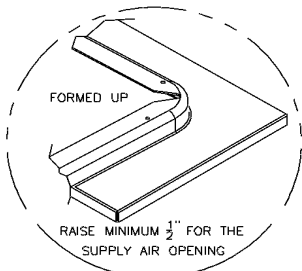

DETAIL C

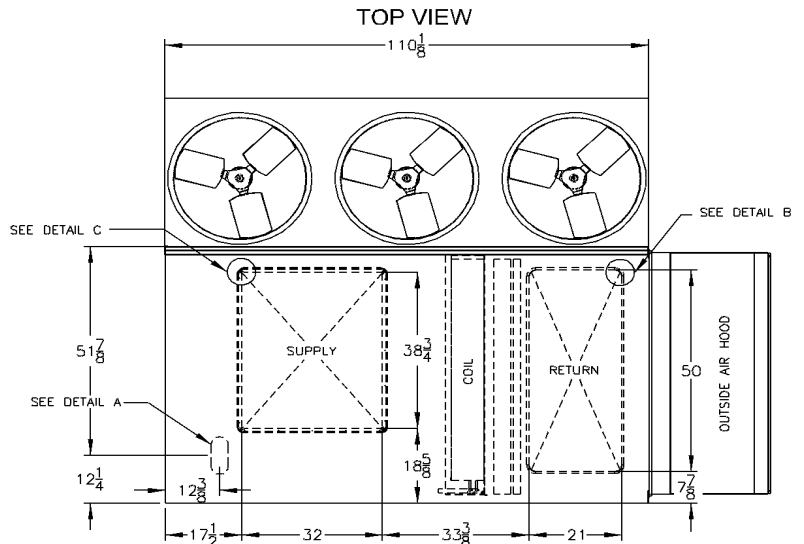

FRONT VIEW

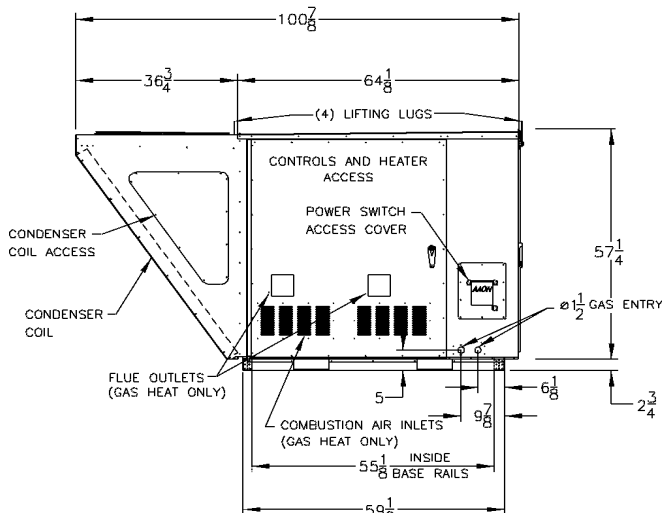

RNC-00001 REV:D 08/20/10 JWC

NOTE: ALL DIMENSIONS ARE IN INCHES

RIGHT SIDE VIEW

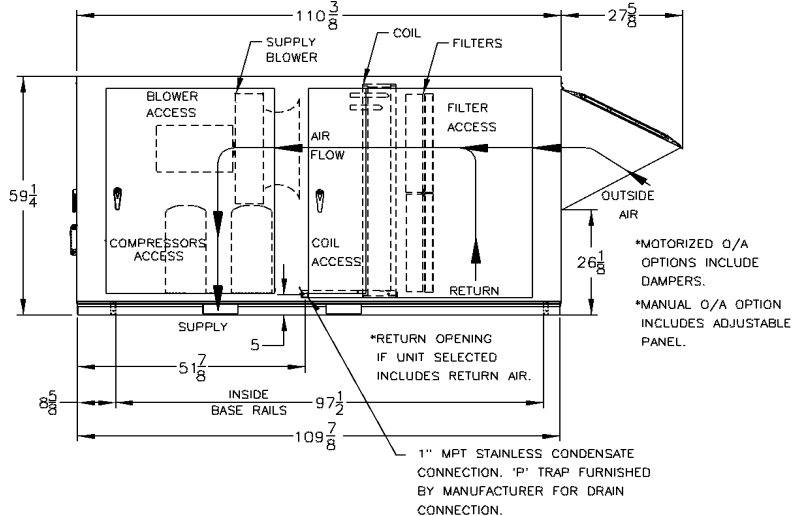

\*1" MPT STAINLESS CONDENSATE CONNECTION. 'P' TRAP FURNISHED BY MANUFACTURER FOR DRAIN CONNECTION.

# RNC CABINET AIR COOLED CONDENSING UNIT



RN-030-8-0-EB09-3CB:M000-U0A-DQG-000-0TE0H0F-00-00C1000VB

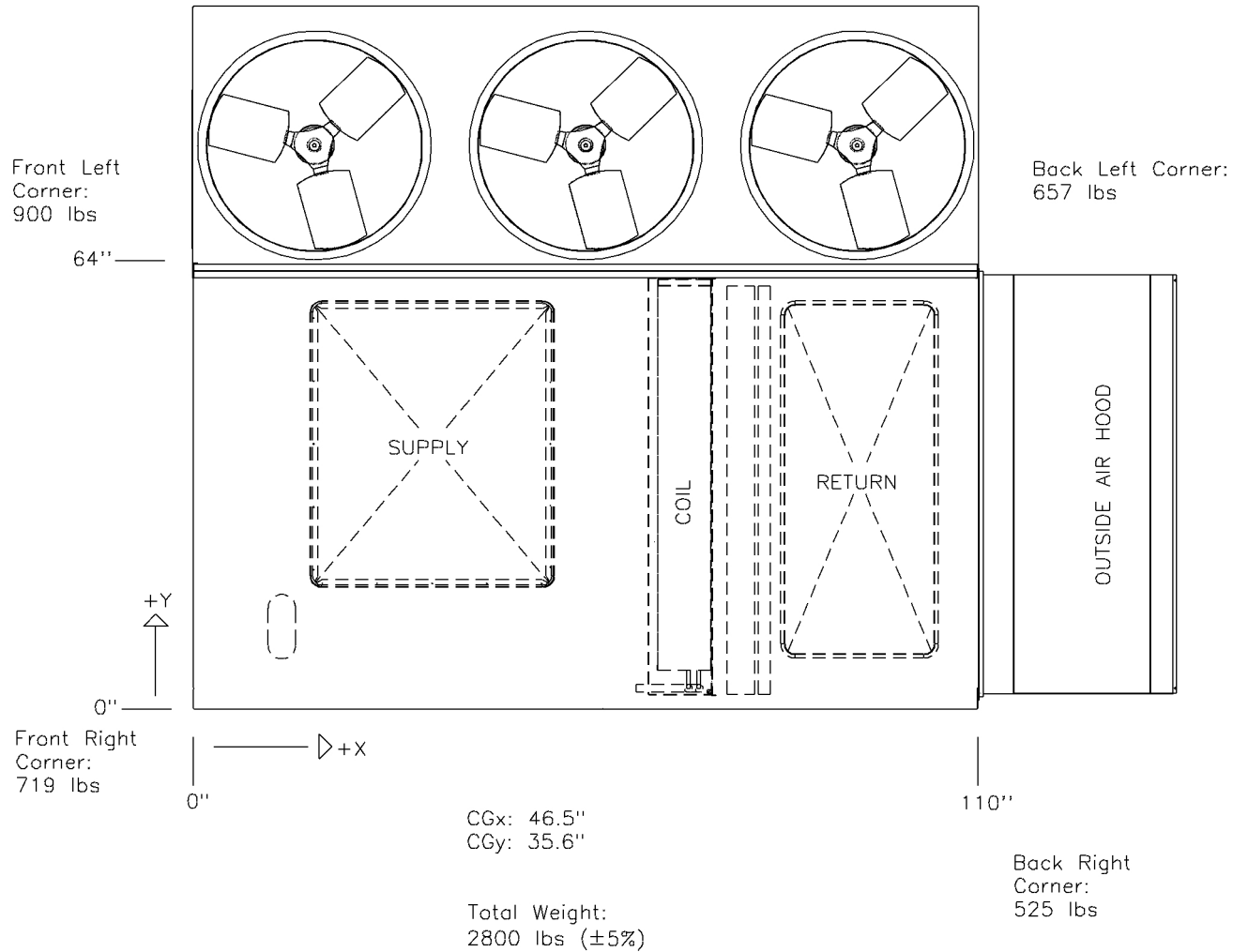

Disclaimer:  
This weight estimate does not account for any SPAs.

RN SERIES  
 C-CABINET SOLID BOTTOM CURB STANDARD AND  
 POWER EXHAUST ~ 16-30 TON

TOP VIEW

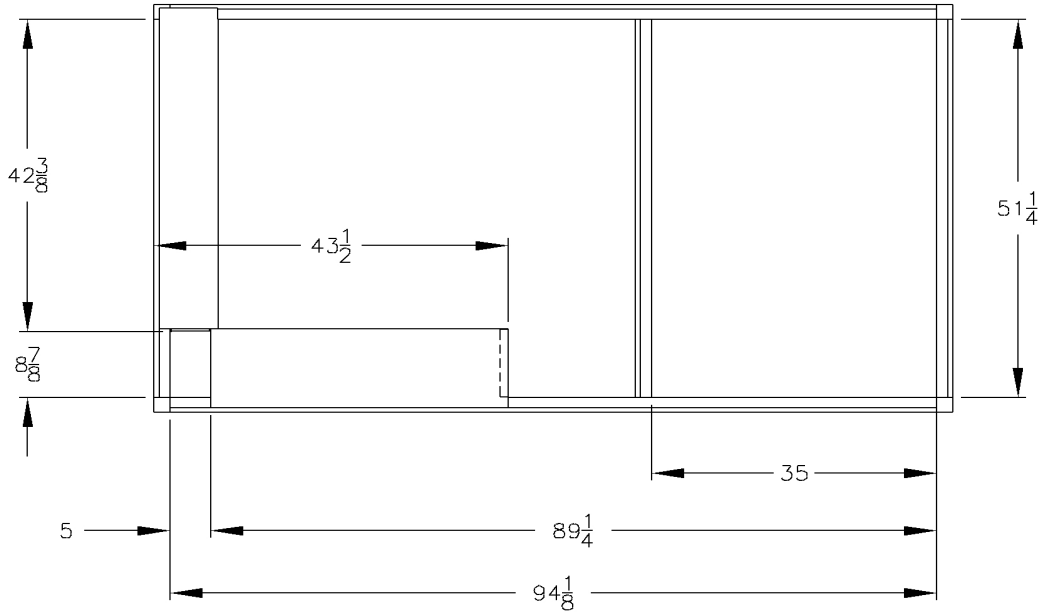

SIDE VIEW

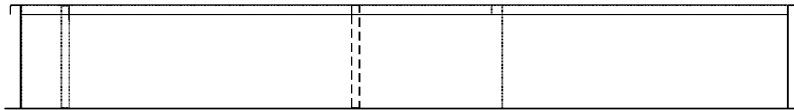

CURB WEIGHT  
 14IN CURB= 167LBS  
 24IN CURB= 223LBS

