



W.W. Gay
 515 SE 11th Place
 Gainesville, Florida 32601
 P: (352) 372-3963

Project: 8550163 Palatka Army Reserve

Submittal #23 30 00-1.1 - 23 30 00 - HVAC Air Distribution - Split System 23 30 00 - HVAC AIR DISTRIBUTION

Revision	1	Submittal Manager	Rachel Roper (W.W. Gay Mechanical Contractor, Inc.)
Status	Submitted to CM	Date Created	Nov 27, 2023
Issue Date	Nov 27, 2023	Spec Section	23 30 00 - HVAC AIR DISTRIBUTION
Responsible Contractor		Received From	
Received Date		Submit By	
Final Due Date	Dec 25, 2023	Lead Time	
		Cost Code	
Location		Type	Product Data
Approvers	Gary Pate		
Ball in Court	Gary Pate		
Distribution			
Description	Product Data for Split System		

Submittal Workflow

Name	Sent Date	Due Date	Returned Date	Response	Attachments
General Information Attachments					
Rachel Roper	Feb 13, 2024	Dec 11, 2023	Feb 13, 2024	Submitted	US Army Reserve Center Palatka FL DOAS Split System Submittal REV1 02-06-2024.pdf (Current)
Comment	Revised O/A Unit				
Gary Pate	Nov 27, 2023	Dec 25, 2023		Pending	



Revised Submittal

Date: February 06, 2024

Job Name:
US Army Reserve Center Palatka FL

Trane U.S. Inc. is pleased to provide the following submittal for your review and approval. Based on plans and specifications dated 06/20/2022.

Product Summary

Qty Product

- 1 Performance Climate Changer (UCCA)
- 1 Odyssey Split System Outdoor Unit

NOTES:

1. Unit re-selected as UCCA air handler because of space constraints. Because of this Trane will install a custom cooling coil along with a hot gas reheat coil.
2. Custom cooling coil performance can be found in page 6. Please review performance and advice.
3. Hot Gas Reheat coil performance can be found in page 7. Please review performance and advice.
4. Outdoor unit is dual circuit with dual compressor. Compressor on the main circuit is a digital scroll compressor as specified.
5. Confirm unit handing prior to release for production.
6. Condensing unit corrosion coating product data is attached to this submittal.

Tyler Gesse (CO)
Account Manager
Trane U.S. Inc.
2301 Lucien Way, Suite 430
Maitland, FL 32751
Office Phone: (407) 660-1111
Fax: (407) 660-0303

The attached information describes the equipment we propose to furnish for this project and is submitted for your approval.

Submittal acceptance and return is a critical step, so please ensure submittals are returned with approval to release to production within 14 days of submittal date.

Product performance and submittal data is valid for a period of 6 months from the date of submittal generation. If six months or more has elapsed between submittal generation and equipment release, the product performance and submittal data will need to be verified. It is the customer's responsibility to obtain such verification.

Table of Contents

Product Summary	1
Performance Climate Changer (UCCA) (Item A1)	3
Tag Data	3
Product Data.....	3
Product Report.....	4
Mechanical Specifications	8
Dimensional Drawings	11
Fan Curve	20
Accessory	21
Field Wiring.....	28
Odyssey Split System Outdoor Unit (Item B1)	29
Tag Data	29
Product Data.....	29
Product Report.....	30
Mechanical Specifications	31
Dimensional Drawings.....	34
Weight, Clearance & Rigging	38
Field Installed Options - Part/Order Number Summary	40
Performance Climate Changer (UCCA)	40
Odyssey Split System Outdoor Unit	40

Tag Data - Performance Climate Changer (UCCA) (Qty: 1)

Item	Tag(s)	Qty	Description	Model Number
A1	OAHU-1	1	Performance Climate Changer (UCCA)	UCCAG06C0G0F00035015A0DD878CA0AC00100001

Product Data - Performance Climate Changer (UCCA)

Item: A1 Qty: 1 Tag(s): OAHU-1

Performance Climate Changer (UCCA)

Horizontal DDP fan with front top discharge

Unit Size 6 Square Feet of Coil

460/60/3

Indoor unit

Stainless Steel Drain Pan, LH Coil / LH Motor & Drive Location

UC600 controller plus starter or disconnect

SSR control

Electric heat with 15.0 kW

Line fuse, door interlocking disconnect and air flow switch

3 horsepower motor per fan (supply)

FC or DDP fan w/VFD and shaft grounding

Direct drive plenum fan / motorized impeller fan
78 Hz / 2317 RPM

2" angle filter section

2" MERV 8

Discharge air sensor

Outside air temperature and duct static press sensor, fact-provided, ships loose (Field Installed)

UV lights on cooling coil section.

Additional Options:

DX Coil

Dual Intertwined Circuits

Hot Gas Reheat Coil

Single Circuit

Additional options are covered by TCS 1 year parts only warranty

Product Report - Performance Climate Changer (UCCA)
 Item: A1 Qty: 1 Tag(s): OAHU-1

Air Handler Model UCCA

Unit Overview - UCCAG06C0G0F00035015A0DD878CA0AC00100001									
Application	Unit Size	Supply Fan		External Dimensions (in.)			Weight		Elevation
Indoor unit	6	Airflow	Total Static Pressure	Height	Width	Length	Installed	Rigging	0.00 ft
		2100 cfm	2.856 in H2O	38.500 in	47.000 in	122.310 in	1087.2 lb	1087.2 lb	

Unit Features	
Panel	2 in. Foam Injected R-13
Panel Material	Galvanized
Configuration	Horizontal DDP fan with front top discharge
Coil, Drain and Motor side	Stainless Steel Drain Pan, LH Coil / LH Motor & Drive Location

Unit Electrical	
Unit Voltage	SF Motor(s) + HV + CONT + EH
Unit Voltage 460/60/3	FLA 24.06 A
	MCA 29.96 A
	Max fuse size 30.00 A

Controls	
Controller Type	UC600
Controls Options 2	Discharge air sensor
Controls Options 3	Outside air temperature and duct static press sensor, fact-provided, ships loose

Filter	
Type	Angled
Merv Rating	2" MERV 8
20 in. x 20 in. Quantity	4
Pressure Drop	0.536 in H2O
Condition	Mid-life
Airflow	2100 cfm

Heating Section (Re-Heat)	
Coil Construction and Options	Coil Performance
Re-heat Coil System Type	Capacity
Electric Heat / Factory Mount Only	Total Re-heat Capacity
Electric Heat Options	Air
Electric Heat kW	Re-heat Airflow
	Re-heat Entering Air Temp
	Re-heat Leaving Air Temp
	Re-heat Pressure Drop

Supply Fan Section		
Fan Data	Motor Data	
Fan Type	Power / Fan	
Fan Quantity	Voltage	
Fan Performance	Fan electrical power (FEP)	
Airflow	Wire to air static efficiency	
Total Static Pressure	Note: VFD driven motor fan electrical power calculated in accordance with AHRI 430.	
Total Brake Power / Fan	Fan Discharge	
Operating Speed	Airflow	
AMCA FEG	Face Velocity	
Motor Interface		
Type		
Voltage		
VFD Frequency/DDP Fan Speed		

Product Report - Performance Climate Changer (UCCA)

Item: A1 Qty: 1 Tag(s): OAHU-1



Central Station Air-Handling Unit Supply Fans
AHRI Standard 430/431

Note: Certified by the AHRI Central Station Air-Handling Unit (AHU) Certification Program, based on AHRI Standard 430/431. AHRI certified units are subject to rigorous and continuous testing, have performance ratings independently measured and are third party verified. Certified units may be found in the AHRI Directory at www.ahridirectory.org.



Central Station Air-Handling Unit Supply Fans
AHRI Standard 430/431

Static Pressure Section	
Filter/Mixing Air Pressure Drop	0.536 in H2O
Reheat Air Pressure Drop	0.136 in H2O
External Static Pressure	1.750 in H2O
Discharge Pressure Drop	0.434 in H2O
Supply Fan Total Static Pressure	2.856 in H2O

AHRI Certification	
Data generation date	2/6/2024
Trane Select Assist update number	2790

DX Coil

Evaporator Coil	Coil Qty: 1	Model: 22x36 - 6R - 0.375/144
Input		
<i>Finside Requirements:</i>		
Coil Application:		Cooling
Surface Condition:		Wet
Air Flow:	SCFM	1,310
Capacity:	Btu/Hr.	110,000
Entering Air Dry-Bulb:	°F	94.0
Entering Air Wet-Bulb:	°F	77.0
Leaving Air Wet-Bulb:	°F	51.8
Air Pressure:	PSIA	14.696
Coil Hand:		Right Hand
<i> Tubeside Requirements:</i>		
Refrigerant:		R-410A
Refrigerant Suction Temp.:	°F	45.5
Degrees Superheat:	°F	15.0
Liquid Temperature:	°F	115.0
Refrig. Mass Flow:	Lbs./Hr.	1.693
Vapor Tube Velocity:	Ft/Second	12.2
Vapor Suction Velocity:	Ft/Second	18.0
Output		
<i>Coil Selection:</i>		
Model Number:		22x36 - 6R - 0.375/144
Tube Size:	In.	0.375
Arrangement:		1 x 0.866 Staggered
Fin Surface:		Corrugated
Face Area / Coil:	ft²	5.5
Face Velocity / Coil:	Ft/Min. (STD)	238.2
# Circuits Hdr 1:	Qty	11
# Circuits Hdr 2:	Qty	11
Total # Circuits:	Qty	22
Circuitry Flow:		Thermal Parallel Flow
Tube Material:		Copper
Tube Wall:	In.	0.015
Fin Material:		Aluminum
Fin Thickness:	In.	0.0055
Header Material:		Std.Type 'L' Copper
Header 1 OD:	In.	1.125
Header 2 OD:	In.	1.125
Connection Material:		Std.Type 'L' Copper
Connection 1 OD:	In.	1.125
Connection 2 OD:	In.	1.125
Casing Material:		16 Ga. Galv. Steel (Std.)
Casing Depth:	In.	7.250
Dry Weight:	Lbs./Coil	89
Coil Rating		
<i>Capacity:</i>		
Capacity / Coil:	Btu/Hr.	113,015
Sensible Cap. / Coil:	Btu/Hr.	60,932
Leaving Air Dry-Bulb:	°F	51.2
Leaving Air Wet-Bulb:	°F	50.9
Air Friction:	In.H2O/Coil	0.30
Surface Condition:		Wet
Refrigerant Inlet Temp.:	°F	45.8
Refrig. Press. Drop:	PSI/Coil	0.938
Circuit Loading:	Btu/Hr.	5,137
Internal Volume:	ft³	0.29

Hot Gas Reheat Coil

Condenser Coil	Coil Qty: 1	Model: 22x36 - 1R - 0.313/240
Input		
<i>Finside Requirements:</i>		
Surface Condition:		Dry
Air Flow:	SCFM	1,310
Capacity:	Btu/Hr.	28,000
Entering Air Dry-Bulb:	°F	51.2
Leaving Air Dry-Bulb:	°F	70.6
Air Pressure:	PSIA	14.696
Coil Hand:		Right Hand
<i> Tubeside Requirements:</i>		
Refrigerant:		R-410A
Condensing Temp.:	°F	95.0
Hot Gas Temp.:	°F	150.0
Subcooling Degrees:	°F	15.0
Output		
<i>Coil Selection:</i>		
Model Number:		22x36 - 1R - 0.313/240
Tube Size:	In.	0.313
Arrangement:		1 x 0.625 Staggered
Fin Surface:		Corrugated
Face Area / Coil:	ft²	5.5
Face Velocity / Coil:	Ft/Min. (STD)	238.2
Number of Circuits:	Qty	3
Subcl. Fin Height:	In.	4.00
Subcl. Flow:	Type	Cross Flow
Subcl. Number Of Circuits:		1
Circuitry Flow:		Cross Flow
Tube Material:		Copper
Tube Wall:	In.	0.015
Fin Material:		Aluminum
Fin Thickness:	In.	0.0075
Header Material:		Std. Type 'L' Copper
Header OD (HG/Liq):	In.	0.5 / 0.375
Connection OD:	In.	0.5 / 0.375
Casing Material:		16 Ga. Galv. Steel (Std.)
Casing Depth:	In.	3.250
Dry Weight:	Lbs./Coil	30
Coil Rating		
<i>Capacity:</i>		
Capacity / Coil:	Btu/Hr.	28,342
Leaving Air Dry-Bulb:	°F	70.4
Air Friction:	In.H2O/Coil	0.04
Surface Condition:		Dry
Subcooling Degrees:	°F	20.7
Refrig. Press. Drop:	PSI/Coil	3.083
Refrig. Mass Flow:	Lbs./Hr.	286

Mechanical Specifications - Performance Climate Changer (UCCA)

Item: A1 Qty: 1 Tag(s): OAHU-1

GENERAL**Lifting Instructions**

Performance Climate Changer air handlers must be rigged, lifted, and installed in strict accordance with the Installation, Operation, and Maintenance manual (CLCH-SVX009*-EN) for UCCA air handlers. The units are also to be installed in strict accordance with the specifications.

Units shall be shipped on an integral 6" base frame for the purpose of mounting units to a housekeeping pad and providing additional height to properly trap condensate from the unit. The integral base frame may be used for ceiling suspension, external isolation, or as a housekeeping pad. Each indoor unit section will be shipped with 4 lifting lugs for proper lift and installation. Indoor units will be shipped with a shipping skid designed for forklift transport.

Per ASHRAE 62.1 recommendation, indoor air handling units will be shipped stretch-wrapped to protect unit from in-transit rain and debris.

Installing contractor is responsible for long term storage in accordance with the Installation, Operation, and Maintenance manual (CLCH-SVX009*-EN).

Where applicable air-handling performance data shall be certified in accordance with AHRI Standard 430. This standard applies to Supply Fan ratings for Central Station Air-handling Units with Plenum Fans in a cabinet, Fan Arrays, Housed Centrifugal Fans, Axial Fans and includes direct drive plenum fans incorporated with ECM style motors.

Refer to product data for AHRI certification status. Propylene glycol and calcium chloride, or mixtures thereof, are outside the scope of AHRI Standard 410 and, therefore, do not require AHRI rating or certification. For coils within the scope of AHRI Standard 410 cooling coil performance is certified in accordance with the AHRI Forced-Circulation Air-Cooling and Air-Heating Coils Certification Program which is based on AHRI Standard 410 within the Range of Standard Rating Conditions listed in Table 1 of the Standard. Certified units may be found in the AHRI Directory at www.ahridirectory.org. Heating performance for heat pump or condenser mode is not certified.

Unit Construction**Casing Construction**

All unit panels shall be 2-inch solid, double-wall construction to facilitate cleaning of unit interior. All exterior and interior AHU panels will be made of galvanized steel. Motor and drive locations can be on the same side as the unit coil connections or on the opposite side. The casing shall be able to withstand up to 6" w.g. positive or negative static pressure. The unit panels shall not exceed .005 inch deflection per inch of panel span at 6" w.g. positive or negative static pressure. Casing construction will comply with NFPA 90A.

Floor Construction

The unit floor shall be of sufficient strength to support a 300.0 lb load during maintenance activities and shall deflect no more than .005 inch per inch of panel span when sitting on a support structure.

Insulation

Panel insulation shall provide a minimum thermal resistance (R) value of 13 ft²*h*°F/Btu throughout the entire unit. Insulation shall completely fill the panel cavities in all directions so that no voids exist and settling of insulation is prevented.

Drain Pan

All units shall be provided with an insulated assembly of either polymer material or stainless steel. Refer to the Product Data section of the submittal for the drain pan material. To address indoor air quality (IAQ), the drain pan shall be designed in accordance with ASHRAE 62.1 being of sufficient size to collect all condensation produced from the coil and sloped in two planes promoting positive drainage to eliminate stagnant water conditions. The outlet shall be located at the lowest point of the pan and shall be sufficient diameter to preclude drain pan overflow under any normally expected operating condition. All drain pan connections shall be visible external to the unit.

Access Door Construction

Access doors shall be 2-inch double-wall construction. Interior and exterior door panels shall be of the same construction as the interior and exterior wall panels, respectively. Surface-mounted handles shall be provided to allow quick access to the interior of the unit. Handle hardware shall be designed to prevent unintended closure. Outswing doors shall have easily removable hinges and handles that can be relocated to change the door swing if needed. Door hinges shall be made of galvanized steel.

Filters

2-inch pleated media filters made with 100% synthetic fibers that are continuously laminated to a supported steel-wire grid with water repellent adhesive shall be provided. Filters shall be capable of operating up to 625 fpm face velocity without loss of filter efficiency and holding capacity. The filters shall have a MERV 8 rating when tested in accordance with the ANSI/ASHRAE Standard 52.2.

COIL SECTION

The coil section shall be provided complete with coil holding frame. No coil shall be provided by the unit manufacturer.

Access Section with Coil

Unit(s) shall include a separate section housing a coil section and access section as one assembly. Refer to drawings to determine which unit(s) include the additional section. Section shall include either a polymer or stainless steel drainpan, refer to the Product Data section of the submittal for the drain pan material, and an access door of sufficient size to allow for visual inspection of the leaving face of the first coil in the airstream (if ordered) and entering face of the second coil in the airstream (if ordered). Access door shall be of the same construction as all other doors on the unit.

Electric Heat:

A UL-recognized electric heater shall be factory-installed in the air handler. The electric heat is an open-wire resistance heater and installed in the reheat position. The heater has primary and secondary protection circuits. The contactors for energizing the electric heater shall be magnetic contactors. Electric heaters above 48 amps shall be fused into circuits not to exceed 48 amps as required by UL and NEC.

SSR-Full Modulating Control (0-10 VDC)

The electric heater shall be factory-wired to accommodate SSR-Full Modulating control. The SSR control can receive a 0-10VDC signal from a standalone thermostat or building automation system providing full modulating control of the heater.

Fans selected with shaft grounding shall have a maintenance free grounding assembly installed on the fan motor to discharge both static and induced shaft currents to ground.

DIRECT-DRIVE PLENUM FAN SECTION

The fan shall be a single-width, single-inlet, 10-bladed direct-drive plenum fan. The fan shall consist of a backward-curved, welded steel wheel. Motor bearing life of the direct-drive plenum fan shall be not less than L-10 250,000 hrs. Units containing multiple fans shall be controlled using a common control signal, such as the duct static control signal, to modulate the fan speed.

Motor Frame

The motor shall be mounted integral to the isolated fan assembly and furnished by the unit manufacturer. The motor is mounted inside the unit casing on an adjustable base to permit adjustment of drive belt tension (not applicable for direct drive plenum fans). The motor shall meet or exceed all NEMA Standards Publication MG 1 requirements and comply with NEMA Premium efficiency levels when applicable except for fractional horsepower motors which are not covered by the NEMA classification. The motor shall be T-frame, squirrel cage with size, type, and electrical characteristics as shown on the equipment schedule. *Refer to the Product Data section for selected fan motors within each unit.*

Fan Isolation

Belt driven housed fans and direct drive plenum fans with integral frame motors shall be internally isolated to inhibit noise and vibration through the ductwork and building structure. A flexible connection shall be installed between the fan and unit casing to ensure complete isolation. Fan and motor shall be internally isolated with spring isolators. Flexible connection shall comply with NFPA 90A and UL 181 requirements.

Fan Discharge Temperature Sensor

A button or probe temperature sensor shall be mounted in the fan discharge.

VFD

A Variable Frequency Drive (VFD) shall be provided when variable air volume control is required for fan operation. Whether for single fan, or dual fan applications, a single VFD shall be provide to ensure proper operation and to optimize operating life. Each VFD shall be properly sized, factory mounted, wired to the fan motor, and commissioned to facilitate temporary heating, cooling, ventilation, and/or timely completion of the project. The VFD package shall also include:

- a) Electronic manual speed control
- b) Inlet fuses to provide maximum protection against inlet short circuit
- c) Current limited stall prevention
- d) Auto restart after momentary power loss
- e) Speed search for starting into rotating motor
- f) Anti-windmill w/DC injection before start
- g) Phase-to-phase short circuit protection
- h) Ground fault protection

Units with factory-mounted controls shall include power wiring from the VFD panel to the control system, binary output on/off wiring, analog output-speed-signal wiring, binary fault signal wiring and all interfacing wiring between the VFD and the direct control interface.

The VFD shall be covered by UL1995 Standards.

Field Programmable UC600

Factory-mounted direct digital control (DDC) system shall be engineered, mounted, wired and tested by the air handler manufacturer to reduce installed costs, improve reliability, and save time at unit startup. Each control system shall be fully functional in a stand-alone mode or may be tied to a building automation system with a single pair of twisted wires. All factory-mounted controls shall be covered by the air handler manufacturer's standard warranty. A dedicated, programmable, direct digital-controller with the appropriate point capabilities shall be unit-mounted on each air-handling unit.

Control panel to include a disconnect switch, motor current overload protection (if applicable), fused line voltage to 24 volt transformer, and three pole fan contactor. If a factory mounted VFD is provided on the supply fan, power wiring for the VFD shall come from the control distribution panel. Speed reference/signal control for the VFD shall be wired to the direct digital-controller.

DX Coil

The coils shall have aluminum fins, copper tubes, and dual intertwined circuits. The fins shall have collars drawn, belled, and firmly bonded to tubes by mechanical expansion of the tubes. The coil casing shall be galvanized steel. Suction and liquid line connections shall extend to the unit exterior.

Suction headers shall be constructed of copper tubing with connections penetrating unit casings to permit sweat connections to refrigerant lines. The coils shall have distributors sized according to the capacities of the coils.

Hot Gas Reheat Coil

The unit is factory equipped with modulating hot gas reheat. By diverting hot discharge gas to a coil in the supply air stream, approximately room neutral air will be delivered to the space.

Dimensional Drawings - Performance Climate Changer (UCCA)

Item: A1 Qty: 1 Tag(s): OAHU-1

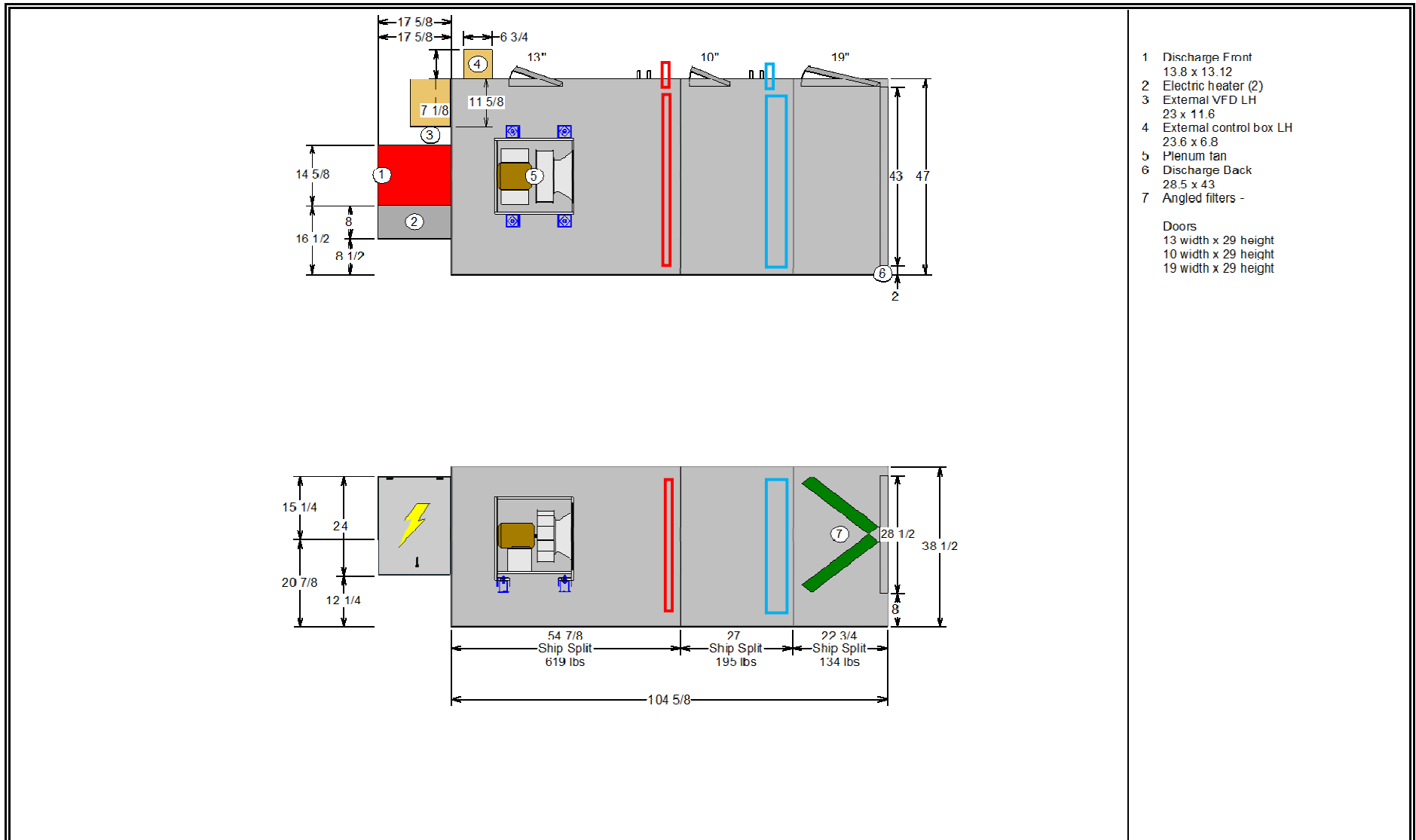

- 1 Discharge Front
13.8 x 13.12
 - 2 Electric heater (2)
 - 3 External VFD LH
23 x 11.6
 - 4 External control box LH
23.6 x 6.8
 - 5 Plenum fan
 - 6 Discharge Dack
28.5 x 43
 - 7 Angled filters -
- Doors
 13 width x 29 height
 10 width x 29 height
 19 width x 29 height

OPENING AND DIMENSIONS MAY VARY FROM CONTRACT DOCUMENTS / RETURN OF APPROVED DRAWINGS CONSTITUTES ACCEPTANCE OF THESE VARIANCES / NOT TO SCALE

Unit size: 6	Job Name: US Army Reserve Center Palatka FL	Unit Casing: 2in Double Wall Foam
Unit type: Indoor unit	Design airflow: 2100 cfm	Proposal Number
Pipe cab / curb / paint:	Sales Office	Tags: OAHU-1
		Rigging/Installed Weight: 947.2 lb / 947.2 lb



Dimensional Drawings - Performance Climate Changer (UCCA)

Item: A1 Qty: 1 Tag(s): OAHU-1

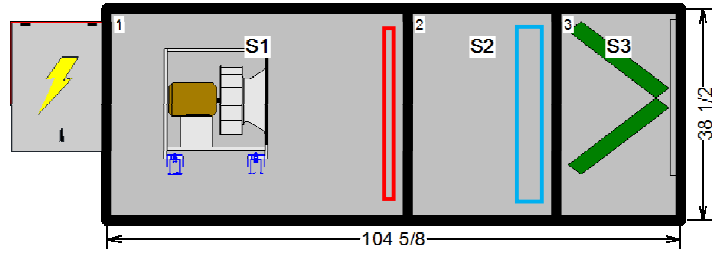

Pos #	Module	Length	Weight
1	Base Unit	54 7/8	659.00
2	Coil Access Section	27	294.70
3	Filter / mixing / econ section	22 3/4	133.50
			Installed Unit Weight 1087.2 lbs

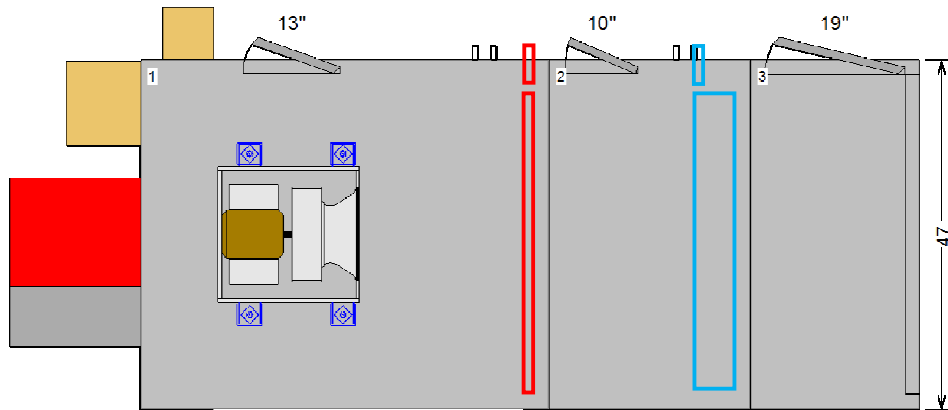

Basic Overall Plan View: Top - Measurements in inches

OPENING AND DIMENSIONS MAY VARY FROM CONTRACT DOCUMENTS / RETURN OF APPROVED DRAWINGS CONSTITUTES ACCEPTANCE OF THESE VARIANCES / NOT TO SCALE

Unit size: 6	Job Name: US Army Reserve Center Palatka FL	Unit Casing: 2in Double Wall Foam
Unit type: Indoor unit	Design airflow: 2100 cfm	Proposal Number
Pipe cab / curb / paint:	Sales Office	Tags: OAHU-1
		Rigging/Installed Weight: 947.2 lb / 947.2 lb



Dimensional Drawings - Performance Climate Changer (UCCA)

Item: A1 Qty: 1 Tag(s): OAHU-1

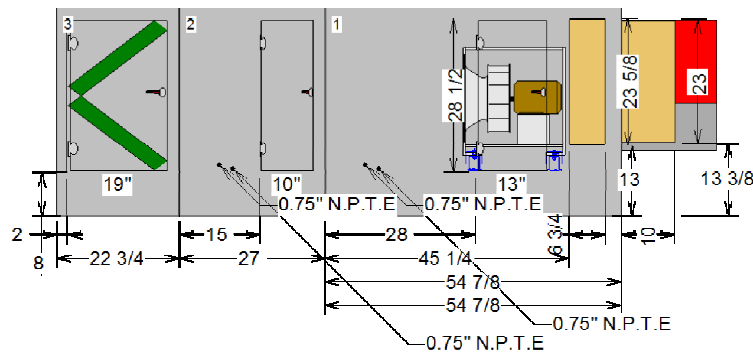
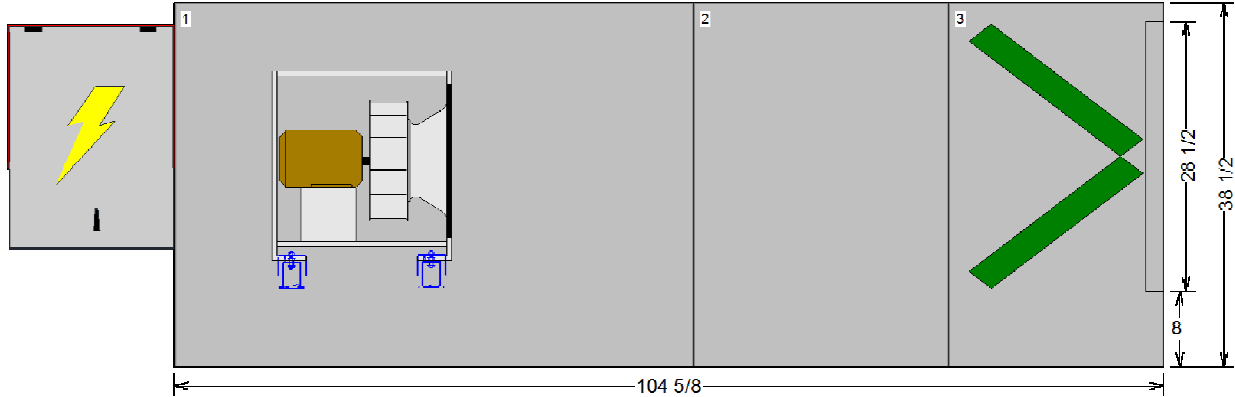

Detailed Elevation View: Left - Measurements in inches

OPENING AND DIMENSIONS MAY VARY FROM CONTRACT DOCUMENTS / RETURN OF APPROVED DRAWINGS CONSTITUTES ACCEPTANCE OF THESE VARIANCES / NOT TO SCALE

Unit size: 6	Job Name: US Army Reserve Center Palatka FL	Unit Casing: 2in Double Wall Foam
Unit type: Indoor unit	Design airflow: 2100 cfm	Proposal Number
Pipe cab / curb / paint:	Sales Office	Tags: OAHU-1
		Rigging/Installed Weight: 947.2 lb / 947.2 lb



Dimensional Drawings - Performance Climate Changer (UCCA)

Item: A1 Qty: 1 Tag(s): OAHU-1

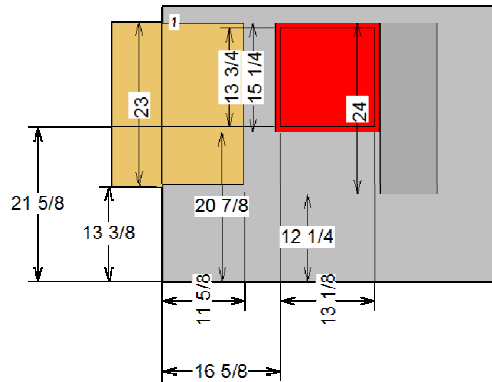

Detailed Elevation View: Front - Measurements in inches

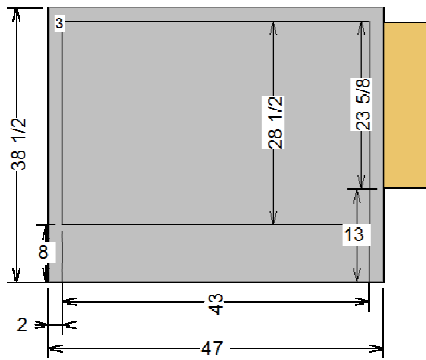

Detailed Elevation View: Back - Measurements in inches

OPENING AND DIMENSIONS MAY VARY FROM CONTRACT DOCUMENTS / RETURN OF APPROVED DRAWINGS CONSTITUTES ACCEPTANCE OF THESE VARIANCES / NOT TO SCALE

Unit size: 6	Job Name: US Army Reserve Center Palatka FL	Unit Casing: 2in Double Wall Foam
Unit type: Indoor unit	Design airflow: 2100 cfm	Proposal Number
Pipe cab / curb / paint:	Sales Office	Tags: OAHU-1
		Rigging/Installed Weight: 947.2 lb / 947.2 lb



Dimensional Drawings - Performance Climate Changer (UCCA)

Item: A1 Qty: 1 Tag(s): OAHU-1

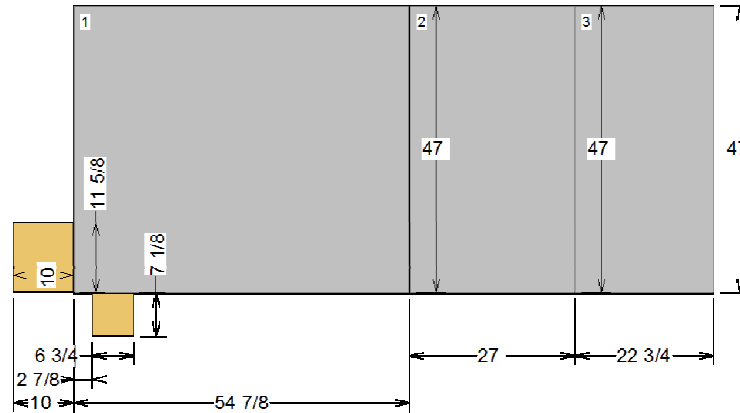

Left Side of Unit Detailed Plan View: Bottom - Measurements in inches

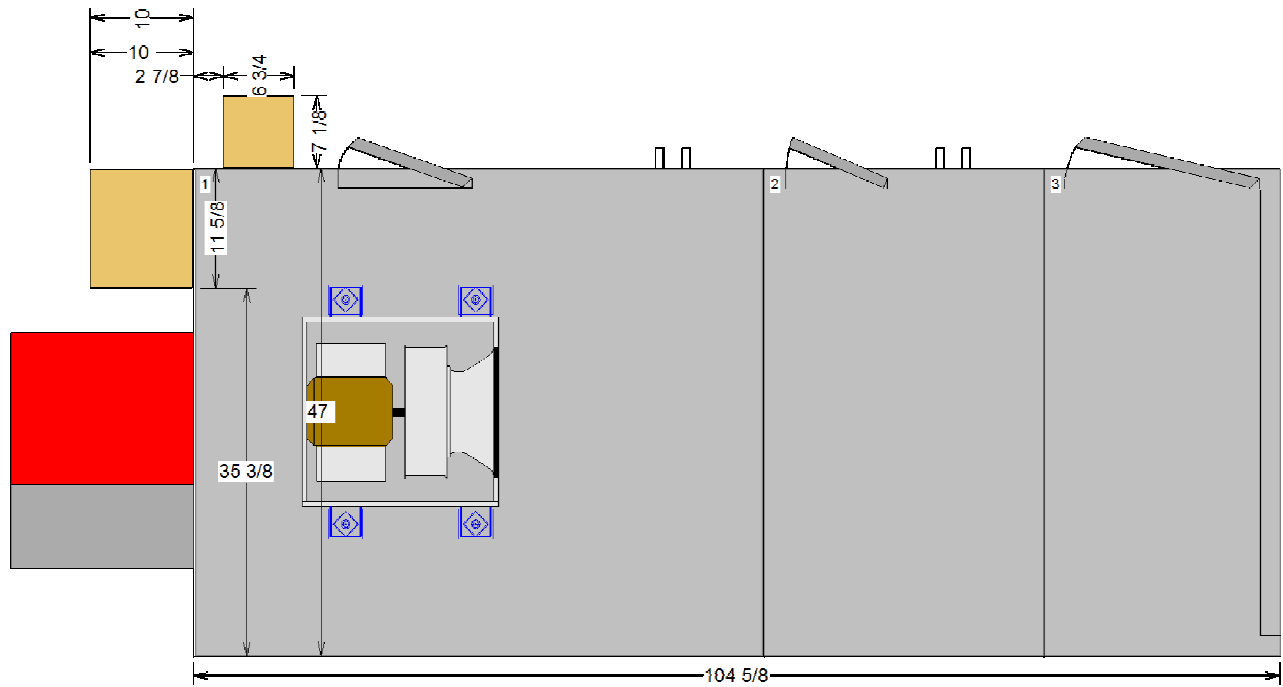

Right Side of Unit

Detailed Plan View: Top - Measurements in inches

OPENING AND DIMENSIONS MAY VARY FROM CONTRACT DOCUMENTS / RETURN OF APPROVED DRAWINGS CONSTITUTES ACCEPTANCE OF THESE VARIANCES / NOT TO SCALE

Unit size: 6	Job Name: US Army Reserve Center Palatka FL	Unit Casing: 2in Double Wall Foam
Unit type: Indoor unit	Design airflow: 2100 cfm	Proposal Number
Pipe cab / curb / paint:	Sales Office	Tags: OAHU-1
		Rigging/Installed Weight: 947.2 lb / 947.2 lb



Dimensional Drawings - Performance Climate Changer (UCCA)

Item: A1 Qty: 1 Tag(s): OAHU-1

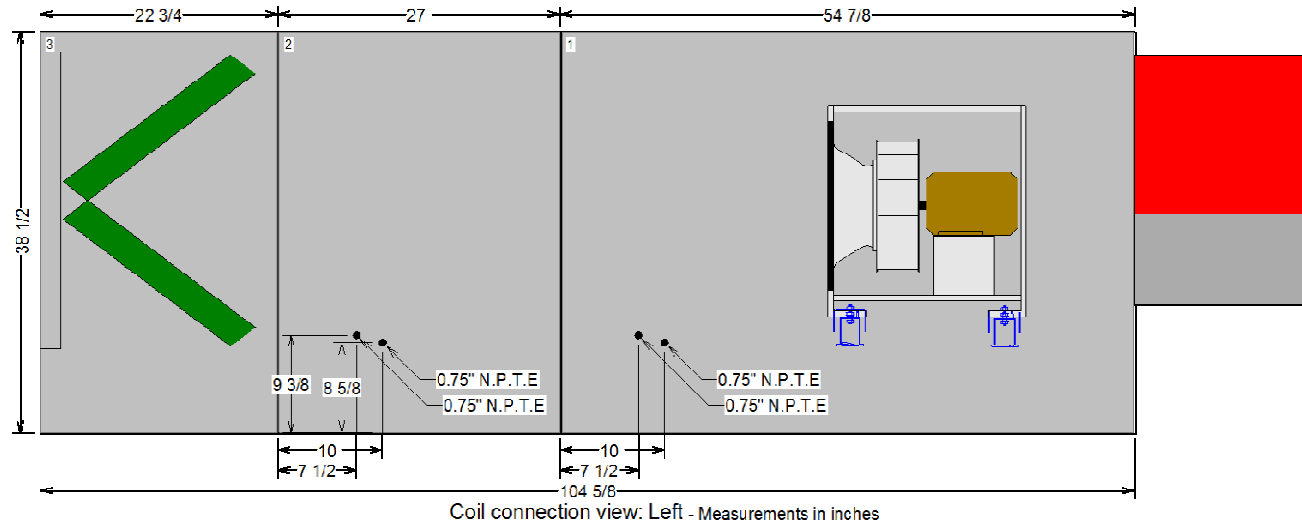

OPENING AND DIMENSIONS MAY VARY FROM CONTRACT DOCUMENTS / RETURN OF APPROVED DRAWINGS CONSTITUTES ACCEPTANCE OF THESE VARIANCES / NOT TO SCALE

Unit size: 6	Job Name: US Army Reserve Center Palatka FL	Unit Casing: 2in Double Wall Foam
Unit type: Indoor unit	Design airflow: 2100 cfm	Proposal Number
Pipe cab / curb / paint:	Sales Office	Tags: OAHU-1
		Rigging/Installed Weight: 947.2 lb / 947.2 lb



Dimensional Drawings - Performance Climate Changer (UCCA)

Item: A1 Qty: 1 Tag(s): OAHU-1

UCCA Indoor Service Clearances

Component		UNIT SIZE									
		3	6	8	10	12	14	17	21	25	30
Filter	A	40.0	44.0	42.0	42.0	40.0	45.0	45.0	45.0	51.0	51.0
Coil Pull	B	49.0	62.0	66.0	78.0	86.0	86.0	94.0	94.0	96.0	109.0
Fan Access, horizontal unit (motor side)	C	48.0	48.0	48.0	51.0	54.0	58.0	61.0	61.0	66.0	66.0
Fan Access, vertical unit (motor side)	C	48.0	48.0	48.0	51.0	54.0	58.0	61.0	61.0		
Fan Access, vert unit with MI fan (motor side)	C	48.0	48.0	48.0	51.0	54.0	58.0	61.0	61.0	66.0	66.0
Fan Access, return section (motor side)	C	48.0	48.0	48.0	51.0	54.0	58.0	61.0	61.0	66.0	66.0
Control Box	D	56.0	56.0	56.0	56.0	56.0	56.0	56.0	56.0	56.0	56.0
VFD	E	48.0	48.0	48.0	48.0	48.0	48.0	48.0	48.0	48.0	48.0
EH	F	48.0	48.0	48.0	48.0	48.0	48.0	48.0	48.0	48.0	48.0
Access Door - Access Section	G	15.0	15.0	15.0	15.0	15.0	15.0	15.0	15.0	15.0	15.0

Note(s):

At a minimum, the above clearance dimensions are recommended on one side of the unit for regular service and maintenance.

Clearances are mirrored to other side for units with doors both sides.

Refer to as-built submittal for locations of items such as filter access doors, coil, piping connections, motor locations, etc.

Sufficient clearance must be provided on all sides of unit for removal of access panels, plug panels, or section-to-section attachment brackets

Clearance for starters, VFD's, or other high-voltage devices must be provided per NEC requirements.

Service Clearances

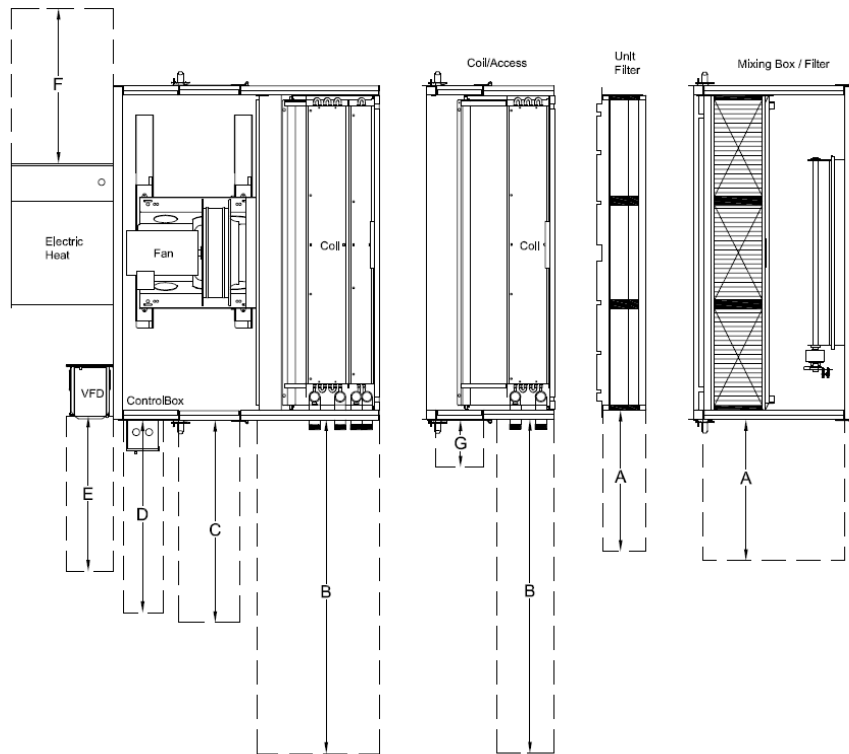

Dimensional Drawings - Performance Climate Changer (UCCA)

Item: A1 Qty: 1 Tag(s): OAHU-1

Drain pan trapping for negative pressure applications

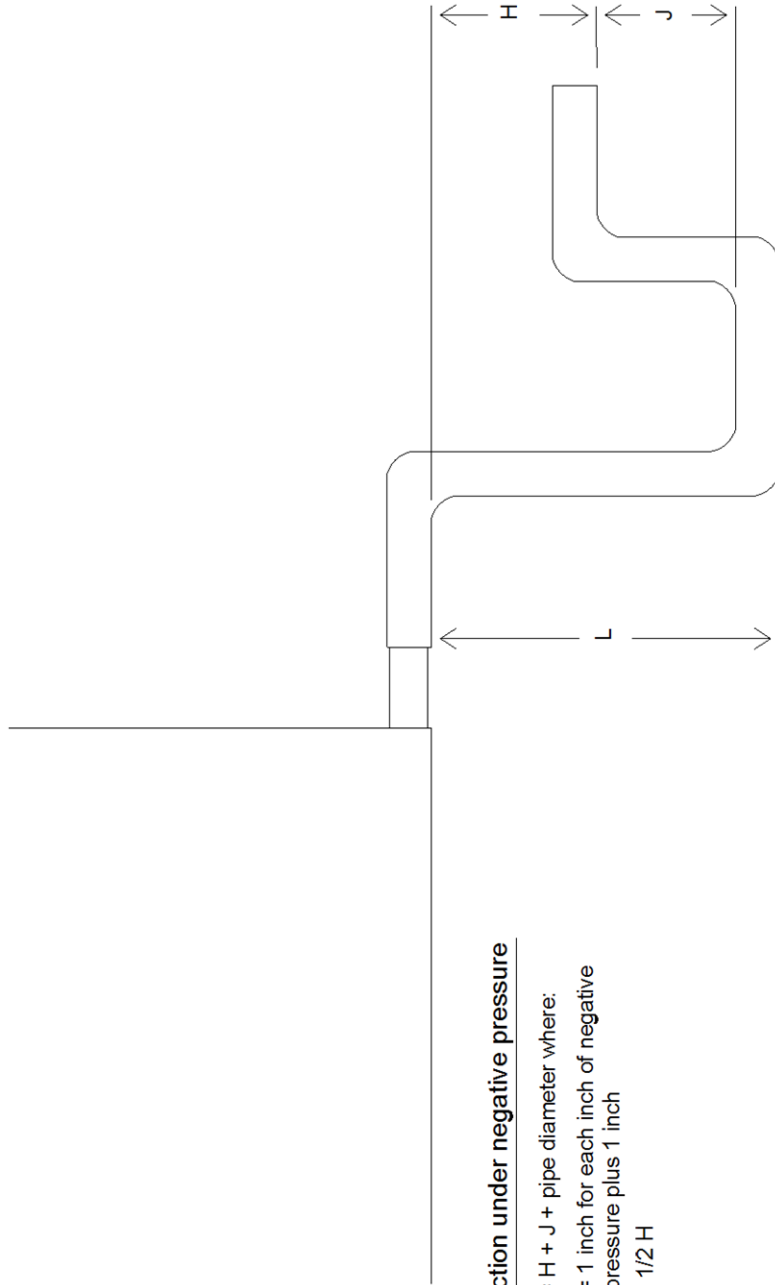

Section under negative pressure

- L = H + J + pipe diameter where:
- H = 1 inch for each inch of negative pressure plus 1 inch
- J = 1/2 H

Recommended Trap Dimensions			Connection Size
H	J	L	3/4"
See IOM	See IOM	See IOM	

To ensure proper condensate trapping the field installed housekeeping pad height is the responsibility of the contractor.
The external static pressure used for fan selection was assumed to be divided 50% to entering duct external static pressure and 50% discharge external static pressure.

Dimensional Drawings - Performance Climate Changer (UCCA)

Item: A1 Qty: 1 Tag(s): OAHU-1

Base Detail

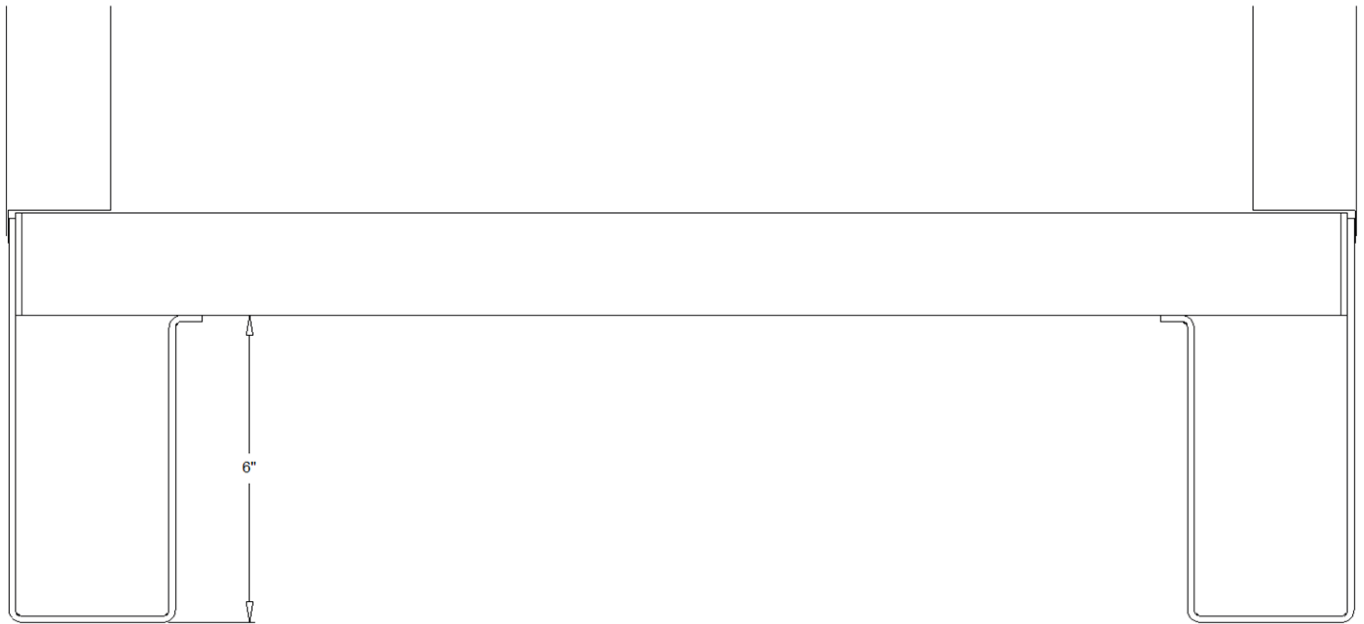

Fan Curve - Performance Climate Changer (UCCA)

Item: A1 Qty: 1 Tag(s): OAHU-1

Fan Details

Unit Size	6	Operating Brake Power	1.832 hp
Operating Airflow	2,100 cfm	Altitude	0.00 ft
Operating Static Pressure	2.856 in H2O	Design Temp.	80
Operating RPM	2,318 rpm		

5 % BHP margin applied for motor selection.

Size 6 DDP Front Top Discharge – Single Fan.

Size 6 DDP Front Top Discharge – Single Fan.

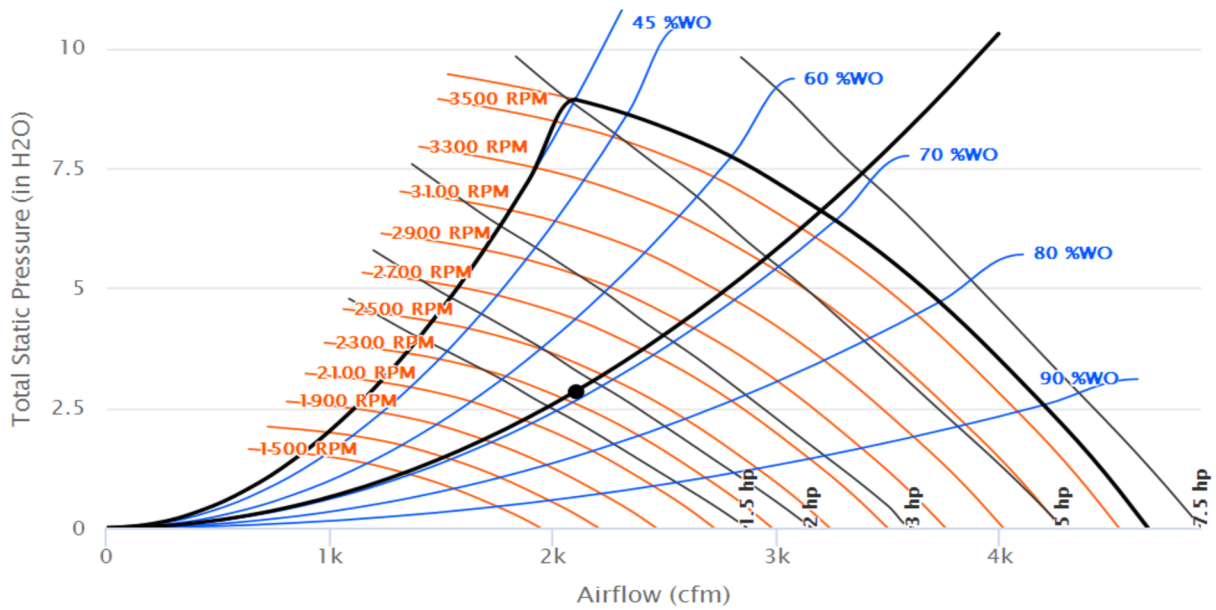

Accessory - Performance Climate Changer (UCCA)
 Item: A1 Qty: 1 Tag(s): OAHU-1

RETURN FAN 1 SCHEMATIC PAGE 1 OF 2

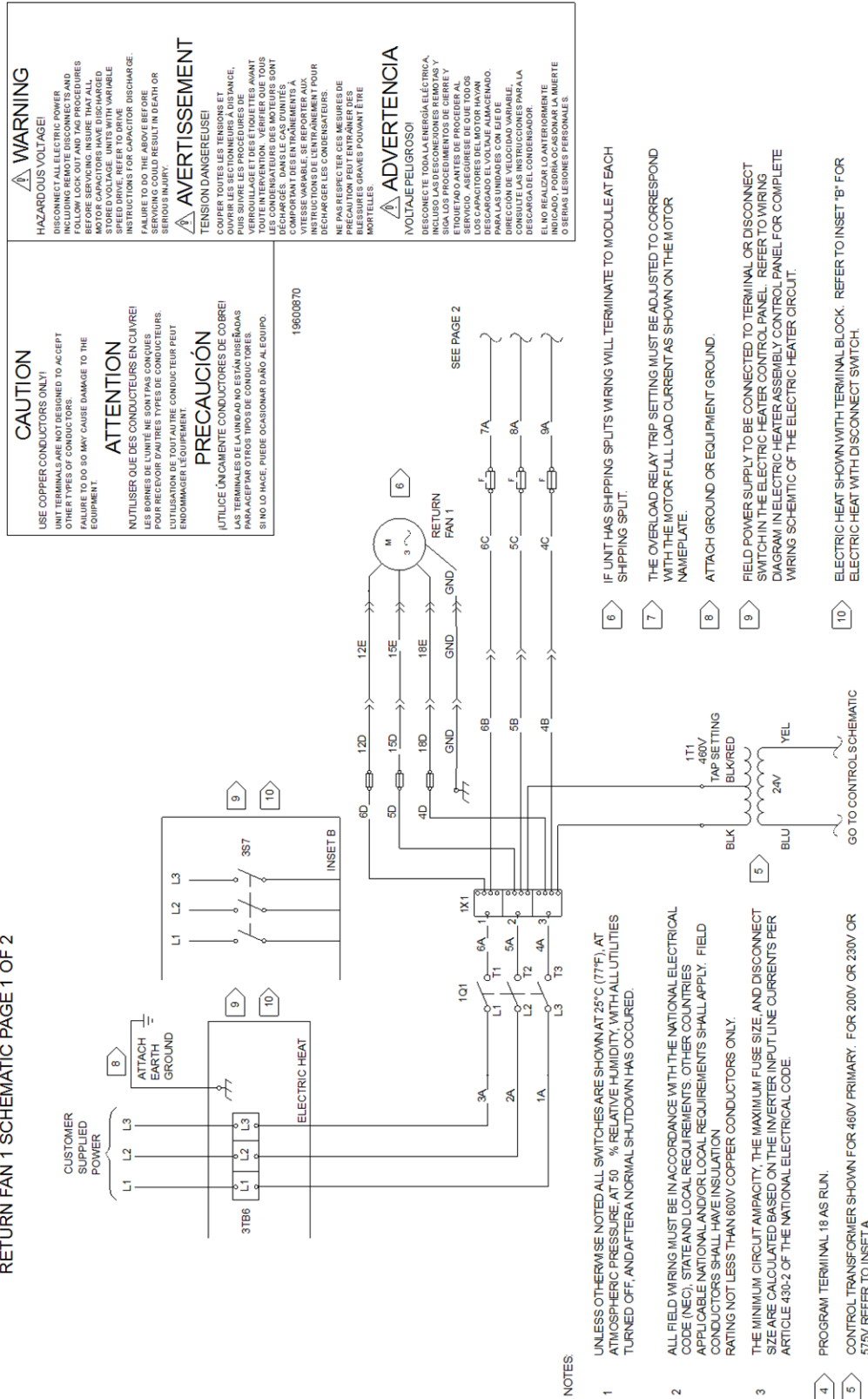

CAUTION
 USE COPPER CONDUCTORS ONLY!
 UNIT TERMINALS ARE NOT DESIGNED TO ACCEPT OTHER TYPES OF CONDUCTORS.
 FAILURE TO DO SO MAY CAUSE DAMAGE TO THE EQUIPMENT.

ATTENTION
 N'UTILISER QUE DES CONDUCTEURS EN CUIVRE!
 LES BORNES DE L'UNITÉ NE SONT PAS CONÇUES POUR RECEVOIR D'AUTRES TYPES DE CONDUCTEURS.
 L'UTILISATION DE TOUT AUTRE CONDUCTEUR PEUT ENDOMMAGER L'ÉQUIPEMENT.

PRECAUCIÓN
 ¡UTILICE ÚNICAMENTE CONDUCTORES DE COBRE!
 LAS TERMINALES DE LA UNIDAD NO ESTÁN DISEÑADAS PARA ACEPTAR OTROS TIPOS DE CONDUCTORES.
 SI NO LO HACE, PUEDE OCASIONAR DAÑO AL EQUIPO.

WARNING
 HAZARDOUS VOLTAGE!
 DISCONNECT ALL ELECTRIC POWER INCLUDING REMOTE DISCONNECTS AND FOLLOW LOCK-OUT AND TAG PROCEDURES BEFORE WORKING ON THIS UNIT. INSURE ALL MOTOR CONDUCTORS ARE PROPERLY ISOLATED FROM ALL ENERGIZED PARTS OF THE UNIT. ALWAYS USE THE CORRECT SPEED DRIVE. REFER TO DRIVE INSTRUCTIONS FOR CAPACITOR DISCHARGE. FAILURE TO DO THE ABOVE BEFORE WORKING ON THIS UNIT MAY RESULT IN DEATH OR SERIOUS INJURY.

AVERTISSEMENT
 TENSION DANGEREUSE!
 COUPER TOUTES LES TENSIONS ET OUVRIR LES SECTIONNEURS À DISTANCE, SUIVANT LES PROCÉDURES DE VERROUILLAGE ET DES ÉTIQUETTES AVANT TOUTE INTERVENTION. VÉRIFIER QUE TOUTS LES CONDENSATEURS DES MOTEURS SONT DÉCHARGÉS AVANT TOUT TRAVAIL À COMPORTANT DES ENTRETIENNELS À VITESSE VARIABLE. SE REPORTER AUX INSTRUCTIONS DE L'ENTRAÎNEMENT POUR DÉCHARGER LES CONDENSATEURS. NE PAS TRAVAILER SUR LES UNITÉS AVANT D'ÊTRE SÛR QUE LES CONDENSATEURS SONT DÉCHARGÉS. LE NON-RESPECT DE CES PRÉCAUTIONS PEUT CAUSER LA MORT OU DES BLESSURES GRAVES POUVANT ÊTRE MORTELLES.

ADVERTENCIA
 ¡VOLTAJE PELIGROSO!
 DESCONECTE TODA LA ENERGÍA ELÉCTRICA, INCLUIDOS LOS SECCIONNEURS Y SIGA LOS PROCEDIMIENTOS DE CERRER Y ETIQUETAR ANTES DE PROCEDER AL SERVICIO. ASEGURESE DE QUE TODOS LOS CONDENSADORES DE LOS MOTORES ESTÉN DESCARGADOS EL VOLTAJE ALMACENADO. PARA LAS UNIDADES CON ELE DE DIRECCIÓN DE VELOCIDAD VARIABLE, REFERIRSE A LAS INSTRUCCIONES PARA LA DESCARGA DEL CONDENSADOR. EL NO REALIZARLO ANTERIORMENTE INDICADO, PODRÍA OCASIONAR LA MUERTE O SERIAS LESIONES PERSONALES.

19600870

SEE PAGE 2

- 6 IF UNIT HAS SHIPPING SPLITS WIRING WILL TERMINATE TO MODULE AT EACH SHIPPING SPLIT.
- 7 THE OVERLOAD RELAY TRIP SETTING MUST BE ADJUSTED TO CORRESPOND WITH THE MOTOR FULL LOAD CURRENT AS SHOWN ON THE MOTOR NAMEPLATE.
- 8 ATTACH GROUND OR EQUIPMENT GROUND.
- 9 FIELD POWER SUPPLY TO BE CONNECTED TO TERMINAL OR DISCONNECT SWITCH IN THE ELECTRIC HEATER CONTROL PANEL. REFER TO WIRING DIAGRAM IN ELECTRIC HEATER ASSEMBLY CONTROL PANEL FOR COMPLETE WIRING SCHEMATIC OF THE ELECTRIC HEATER CIRCUIT.
- 10 ELECTRIC HEAT SHOWN WITH TERMINAL BLOCK. REFER TO INSET "B" FOR ELECTRIC HEAT WITH DISCONNECT SWITCH.

- NOTES**
- 1 UNLESS OTHERWISE NOTED ALL SWITCHES ARE SHOWN AT 25°C (77°F) AT ATMOSPHERIC PRESSURE AT 50 % RELATIVE HUMIDITY. WITH ALL UTILITIES TURNED OFF, AND AFTER A NORMAL SHUTDOWN HAS OCCURRED.
 - 2 ALL FIELD WIRING MUST BE IN ACCORDANCE WITH THE NATIONAL ELECTRICAL CODE (NEC), STATE AND LOCAL REQUIREMENTS. OTHER COUNTRIES' APPLICABLE NATIONAL AND/OR LOCAL REQUIREMENTS SHALL APPLY. FIELD CONDUCTORS SHALL HAVE INSULATION RATING NOT LESS THAN 600V COPPER CONDUCTORS ONLY.
 - 3 THE MINIMUM CIRCUIT AMPACITY, THE MAXIMUM FUSE SIZE, AND DISCONNECT SIZE ARE CALCULATED BASED ON THE INVERTER INPUT LINE CURRENTS PER ARTICLE 430.2 OF THE NATIONAL ELECTRICAL CODE.
 - 4 PROGRAM TERMINAL 18 AS RUN.
 - 5 CONTROL TRANSFORMER SHOWN FOR 460V PRIMARY. FOR 200V OR 230V OR 575V REFER TO INSET A.

Accessory - Performance Climate Changer (UCCA)
Item: A1 Qty: 1 Tag(s): OAHU-1

RETURN FAN 1 SCHEMATIC PAGE 2 OF 2

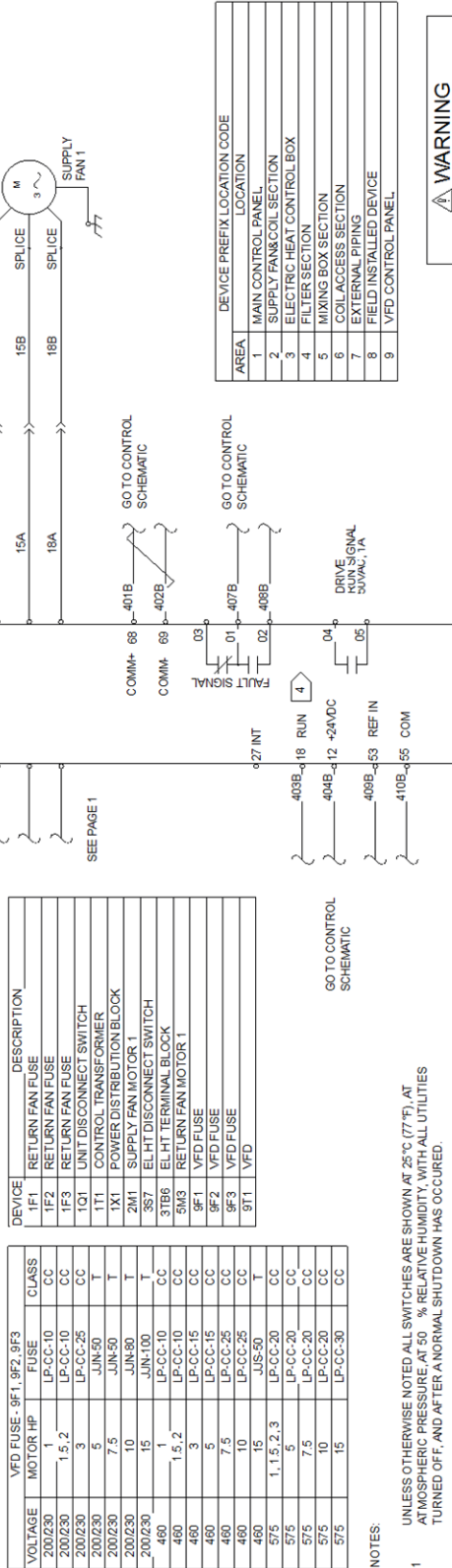

AREA	DEVICE PREFIX	LOCATION CODE	LOCATION
1	MAIN CONTROL PANEL		
2	SUPPLY FAN COIL SECTION		
3	ELECTRIC HEAT CONTROL BOX		
4	FILTER SECTION		
5	MIXING BOX SECTION		
6	COIL ACCESS SECTION		
7	EXTERNAL PIPING		
8	FIELD INSTALLED DEVICE		
9	VFD CONTROL PANEL		

HAZARDOUS VOLTAGE!
DO NOT TOUCH ELECTRICAL COMPONENTS INCLUDING REMOTE DISCONNECTS AND FOLLOW LOCK-OUT AND TAG PROCEDURES BEFORE SERVICING. INSURE THAT ALL STORED VOLTAGE UNITS WITH VARIABLE SPEED DRIVE REFER TO DRIVE INSTRUCTIONS FOR RECHARGE FAILURE TO DO THE ABOVE BEFORE SERVICING COULD RESULT IN DEATH OR SERIOUS INJURY.

AVERTISSEMENT
TENSION DANGEREUSE!
NE PAS TOUCHER LES TENSION ET OUVRIRES LES SECTIONNERS A DISTANCE. PUIS SUIVRE LES PROCEDURES DE SERRAGE. ASSUREZ-VOUS QUE TOUS LES CONDENSATEURS DES MOTEURS SONT DÉCHARGÉS AVANT DE COMMENCER LE TRAVAIL. CONSULTER LES INSTRUCTIONS À L'ÉLÉMENT VITESSE VARIABLE. SE REPORTER AUX INSTRUCTIONS POUR RECHARGER LES CONDENSATEURS AVANT DE COMMENCER LE TRAVAIL. NE PAS RESPECTER CES MESURES DE PRÉCAUTION PEUT ENTRAINER DES BLESSURES GRAVES POUVANT ÊTRE FATALES.

ADVERTENCIA
¡VOLTAJE PELIGROSO!
DESCONECTE TODA LA ENERGÍA ELÉCTRICA, INCLUIDO LAS RESISTENCIAS PRIMARIAS Y SECUNDARIAS, ANTES DE SERVICIAR. VERIFIQUE QUE TODOS LOS CONDENSADORES DE LOS MOTORES SE DESCARGAN ANTES DE EMPEZAR EL SERVICIO. ASEGURESE QUE TODOS LOS CONDENSADORES DE LOS MOTORES SE DESCARGAN EL VOLTAJE ALMACENADO ANTES DE EMPEZAR EL SERVICIO. CONSULTAR LAS INSTRUCCIONES PARA LA DESCARGA DEL CONDENSADOR ANTES DE EMPEZAR EL SERVICIO. EL NO REALIZAR LO ANTERIORMENTE PODRÍA CAUSAR LESIONES PERSONALES O SERIAS.

CAUTION
USE COPPER CONDUCTORS ONLY!
OTHER TYPES OF CONDUCTORS WHEN USED TO ACCEPT FAILURE TO DO SO MAY CAUSE DAMAGE TO THE EQUIPMENT.

ATTENTION
N'UTILISER QUE DES CONDUCTEURS EN CUivre!
D'AUTRES TYPES DE CONDUCTEURS LORSQU'ILS SONT UTILISÉS POUR ACCEPTER LA CHUTE DE TENSION PEUT ENDOMMAGER L'ÉQUIPEMENT.

PRECAUCIÓN
¡UTILICE ÚNICAMENTE CONDUCTORES DE COBRE!
PARA ACEPTAR OTROS TIPOS DE CONDUCTORES SIN LO HACER, PUEDE OCASIONAR DAÑO AL EQUIPO.

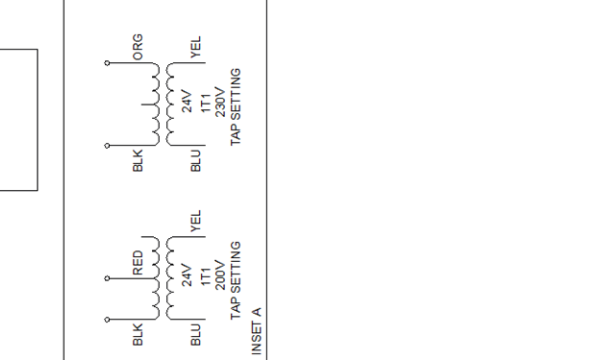

- UNLESS OTHERWISE NOTED ALL SWITCHES ARE SHOWN AT 25°C (77°F), AT ATMOSPHERIC PRESSURE, AT 50 % RELATIVE HUMIDITY, WITH ALL UTILITIES TURNED OFF, AND AFTER A NORMAL SHUTDOWN HAS OCCURRED.
- ALL FIELD WIRING MUST BE IN ACCORDANCE WITH THE NATIONAL ELECTRICAL CODE (NEC), STATE AND LOCAL REQUIREMENTS. OTHER COUNTRIES APPLICABLE NATIONAL AND/OR LOCAL REQUIREMENTS SHALL APPLY. FIELD CONDUCTORS SHALL HAVE INSULATION RATING NOT LESS THAN 600V COPPER CONDUCTORS ONLY.
- THE MINIMUM CIRCUIT AMPACITY, THE MAXIMUM FUSE SIZE, AND DISCONNECT SIZE ARE CALCULATED BASED ON THE INVERTER INPUT LINE CURRENT S PER ARTICLE 430.2 OF THE NATIONAL ELECTRICAL CODE.
- PROGRAM TERMINAL 18 AS RUN.
- CONTROL TRANSFORMER SHOWN FOR 480V PRIMARY. FOR 200V OR 230V OR 575V REFER TO INSET A.
- IF UNIT HAS SHIPPING SPLITS WIRING WILL TERMINATE TO MODULE AT EACH SHIPPING SPLIT.
- THE OVERLOAD RELAY TRIP SETTING MUST BE ADJUSTED TO CORRESPOND WITH THE MOTOR FULL LOAD CURRENT AS SHOWN ON THE MOTOR NAMEPLATE.
- ATTACH GROUND OR EQUIPMENT GROUND.
- FIELD POWER SUPPLY TO BE CONNECTED TO TERMINAL OR DISCONNECT SWITCH IN THE ELECTRIC HEATER CONTROL PANEL. REFER TO WIRING DIAGRAM IN ELECTRIC HEATER ASSEMBLY CONTROL PANEL FOR COMPLETE WIRING SCHEMATIC OF THE ELECTRIC HEATER CIRCUIT.
- ELECTRIC HEAT WITH DISCONNECT BLOCK. REFER TO INSET 'B' FOR ELECTRIC HEAT WITH DISCONNECT SWITCH.

Accessory - Performance Climate Changer (UCCA)

Item: A1 Qty: 1 Tag(s): OAHU-1

NOTES:

- 1. HEATER IS FACTORY MOUNTED IMMEDIATELY DOWNSTREAM OF THE SUPPLY FAN DISCHARGE.
- 2. HEATER WILL BE WIRED TO UNIT CONTROL BOX.
- 3. RIGHT HAND HEATER SHOWN. LEFT HAND HEATER IS MIRROR IMAGE OF RIGHT HAND.
- 4. ARROW INDICATES THE DIRECTION OF AIRFLOW.

ELECTRIC HEAT SECTION

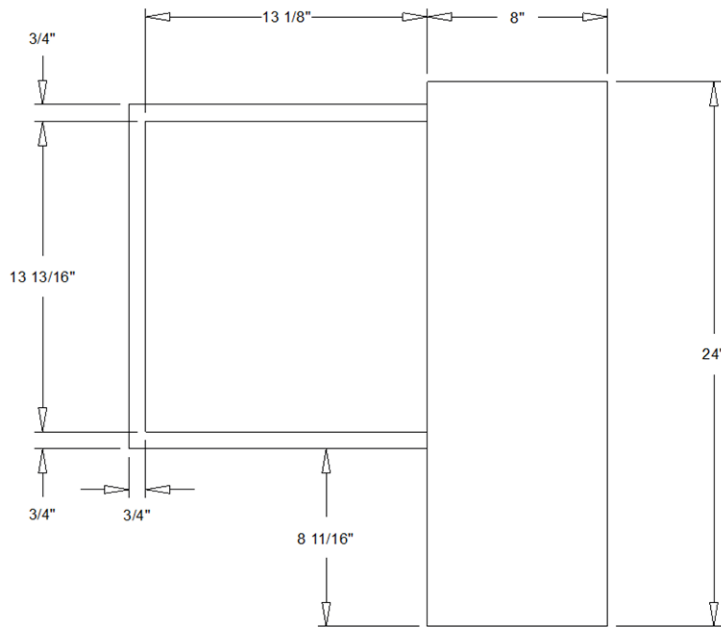

FRONT VIEW

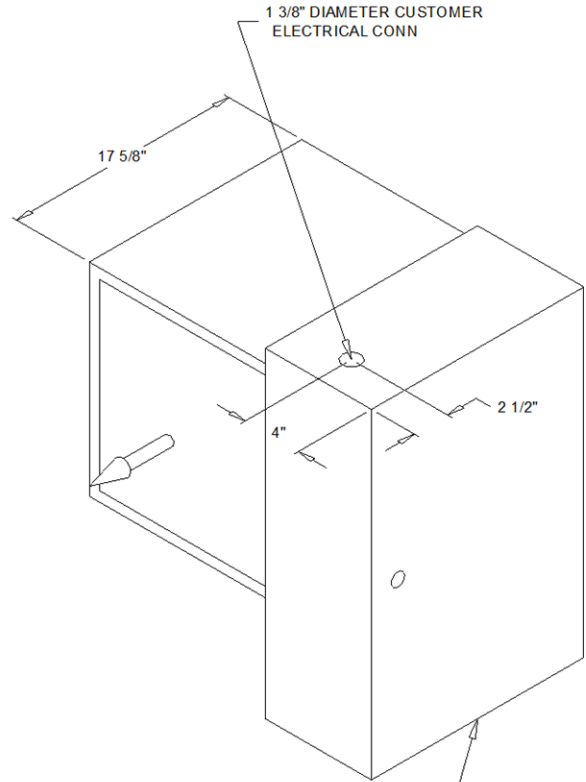

ISO1 VIEW

Accessory - Performance Climate Changer (UCCA)
 Item: A1 Qty: 1 Tag(s): OAHU-1

Discharge Air Sensor

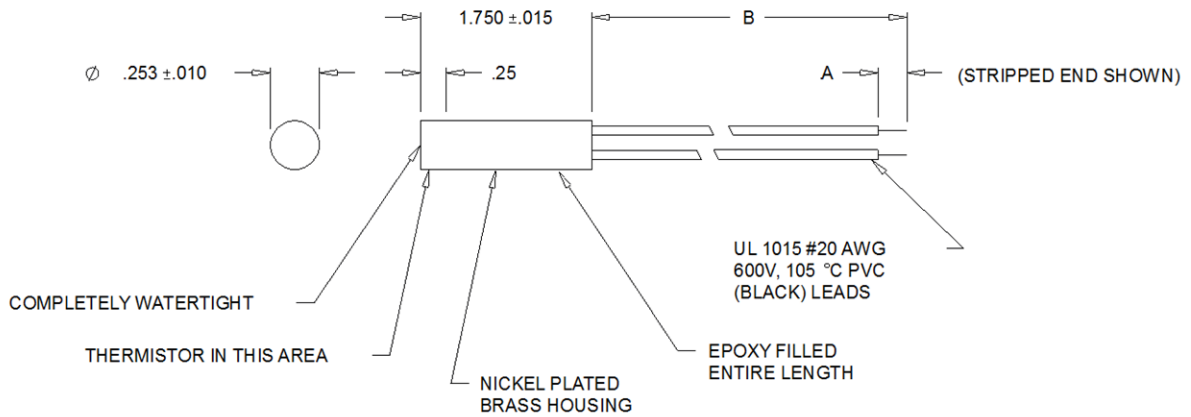

RESISTANCE TEMPERATURE CHARACTERISTICS			
TEMPERATURE	RESISTANCE		TEMP COEFF
	MIN	MAX	
-40 °C	320.9K	369.0K	-6.61%/ °C
-25 °C	125.6K	142.3K	-6.04%/ °C
0 °C	31.17K	34.6K	-5.16%/ °C
25 °C	9.56K	10.44K	-4.40%/ °C
65 °C	2.012K	2.158K	-3.50%/ °C

EXT	A	B
01	PLUG; AMP #172165-1 TERMINAL; PIN AMP #171638-1 (2 REQD)	16 ±.25

Accessory - Performance Climate Changer (UCCA)

Item: A1 Qty: 1 Tag(s): OAHU-1

OA Temp Sensor

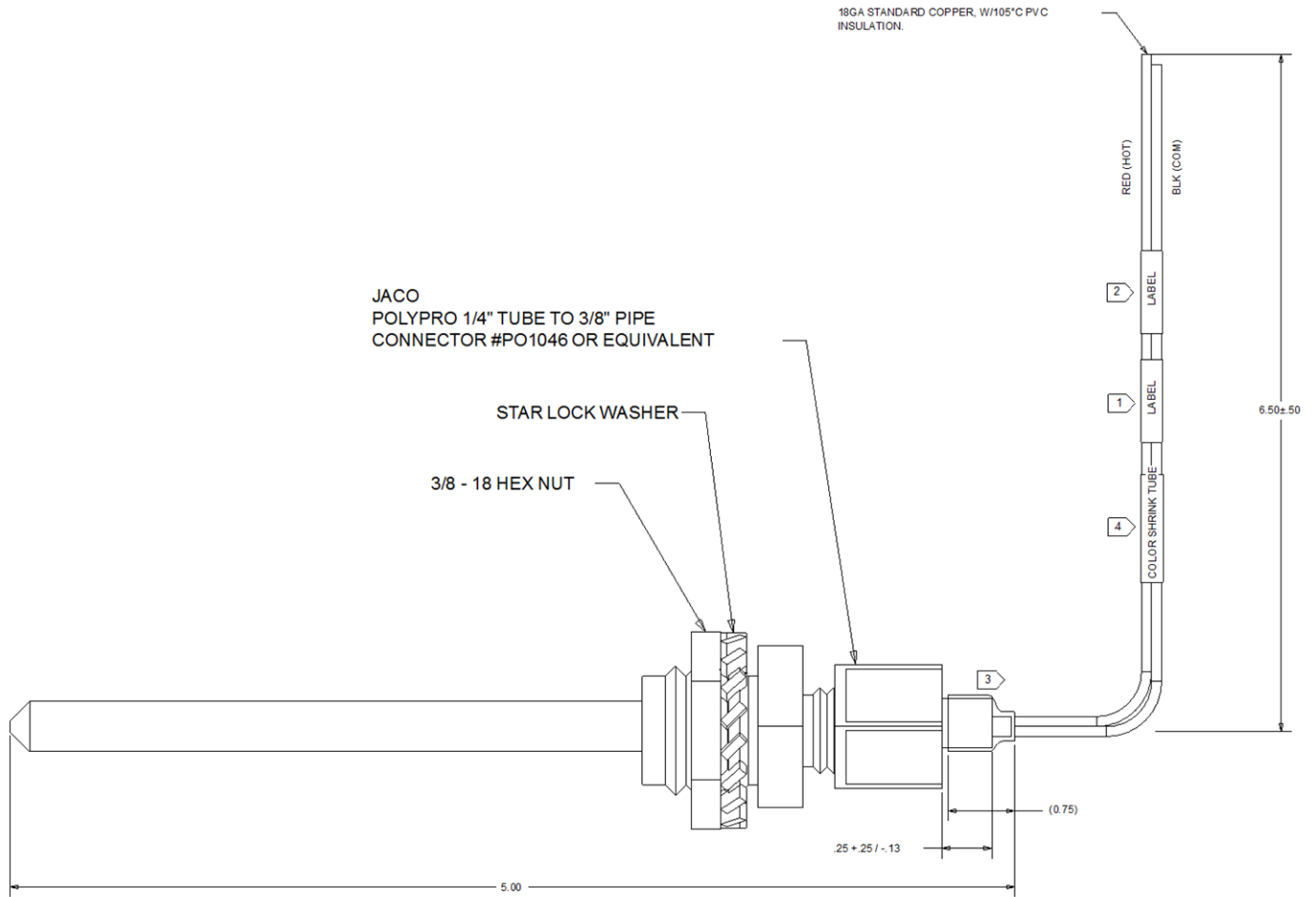

EXT	SENSOR RATING	BETA (0°C TO 50°C)	SHRINK TUBE COLOR	SENSOR
01	10,000 Ω TYPE II	3892K	YELLOW	THERMISTOR
02	10,000 Ω TYPE III	3575K	GREEN	
03	20,000 Ω TYPE IV	4140K	BLUE	
04	100,000 Ω TYPE II	3892K	GRAY	

EXT	SENSOR RATING	TCR	SHRINK TUBE COLOR	SENSOR
05	1,000 Ω PT 385	3850 PPM/K	WHITE	RTD
06	1,000 Ω NI-FE-JCI	6370 PPM/K	RED	
07	1,000 Ω NI-SIEMENS	5000 PPM/K	ORANGE	

Accessory - Performance Climate Changer (UCCA)

Item: A1 Qty: 1 Tag(s): OAHU-1

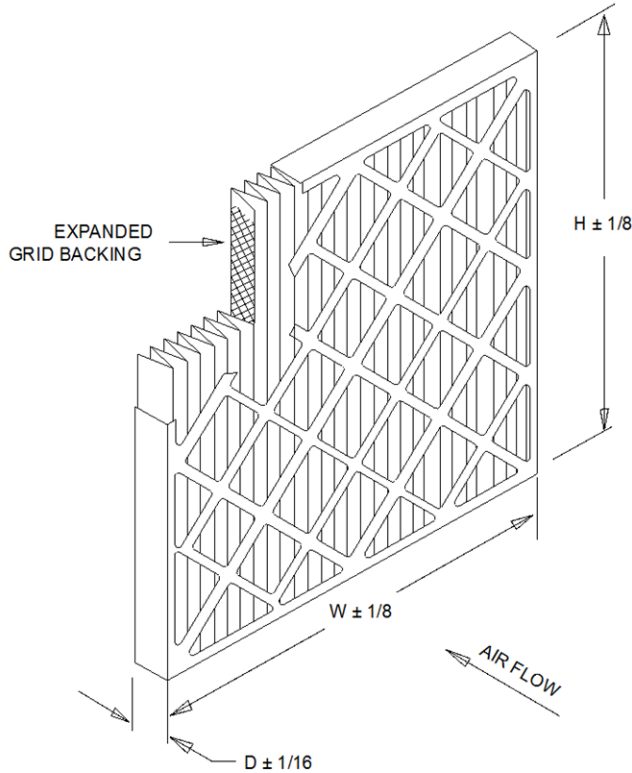

STANDARD CONSTRUCTION

1. 100 % Synthetic White Un-Dyed Media
2. 10.0 Pleats Per Foot
3. Expanded Metal Pleat Supports
4. Moisture Resistant Beverage Board Frame
5. Double Wall Frame

NOTES

1. MERV 8-A Per ASHRAE 52.2-2007 Appendix J.
2. Final Resistance: 1/0" W.G.
3. Rated Velocity: 500 FPM
4. Class 2 Filter Per U.L. Standard 900
5. Maximum Operating Temperature: 225 DEG. F

MODEL NUMBER	NOMINAL SIZE IN. W X H X D	ACTUAL SIZE IN. W X H X D	RATED AIR FLOW CFM	INITIAL RESISTANCE IN. W.G.	MEDIA AREA SQ. FT.
MX40-STD2-217	10 X 20 X 2	9-1/2 X 19-1/2 X 1-3/4	700	0.29	4.7
MX40-STD2-220	12 X 20 X 2	11-1/2 X 19-1/2 X 1-3/4	840	0.29	5.5
MX40-STD2-210	12 X 24 X 2	11-3/8 X 23-3/8 X 1-3/4	1000	0.29	6.2
MX40-STD2-239	14 X 20 X 2	13-1/2 X 19-1/2 X 1-3/4	980	0.29	5.7
MX40-2TD2-241	14 X 25 X 2	13-1/2 X 24-1/2 X 1-3/4	1220	0.29	7.1
MX40-STD2-245	15 X 20 X 2	14-1/2 X 19-1/2 X 1-3/4	1050	0.29	6.2
MX40-STD2-201	16 X 20 X 2	15-1/2 X 19-1/2 X 1-3/4	1120	0.29	6.7
MX40-STD2-216	16 X 24 X 2	15-3/8 X 23-3/8 X 1-3/4	1340	0.29	8.0
MX40-STD2-202	16 X 24 X 2	15-1/2 X 24-1/2 X 1-3/4	1400	0.29	8.0
MX40-STD2-280	15 X 20 X 2	17-1/2 X 19-1/2 X 1-3/4	1250	0.29	7.8
MX40-STD2-212	18 X 24 X 2	17-3/8 X 23-3/8 X 1-3/4	1500	0.29	9.3
MX40-STD2-285	18 X 25 X 2	17-1/2 X 24-1/2 X 1-3/4	1570	0.29	9.7
MX40-STD2-203	20 X 20 X 2	19-1/2 X 19-1/2 X 1-3/4	1400	0.29	8.3
MX40-STD2-211	20 X 24 X 2	19-3/8 X 23-3/8 X 1-3/4	1670	0.29	9.9
MX40-STD2-204	20 X 25 X 2	19-1/2 X 24-1/2 X 1-3/4	1750	0.29	10.3
MX40-STD2-205	24 X 24 X 2	23-3/8 X 23-3/8 X 1-3/4	2000	0.29	11.7
MX40-STD2-225	25 X 25 X 2	24-1/2 X 24-1/2 X 1-3/4	2170	0.29	13.6

Accessory - Performance Climate Changer (UCCA)**Filter Schedule****Item: A1 Qty: 1 Tag(s): OAHU-1**

Unit Tag(s)	Unit Size	Filter Arrangement	Filter Type \ MERV Rating	Filter Quantity	Filter Size
OAHU-1	Unit Size 6 Square Feet of Coil	2" angle filter section	2" MERV 8	0 0 4 0	16 in. x 20 in. 16 in. x 25 in. 20 in. x 20 in. 20 in. x 25 in.

Field Wiring - Performance Climate Changer (UCCA)**MCA - MOP Schedule****Item: A1 Qty: 1 Tag(s): OAHU-1**

Unit Tag(s)	Circuit	Circuit Description	Voltage/Phase/Hz	MCA (A)	MOP (A)
OAHU-1	1	SF Motor(s) + HV + CONT + EH	460/60/3	29.96	30.00

Tag Data - Odyssey Split System Outdoor Unit (Qty: 1)

Item	Tag(s)	Qty	Description	Model Number
B1	CU-1	1	6 - 25 Ton Unitary Split Systems Outdoor	TTA12043DAA**BS01000100000000000000000000

Product Data - Odyssey Split System Outdoor Unit

Item: B1 Qty: 1 Tag(s): CU-1

- Standard Ship Cycle
- Cooling (TTA)
- 10 Tons
- R-410A Refrigerant
- 208-230/60/3
- Dual Compressors / Dual Circuit
- Generation B (2023 DOE)
- Symbio (Cooling)
- STD Coil w/ Guards
- Advanced Controller - BACnet BAS (TTA)
- Ext. mount Small cabinets (Symbio) (Field Installed)
- Pressure Transducer for ICM (Field Installed)
- Service Valve accessory kit (Field Installed)
- 1st Year Labor Warranty Whole Unit

Additional Options:

- Digital Scroll Lead Compressor
 - Installed on 1st Circuit
- Modulating Hot Gas Reheat Valve
 - Installed on 2nd Circuit
- Symbio Dehumidification and Cooling Discharge Air Temperature Control
- Low Ambient Kit
- Discharge Air Temperature and Humidity Sensor (Fld)

Additional options are covered by TCS 1 year parts only warranty

Product Report - Odyssey Split System Outdoor Unit
Item: B1 Qty: 1 Tag(s): CU-1

6 - 25 Ton Unitary Split Systems Outdoor

Unit Overview	
Model	TTA12043DAA**BS0100010000000 000000000000
Unit Tonnage	10 Tons
Controls	Symbio (Cooling)
Unit Voltage	208-230/60/3
Refrigeration Circuit / Stage	Dual Compressors / Dual Circuit
Unit Function	Cooling
Max. Cond. Operating Weight	391.0 lb



Electrical Information			
MCA	43.00 A	Compressor 2 RLA	16.20 A
MOP	60.00 A	Cond. Motor 1 FLA	4.30 A
Compressor 1 RLA	17.90 A	Cond. Motor 2 FLA	0.00 A

Mechanical Specifications - Odyssey Split System Outdoor Unit
Item: B1 Qty: 1 Tag(s): CU-1**General - (TTA)**

- Weatherproofed steel mounting/lifting rails
- Hermetic scroll compressors
- Microchannel condenser coils
- Fans and motors
- Standard operating range 50.0 F-125.0 F (min. 0.0 F with low ambient accessory)
- Nitrogen holding charge

Casing - TTA

- Zinc coated, heavy gauge, galvanized steel
- Weather resistant baked enamel finish
- Meets ASTM B117, 672-hour salt spray test
- Removable single side maintenance access panels
- Lifting handles in maintenance access panels
- Unit base provisions for forklift and/or crane lifting

Refrigeration System - Dual Compressor (TTA0724*D, TTA0904*D, TTA1204*D, TTA1504*D, TTA1804*D, TTA2404*D)

- Two (2) separate and independent refrigerant circuits
- Each refrigeration circuit equipped with integral subcooling circuit
- Front or rear refrigerant line connections (TTA180**D/240**D)
- Two (2) direct drive hermetic scroll compressor
- Suction gas-cooled motors w/ \pm 10% voltage utilization range of unit nameplate voltage
- Crankcase Heaters
- Internal temperature and current sensitive motor overloads
- Factory installed liquid line filter driers
- Phase loss/reverse rotation monitor
- No compressor suction and/or discharge valves (reduced vibration/sound)
- External high pressure cutout devices
- External low pressure cutout devices
- Evaporator defrost control
- Loss of charge protection (discharge temperature limits)

Condenser Coil (Microchannel) - (TTA)

- Microchannel coils burst tested by the manufacturer
- Coils shall be leak tested to ensure the pressure integrity
- Factory pressure and leak tested to 660 psig

Condenser Fan - (TTA)

- 26" or 28" propeller fan(s)
- Direct drive
- Statically and dynamically balanced

Controls - (TTA)

- Centralized microprocessor
- Indoor and outdoor temperature sensors drive algorithms, making decisions for all heating, cooling, and ventilation
- Integrated anti-short cycle timer
- Integrated time delay between compressors
- Completely internally wired
- Colored and keyed connectors and colored wires
- Contactor pressure lugs or terminal block
- Unit external mounting location for disconnect device
- Single point power entry
- Front or rear electrical connections (TTA 1804*C/D, 2404*C/D, 3004*C only)

Note:

The 2-speed or SZVAV units should not be used with any single-speed, single-compressor condensing unit. The result of this selection will cause the SZVAV AHU to act as a CONSTANT VOLUME.

Condenser Motor(s) - (TTA)

- Permanently lubricated totally enclosed or open construction
- Built-in current and thermal overloads
- Ball or sleeve bearing type

Factory installed perforated steel hail guards

- Condenser coil protection from hail, vandals, etc.
- Perforated, painted galvanized steel

Phase Monitor/Reversal Protection

Phase monitor shall provide 100% protection for motors and compressors against problems caused by phase loss, phase imbalance, and phase reversal. Phase monitors are equipped with an LED that provides an ON or FAULT indicator. Quick-Access Panels

- Remove a few screws for access to the standardized internal components and wiring.

Service Valves

- Liquid line service valve (with gauge port)
- Suction line service valve (with gauge port)

Low Ambient (Fan ON/OFF)

- Provides unit cooling operation to outdoor ambient of 0°F
- Low cost solution
- Discharge pressure controls condenser fan operation

Digital Scroll Compressor

A Copeland digital scroll compressor is installed on the lead circuit.

Notes:

1. Hot gas bypass must not be field installed on digital scroll compressor circuit.
2. Digital scroll minimum capacity is based on largest suction riser height. For suction risers up to 15' high, condensing unit turndown is 15%. If riser height is different, please communicate actual height to Trane Creative Solutions.

Modulating Hot Gas Reheat for Dehumidification

The unit is factory equipped with modulating hot gas reheat on the 2nd circuit. By diverting hot discharge gas to a coil in the supply air stream, approximately room neutral air will be delivered to the space.

Field Line Sizes

	Circuit 1	Circuit 2
Suction Riser - insulated	7/8"	1-1/8"
Suction Horizontal - insulated	1-1/8"	1-1/8"
Liquid	1/2"	1/2"
Reheat Supply - insulated	-	5/8"
Reheat Return	-	1/2"

Symbio Dehumidification and Cooling Discharge Air Temperature Control

Factory installed to provide dehumidification and discharge air temperature controls. Cooling mode shall be initiated by a field provided dry contact closure or BAS communication. Dehumidification mode shall be initiated by a field provided dry contact closure or BAS communication.

A duct discharge air temperature and humidity sensor is factory provided for field installation.

UC400 Sequence of Operation

Cooling Mode: Upon being indexed to cooling mode, Symbio shall control compressors to cooling discharge air temperature setpoint. Cooling discharge air temperature setpoint is an analog value that can be adjusted with Tracer TU or through BACnet communication.

Dehumidification Mode: Upon being indexed to dehumidification mode, Symbio shall control compressor capacity

between 50-100% to discharge air dewpoint setpoint. The UC400 shall modulate the refrigerant valve to reheat discharge air temperature setpoint. Temperature setpoints are analog values that can be adjusted with Tracer TU or through BACnet communication. Field controls must set an appropriate AHU airflow during dehumidification to prevent overcooling at the minimum 50% compressor capacity.

Additional Symbio Points	
<u>Analog Inputs</u>	<u>Binary Inputs</u>
Discharge Air Temperature	Enable Cooling Local
Discharge Air Humidity	Enable Dehumidification Local
<u>Analog Outputs</u>	<u>Binary Outputs</u>
Digital Scroll Compressor Control	<u>Binary Values</u>
Reheat Valve	Enable Cooling BAS
<u>Analog Values</u>	Enable Dehumidification BAS
Cooling Discharge Air Temperature Setpoint	
Reheat Discharge Air Temperature Setpoint	
Reheat Discharge Dewpoint Setpoint	
Discharge Air Dewpoint	

Dimensional Drawings - Odyssey Split System Outdoor Unit
 Item: B1 Qty: 1 Tag(s): CU-1

Condenser and Air Handler Pairings

Table 3. Model number descriptions

TWE Air Handler with Symbio
<p>Digit 15 — Controls</p> <p>1 = Constant Volume C = 2 Stage Airflow (Electromechanical Condenser Only) D = 2 Stage Airflow/Single Zone VAV (Symbio Condenser Only)</p>
TWE Air Handler (pre-Symbio)
<p>Digit 15 — Controls</p> <p>0 = Constant Volume A = 2 Stage Airflow (Electromechanical Condenser Only) B = Single Zone VAV (ReliaTel Condenser Only)</p>

Table 4. Condenser and air handler pairing instructions (See document SS-SVN016A-EN)

Condenser (model # digit)	Air Handler		Wiring Reference	Instructions
	Type	Supply Fan Type (model # digit)		
Odyssey Electromechanical (Digit 15 = E)	Odyssey Symbio	Constant Volume (Digit 15 = 1)	"Pairing C or 3," p. 10	Pairing F, D or G require wire harness kit WIR010190 (required) and WIR010185 (optional) to connect Air Handler Relay Board to VFD.
		2-Speed Airflow (Digit 15 = C)		
		Single Zone VAV (Digit 15 = D)	"Pairing D," p. 12	
Odyssey ReliaTel (Digit 15 = R)	Odyssey Symbio	Constant Volume (Digit 15 = 1)	"Pairing 4," p. 14	Pairing F, D or G require wire harness kit WIR010190 (required) and WIR010185 (optional) to connect Air Handler Relay Board to VFD.
		2-Speed Airflow (Digit 15 = C)	"Pairing E," p. 16	
		Single Zone VAV (Digit 15 = D)	"Pairing F," p. 16	

Dimensional Drawings - Odyssey Split System Outdoor Unit
Item: B1 Qty: 1 Tag(s): CU-1

Condenser and Air Handler Pairings

Table 4. Condenser and air handler pairing instructions (continued) (See document SS-SVN016A-EN)

Condenser (model # digit)	Air Handler		Wiring Reference	Instructions	
	Type	Supply Fan Type (model # digit)			
Odyssey Symbio (Digit 15 = S)	Odyssey Symbio	Constant Volume (Digit 15 = 1)	"Pairing A," p. 18	Install a shielded, twisted pair cable if the Air Handler has Electric Heat and/or requires Single Zone VAV operation (Trane IMC communication)	
		2-Speed Airflow (Digit 15 = C)	"Pairing H," p. 20	Pairing G, H, and 2 will not have heat in defrost. Pairing G, H, and 2; electric heat will not operate if zone sensor installed, only with a thermostat Install a shielded, twisted pair cable if the Air Handler has Electric Heat and/or requires Single Zone VAV operation (Trane IMC communication)	
		Single Zone VAV (Digit 15 = D)	"Pairing B," p. 18	Install a shielded, twisted pair cable if the Air Handler has Electric Heat and/or requires Single Zone VAV operation (Trane IMC communication) Install a shielded, twisted pair cable for Symbio Condenser control of the Air Handler supply fan VFD (Modbus communication)	
	Odyssey Electromechanical	Constant Volume (Digit 15 = 0)	"Pairing 1 or 2," p. 22	Pairing G, H, and 2 will not have heat in defrost.	
		2-Speed Airflow (Digit 15 = A)		Pairing G, H, and 2; electric heat will not operate if zone sensor installed, only with a thermostat.	
	Odyssey ReliaTel	Variable Speed, Single Zone VAV (Digit 15 = B)	"Pairing G (preferred)," p. 24	Pairing G, H, and 2 will not have heat in defrost. Pairing G, H, and 2; electric heat will not operate if zone sensor installed, only with a thermostat. Install a shielded, twisted pair cable for Symbio Condenser control of the Air Handler supply fan VFD (Modbus communication)	
			"Pairing G (optional)," p. 27	Pairing G, H, and 2; electric heat will not operate if zone sensor installed, only with a thermostat. Pairing F, D or G require wire harness kit WIR010190 (required) and WIR010185 (optional) to connect Air Handler Relay Board to VFD. This pairing requires the replacement of the RTOM module with a Symbio Relay Board (MOD03105) and that the VFD wires 81B, 82B, 93B, 94B and 94D be replaced with wire harness kit WIR010190 (required) and WIR010185 (optional). The Air Handler will operate as a 2-speed fan.	
	Generic Air Handler	Constant Volume	"Pairing Y," p. 29		
	Two Symbio Condensers (2 condensers to 1 air handler)	Odyssey Electromechanical		"Pairing Z," p. 30	

Dimensional Drawings - Odyssey Split System Outdoor Unit

Item: B1 Qty: 1 Tag(s): CU-1

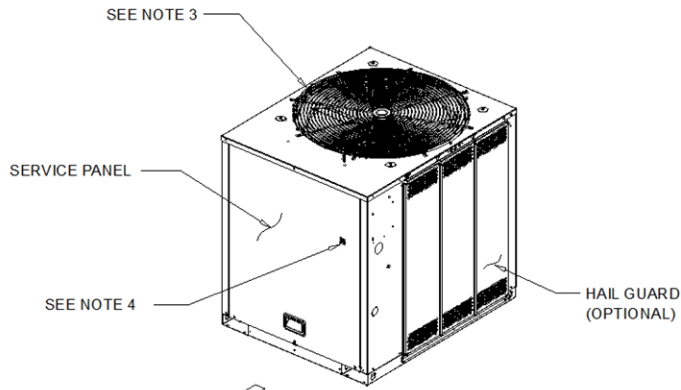

NOTES:

1. ACCESS OPENING IS FOR FIELD INSTALLED BAYLOAM ACCESSORY.
2. MINIMUM CLEARANCE FOR PROPER OPERATION IS 36" FROM WALLS, SHRUBBERY, PRIVACY FENCES ETC. MINIMUM CLEARANCE BETWEEN ADJACENT UNITS IS 72". RECOMMENDED SERVICE CLEARANCE 48"
3. TOP DISCHARGE AREA SHOULD BE UNRESTRICTED FOR 100" MINIMUM. UNIT SHOULD BE PLACED SO ROOF RUN-OFF WATER DOES NOT POUR DIRECTLY ON UNIT
4. OUTDOOR AIR TEMPERATURE SENSOR OPENING (DO NOT BLOCK OPENING).

REFRIGERANT

1. SUCTION CONNECTION 1 1/8"OD) AND LIQUID CONNECTION (1/2" OD)

SERVICE CLEARANCE
48" (SEE NOTE 2
FOR CLEARANCE)

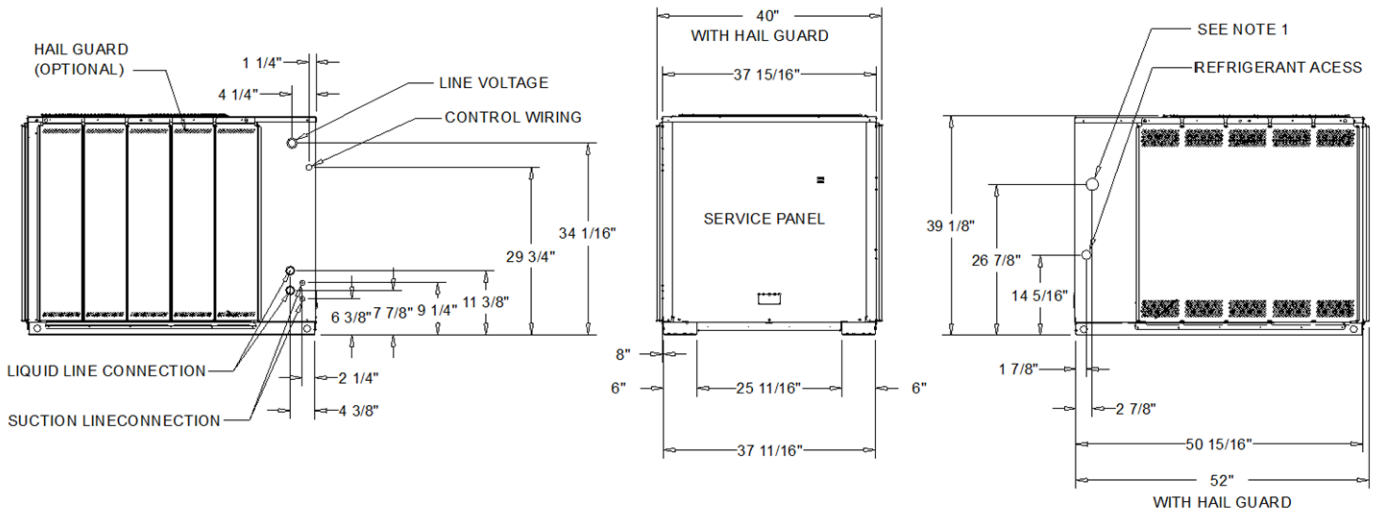

SERVICE PANEL SIDE

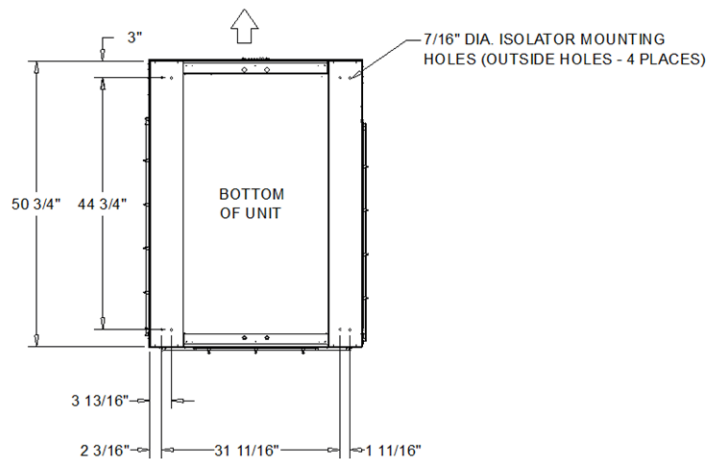

10 TON COOLING CONDENSER (DUAL COMPRESSOR)

DIMENSIONAL DRAWING

Accessory - Odyssey Split System Outdoor Unit
 Item: B1 Qty: 1 Tag(s): CU-1

Temp/Humidity Transducer

Model HU-226

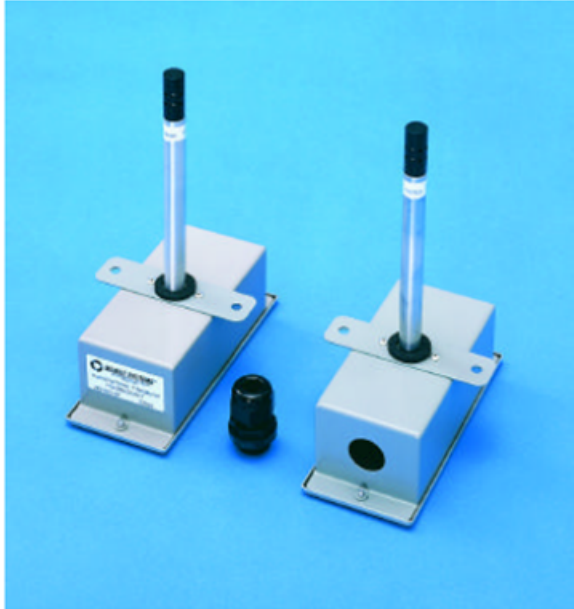

- Ultra-fast response polymer capacitance humidity sensor and precision thermistor or platinum RTD Temperature Sensor
- Not affected by condensation, fog, high humidity or contaminants
- Highly accurate, repeatable, stable output with negligible hysteresis
- Wide 12-40 VDC/12-35 VAC unregulated supply voltage (humidity only)
- Two temperature compensated humidity output versions, 4-20 mA 2-wire or field selectable 0-5 VDC/ 0-10 VDC
- NIST traceable $\pm 2\%$ or $\pm 3\%$ calibration and $\pm 0.2\%^\circ\text{C}$ thermistor interchangeability or $\pm 0.1\%$ RTD accuracy
- Enclosure type NEMA 4 (IP-65) duct mount
- Conforms to EMC standards EN50082-1/ EN55014/EN60730-1

The HU-226 is an extremely fast, stable and accurate Temp/Humidity Transducer designed for harsh environments. The polymer humidity capacitance sensor is not affected by harsh contaminants, condensation, fog or extremely high humidity over a prolonged period of time. If dust or other contaminants accumulate on the sensor, the probe can be washed in industrial grade isopropyl alcohol and put back in service without any calibration shift. Each unit is individually calibrated in an environmental test chamber to meet or exceed NIST traceable $\pm 2\%$ or $\pm 3\%$ accuracies. The HU-226 is temperature compensated for -30°F to $+130^\circ\text{F}$ operation with negligible error. Field selectable outputs, and fully temperature compensated NIST traceable accuracy, non-interacting zero and span adjustments, NEMA 4 (IP-65) steel enclosure with external mounting bracket, short circuit and reverse polarity protected output, and a liberal two year warranty are some of the features which make the HU-226 the industry's highest performance, most reliable Temp/Humidity Transducer.

Weight, Clearance & Rigging - Odyssey Split System Outdoor Unit
Item: B1 Qty: 1 Tag(s): CU-1

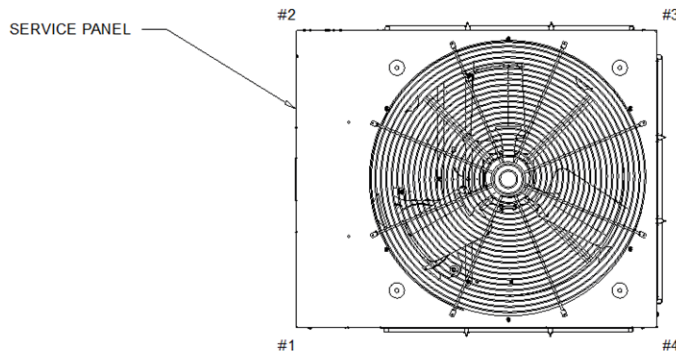
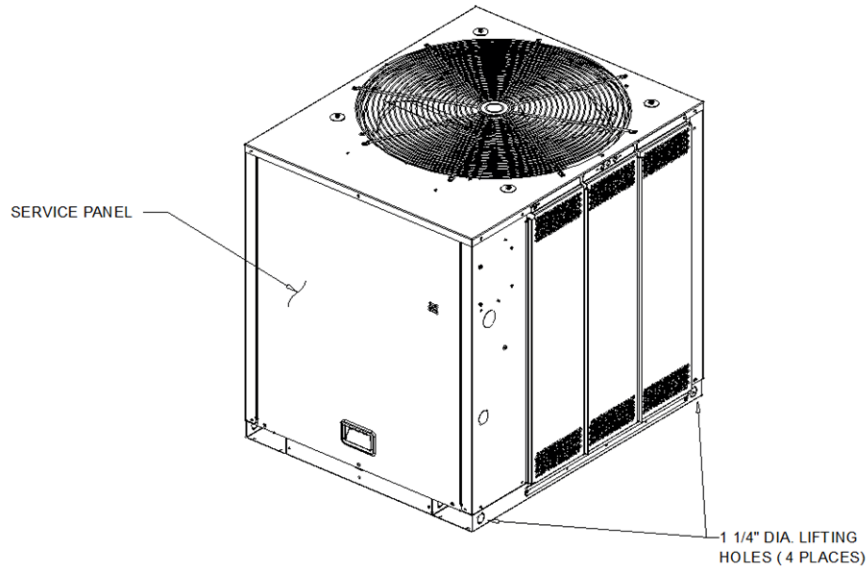

WEIGHTS AND CORNER WEIGHTS

Shipping:	436.0 lb
Net	391.0 lb
Corner 1:	113.0 lb
Corner 2:	112.0 lb
Corner 3:	84.0 lb
Corner 4:	82.0 lb

WEIGHTS AND LOAD POINT LOCATION

WEIGHT AND RIGGING

Field Wiring - Odyssey Split System Outdoor Unit
Item: B1 Qty: 1 Tag(s): CU-1

CSTTB1 -

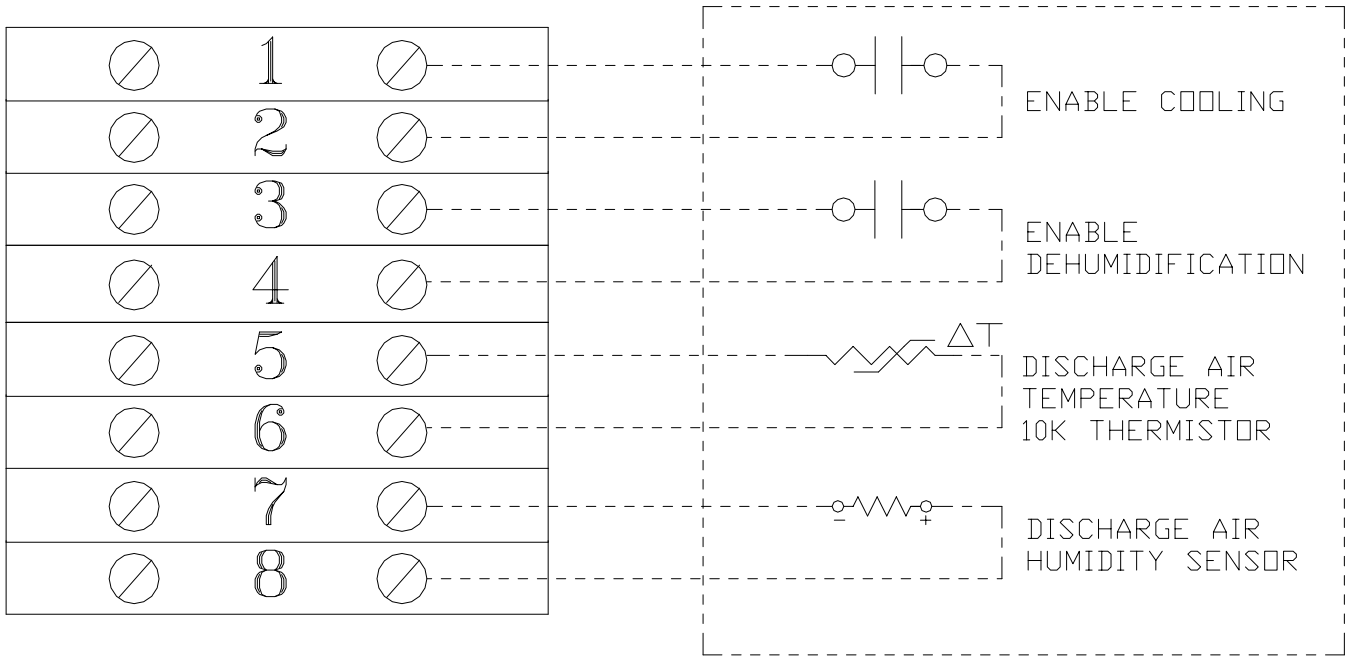

Field Installed Options - Part/Order Number Summary

This is a report to help you locate field installed options that arrive at the jobsite. This report provides part or order numbers for each field installed option, and references it to a specific product tag. It is NOT intended as a bill of material for the job.

Product Family - Performance Climate Changer (UCCA)

Item	Tag(s)	Qty	Description	Model Number
A1	OAHU-1	1	Performance Climate Changer (UCCA)	UCCAG06C0G0F00035015 A0DD878CA0AC00100001

Field Installed Option Description	Part/Ordering Number
Outside air temperature and duct static press sensor, fact-provided, ships loose	

Product Family - Odyssey Split System Outdoor Unit

Item	Tag(s)	Qty	Description	Model Number
B1	CU-1	1	6 - 25 Ton Unitary Split Systems Outdoor	TTA12043DAA**BS010001000000000000 00000000

Field Installed Option Description	Part/Ordering Number
Ext. mount Small cabinets (Symbio)	BAYLOAMS10B
Pressure Transducer for ICM	BAYLOTR001A
Service Valve accessory kit	BAYVALV003A



PoluAl XT

- ✓ *Prevents corrosion*
- ✓ *Special spray technique*
- ✓ *Heat conductive*

Blygold PoluAl XT – HVAC/R coil protection

Blygold has developed pioneering coatings specifically for HVAC corrosion protection. From the very beginning Blygold has always focused on corrosion protection for heat exchangers. Different types of corrosion such as galvanic or pitting rapidly decrease the heat exchange efficiency of coils and the efficiency of the total HVAC equipment.

In the quest for more efficient air-conditioning equipment several innovations have increased the nominal efficiency of heat exchanger coils. With the introduction of enhanced fins, increased fin density, adiabatic systems and micro channels not only the nominal efficiency has increased but also pollution and corrosion vulnerability. High pressure failures, early replacements and increased power consumption can be prevented with the right preventive and corrective measures. Protecting these heat exchangers calls for specialists. The geometry makes the application of coatings complicated and the need for heat transfer excludes standard coating systems.

WITH BLYGOLD POLUAL XT

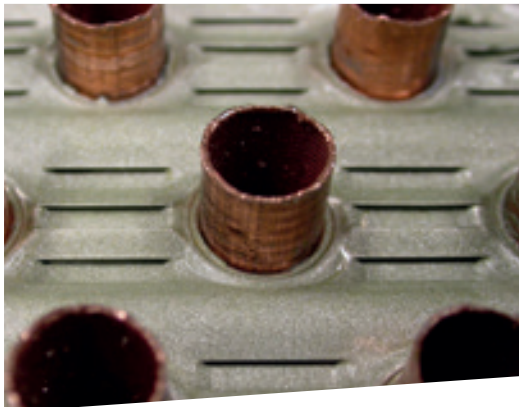

WITHOUT BLYGOLD POLUAL XT



Special product

Our most coveted product is PoluAl XT: an aluminium pigmented polyurethane coating especially developed for the protection of air-cooled heat exchangers. PoluAl XT stands apart from the rest. It has an excellent chemical and UV resistance. It offers flexibility, excellent adhesion with negligible effect on the heat transfer. Plus it can be applied in a very thin layer, to prevent pressure drop. PoluAl XT combines all these properties with extraordinary corrosion protection.

- ✓ Heat conductive
- ✓ 11.000+ hours salt spray test UV resistance
- ✓ UV resistance
- ✓ Ultra thin layer (20 µm) to prevent pressure drop
- ✓ Highly Flexible

The application

A good coating will only perform when applied in a high quality process. Coating heat exchangers requires specialists that are able to apply the coating on every piece of bare metal present in a heat exchanger. Blygold uses proprietary spray techniques that can only be practiced by certified applicators. These qualified applicators are essential to realize a corrosion resistant and maintenance friendly heat exchanger. Blygold coating application is preferably done in a conditioned Blygold workshop but is, under restricted circumstances, also possible on-site.

WITHOUT BLYGOLD POLUAL XT



WITH BLYGOLD POLUAL XT



TECHNICAL INFORMATION

Treatment:	PoluAl XT
Coating type:	Aluminum pigmented Polyurethane
Color:	Champagne
Pretreatment:	Degreasing
Temperature Range (dry):	-20° to 150 °C (-4° to 302 °F)
Substrates:	Aluminum and Copper
ASTM B117:	11,000+ hours
ASTM B-287:	4,000+ hours
Kesternich (2.0 ltr SO₂):	80 cycles
Layer Thickness:	25 -30 µm (1 mil)
Pressure Drop:	0-5%
Thermal Resistance:	0-3%
Application:	Qualified Blygold Applicator
UV Resistance:	Excellent
Adhesion (cross hatch):	0 (European) 5b (USA)
Applications:	Heat exchanging surfaces in high temperatures
Chemical Resistance:	Excellent

*A good product
is just half the job,
the application
is just as
important!*

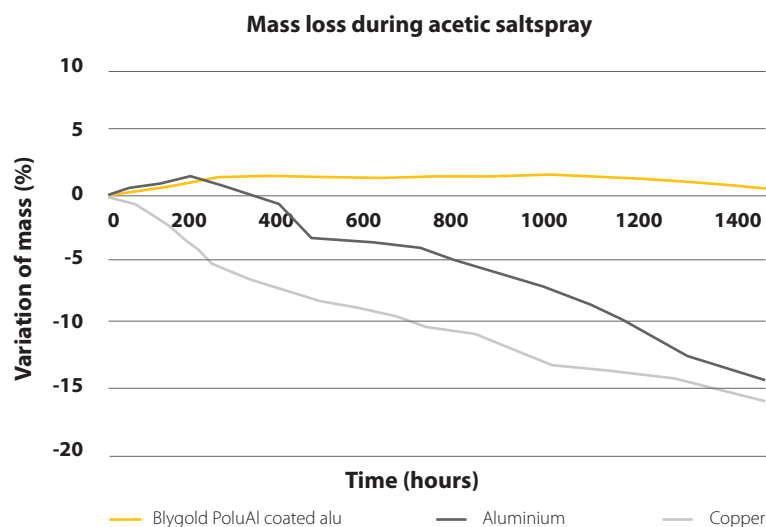



BLYGOLD INTERNATIONAL

Blygold is an innovative and forward-thinking company offering unique and sustainable high-quality protection against corrosion. With over 40 years experience, we have the know-how and state-of-the-art products and techniques to solve any corrosion problem. Our multitude of success stories says it all.

Application protocols

Because of the specific geometry of heat exchangers, the quality of the application process is just as important as the applied product. Blygold has developed specific application protocols for heat exchangers of all different dimensions, geometries and materials.

Global network

To ensure our products are applied according to these protocols, Blygold works with trained and certified applicators only. Our global network of qualified Blygold applicators can offer local support in over 60 countries around the world.



Quality

- ✓ Over 40 years of experience
- ✓ Unique application techniques
- ✓ Unrivalled test results
- ✓ All trained & qualified applicators
- ✓ ISO 9001 Certified



Innovation

- ✓ Revolutionary R&D
- ✓ Inhouse laboratory
- ✓ Deep understanding of the market
- ✓ Global awareness of customer needs
- ✓ Problem solving mentality



Sustainability

- ✓ Lifetime extension
- ✓ Energy saving & Eco Friendly
- ✓ Life Cycle Cost reduction
- ✓ Maintenance friendly
- ✓ Corporate Social Responsibility

Blygold[®]
CORROSION PROTECTION

P.O. box 44 3990 DA Houten
The Netherlands
www.blygold.com

T. +31 30 634 43 44
E. info@blygold.com

Your local Blygold applicator